



EC-Gold Dual Gas Concentration Transmitter User Manual

Technical Support
Continental North America Toll Free 1-(800) 387-9487
Ph: +1 (905) 829-2418 Fx: +1 (905) 829-4701



A Product of Arjay Engineering Ltd.
Oakville, Ontario, Canada

www.ArjayEng.com
www.EnmetGasDetection.com

TABLE OF CONTENTS

1.0	INSTRUMENT OVERVIEW	3
1.1	Features	3
1.2	Description	3
1.3	Specifications	6
2.0	INSTALLATION.....	7
2.1	Mechanical Installation	7
2.2	Electrical Installation.....	8
3.0	STARTUP AND CONFIGURATION.....	11
3.1	Notes On The User Interface	11
3.2	Startup.....	12
3.3	Menu Configuration	12
3.3.1	Normal Operating Menu Flow Chart.....	13
3.3.2	Sensors Setup Menu Flow Chart	14
4.0	CALIBRATION	15
4.1	Calibration Notes.....	15
4.2	Calibration Procedures (Full Feature Mode)	15
4.3	Calibration Procedures (Standard Feature Mode).....	18
4.3.1	CALIBRATION NOTES	18
4.3.2	SINGLE POINT CALIBRATION	18
5.0	PUSH TO TEST FEATURE	19
6.0	TROUBLESHOOTING	20
7.0	CONTROLLER SETTINGS SHEET.....	21

1.0 INSTRUMENT OVERVIEW

1.1 Features

- Gas monitor for a large variety of gas types.
- Can monitor up to 4 different sensor inputs at one time
 - Port 1: on board CO (Carbon Monoxide) Electrochemical
 - Port 2: on board electrochemical for NO₂ (Nitrogen Dioxide), CL₂ (Chlorine), H₂S (Hydrogen Sulfide), NH₃ (Ammonia) and others.
 - Port 3: integral or remote MOS broad range toxic and combustibles
 - Port 4: remote 4-20 mA input transmitters
- Carbon Monoxide sensor has expected life of **5 years min. (3 year guarantee)**
- Other sensors have expected life of 2 years (1 year guarantee)
- Output may be user selectable for analog (4-20mA / 2-10V) or Arjay's Discrete Voltage Output (DVO).
- Convenient pushbutton calibration.
- User selectable for Single or Dual Point calibration
- High/High, High, Low, and optional System Fault Indication in place of High/High alarm
- User selectable High and Low Alarm levels
- Modbus protocol via RS-485 for access by Arjay/Enmet Central Access Panel or compatible system
- Can be used as a stand alone gas detector or can be used with other EC-Gold sensors for interfacing with an Arjay Central control panel or customer system
- User specified custom features might be added by contacting Arjay Engineering Ltd.

1.2 Description

The EC-Gold Dual can be used a Stand Alone gas detector with relays and outputs available to communicate with remote devices such as alarms, fans and building automation systems.

The standard model provides 3 relays, a 4-20 mA output and an RS-485 interface. The full feature model provides the addition of an LCD display of concentration, buzzer with silence, and keypad interface.

The 4-20 mA output will represent the peak value determined from all sensor inputs based on the percentage concentration of their range. For example, assume the detector has a CO sensor calibrated for 0-200 ppm and an NO₂ sensor with a calibrated range of 0-20 ppm. If the CO sensor reads a 20ppm and the NO₂ sensor reads 10ppm, the 4-20 mA output will be 12 mA. This will represent that the NO₂ is at 50% of its range while the CO is only at 10% of its range. An analog output cannot be averaged among sensors. This would provide outputs not representative of actual conditions and could result in unsafe conditions.

The relays are common to all sensors and are set to ppm or % LEL values specific and proper for each sensor type.

The LCD display will provide a real time reading of the ppm or % LEL concentrations of all sensors.

The EC-Gold Dual can be used with multiple sensors connected to any Arjay/Enmet Control panel. The following are examples of typical methods of installing the EC-Gold Dual.

Figure 1.0: The EC-Gold Dual can be a Stand Alone detector to interface with fans or alarms using the relays or analog outputs.

Figure 1.1: EC-Gold Dual can be combined with other EC-Gold Dual or EC-Gold sensors to the ISA 66 RLU panel using the cost effective Arjay/Enmet DVO signal. Ideal for multi-zone installations where a central control panel is desirable.

Figure 1.2: EC-Gold Dual can be combined with other EC-Gold Dual or EC-Gold sensors to the ISA Gas Alert Max panel using the cost effective Arjay/Enment DVO signal. Ideal for single or multi-zone installations where the control panel is desirable at each fan location or in central location.

Figure 1.3: EC-Gold Dual can be combined with other EC-Gold Dual or EC-Gold sensors to the PG-2000 panel using the RS-485 communication to address each sensor. Ideal for applications that require more complex zone control or analog outputs for VFD fan control.

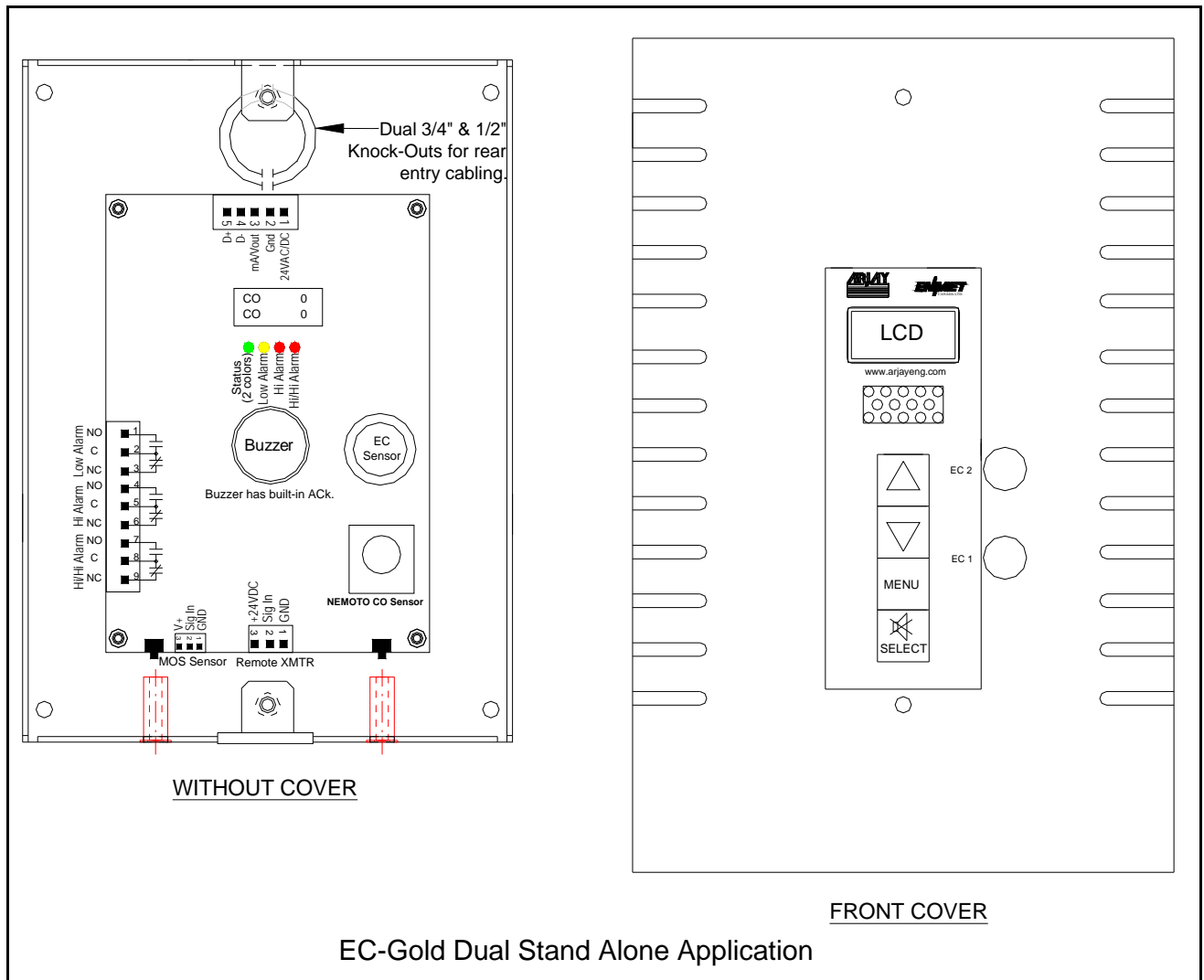

Figure 1.0

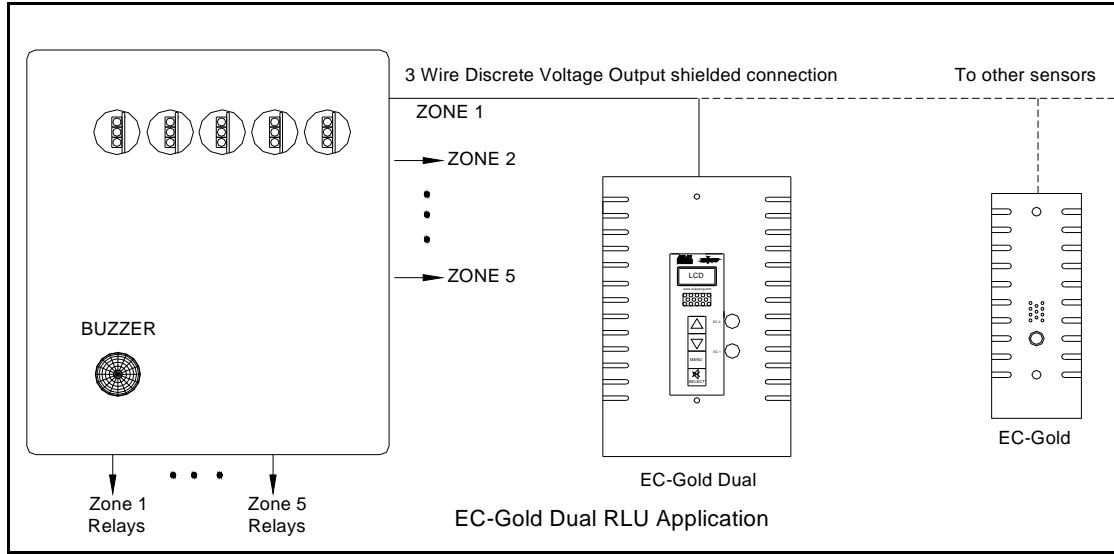

Figure 1.1

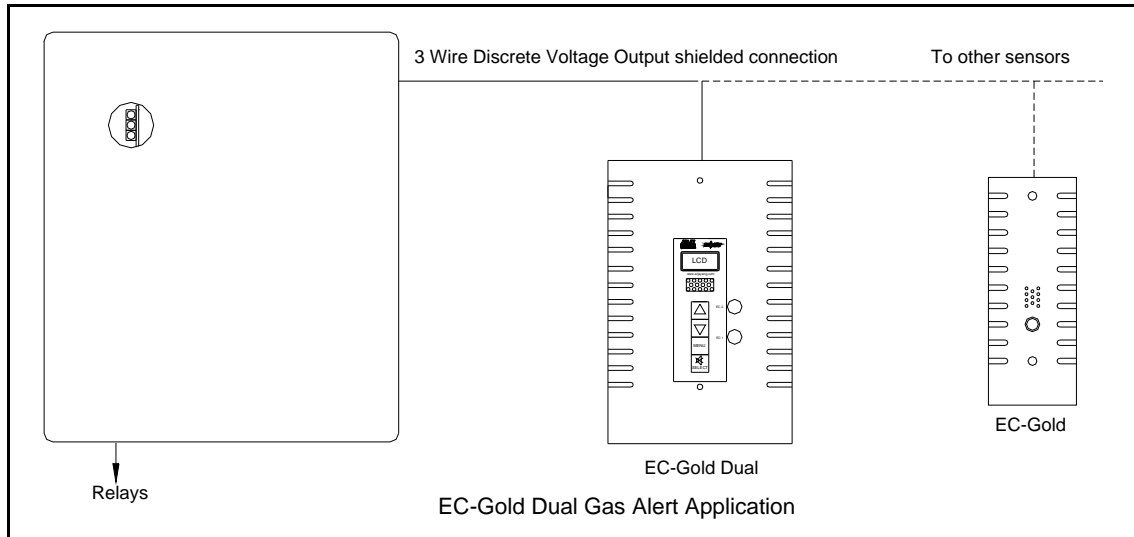

Figure 1.2

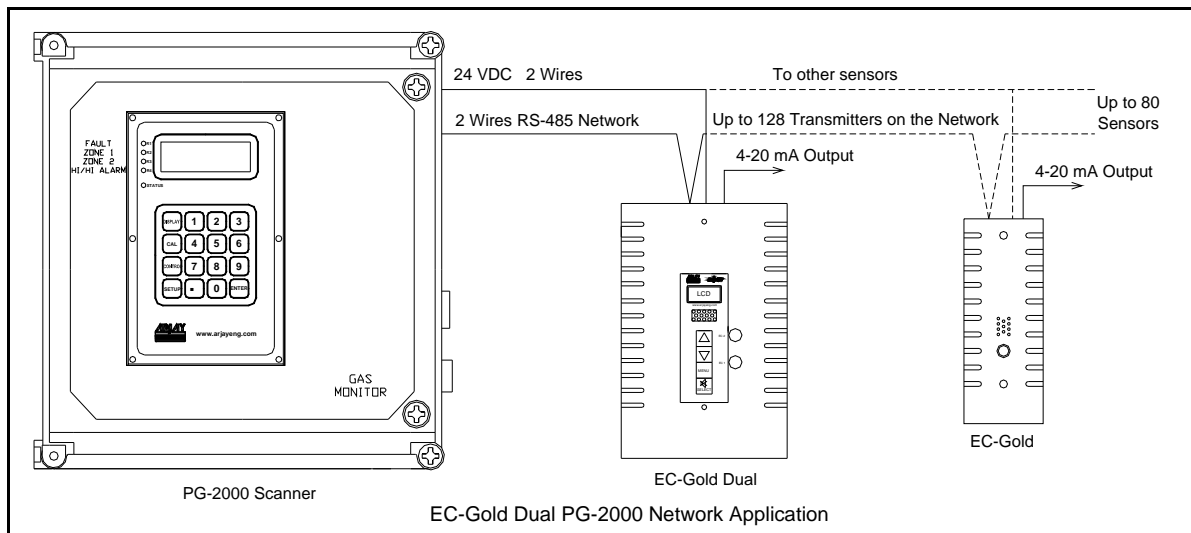

Figure 1.3

1.3 Specifications

OPERATION

The EC-Gold Dual is a multi-sensor gas detector. A variety of gases may be sensed when fitted with the appropriate sensors.

PUSH-TEST FEATURE

On demand using the Push to Test pushbutton.

LCD DISPLAY/KEYPAD

2 x 8 LCD display showing ppm concentrations and calibration menus

USER INTERFACE

Calibration and setup	Keypad, LCD, pushbutton, and LED status lights.
Push-Test	Pushbutton.
Network	RS-485 modbus protocol. Used either with the ARJAY/ENMET CAP unit or via third party, modbus compatible systems.

INPUTS

Port 1 (EC1):	on board CO (Carbon Monoxide) Electrochemical
Port 2 (EC2):	on board electrochemical for NO ₂ (Nitrogen Dioxide), CL ₂ (Chlorine), H ₂ S (Hydrogen Sulfide), NH ₃ (Ammonia) and others.
Port 3:	integral or remote MOS broad range toxic/combustibles and catalytic combustibles
Port 4:	remote 4-20 mA input transmitters

OUTPUTS

mA output	When configured for Analog output: 4-20mA into 700 ohms max.
DC Voltage output	When configured for Voltage output: 2-10V proportional to calibrated range.
mA / Voltage output	0.1% resolution – non-isolated.
RLU DV output	When configured for RLU Discrete Voltage Output mode: 0V = No Alarm, 1.8V = Low Alarm, 2.8V = High Alarm, 10V = Sensor Fault. (Sensor Fault only detected with CO sensor).
Alarms	3 alarms (High/High, High, Low) and Optional System Fault May be factory selected
Alarm Indication	High (Red), Low (Yellow), and a 2 color LED for Sensor Fault (Red) and No Alarms (Green). The 2 color LED is also used to flash calibration errors (Red for ~2 seconds after an unsuccessful calibration).

PERFORMANCE

Accuracy $\pm 2\%$ of Full Scale Range (the accuracy is limited by the sensors – the electronic accuracy is better than 1%.

POWER

12VDC - 24VDC @ 200mA max OR 24VAC INPUT (See JP1 Jumper in Fig 2.1)
Require extra current if use external transmitter

MECHANICAL SPECIFICATIONS

Enclosure	Nema 1 wall mount
Dimensions	9.61" [244mm] H x 6.25" [159mm] W x 2" [50mm] D
Weight	0.3 kg

ENVIRONMENTAL SPECIFICATIONS

Operating Temp.	-20°C to +55°C
Relative Humidity	90% max. with no condensation.

2.0 INSTALLATION

2.1 Mechanical Installation

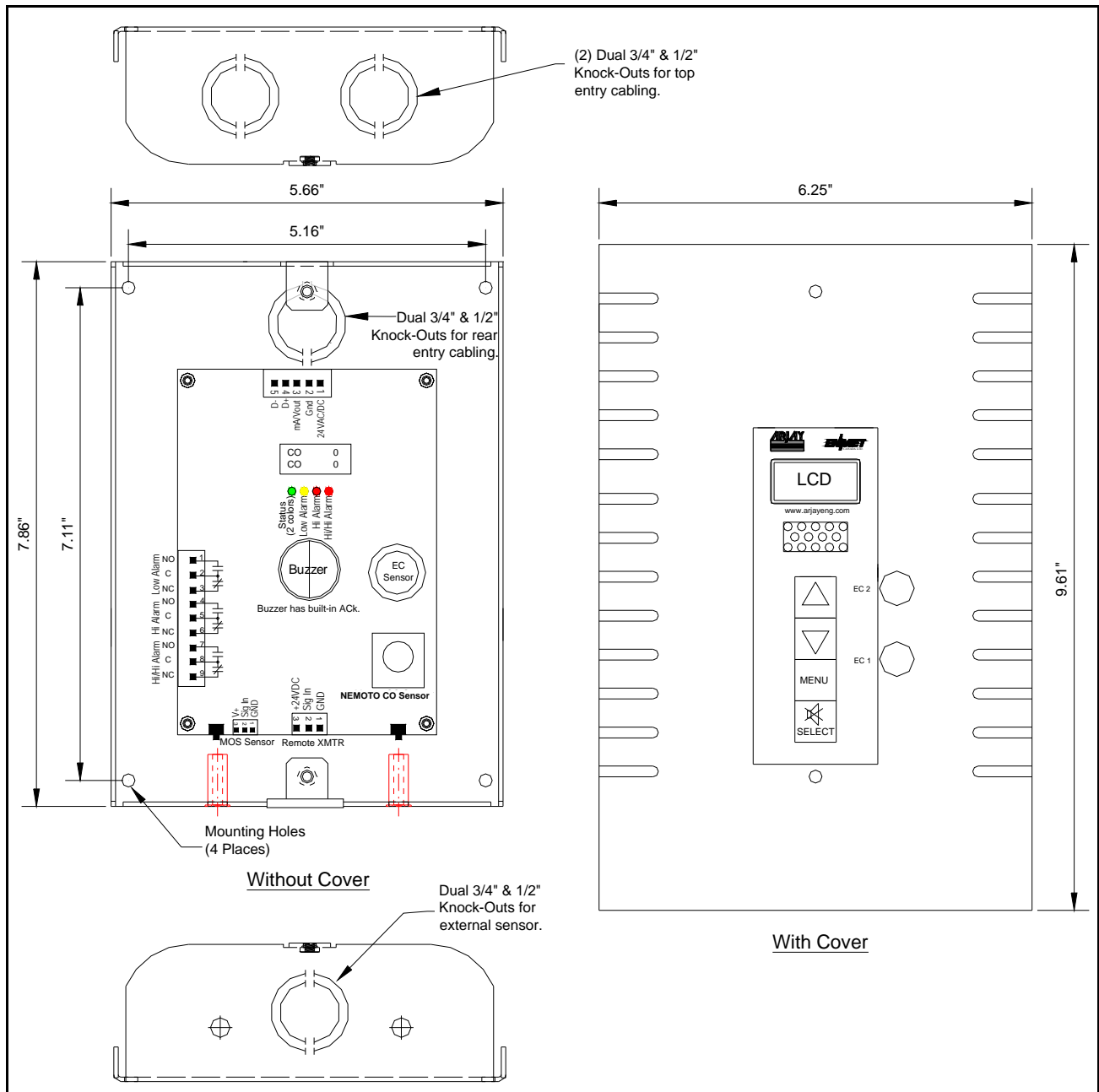

Figure 2.0

Locate the EC-Gold Dual on a vertical surface away from drafts, open doors or windows, condensation or dripping moisture.

The vertical placement (above the floor) depends on the gas being monitored. For CO, the unit should be located within the breathing zone: about 4 - 5 feet above the finished floor*. For other gases, refer to an Arjay Engineering representative.

* Check local building codes (i.e. Ontario Building code requires mounting 2'11" to 3'11").

2.2 Electrical Installation

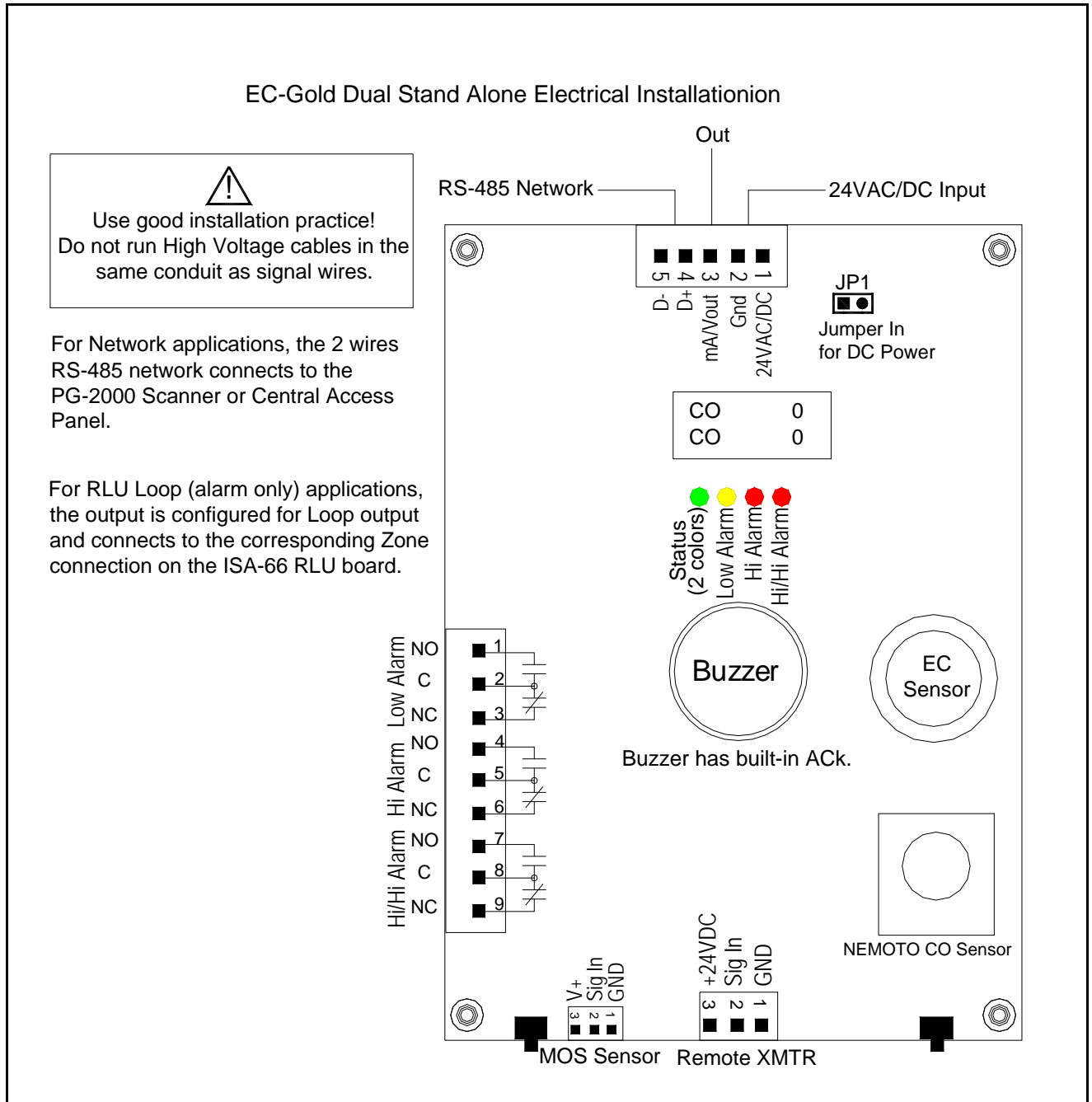

Figure 2.1

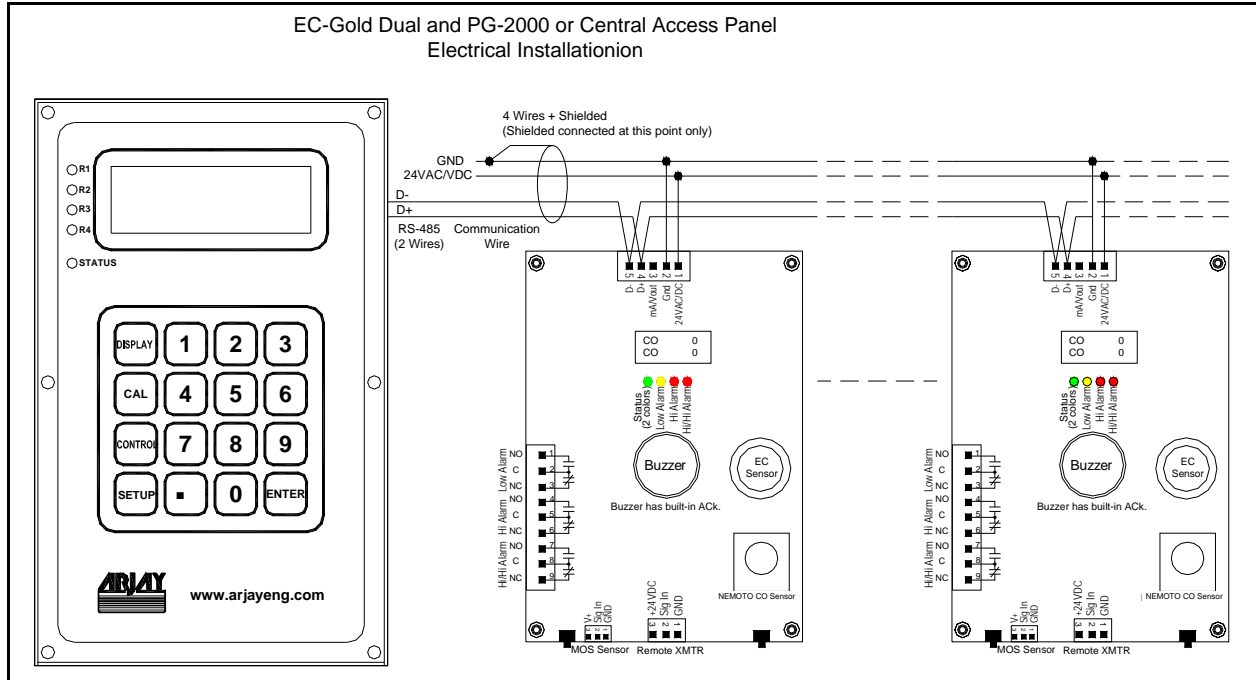

Figure 2.2

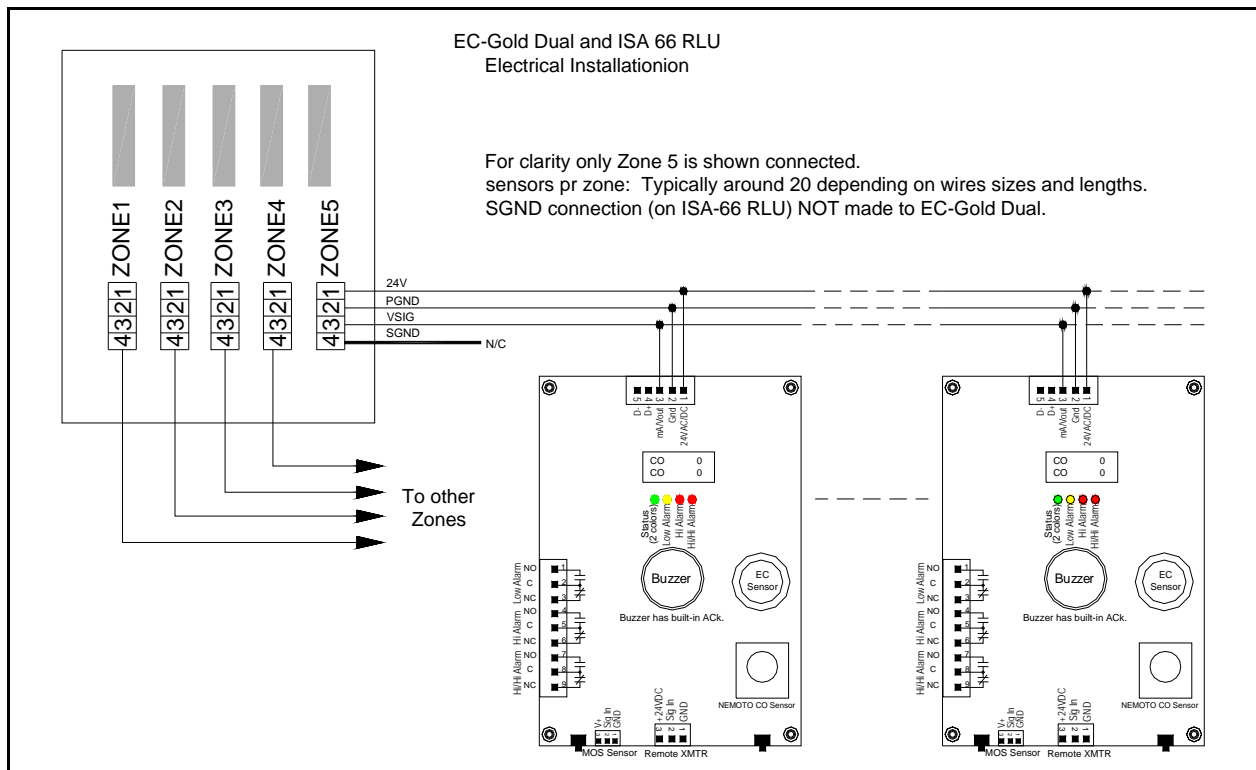

Figure 2.3

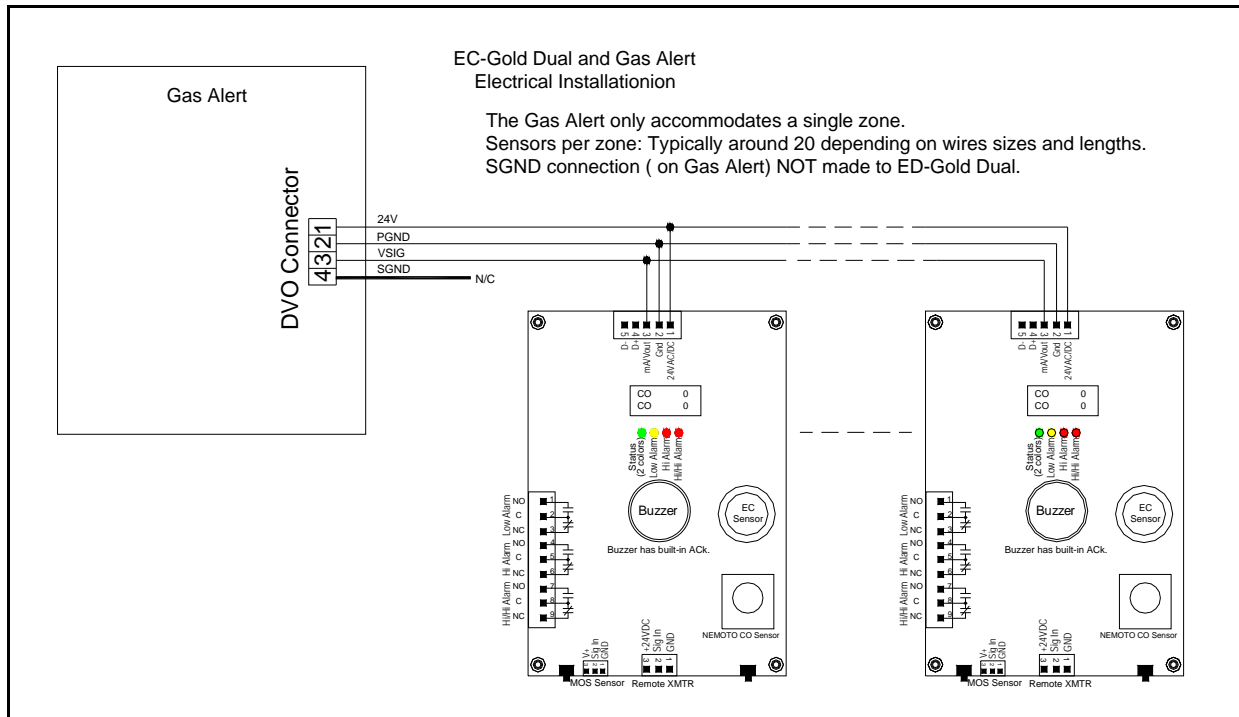

Figure 2.4

All user connections are via mating plug/receptacle connectors to make installation and service easier.

CAUTION:

THE UNIT HOUSES SENSITIVE ELECTRONIC COMPONENTS AND SHOULD BE HANDLED WITH CARE. IF PUNCHING OR DRILLING THROUGH THE ENCLOSURE WALLS IS NECESSARY MAKE SURE THAT THE INTERNAL ELECTRONIC MODULES ARE SHIELDED FROM DEBRIS ESPECIALLY METAL PARTICLES.

PLEASE MAKE SURE THAT THE CONNECTIONS HAVE THE POLARITY AS INDICATED OR THE CONTROLLER MAY BE DAMAGED.

USE GOOD INSTALLATION PRACTICE! DO NOT RUN HIGH VOLTAGE CABLE IN THE SAME CONDUIT AS SIGNAL WIRES.

3.0 STARTUP AND CONFIGURATION

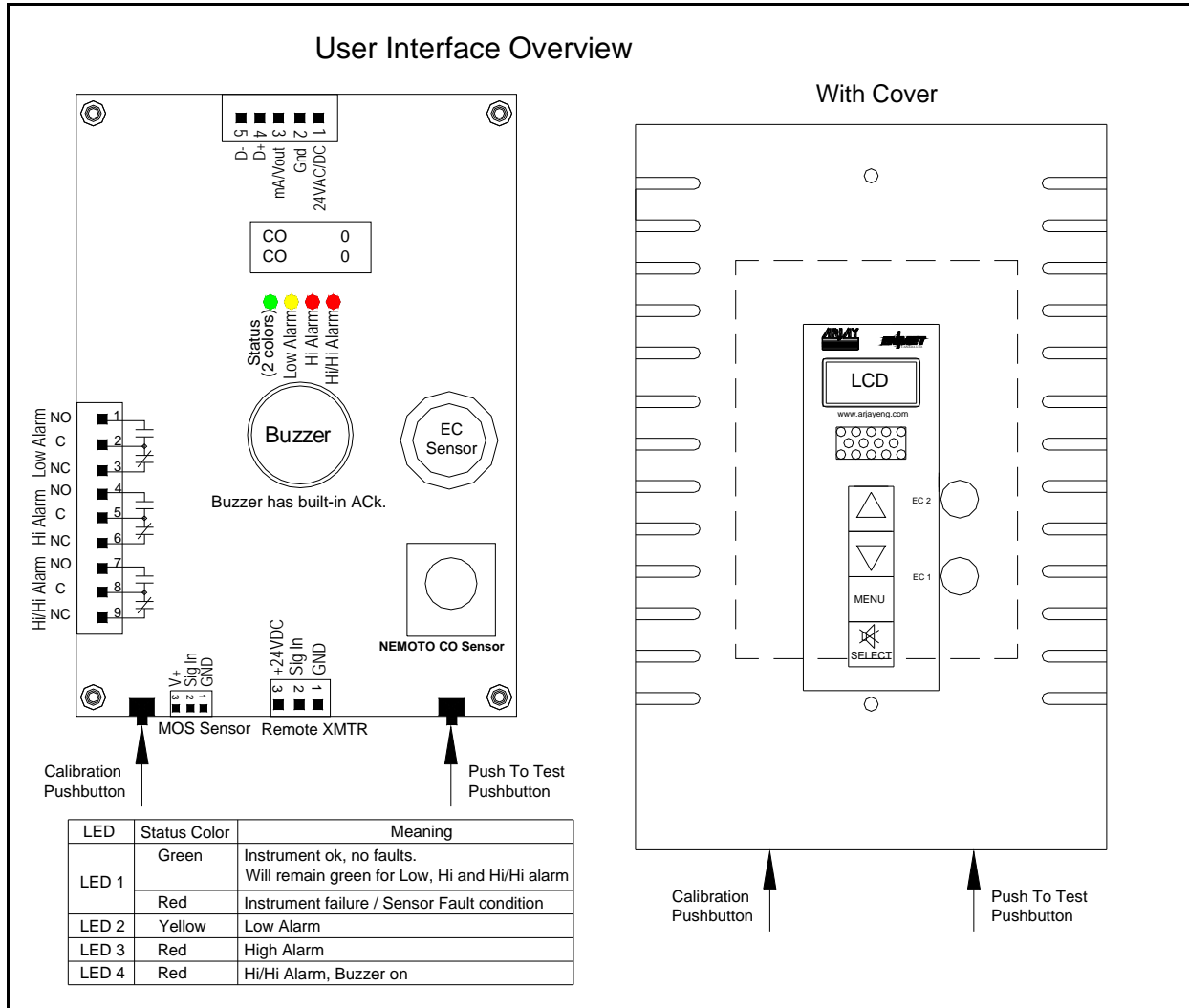

Figure 3.0

3.1 Notes On The User Interface

The EC-Gold Dual can monitor up to 4 different Sensor inputs at one time.

- Port 1: on board CO (carbon monoxide) sensor
- Port 2: on board electrochemical sensor
- Port 3: remote MOS sensor
- Port 4: remote 4-20 mA Input Transmitter

The standard model provides 3 relays, a 4-20mA output and an RS-485 interface. The full feature model provides the addition of an LCD display of concentration, buzzer with silence and keypad interface.

The EC-Gold Dual may be configured and calibrated using the following methods:

1. Using the calibration pushbuttons (basic model without keypad). The pushbutton is accessible without removing the front cover.

2. Using the keypad and display (full feature model). The user follows the menus on the display.
3. Using Arjay's optional 2000-CAL hand held calibrator. The calibrator communicates with the EC-Gold Dual via the RS-485 connection using the modbus protocol. The calibrator's LCD and keypad offer a more convenient method of setting up and calibrating the EC-Gold Dual unit.

3.2 Startup

Power up the unit. The status LED should be green. The High and Low alarm LED's should go off in less than a minute.

The unit is normally pre-configured and calibrated at the factory so field setup is not required on startup.

To re-calibrate, see section 4.0 Calibration.

To re-enter or modify settings, follow the procedures described below. Only the full feature model interface procedure is described here.

3.3 Menu Configuration

After powering up the unit and under normal operating conditions, the LCD displays the Normal Operating Menu. See the next page for detail Menu configuration>

The Default Password: 2000

Alrm Del – Alarm and Buzzer Delay (Setup Alarm Delay On and Off Time in second; setup Buzzer Delay On time in second)

K1 – Relay 1 Alarm Delay On/Off time

K2 – Relay 2 Alarm Delay On/Off time

K3 – Relay 3 Alarm Delay On/Off time

Buzzer – Delay On time

Sel Snsr – Select Sensor

A1 – Relay 1 Alarm Setting Value (normally, Low alarm value)

A2 – Relay 2 Alarm Setting Value (normally, High alarm value)

A3 – Relay 3 Alarm Setting Value (normally, Hi/Hi alarm value)

3.3.1 Normal Operating Menu Flow Chart

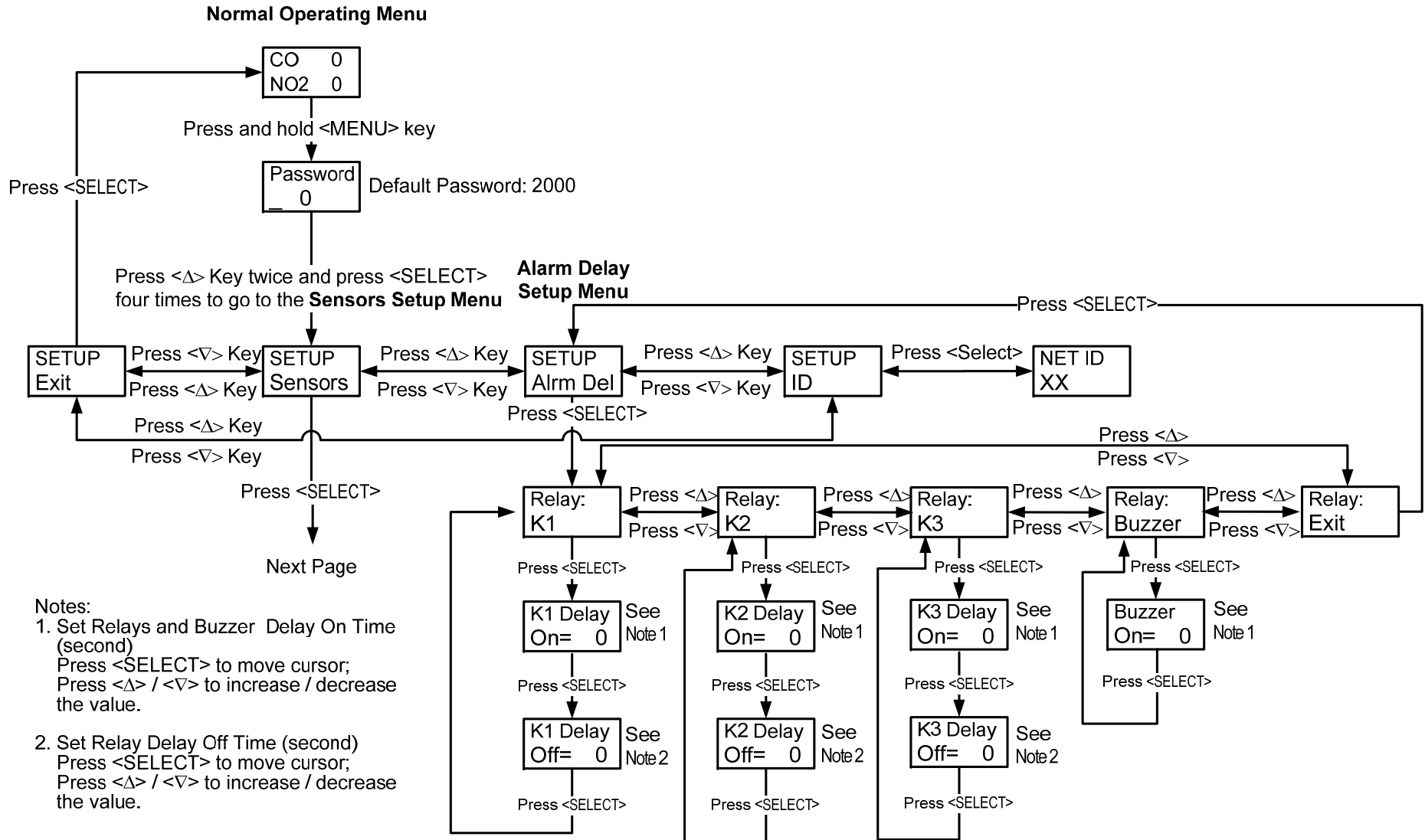

3.3.2 Sensors Setup Menu Flow Chart

Sensors Setup Menu

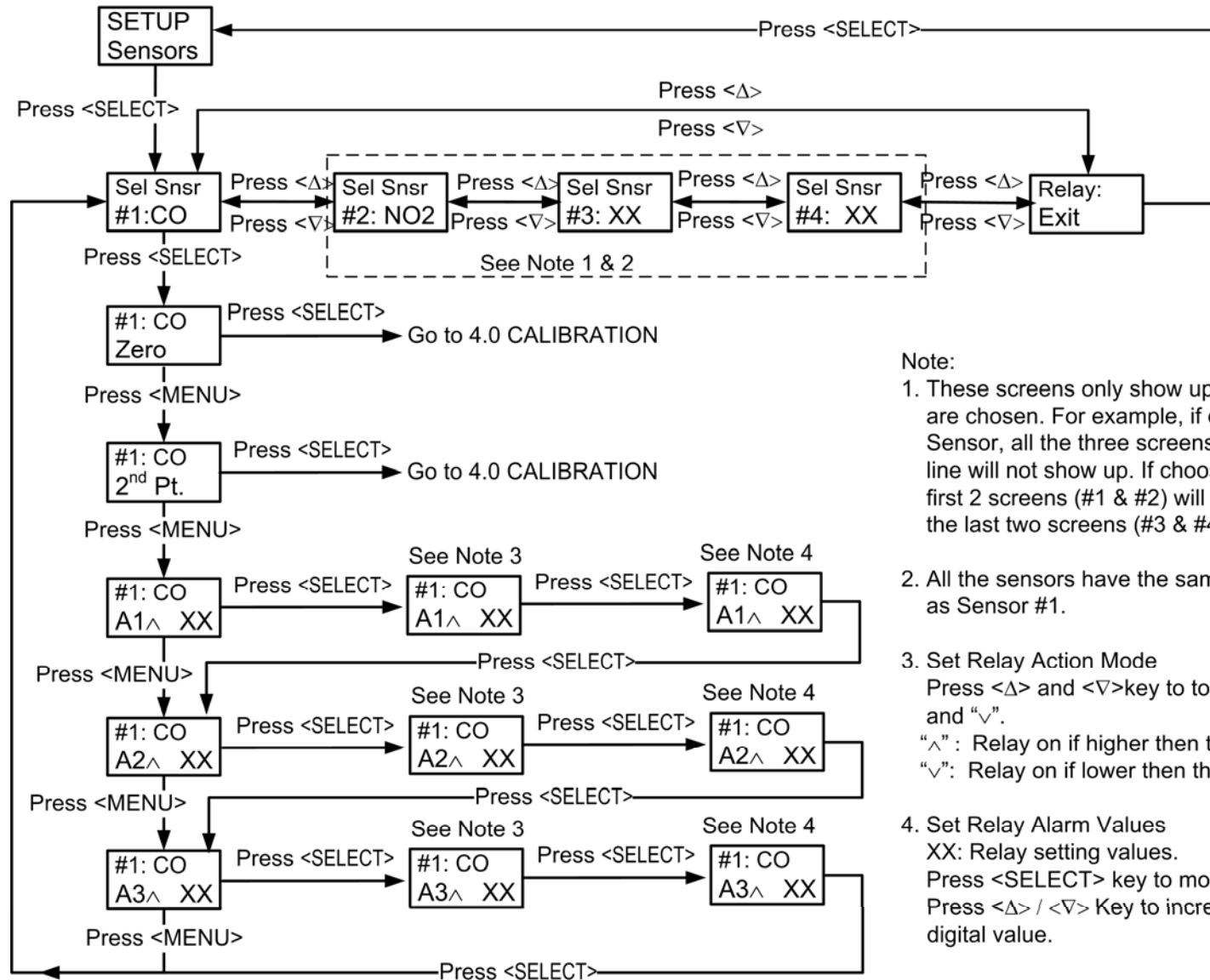

Note:

1. These screens only show up when sensors are chosen. For example, if only choose one Sensor, all the three screens inside the dot line will not show up. If choose 2 sensors, the first 2 screens (#1 & #2) will show up and the the last two screens (#3 & #4) will not show up.
2. All the sensors have the same menu flow chart as Sensor #1.
3. Set Relay Action Mode
Press <Δ> and <∇>key to toggle between “^” and “∇”.
“^” : Relay on if higher then the setting value.
“∇”: Relay on if lower then the setting value.
4. Set Relay Alarm Values
XX: Relay setting values.
Press <SELECT> key to move the cursor.
Press <Δ> / <∇> Key to increase / decrease the digital value.

4.0 CALIBRATION

4.1 Calibration Notes

The instrument was calibrated and tested prior to leaving the factory. Therefore, it is possible to use the instrument directly out of the box. Under normal conditions, recalibration is recommended once every 6 months. For a two point calibration, the first point is typically Zero (clear air); the second point (also called span) is a determined gas concentration value.

If the preset EC-Gold Dual calibration span value is known and you have the same calibration gas concentration, the entire calibration procedure can be completed without removing the front cover.

4.2 Calibration Procedures (Full Feature Mode with LCD / KEYPAD)

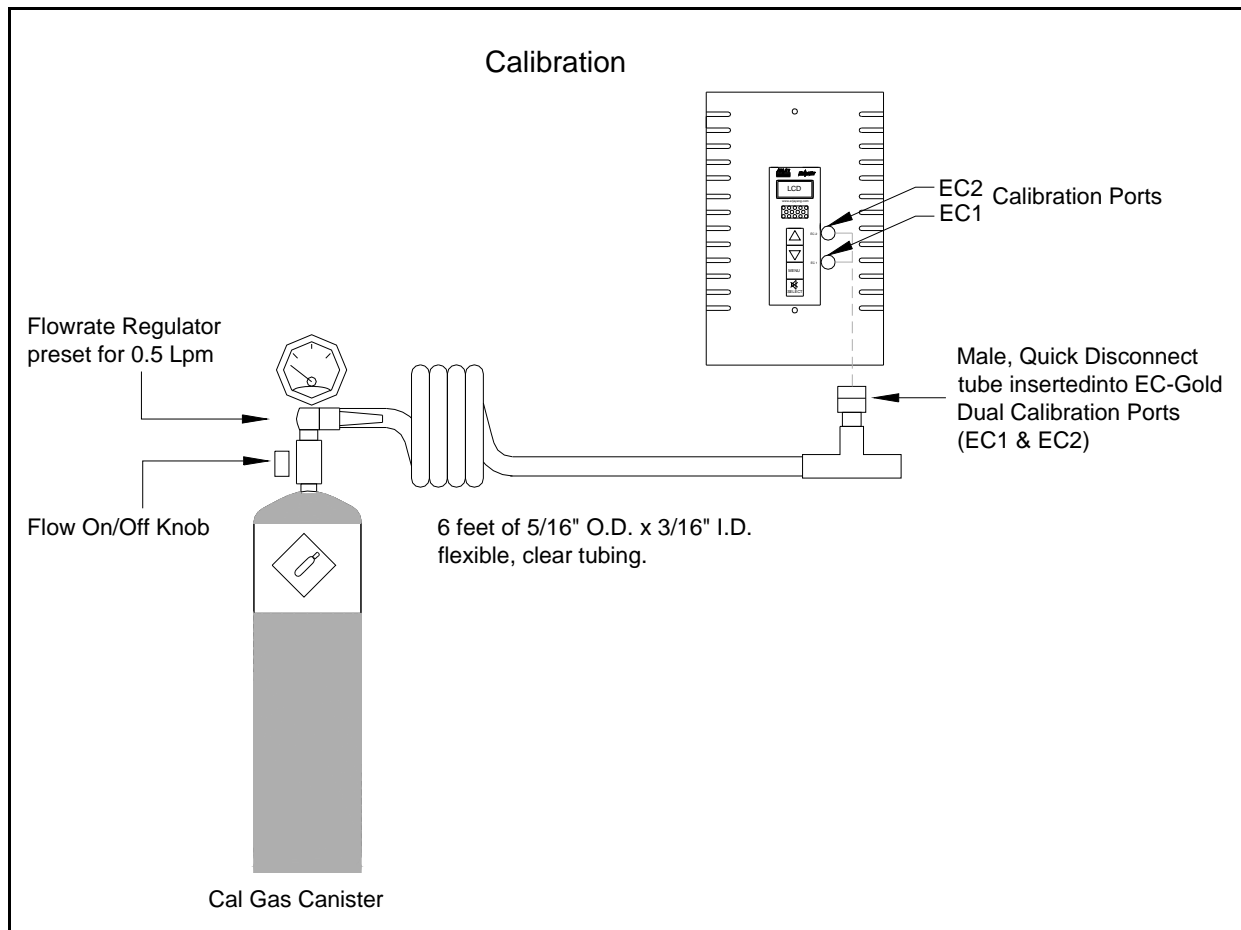

Figure 4.0

- Under normal operating conditions, the LCD displays the following (depending on sensors order):

CO	0
NO2	0

- Follow the Manu Flow Chart, until the following screen display:

#1: CO
Zero

3. Zero Calibration only needs to be done when installing a new sensor. Press <MENU> key to bypass Zero Calibration, and go to step 6 to start second point calibration. If a Zero Calibration is required, follow the steps 4-5.

4. Press <SELECT> key, the LCD display:

Z	xx
mv	xx

5. Make sure the ambient air around the sensor is clean ie. it has no traces of the gas being monitored. In applications where the ambient air is not guaranteed to be clean, use a compressed air calibration canister and apply the air to the sensor hole (EC1). For the Zero point, the mv values should be less then 100 mv. If the mv value is changing within 5 mv for a minimum of 10 seconds, the instrument will automatically accept the Zero calibration. Or press <SELECT> key and finish the first point (Zero) calibration.

6. The LCD now displays the following and the instrument is ready for the second point calibration.

#1: CO
2nd Pt.

7. Press <SELECT> key to start the second point calibration, and the LCD displays the following. Press <SELECT> key to move the cursor and accept the second point calibration. If want to change gas concentration value, press <SELECT> key to move the cursor to proper position and press <MENU> key to increase up to the right value. Press <SELECT> key to accept the gas concentration value.

#1: CO	
S	200

S stands for second point

8. After selecting gas concentration value, the LCD displays the following and the instrument is ready for the second calibration:

S	xxx
mv	xxx

9. Apply the Gas in the sensor hole (EC1). EC1 is for Carbon Monoxide; EC2 is for other types of gas, such as NO2. Start gassing the sensor by opening the valve on the canister. The flow rate is set to 0.5 Lpm (or ~1 SCFH (Standard Cubic Foot per Hour). Wait about 90 seconds. After this, if the mv value is changing within 5 mv for a minimum of 10 seconds, the instrument will automatically accept the second point. Or press <SELECT> key to manually accept the second point. If the calibration was successful, the LCD displays the following. Otherwise, the LCD displays the calibration error message.

#1: CO
Cal OK

10. The "Cal OK" or "Error Message" only displays a couple of seconds, then the LCD displays the following alarm 1 setting value:

#1: CO
A1 ^ 35

11. Press <MENU> key to bypass the Alarm value setting menu, until the following Sensor Selection Menu shows up:

Sel Snsr
#1: CO

12. Press <Δ> or <∇> key to select the #2 Sensor or Exit. If choose the #2 Sensor, the LCD displays the following:

Sel Snsr
#2: NO2

13. Press <SELECT> Key to the second sensor calibration menu. If the sensor is mA input sensor, then go to step 14

#2 NO2
Zero

The calibration procedure for second sensor is the same as the first sensor except for applying gas to sensor hole (EC2). Follow the steps 3-12, then press <MENU> key to go to the normal working display.

14. If the sensor is mA input sensor, the calibration of the sensor is done at the remote sensor (see Remote Sensor Manual). The mA scale is normally factory set, but may be changed if change needed. Press <SELECT> to change mA settings or press <MENU> key to bypass the calibration and go back to the Sensor Selection Menu.

#2 CO
mA Scale

15. Press <SELECT> key to set 4 mA, and the LCD displays the following. Press <SELECT> key to move the cursor and accept the value. Normally, set 4 mA equals 0 ppm. To change the value, press <SELECT> key to move the cursor to proper position and press <MENU> key to increase up to the right value. Press <SELECT> key to accept the setting value.

#2 CO
4= 0

16. Press <SELECT> key to set 20 mA, and the LCD displays the following. Press <SELECT> key to move the cursor and accept the value. 20 mA is normally set for maximum range of remote XMTR. To change the value, press <SELECT> key to move the cursor to proper position and press <MENU> key to increase up to the right value. Press <SELECT> key to accept the setting value.

#2 CO
20= 200

17. Then the display goes to the Alarm setting Menu. Press <MENU> key to bypass the calibration and go back to the Sensor Selection Menu. Repeat Step 12 to Step 16 if calibrate more sensors.
18. Go back to the normal operating Menu by following the Normal Operating Menu Flow Chart

**THIS COMPLETES THE CALIBRATION PROCEDURE FOR
FULL FEATURE CONTROLLER**

4.3 Calibration Procedures (Standard Feature Mode Without LCD / KEYPAD)

4.3.1 CALIBRATION NOTES

The EC-Gold Dual may be calibrated using a **Single Point** calibration procedure, by using calibration push button.

The **Calibration** pushbutton may be accessed using a screwdriver or other fine tool – See **Figure 4.1** for the location of the access hole.

A full Dual Point calibration is always performed at the factory and involves zeroing the sensor in clean air, then calibrating at a preset gas concentration. The Single Point calibration is typically used in the field since it is more convenient. Also, it does not require clean air as one of the calibration points, since clean air cannot be guaranteed in all installations. **A Single Point calibration assumes the unit has already been zeroed.** This is always true for new units from the factory.

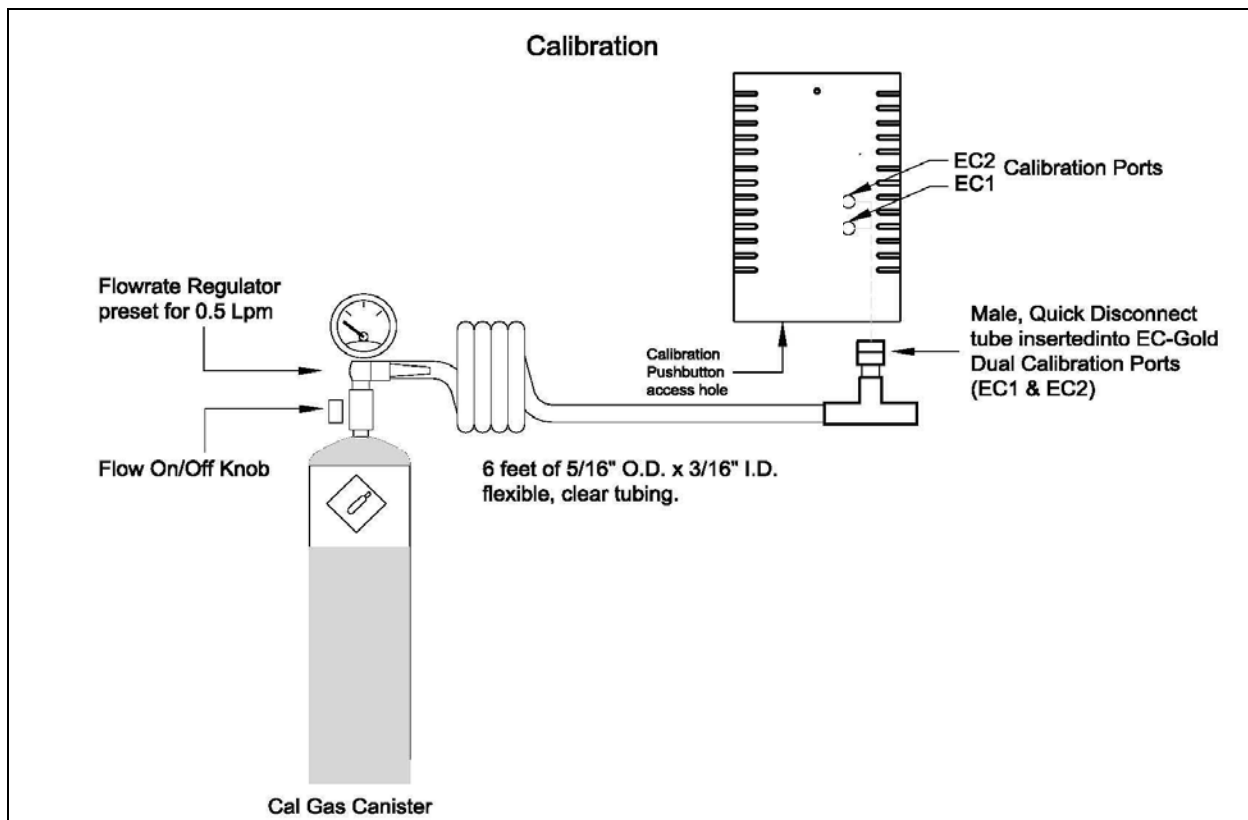

Figure 4.1

4.3.2 SINGLE POINT CALIBRATION

The calibration gas concentration value must be known. The unit comes factory set for Single Point Calibration and 100 ppm CO or 10 ppm NO₂. If either setting is in doubt, then see section 7, controller setting sheet.

1. Determine what Calibration gas concentration the EC-Gold Dual is expecting. This value is listed on the packing slip and may be recorded in the back of the user manual in the CONTROLLER SETTINGS sheet for future reference.

2. The gas sensor is mounted directly behind the Calibration Port in the middle of the front plate of the EC-Gold Dual housing [See Fig. 4.1]. Insert the Quick Disconnect tube into the EC-Gold's Dual Calibration Port.
3. Start gassing the sensor by opening the valve on the canister. The flow rate is preset to 0.5 Lpm (or ~1 SCFH (Standard Cubic Foot per Hour). Wait about 90 seconds.
4. Press and hold the calibration pushbutton (via the access hole – see Fig. 4.1) until the Status LED glows orange acknowledging the calibration request. Release the pushbutton.
5. **If the Status LED remains green after the Calibration pushbutton is released, then the Calibration has been successfully completed.** If the calibration was successful, the Status LED remains green. If there was a calibration error such as not enough change for the gas concentration used, then the Status LED shows red for about 2-3 seconds before reverting back to green.

THIS COMPLETES THE CALIBRATION PROCEDURE FOR STANDARD FEATURE CONTROLLER

5.0 PUSH TO TEST FEATURE

The Push to Test feature allows the customer to verify if the controller is receiving a LOW, HIGH, HIGH HIGH and Total span alarm signals and that ventilation fans, audio alarms etc are working.

Press the Push to Test pushbutton to activate this feature. See Figure 3.0 for the pushbutton location.

When the button is pressed and released, the Status LED starts blinking green on and off every 2 seconds to indicate a test is underway. This feature forces the sensor to Low alarm plus 1ppm.

Press Button again to force High alarm plus 1ppm. Press Button again to force HIGH HIGH alarm (HIGH HIGH alarm plus 1ppm). Press Button again to force span value alarm. Press Button again to get out of Push to Test feature. If Push to Test feature is left ON, it will time out after 30 minutes.

6.0 TROUBLESHOOTING

ERROR DESCRIPTION	WHAT TO DO
1. No Output and all lights off	<ul style="list-style-type: none"> • Check the power to the unit. The voltage should be 24VAC/DC at the power connector with the positive and negative connected as shown on the connector label. • Make sure JP1 is in place for DC voltage • If the Power checks out, call Arjay Service.
2. 4-20mA output does not track the gas concentration.	<ul style="list-style-type: none"> • Make sure that the EC-Gold Dual output mode is set to Analog mode and not to Discrete Voltage Output mode. See Controller Settings Sheet section for details. • Make sure the maximum range of the remote XMTR is the same as the 2nd calibration point. Ex. 20mA=200ppm CO • Calibration may be required. See the calibration section for details. • Call Arjay/Enmet Service for Help if none of the above fixes the problem.
3. In Discrete Voltage Output mode, the ISA-66RLU or Gas Alert connected to the EC-Gold always shows Sensor Fault	<ul style="list-style-type: none"> • Make sure that the EC-Gold DUAL output mode is set to Discrete Voltage Output mode and not to Analog.

7.0 CONTROLLER SETTINGS SHEET

Checked by	
Model Number	
Serial Number	
Hardware Rev.	
Software Rev.	

The factory settings column below lists the typical default settings. The user may change these values at any time. If changed, please fill in the USER SETTING column for future reference.

PARAMETER	DESCRIPTION	FACTORY SETTING	USER SETTING
OUTPUT MODE	There are 2 main output modes : Analog(4-20 mA) and DVO (discrete Voltage Output)		
BUZZER TYPE	Enable or disable the buzzer		
LOW ALARM DELAY TO ON	The minimum time in seconds a Low Alarm must exist before the corresponding relay and indicator are activated.		
LOW ALARM DELAY TO OFF	The minimum time in seconds the Ec-Gold Dual must be out of Low Alarm before the Low Alarm relay and indicator are de-activated		
HIGH ALARM DELAY TO ON	The minimum time in seconds a High Alarm must exist before the High Alarm relay and indicator are activated.		
HIGH ALARM DELAY TO OFF	The minimum time in seconds the Ec-Gold Dual must be out of High Alarm before the High Alarm relay and indicator are de-activated.		
Hi/Hi ALARM DELAY To ON	The minimum time in seconds a Low Alarm must exist before the corresponding relay and indicator are activated.		
Hi/Hi ALARM DELAY To OFF	The minimum time in seconds the Ec-Gold Dual must be out of Low Alarm before the Low Alarm relay and indicator are de-activated		
SENSOR #1	Type or Port.		
	Sensor serial number		
	Gas name		
	Low alarm value		
	High alarm value		
	Hi/Hi alarm value		
	Span Value		

PARAMETER	DESCRIPTION	FACTORY SETTING	USER SETTING
SENSOR #1	First Cal point Enter ppm and corresponding mV e.g. 0ppm= 150mV		
	Second Cal point Enter ppm and corresponding mV e.g. 100ppm=400mV		
SENSOR #2	Type or Port.		
	Sensor serial number		
	Gas name		
	Low alarm value		
	High alarm value		
	Hi/Hi alarm value		
	Span Value		
	First Cal point Enter ppm and corresponding mV e.g. 0ppm= 150mV		
	Second Cal point Enter ppm and corresponding mV e.g. 100ppm=400mV		
SENSOR #3	Type or Port.		
	Sensor serial number		
	Gas name		
	Low alarm value		
	High alarm value		
	Hi/Hi alarm value		
	Span Value		
	First Cal point Enter ppm and corresponding mV e.g. 0ppm= 150mV		
	Second Cal point Enter ppm and corresponding mV e.g. 100ppm=400mV		
SENSOR #4	Type or Port.		
	Sensor serial number		
	Gas name		
	Low alarm value		
	High alarm value		
	Hi/Hi alarm value		
	Span Value		
	First Cal point Enter ppm and corresponding mV e.g. 0ppm= 150mV		
	Second Cal point Enter ppm and corresponding mV e.g. 100ppm=400mV		

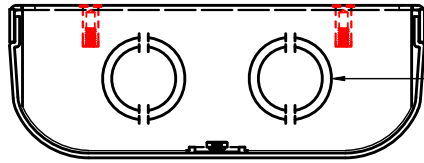

(4) 0.875 Ø x 1.0125 Ø
Double Knock-Outs for
conduit or cable

TOP VIEW

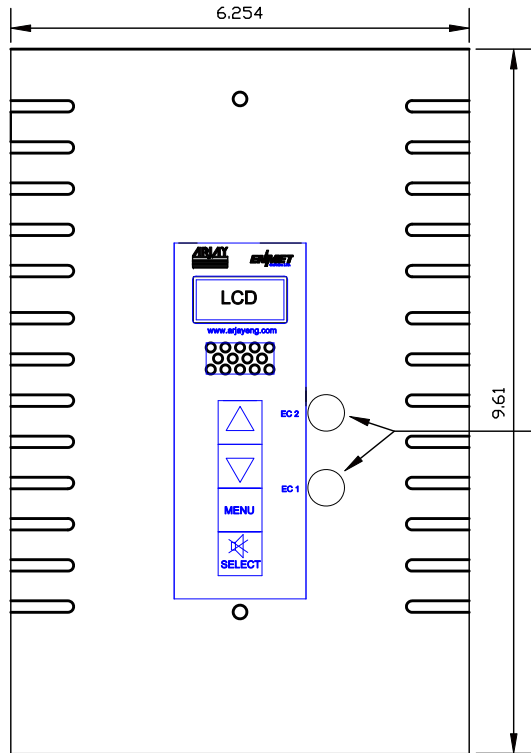

FRONT VIEW with
COVER

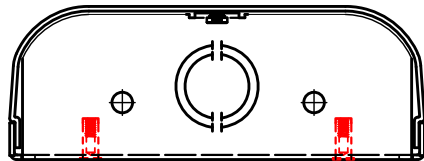

BOTTOM VIEW

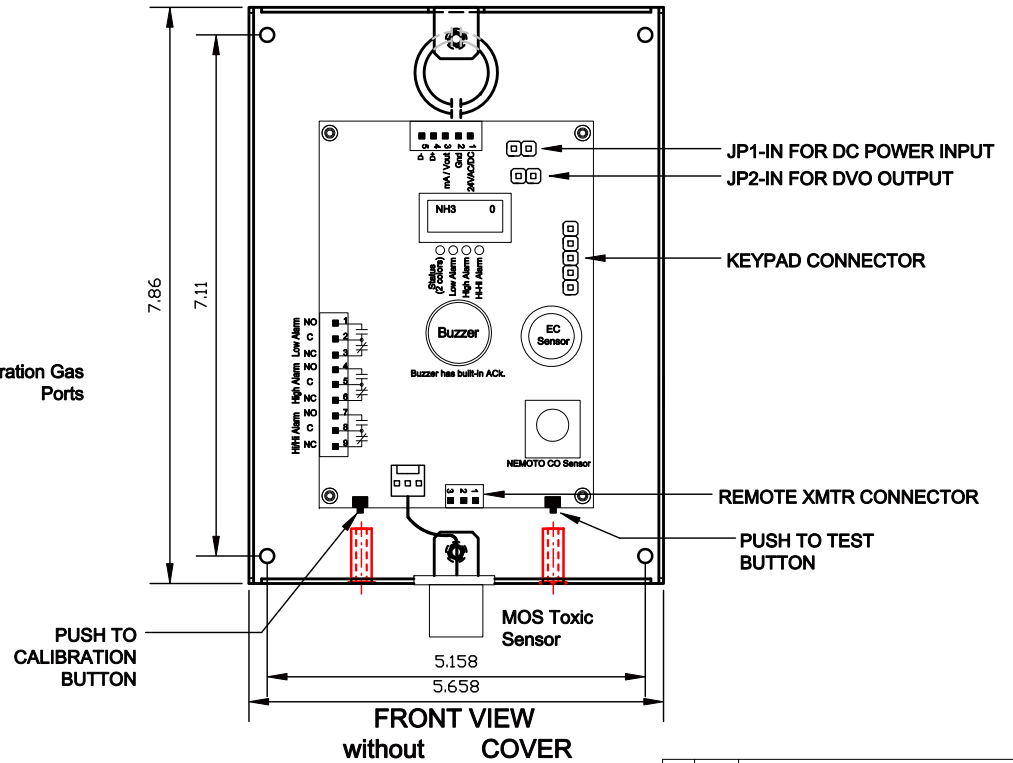

FRONT VIEW
without COVER

1	240910	CHANGED MONOX TO NEMOTO CO SENSOR & ADDED PUSH TO TEST BUTTONS		
REV	DATE	DISCRPTION		CHKD/APPD
REVISIONS				
			PROJECT:	
ARJAY ENGINEERING LIMITED				
DWG STATUS	BY	DATE	TITLE	
DRAWN	P.S.	01/03/07	DUAL EC GOLD INSTALLATION WITH KEYPAD	
CHECKED				
APPROVED				
SCALE	REF. DWG	DWG NO.	SHT.	REV.
N.T.S.		20060392	1	1

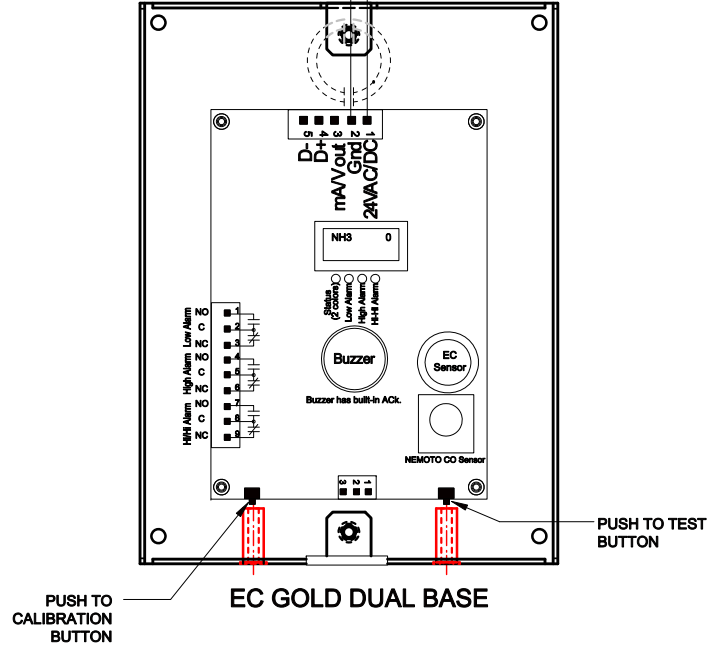
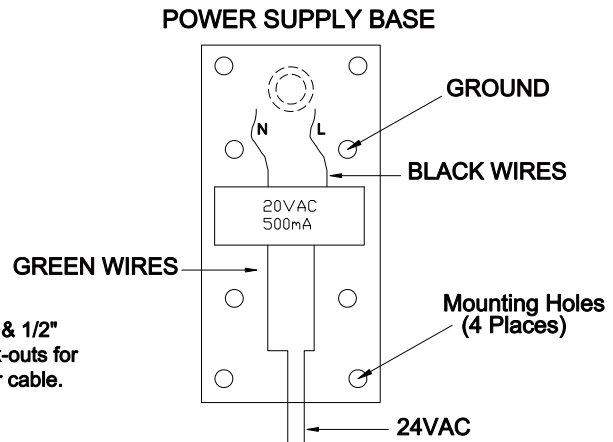
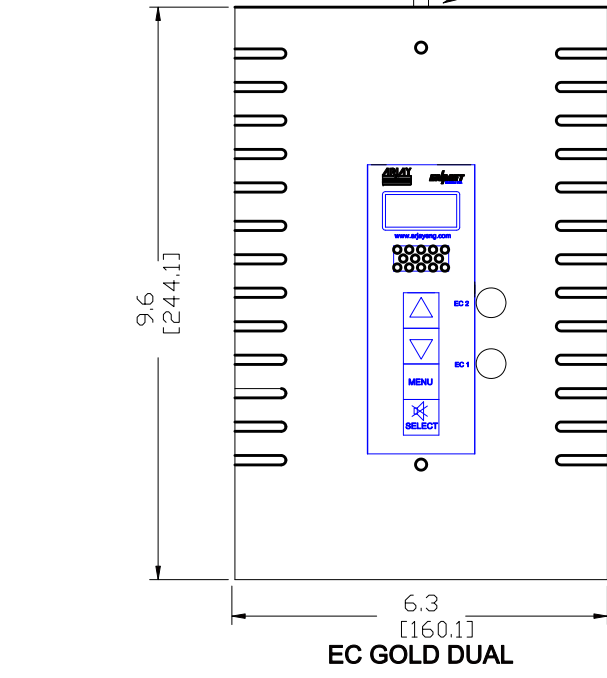
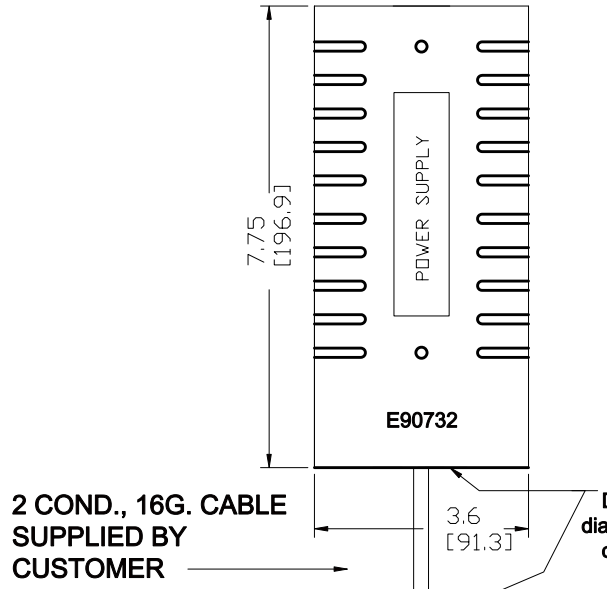

- NOTES:**
1. All dimensions are in inches [mm].
 2. Dimensions of the Dual EC Gold are approx. 9.6 x 6.3 inches.
 3. Dimensions of the Power Supply are approx. 7.75 x 3.6 inches.

3	24/08/10	CHANGED MONOX TO NEMOTO CO SENSOR & ADDED PUSH TO TEST BUTTONS		
2	16/01/08	Changed part number from A00650 to E90732.		
1	13/07/07	Changed power supply to 500mA.		
REV	DATE	DISCRIPTION	CHKD	APP'D
REVISIONS				
		ARJAY ENGINEERING LIMITED		PROJECT:
DWG STATUS	BY	DATE	TITLE	
DRAWN	P.S.	22 03 07	DUAL EC GOLD WITH E90732 POWER SUPPLY	
CHECKED				
APPROVED				
SCALE	REF. DWGS	DWG NO.	SHT.	REV.
N.T.S.		20070121	1	2



MAINTENANCE AND CALIBRATION

Your **ARJAY / ENMET** gas detector is the state of the art in gas detection, but like any other part of your ventilation system, it requires periodic maintenance and calibration.

There are various sensor technologies that may be used in your Arjay gas monitor; including solid state MOS, Electrochemical, Infrared and Pellister Pair (Hot wire). These have a normal operating life of 3 to 5 years under ambient conditions. You should consider a preventive maintenance schedule whereby you test your system on a periodic basis to ensure its proper calibration and operation.

For solid state (MOS) sensors, we recommend calibration every 3 to 4 months for a typical garage application. For Electrochemical sensors, we recommend calibration every 6 months for a typical garage application. Pellister Pair we recommend every 3 to 4 months and Infrared we recommend every 6 months. For applications that are more sensitive, or where internal policies exist, a higher frequency of calibration may be required. This is a simple procedure which will indicate any problems with your system. A test and calibration kit may be purchased from **ARJAY ENGINEERING** for this purpose. Parts are also readily available from our facility.

MAINTENANCE CONTRACT

Alternatively you may wish to consider a Maintenance Contract with **ARJAY ENGINEERING** whereby one of our service technicians comes to your site and checks out the unit for proper calibration and operation on a regularly scheduled basis. This is done on a flat per annum fee. All parts are extra. Typical target gases are included, however, exotic or specialty gases may have a surcharge. If you wish us to quote a Maintenance Contract fill in the section below and return to our office.

COMPANY:			
ADDRESS:			
CONTACT PERSON:			
PHONE:		FAX:	
EMAIL:			
MODEL AND SERIAL NO. OF GAS DETECTOR:			

Fax to address below or e-mail to arjay@arjayeng.com

ARJAY ENGINEERING LTD
 2851 Brighton Rd
 Oakville, Ontario, Canada L6H 6C9



Telephone: +1 (905)-829-2418
Telefax: +1 (905)-829-4701
N. America Toll: (800)-387-9487
Internet: www.arjayEng.com
E-Mail: arjay@arjayEng.com



ARJAY ENGINEERING LTD. GUARANTEE

We hereby guarantee this instrument to be free from defects in workmanship and materials, and if found defective in workmanship or materials, upon being returned to our factory, prepaid, within one year from date of purchase, it will be repaired or replaced at factory without charge. However, if upon being returned and after inspection, there is evidence that the instrument has been subjected to tampering, careless handling, improper or faulty application or installation, the above guarantee shall not be applicable, and we shall have the right in any such case to make a charge to cover the cost of repairs, servicing and transportation expense. The undersigned assumes and shall have no liability for consequential damages resulting from the use or misuse of the instrument.

The foregoing guarantee is in lieu of all other guarantees or warranties, expressed or implied, and all other obligations or liabilities, contractual or otherwise, either to the original purchaser of said instrument, or to any other person whomever.

BY: ARJAY ENGINEERING LTD.

For service, call ARJAY Engineering Ltd. directly: Canada (905) 829-2418

North American Toll Free: 1-800-387-9487

Fax: (905) 829-4701

Internet: www.arjayeng.com

E-mail: arjay@arjayeng.com

ARJAY ENGINEERING LTD

2851 Brighton Rd
Oakville, Ontario, Canada L6H 6C9



Telephone: +1 (905)-829-2418
Telefax: +1 (905)-829-4701
N. America Toll: (800)-387-9487
Internet: www.arjayEng.com
E-Mail: arjay@arjayEng.com