

DENSITÉ series

AAP-1741

Four Channel Analog Audio Processor

Guide to Installation and Operation

M768-8200-100

6 Jun 2007



Miranda Technologies Inc.

3499 Douglas-B.-Floreani
St-Laurent, Québec, Canada H4S 1Y6

Tel. 514-333-1772

Fax. 514-333-9828

www.miranda.com

© 2007 Miranda Technologies Inc..

Safety Compliance Information

Safety Compliance

This equipment complies with:

- CSA C22.2 No. 60950-1-03 / Safety of Information Technology Equipment, Including Electrical Business Equipment.
- UL 60950-1 (1st Edition) / Safety of Information Technology Equipment, Including Electrical Business Equipment.
- IEC 60950-1 (1st Edition) / Safety of Information Technology Equipment, Including Electrical Business Equipment.

CAUTION

These servicing instructions are for use by qualified service personnel only. To reduce the risk of electric shock, do not perform any servicing other than that contained in the operating instructions unless you are qualified to do so. Refer all servicing to qualified service personnel. Servicing should be done in a static-free environment.

Electromagnetic Compatibility

- This equipment has been tested for verification of compliance with FCC Part 15, Subpart B, class A requirements for Digital Devices.
- This equipment complies with the requirements of:
EN 55022 Class A, Electromagnetic Emissions,
EN 61000-3-2 & -3-3, Disturbance in Supply Systems
EN 61000-4-2, -3, -4, -5, -6, -8 & -11 Electromagnetic Immunity

How to contact us:

For technical assistance, please contact the Miranda Technical support centre nearest you:

Americas

Telephone:

+1-800-224-7882

e-mail:

techsupp@miranda.com

Asia

Telephone:

+81-3-5730-2987

e-mail:

asiatech@miranda.com

Europe, Middle East, Africa, UK

Telephone:

+44 (0) 1491 820222

e-mail:

eurotech@miranda.com

France (only)

Telephone:

+33 (0) 1 55 86 87 88

e-mail:

eurotech@miranda.com

Visit our web site at www.miranda.com

Table of Contents

1 AAP-1741 Four Channel Analog Audio Processor..... 1

1.1 Introduction 1

1.2 Features 1

1.3 Applications 2

1.4 Functional Block diagram..... 2

1.5 Card front-edge layout 3

2 Installation 4

2.1 Unpacking 4

2.2 Installation in the Densité frame..... 4

2.2.1 Rear Panel Options..... 4

3 Operation 5

3.1 Control options 5

3.2 Local control using the Densité frame control panel..... 5

3.2.1 Status LED 6

3.2.2 Menu for local control..... 7

3.3 Remote control using iControl..... 10

3.3.1 Audio Processing 12

3.3.2 Dynamic Processing 14

3.3.3 Audio Output 16

3.3.4 UP/DOWN MIX 18

3.3.5 Audio Type 21

3.3.6 RALM tab: 22

3.3.7 A-BUS 23

3.3.8 Reference Input..... 24

3.3.9 Rear Type 25

3.3.10 Factory / Presets..... 25

3.3.11 Options..... 27

3.3.12 Alarm Configuration 27

3.3.13 Info 28

4 Specifications 29

GUIDE TO INSTALLATION AND OPERATION

1 AAP-1741 Four Channel Analog Audio Processor

1.1 Introduction

The AAP-1741 is a four-channel high quality audio processor designed to work alone or with a wide range of video converters, frame synchronizer proc/amps of the Densité series.

The card features two distinct processing blocks: Input and Output. The input processing includes Dolby detection, Tone generator, delay adjustments, level controls and phase correction. Delay components include a fixed delay of up to 2 seconds as well as a video tracking delay that will automatically track the varying saw tooth delay introduced by an associated video frame synchronizer.

The output processing block includes full channel shuffling, an additional gain/attenuation stage and mixing. Each odd output channel is a mix of any two input channels, and a 4-channel mixing is available on the even output channels.

Additional audio functions such as dynamic processing (compressor/limiter and expander) and/or Down and Up mixing are proposed as options.

With a card-to-card Audio bus, the AAP-1741 provides processing for 8 channels originating from a video card. Once processed, the signals are sent back to be embedded, and are also available at the analog outputs.

Along with the audio channels, the Audio bus carries the timing, delay signaling and Dolby Metadata. When combining cards together all audio processing is synchronous and in phase, ensuring proper alignment and matched delay. The AAP-1741 can work with one video card and/or one other audio processor card.

An input audio signal status is also available indicating the input signal presence or overload.

The card is housed in a (DENSITÉ) frame, with a single or double width rear connector panel.

1.2 Features

- 8 channel processing of embedded audio signals.
- Stand-alone 8 channel audio processor and delay.
- Fixed delay and up to 8 video frames tracking delay
- Full channel shuffling on the outputs
- 2 and 4 channel mix-down
- Audio metering data for audio levels and phase over IP.
- Dolby E compatibility
- Analog audio inputs and outputs
- Full quality 24 bit audio converters
- Balanced AES3 or unbalanced AES3-id I/Os
- -96 to +12 dB of input and output level adjustments (0.5 dB steps)
- Separate input and output 0 dBFS adjustments (0 to +24 dBu, 1 dB steps)
- Locks to video card, frame reference or AES input

- Internal digital EBU tone generator
- Absence signal delay and threshold adjustable /channel
- Overload detection
- All settings through frame control panel or remotely
- Status LED and alarms remote reporting

1.3 Applications

- With a DEC-1xxx in Incoming feeds applications as A to D converter and audio processor.
- Companion to an ENC-1xxx as an audio proc and a final D to A converter.
- Stand-alone or associated with an FRS-1xxx as an audio processor with analog inputs and outputs.

1.4 Functional Block diagram

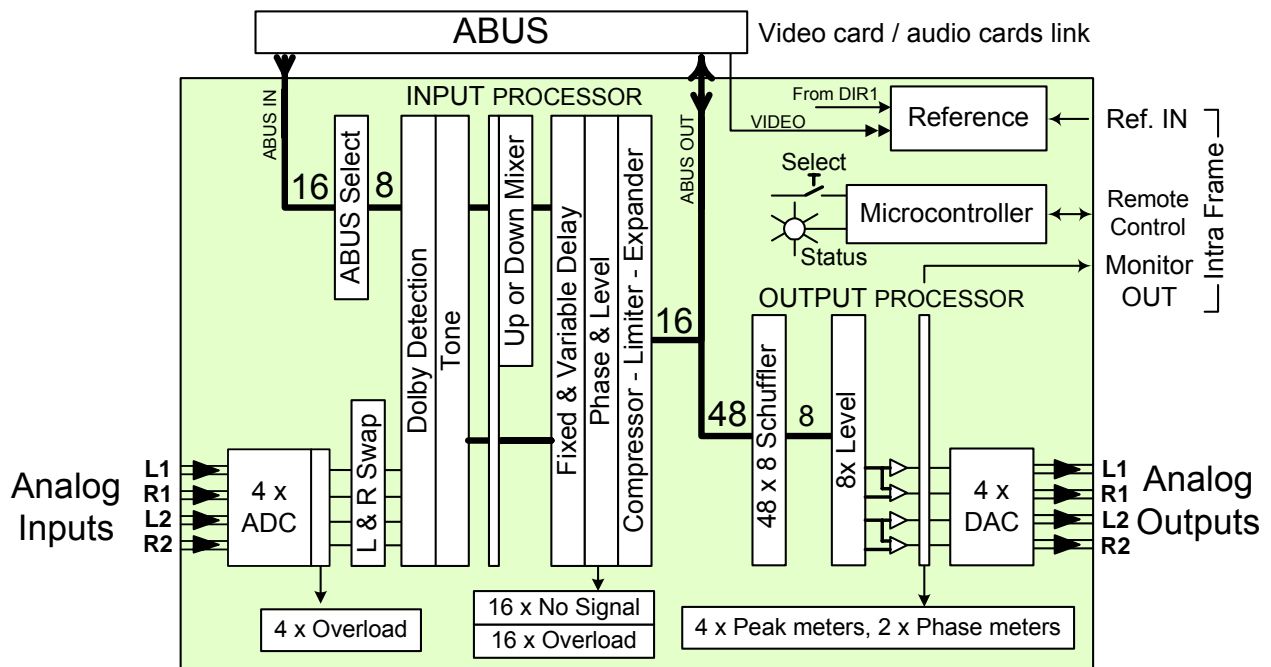

1.5 Card front-edge layout

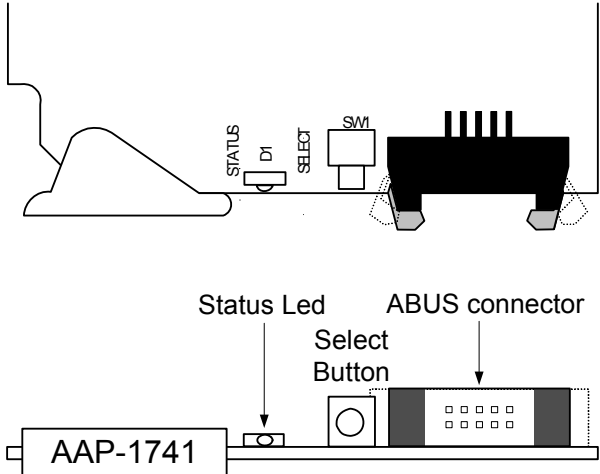

2 Installation

2.1 Unpacking

Make sure you have ordered and received the AAP-1741 and its associated rear panel. If any of the following items are missing, contact your distributor or Miranda Technologies Inc.

- AAP-1741 4-Channel Analog Audio Processor
- One of the AAP-1741 Rear Panels (see figure)
- An ABUS flat cable

2.2 Installation in the Densité frame

The AAP-1741 must be mounted in a DENSITÉ frame. The installation includes both the AAP-1741 module, and the rear panel module. It is not necessary to switch off the frame's power when installing or removing the card.

When the AAP-1741 is used in conjunction with a video module such as FRS-1101 and/or another audio module like AAP-1741 or UAP-1783, the ABUS flat cable must be installed between the ABUS connectors.

- **Note:** for a two card installation, use the two end connectors of the flat cable and leave the middle one unplugged.

Detailed instructions for installing cards and their associated rear panels in the Densité frame are given in the Densité Frame manual.

2.2.1 Rear Panel Options

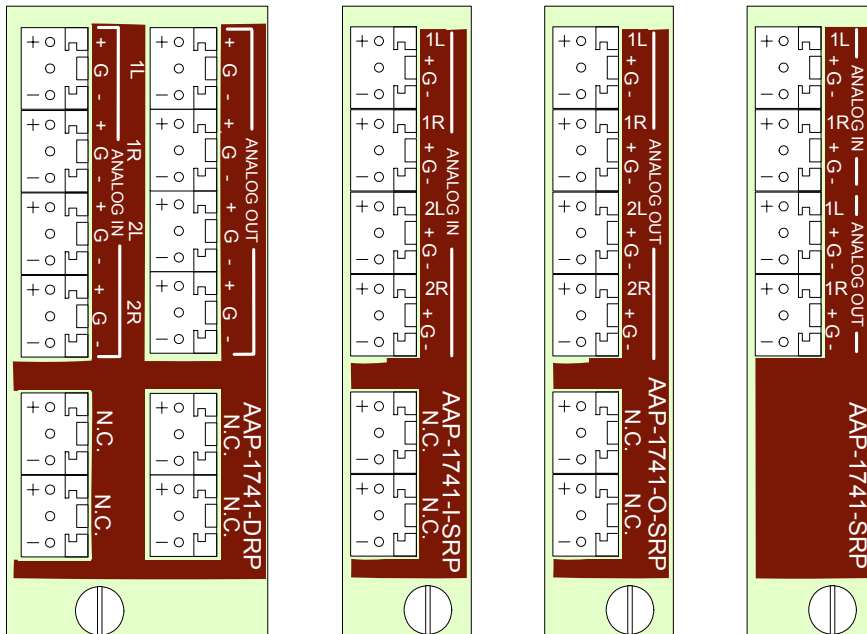

3 Operation

3.1 Control options

The AAP-1741 has two primary control interfaces:

- The local control panel attached to the Densité frame's controller
- Remote control using Miranda's iControl system

These will be explained in detail in the following sections.

3.2 Local control using the Densité frame control panel

Push the SELECT button on AAP-1741 card edge (see Section 1.5) to assign the local control panel to operate the AAP-1741. Use the control panel buttons to navigate through the menu, as described below.

All of the cards installed in a Densité frame are connected to the frame's controller card, which handles all interaction between the cards and the outside world. There are no operating controls located on the cards themselves. The controller supports remote operation via its Ethernet ports, and local operation using its integrated control panel.

The local control panel is fastened to the controller card by a hinged connector, and when installed is located in the front center of the frame, positioned in front of the power supplies. The panel consists of a display unit capable of displaying two lines of text, each 16 characters in length, and five pushbuttons.

The panel is assigned to operate any card in the frame by pushing the SELECT button on the front edge of that card. Pushing the CONTROLLER button on the control panel selects the Controller card itself. The STATUS LED on the selected card flashes yellow.

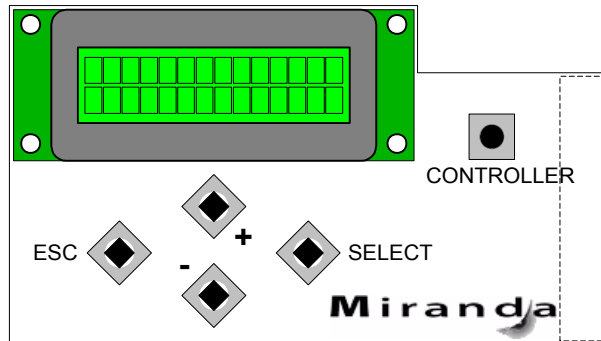

The local control panel displays a menu that can be navigated using the four pushbuttons located beneath the display. The functionality of the pushbuttons is as follows:

- [CTRL] Selects the controller card for status monitoring and adjustment
- [+] [-] Used for menu navigation and value modification
- [SELECT] Gives access to the next menu level. When a parameter value is shown, pushing this button once enables modification of the value using the [+] and [-] buttons; a second push confirms the new value
- [ESC] Cancels the effect of parameter value changes that have not been confirmed; pushing [ESC] causes the parameter to revert to its former value.

Pushing [ESC] moves the user back up to the previous menu level. At the main menu, [ESC] does *not* exit the menu system. To exit, re-push the [SELECT] button for the card being controlled.

If no controls are operated for 30 seconds, the controller reverts to its normal standby status, and the selected card's STATUS LED reverts to its normal operating mode.

3.2.1 Status LED

The status monitor LED is located on the front card-edge of the AAP-1741, and is visible through the front access door of the DENSITÉ frame. This multi-color LED indicates module status by color, and by flashing/steady illumination, according to the chart. The chart also indicates fault reporting for this card on the DENSITÉ frame's serial and GPI interfaces.

	Serial Report	GPI Report	Green	Yellow	Red	Flashing Red	Flashing Yellow
Card system error	✳			✳			-
Not expected reference Error	✳			✳			-
Reference error	✳				✳		
NSD CH 1 to 4 Analog input	✳			✳			-
NSD CH 9 to 16 (Ext.CH 1/8 or 9/16)	✳			✳			-
OVERLOAD CH 1 to 4 analog inputs	✳				✳		
OVERLOAD CH 1 to 16 processing	✳				✳		-
OVERLOAD analog outputs 1 to 4	✳						
Any TONE activated	✳			✳			-
Any output Mute	✳			✳			-
User attention	-	-	-	-	-	-	Yes
Rear panel error	-	-	-	-	-	Yes	-
FPGA error	-	-	-	-	-	Yes	
✳ : Factory default.							
Note: The non-requested message posting to an alarm status can only be accessed by the communication protocol (serial port)							

NOTE: A “Flashing Yellow” Status LED indicates that the SELECT button on the front panel has been pushed.

3.2.2 Menu for local control

The AAP-1741 has operating parameters which may be adjusted locally at the controller card interface. After pressing the SELECT button on the AAP-1741 module, use the keys on the local control panel (described in the Controller card manual) to step through the displayed menu and adjust the parameters. The menus are shown below.

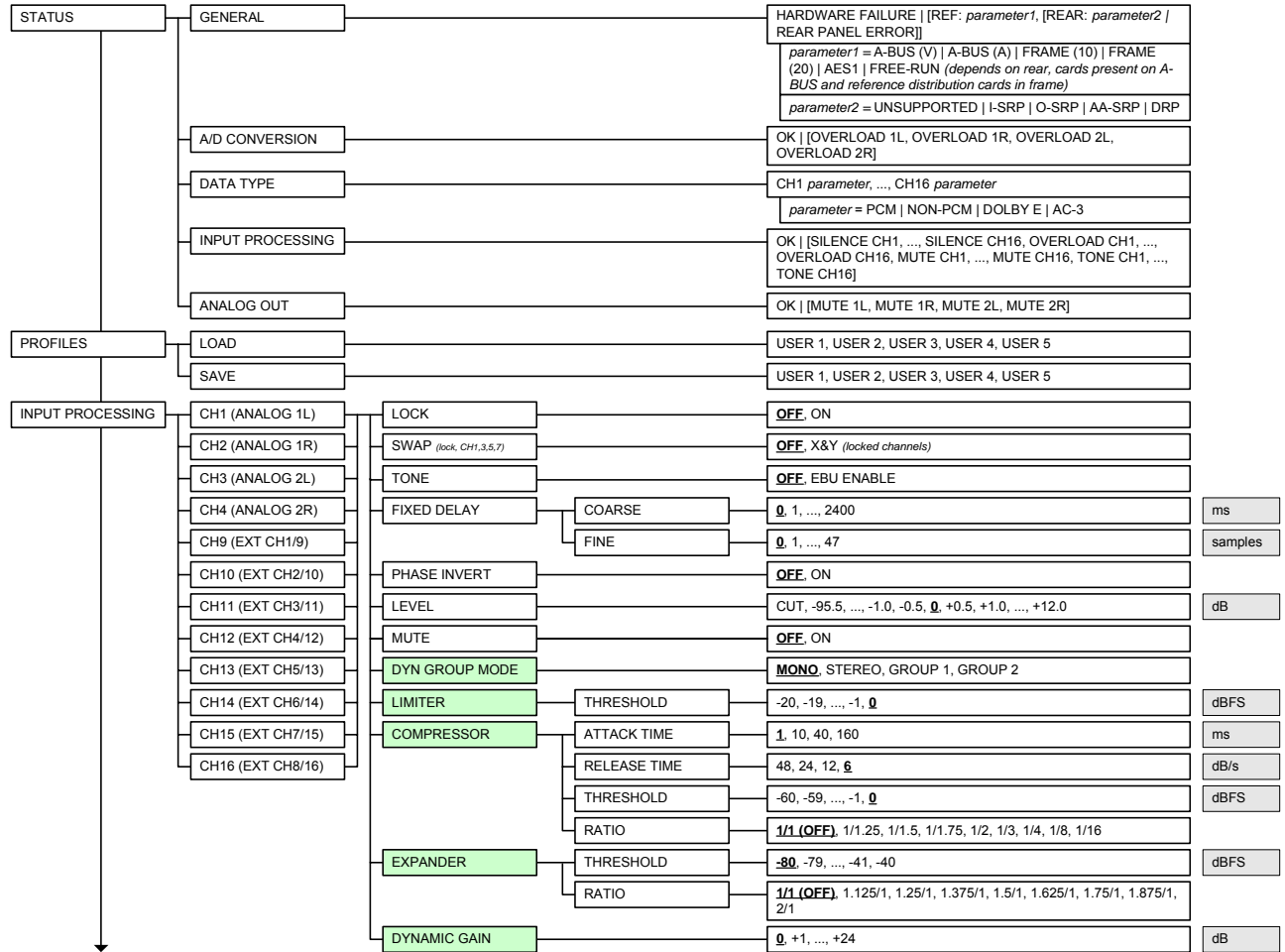

GUIDE TO INSTALLATION AND OPERATION

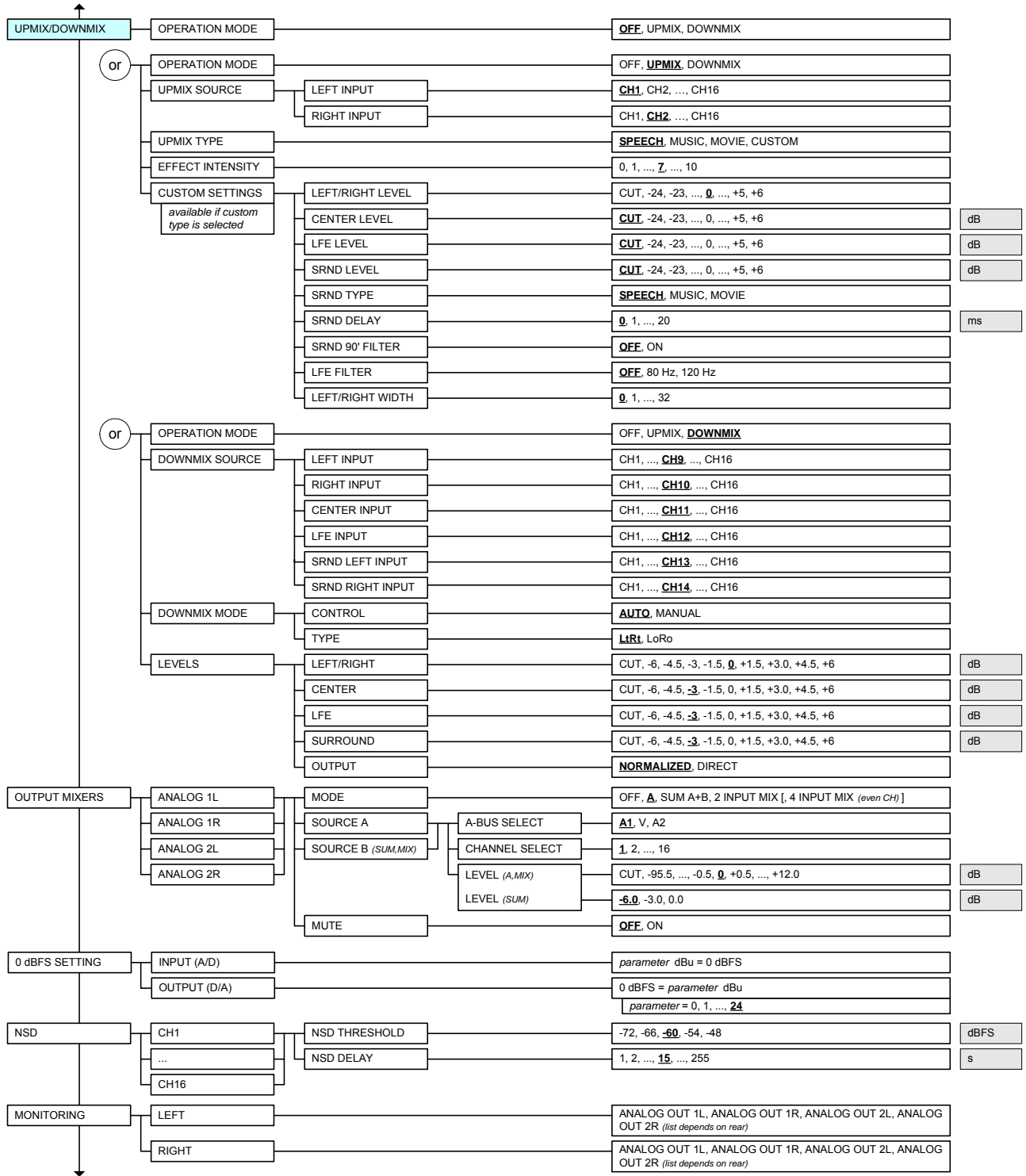

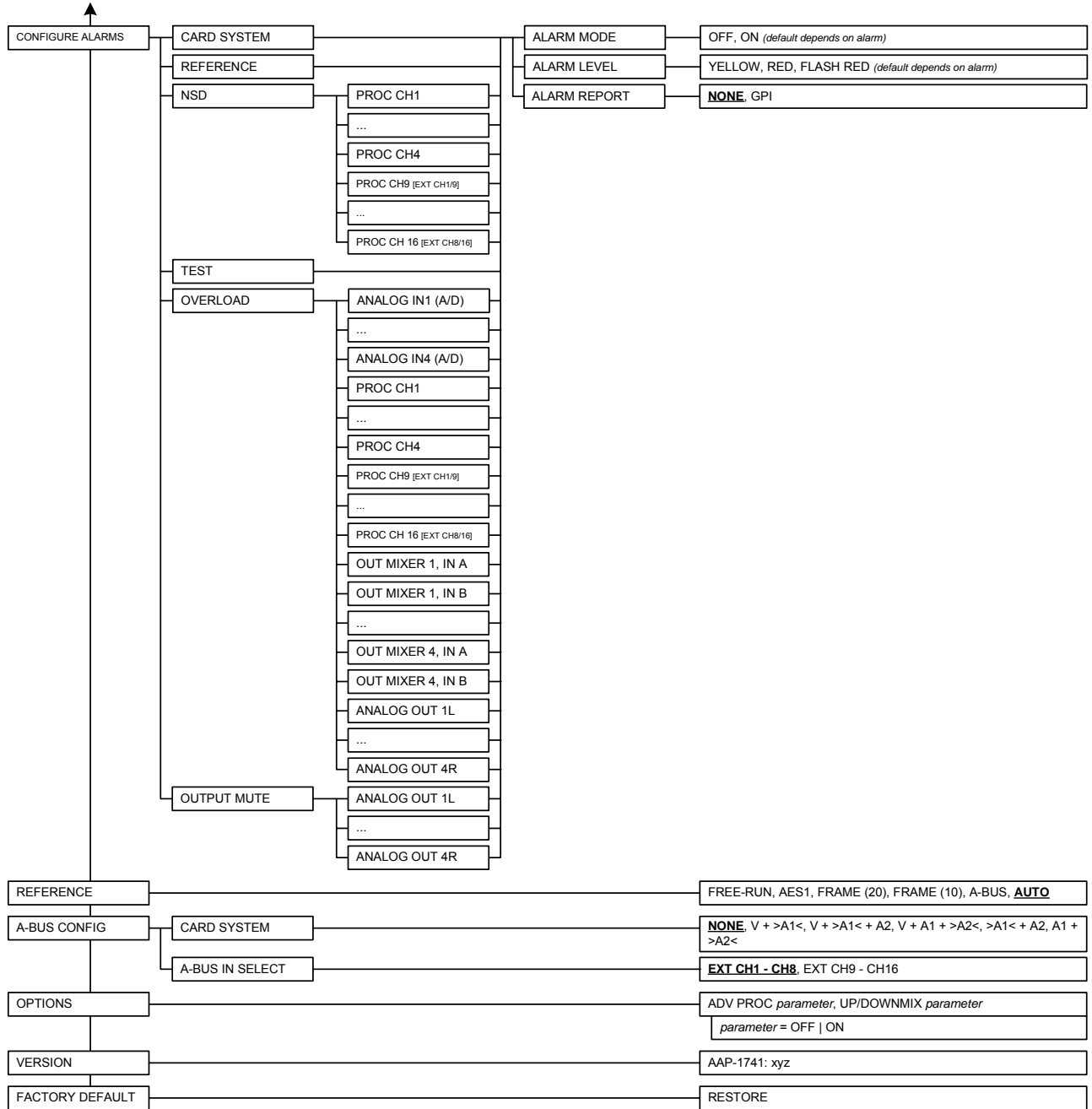

3.3 Remote control using iControl

The operation of the AAP-1741 may be controlled using Miranda's iControl system.

- This manual describes the control panels associated with the AAP-1741 and their use.
- Please consult the iControl User's Guide for information about setting up and operating iControl.

In iControl Navigator or iControl Websites, double-click on the AAP-1741 icon to open the control panel.

Note the following features of this panel:

Panel selection buttons

The buttons on the left side of the panel are used to select the contents of the right portion of the screen.

- The selected button is highlighted, and the main screen heading matches the button name.

The column of buttons can be hidden or revealed by clicking the arrow icon at the left-hand side (compare the two figures on the right).

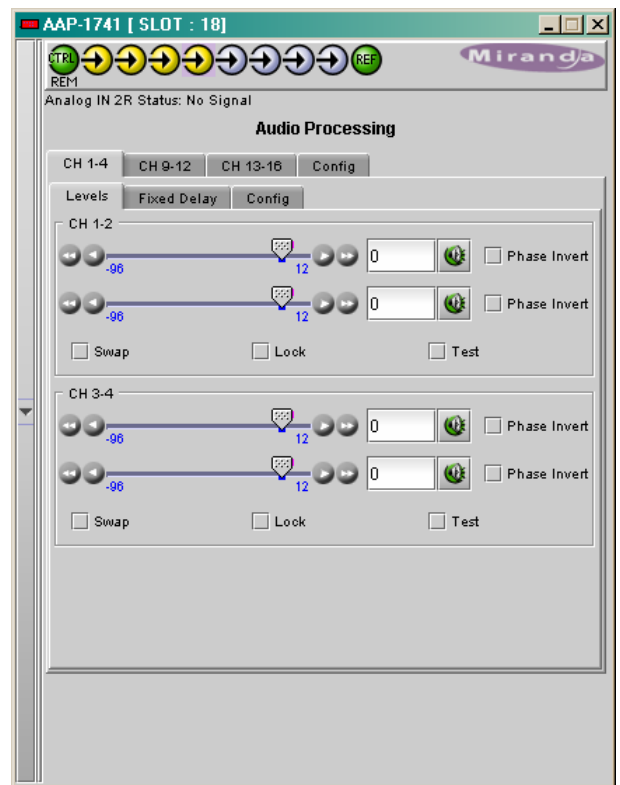
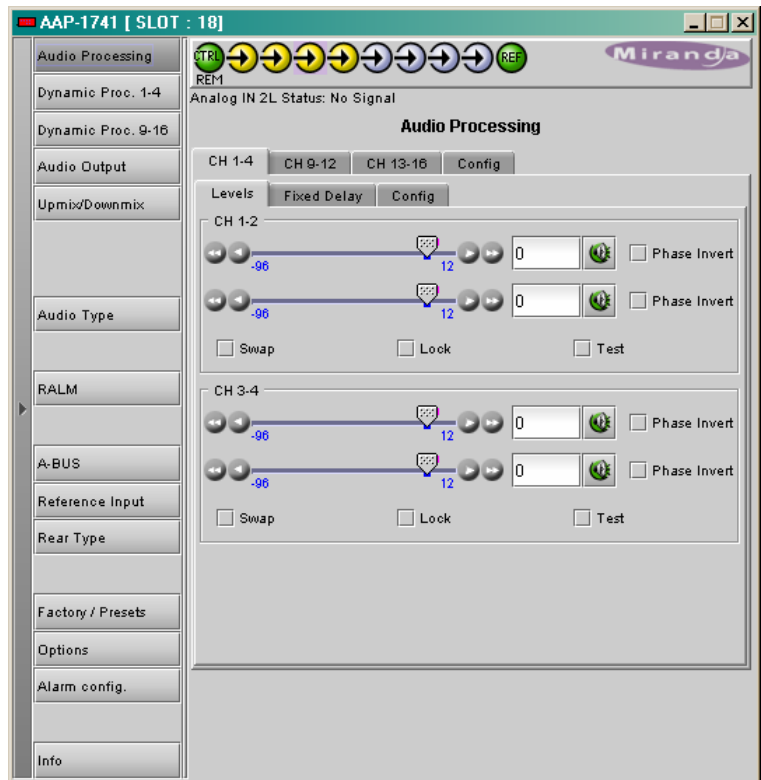

All of the individual control panels are described in detail below.

Panel	See Page
Audio Processing	12
Dynamic Proc. 1-4	14
Dynamic Proc. 9-16	15
Audio Output	16
UP/DOWN MIX	18
Audio Type	21
RALM	22
A-BUS	23
Reference Input	24
Rear Type	25
Factory / Presets	25
Options	27
Alarm Config.	27
Info	28

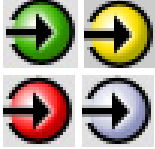

Status Icons

At the top, to the left of the Miranda logo, are ten status icons that report various aspects of the card's operation.

Icon #	Indicates	appearance	interpretation
1	Card control status		Green if the card is controlled remotely Yellow when locally controlled
2 - 9	Input status		Green if OK, Yellow if warning detected. Red if error detected Grey if detection is disabled <i>Note: Each input error can be masked independently</i>
10	Reference status		Green if OK, Red if an error has been detected or there is no reference connected Grey if reference error reporting is disabled

Move the cursor over an icon to see its current status in the message area below the icons. If there is an error status, the message will appear automatically. If there are multiple error messages, the display will cycle through them

3.3.1 Audio Processing

3.3.1.1 Audio Processing - CH 1-4 to CH 13-16 tabs

The channels 1 to 4 are the analog inputs. When a video card is present, eight extracted audio channels are available as **Channel 9** to **Channel 16**, see **ABUS Input Section** (page 23).

Each of these tabs controls the input processing: Levels, Fixed Delays and configuration for the absence signal detection for two pairs of channels; each channel is provided with a set of controls.

Levels sub-tab: grouped by pair of channels, each channel has the following controls: a Level slider (from -96 to 12 dB), an input box where the desired level may be input directly, a Mute icon button and a Phase Invert checkbox.

At the bottom are three checkboxes:

- **Swap** – allows channel swapping inside a pair.
- **Lock** – locks both channel sliders together for levels and delay, so that moving one slider moves the other one as well.
- **Test** – replaces the input signal with a stereo test tone.

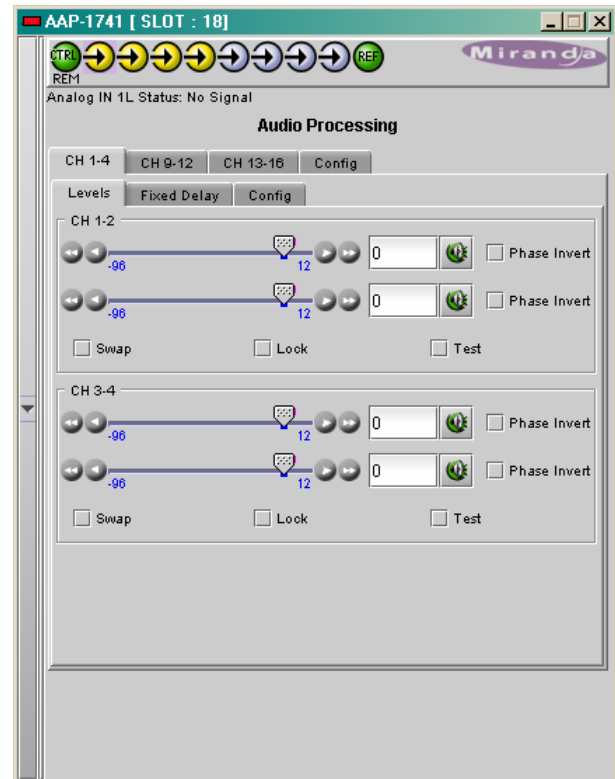

Fixed Delay sub-tab: adds an audio delay to the signal. For each channel, two sliders allow delay to be adjusted.

- **Coarse** – adjusts the delay in ms, from -100 ms to 2400 ms
- **Fine** – adjusts the delay in sample increments, from -47 to 47.

Input data boxes are available to enter numerical values directly.

The negative values will be applied only when the AAP-1741 is slave of a video card via ABUS. The positive small values desired have to be larger than the minimum processing delay to be effective.

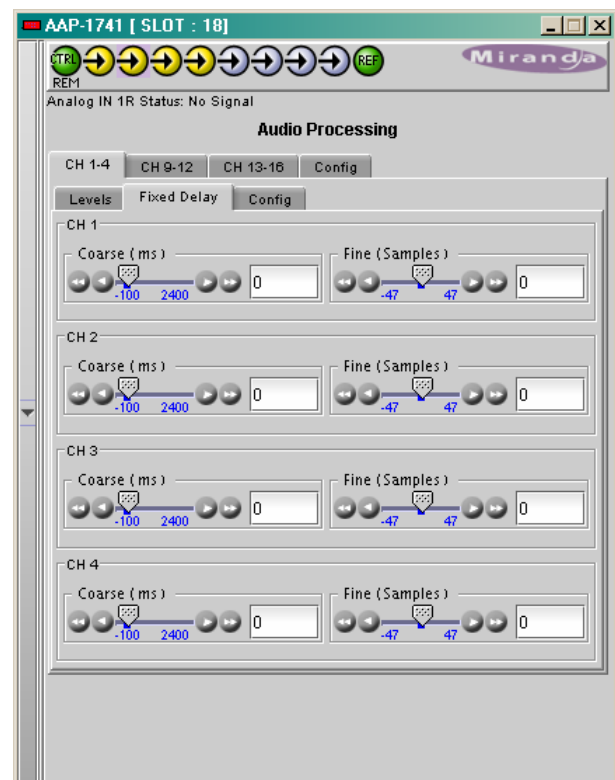

Config sub-tab: this tab sets the card's behaviour in the event of a loss or absence of audio signal.

- A signal absence is declared when the signal level is lower than the signal **threshold** during the selected period. The **threshold** can be set through the pull-down box to -72, -66, -60, -54 or -48 dBFS, the default value is -60 dBFS.

Delay: the amount of time for which the signal must be below the threshold before a signal absence error is reported can be adjusted from 0 to 255 seconds. The default value is set to 15 s, and an input box is available to enter a numerical value directly

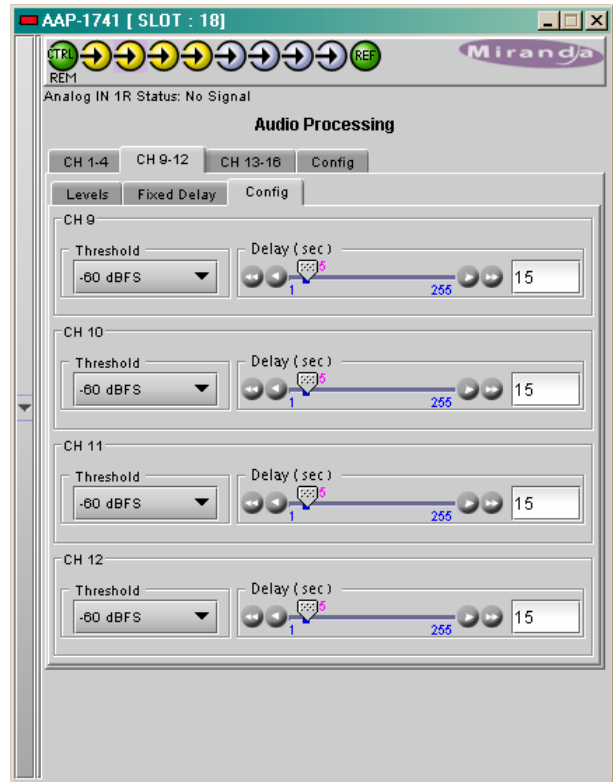

3.3.1.2 Audio Processing - CONFIG tab

Audio Proc Input Selection: when a video card is present, up to sixteen extracted audio channels may be present. The pull-down box allows the feed for the 8 internal processing audio channels 9 to 16 to be selected, either the extracted audio channels 1 to 8 or 9 to 16.

Input 0 dBFS: the analog to digital conversion ratio is adjusted with a pull-down box. The possible values are from 0 to +24 dBu for 0 dBFS (digital full scale).

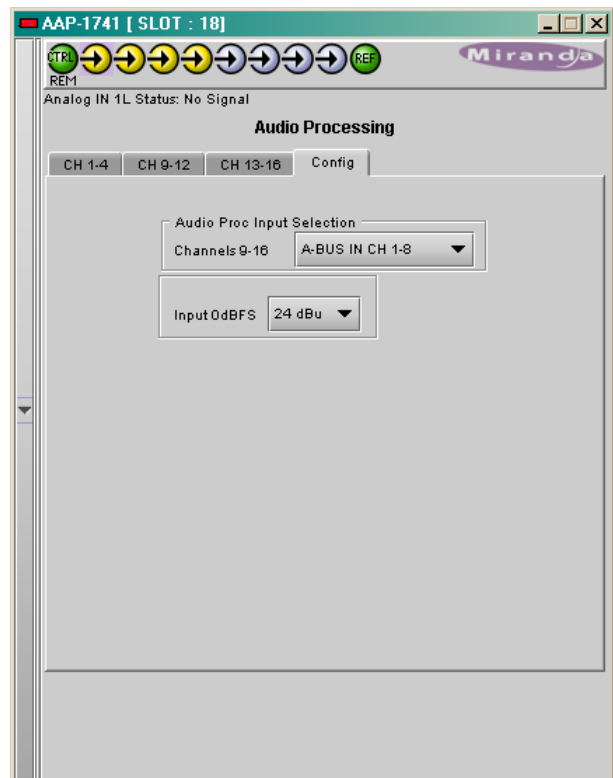

3.3.2 Dynamic Processing

This process is part of the input processor, refer to the block diagram.

3.3.2.1 CH 1 to CH 4 tabs:

Each of these tabs controls the dynamic processing for one channel. The available functions are Limiter, Compressor, and Downward Expander. A Gain trim allows compensation of the loudness attenuation that follows compression.

A graphic of the input to output transfer function, **VU** and **PEAK** meters for the program, and compression meter will facilitate the adjustments for each channel. Eight channel metering is active for one minute only after any setting modification on the current tab, or after a click on **Dynamics for 1 min** box.

At any time a **Bypass Settings** checkbox allows immediate comparison between processing ON or OFF.

The **Mode** pull-down menu is used to link two or more channels, so they can share the same dynamic controls to keep a coherent stereo or multi channel image. The stereo choice links an odd channel with (odd + 1) channel.

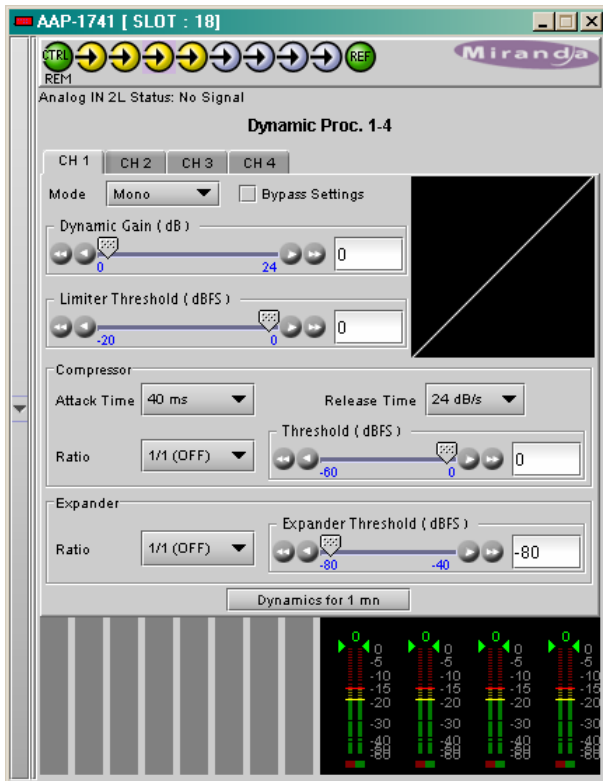

The **Dynamic Gain** is adjusted from 0 to +24 dB gain with the slider or a direct keyboard entry.

The **Limiter Threshold** is adjusted from 0 to -20 dBFS with the slider or a direct keyboard entry. 0 is the default value and corresponds to **Limiter** OFF. For analog inputs, the correspondence between the dBFS and the dBu values depends on the Input 0 dBFS setting (**Audio Processing** Tab - **Config** sub-tab).

The proposed parameters for the **Compressor** are the **Attack Time**, **Release Time**, **Threshold** and **Ratio**. The Threshold is adjustable with a slider between -60 and 0 dBFS, 0 is the default value and corresponds to an OFF position. The other parameter values are accessible via pull-down boxes.

The proposed parameters for the downward **Expander** are **Threshold** and **Ratio**. The output on input ratio of 1/1 is the default value and corresponds to the OFF position. The **Threshold** is accessible via a pull-down box.

At the bottom of the tab, from left to right, appear the dynamic meters and the **VU** and **PEAK** meters. The dynamic meter moves downward and gives the attenuation applied to the audio channel, the **Dynamic Gain** effect is not displayed. The top of the scale is for 0 dB. The scale goes from 0dB at the top to -31 dB at the bottom.

- The VU meter is displayed with a bar and the PEAK meter with a dot.

3.3.2.2 CH 9 to CH 16 tabs:

The functions are same as above but for channels 9 to 16.

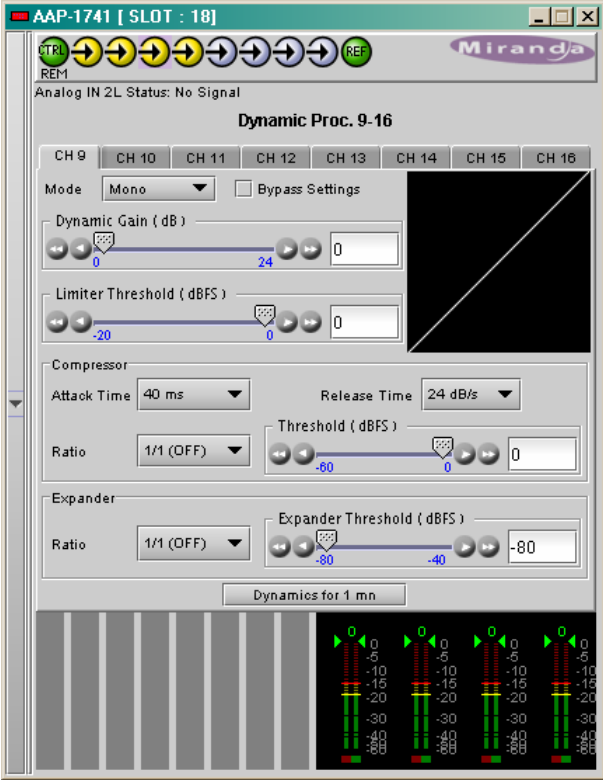

3.3.3 Audio Output

3.3.3.1 Audio Output - CH 1-2 to CH 3-4 tabs:

Each of these tabs controls the output processing for two output channels – source selectors, level controls and mixers for each output.

A coloured box indicates the audio type for each output of the card.

- Detected audio types can be PCM, AC3 (Dolby Digital), Dolby E or N-PCM (other non-PCM).

The Operation Mode pulldown establishes the configuration of the controls for an output channel. There are four options:

A (see CH 1 in the figure on the right)

The source is selected using the Source A ABUS Select and Channel pulldowns, and its level is adjusted using the slider or data box.

- The ABUS select options are:
 - **V** selects one of the 16 channels from the video card.
 - **A1** selects one of the 16 channels from an audio card. A1 is always Local, Slave 1 or Master
 - **A2** selects one of the 16 channels from an audio card. A2 is always Slave2 or Slave.
- The output Level is adjustable from -96 to +12 dB with the slider or a direct keyboard entry.

SUM (A+B) (see CH 2 in the figure on the right)

Two sources are selected using the Source A and Source B ABUS Select and Channel pulldowns. The two sources are added, and the level of the combined signal is attenuated by the amount selected in the Sum (A+B) LEVEL pulldown.

- The ABUS select options are:
 - **V** selects one of the 16 channels from the video card.
 - **A1** selects one of the 16 channels from an audio card. A1 is always Local, Slave 1 or Master
 - **A2** selects one of the 16 channels from an audio card. A2 is always Slave2 or Slave.
- The *Sum (A+B) Level* pulldown offers attenuations of 0 dB, -3 dB and -6 dB.

NOTE: If you attempt to mix two different audio types to an output, only the Source A signal will be routed to this output and the Source A audio type will be displayed. The Source B signal will be ignored.

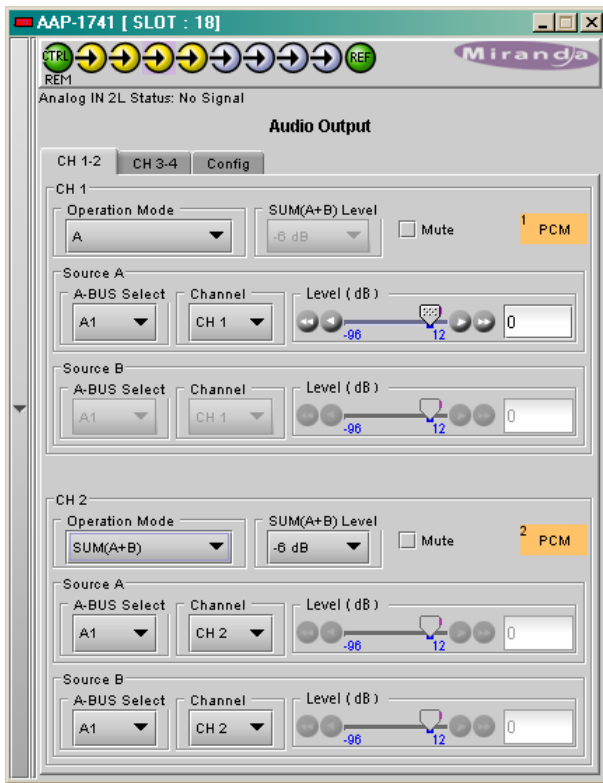

Mix (see CH 3 in the figure on the right)

Two sources are selected using the Source A and Source B ABUS Select and Channel pulldowns. The two sources are mixed, with the level of each source adjusted using its slider or data entry box.

- The ABUS select options are:
 - **V** selects one of the 16 channels from the video card.
 - **A1** selects one of the 16 channels from an audio card. A1 is always Local, Slave 1 or Master
 - **A2** selects one of the 16 channels from an audio card. A2 is always Slave2 or Slave.
- The contribution of each of the sources to the mix is adjusted using its Level slider or direct keyboard entry into the data box, over a range from -96 to +12 dB.

NOTE: If you attempt to mix two different audio types to an output, only the Source A signal will be routed to this output and the Source A audio type will be displayed. The Source B signal will be ignored.

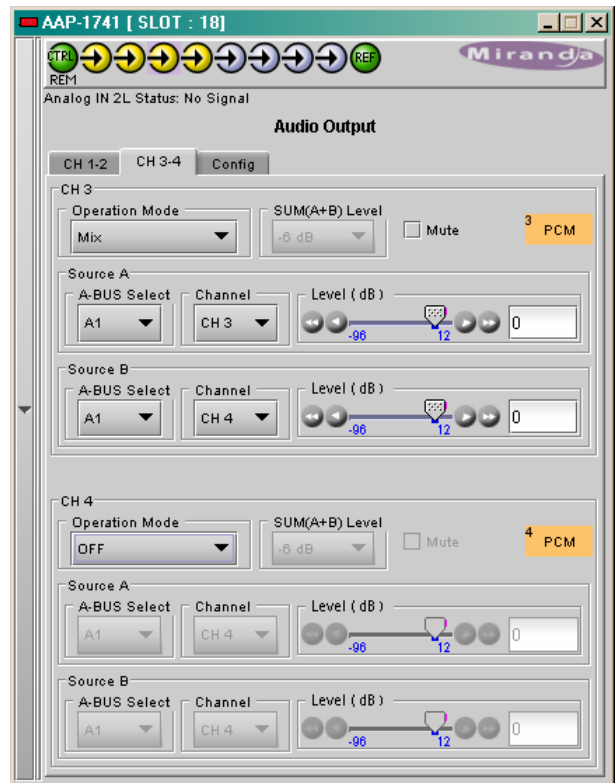

OFF (See CH 4 in the figure to the right)

The output is muted.

3.3.3.2 Audio Output - Config tab:

The **Output 0 dBFS** pulldown box sets the analog outputs conversion ratio: the default value for 0 dBFS will be +24 dBu, and it can be adjusted down to 0 dBu.



3.3.4 UP/DOWN MIX

3.3.4.1 UP/DOWN MIX – Config tab

With the UP/DOWN MIX option enabled (see section 3.3.11), the **UP/DOWN MIX mode** radio buttons offer the choice between

- OFF
- UPMIX
- DOWNMIX

Once the choice is made, the appropriate tab will be enabled (its text will not be greyed-out), and can be accessed to configure the mix process.

This process is part of the input processor, refer to the block diagram.

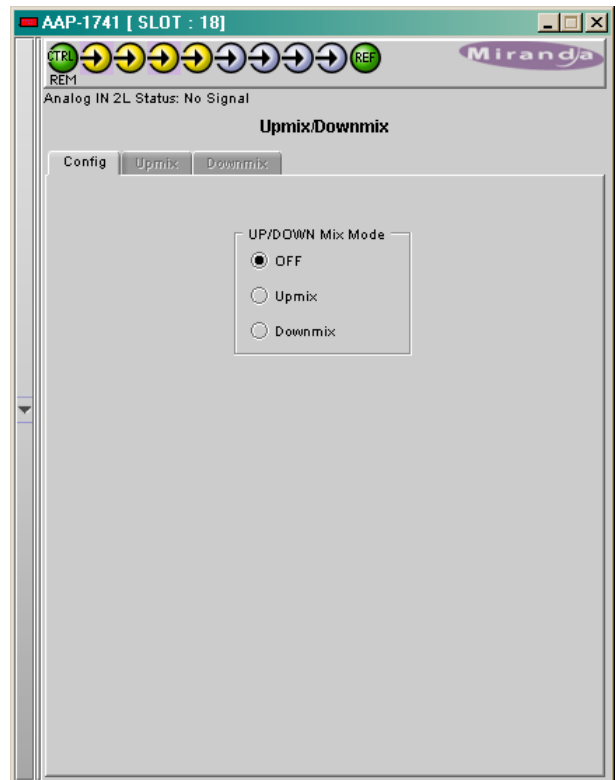

3.3.4.2 UP/DOWN-MIX – UP-MIX *tab*:

This feature is used to create from a stereo source a multi channel compatible audio signal with up to six channels: Left, Right, Center, Left Surround, Right Surround and the Low Frequency Effect.

The selection of the stereo source is done with the two pull down boxes **Left Source** and **Right Source**.

The pull down box Type offers three different standard mixes and a custom position. The proposed standard mixes are named **Speech**, **Music** and **Movie**. For each standard, an **Effect** slider allows to keep the **Effect** very light, with the slider down to 0, or emphasized when going to 10.

The **Custom** position leaves all the settings available to the user for specific needs.

3.3.4.3 UP/DOWN-MIX – DOWN-MIX *tab*:

This tab provides resources to control the downmix of a “5.1 channel” surround-sound audio signal into an LtRt or LoRo stereo pair. The 5.1 terminology refers to six discrete audio channels, with the low-frequency channel of limited bandwidth designated as the .1 channel.

The default source channels are CH9 to CH14, an input **Shuffler** allows any combination of the input channels. The **Down-mix** stereo pair is mapped into audio channels 15 and 16.

The mixing configuration is defined with pull down boxes.

Mode:

- OFF disables the audio down-mix. The audio channels 15 and 16 pass through unchanged.
- LtRt: enables the down-mix of 5.1 channels into an LtRt matrix surround encoded stereo pair. The input signals on channels 15 and 16 are discarded.
- LoRo: enables the down-mix of 5.1 channels into an LoRo stereo pair, which is a conventional stereo signal. The input signals on channels 15 and 16 are discarded.

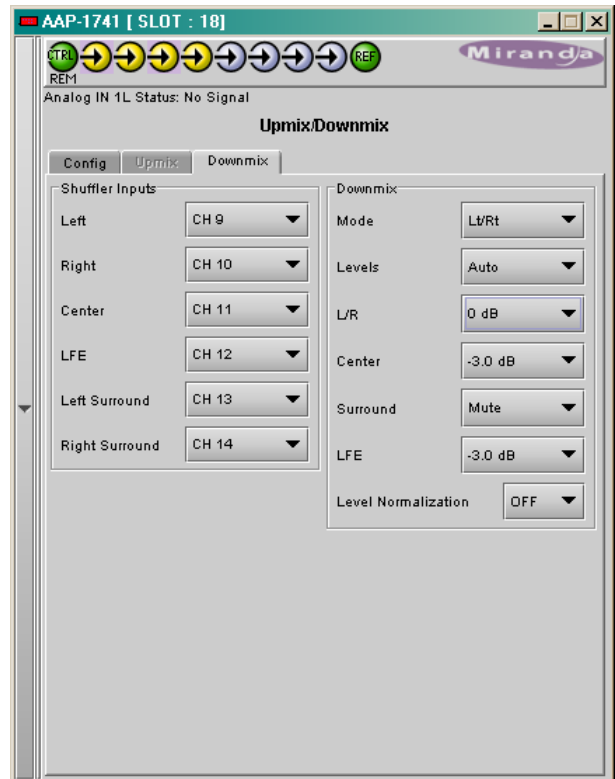
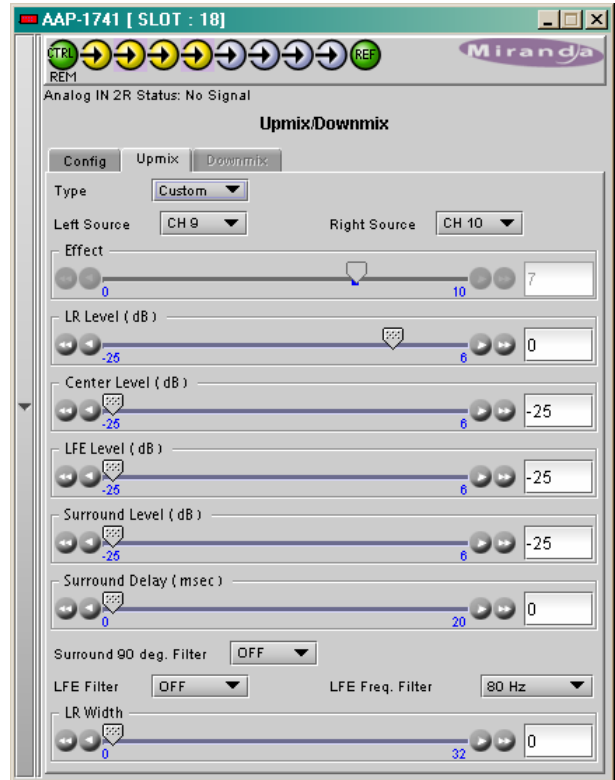

Type:

- Auto the down-mix levels are taken from the Dolby metadata attached to the selected discrete channels. If no Dolby metadata is present, down-mix levels default to those currently set by the user in the L/R, Center, Surround and LFE pull-downs.
- Manual the user sets the down-mix levels via the L/R, Center, Surround and LFE pull-down boxes: the default values are:
 - L/R 0 dB
 - Center -3 dB
 - Surround -3 dB
 - LFE cut

Select "**Level Normalization**" ON to ensure a constant level of the down-mix output into the audio channels 15 and 16.

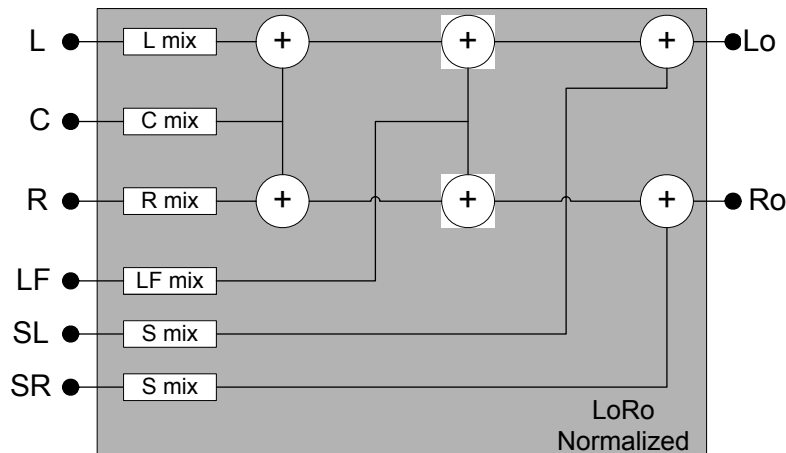
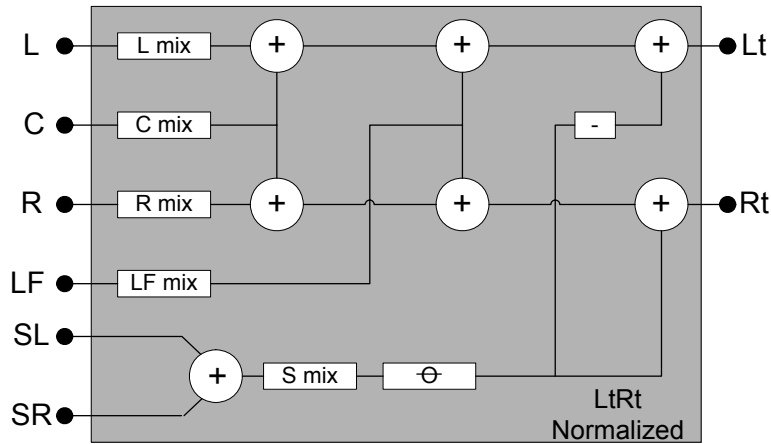

3.3.5 Audio Type

This Windows indicates the audio type of each channel at the input of the card, and at the ABUS inputs and outputs.

Detected audio types can be PCM, AC3 (Dolby Digital), Dolby E or NPCM (other non-PCM).

Card Input Channels

For Channels 1 to 4, which are the card analog inputs, the indicators display always PCM.

Input Channels (Ext) – Abus IN

This section corresponds to the ABUS In channels, originating from the embedded audio channels demuxed in the video card.

- Only channels 1-8 or 9-16 are input to the processing; the choice is made in the **Audio Processing - CONFIG** tab.

Embedded Channels (Video)

Indicate the type of the 16 post input processing channels coming from the video card via ABUS Out.

A-BUS Channels (Slave1)

Indicate the type of the 16 post input processing channels coming via ABUS Out from the audio card Slave 1, or Master in a two audio card system.

A-BUS Channels (Slave2)

Indicate the type of the 16 post input processing channels coming via ABUS Out from the audio card Slave 2.

Card Output Channels

The channels 1 to 4 are the card analog outputs.



3.3.6 RALM tab:

This Remote Audio Level Meters feature allows distant supervision of the audio levels present at the four outputs of the AAP-1741.

3.3.6.1 RALM Connections tab

CH1&2, CH3&4 – each radio button turns the player ON or OFF for the pair of channels.

Reset Counter – reset the overload counter to zero. The counters are located on top of each meter. See Overload Cursor in the Meter Ballistics section for more information.

RALM Remote Control – To limit the data flow required by the meters, each pair of meters can be turned ON and OFF independently. Each checkbox controls the transmission for 2 channels of RALM data to the iControl server.

The **Speed** pull-down affects the refresh rate, the default value is slow.

3.3.6.2 RALM – Meter Ballistics Config tab

Type – select a type of meter from the pull-down list. When using analog input on a digital peak meter, the correspondence between the input in dBu and 0 dB Full Scale is given in the **Audio Processing – Config** tab.

The zero of the analog VU Meter is fixed at -20 dBFS. The zero of the analog Peak meter is fixed at -24 dBFS. Refer to the 0 dBFS value to get a dBu value.

When using a digital input on an analog peak meter, the test position is fixed at -24 dBFS. The 0 VU meter is fixed at -20 dBFS.

Upper Zone Limits – select the crossover level between the upper and middle zones of the meter (the range of values shown in the pull-down list depends on the meter type). The zone limits are in dBu for analog meters and in dBFS for digital meters

Lower Zone Limits – select the crossover level between the middle and lower zones of the meter (the range of values shown in the pull-down list depends on the meter type). The zone limits are in dBu for analog meters and in dBFS for digital meters

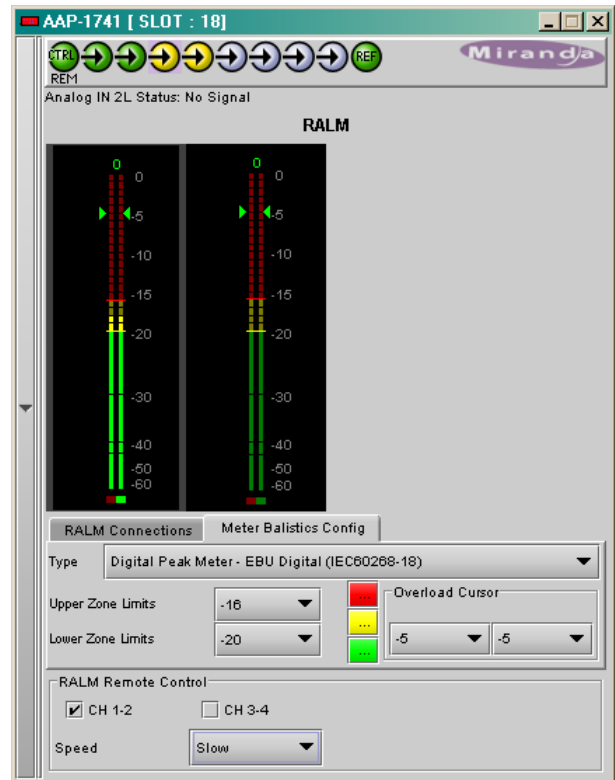
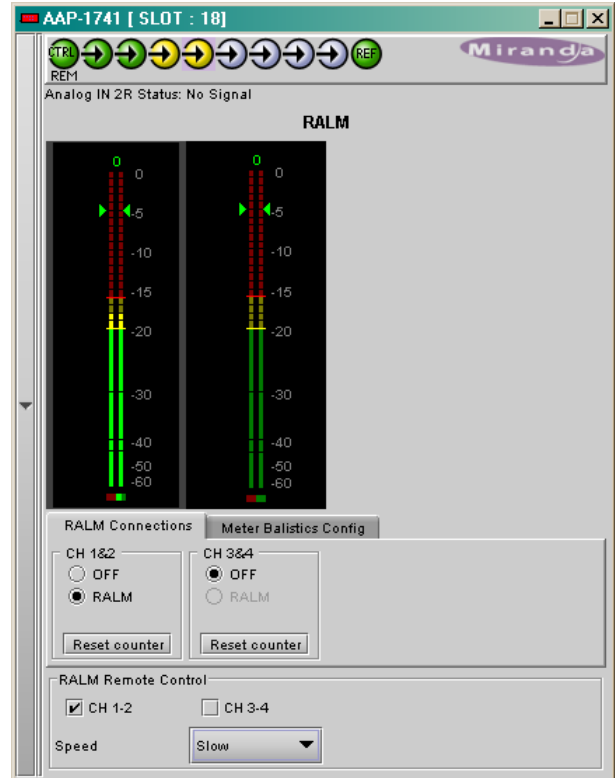

Color samples – the three samples show the currently-selected color for the upper, middle and lower zones of the meter.

Overload Counter - The overload cursor appears on the meter as an arrowhead in the meter scale. The two pulldown boxes set the position of the overload cursor on the left and right meters. If the audio level on that channel goes above the cursor, the Overload Counter at the top of the meter is incremented. The **Reset Counter** box is available on the **RALM - Connections** tab.

Phasemeter – this is a small meter that represents the phase correlation factor. Nominal position is in the center, which indicates also the absence of signal. The red side, up to the left end of the meter indicates the level of phase opposition and the green side, up to the right end indicates the level of phase amplitude.

3.3.7 A-BUS

The AAP-1741 can be used stand alone or as a companion to provide additional audio channels for other Densité cards. The A-BUS (audio bus) links the AAP-1741 to the other cards and is used to configure the system and to display the presence of other installed cards.

A-BUS Config:

Select whether the A-BUS is to be disabled, and whether this AAP-1741 is Master, Slave 1 or Slave 2 in the A-BUS configuration.

- **Not connected to Audio Bus** – when the A-BUS is disabled, it is not possible to detect other attached cards in the system.
- **Slave 1 of Video Card** – used for a two-card system when the other card is a video processor.
- **Slave 1 of Video Card, Slave 2 is present** – used for a three-card system, with a video processor and another audio processor configured as Slave2.
- **Slave 2 of Video Card, Slave 1 is present** – used for a three-card system, with a video processor and another audio processor configured as Slave1.
- **Master** – the card is standalone, or used as a master for another audio processor configured as Slave. This mode is not available when a video card is attached to the A-BUS.
- **Slave of Audio Master Card** – used for a two-card system when the other card is a audio processor configured as Master.

Status:

- **V Presence** – turns green to monitor the presence of a video card in the A-BUS configuration.
- **A2 Presence** - monitors the presence of another audio card in the A-BUS configuration. The icon is labeled A2 if this card is Slave1, and is labeled A1 if this card is Slave2.

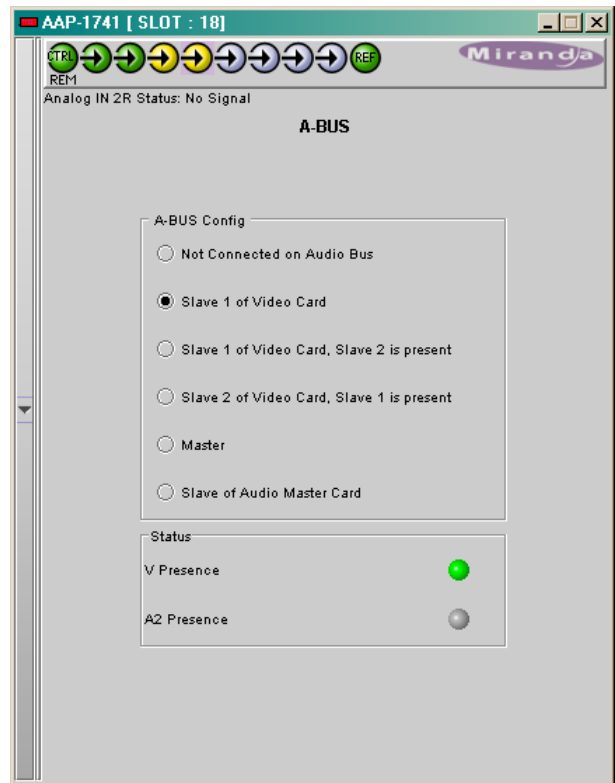

3.3.8 Reference Input

Reference – Desired:

Use a radio button to select a reference signal for the AAP-1741. The reference sources are placed by order of priority where ABUS has the highest priority. The absence of the selected reference is an error condition.

- Select Auto in the header bar to automatically select the highest-priority reference present and valid.

Reference – Current:

This section indicates the current reference used by the AAP-1741. Many reference sources may be present and valid. When a valid reference is not present, the AAP-1741 reverts to Free-Run mode (this is an error condition).

Reference – Presence:

Five dedicated presence indicators display the valid reference sources: one for a reference card REF-17xx in slot 10 of the Densité frame, one for a reference card REF-1xxx in slot 20, and one for a valid AES1 input signal.

The URS is a single signal that is capable of distributing to all cards in a Densité frame a frequency reference and frame alignment references for all video and audio signals.

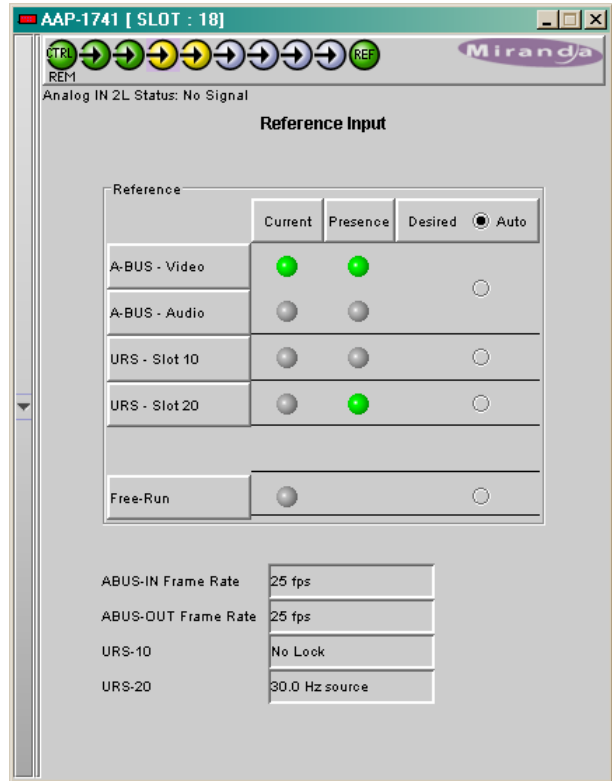

3.3.9 Rear Type

This tab shows the type of the rear panel: single or dual width.

AAP-1741-I-SRP: 4 analog inputs

AAP-1741-O-SRP: 4 analog outputs

AAP-1741-SRP: 2 analog inputs
and 2 analog outputs

AAP-1741-DRP: 4 analog inputs
and 4 analog outputs

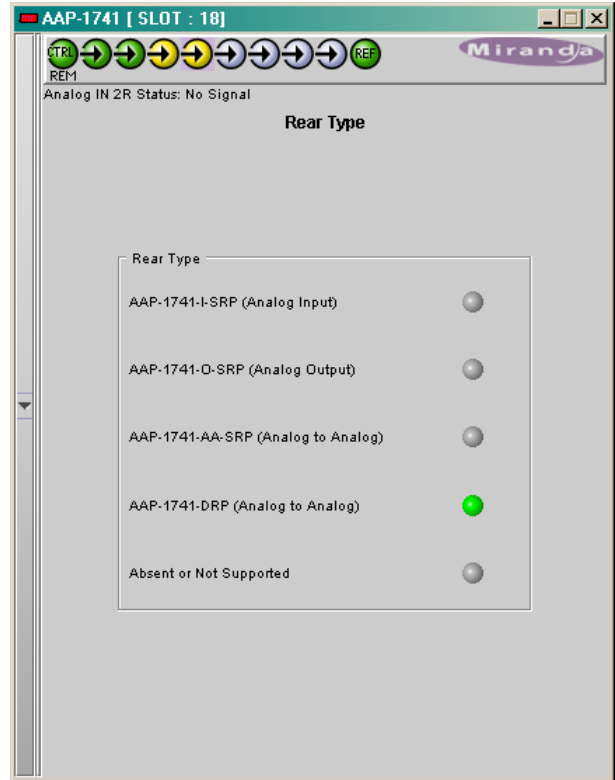

3.3.10 Factory / Presets

Load Factory - The **Factory** profile is a read-only set of factory-selected values that can be used to return the AAP-1741 to a standard operating condition without affecting the **User Presets**.

- The AAP-1741 Menu in section 3.2.2 indicates the default values for all parameters

User Presets - The five **User Presets** are read-write data registers that allow you to save the contents of the Current state of the AAP-1741 for later recall.

Select any one of the five presets using the pull-down list. The name of the currently-selected **User Preset** is shown on the name bar.

- Click **Load** to load the contents of the selected **User Preset** into the AAP-1741. All parameter settings and values will be replaced by the contents of the selected **User Preset**.
- Click **Save** to store the current parameter settings and values from the AAP-1741 into the selected **User Preset**. The existing contents of the preset will be overwritten.

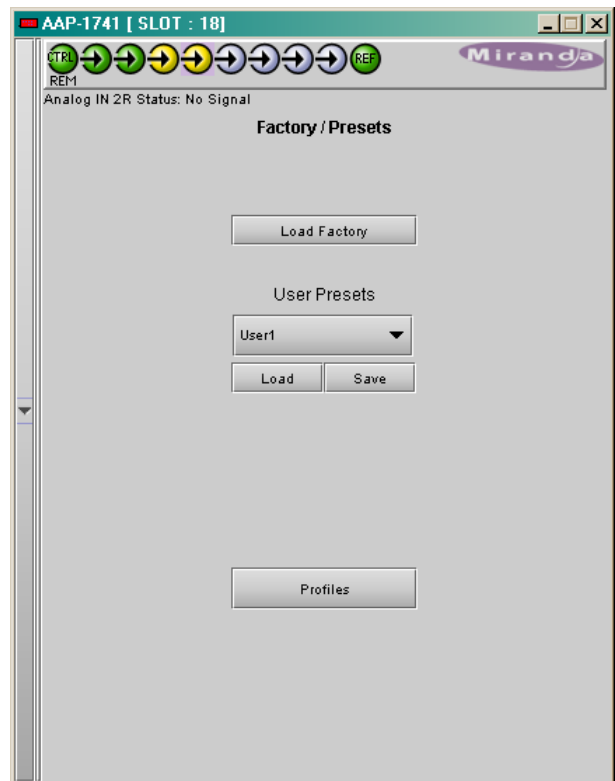

3.3.10.1 Profiles

Click the Profiles button at the bottom of the Factory/Presets panel to open a window allowing parameter settings to be copied from this AAP-1741 card to other AAP-1741 cards.

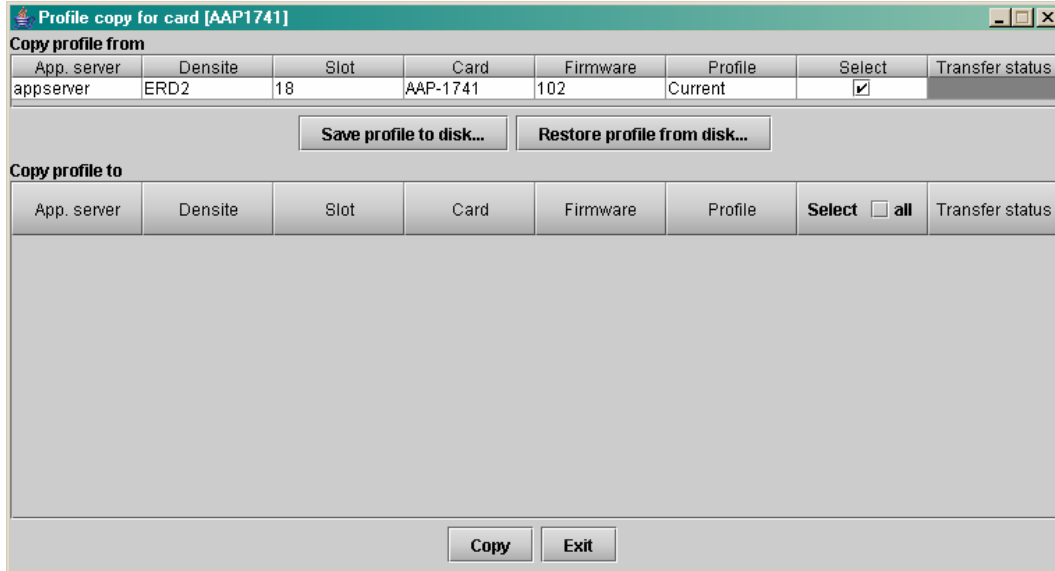

- The **Copy Profile From** line shows the current AAP-1741.
- The **Copy Profile To** table shows all other AAP-1741 cards available in the local iControl environment

Click in the individual Select boxes to select one or more destination AAP-1741 cards, or click Select All to select all of them at once. Those noted as not available (N/A) in the Transfer Status column cannot be selected.

Click on the Profile entry in the source AAP-1741 line to see a pull-down listing the Current profile and all 5 **User Presets**. Click on one to select it as the source profile

Click Copy to copy the contents of the selected profile into the same-named profile on the destination AAP-1741 cards.

3.3.11 Options

Two options are available for the AAP-1741:

- **UP/DOWN MIXING** option (AAP-1741-OPT-MIX)
- **DYNAMIC PROCESSING** option (AAP-1741-OPT-DYN)

Activate either option on the AAP-1741 card by entering the activation **key** into the **Enter Key** data box in its tab, and clicking the **Enable Option** button.

- The current status of the option is shown in the status box below the Enter Key data box.

See the text message at the top of the tab for information about purchasing an option and obtaining the activation key.

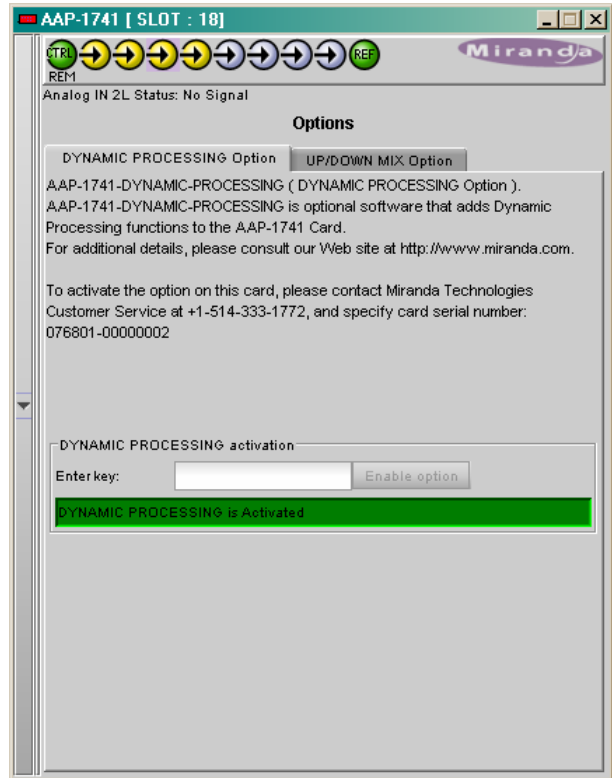

3.3.12 Alarm Configuration

Selecting the **Alarm config** tab opens a separate window for error status reporting. The alarm Configuration Panel shows all measured parameters and offers the following options for each:

Choose an alarm **Name**, use the pull-down box in the **Overall alarm** column to select the level associated to this alarm: **Disabled**, **Minor**, **Major** or **Critical**.

Check Log events to enable logging. The result is stored in a database managed with GSM in iControl Navigator.

In the bottom of the column **Status/Name**, the **Card LED** color follows the status of the physical card LED, as defined in the front panel menu Configure Alarm (page 21).

The overall Status is reflected by the color of the indicator attached to the card in iControl Navigator. It is also displayed in the upper left corner of the iControl Interface of the AAP-1741.

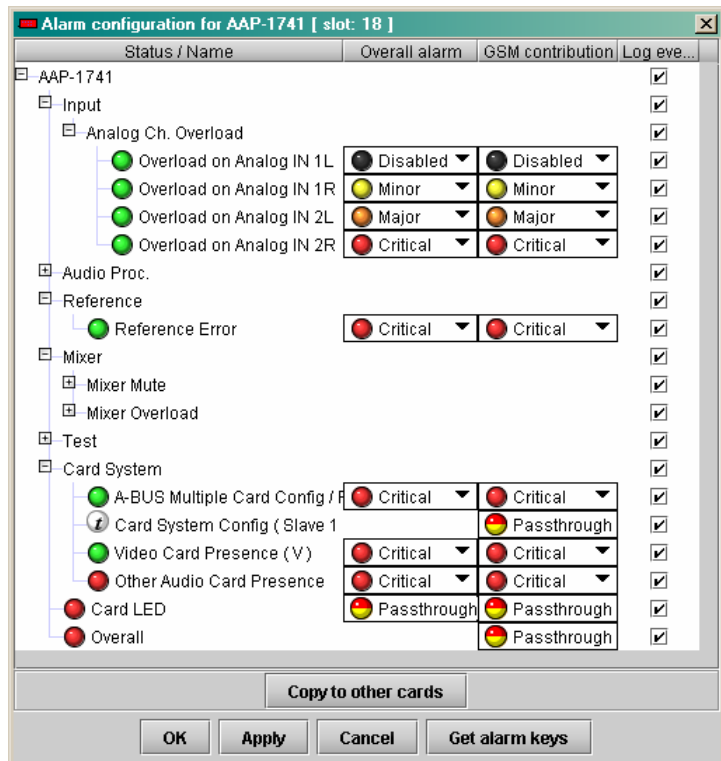

GSM is a dynamic register of all the system alarms, and is also an alarm provider for external applications.

3.3.13 Info

The Info panel provides the user information about the AAP--1741.

The boxes titled Label, Short Label, Source ID and Comments are editable – the user can enter their own information.

The Advanced button displays the name of the server within the iControl system, the frame in which it is installed, the slot occupied by the card and it's ID (75 for AAP-1741).

The Remote System Administration button at the bottom of the window opens a data entry box titled Joining Locators, in which the ADD option opens a dialog box in which the user can identify the Locator by its URL.



4 Specifications

Analog Inputs (4)

Signal	analog audio
Input impedance	> 10 k Ω
Maximum level	+24 dBu

Analog Outputs (4)

Signal	balanced analog audio
Output impedance	50 Ω
Max. Level	+24 dBu
Min. Load	600 Ω

Processing

Sampling frequency	48 kHz
Quantization	24 bits

Analog to Analog

Freq. response	\pm 0.3 dB (20 Hz to 20 kHz)
SNR	114 dB (A weighted)
THD+N	-95 dB (20 Hz to 10 kHz)
Crosstalk	-100 dB (20 Hz to 20 kHz)
Group delay	1.21 ms

Miscellaneous

Tone generator	1 kHz sine wave interrupted on left channel (250 ms / 3 s) EBU R49
Signal presence threshold	from -72 to -48 dBFS (6 dB steps)
No signal delay	from 0 to 255 s (1 s steps)
Fixed delay	0 to 2.4 s Steps: ms (coarse) & sample (fine)
Tracking delay	0 to 8 video frames

Power

AAP-1741-xxxxx-SRP:	< 5 W
AAP-1741-xxxxx-DRP:	< 10 W