

MC²
AUDIO

E Series

Lightweight Touring Power Amplifiers

E100

Operating Instructions

MC²
AUDIO

www.mc2-audio.co.uk
Tel. +44 (0)1404 44633 Fax. +44(0)1404 44660
MC² AUDIO | Units 6-8 Kingsgate | Heathpark Industrial Estate
Honiton | Devon | England | EX14 1YG

CONTENTS

DECLARATION OF CONFORMITY.....	4
THANKS.....	5
INTRODUCTION.....	5
IMPORTANT SAFETY INSTRUCTIONS	6
INSTRUCTIONS DE SECURITE IMPORTANTES	7
Installing Your Amplifier: Electrical Considerations.....	8
Installing Your Amplifier: Mechanical Considerations.....	9
Installing Your Amplifier: RF Emissions	9
About Your Amplifier: Dynamic Amplifier Performance Measurements	10
Connecting To Your Amplifier: Inputs.....	11
Connecting To Your Amplifier: Speaker Outputs.....	12
Connecting To Your Amplifier: Bridged (Mono) Operation.....	13
Operating Your Amplifier: Front Panel Controls and Indicators.....	14
Operating Your Amplifier: Notes and Switching On	15
Operating Your Amplifier: Rear Panel Sockets and Switches	16
Looking After Your Amplifier: Maintenance	17
Looking After Your Amplifier: Warranty	17
Changing the Gain of Your Amplifier: Internal Adjustments!.....	18
Performance Of Your Amplifier: Specifications	19

MC² AUDIO



DECLARATION OF CONFORMITY

We, the manufacturer:

**MC² Audio,
Units 6-8 Kingsgate
Heathpark Industrial Estate
Honiton, Devon
England
EX14 1YG**

acknowledge our responsibility that the following products:

Kind of equipment: Audio amplifier
Commodity Code: 8518408990
Type Designation: T500, T1000, T1500, T2000, T3500, T4-250
Ti500, Ti1000, Ti1500, Ti2000, Ti3500, Ti4-250
E15, E25, E45, E90, E100, E475
S800, S1400
and all OEM variants of these models

are manufactured:

in accordance with EMC Directive 2004/108/EC,
in compliance with the following norm(s) or document(s):
Technical Regulations: EN55103-1:1996, EN55103-2:1996

and

in accordance with the Low Voltage Directive 2006/95/EC,
in compliance with the following norm(s) or document(s):
Technical Regulations: EN/IEC60065:2002 7th Edition

Signed:

Name: Alex Cooper
Position: Research and Development Manager
Date: January 2012

MC² AUDIO

THANKS

Thank you for choosing an E Series amplifier for your application. Please spend a little time reading through this manual, so that you obtain the best possible performance from the unit and become familiar with its operating requirements.

All MC² products are carefully designed and engineered for cutting-edge performance and world-class reliability. If you would like further information about this or any other MC² product, please contact us.

We wish you many years of service from this amplifier and look forward to hearing from you in the near future.



INTRODUCTION

The most powerful four channel amplifier MC² has ever made, the E100 has been designed to meet demands for higher power and increased efficiency, whilst still maintaining the renowned sonic qualities and unsurpassed reliability associated with all our amplifiers.

Proprietary class-D technology with a dual feedback loop system gives exceptional transient response and a resonant switch mode power supply with a large reservoir gives extremely high peak power without any “bass sag”.

Newly designed limiters, linked to the output current monitors and power supply, keep mains input and output currents within a safe operating area at all times, whilst maintaining transparent sonic performance.

Running cool in even the most difficult conditions, the E100 can deliver over 2500W into 4 ohms with all channels driven, and a massive 2 x 7400W bridged (4R), with outstanding distortion and noise figures right up to maximum output.

The amplifier, of course, includes full DC, VHF, thermal and short circuit protection to ensure continuous trouble-free service.

IMPORTANT SAFETY INSTRUCTIONS

CAUTION: RISK OF ELECTRIC SHOCK.
DO NOT OPEN

The lightning flash with arrowhead symbol within an equilateral triangle is intended to alert the user to the presence of uninsulated "dangerous voltage" within the product's enclosure that may be of sufficient magnitude to constitute a risk of electric shock to persons.



The exclamation point within an equilateral triangle is intended to alert the user of important operating and maintenance (servicing) instructions in the literature accompanying the appliance.

WARNING: Apparatus with CLASS I construction shall be connected to a MAINS socket outlet with a protective earthing connection.

WARNING: To prevent injury, this apparatus must be securely attached to the rack in accordance with the installation instructions.

Read these instructions.

Keep these instructions.

Heed all warnings.

Follow all instructions.

Do not use this apparatus near water.

Clean only with a dry cloth.

Do not block any ventilation openings, install in accordance with the manufacturer's instructions.

Do not install near any heat sources, such as radiators, heat registers, stoves or other apparatus (including amplifiers) that produce heat.

Protect the power cord from being walked on or pinched particularly at plugs, convenience receptacles and the point where they exit from the apparatus.

The mains circuit breaker shall remain readily accessible.

Only use attachments/accessories specified by the manufacturer.

Use only with the cart, tripod, bracket or table specified by the manufacturer, or sold with the apparatus. When a cart is used, use caution when moving the cart/apparatus combination to avoid injury from a tip over.

Disconnect this apparatus during lightning storms or when unused for a long period of time.

Refer all servicing to qualified service personnel. Servicing is required when the apparatus has been damaged in any way, such as if the power-supply cord or plug is damaged, liquid has been spilled or objects have fallen into the apparatus, the apparatus has been exposed to rain or moisture, does not operate normally, or has been dropped.

Do not expose this equipment to dripping or splashing and ensure that no objects filled with liquids, such as vases, are placed on the equipment.

To completely disconnect this equipment from the AC mains, disconnect the power cord from the mains circuit breaker.

Where the amplifier is mounted in a rack and permanently connected to the mains, then the rack should be installed with a readily accessible connector or an ALL POLE circuit breaker with 3mm breaking distances.

This unit is fitted with a 3-wire power cord. For safety reasons, THE EARTH LEAD SHOULD NOT BE DISCONNECTED IN ANY CIRCUMSTANCE.

The cooling fans suck cool air in through the front and blow hot air out at the rear of the unit through the ventilating grills. The front and rear of the amplifier should have free exposure to the air (i.e. in a rack leave the front and rear doors off), with 2cm air gap at the sides and top. IF AIR IS NOT ALLOWED TO ESCAPE FROM THE REAR, OVER-HEATING WILL OCCUR. Take care when mounting other equipment in the same rack.

The mains switch on the amplifiers only switches one pole of the mains supply, therefore for units with a detachable cord to be fully disconnected from the mains, the mains disconnect device (ie mains plug or mains coupler) should remain readily operable. For units with a fixed mains lead the external all pole circuit breaker with 3mm breaking distances is the disconnect device and therefore the installation of the amplifier shall be carried out in accordance with all the applicable installation rules.

INSTRUCTIONS DE SECURITE IMPORTANTES

**ATTENTION: RISQUE DE CHOC ELECTRIQUE.
NE PAS OUVRIR**

Le symbole représentant un éclair fléché dans un triangle équilatéral a pour but d'alerter l'utilisateur de la présence d'une "tension dangereuse" non isolée à l'intérieur du boîtier, pouvant être d'une force suffisante pour constituer un risque d'électrocution.



Le point d'exclamation dans un triangle équilatéral a pour but d'alerter l'utilisateur de la présence d'instructions importantes concernant le fonctionnement et la maintenance, dans la documentation qui accompagne l'appareil.

ATTENTION: Appareils de construction de CLASSE I doit être raccordé au réseau électrique via une prise de courant reliée à la terre.

ATTENTION: Pour éviter toute blessure, cet appareil doit être solidement fixé à la torture, conformément aux instructions d'installation.

Lisez ces instructions.

Gardez ces instructions.

Faites attention à tous les avertissements.

Suivez toutes les instructions.

N'utilisez pas cet appareil près de l'eau.

Faites le ménage seulement avec un tissu sec.

Ne bloquez pas d'ouvertures de ventilation, installez conformément aux instructions du fabricant.

N'installez près d'aucunes sources de chaleur, comme les radiateurs, les registres de chaleur, les cuisinières ou d'autre appareil (en incluant des amplificateurs) qui produisent la chaleur.

Protégez la corde de pouvoir d'être marché sur ou pincé particulièrement aux prises de courant, les réceptacles d'avantage et la pinte où ils sortent de l'appareil.

Le disjoncteur de conduite principale restera sans hésiter accessible.

Utilisez seulement des attachements/accessoires spécifiés par le fabricant.

Utilisez seulement avec le chariot, le trépied, la parenthèse ou la table spécifiée par le fabricant, ou vendu avec l'appareil. Quand un chariot est utilisé, utilisez la prudence en déplaçant la combinaison de chariot/appareil pour éviter la blessure d'un bout.

Débranchez cet appareil pendant les tempêtes de foudre ou quand neuf pendant un long terme de temps.

Renvoyez tout l'entretien au personnel de service qualifié. L'entretien est exigé quand l'appareil a été nui de toute façon, comme si la corde de pouvoir provision ou la prise de courant sont nuis, le liquide a été déversé ou les objets sont tombés dans l'appareil,

l'appareil a été exposé pour pleuvoir ou l'humidité, n'opère pas normalement, ou a été baissé.

N'exposez pas cet équipement au fait de tomber goutte à goutte ou au fait d'éclabousser et garantisiez qu'aucun objet rempli des liquides, comme les vases, n'est placé sur l'équipement.

Pour complètement débrancher cet équipement de la conduite principale de courant alternatif, débranchez la corde de pouvoir du disjoncteur de conduite principale.

Où l'amplificateur est monté dans un égouttoir et en permanence raccordé à la conduite principale, alors l'égouttoir devrait être installé avec un connecteur sans hésiter accessible ou TOUT le disjoncteur de PÔLE avec 3 millimètres cassant des distances.

Cette unité est correspondue avec une corde de pouvoir de 3 fils. Pour les raisons de sécurité, L'AVANCE DE TERRE NE DEVRAIT ÊTRE DÉBRANCHÉE DANS AUCUNE CIRCONSTANCE.

Les ventilateurs engloutissent l'air frais par le front et soufflent l'air chaud à l'arrière de l'unité par les grils aérants. Le front et l'arrière de l'amplificateur devraient avoir l'exposition libre à l'air (c'est-à-dire dans un égouttoir omettent les portes de devant et arrière), avec le trou aérien de 2 centimètres aux côtés et au haut. Si on NE PERMET PAS QUE D'AIR S'ÉCHAPPE DE L'ARRIÈRE, LE FAIT DE SURCHAUFFER SE PRODUIRA. Faites attention en montant d'autre équipement dans le même égouttoir.

L'interrupteur principal sur les amplificateurs ne coupe qu'un pôle de l'alimentation secteur. le cordon IEC permettra de déconnecter l'appareil de l'alimentation secteur, pour cette raison l'accès à ces fiches (fiche mâle ou femelle) doit être facilités.

Pour les appareils avec un câble d'alimentation fixe sans fiche secteur, le dispositif de coupure omnipolaire ayant une distance d'ouverture de contact d'au moins 3mm, sera le dispositif permettant la déconnexion complète de l'appareil.

Pour cette raison l'installation et le raccordement de l'amplificateur devra ce faire conformément au réglementation en vigueur.

Installing Your Amplifier: Electrical Considerations

The amplifier has been manufactured to comply with your local power supply requirements, but before connecting the unit to the supply, ensure that the voltage (printed on the rear panel) is correct.

The amplifier is fitted with either a 100/120V or 220/240V tapped transformer according to customer requirements.

Make sure power outlets conform to the power requirements listed on the back of the unit. Damage caused by connecting to improper AC voltage is not covered by the warranty.

SAFETY WARNING

Where a MAINS plug or appliance coupler is used as the disconnect device, it should remain readily operable.

Where the amplifier is mounted in a rack and permanently connected to the mains, then the rack should be installed with a readily accessible connector or an ALL POLE circuit breaker with 3mm breaking distances.

This unit is fitted with a 3-wire power cord.

For safety reasons,

THE EARTH LEAD SHOULD NOT BE DISCONNECTED IN ANY CIRCUMSTANCE.

If ground loops are encountered consult the section on connecting your amplifier on page

Error! Bookmark not defined..

The wiring colours are:

230V AREAS: EARTH = GREEN AND YELLOW
NEUTRAL = BLUE
LIVE = BROWN

120V AREAS: EARTH = GREEN
NEUTRAL = WHITE
LIVE = BLACK

DO NOT USE THE UNIT IF THE ELECTRICAL POWER CORD IS FRAYED OR BROKEN. The power supply cords should be routed so that they are not likely to be walked on or pinched by items placed upon or against them, paying particular attention to cords and plugs and the point where they exit from the appliance.

ALWAYS OPERATE THE UNIT WITH THE AC GROUND WIRE CONNECTED TO THE ELECTRICAL SYSTEM GROUND. Precautions should be taken so that the means of grounding of a piece of equipment is not defeated.

DO NOT REMOVE THE LID. Removing the lid will expose you to potentially dangerous voltages. There are no user serviceable parts inside.

ESD strikes to the unit's front panel that are in excess of 4000 volts may cause disturbance to the status LEDs on the unit. This will not affect audio performance and will be corrected on the next power up cycle.

Installing Your Amplifier: Mechanical Considerations

To ensure that this equipment performs to specification, it should be mounted in a suitable rack or enclosure as described below. Like all high power amplifiers, it should be kept away from other equipment which is sensitive to magnetic fields. Also, this amplifier may suffer a substantial reduction in performance if it is subjected to, or mounted close to equipment which radiates high RF fields.

Warning: To prevent injury, this apparatus must be securely attached to the rack in accordance with the installation instructions

When mounting the amplifier in a rack or enclosure:

Be aware that...

THE FRONT PANEL IS NOT CAPABLE OF SUPPORTING THE UNIT ON ITS OWN.

Make sure that the rear of the unit is adequately supported. The brackets which are supplied fit standard 19 inch (483mm) rack mounting systems.

ENSURE THERE IS ADEQUATE VENTILATION.

The cooling fans suck cool air in through the front and blow hot air out at the rear of the unit through the ventilating grills. The front and rear of the amplifier should have free exposure to the air (i.e. in a rack leave the front & rear doors off), with 2cm air gap at the sides.

IF AIR IS NOT ALLOWED TO ESCAPE FROM THE REAR, OVER-HEATING WILL OCCUR.

Take care when mounting other equipment in the same rack.

Make sure that the rack unit has a separate earth connection (technical earth).

Please also see the notes regarding maintenance on page 17.

Installing Your Amplifier: RF Emissions

The high frequency resonant converters in the E Series amplifiers have been designed to have very low radio frequency (RF) emissions; however even these low level emissions can cause interference with other equipment.

In order for this to be minimised, the amplifier should be mounted in a metal rack enclosure, which should have a separate (technical) Earth. Alternatively a separate earth should be attached to the amplifier at the rear rack mounting bracket.

About Your Amplifier: Dynamic Amplifier Performance Measurements

The E100 is the very latest example of a 'dynamic amplifier'. This new 'breed' of power amplifiers provide very high peak power levels in a much smaller, and lighter, package than previously possible with conventional amplifiers.

They are designed specifically for today's high power audio installations, which use multiple speakers with electronic crossovers or speaker controllers. These systems can handle very high transient signals that far exceed their RMS power rating. The E Series amplifiers have been designed to match this requirement and can deliver huge levels of power for short durations.

In order to protect themselves and the loudspeakers that they are driving, continuous signals such as sine waves, are automatically detected and reduced (ramped down) to a safe level.

When trying to **measure the power output** however, continuous signals will give totally incorrect results. A dynamic signal, such as a tone burst, should be used and the levels measured by monitoring the waveform on an oscilloscope. The power envelope can then be accurately measured.

Our power output figures are measured using signals with known Crest Factors and are quoted at the rear of this manual and on our website.

Please refer to the technical area of our website for further information.

Connecting To Your Amplifier: Inputs

The inputs are made via 3-pin XLR connectors, which are electronically balanced and should be connected via a high grade twin core screened cable, as follows:

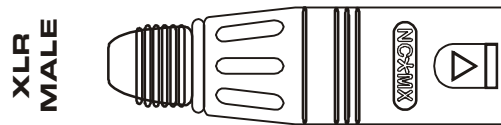

PIN1: Screen (see note)
PIN2: Hot (signal +)
PIN3: Cold (signal -)

The amplifier is designed to operate with fully balanced equipment and ground loops or loss of performance may be experienced if connected to unbalanced sources. If it is unavoidable however, the following wiring should be used. The cable should still be twin core plus screen.

PIN1: Screen - connected to the chassis of the unbalanced equipment - or left disconnected at the unbalanced end.
PIN2: Hot (signal +)
PIN3: Cold (ground 0V)

NOTE: This amplifier is wired to the latest industry recommendations. PIN1 is connected directly to the chassis/mains earth. If ground loops (mains hum) are encountered remove the screen connection from the other end of the cable and leave it open circuit. If problems persist, consult your dealer/supplier.

DO NOT TAMPER WITH OR ALTER ANY GROUND (EARTH) CONNECTIONS INSIDE THE AMPLIFIER.

For bridged operation input should be made to channel A (or C) only and the rear panel switch set for bridged mode for the appropriate pair of channels.

Connecting To Your Amplifier: Speaker Outputs

The speaker outputs are via Neutrik Speakon connectors. 2 pole (NL2FC) or 4 pole (NL4FC) connectors can be used.

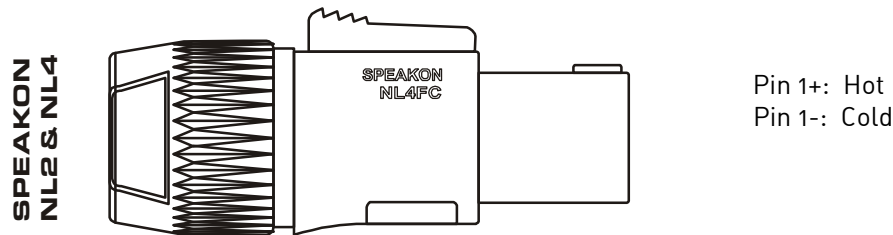

Additionally Channel A Speakon connector carries Channel B output on Pins +2 & -2 to allow easy bi-amping or bridged operation using a single NL4 connector. Similarly, Channel C's Speakon connector also carries Channel D output.

Output Connector A

Pin 2+: Hot Ch. B
Pin 2-: Cold Ch. B

Output Connector C

Pin 2+: Hot Ch. D
Pin 2-: Cold Ch. D

For bi-amped operation, connect as above.

There must be no shared connections between channels.

Negative output terminals must not be joined together as they are not both at ground potential. Connecting them together will damage the amplifier and void the warranty!

As the currents involved are very high, and to ensure best performance, the speaker cables should be kept as short as possible and conform to the following minimum requirements:

E100, 20A into 4 Ohm speaker loads

When operating the amplifier into loads of less than 4 Ohms, be aware that the current capacity of the speaker cables will need to be increased above the values quoted here.

Do not connect the inputs/outputs to any other voltage source such as a battery, mains source or power supply, regardless of whether the amplifier is turned on or off.

Do not run the output of any amplifier channel back into another channel's input and do not parallel or series-connect an amplifier output with any other amplifier output.

Connecting To Your Amplifier: Bridged (Mono) Operation

Pairs of channels may be independently bridged – channel pair A&B, and/or channel pair C&D.

The method is the same for both channel pairs:

Supply signal to Channel A or C input only and push in the appropriate rear panel switch marked “BRG A&B” or “BRG C&D”.

Use Channel A or C’s Output Speakon connector and connect as follows:

Pin 2+: Hot
Pin 1-: Cold

When operating in bridged mode, the minimum impedances are doubled.

The minimum load in bridged mode is 4 ohms.

Operating Your Amplifier: Front Panel Controls and Indicators

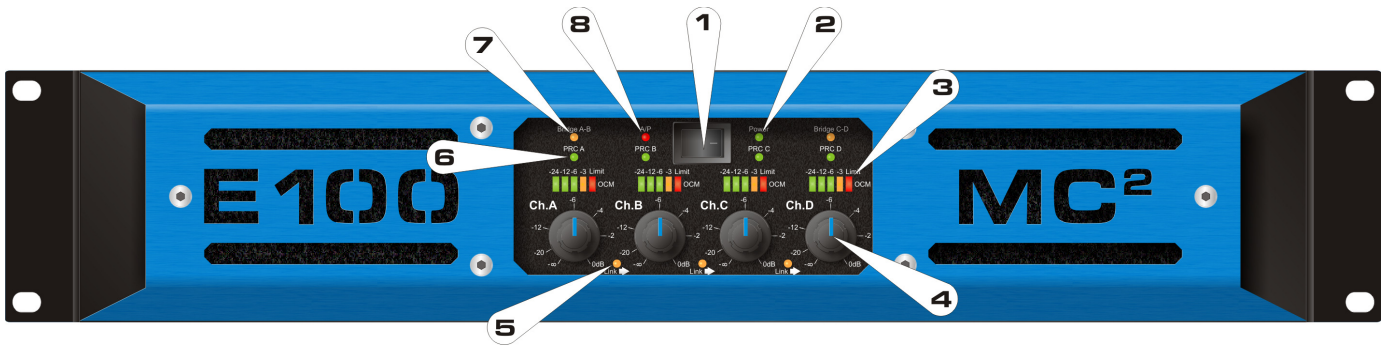

1: Power Switch: This single pole switch turns the amplifier fully off (but does NOT isolate it from the mains supply).

2: Power LED: This indicates when the amplifier is active. This does NOT indicate the presence of a mains supply when the power switch is OFF.

3: Signal Meter and OCM indicators: These LED bar graphs show instantaneous level on each channel to indicate proximity to the limiter threshold. Note that if the PRC system is in operation on any channel, this will affect the readout shown on the respective meter.

The red LED in the meter will illuminate when the limiter threshold has been reached and limiting is occurring. The output current monitor (OCM) may activate to limit the output current of the amplifier channel - this can occur even if the amplifier has not reached clipping point.

The OCM indicator can operate independently of the bar graph meter. Typical conditions that may trigger the OCM circuitry would be very low load impedance, or high subsonic or VHF levels.

4: Attenuation Controls: These are analogue controls allowing precise level settings. Note that in bridged (mono) mode some controls may be inactive.

5: Link LED: This indicates if the channel is linked to its immediate neighbour. If this is illuminated, the attenuation control of the channel to the immediate right will not function as both channels are being fed from the left hand channel. The link switches are on the rear panel – see page 16 for details.

6: PRC LED: This illuminates if the Power Reduction Control has been enabled on the respective channel. PRC switches are on the rear panel – see page 16 for details.

7: Bridge LED: This illuminates when a channel pair have been switched into bridged (mono) mode (channel A+B or C+D). Note that the partner channel's LEDs and controls are disabled when a pair of channels are bridged. Bridge switches are on the rear panel – see page 16 for details of how to connect your speaker to a bridged channel pair.

8: A/P (Auto Protect) LED: If a condition exists, either internally or externally, that could cause damage to either the amplifier or the speakers, the protection circuit will disengage the outputs and the A/P LED will illuminate. The amplifier will continue to be monitored and depending on the type of fault, will either reset after the fault has cleared or require manual resetting by switching off at the mains switch and then on again after a few seconds.

Typical conditions that could cause the protection to be triggered include very high frequency or subsonic input signals, DC in the inputs, short-circuited outputs, or internal high temperatures.

The protection circuit can affect all channels or a 'channel pair' depending on the type of fault. This is indicated by the combination of A/P LED and OCM LED illuminating. In this way it is possible for two channels (a channel pair) to remain functioning even though a fault has caused the other channel pair to mute. A channel pair would be A+B or C+D.

Temperature related faults will reset if the unit has cooled sufficiently.

Output short circuits will require manual reset after clearing the fault. Short circuits on either channel of a channel pair will only affect that channel pair. A/P will illuminate together with the OCM LED on the shorted channel and the partner channel of the channel pair (so A+B or C+D).

Operating Your Amplifier: Notes and Switching On

Read all documentation before operating your equipment and retain all documentation for future reference.

Do not spill water or other liquids into or on the unit and do not operate the unit while standing in liquid.

Do not block fan intake or rear ventilation outlets or operate the unit in an environment that could impede the free flow of air around the unit.

If the unit is used in an extremely dusty or smoky environment, it should be cleaned of any collected debris at regular intervals. Please also see the notes regarding maintenance on page 17.

It is important that the power output of your amplifier is matched to the power handling capacity of your loudspeaker. If not, damage to the loudspeaker could occur.

Switching On...

At 'switch-on' the protection circuit will initially activate whilst the circuits stabilise, indicated by the red A/P LED illuminating, in addition to various other LEDs. After a few seconds the red A/P LED will extinguish indicating a satisfactory working condition.

Other LEDs may remain illuminated depending upon rear panel switch settings and input connections. If the A/P LED does not extinguish after 5 seconds the unit may be faulty or some external connections may be incorrect or inappropriate. If this occurs you should power down the unit and remove all external connections (except for the mains power supply) and repeat the power up sequence. If the problem persists please contact us – details on page 17.

Operating Your Amplifier: Rear Panel Sockets and Switches

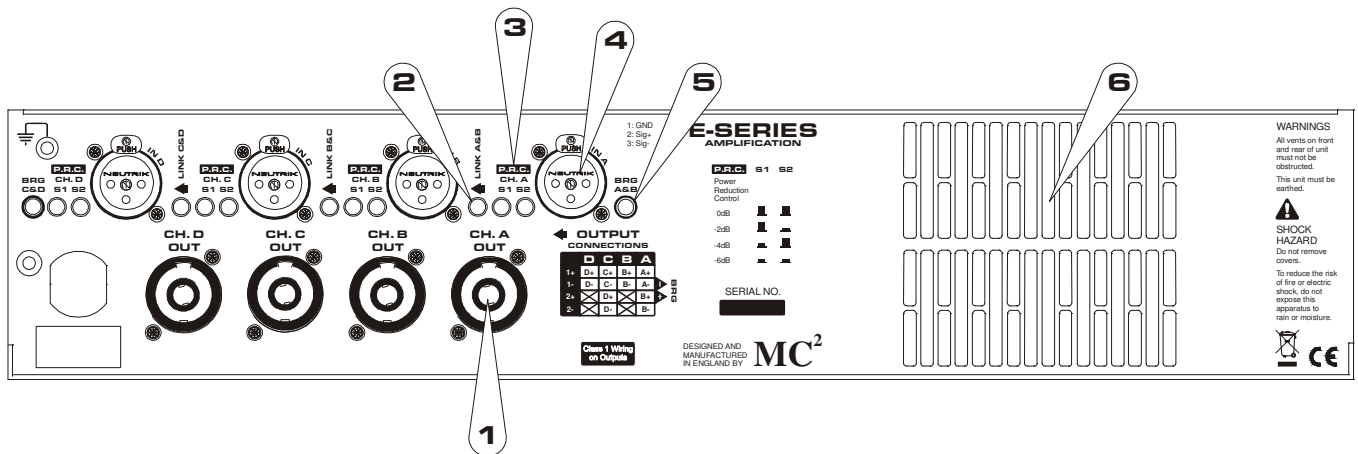

1: Channel A output Speakon socket: Normal output is on pins 1+ hot, 1- cold. Channel B's output is also wired to this socket to enable a single NL4 to provide both channels and to facilitate easier wiring in bridged mode. Channel B is wired pins 2+ hot, 2- cold.

Similarly channel C's output Speakon socket carries Channel D's output. Check the table on the rear panel for details.

2: Link switch: Press this switch to link the input of the channel to its immediate left. Multiple channels may be linked using these switches so, for example, to link all outputs to input A, press all three switches IN and use input A only. The front panel attenuators will still operate independently when channels are linked.

3: PRC switches: Each channel of the amplifier may be power limited independently using these pairs of switches in three stages, offering 2, 4 and 6dB of Power Reduction Control.

P.R.C.	S1	S2
Power Reduction Control		
0dB	■	■
-2dB	■	■
-4dB	■	■
-6dB	■	■

The settings for these switches are on the rear panel for quick reference.

4: Input XLR sockets: Connect signal inputs to these sockets, wired pin 2 hot, 3 cold, 1 ground. For sensitivity and impedance of these inputs, please see the specifications on page 18.

5: Bridged (mono) switch (A+B): Press this switch to run this pair of amplifier channels in bridged mode. To run C+D bridged, press the switch on the far left of the panel, beside channel D's input XLR.

6: Fan outlet: The variable speed fans suck air in through the front vents and out through the back of the amplifier. Please see maintenance on page 17 for recommendations on how to clean this and the front foam sections.

Looking After Your Amplifier: Maintenance

These maintenance instructions are for use by qualified personnel only. Before any routine maintenance, please ensure that your amplifier is disconnected from the mains supply!

The filter behind the air intake apertures on the front of your amplifier should be cleaned or replaced periodically, e.g. 12-24 months. (Filters in amplifiers located in more 'dirty' atmospheres may require more frequent maintenance).

The filter should be 'dry' cleaned, using a vacuum cleaner preferably. Running the unit without a filter is not recommended unless it is within a 'clean room'. Replacement filter material is available.

If the fan vents on the rear of the amplifier develop a build-up of dust/debris on the finger guards, they can be cleaned with a dry paintbrush and a vacuum cleaner.

The casework of the amplifier may be cleaned with a lightly dampened cloth – do not use any solvents as they will damage the paint finish and could remove printing.

If you have any doubts about carrying out maintenance, please refer to a service engineer or contact your local dealer.

Looking After Your Amplifier: Warranty

Your amplifier is guaranteed for a period of five (5) years from the date of purchase. We hope that it gives you many more years of reliable service than this, but should anything go wrong, please contact us to advise you about repairs or any spares you might require.

Please do not attempt to repair the amplifier yourself as doing so will invalidate the warranty.

Our contact details are:

MC² Audio,
Units 6-8 Kingsgate
Heathpark Industrial Estate
Honiton, Devon
England
EX14 1YG

Tel: +44(0)1404 44633

Fax: +44(0)1404 4466

email: sales@mc2-audio.co.uk for general enquiries

Our website is a great place to get started if you have any questions regarding the general use of your amplifier or need copies of this manual in digital form, or datasheets and photographs. The datasheets also contain architect's and engineer's specifications.

www.mc2-audio.co.uk

Changing the Gain of Your Amplifier: Internal Adjustments!

These instructions are for use by qualified personnel only. Before any routine maintenance, please ensure that your amplifier is disconnected from the mains supply!

Gain/Sensitivity Settings

Adjustment is by moving a link on the input PCB (PCB741) – one link for each channel. Channel A's link is number 1, channel B's is number 2 and so on. The gain may be set to 26, 32 (factory default setting) or 36dB.

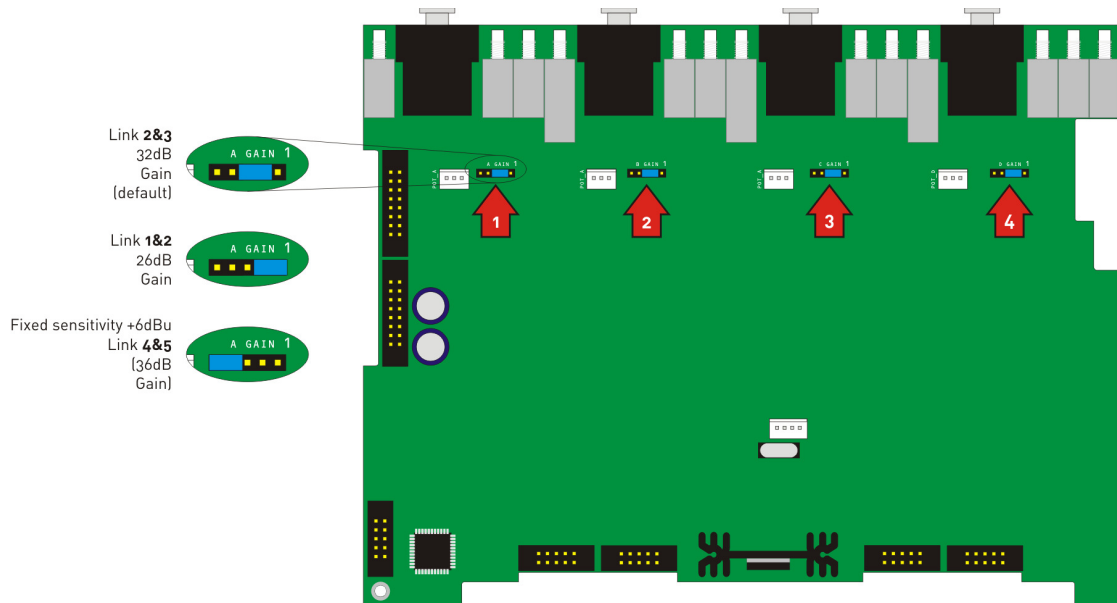

Remember, setting higher gain does not change the maximum available power but changes the level of signal input to achieve maximum power. In any case, provided that the input signal is less than 20dBu/7.7V, the built in limiter circuit will prevent distortion within the amplifier.

The gain should be set to match the signal level from the source – mixer, equaliser etc.

Performance Of Your Amplifier: Specifications

Main Specifications

Parameter (Units)	E100
Output Power per channel [Crest Factor = 4.8] (Watts)	
8 Ohms	1400
4 Ohms	2800
2 Ohms	3700
Output Power per channel bridged [Crest Factor = 4.8] (Watts)	
8 Ohms	5300
4 Ohms	7400
THD+N, 4 Ohms (%)	
@1kHz, 1dB below max output power <	0.08
@20Hz - 20kHz, 1dB below max output power <	0.15
Gain Options (dB)	26 / 32 / 36
Sensitivity Options for max power (dBu)	16.0 / 10.0 / 6.0
Sensitivity Options for max power (Volts)	4.9 / 2.5 / 1.5
Frequency Response, +0/0.5dB (Hz)	20 – 20000
Power Consumption, Nominal @ 240V, 4 Ohms (A)	7.0
Power Consumption, Nominal @ 120V, 4 Ohms (A)	14.0
Dimensions H x W x D (mm)	
Amplifier	88 x 482 x 428
Boxed	230 x 580 x 560
Boxed Shipping – all except UK	250 x 610 x 600
Weight (kgs)	
Amplifier	12.0
Boxed – shipping	14.0

Additional Specifications

Parameter (Units)	E100
Input Impedance – Active Balanced (Ohms)	20k
Input CMRR (dB)	> 60
SNR (dB)	105
Damping Factor, 1kHz, 8 ohms	> 400
Signal Limiters Present	Yes
Protection Present – Short Circuit / DC Output / Temperature	Yes
Mains In-rush Control Present	Yes
Output Power per channel, 8 Ohms (Watts)	
Sine Wave @ 1kHz	1150
Continuous music [Crest Factor of 2.8 or 9dB]	1300
Continuous music [Crest Factor of 4.8 or 14dB]	1400
Continuous music [Crest Factor of 7.8 or 18dB]	1480
Output Power per channel, 4 Ohms (Watts)	
Sine Wave @ 1kHz	2250
Continuous music [Crest Factor of 2.8 or 9dB]	2600
Continuous music [Crest Factor of 4.8 or 14dB]	2800
Continuous music [Crest Factor of 7.8 or 18dB]	2900
Output Power per channel, 2 Ohms (Watts)	
Sine Wave @ 1kHz	3200
Continuous music with Crest Factor of 2.8 [9dB]	3600
Continuous music with Crest Factor of 4.8 [14dB]	3700
Continuous music with Crest Factor of 7.8 [18dB]	3700

Due to continuing product improvement the above specifications are subject to change.

Performance Of Your Amplifier: Specifications

Power Consumption and Thermal Emissions – E100

Mains (V)	Load (R)	Current Draw (A)				Thermal Emissions (W)			
		No Sig'l	Light	Average	Heavy	No Sig'l	Light	Average	Heavy
240	8	2.1	3.0	4.5	8.3	504	528	566	660
240	4	2.1	3.9	7.0	14.4	504	551	628	816
240	2	2.1	4.5	8.6	19.1	504	564	668	936
120	8	4.2	6.0	9.0	16.6	504	528	566	660
120	4	4.2	7.8	14.0	28.8	504	551	628	816
120	2	4.2	9.0	17.2	38.2	504	564	668	936

No Sig'l = Quiescent, Light = Crest Factor of 7.8(18dB),

Average = Crest Factor of 4.8(14dB), Heavy = Crest Factor of 2.8(9dB)

For details of measurement methods please refer to the Technical Support area of our website.

PRC Settings and Maximum Output

Power Reduction Control Setting	Per Channel	Bridged Pair
Maximum Power into 8 ohms (W)	1400	5300
-2dB PRC	980	3700
-4dB PRC	560	2100
-6dB PRC	310	1175
Maximum Power into 4 ohms (W)	2800	7400
-2dB PRC	1950	5160
-4dB PRC	1110	2940
-6dB PRC	620	1640
Maximum Power into 2 ohms (W)	3700	N/A
-2dB PRC	2580	N/A
-4dB PRC	1470	N/A
-6dB PRC	820	N/A