

primoSchwank 40 & supraSchwank 40

HIGH EFFICIENCY COMBINED INTENSITY
Gas-Fired Luminous (High Intensity) Infrared Heaters

INSTALLATION / OWNER'S MANUAL



WARNING Improper installation, adjustment, alteration, service or maintenance can cause property damage, injury or death.

Read the installation and operating and maintenance instructions thoroughly before installing or servicing this equipment.

Not approved for use in any residential application.

SAFETY ALERT:



This heater must be installed and serviced only by a trained gas service technician. Failure to comply could result in personal injury, death, fire and/or property damage.

Do not store or use gasoline or other flammable vapours and liquids in the vicinity of this or any other gas fired appliance.



IF YOU SMELL GAS:

- Extinguish any open flame
- Do not attempt to light this or any other appliance
- Don't touch any electrical switch, or telephone
- Immediately leave the area and call your gas supplier from a neighbor's phone
- Follow any and all instruction from your gas supplier
- If your gas supplier is not available, call the fire department



FIELD CONVERTIBILITY:
This appliance is field convertible to LP gas. Use kit available from manufacturer. See Page 14. Follow all local and national codes.

INSTALLER: PRESENT THIS MANUAL TO THE END USER.

Keep this manual in a secure place .

Record for future reference:

Model #: _____

Serial #: _____

(located on heater rating label)



NOTICE:

This manual is current for this product. Occasional revision of the product Certification Standard may require changes to the product and/or this manual.

This publication, or parts thereof, may not be reproduced in any form, without prior written consent from The Manufacturer. Unauthorized use or distribution of this publication is strictly prohibited.

Schwank Group

Schwank and InfraSave brands

5285 Bradco Boulevard

Mississauga, Ontario, L4W 2A6

PO Box 988, 2 Schwank Way

Waynesboro, Georgia 30830

Customer & Technical Services

Phone: 877-446-3727

Fax: 866-361-0523

e-mail: csr@schwankgroup.com

www.schwankgroup.com

www.infrasave.com

supraSchwank – 40
 primoSchwank – 40
**HIGH EFFICIENCY COMBINED INTENSITY
 GAS FIRED INFRA-RED HEATERS**

TABLE OF CONTENTS

TOPIC	PAGE NUMBER	TOPIC	PAGE NUMBER
1. GENERAL	1	8. SPECIFICATIONS AND DIMENSIONS	6
2. INSTALLATION REQUIREMENTS	1	8.1 DIMENSION DIAGRAM	6
2.1 INSTALLATION IN AIRCRAFT HANGARS	1	8.2 MOUNTING HARDWARE	6
2.2 INSTALLATION IN COMMERCIAL GARAGES	2	8.3 HORIZONTAL MOUNTING DIAGRAM	7
2.3 INSTALLATIONS OTHER THAN SPACE HEATING	2	8.4 SUGGESTED MOUNTING DISTANCE FOR COMFORT	7
2.4 MOUNTING CLEARANCES	2	8.5 HORIZONTAL MOUNTING DISTANCE TO COMBUSTIBLES	8
2.5 HEATER MOUNTING	2	8.6 ANGLE MOUNTING DISTANCE TO COMBUSTIBLES	8
2.6 VENTILATION REQUIREMENTS	3	9. HIGH ALTITUDE INSTALLATIONS	10
2.7 GAS PRESSURE	3	10. SEQUENCE OF OPERATION FOR S87C	10
2.8 ELECTRICAL REQUIREMENTS & THERMOSTATION CONTROL	4	10.1 ELECTRICAL WIRING DIAGRAM	11
3. INSTALLATION PROCEDURES	4	10.2 ELECTRICAL WIRING DIAGRAM USA	12
4. LIGHTING INSTRUCTIONS	5	10.3 TROUBLESHOOTING GUIDE	13
5. SHUT DOWN INSTRUCTIONS	5	11. SPARK IGNITION CIRCUIT	16
6. AIR BORNE PARTICLES	5	12. START UP SHEET	17
7. SERVICE GUIDE	5	13. OPTIONAL COMPONENTS	19
		14. LIMITED WARRANTY	23



IMPORTANT

Installer: Present this manual to the end user. Acquaint the end user with Important Information: Cover & pages 4 to 8.



END USER: In particular you must be aware of 'Clearances to Combustible' requirements and the limitations of stacking or placing material near the heaters.

Make your safety personnel and staff aware of this information.



WARNING



Improper installation, adjustment, alteration, service or maintenance can cause property damage, injury or death. Read and understand this installation and operation manual thoroughly prior to assembly, installation, operation or service to this appliance.



This heater must be installed and serviced only by a trained gas service technician.

Do not store or use gasoline or other flammable vapours and liquids in the vicinity of this or any other gas fired appliance.



Failure to comply could result in personal injury, death, fire and/or property damage.

Do not store or use gasoline or other flammable vapours and liquids in the vicinity of this or any other gas fired appliance.

This appliance may have sharp edges and corners. Wear protective clothing such as gloves and protective eye wear when servicing this or any other appliance.

APPLICATION

A gas-fired luminous (high intensity) radiant heater may be installed for heating of commercial / industrial non-residential spaces. It is beyond the scope of these instructions to consider all conditions that may be encountered. Installation must conform with all local building codes or, in the absence of local codes, with the National Fuel Gas Code, ANSI Z223.1/NFPA 54 in the U.S.A. or the Natural Gas and Propane Installation Code, CSA B149.1 in Canada. The latest edition Electrical Code ANSI/NFPA N0 70 in the U.S.A. and PART 1 CSA C22.1 in Canada must also be observed.

Installation of a gas-fired radiant heater must conform to all heating installation design procedures including clearance to combustibles, connection to the gas and electrical supplies, and ventilation.



WARNING

This heater is not for installation in a Class 1 or Class 2 explosive environment, nor for any residential application. If installation of this equipment is in question, consult with local authorities having jurisdiction (Fire Marshall, labor department, insurance underwriter, or others).

Revisions to codes and/or standards, may require revision to equipment and installation procedures. In case of discrepancy, the latest codes, standards, and installation manual will take priority over prior releases.

IMPORTANT: DO NOT INSTALL THIS HEATER IN A STRUCTURE WITH NO INSULATION IN THE ROOF—CONDENSATION WILL OCCUR.



WARNING

Heater Expansion



It is a normal condition that during heat-up and cool-down a radiant heater will expand and contract. Allowances for heater expansion must be made in the gas connection and heater suspension. Improper installation, alteration, or adjustment can result in property damage, injury or death.



WARNING

Gas Connection



Improper installation, connection, or adjustment can result in property damage, toxic gases, asphyxiation, injury or death. Use an approved stainless steel flexible gas connector (field supplied) to connect to the gas supply to the heater in accordance with all local, state, provincial, and national codes (ANSI Z223.1/NFPA 54 in USA; B149.1 in Canada) and as indicated in this manual.



WARNING

Venting



Inadequate venting of a heater may result in asphyxiation, carbon monoxide poisoning, injury or death. This heater is indirectly vented from the space. Venting must be in accordance with all local, state, provincial, and national codes (ANSI Z223.1/NFPA 54 in USA; B149.1 in Canada) and as indicated in this manual.

Refer to Sections 11 & 12



WARNING

'Smoke' & Discoloration Condition

During start-up, the heating of material coatings used in the production process of the heater may create a small amount of smoke during the initial period of operation. This condition is normal and temporary .

Ensure that there is sufficient ventilation to adequately clear any 'smoke' from the space.

Notify site management and safety personnel to ensure that alarm systems are not unduly activated.

Under certain conditions in some locations/environments, surface discoloration may occur on the heater body where the products of combustion discharge from the heater. **This discoloration is due the deposit of ambient air borne particulate or gases that have passed through combustion. The combustion of fuel gas in a clean environment will not cause any discoloration. The discoloration does not affect the operation of the heater nor the manufacturer's warranties.**



WARNING

Clearance to Combustibles

Location of flammable or explosive objects, liquids or vapors close to the heater may cause fire or explosion and result in property damage, injury or death. Do not use, store or locate flammable or explosive objects, liquids or vapors in proximity of the heater.



The clearance to combustible material represents the minimum distance that must be maintained between the outer heater surface and a nearby surface. The stated clearance to combustibles represents a surface temperature of 90F° (50C°) above room temperature.



It is the installer's responsibility to ensure that building materials with a low heat tolerance which may degrade at lower temperatures are protected to prevent degradation. Examples of low heat tolerance materials include vinyl siding, fabrics, some plastics, filmy materials, etc.

In locations used for the storage of combustible materials, signs must be posted to specify the maximum permissible stacking height to maintain the required clearances from the heater to the combustibles. For your convenience, a sign is supplied with this heater - see page 8 for details. Such signs must either be posted adjacent to the heater thermostats or in the absence of such thermostats in a conspicuous location.

In addition to stored or stationary material, consideration must also be given to moveable objects such as cranes, vehicles, and overhead doors, and structural objects such as electrical and gas lines, electrical fixtures, and sprinkler heads.

Heaters must be located an appropriate distance from sprinkler heads. This distance may be greater than the certified clearance to combustibles. Check the temperature rating of the sprinkler heads and locate heaters at a safe distance - in some instances the sprinkler heads may need to be replaced by higher temperature heads.

It is beyond the scope of these instructions to consider all conditions that may be encountered. Consult local authorities such as the Fire Marshall, insurance carrier, or safety authorities if you are uncertain as to the safety or applicability of the proposed installation.

Refer to Figure 1 and Table 1 NEXT PAGE for the certified clearances to combustibles for the appropriate model input/size.

MOUNTING CLEARANCE TO COMBUSTIBLES



NOTE: A 'PEEL & STICK' SIGN IS SUPPLIED: USE AN INDELIBLE MARKER TO ENTER VALUES 'H', 'S', 'F', & 'B' ON .
POST THE SIGN ADJACENT TO THE HEATER THERMOSTAT OR IN A PROMINENT LOCATION. See next page for details.

FIGURE 1: MINIMUM DISTANCES TO COMBUSTIBLES - refer to Table 1 for values

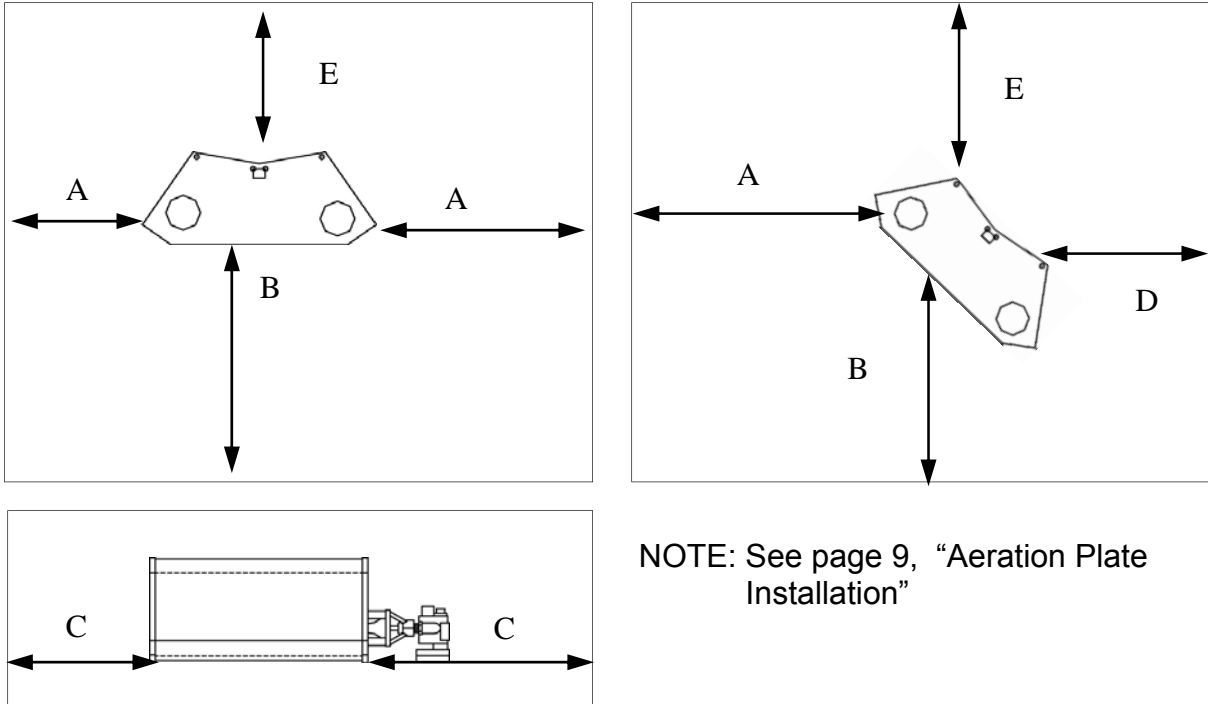

TABLE 1: CERTIFIED MINIMUM CLEARANCE TO COMBUSTIBLES, MEASURED FROM EDGE OF BURNER

HORIZONTAL MOUNT	FRONT OF HEATER < A >	BOTTOM OF HEATER < B >	ENDS OF HEATER < C >	REAR OF HEATER < D >	TOP OF HEATER < E >
primoSchwank -40	45"	110"	48"	45"	26"
supraSchwank- 40	40"	110"	48"	40"	20"

ANGLE MOUNT UP TO 30°	FRONT OF HEATER < A >	BOTTOM OF HEATER < B >	ENDS OF HEATER < C >	REAR OF HEATER < D >	TOP OF HEATER < E >
primoSchwank -40	78"	36"	48"	8"	48"
supraSchwank- 40	78"	36"	48"	8"	48"

2.2 INSTALLATION IN COMMERCIAL GARAGES

The **Schwank** Combined Intensity Heaters are suitable for use in commercial garages when installed in accordance with ANSI/NFPA No. 88B 1985 (latest edition), which states clearances to combustible construction or material in storage, from heater and vent, must conform to standard NFPA No. 54 (ANSI Z223.1 latest edition), in

the U.S.A. and the CSA B149, and CAN1.2.16-M81 in Canada. "Overhead heaters shall be installed at least (8) feet above the floor". In addition, they shall be located high enough to maintain the minimum distance to combustibles, as shown on the heater rating plate, between the heater and any vehicles parked below the heater

2.3 INSTALLATIONS OTHER THAN SPACE HEATING

Use for process applications will void the C.S.A. certification and require governing authority field certification at the installer's / owner's responsibility and expense.

2.4 MOUNTING CLEARANCES

The primoSchwank / supraSchwank Combined Intensity Heater must be mounted with minimum clearances as shown in sections 8.3 and 8.5. It should also be located with

respect to building construction and equipment so as to provide sufficient clearance and accessibility for servicing and cleaning of burners and ignition control.

WARNING: **The Schwank Combined Intensity Heaters cannot be installed inside degreasing plants, nor can they be in an area where chlorine, fluorine or bromine are present.**

2.5 HEATER MOUNTING

The **Schwank** Combined Intensity Heaters are approved for both horizontal and angle mounting. When angle mounting, the short axis may be rotated to a maximum of 30 degrees. The Venturi alignment varies with NG and LPG applications. Therefore it is very im-

important, and critical to install the heaters with the venturi positioned as per the manufacturer's instructions. Improper angle mounting can result in damage to the heater or unsafe operation.

IMPORTANT:

For either horizontal or angle mounting, the long axis of the heater body must be level. Use only non-combustible mounting hardware. Diagrams 2 on page 6 illustrate typical suspension hardware that is approved.

2.6 VENTILATION REQUIREMENTS

In Canada it is required by law that an unvented heater be electrically interlocked to an independent exhaust fan by means of an Air Proving Switch. The exhaust fan must be sized to create 3 Cfm for every 1000 Btu/hr or fraction thereof, of total input of installed equipment. Consult CSA.B149.1-00 latest edition for requirements. In the USA when a heater is installed unvented the system re

quires the exhausting of at least 4 Cfm per 1000 Btu/hr on NG, and 4.5 Cfm per 1000 Btu/hr for LP. By natural or mechanical means, or electrically interlocked to an independent exhaust fan, for the total input of all heaters installed. Exhaust openings for removing flue products shall be above the level of the heaters.. Consult your local codes and ANSI Z223.1 latest edition.

- A. All piping must be installed according to local codes.
- B. It is recommended to install an approved flexible connector between the heater and gas piping available as option from Schwank.
- C. A drip-pocket at the inlet connection must
- D. On propane-fired units, a main line filter is recommended.
- E. Piping joint compounds must be resistant to the action of liquefied petroleum gases.
- F. All piping joints should be tested for leaks with a soap and water solution.

CAUTION: Do not install any gas piping in heat zones. Do not subject heater controls to leak test pressures when checking the main supply piping.

2.7 GAS PRESSURE

The maximum supply pressure must be limited to 14" W.C. (0.5 psi). If the line pressure is above 14" W.C., then a separate pressure reducing regulator must be used. The minimum pressure at the inlet to the heater regulator must be equal to or greater than 6.0" w.c.

for NG and 11.0" w.c. for LPG. A sealed regulator is supplied with the heater which maintains the proper manifold pressure when the main burner is operating under the following pressure:

	<u>LINE PRESSURE (inches w.c.)</u>		<u>MANIFOLD PRESSURE (inches w.c.) AT TAP IN GAS VALVE</u>
	<u>MINIMUM</u>	<u>MAXIMUM</u>	
NATURAL GAS	6.0	14.0	5.0
PROPANE GAS	11.0	14.0	10.0

Natural gas models are orificed for 1000 BTU/CU FT., and propane gas models are orificed for 2500 BTU/CU FT.

2.8 ELECTRICAL REQUIREMENTS AND THERMOSTAT CONTROL

All electrical installations must meet local and Canadian Electrical Code Part CSA C22.1. Single heater requires 24 Volt, 60 Hz electrical transformer sized at 40 VA. If multiple heaters are connected to a single transformer, the proper transformer is 24 Volt, 60 Hz, sized at 20 VA per heater. For example, five heaters wired together (parallel), require a transformer of 100 VA.

It is not recommended to install more than 12 heaters per zone. PROPER WIRING POLARITY MUST BE MAINTAINED, particularly when grouping the heaters in a zone.

Total wiring distances of up to 200' must use minimum 16 gauge electrical wire, and wiring distances of over 200' must use minimum 14 gauge electrical wire. The heater must be electrically grounded in accordance with the electrical code.

The heater can be controlled by a line voltage thermostat, a black bulb sensor with control or "off-on" switch. Total load of all heaters must be considered in determining the required contact rating of the controlling thermostat or switch.

3. INSTALLATION PROCEDURES

- A. Properly install gas line as outlined in section 2.7, on page 3.
- B. Properly connect the ignition control assemblies to the heater.
- C. Mount heaters by using non-combustible mounting hardware as illustrated in Diagrams 2 & 3 on page 7. Observe the minimum clearances as outlined in sections 8.3 and 8.7.
- D. Connect heater to the main gas line. It is recommended to use a 1/2" flexible connector to absorb gas line expansion and any building vibration (available as option from Schwank Inc.)
- E. Mount thermostat at desired location, away from direct infra-red rays of heater and not on cold wall without sufficient insulation backing. Install exhaust fan, air switch and transformer, as per section 2.6, page 3 and section 2.9, page 4.
- F. Check gas line for leakage by using soap test or gas meter test. Ensure gas pressure meets the requirements outlined in section 2.8, page 3.

WARNING: When testing the main gas line pressure, ensure the gas shut-off valve supplying the heater is "OFF", otherwise damage to the combination gas valve will result.

- G. Ensure proper electrical rating in the system by checking voltage at ignition module terminals. To avoid system malfunction, the voltage range must be within 21.6 volts to 26.4 volts.
- H. Test fire the heating system by following the lighting instructions as shown on the next page and on heater.

4. LIGHTING INSTRUCTIONS

- A. Open the isolation valve in the main gas line. Turn gas control knob on the combination gas valve, to the “ON” position.
- B. Switch on electrical circuit by turning the thermostat to the highest temperature setting.
- C. The heater should attempt ignition and remain lit within thirty seconds. Note that the corresponding exhaust fan is operating properly.
- D. If ignition does not occur, then cut off electrical power by turning the thermostat to off position.

WARNING: If heater back-fires during operation, then it must be turned off immediately.

Indication of back-firing:

- A. Loud ignition noise, then followed by distinct hissing sound.
- B. Little or no visible burning on the ceramic tile.
- C. Combustion is taking place inside the burner body.

Cause & remedy of back-firing:

- A. Improper gas pressure entering the venturi tube: - check pressure.
- B. Breakage of a ceramic tile and or gasketing: - replace damaged part.
- C. Faulty sealing of the ceramic tile to the burner body, caused by breakdown of gasketing material: - contact your Schwank distributor.

5. SHUT DOWN INSTRUCTIONS

- A. Turn off electrical circuit for temporary shutdown.
- B. Turn off the electrical circuit and turn gas control knob to the “OFF” position

6. AIR BORNE PARTICLES

Under certain conditions, heater may discolour due to ambient air borne particle deposits on the outside surface of the delta chamber. These deposits in no way affect the operation of the heater nor the manufacturer’s warranties.

7. SERVICING GUIDE

Servicing of heater is essential for continued efficient operation, servicing should be carried out annually by qualified service personnel.

- A. Clean the ceramic tile with compressed air, avoid directing air stream at the gasket

material between tile and heater body.

Air pressure must be lower than 20psi.

- B. Clean the venturi tubes with compressed air.
- C. Clean the reflectors.

8.0 SPECIFICATIONS AND DIMENSIONS FOR 40KW COMBINED INTENSITY HEATERS

8.1 DIMENSION DIAGRAM

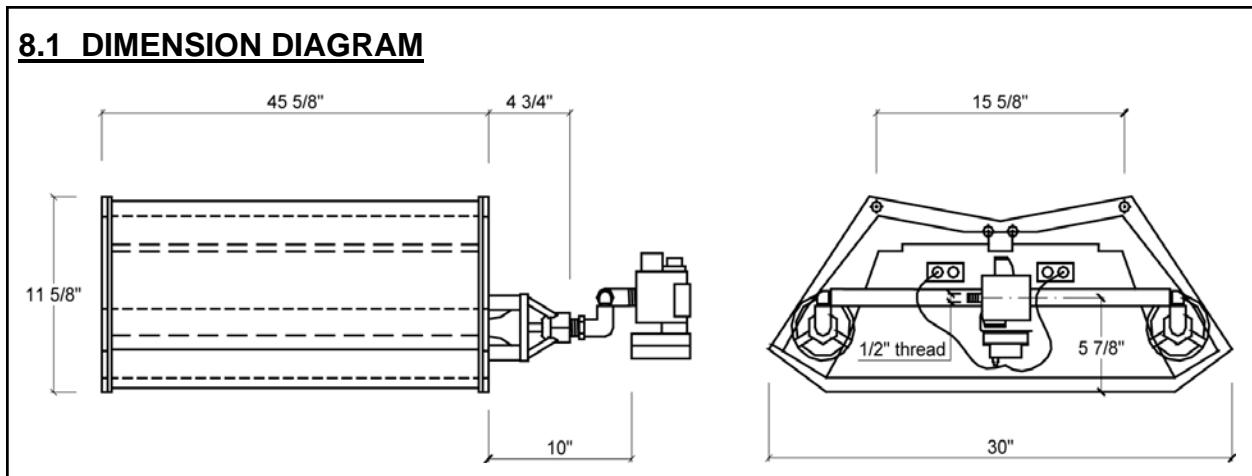
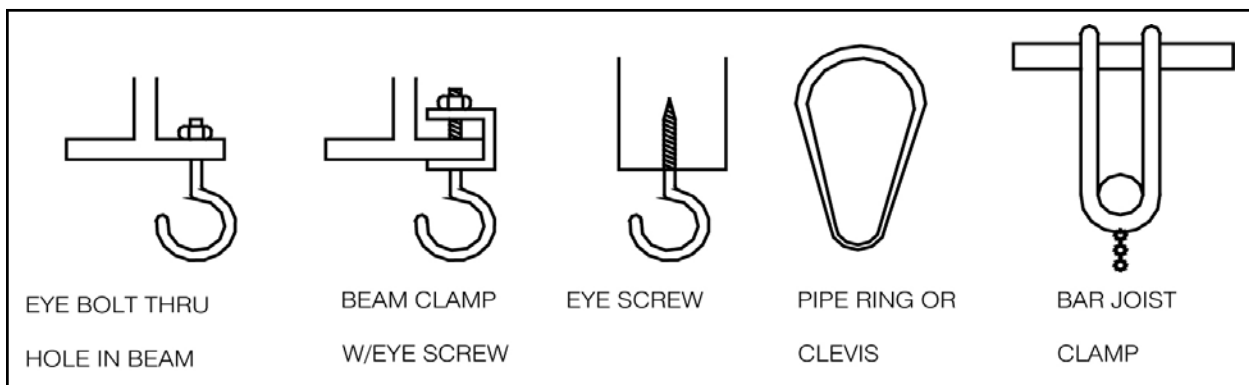

TABLE 1: SPECIFICATIONS

MODEL	VOLTAGE VAC	CURRENT AMPS	CAPACITY (BTU/HOUR)			TOTAL WEIGHT Lbs.
			GAS TYPE	BTUH INPUT	BTUH IR OUTPUT	
supraSchwank 40	24	0.55	NG LPG	118,000 109,000	95,600 88,500	120
primoSchwank 40	24	0.55	NG LPG	150,000 137,000	101,600 89,200	79

8.2 MOUNTING HARDWARE

DIAGRAM 2: SUSPENSION HARDWARE (supplied by others)



8.3 HORIZONTAL MOUNTING DIAGRAM FOR COMBINED INTENSITY HEATERS

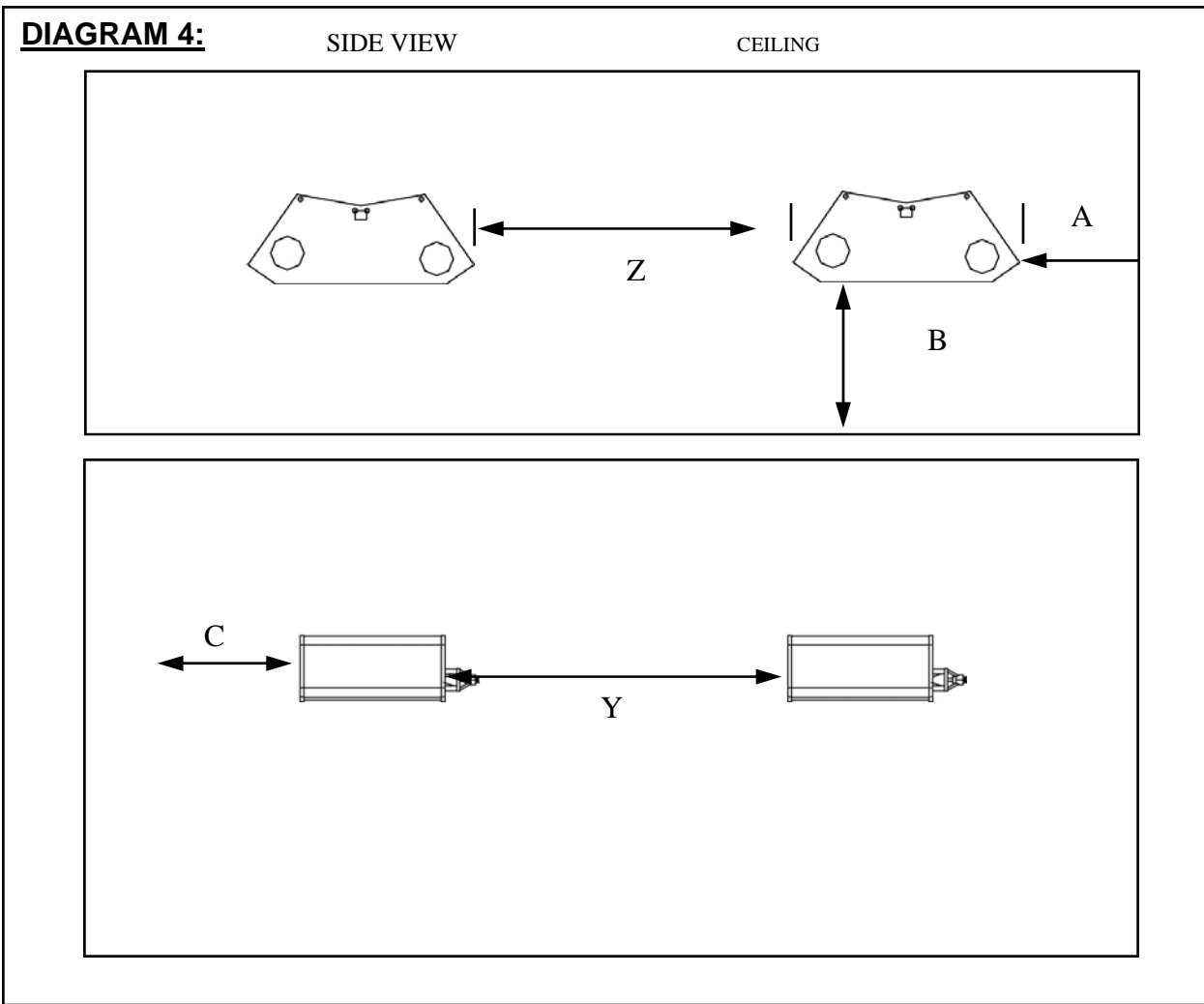

8.4 SUGGESTED MOUNTING DISTANCES FOR COMFORT*

MODEL	BOTTOM 	FRONT <A>	MAXIMUM DISTANCE BETWEEN HEATERS <Y>	MAXIMUM DISTANCE BETWEEN ROWS <Z>
primoSchwank- 40	26'-32'	32"	22-40'	130'
supraSchwank-40	28'-34'	34"	22-40'	130'

** These mounting distances are suggested and are subject to on sight conditions. If in doubt, please contact your Schwank distributor.

SUPRA / PRIMO-40 AERATION RESTRICTOR PLATE

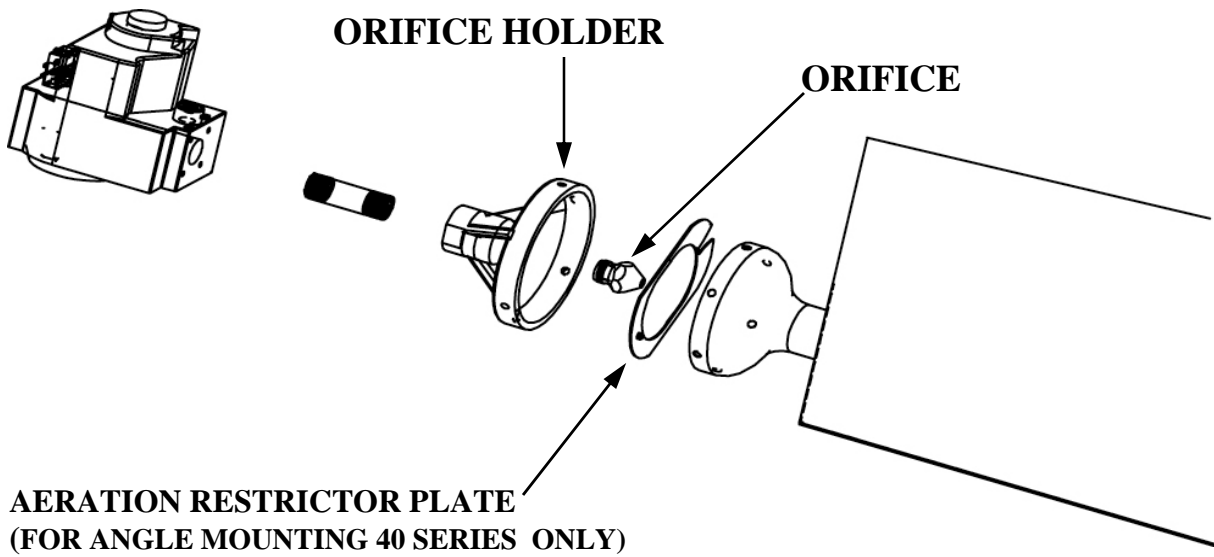

For Angle mounting Only : (Aeration Plate not required for horizontal mounting)
 install the Aeration Restrictor Plate supplied, onto the Lower Orifice Holder. Slide plate inside and down over the orifice and locate the V across the bottom of the spoke. Push the top of the plate in toward the orifice holder locking it in place using the small dimple located at the top of the plate. take care to angle the plate during installation to avoid damaging the orifice face.

ANGLE MOUNTED

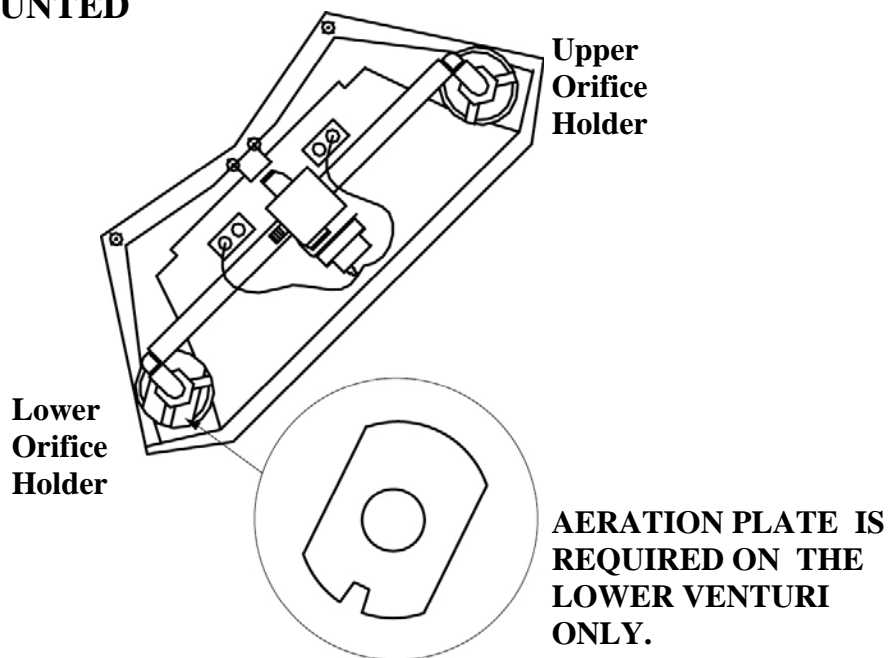

9. HIGH ALTITUDE INSTALLATIONS

In **Canada** all of our Luminous heaters are approved for altitudes zero to 2000 ft above sea level, or 2000 ft to 4500 ft above sea level and must be ordered as such, for either High or Low altitude.

In the **USA** if a heater is to be installed at altitudes above 2000 ft, the input must be reduced by 4% per 1000 ft and the orifice must be changed. (Contact your local distributor or Schwank for further technical information).

10. SEQUENCE OF OPERATION FOR HONEYWELL S87C DSI CONTROL

1. On A call for heat the S87C DSI Control will check for a false flame condition / short to ground. The module will lock out if a false flame condition is present. (Reset is usually done from the Thermostat manually).
2. Spark (30,000 volts) is generated at the Spark Ignition Stud, for direct ignition of the main Burner by the single Spark Igniter.
3. Main Gas Control Valve is powered and OPENS lighting off the Main Burner.
4. Separate Flame Sensor, relays the presence of Main Burner flame back to the DSI Control by a rectified dc voltage signal. (TFI period)
5. If this dc signal is a minimum of 1.5 uA (microamps) the flame remains established and the DSI Control discontinues the ignition spark.
6. This is the 21 second T.F.I (Trial For Ignition) period where flame has to be established first, and confirmed with a minimum signal strength of 1.5 microamps back to the DSI Control. Failing this the DSI will go into the Safety Lockout Mode and shut down the Burner. (Reset is manually done from the Thermostat).
7. On a loss of power the S87 allows the system to shut down safely. Start up is initiated when power is restored
8. On a loss of Main Burner flame, the timed T.F.I. is repeated. Safety Lock-out occurs if the flame is not re-established within the T.F.I period, (Reset is manually done from the Thermostat.)

10.1 WIRING DIAGRAM - LUMINOUS HEATERS - 24V THERMOSTAT CONTROL

DIAGRAM 11:

See 120V Thermostat Control on next page

Note: Power supply: Provide disconnect means and overload protection as required by local and/or national code..

Maintain polarity at control modules.

* Size system transformer: 40VA first heater + 20VA each additional heater

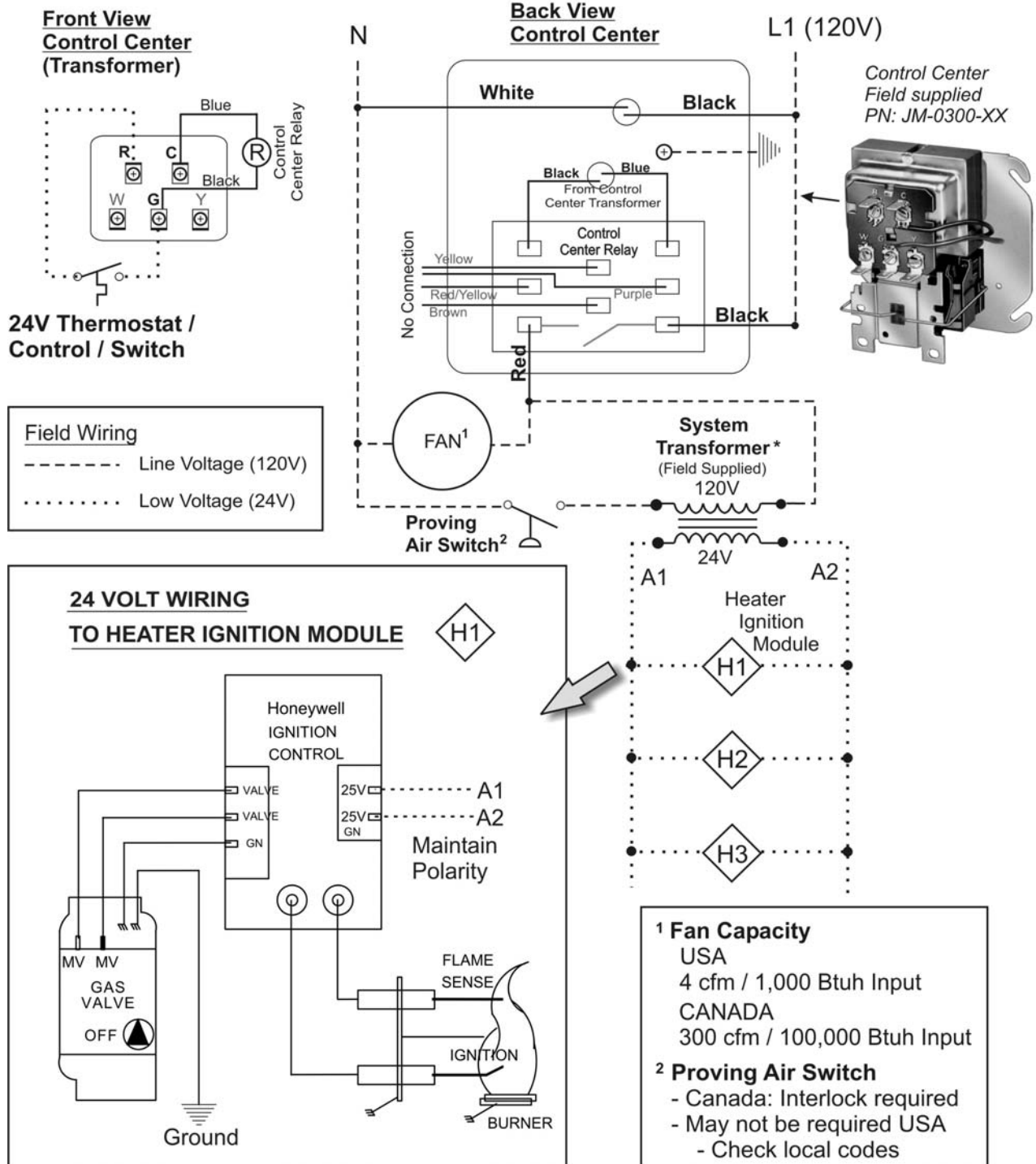

10.2 WIRING DIAGRAM - LUMINOUS HEATERS - 24V THERMOSTAT CONTROL

See 24V Thermostat Control on previous page

DIAGRAM 12:

Note: Power supply: Provide disconnect means and overload protection as required by local and/or national code..

Maintain polarity at control modules.

* Size system transformer: 40VA first heater + 20VA each additional heater

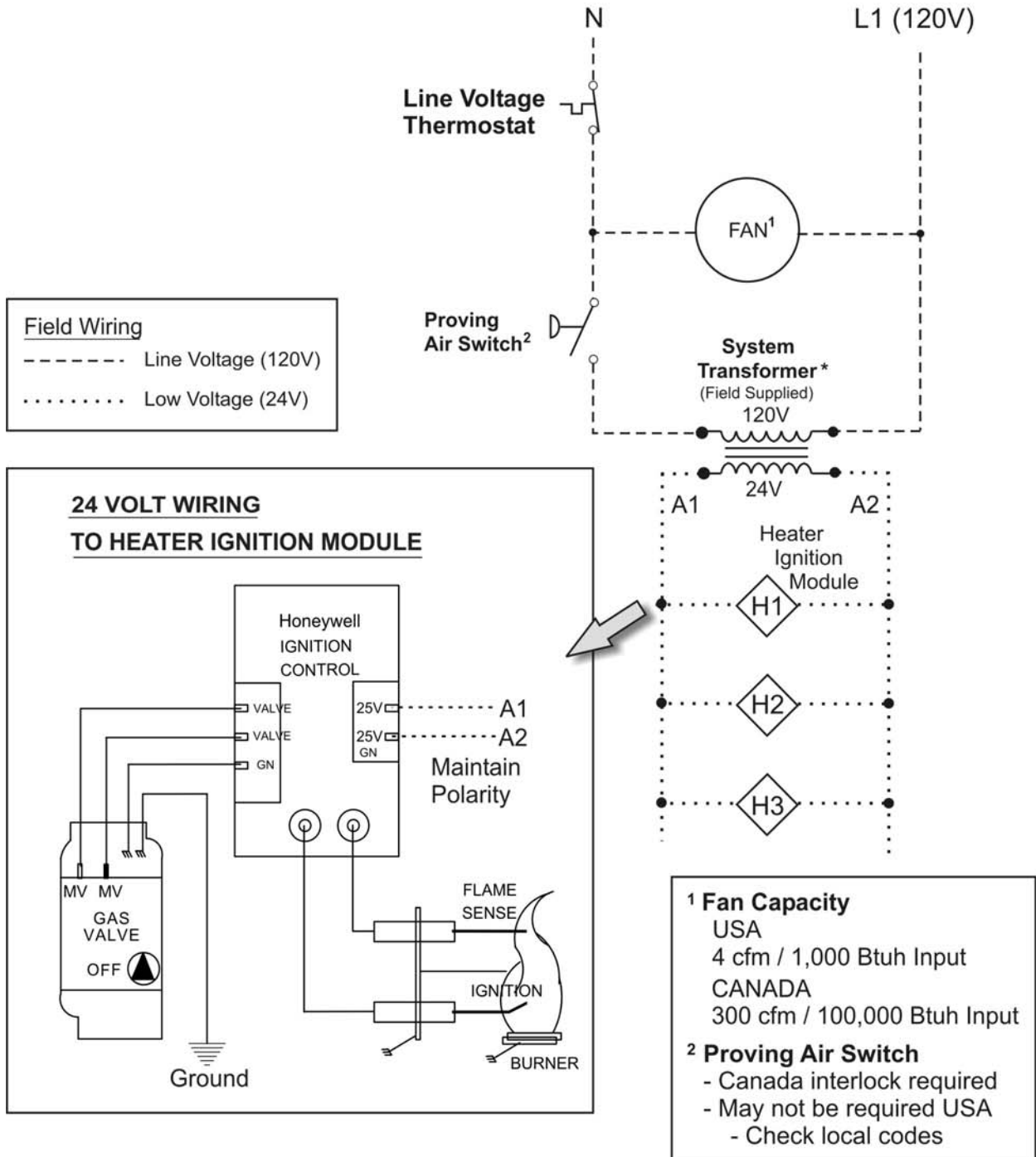

10.3 TROUBLESHOOTING GUIDE

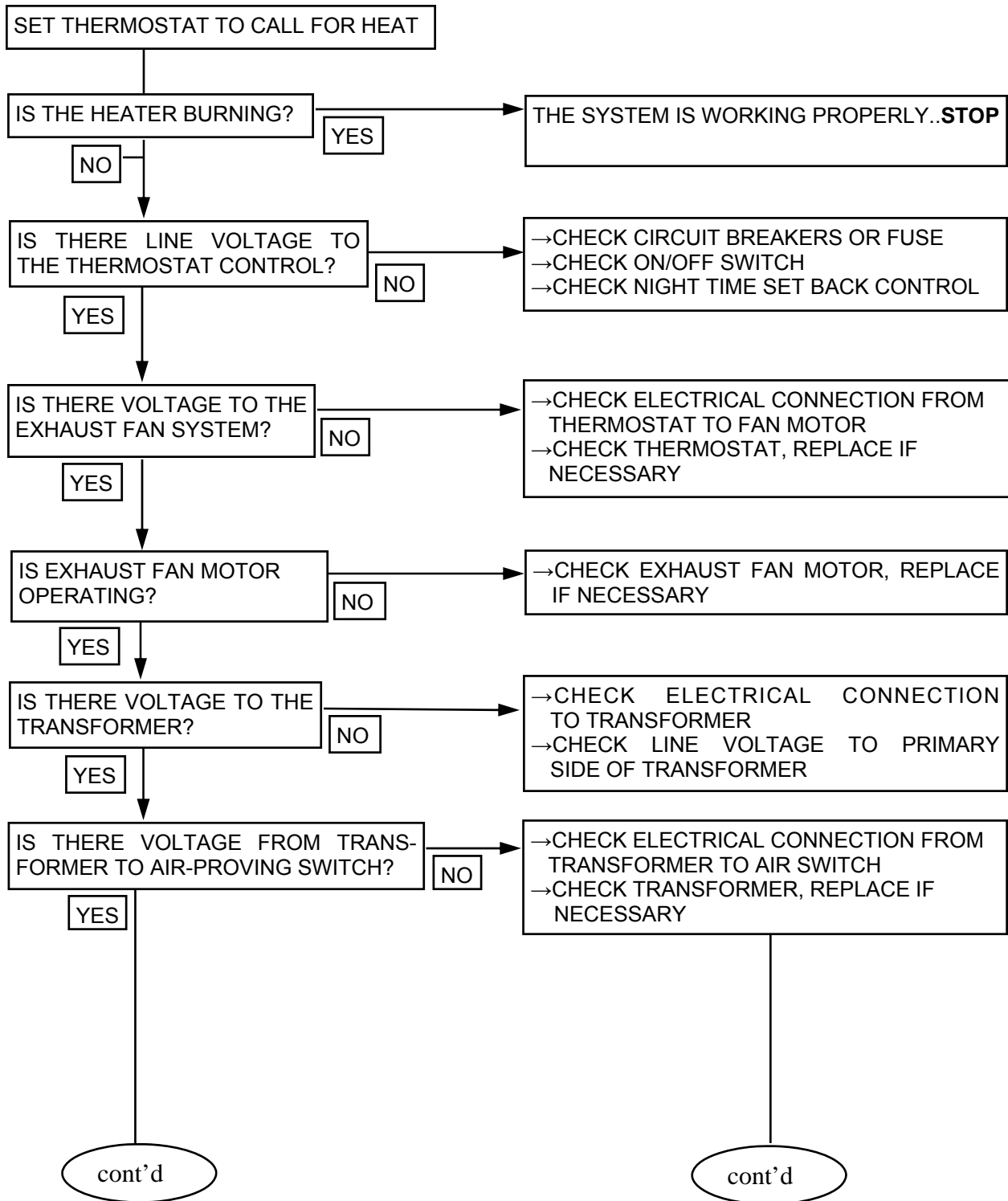

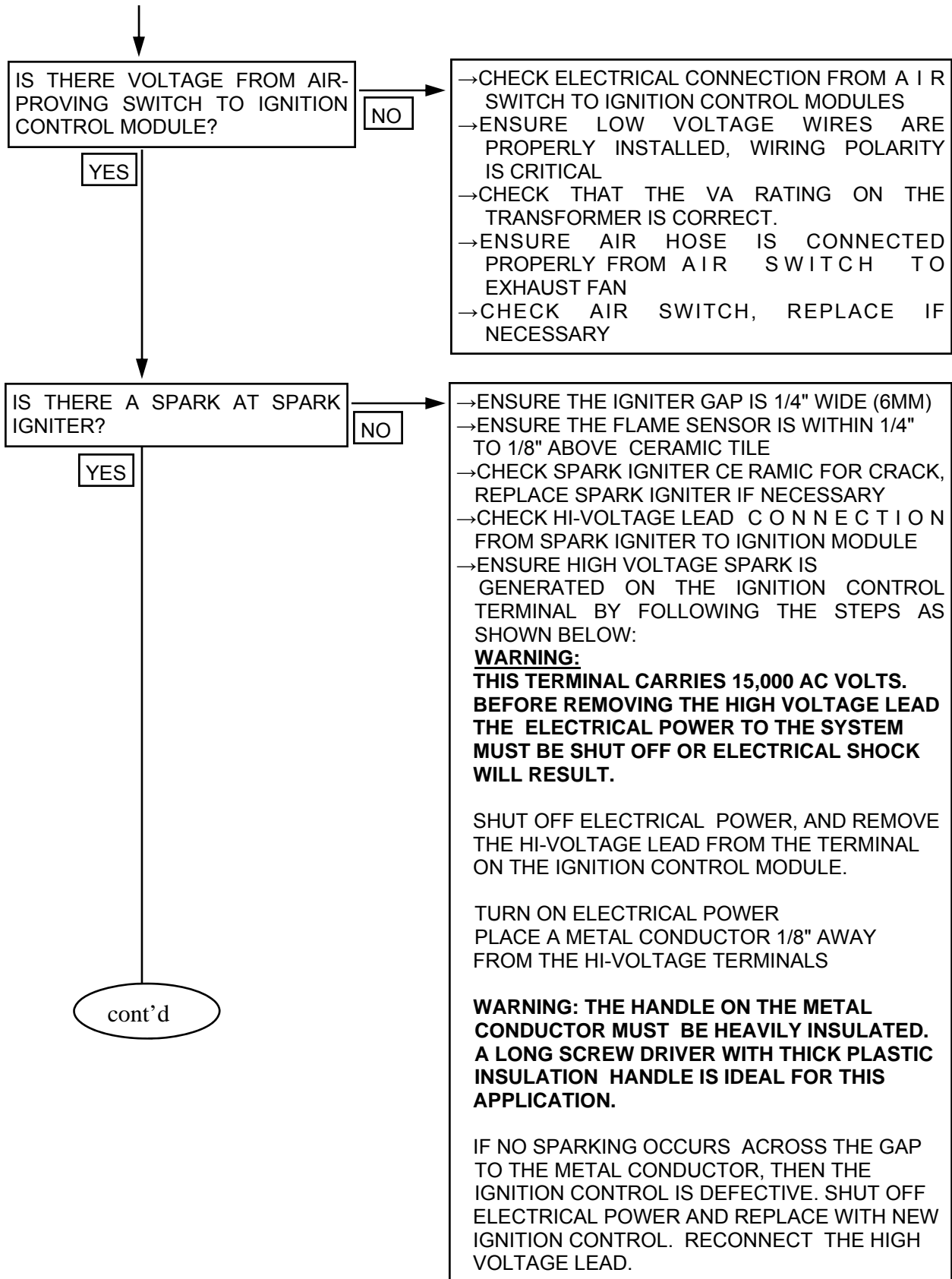

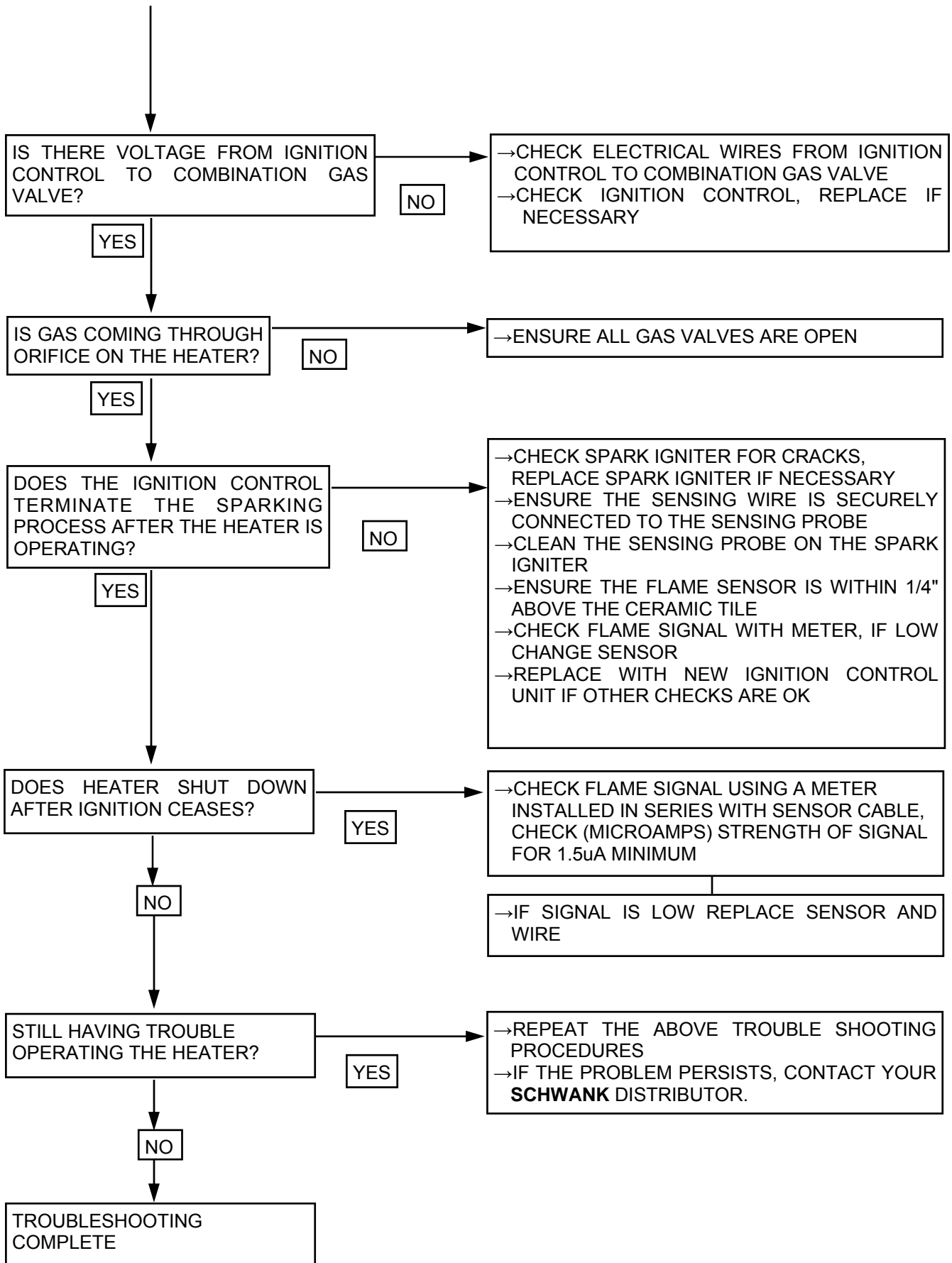

11. SPARK IGNITION CIRCUIT

The step-up transformer in the ignition control provides spark ignition at 30,000 volts (open circuit). To check the spark ignition circuit, proceed as follows.

- 1 Shut off gas supply to the gas control
- 2 Disconnect the ignition cable at the ignition control stud terminal to isolate the circuit from the spark igniter or igniter/sensor
- 3 Prepare a short jumper lead, using heavily insulated wire such as ignition cable

CAUTION

In the next step, DO NOT allow fingers to touch either the stripped end of the jumper or the stud terminal. This is a very high voltage circuit and electrical shock can result.

- 1 Perform this test immediately upon energizing the system before the ignition control goes into safety lockout and interrupts the spark circuit. Touch one end of the jumper firmly to the ignition control GND terminal. (DO NOT remove the existing ground lead.) Slowly move the other end of the jumper wire toward the stud terminal on the ignition control to establish a spark.
- 2 Pull the wire away from the stud and note the length of gap at which spark discontinues.
- 3 A spark length of 1/8 in. (3mm) or more indicates satisfactory voltage output. If no arc can be established, or the maximum spark is less than 1/8 in. (3mm), and power to the ignition

12. START UP SHEET

**COMMISSIONING REPORT
AS PER I&O MANUAL AND LOCAL CODES**

CONTRACTOR NAME:DATE.....

ADDRESS:.....

.....

CITY:.....

PHONE:.....

CELL:

JOB SITE.....CITY.....

HEATER MODEL NUMBER:.....

HEATER SERIAL NUMBER:

THIS EQUIPMENT HAS BEEN FACTORY FIRED AND TESTED BEFORE DELIVERY, NEVERTHELESS IT IS NOT A PLUG IN APPLIANCE..IT DOES REQUIRE COMMISSIONING AND FIELD ADJUSTMENTS

TO ENSURE THAT SITE CONDITIONS ARE COMPATIBLE WITH THIS HEATER, AND TO ALLEVIATE NUISANCE CALL BACKS FOR THE CONTRACTOR, THE FOLLOWING START-UP NEEDS TO BE COMPLETED BY THE LICENSED GAS INSTALLER.

**A CONTRACTOR IS CALLING FOR TECHNICAL SUPPORT,
MUST PROVIDE THE FOLLOWING INFORMATION
FROM HIS COMPLETED COMMISSIONING REPORT ON NEXT PAGE**

FAX COMPLETED FORM TO TECHNICAL SERVICES: CANADA - 905-712-8336 USA - 706-554-9390

**TO BE COMPLETED BY THE LICENSED INSTALLER:
HIGH INTENSITY COMMISSIONING REPORT**

TYPE OF GAS:	NG	<input type="checkbox"/>	<input type="checkbox"/>
DOES BUILDING HAVE A NEGATIVE CONDITION:	YES	<input type="checkbox"/>	<input type="checkbox"/>
WILL HEATER BE EXPOSED TO WELDING FUMES:	YES	<input type="checkbox"/>	<input type="checkbox"/>
IS HEATER EXPOSED TO CHEMICAL OR CORROSIVE ATMOSPHERE:	YES	<input type="checkbox"/>	<input type="checkbox"/>
IS AN OPEN FLAME COMPATIBLE WITH THE INSTALLED LOCATION:	YES	<input type="checkbox"/>	<input type="checkbox"/>
MINIMUM CLEARANCES CONFORM AS PER I&O MANUAL:	YES	<input type="checkbox"/>	<input type="checkbox"/>
IF THIS IS A HIGH ALTITUDE AREA WHAT IS THE ALTITUDE ABOVE SEA LEVEL		<input type="text"/>	Feet
IS HEATER SHORT AXIS HORIZONTAL WITH THE VENTURI ON TOP:	YES	<input type="checkbox"/>	<input type="checkbox"/>
IS HEATER INTERLOCKED WITH AN EXHAUST FAN SYSTEM:	YES	<input type="checkbox"/>	<input type="checkbox"/>
IS FAN SYSTEM 3 CFM PER 1000Btu/hr OF THE TOTAL HEAT LOAD:	YES	<input type="checkbox"/>	<input type="checkbox"/>
WILL HEATER BE AFFECTED BY OVERHEAD CRANES / VIBRATION:	YES	<input type="checkbox"/>	<input type="checkbox"/>
IS GAS SUPPLY LINE ADEQUATELY SIZED FOR SYSTEM VOLUME:	YES	<input type="checkbox"/>	<input type="checkbox"/>
HAVE GAS LINES AND BRANCHES BEEN PURGED OF AIR:	YES	<input type="checkbox"/>	<input type="checkbox"/>
THIS HEATER WAS FIELD TEST FIRED WITHOUT ANY MALFUNCTION:	YES	<input type="checkbox"/>	<input type="checkbox"/>
INLET GAS SUPPLY PRESSURE WITH HEATER OPERATING:		<input type="text"/>	WC"
GAS VALVE OUTLET (Manifold) PRESSURE WITH HEATER OPERATING:		<input type="text"/>	WC"
HAS THE WIRING POLARITY BEEN MAINTAINED THROUGHOUT:	YES	<input type="checkbox"/>	<input type="checkbox"/>
WHAT IS THE VOLTAGE READING AT THE IGNITION MODULE:		<input type="text"/>	VOLTS
WHAT IS THE FLAME SIGNAL STRENGTH IN uA FROM SENSOR:		<input type="text"/>	uA (microamps)
IS THE HEATER CONTROLLED BY A THERMOSTAT:	YES	<input type="checkbox"/>	<input type="checkbox"/>
IS THE THERMOSTAT STRATEGICALLY LOCATED:	YES	<input type="checkbox"/>	<input type="checkbox"/>
TOTAL HEATERS SUPPLIED FROM ONE SINGLE TRANSFORMER:		<input type="text"/>	TOTAL
WHAT IS THE RATING OF THE TRANSFORMER IN VA:		<input type="text"/>	V.A.
WHAT IS THE TOTAL LENGTH OF THE LOW VOLTAGE WIRING:		<input type="text"/>	FEET
WHAT IS THE GAUGE OF THE LOW VOLTAGE WIRING:		<input type="text"/>	GAUGE

THIS HEATER MUST HAVE GOOD ELECTRICAL GROUNDING:

* FAX COMPLETED FORM TO TECHNICAL SERVICES: CANADA - 905-712-8336 USA - 706-554-9390

13. OPTIONAL COMPONENTS

Line Voltage Thermostat



PART #

JL-0772-XX

TruTemp Thermostat



JM-0150-XX

FOR SECURITY TO PREVENT UNAUTHORIZED OPENING:

2 - Stainless Steel Tamper Proof Screws for TruTemp Thermostat, including 1 Tool. (only one Tool is necessary per project.)

JM-0180-XX

2 - Stainless Steel Tamper Proof Screws for TruTemp Thermostat.

JM-0180-AA

Low Voltage Thermostat (24 Volts)



JS-0569-XX

Flexible Gas connector 1/2" x 18"



JL-0771-FF

Pressure Equalizer Venturi Cover

JO-0368-XX

Control Protector Cover

JO-0366-XX

Transformer Relay

JM-0300-XX

AT72D-40VA Transformer



JL-0776-XX

100 VA Transformer

JL-0778-XX

150 VA Transformer

JL-0779-XX

200 VA Transformer

JL-0780-XX

250 VA Transformer

JL-0781-XX

350 VA Transformer

JL-0781-AA

500 VA Transformer

JL-0781-BB



FANS AND MOTORS USED IN CONJUNCTION WITH SERIES HIGH INTENSITY HEATERS.

WALL EXHAUSTER

Price includes fan, motor, drive kit, air proving switch and wall mounting kit.

CAPACITY CFM*

600 CFM
900 CFM
1200 CFM
1500 CFM
1800 CFM
2100 CFM
2400 CFM
2700 CFM
3000 CFM
3300 CFM

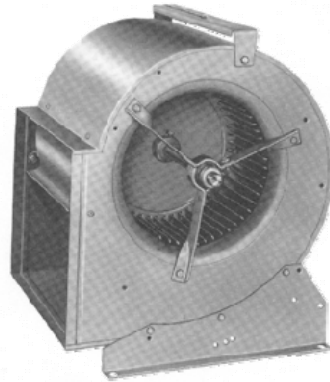

PART #

JL-0870-KT
JL-0871-KT
JL-0872-KT
JL-0873-KT
JL-0874-KT
JL-0875-KT
JL-0876-KT
JL-0877-KT
JL-0878-KT
JL-0879-KT

ROOF EXHAUSTER

Price includes weatherproof cabinet with ½" fiberglass lining, intake bird screen, aluminum back draft damper, removable access panel, drive kit, motor, recessed bottom for curb mounting, (curb not included) air proving switch.

CAPACITY CFM*

600 CFM
900 CFM
1200 CFM
1500 CFM
1800 CFM
2100 CFM
2400 CFM
2700 CFM
3000 CFM
3300 CFM

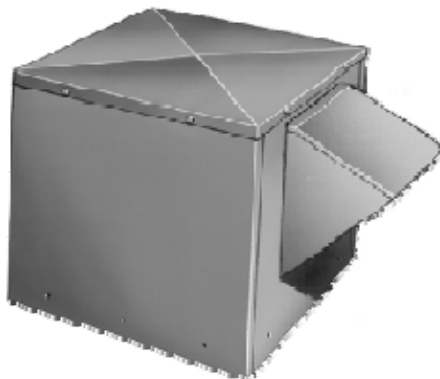

JL-0880-KT
JL-0881-KT
JL-0882-KT
JL-0883-KT
JL-0884-KT
JL-0885-KT
JL-0886-KT
JL-0887-KT
JL-0888-KT
JL-0889-KT

*Gas code requires 300 CFM of indirect exhaust for every 100,000 BTU of unvented heaters installed. The exhauster and heaters must be interlocked with an air proving switch.



GAS-FIRED INFRA-RED LUMINOUS SERIES: PRIMOSCHWANK / SUPRASCHWANK

The Manufacturer warrants that this product is free from defects in material or workmanship under normal use and service subject to the terms of this document.

FIVE YEAR WARRANTY

Subject to the conditions and limitations stated herein, during the term of this limited warranty, we will supply any component part (at our option a new or repaired component part) of the heater, as defined below, excluding any labor, which the Manufacturer's examination determines to be defective in workmanship or material for a period of five years (5 years) from the date of installation, unless otherwise specified below. This warranty applies to the heater's original owner, and subsequent transferees and only if the unit is installed and operated in accordance with the printed instructions accompanying the unit and in compliance with all applicable installation, building codes and good trade practices. Warranty is only applicable to Schwank components, other parts are limited to their own Manufacturers' warranty. (1 year)

FIFTEEN YEAR WARRANTY

The Manufacturer warrants the Ceramic Tiles for a period of fifteen years (15 years)

WHAT IS NOT COVERED

This warranty does not cover heating products improperly installed, misused, exposed to or damaged by negligence, accident, corrosive or contaminating atmosphere, water, excessive thermal shock, impact, abrasion, alteration or operation contrary to the owner's manual or if the serial number has been altered, defaced or removed. This warranty shall not apply if the input to the heating product exceeds by more than 2% of the rated input on the rating plate. The Manufacturer shall not be responsible for any expenses, including service, labor, diagnosis, analysis, material or transportation charges incurred during removal or reinstallation of this product, or any of its components or parts. All labor or service charges shall be paid by the owner. The Manufacturer shall not be liable for any default or delay in performance by its warranty caused by any contingency beyond its control, including war, government restrictions, or restraints, strikes, fire, flood, acts of God, or short or reduced supply of raw materials or products.

WARRANTY PROCEDURE

To establish the installation date for any purpose under this Limited Warranty, you must retain the original records that can establish the installation date of your unit. If you do not provide such documents, the start date of the term of this Limited Warranty will be based upon the date of unit manufacture, plus thirty (30) days. Failure to maintain the equipment through regular annual service maintenance by a qualified service technician shall void the warranty.

LIMITATIONS AND EXCLUSIONS

This document contains all warranties made by the Manufacturer and may not be varied, altered or extended by any person. There are no promises, or agreements extending from the Manufacture other than the statements contained herein. **THIS WARRANTY IS IN LIEU OF ALL WARRANTIES EXPRESSED OR IMPLIED, TO THE EXTENT AUTHORIZED BY THE LAWS OF THE JURISDICTION, INCLUDING SPECIFICALLY THE WARRANTIES OR MERCHANTABILITY OF FITNESS FOR A PARTICULAR PURPOSE.**

It is understood and agreed that the Manufacturer's obligation hereunder is limited to repairing or replacing parts determined to be defective as stated above. In no event shall the Manufacturer be responsible for any alleged personal injuries or other special, incidental or consequential damages. As to property damages, contract, tort or other claim the Manufacturer's responsibility shall not exceed the purchase priced paid for the product.

All replacement parts will be warranted for the unused portion of the warranty coverage period remaining on the applicable unit.

Some Authorities do not allow certain warranty exclusions or limitations on how long a warranty lasts or the exclusions or limitations of incidental or consequential damages. In such cases, the above limitations or exclusions may not apply to you and are not intended to do so where prohibited by law. This warranty gives you specific legal rights. You may also have other rights which vary by each jurisdiction.

SCHWANK 5285 BRADCO BLVD. MISSISSAUGA, ON, L4W 2A6 Ph: 905-7121-4766

SP-DSUA-BX-03B
PRIMO-SUPRA WARRANTY
March 2006
RL: 3B
KH