



Radio / DAB / CD / SD/MMC / MP3

Nashville DAB35

7 645 660 310

Operating instructions



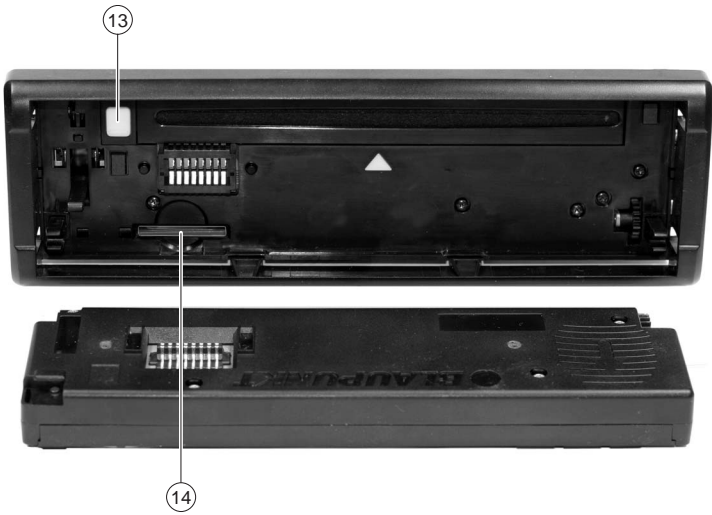

<http://www.blaupunkt.com>

 **BLAUPUNKT**



CONTROLS

- ① Button to switch the device on/off and operate the volume mute feature.
- ②  button to open the flip-release control panel.
- ③ Volume control.
- ④ **BND•TS** button.
Short press: Selects the FM memory banks and the MW and LW wavebands, selects the DAB memory bank.
Long press: Starts the FM Travelstore function and the DAB Travelstore function.
- ⑤ **DIS•ESC** button to change the display content and close menus without saving changes.
- ⑥ Arrow buttons.
- ⑦ **MENU•OK** button
Short press: Calls up the menus for basic settings and confirms menu entries.
Long press: Starts the scan function.
- ⑧ **TRAF** button to switch traffic information standby on/off.
- ⑨ **REC•DEL** button.
Short press: Starts a recording from DAB to MMC.
Long press: Deletes the current title in MMC mode.
- ⑩ Buttons **1 - 5**.
- ⑪ **AUD•DEQ** button (Audio).
Short press: Sets bass, treble, balance and fader.
Long press: Opens the equalizer menu.
- ⑫ **SRC** button to switch sources between CD/MP3, SD/MMC, CD changer (if connected) and AUX.
- ⑬ , button to eject the CD from the device.
- ⑭ Slot for SD/MMC or KeyCard.

Notes and accessories	69	DAB sub-programmes	84
Road safety	69	DAB radio text	85
Installation	69	Setting the length of the programme names	85
Installations	69	Changing the display	85
Activating/deactivating demo mode .	70	Radio mode	86
Detachable control panel and KeyCard	70	Switching to radio mode	86
Theft protection	70	Convenient RDS functions (AF, REG)	86
Detaching the control panel	71	Selecting the waveband/ memory bank	87
Attaching the control panel	71	Tuning into a station	87
Keycard	71	Setting the sensitivity of station seek tuning	88
Keycard Damaged or Lost	72	Storing stations	88
Looking after the KeyCard	73	Storing stations automatically (Travelstore)	88
Switching on/off	74	Listening to stored stations	89
Adjusting the volume	74	Scanning receivable stations (SCAN)	89
Setting the power-on volume	74	Setting the scanning time	89
Quickly reducing the volume (Mute)	75	Programme type (PTY)	89
Telephone audio/navigation audio ...	75	Optimising radio reception	91
Setting the volume of the confirmation beep	76	SHARX	91
Automatic sound	76	Configuring the display	92
DAB mode	77	Activating/deactivating the radio text display	92
Switching to DAB mode	77	Traffic information	93
Switching regional traffic announcements on/off (DAB TREG)	79	CD mode	94
Selecting the memory bank	80	Switching to CD mode	94
Tuning into ensembles	80	Selecting tracks	95
Selecting programmes	81	Fast track selection	95
Scanning receivable DAB programmes (DAB-SCAN)	81	Fast searching (audible)	95
Storing programmes	81	Random track play (MIX)	95
Accessing stored programmes	82	Scanning tracks (SCAN)	95
DAB programme type (PTY)	82	Repeating tracks (REPEAT)	96
Setting the DAB waveband	83	Changing the display	96
Switching between DAB and FM .	83	Displaying CD text/CD name	96
DAB Service following	84	Naming CDs	97

CONTENTS

Traffic announcements in CD mode	99	Playing recordings using the device	112
Ejecting a CD	99	Formatting SDs/MMCs	113
MP3 mode	99	Configuring the display	114
Preparing an MP3 CD	99	Programming your favourite tracks for an SD/MMC	114
Switching to MP3 mode	101	Switching pre-record on/off	114
Configuring the display	101	CD-changer mode	115
Selecting a directory	101	Switching to CD-changer mode .	115
Selecting tracks	102	Selecting CDs	115
Fast searching (not in MP3 browse mode)	102	Selecting tracks	115
Random track play – MIX (not in MP3 browse mode)	103	Fast searching (audible)	115
Scanning tracks – SCAN (not in MP3 browse mode)	103	Changing the display	115
Repeating individual tracks or whole directories – REPEAT (not in MP3 browse mode)	103	Repeating individual tracks or whole CDs (REPEAT)	116
Programming your favourite tracks on an MP3 CD	104	Random track play (MIX)	116
SD/MMC mode	105	Scanning all tracks on all CDs (SCAN)	116
Inserting/removing SDs/MMCs..	105	Naming CDs	117
Switching to SD/MMC mode	106	CLOCK time	118
Configuring the display	106	Sound	120
Selecting a directory	106	X-BASS	121
Selecting tracks	107	Equalizer	121
Fast searching (not in MP3 browse mode)	108	Adjusting the display settings	125
Random track play – MIX (not in MP3 browse mode)	108	External audio sources	126
Scanning tracks – SCAN (not in MP3 browse mode)	108	Amplifier	127
Repeating individual tracks or whole directories – REPEAT (not in MP3 browse mode)	108	TMC for dynamic navigation systems	127
Recording DAB programmes onto SDs/MMCs	109	Specifications	128
Making a timer-controlled recording of a DAB programme .	111		

Notes and accessories

Thank you for choosing a Blaupunkt product. We hope you enjoy using this new piece of equipment.

Please read these operating instructions before using the equipment for the first time.

The Blaupunkt editors are constantly working on making the operating instructions clearer and easier to understand. However, if you still have any questions on how to operate the device, please contact your dealer or the telephone hotline for your country. You will find the telephone number printed at the back of this booklet.

We provide a manufacturer guarantee for our products bought within the European Union. You can view the guarantee conditions at www.blaupunkt.de or ask for them directly at:

Blaupunkt GmbH

Hotline

Robert Bosch Str. 200

31139 Hildesheim Germany

Road safety

 Road safety has absolute priority. Only operate your car sound system if the road and traffic conditions allow you to do so. Familiarise yourself with the device before setting off on your journey. You should always be able to hear police, fire and ambulance sirens in good time from inside your vehicle. For this reason, listen to your car sound system at a suitable volume level during your journey.

Installation

If you want to install your car sound system yourself, please read the installation and connection instructions that follow these operating instructions.

Installations

Use only accessories approved by Blaupunkt.

DAB antenna

You need a special DAB antenna in order to operate the Nashville DAB 35. This can be a separate DAB roof/window antenna or a DAB/AM/FM combination antenna. You can obtain further information from your Blaupunkt dealer.

Remote control

The RC 08, RC 10, RC 10 H or RC 12 H (available as optional accessories) remote control can be used to safely and conveniently perform most of the basic functions of your car sound system.

You cannot switch the device on/off using the remote control.

Amplifiers

You can use all Blaupunkt and Velocity amplifiers.

CD changers

You can connect the following Blaupunkt CD changers:
CDC A 08, IDC A 09 and CDC A 03.

Activating/deactivating demo mode

You can activate the so-called demo mode at the device. In demo mode, the different functions of the device are displayed as scrolling text.

⇒ Press the **MENU•OK** button (7).

The display shows the menu.

⇒ Press and hold the **MENU•OK** button (7) pressed for more than four seconds while the menu is displayed to activate or deactivate the demo mode.

Time-out (time window)

The device features a time-out function (time window).

For example, if you press the **MENU•OK** button (7) and select a menu item, the device switches back after approx. 16 seconds after the last button activation. The settings performed are saved.

Detachable control panel and KeyCard

Theft protection

The device is equipped with a detachable control panel (flip-release panel) as a way of protecting your equipment against theft. The device is worthless to a thief without this control panel.

Protect your device against theft by taking the control panel with you whenever you leave your vehicle. Do not leave the control panel inside your vehicle – not even in a hiding place.

The control panel has been designed to be easy to use.

Notes:

- Never drop the control panel.
- Never expose the control panel to direct sunlight or other heat sources.
- Avoid direct skin contact with the control panel's electrical contacts. If necessary, clean the contacts with a lint-free cloth moistened with cleaning alcohol.

Detaching the control panel

- ⇨ Press the  button (2).

The control panel opens out towards you.

- ⇨ Hold the control panel by its right side and then pull the control panel straight out of the bracket.

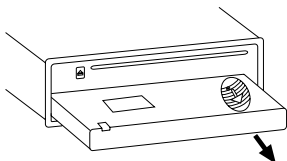

Notes:

- All the current settings are saved.
- Any CD already inserted in the device remains there.
- The device switches off automatically after approx. one minute.

Attaching the control panel

- ⇨ Hold the control panel at approximately right angles to the device.
- ⇨ Slide the control panel into the device's guides that are positioned on the left and right at the lower edge of the housing. Push the control panel carefully into the bracket until it clicks into place.
- ⇨ Flip up the control panel and carefully press it into the device until it clicks into place.

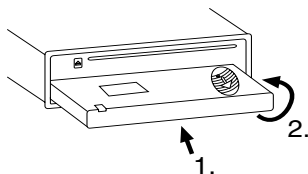

Note:

- When attaching the control panel, make sure you do not press the display.

If the device was still switched on when you detached the control panel, it will automatically switch on with the last setting activated (radio, CD/MP3, SD/MMC, CD changer or AUX) when the panel is replaced.

Keycard

In addition to the removable control unit, your car radio is protected by a keycard.

The keycard is required when you use the unit for the first time. Afterwards you only need the keycard if the unit has been disconnected from the vehicle power supply.

Note:

- Please remove the keycard from the unit after using it for the first time.
Without the keycard, the car radio is worthless for thieves.
- Key the keycard in a safe place, but not in the car.
- If you will be on the road for an extended period (e.g., vacation), then take along the keycard so

CONTROL PANEL/KEYCARD

that you can restart the car radio if necessary after it has been disconnected from the vehicle power supply.

Inserting the KeyCard

To insert the KeyCard in the device,

- ⇨ detach the detachable control panel as described in the section entitled “Detaching the control panel”.

The slot for the KeyCard is located behind the control panel ⁽¹⁴⁾.

- ⇨ Carefully insert the KeyCard (with its contacts facing downwards and its bevelled edge pointing to the right) into the slot until you feel it click into place.
- ⇨ Attach the control panel again as described in “Attaching the control panel”.

“KEYCARD OK” appears briefly on the display.

Removing the KeyCard

To remove the KeyCard from the device,

- ⇨ detach the detachable control panel as described in the section entitled “Detaching the control panel”.

The slot for the KeyCard is located behind the control panel ⁽¹⁴⁾.

- ⇨ Push against the KeyCard until you feel it unlatch.

The KeyCard is ejected.

- ⇨ Carefully pull the KeyCard out of the slot.
- ⇨ Attach the control panel again as described in “Attaching the control panel”.

Keycard Damaged or Lost

After the unit has been disconnected from the power supply, you will need the keycard that belongs to your unit.

If the keycard is damaged or you have lost it, then you need a new keycard.

You can acquire a new keycard at your Blaupunkt dealer’s.

In order to use the new keycard, you need the master code for your unit.

For security reasons, the master code is obtainable only from your Blaupunkt dealer or through Blaupunkt customer service upon presentation of proof of ownership.

Note:

- In order to determine the master code, your Blaupunkt dealer or Blaupunkt customer service will need the model number and serial number of your Blaupunkt unit. The model no. and serial no. are found on the right side of the unit.
- In order to have the numbers on hand without having to uninstall the unit, please enter these in the car radio passport on the last page of these instructions for use before installation of the unit.

“Training” a New Keycard/Entering the Master Code

If you have acquired a new keycard, then you must first “train” it.

- ⇨ Turn off the unit.
- ⇨ Insert the new keycard that is unknown to the unit.
- ⇨ Close the control unit.
- ⇨ Simultaneously press and hold down the **BND•TS** button (4) and the **1 MIX** button (10).
- ⇨ Switch on the device by pressing button (1).

“0000 MASTERCODE” appears on the display.

Enter the four-digit master code that is printed on the car radio passport as follows:

- ⇨ Press the **V** or **^** button (6) repeatedly until the first digit of the master code appears on the display.
- ⇨ Press the **>** button (6) to change the input position.
- ⇨ Press the **V** or **^** button (6) repeatedly until the second digit of the master code appears on the display. Then proceed in the same way for all the digits of the master code.
- ⇨ If the master code is displayed correctly, press the **MENU•OK** button (7).

The new KeyCard is accepted as soon as the device switches to playback mode and “KEYCARD OK” appears briefly on the display.

Note:

- If you entered the master code incorrectly three times, you must wait for one hour. During this waiting period, “WAIT 1H” will appear on the display and the device cannot be operated. **Do not** switch off the device during this period. After the hour has elapsed enter the correct master code.

Looking after the KeyCard

Keeping the contacts free from dirt and other particles will ensure that the KeyCard functions properly. Avoid making direct skin contact with the contacts.

If necessary, clean the contacts of the KeyCard with a lint-free cloth moistened with cleaning alcohol.

Switching on/off

There are various ways of switching the device on/off:

Switching on/off using the vehicle ignition

The device will switch on/off simultaneously with the ignition if the device is correctly connected to the vehicle's ignition and you did not switch the device off by pressing button ①.

Switching the device on/off using the detachable control panel

⇨ Detach the control panel.

The device switches off automatically after approx. one minute.

⇨ Attach the control panel again.

The device switches on. The last setting (radio, CD/MP3, SD/MMC, CD changer or AUX) will be reactivated.

Switching on/off using button ①

⇨ To switch on the device, press button ①.

⇨ To switch off the device, press and hold down button ① for longer than two seconds.

The device switches off.

Note:

- To protect the vehicle battery, the device will switch off automatically after one hour if the ignition is off.

Adjusting the volume

Note:

- The internal amplifier can be switched off. If the loudspeakers do not emit any sound, please read the section entitled "Switching the internal amplifier on/off" in the "Amplifier" chapter.

You can adjust the volume in steps from 0 (off) to 50 (maximum).

To increase the volume,

- ⇨ turn the volume control ③ clockwise.

To decrease the volume,

- ⇨ turn the volume control ③ anticlockwise.

Setting the power-on volume

You can set the default volume level at which the device plays when it is switched on.

⇨ Press the **MENU•OK** button ⑦.

⇨ Press the **V** or **Λ** button ⑥ repeatedly until "VOLUME" appears on the display.

⇨ Press the **MENU•OK** button ⑦ to display the volume menu.

"ON VOLUME" and the currently set value are displayed or "LAST VOLUME" is displayed.

⇨ Adjust the power-on volume using the **<>** buttons ⑥.

To help you adjust the setting more easily, the device will increase or decrease the volume as you make your changes.

If you change the setting to “LAST VOLUME”, the volume when the device switches on will be the same as the volume level that was set the last time you switched the device off.

Danger to hearing!

If the power-on volume is set to maximum, the volume level can be very high when the device is switched on.

If the volume was set to maximum before the device was switched off and the power-on volume is set to “LAST VOLUME”, the volume level can be very high when the device is switched on again.

Severe damage to your hearing can be caused in both cases!

When you have finished making your changes,

- ⇨ press the **MENU•OK** button  and then the **DIS•ESC** button  to exit the menu.

Quickly reducing the volume (Mute)

You can quickly reduce the volume to a preset level (Mute).

- ⇨ **Briefly** press button .

“MUTE” appears on the display.

Cancelling mute

To return to your previously set volume level,

- ⇨ **briefly** press button  again.

Telephone audio/navigation audio



If your car sound system is connected to a mobile telephone or a navigation system, the sound system’s volume will be muted as soon as you “pick up” the phone or as soon as a navigation announcement is made. You will then hear the caller or navigation announcement over the car sound system’s loudspeakers. In order for this feature to work, the mobile telephone or navigation system must be connected to the car sound system as described in the installation instructions.

You will need a cable for this with the following Blaupunkt number: 7 607 001 503.

You can find out from your Blaupunkt dealer which navigation systems can be used with your car sound system.

If the sound system receives a traffic announcement during a telephone call or whilst a navigation announcement is being made, you will only be able to hear the traffic announcement after the call or navigation announcement is finished (in so far as the traffic announcement is still being broadcast). The traffic announcement is not recorded!

The volume with which telephone calls or navigation announcements are broadcast can be adjusted.

- ⇨ Press the **MENU•OK** button .
- ⇨ Press the **V** or **Λ** button  repeatedly until “VOLUME MENU” appears on the display.

ADJUSTING THE VOLUME

- ⇨ Press the **MENU•OK** button (7) to display the volume menu.
- ⇨ Press the **V** or **Λ** button (6) repeatedly until "PHONE/NAVI" appears on the display.
- ⇨ Set your preferred volume level using the **<>** buttons (6).

When you have finished making your changes,

- ⇨ press the **MENU•OK** button (7) and then the **DIS•ESC** button (5) to exit the menu.

Note:

- You can use the volume control (3) to adjust the volume of telephone calls and navigation announcements whilst you are listening to them.

Setting the volume of the confirmation beep

The system will output a confirmation beep for some functions if you keep a button pressed down for longer than two seconds, for instance, when assigning a radio station to a station preset button. You can adjust the volume of this beep.

- ⇨ Press the **MENU•OK** button (7).
- ⇨ Press the **V** or **Λ** button (6) repeatedly until "VOLUME MENU" appears on the display.
- ⇨ Press the **MENU•OK** button (7) to display the volume menu.
- ⇨ Press the **V** or **Λ** button (6) repeatedly until "BEEP VOL" appears on the display.

- ⇨ Adjust the volume using the **<>** buttons (6). "0" means that the beep is deactivated, "6" means that the maximum beep volume is set.

When you have finished making your changes,

- ⇨ press the **MENU•OK** button (7) and then the **DIS•ESC** button (5) to exit the menu.

Automatic sound

This feature automatically adjusts the volume of the car sound system to suit the speed at which the vehicle is travelling. In order for this to work, your car sound system must be connected as described in the installation instructions.

You can adjust the automatic volume boost feature in six steps from (0 to 5).

- ⇨ Press the **MENU•OK** button (7).
- ⇨ Press the **V** button (6) repeatedly until "VOLUME MENU" appears on the display.
- ⇨ Press the **MENU•OK** button (7) to display the volume menu.
- ⇨ Press the **V** or **Λ** button (6) repeatedly until "AUTO SOUND" appears on the display.
- ⇨ Set the volume adjustment level using the **<>** buttons (6).

When you have finished making your changes,

- ⇨ press the **MENU•OK** button (7) and then the **DIS•ESC** button (5) to exit the menu.

Note:

- The optimum setting for the speed-dependent volume adjustment feature depends on how noise levels develop in your particular vehicle. You will need to test various settings in order to find out which is best suited to your vehicle.

DAB mode

You can enjoy radio in digital audio quality thanks to DAB (**D**igital **A**udio **B**roadcast).

Note:

- You need a special DAB antenna in order to operate the Nashville DAB 35. This can be a separate DAB roof/window antenna or a DAB/AM/FM combination antenna. You can obtain further information from your Blaupunkt dealer.

Switching to DAB mode

If you are in Radio, CD/MP3, SD/MMC, CD-changer or AUX mode,

- ⇨ press the **SRC** button (12) repeatedly until “DAB” appears on the display.

In contrast with standard radio broadcasting, several programmes are always broadcast over the same frequency for DAB. These programmes are arranged in “**ensembles**”. An ensemble always contains several programmes.

In turn, a programme can additionally contain up to twelve **sub-programmes**. In the case of a sports station, for instance, various sports events can be broadcast simultaneously as sub-programmes. If a programme has sub-programmes, you will see a “★” displayed in front of the programme name.

DAB MODE

DAB also offers further advantages:

NEWS

News reports (NEWS) are provided in addition to the traffic announcements. If you wish, you can allow the news reports to be played. If the "DAB NEWS ON" setting is activated, the current programme will be interrupted when a news report arrives, and the report will be played. At the end of the news report, the radio returns to the programme that you were listening to before.

- ⇒ Press the **MENU•OK** button (7).
- ⇒ Press the **MENU•OK** button (7), to display the DAB menu.
- ⇒ Press the **V** or **^** button (6) repeatedly until "DAB NEWS ON" or "DAB NEWS OFF" appears on the display.

If you want to receive news reports, select "DAB NEWS ON". If you do not want to listen to news reports, select "DAB NEWS OFF".

- ⇒ Select the setting that you want using the **<>** buttons (6).

When you have finished making your changes,

- ⇒ press the **MENU•OK** button (7) and then the **DIS•ESC** button (5) to exit the menu.

WEATHER

Weather reports (WEATHER) are provided in addition to the traffic announcements. If you wish, you can allow the weather reports to be played. If the "DAB WEAT ON" setting is activated, the current programme will be interrupted when a weather report arrives, and the report will be played. At the end of the weather report, the radio returns to the programme that you were listening to before.

- ⇒ Press the **MENU•OK** button (7).
- ⇒ Press the **MENU•OK** button (7), to display the DAB menu.
- ⇒ Press the **V** or **^** button (6) repeatedly until "DAB WEATHER OFF" or "DAB WEATHER ON" appears on the display.

If you want to receive weather reports, select "DAB WEAT ON". If you do not want to listen to weather reports, select "DAB WEAT OFF".

- ⇒ Select the setting that you want using the **<>** buttons (6).

When you have finished making your changes,

- ⇒ press the **MENU•OK** button (7) and then the **DIS•ESC** button (5) to exit the menu.

SPORT

Sports reports are provided in addition to the traffic announcements, news reports and weather reports. If you wish, you can allow the sports reports to be played. If the "DAB SPORT ON" setting is activated, the current programme will be interrupted when a sports report arrives, and the report will be played. At the end of the news report, the radio returns to the programme that you were listening to before.

- ⇨ Press the **MENU•OK** button (7).
- ⇨ Press the **MENU•OK** button (7), to display the DAB menu.
- ⇨ Press the **V** or **Λ** button (6) repeatedly until "DAB SPORT ON" or "DAB SPORT OFF" appears on the display.

If you want to receive sports reports, select "DAB SPORT ON". If you do not want to listen to sports reports, select "DAB SPORT OFF".

- ⇨ Select the setting that you want using the **<>** buttons (6).

When you have finished making your changes,

- ⇨ press the **MENU•OK** button (7) and then the **DIS•ESC** button (5) to exit the menu.

Note:

- You can interrupt a news, weather or sports report whilst it is being played by pressing the **TRAF** button (8). The general priority settings are retained and the next report will be played when it arrives.

Switching regional traffic announcements on/off (DAB TREG)

Since DAB frequencies are broadcast over a large area of the country, the situation might arise in which you receive traffic announcements that are not relevant to your region.

In order to avoid this, the DAB transmitter service areas are divided into regions.

- ⇨ Press the **MENU•OK** button (7).
- ⇨ Press the **MENU•OK** button (7), to display the DAB menu.
- ⇨ Press the **V** or **Λ** button (6) repeatedly until "DAB TREG OFF" or "DAB TREG ON" appears on the display.

If you want to receive announcements that apply to specific regions, select "DAB TREG ON". If you only want to receive non-regional announcements, select "DAB TREG OFF".

- ⇨ Select the setting that you want using the **<>** buttons (6).

When you have finished making your changes,

- ⇨ press the **MENU•OK** button (7) and then the **DIS•ESC** button (5) to exit the menu.

Note:

- Since this function is not supported by all broadcasters, it is possible that you will not receive any traffic announcements if the TA-REG function is activated. If you do not receive any traffic

DAB MODE

announcements over an extended period of time, please deactivate the TA-REG function.

Selecting the memory bank

This device lets you store DAB programmes in four memory banks (D1, D2, D3 and DT).

Five programmes can be stored in each memory bank.

- ⇨ Briefly press the **BND•TS** button  to switch between the memory banks.

Notes:

- If there are no programmes stored in the DT memory bank yet, this memory bank will not be displayed. In this case, first start a Travelstore (see “Storing programmes”).
- You cannot select the DT memory bank if the PTY function is activated.

Tuning into ensembles

With DAB, several programmes broadcasted over the same frequency are always combined into an “ensemble”.

Note:

- Since various programmes from different ensembles are stored automatically in the DT memory bank, you cannot use the functions described here for tuning into an ensemble whilst the DT memory bank is activated.

Selecting an ensemble

You can directly select ensembles that you have received once already (for this to work, the ensemble must be receivable).

- ⇨ Briefly press the **▲** or **▼** button .

The name of the next or previous known ensemble is displayed. The first available programme in the ensemble is played.

Ensemble seek tuning



You can find new ensembles using seek tuning.

- ⇨ For seek tuning downwards or upwards, press and hold down the **▼** or **▲** button  for longer than two seconds.

The radio tunes into the next receivable ensemble. The ensemble name is displayed briefly. The first available programme in the ensemble is played.

Manually tuning an ensemble

You can also tune into ensembles manually.

- ⇨ Press the **<** or **>** button  during seek tuning.
- ⇨ You can now tune the radio manually using the **<** or **>** button .

Selecting programmes

After you have tuned into an ensemble, you can select a programme from the ensemble.

- ⇨ Select a programme from the ensemble using the <> buttons (6).

Scanning receivable DAB programmes (DAB-SCAN)

You can use the scan function to play all the receivable programmes briefly.

Starting DAB-SCAN

- ⇨ In DAB mode, press and hold down the **MENU•OK** button (7) for longer than two seconds.

Note:

- You cannot use the DAB scan function whilst the DT memory bank is activated.

Scanning begins. The name of the current programme appears in the top line and the name of the current ensemble appears in the bottom line. "SCANNING..." appears on the display whilst the radio switches to the next ensemble.

Stopping DAB-SCAN and continuing listening to a programme

- ⇨ Press the **MENU•OK** button (7).

Scanning stops and the radio continues playing the programme that it tuned into last. If you cancel the DAB-SCAN whilst "SCANNING..." is being displayed, the radio will retune to the programme you were listening to last.

Storing programmes

Storing programmes manually

- ⇨ Select the memory bank that you want.
- ⇨ Tune into the ensemble that you want.
- ⇨ Select the programme that you want to store.
- ⇨ Press and hold down one of the station buttons **1 - 5** (10) for longer than two seconds to assign the programme to that button.

Storing programmes automatically (Travelstore)

The Travelstore function stores the first five receivable programmes in alphabetical order and you can access them directly using the station buttons. All the other programmes that were stored in the "DT" memory bank during the Travelstore scan can be accessed alphabetically by pressing the <> ^ v (6) buttons. You can switch rapidly between the programmes if you press and hold down the ^ v buttons (6) for longer than two seconds.

Notes:

- Any programmes that were previously stored in this memory bank are deleted in the process.
- You cannot use the DAB Travelstore feature if the PTY function is activated.
- ⇨ Press and hold down the **BND•TS** button (4) for longer than two seconds.

DAB MODE

The storing procedure begins. "TRAVELSTORE PLEASE WAIT" appears on the display. After the process is completed, the programme that is stored in location 1 of the "DT" memory bank will be played. "NO LIST" appears on the display if no programmes were found during the Travelstore scan.

Accessing stored programmes

- ⇨ Select the memory bank.
- ⇨ Press the station button **1 - 5** (10).

DAB programme type (PTY)

Besides transmitting the station name, an increasing number of stations also provide information on the type of programme that they are broadcasting. Your car radio can receive and display this information.

For example, the programme types can be:

CULTURE	TRAVEL	JAZZ
SPORT	NEWS	POP M
ROCK M	DRAMA	EASY M

You can use the PTY function to select stations of a particular programme type.

Switching DAB-PTY on/off

- ⇨ Press the **MENU•OK** button (7).
- ⇨ Press the **MENU•OK** button (7), to display the DAB menu.
- ⇨ Press the **V** or **^** button (6) repeatedly until "DAB PTY ON" or "DAB PTY OFF" appears on the display.

- ⇨ Press the **>** or **<** button (6) to switch DAB-PTY ON or OFF.

When you have finished making your changes,

- ⇨ press the **MENU•OK** button (7) and then the **DIS•ESC** button (5) to exit the menu.

Selecting a programme type and starting seek tuning

- ⇨ Press the **<** or **>** button (6).

The current programme type appears briefly on the display. If you do not make a selection whilst this display is visible, the normal DAB display will be used again.

- ⇨ If you want to select another programme type, you can do so by pressing the **<** or **>** button (6) whilst this display is visible.

Or

- ⇨ Press one of the buttons **1 - 5** (10) to select a programme type that is assigned to one of these buttons.

The selected programme type appears briefly on the display.

- ⇨ Press the **V** or **^** button (6) to start seek tuning.

The radio will then tune into the next station that it finds that corresponds to your selected programme type.

Assigning a programme type to a station button

- ⇨ Select a programme type using the **<** or **>** button (6).

- ⇨ Press and hold the desired station button **1 - 5** (10) for longer than two seconds.

The programme type is stored on the selected button **1 - 5** (10).

Setting the DAB waveband

With the Nashville DAB35, you can receive DAB programmes and ensembles on the following wavebands: "Band 3" (174 - 240 MHz) and "L-Band" (1452 - 1491 MHz). Since some countries do not use both wavebands, you can speed up seek tuning by excluding the waveband that is not supported.

- ⇨ Press the **MENU•OK** button (7).
- ⇨ Press the **MENU•OK** button (7), to display the DAB menu.
- ⇨ Press the **V** or **^** button (6) repeatedly until "DAB-BAND L", "DAB-BAND 3" or "DAB-BAND BOTH" appears on the display.
- ⇨ Press the **<** or **>** button (6) to switch between the settings.

If "DAB-BAND L" or "DAB-BAND 3" is set, only the selected waveband will be used. If "DAB-BAND BOTH" is set, both wavebands will be used.

When you have finished making your changes,

- ⇨ press the **MENU•OK** button (7) and then the **DIS•ESC** button (5) to exit the menu.

Switching between DAB and FM

You can select various settings for switching between DAB and FM radio mode. It might be necessary to switch between DAB and FM radio if the DAB or FM reception quality decreases severely.

If you select the "DAB-FM-AUTO" setting, the device automatically tunes into the FM frequency of the programme currently being received (if the programme can be received on FM), or it tunes into the DAB programme of the FM station that is currently tuned (if the station is available as a DAB programme).

With "DAB-FM-MANUAL", the device switches to the FM frequency of the DAB programme being received if you manually call up the FM radio mode (if the programme can be received on FM).

If you set "DAB-FM OFF", the FM station that you listened to last will be played when you switch to FM radio mode (if the station can be received).

- ⇨ Press the **MENU•OK** button (7).
- ⇨ Press the **MENU•OK** button (7), to display the DAB menu.
- ⇨ Press the **V** or **^** button (6) repeatedly until "DAB-FM AUTO", "DAB-FM MANUAL" or "DAB-FM OFF" appears on the display.
- ⇨ Press the **<** or **>** button (6) to switch between the settings.

DAB MODE

When you have finished making your changes,

- ⇒ press the **MENU•OK** button (7) and then the **DIS•ESC** button (5) to exit the menu.

DAB Service following

If the reception quality of the programme being received decreases, the Nashville DAB35 can automatically tune to the programme in another ensemble (if available). For this feature to work, the “service following” function must be activated.

Switching service following on/off

To use service following,

- ⇒ Press the **MENU•OK** button (7).
- ⇒ Press the **MENU•OK** button (7), to display the DAB menu.
- ⇒ Press the **V** or **▲** button (6) repeatedly until “DAB SF ON” or “DAB SF OFF” appears on the display.
- ⇒ Press the **<** or **>** button (6) to switch between the settings.

When you have finished making your changes,

- ⇒ press the **MENU•OK** button (7) and then the **DIS•ESC** button (5) to exit the menu.

If Service following is activated, the RDS symbol is displayed during DAB mode.

Service following is deactivated when the RDS symbol disappears.

DAB sub-programmes

Some DAB programmes contain sub-programmes. Programmes that contain sub-programmes are marked with a “★” in front of the programme name. If a programme contains sub-programmes, you can tune into them.

Selecting sub-programmes

To switch between the sub-programmes of a programme that you are tuned into, you must first switch to sub-programme mode,

- ⇒ press and hold down the **>** button (6) for longer than two seconds.

SC will be displayed at the left edge of the display to indicate that you are currently in sub-programme mode.

The name of the sub-programme is displayed in the bottom display line.

To switch between the sub-programmes,

- ⇒ briefly press the **<** or **>** button (6).

The radio tunes into the next or previous sub-programme and then exits the sub-programme mode.

Note:

- Sub-programmes are so far only supported by a few broadcasters.

DAB radio text

In addition to their programmes, some stations broadcast additional information (e.g. news) as scrolling text on the display.

Note:

- Since displaying radio texts can distract you from the current road and traffic situation, we ask you kindly to deactivate the “DAB radio text” function or to use it only whilst the vehicle is stationary.
- ⇒ Press the **MENU•OK** button (7).
- ⇒ Press the **MENU•OK** button (7), to display the DAB menu.
- ⇒ Press the **V** or **^** button (6) repeatedly until “R-TXT ON” or “R-TXT OFF” appears on the display.
- ⇒ Press the **<** or **>** (6) to switch between “RADIO TXT ON” and “RADIO TXT OFF”.

When you have finished making your changes,

- ⇒ press the **MENU•OK** button (7) and then the **DIS•ESC** button (5) to exit the menu.

Setting the length of the programme names

Most programmes use programme names that are 8 characters long (as you are already familiar with from RDS). Some programmes use names that are 16 characters long, which cannot be displayed in one go. If a programme

uses names that are 16 characters long, you can either limit the name to eight characters or display the 16-character name as scrolling text.

- ⇒ Press the **MENU•OK** button (7).
- ⇒ Press the **MENU•OK** button (7), to display the DAB menu.
- ⇒ Press the **V** or **^** button (6) repeatedly until “SRV NAME 8” or “SRV NAME 16” appears on the display.
- ⇒ Press the **<** or **>** button (6) to switch between “SRV NAME 8” (8-digit display) and “SRV NAME 16” (16-digit display).

When you have finished making your changes,

- ⇒ press the **MENU•OK** button (7) and then the **DIS•ESC** button (5) to exit the menu.

Changing the display

You can choose from various display options in DAB mode:

- “NORMAL MODE”:
First line: memory bank, programme name and memory location, if available.
Second line: Ensemble name.
- “CLOCK MODE”:
First line: memory bank, programme name and memory location, if available.
Second line: Ensemble channel, clock time.

- “MINIMAL MODE”:
First line: memory bank and programme name.
- ⇒ Press the **DIS•ESC** button (5) repeatedly until the desired display mode is shown.

Radio mode

This device is equipped with an RDS radio receiver. Many of the receivable FM stations broadcast a signal that not only carries the programme but also additional information such as the station name and programme type (PTY). The station name appears on the display as soon as the tuner receives it.

Switching to radio mode

If you are in CD/MP3, SD/MMC, CD-changer or AUX mode,

⇒ press the **BND•TS** button (4).

or

⇒ press the **SRC** button (12) repeatedly until “TUNER” appears on the display.

Convenient RDS functions (AF, REG)

The convenient RDS functions AF (Alternative Frequency) and REGIONAL extend your radio’s range of functions.

- **AF:** If the RDS function is activated, the radio automatically tunes into the best receivable frequency for the station that is currently set.
- **REGIONAL:** At certain times, some radio stations divide their programme into regional programmes providing different content. You can use the REG function to prevent the car radio from switching to alternative frequencies that are transmitting different programme content.

Note:

- REGIONAL must be activated/deactivated separately in the menu.

Switching REGIONAL on/off

- ⇨ Press the **MENU•OK** button (7).
“TUNER MENU” appears on the display.
- ⇨ Press the **MENU•OK** button (7) to display the tuner menu.
- ⇨ Press the **∇** or **▲** button (6) repeatedly until “REG” appears on the display. “OFF” or “ON” is displayed alongside “REG”.
- ⇨ To switch REGIONAL on/off, press the **>** or **<** button (6).
- ⇨ Press the **MENU•OK** button (7) and then the **DIS•ESC** button (5) to exit the menu.

Switching the RDS function on/off

If you want to use the RDS functions (AF and REGIONAL),

- ⇨ press the **MENU•OK** button (7).
“TUNER MENU” appears on the display.
- ⇨ Press the **MENU•OK** button (7) to display the tuner menu.
“RDS ON” or “RDS OFF” appears on the display.
- ⇨ To switch RDS on/off, press the **>** or **<** button (6).
- ⇨ Press the **MENU•OK** button (7) and then the **DIS•ESC** button (5) to exit the menu.

The convenient RDS functions are active if the RDS appears on the display.

Selecting the waveband / memory bank

This device can receive programmes broadcast over the FM frequency range as well as the MW and LW (AM) wavebands. There are three memory banks available for the FM waveband (FM1, FM2 and FMT) and one for each of the MW and LW wavebands.

Five stations can be stored in each memory bank.

To switch between the FM memory banks (FM1, FM2 and FMT) and the MW and LW wavebands,

- ⇨ briefly press the **BND•TS** button (4).

Tuning into a station

There are various ways of tuning into a station.

Automatic station seek tuning

- ⇨ Press the **∇** or **▲** button (6).

The radio tunes into the next receivable station.

Tuning into stations manually

You can also tune into stations manually.

Note:

- You can only tune into stations manually if the RDS function is deactivated.
- ⇨ Press the **<** or **>** button (6).

RADIO MODE

Browsing through broadcasting networks (only FM)

If a radio station provides several programmes, you have the option of browsing through its so-called "broadcasting network".

Note:

- The RDS function must be activated before you can use this feature.
- ⇨ Press the < or > button (6) to switch to the next station on the broadcasting network.

Note:

- When using this feature, you will only be able to switch to stations that you have received once before already. To receive the stations, use the Scan or Travelstore function.

Setting the sensitivity of station seek tuning

You can choose whether the radio should only tune into stations providing good reception or whether it can also tune into those with a weak reception.

- ⇨ Press the **MENU•OK** button (7). "TUNER MENU" appears on the display.
- ⇨ Press the **MENU•OK** button (7) to display the tuner menu.
- ⇨ Press the **V** or **^** button (6) repeatedly until "SENS" appears on the display.

The display shows the currently set sensitivity level. "SENS HI3" means that

the tuner is set to the highest sensitivity setting. "SENS LO1" means it is set to the lowest sensitivity setting.

- ⇨ Set the sensitivity level that you want using the <> buttons (6).

When you have finished making your changes,

- ⇨ press the **MENU•OK** button (7) and then the **DIS•ESC** button (5) to exit the menu.

Note:

- You can set different sensitivity levels for FM and MW or LW (AM).

Storing stations

Storing stations manually

- ⇨ Select the memory bank that you want (FM1, FM2, FMT) or one of the wavebands (MW or LW).
- ⇨ Tune into the station that you want.
- ⇨ Press and hold down one of the station buttons **1 - 5** (10), for longer than two seconds to assign the station to that button.

Storing stations automatically (Travelstore)

You can automatically store the five stations offering the strongest reception in the region (only FM). The stations are stored in the FMT memory bank.

Note:

- Any stations that were previously stored in this memory bank are deleted in the process.

- ⇨ Press and hold down the **BND•TS** button (4) for longer than two seconds.

The storing procedure begins. "TRAVEL STORE PLEASE WAIT" appears on the display. After the process has completed, the radio will play the station that is stored in memory location 1 of the FMT memory bank.

Listening to stored stations

- ⇨ Select the memory bank or waveband.
- ⇨ Press the station button **1 - 5** (10) of the desired station.

Scanning receivable stations (SCAN)

You can use the scan function to play all the receivable stations briefly. You can set the scanning time from 5 to 30 seconds in the menu in increments of five seconds.

Starting SCAN

- ⇨ Press and hold down the **MENU•OK** button (7) for longer than two seconds.

Scanning begins. "SCAN" appears briefly on the display followed by a display of the current station name or frequency.

Cancelling SCAN and continuing listening to a station

- ⇨ Press the **MENU•OK** button (7).

Scanning stops and the radio continues playing the station that it tuned into last.

Setting the scanning time

- ⇨ Press the **MENU•OK** button (7). "TUNER MENU" appears on the display.
- ⇨ Press the **∨** or **∧** button (6) repeatedly until "VARIOUS MENU" appears on the display.
- ⇨ Press the **MENU•OK** button (7) to display the menu. "SCAN TIME" and the currently set time are displayed.
- ⇨ Set the scanning time that you want using the **<>** buttons (6).

When you have finished making your changes,

- ⇨ press the **MENU•OK** button (7) and then the **DIS•ESC** button (5) to exit the menu.

Note:

- The scanning time that you set is also applied by the system to scanning carried out in CD/MP3, MMC, DAB and CD-changer mode.

Programme type (PTY)

Besides transmitting the station name, some FM stations also provide information on the type of programme that they are broadcasting. Your car radio can receive and display this information.

For example, the programme types can be:

CULTURE	TRAVEL	JAZZ
SPORT	NEWS	POP
ROCK	CLASSICS	

RADIO MODE

You can use the PTY function to select stations of a particular programme type.

PTY-EON

If you specify the programme type and start seek tuning, the radio will switch from the current station to a station of the selected programme type.

Notes:

- If the tuner does not find a station that corresponds to the selected programme type, you will hear a beep and “NO PTY” appears briefly on the display. The radio will then retune to the station that it received last.
- If the tuned radio station or another station on the broadcasting network broadcasts your selected programme type at a later point in time, the radio will automatically switch from the currently tuned station or from CD/MP3 mode or CD-changer mode to the station whose programme type matches the one you selected.

Switching PTY on/off

Note:

- The PTY functions can only be activated if the “DAB-FM” function is deactivated (DAB-FM OFF). For further information, please read the section entitled “Switching between DAB and FM” in the “DAB mode” chapter.

- ⇨ Press the **MENU•OK** button (7). “TUNER MENU” appears on the display.
- ⇨ Press the **MENU•OK** button (7) to display the tuner menu.
- ⇨ Press the **V** or **^** button (6) repeatedly until “PTY” appears on the display with the current setting.
- ⇨ Press the **>** or **<** button (6) to switch PTY ON or OFF.
- ⇨ Press the **MENU•OK** button (7) and then the **DIS•ESC** button (5) to exit the menu.

Selecting a programme type and starting seek tuning

- ⇨ Press the **<** or **>** button (6).

The programme type that you selected last appears on the display.

- ⇨ If you want to select another programme type, you can do so by pressing the **<** or **>** button (6) whilst this display is visible.

Or

- ⇨ Press one of the buttons **1 - 5** (10) to select a programme type that is assigned to one of these buttons.

The selected programme type appears briefly on the display.

- ⇨ Press the **V** or **^** button (6) to start seek tuning.

The radio will then tune into the next station that it finds that corresponds to your selected programme type.

Assigning a programme type to a station button

- ⇨ Select a programme type using the < or > button (6).
- ⇨ Press and hold the desired station button 1 - 5 (10) for longer than two seconds.

The programme type is stored on the selected button 1 - 5 (10).

Optimising radio reception

Treble reduction feature during interference (HICUT)

The HICUT function improves reception during poor radio reception (only FM). If reception interferences are present, the interference level is automatically reduced.

Switching HICUT on/off

- ⇨ Press the **MENU•OK** button (7).
“TUNER MENU” appears on the display.
- ⇨ Press the **MENU•OK** button (7) to display the tuner menu.
- ⇨ Press the **V** or **^** button (6) repeatedly until “HICUT” appears on the display.
- ⇨ Press the < or > button (6) to adjust the HICUT setting.

“HICUT 0” means that no automatic reduction of the interference level will be made; “HICUT 2” means that a maximum reduction will be made.

- ⇨ Press the **MENU•OK** button (7) and then the **DIS•ESC** button (5) to exit the menu.

SHARX

The SHARX function allows you to largely avoid interference caused by neighbouring radio stations (FM only). Switch on the SHARX function if the density of radio stations in your area is very high.

Switching SHARX on/off

- ⇨ Press the **MENU•OK** button (7).
“TUNER MENU” appears on the display.
 - ⇨ Press the **MENU•OK** button (7) to display the tuner menu.
 - ⇨ Press the **V** or **^** button (6) repeatedly until “SHARX” appears on the display.
 - ⇨ Press the < or > button (6) to switch SHARX on/off.
- “SHARX OFF” means automatic bandwidth switching is deactivated, “SHARX ON” means it is activated.
- ⇨ Press the **MENU•OK** button (7) and then the **DIS•ESC** button (5) to exit the menu.

RADIO MODE

Configuring the display

In radio mode, you can choose between various display modes.

1. "NORMAL MODE"

First line: Memory bank and station name (if it can be received)
Second line: frequency of the selected station.

2. "CLOCK Mode"

First line: Memory bank and station name (if it can be received)
Second line: frequency of the selected station and clock time.

3. "MINIMAL Mode"

First line: Memory bank and station name (if it can be received)
Second line: No display.

⇨ Briefly press the **DIS•ESC** button (5) to switch between the options.

Activating/deactivating the radio text display

Some stations use the RDS signal to broadcast scrolling texts known as radio texts. You can allow radio texts to be displayed or you can block them.

Since displaying radio texts can distract you from the current road and traffic situation, we ask you kindly to deactivate the "radio text" function or to use it only whilst the vehicle is stationary.

⇨ Press the **MENU•OK** button (7).

"TUNER MENU" appears on the display.

⇨ Press the **MENU•OK** button (7) to display the tuner menu.

⇨ Press the **V** or **^** button (6) repeatedly until "R-TEXT" appears on the display.

⇨ Press the **<** or **>** button (6) to switch RADIOTEXT on/off.

"R-TEXT OFF" means that no radio texts will be displayed and "R-TEXT ON" means they will be displayed.

⇨ Press the **MENU•OK** button (7) and then the **DIS•ESC** button (5) to exit the menu.

Traffic information

Your device is equipped with an RDS-EON receiver. EON stands for **E**nanced **O**ther **N**etwork.

Whenever a traffic announcement (TA) is broadcast, the system switches automatically from a station that does not provide traffic reports to the appropriate traffic information station within the broadcasting network that does.

Once the traffic report has been played, the system will switch back to the programme that you were listening to before.

DAB-FM traffic information source

If traffic information priority is activated, the device automatically switches to an incoming traffic announcement being broadcast via DAB within a DAB broadcasting network (in DAB mode) or via FM (in radio mode, see RDS-EON). In AUX, SD/MMC, CD/MP3 and CD-changer mode, you will hear traffic announcements played from the source that was active last (either DAB or radio).

Switching traffic information priority on/off

⇨ Press the **TRAF** button (8).

The priority for traffic announcements is activated if the display shows the traffic jam symbol.

Notes:

You will hear a warning beep:

- If you leave the reception area of a traffic information station that you are currently listening to.
- If, while listening to a CD/MP3, SD/MMC or a CD in the changer, you leave the reception area of a traffic information station that the system is tuned into and the subsequent automatic search cannot find a new traffic information station.
- If you retune the radio from a traffic information station to a station that does not broadcast traffic information.

If you hear the warning beep, you can either switch off traffic information priority or tune into a station that broadcasts traffic information.

Setting the volume for traffic announcements

- ⇨ Press the **MENU•OK** button (7).
- ⇨ Press the **V** or **Λ** button (6) repeatedly until "VOLUME MENU" appears on the display.
- ⇨ Press the **MENU•OK** button (7) to display the volume menu.
- ⇨ Press the **V** or **Λ** button (6) repeatedly until "TRAFFIC" appears on the display.
- ⇨ Adjust the volume using the **<>** buttons (6).
- ⇨ Press the **MENU•OK** button (7) and then the **DIS•ESC** button (5) to exit the menu.

Notes:

- Using the volume control (3), you can also adjust the volume during a traffic announcement for the duration of that announcement.
- You can adjust the sound settings and volume distribution settings for traffic announcements. For further information, please read the "Sound" chapter.

CD mode

You can use this device to play standard audio CDs, CD-Rs and CD-RWs with a diameter of 12 cm. To avoid problems when playing CDs, you should not burn CDs at speeds greater than 16-speed.

To ensure proper functioning, use only CDs with the Compact-Disc logo. Copy-protected CDs can cause playback problems. Blaupunkt cannot guarantee the proper functioning of copy-protected CDs!

Besides being able to play audio CDs on this device, you can also play CDs containing MP3 music files. For further information, please read the chapter entitled "MP3 mode".

 Risk of severe damage to the CD drive!

CD singles with a diameter of 8 cm and non-circular contoured CDs (shape CDs) must not be used.

We accept no responsibility for any damage to the CD drive that may occur as a result of the use of unsuitable CDs.

Switching to CD mode

If there is no CD inserted in the drive,

- ⇨ switch on the device by pressing button (1).
- ⇨ Press the  button (2).

The control panel opens.

- ⇨ Gently insert the CD with its printed side uppermost into the drive until you feel some resistance.

The drive draws in the CD automatically.

You must not hinder or assist the drive as it draws in the CD.

- ⇨ Gently close the control panel whilst exerting a little pressure until you feel it click into place.

The CD starts playing.

If a CD is already inserted in the drive,

- ⇨ press the **SRC** button (12) repeatedly until "CD" appears on the display.

Playback begins from the point at which it was last interrupted.

Selecting tracks

- ⇨ Press one of the arrow buttons (6) to select the next or previous track.

If you press the **V** or **<** button (6) once, the player will play the current track again from the beginning.

Fast track selection

To quickly select tracks backwards or forwards,

- ⇨ press and hold down one of the **Λ / V** buttons (6) until fast-reverse/fast-forward track selection begins.

Fast searching (audible)

To fast search backwards or forwards,

- ⇨ press and hold down one of the **<>** buttons (6) until fast searching backwards / forwards begins.

Random track play (MIX)

- ⇨ Press the **1 MIX** button (10).

"MIX CD ON" appears briefly on the display and the MIX symbol is displayed. The next randomly selected track will then be played.

Cancelling MIX

- ⇨ Press the **1 MIX** button (10) again.

"MIX CD OFF" appears briefly on the display and the MIX symbol disappears.

Scanning tracks (SCAN)

You can scan (briefly play) all the tracks on the CD.

- ⇨ Press and hold down the **MENU•OK** button (7) for longer than two seconds. The next track will then be scanned.

Note:

- You can set the scanning time. For further information, please read the section entitled "Setting the scanning time" in the "Radio mode" chapter.

Cancelling SCAN and continuing listening to a track

To end the scanning process,

- ⇨ press **MENU•OK** button (7).

CD MODE

The currently scanned track will then continue to be played normally.

Repeating tracks (REPEAT)

If you want to repeat a track,

⇒ press the **RPT 4** button (10).

“RPT TRK ON” appears briefly on the display and the RPT symbol is displayed. The track is repeated continuously until you deactivate RPT.

Cancelling REPEAT

If you want to cancel the repeat function,

⇒ press the **RPT 4** button (10) again.

“RPT TRK OFF” appears briefly on the display and the RPT symbol disappears. Normal playback is then resumed.

Changing the display

You can choose from various display options in CD mode:

- “NORMAL MODE”:
First line: Track number
Second line: Playing time
- “INFO MODE”:
First line: Track number and playing time.
Second line: CD text or CD name
- “CLOCK MODE”:
First line: Track number and playing time.
Second line: CD text or CD name and clock time
- “MINIMAL MODE”:
The title number is displayed on the top line.

Notes:

- In the menu you can configure whether you want to display the CD text or the CD name. For further information, please read the following section entitled “Displaying CD text”.
- CD text can only be displayed if the appropriate information is contained on the CD. The CD name can only be displayed if you have already named the CD. For further information, please read the section entitled “Naming CDs”.

To switch between the display options,

⇒ press the **DIS•ESC** button (5) once or several times until the display that you want appears.

Displaying CD text/CD name

Some CDs include CD text. The CD text might contain the names of the artist, album and tracks.

The CD text is displayed in the second line of the display instead of the CD name. You can allow the CD text to be displayed as scrolling text every time you switch to another track. The default display will appear again after the whole CD text has been shown once. For further information, please read the section entitled “Changing the display”.

Switching CD text on/off

- ⇨ Press the **MENU•OK** button (7).
- ⇨ Press the **V** or **Λ** button (6) repeatedly until “VARIOUS MENU” appears on the display.
- ⇨ Press the **MENU•OK** button (7).
- ⇨ Press the **V** or **Λ** button (6) repeatedly until “CD TEXT” or “CD NAME” appears on the display.
- ⇨ Use the **<>** buttons (6) to switch between the “CD TEXT” and “CD NAME” options.

When you have finished making your changes,

- ⇨ press the **MENU•OK** button (7) and then the **DIS•ESC** button (5) to exit the menu.

Scrolling CD text

If the CD that is inserted in the drive contains CD text, you can make the system display the text as scrolling text during playback.

- ⇨ Briefly press the **5 ►** button (10).

Naming CDs

The car sound system allows you to assign names for up to 30 CDs so that you can recognise them more easily. The names can be up to eight characters long.

“CD NAME FULL” will appear on the display if you try assigning more than 30 names.

Entering/editing CD names

- ⇨ Listen to the CD that you want.
- ⇨ Press the **MENU•OK** button (7).
- ⇨ Press the **V** or **Λ** button (6) repeatedly until “VARIOUS MENU” appears on the display.
- ⇨ Press the **MENU•OK** button (7).
- ⇨ Press the **V** or **Λ** button (6) repeatedly until “CD NAME EDIT” appears on the display.
- ⇨ Press the **MENU•OK** button (7).

You will now enter editing mode. If your CD does not have a name yet, “ABC-DEFGH” appears on the display. The first text input position flashes.

- ⇨ Use the **V / Λ** buttons (6) to select the character that you want. If you want an empty space, simply select the underscore.
- ⇨ Use the **< >** button (6) to move from one text input position to another.

CD MODE

When you have finished making your changes,

- ⇨ press the **MENU•OK** button (7) and then the **DIS•ESC** button (5) to exit the menu.

Deleting a CD name

- ⇨ Listen to the CD whose name you want to delete.
- ⇨ Press the **MENU•OK** button (7).
- ⇨ Press the **V** or **Λ** button (6) repeatedly until “VARIOUS MENU” appears on the display.
- ⇨ Press the **MENU•OK** button (7).
- ⇨ Press the **V** or **Λ** button (6) repeatedly until “CD NAME EDIT” appears on the display.
- ⇨ Press the **MENU•OK** button (7).
- ⇨ Press and hold down the **MENU•OK** button (7). After approx. four seconds you will hear a beep and “DELETE NAME” appears on the display.
- ⇨ Release the **MENU•OK** button (7).

The CD name will be deleted.

- ⇨ You can return to the menu by pressing the **MENU•OK** button (7).

Deleting all CD names

You can delete all the CD names stored in the car sound system.

- ⇨ Listen to a CD.
 - ⇨ Press the **MENU•OK** button (7).
 - ⇨ Press the **V** or **Λ** button (6) repeatedly until “VARIOUS MENU” appears on the display.
 - ⇨ Press the **MENU•OK** button (7).
 - ⇨ Press the **V** or **Λ** button (6) repeatedly until “CD NAME EDIT” appears on the display.
 - ⇨ Press the **MENU•OK** button (7).
 - ⇨ Press and hold down the **MENU•OK** button (7). After four seconds you will hear a beep and “DELETE NAME” appears on the display. Continue holding the button pressed down until you hear a second beep and “DELETE ALL” appears on the display.
 - ⇨ Release the **MENU•OK** button (7).
- The CD names will be deleted.

Traffic announcements in CD mode

If you wish to receive traffic announcements in CD mode,

- ⇨ press the **TRAF** button (8).

The priority for traffic announcements is activated if the display shows the traffic jam symbol. For further details, please read the chapter entitled "Traffic information".

Ejecting a CD

- ⇨ Press the  button (2).

The control panel opens out towards you.

- ⇨ Press the eject button (13) next to the CD compartment.

The CD is ejected.

- ⇨ Remove the CD and close the control panel.

Note:

- If a CD is ejected, the drive will automatically draw it back in again after approx. 10 seconds.
- You can also eject CDs whilst the device is switched off or whilst another audio source is activated.

MP3 mode

You can also use this car sound system to play CD-Rs and CD-RWs that contain MP3 music files.

Preparing an MP3 CD

The various combinations of CD burners, CD burning software and CD blanks may lead to problems arising with the device's ability to play certain CDs. If problems occur with your own burned CDs, you should try another brand of CD blank or choose another colour of CD blank. To avoid problems when playing CDs, you should not burn CDs at speeds greater than 16-speed.

The format of the CD must be ISO 9660 Level 1 / Level 2 or Joliet. Other formats cannot be played reliably.

You can create a maximum of 254 directories on a CD. You can use this device to access each of these directories.

Each directory can contain up to 255 files.

MP3 MODE

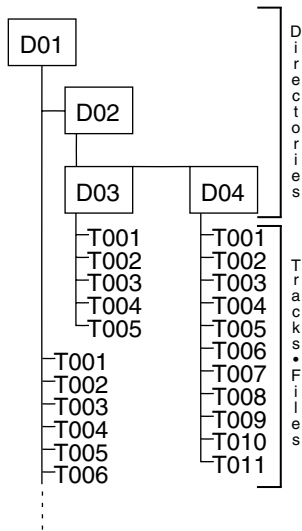

You can name each directory using a PC. The device is capable of displaying the directory name. Name the directories and tracks/files using your CD burner software. The software's instruction manual will provide details on how to do this.

Note:

- When naming directories and tracks/files you should avoid using accents and special characters. You can use a maximum of 32 characters (including the ".MP3" file extension) for track names and directory names.

If you like your files to be in the correct order, you should use burner software that places files in alphanumerical order. If your software does not provide this feature you also have the option of sorting the files manually. For this purpose, you must enter a number in front of each file name, e.g. "001", "002", etc. The leading zeros must also be entered.

MP3 tracks can contain additional information such as the artist, album and track names (ID3 tags). This device can display ID3 tags (version 1).

When creating (encoding) MP3 files from audio files, you should use bit rates up to a maximum of 256 kbits/sec.

This device can only play MP3 files that have the ".MP3" file extension.

Notes:

To ensure uninterrupted playback,

- do not try changing the file extension to ".MP3" of any files other than MP3 files and then attempt to play them! The device will ignore these invalid files during playback.
- Do not use "mixed" CDs containing both non-MP3 data and MP3 tracks (the device only reads MP3 files during MP3 playback).
- Do not use mix-mode CDs containing both CD-audio tracks and MP3 tracks. If you try playing a mix-mode CD, the device will only play the CD-audio tracks.

Switching to MP3 mode

MP3 mode is activated in the same way as normal CD mode. For further information, please read the section entitled "Switching to CD mode" in the "CD mode" chapter.

Configuring the display

Configuring the default display

You can display various types of information on the current track:

1. "NORMAL MODE":
First line: Track name
Second line: Directory name
2. "INFO MODE":
First line: Track name.
Second line: MP3-ID-TAG (if available and activated, see "Selecting MP3 info")

Note:

- The system can display MP3-ID tags (version 1) if they have been saved with the MP3 files (for further information, please read the instructions that came with your PC's MP3 software or burner software).
3. "MP3 BROWSE MODE":
First line: Track name
Second line: Directory name.

Note:

- You can use MP3 browse mode to find MP3 files on your CD quickly and conveniently. The functions Fast searching, MIX, SCAN and REPEAT as well as the menu cannot be used in MP3 browse mode.

4. "TRACK AND DIR MODE":
First line: Directory number and track number.
Second line: Playing time.
5. "CLOCK MODE":
First line: Directory number and track number.
Second line: Directory name and clock time

To switch between the different display options,

- ⇨ press the **DIS•ESC** button (5).

Selecting a directory

Selecting a directory using the arrow buttons (Normal, info, track and dir and clock mode)

To move up or down to another directory,

- ⇨ press the **V** or **Λ** button (6) once or several times.

Note:

- The device will automatically skip any directories that do not contain MP3 files. The device will automatically correct the number of directories for the display. This number might therefore no longer be identical to the number of directories that you actually created.

MP3 MODE

Selecting the directory in browse mode

You can display the current and subsequent directory in both lines of the display. The directories are displayed with the names that you created when burning the CD. Whilst the directories are being displayed, you can use the arrow buttons to display and select all the available directories.

- ⇒ During MP3 playback, press the **DIS•ESC** button (5) repeatedly until “MP3 BROWSE MODE” appears on the display.
- ⇒ Press the **V** or **^** button (6) to display the directories on the CD.
- ⇒ If you want to select a directory, press one of the **V** / **^** buttons (6) repeatedly until the directory is shown in the top line of the display and then press the **MENU•OK** (7).

The selected directory opens and the first track starts playing. The tracks contained in the directory are displayed in browse mode.

Selecting tracks

Selecting tracks/files using the arrow buttons (Normal, info, track and dir and clock mode)

To move up or down to another track/file in the current directory,

- ⇒ press the **<** or **>** button (6) once or several times.

If you press the **<** button (6) once, the current track will be played again from the beginning.

Selecting tracks in browse mode

Browse mode conveniently allows you to view the tracks contained in a directory and then select a particular track.

- ⇒ During MP3 playback, repeatedly press the **DIS•ESC** button (5) until “MP3 BROWSE MODE” is displayed.
- ⇒ Press the **<** or **>** button (6) to display all the tracks contained in the directory one after another.

If you want to select the currently displayed title,

- ⇒ press the **MENU•OK** button (7).

Fast searching (not in MP3 browse mode)

To fast search backwards or forwards,

- ⇒ press and hold down the **<** or **>** button (6) until fast searching backwards / forwards begins.

Random track play – MIX **(not in MP3 browse mode)**

To play the tracks in the current directory in random order,

⇨ briefly press the **1 MIX** button (10).

“MIX DIR” appears on the display and the MIX symbol is displayed.

To play the tracks contained in all the directories on the inserted MP3 CD in random order,

⇨ press the **1 MIX** button (10).

“MIX CD” appears on the display and the MIX symbol is displayed.

Cancelling MIX

To cancel MIX,

⇨ briefly and repeatedly press the **1 MIX** (10) button until “MIX OFF” appears on the display.

The MIX symbol disappears.

Scanning tracks – SCAN **(not in MP3 browse mode)**

You can scan (briefly play) all the tracks on the CD.

⇨ Press and hold down the **MENU•OK** button (7) for longer than two seconds. The next track will then be scanned.

“SCAN” and the selected display mode appear alternately on the display (see “Configuring the display”).

Note:

- You can set the scanning time. For further information on setting the scanning time, please read the section entitled “Setting the scanning time” in the “Radio mode” chapter.

Cancelling SCAN and continuing listening to a track

⇨ Press the **MENU•OK** button (7).

The currently scanned track will then continue to be played normally.

Repeating individual tracks or whole directories – REPEAT **(not in MP3 browse mode)**

To play the current track repeatedly,

⇨ briefly press the **4 RPT** button (10).

“REPEAT TRACK” and RPT appear briefly on the display.

To repeat the whole directory,

⇨ press the **4 RPT** button (10) again.

“REPEAT DIR” appears briefly on the display.

Cancelling REPEAT

To stop the current track or current directory from being repeated,

⇨ briefly and repeatedly press the **4 RPT** button (10) until “REPEAT OFF” appears on the display.

RPT disappears from the display.

MP3 MODE

Selecting MP3 info

If you want to select the “MP3 INFO” display mode, you first have to activate this function in the menu. In order for the system to be able to display MP3 information, the information must be stored on the CD in the form of ID tags together with the MP3 files.

- ⇒ Press the **MENU•OK** button (7).
- ⇒ Press the **V** or **▲** button (6) repeatedly until “VARIOUS MENU” appears on the display.
- ⇒ Press the **MENU•OK** button (7).
- ⇒ Press the **V** or **▲** button (6) repeatedly until “MP3 INFO” appears on the display.
- ⇒ Use the **<>** buttons (6) to switch between the “ON” and “OFF” options.

When you have finished making your changes,

- ⇒ press the **MENU•OK** button (7) and then the **DIS•ESC** button (5) to exit the menu.

Displaying scrolling text

The selected information title, track names or file name and directory name are shown once as scrolling text when the title changes. To display the information again as scrolling text,

- ⇒ briefly press button **5 ►** (10).

Programming your favourite tracks on an MP3 CD

Using the TPM function (**T**rack **P**rogram **M**emory), you can program and play up to 192 favourite tracks for a maximum of 3 CDs or MMCs. You can program the tracks in any order you like, however, the tracks will always be played in ascending order. If you have activated the favourite track (TPM) feature, only the previously programmed tracks on the current MP3 CD/SD/MMC will be played.

Programming favourite tracks

To program your favourite tracks for a CD, proceed as follows:

- ⇒ Select your first favourite track.
- ⇒ Press and hold down the **TPM 2** button (10) for longer than two seconds.

“TRACK STORED” appears on the display. The track has now been added to the list of favourite tracks for this CD.

- ⇒ Continue in the same way for all your remaining favourite tracks on the CD.

Switching TPM on/off

To switch the TPM function on/off,

- ⇒ press the **TPM 2** button (10) repeatedly until “TPM ON” or “TPM OFF” appears on the display.

If no tracks are programmed, an appropriate notification will be displayed.

Deleting individual tracks from a list

You can delete individual tracks from a list of favourite tracks.

- ⇨ Listen to the track that you want to delete from the list.
- ⇨ Press and hold down the **3 CLR** button (10) for longer than **two** and less than four seconds until you hear a confirmation beep.

The display shows "TRACK CLEARED" and the title is deleted.

Delete list of inserted CD

You can delete all stored tracks of the current CD.

- ⇨ Press and hold down the **3 CLR** button (10) for longer than **four** and less than **eight** seconds until you hear a double confirmation beep.

The display shows "CD CLEARED" and the list of the CD is deleted.

Deleting all the lists for all CDs

You can delete all the stored tracks for all the CDs.

- ⇨ Press and hold down the **3 CLR** button (10) for longer than **eight** seconds until you have heard all three confirmation beeps.

The display shows "DELETING", followed by "ALL CLEARED", and all lists of all CDs are deleted.

SD/MMC mode

You can play files stored on an SD/MMC (**M**ulti-**M**edia **C**ard / **S**ecure **D**igital) using the Nashville DAB35. You can write data onto the SD/MMC that you want to use with the Nashville DAB35 with the help of a standard SD/MMC card reader and your PC.

Note:

- Please note that when you prepare the SD/MMC, you must observe the directory structure rules as described in the "MP3 mode" chapter.

In order to optimise the device's access to the data on the SD/MMC, you should store no more than 20 directories and a maximum of 200 files on an SD/MMC.

Inserting/removing SDs/MMCs

The SD/MMC slot is located on the left below the CD compartment. To insert/remove an MMC, you must first detach the control panel. To do so, please read the "Detachable control panel" chapter.

Inserting the SD/MMC

- ⇨ Detach the control panel.
- ⇨ Insert the SD/MMC with its labelled side uppermost and its contacts first into the SD/MMC slot until you feel the SD/MMC click into place.
- ⇨ Attach the control panel again.

SD/MMC MODE

Removing an SD/MMC

- ⇨ Detach the control panel.
- ⇨ Carefully push the SD/MMC into the device until you feel a slight resistance.

The SD/MMC is now unlatched.

- ⇨ Carefully pull the SD/MMC out of the slot.
- ⇨ Attach the control panel again.

Switching to SD/MMC mode

- ⇨ Press the **SRC** button (12) repeatedly until “MMC” appears on the display.

Playback begins with the first track that the device detects.

Configuring the display

Configuring the default display

You can display various types of information on the current track:

1. “NORMAL MODE”:
First line: Track name
Second line: Directory name
2. “INFO MODE”:
First line: Track name.
Second line: MP3-ID-TAG (if available and activated, see “Selecting MP3 info”) or directory name.

Note:

- The system can display MP3-ID tags (version 1) if they have been saved with the MP3 files (for further information, please read the instructions that came with your PC’s MP3 software or burner software).

3. “MP3 BROWSE MODE”:
First line: Directory name
Second line: Track name.

Note:

- You can use MP3 browse mode to find MP3 files on your CD quickly and conveniently. The functions Fast searching, MIX, SCAN and REPEAT as well as the menu cannot be used in MP3 browse mode.
4. “TRACK AND DIR MODE”:
First line: Directory number and directory number.
Second line: Playing time.
 5. “CLOCK MODE”:
First line: Directory number and track number.
Second line: Directory name and clock time

To switch between the different display options,

- ⇨ press the **DIS•ESC** button (5).

Selecting a directory

Selecting a directory using the arrow buttons (Normal, info, track and dir and clock mode)

To move up or down to another directory,

- ⇨ press the **V** or **^** button (6) once or several times.

Note:

- The device will automatically skip any directories that do not contain MP3 files. The device will automatically correct the number of directories for the display. This number

might therefore no longer be identical to the number of directories that you actually created.

Selecting the directory in browse mode

You can display the current and subsequent directory in both lines of the display. The directories are displayed with the names that you used when you created the directories on the SD/MMC. Whilst the directories are being displayed, you can use the arrow buttons to display and select all the available directories.

- ⇨ During MP3 playback, press the **DIS•ESC** button (5) repeatedly until “MP3 BROWSE MODE” appears on the display.
- ⇨ Press the **V** or **^** button (6) to display the directories on the CD.
- ⇨ If you want to select a directory, press one of the **V / ^** buttons (6) repeatedly until the directory is shown in the **top** line of the display and then press the **MENU•OK** button (7).

The selected directory opens and the first track starts playing. The tracks contained in the directory are displayed in browse mode.

Selecting tracks

Selecting tracks/files using the arrow buttons (Normal, info, track and dir and clock mode)

To move up or down to another track/file in the current directory,

- ⇨ press the **<** or **>** button (6) once or several times.

If you press the **<** button (6) once, the current track will be played again from the beginning.

Selecting tracks in browse mode

Browse mode conveniently allows you to view the tracks contained in a directory and then select a particular track.

- ⇨ During MP3 playback, repeatedly press the **DIS•ESC** button (5) until “MP3 BROWSE MODE” is displayed.
- ⇨ Press the **<** or **>** button (6) to display all the tracks contained in the directory one after another.

If you want to select the currently displayed title,

- ⇨ press **MENU•OK** button (7).

SD/MMC MODE

Fast searching (not in MP3 browse mode)

To fast search backwards or forwards,

- ⇨ press and hold down the < or > button (6) until fast searching backwards / forwards begins.

Random track play – MIX (not in MP3 browse mode)

To play the tracks in the current directory in random order,

- ⇨ briefly press the **1 MIX** button (10).

“MIX DIR” appears on the display and the MIX symbol is displayed.

To play the tracks contained in all the directories on the inserted SD/MMC in random order,

- ⇨ press the **1 MIX** button (10).

“MIX MMC” appears on the display and the MIX symbol is displayed.

Cancelling MIX

To cancel MIX,

- ⇨ briefly and repeatedly press the **1 MIX** (10) button until “MIX OFF” appears on the display.

The MIX symbol disappears.

Scanning tracks – SCAN (not in MP3 browse mode)

You can scan (briefly play) all the tracks on the CD.

- ⇨ Press and hold down the **MENU•OK** button (7) for longer than two seconds. The next track will then be scanned.

“SCAN” and the selected display mode appear alternately on the display (see “Configuring the display”).

Note:

- You can set the scanning time. For further information on setting the scanning time, please read the section entitled “Setting the scanning time” in the “Radio mode” chapter.

Cancelling SCAN and continuing listening to a track

- ⇨ Press the **MENU•OK** button (7).

The currently scanned track will then continue to be played normally.

Repeating individual tracks or whole directories – REPEAT (not in MP3 browse mode)

To play the current track repeatedly,

- ⇨ briefly press the **RPT 4** button (10).

“REPEAT TRACK” and RPT appear briefly on the display.

To repeat the whole directory,

- ⇨ press the **RPT 4** button (10) again.

“REPEAT DIR” appears briefly on the display.

Cancelling REPEAT

To stop the current track or current directory from being repeated,

- ⇨ briefly and repeatedly press the **RPT 4** button (10) until “REPEAT OFF” appears on the display.

RPT disappears from the display.

Selecting MP3 info

If you want to select the “MP3 INFO” display mode, you first have to activate this function in the menu. In order for the system to be able to display MP3 information, the information must be stored on the CD in the form of ID tags together with the MP3 files.

- ⇨ Press the **MENU•OK** button (7).
- ⇨ Press the **V** or **^** button (6) repeatedly until “VARIOUS MENU” appears on the display.
- ⇨ Press the **MENU•OK** button (7).
- ⇨ Press the **V** or **^** button (6) repeatedly until “MP3 INFO” appears on the display.
- ⇨ Use the **<>** buttons (6) to switch between the “ON” and “OFF” options.

When you have finished making your changes,

- ⇨ press the **MENU•OK** button (7) and then the **DIS•ESC** button (5) to exit the menu.

Displaying scrolling texts

The selected information title, track names or file name and directory name are shown once as scrolling text when the title changes. To display the information again as scrolling text,

- ⇨ briefly press button **5** ► (10).

Recording DAB programmes onto SDs/MMCs

You can use this device to record a DAB programme on an inserted SD/MMC card. The DAB data stream is then stored as an MPEG file on the SD/MMC (MPEG 1, Layer 2).

A variety of SD/MMC are commercially available.

Since the quality and the software of the SD/MMC can deviate, Blaupunkt cannot guarantee the proper functioning of all SD/MMC that are commercially available.

For this reason, Blaupunkt recommends the use of SD/MMC cards from “SanDisk” and “Panasonic” with a maximum capacity of 512 MB since these cards showed the best functionality.

Formatting with the PC cannot ensure that files can be stored and read without any problems.

The only supported file system is FAT16. If you attempt to record onto an SD/MMC that is formatted differently, you will see “UNFORMATTED” appear on the display.

SD/MMC MODE

Before using SD/MMCs in the Nashville DAB35, they must be formatted in the DAB35. For further details on this, please read the section entitled "Formatting SD/MMC" in the "SD/MMC mode" chapter.

Before starting to record, you should make sure that there is sufficient space on the inserted SD/MMC and that the SD/MMC does not have more than 251 directories stored on it.

During the recording, an SD/MMC must not be removed from the device. Always switch off the Nashville DAB35 first before removing an SD/MMC card.

Starting recording

To record a DAB programme onto an SD/MMC,

- ⇒ switch to DAB mode and select the programme that you want to record. For further details on this, please read the "DAB mode" chapter.
- ⇒ Press the **REC•DEL** button  when you want to start recording.

Notes:

- You cannot start recording during the first 15 seconds after switching to DAB mode or after switching on the radio with DAB mode activated. This also applies if you pressed the **REC•DEL** button  and the display shows "RECORDING".
- To avoid damaging the SD/MMC, you should never start the engine whilst recording. Starting the engine might cause the voltage of

the vehicle's electrical system to drop, which could permanently damage the SD/MMC.

- The automatic DAB-FM switching feature is deactivated whilst recording is taking place. The DAB programme remains tuned during recording, even if the reception quality deteriorates.

Recording starts and "RECORDING" appears on the display for approx. 2 seconds.

If there is insufficient space available on the card, "CARD FULL" appears on the display for approx. 2 seconds. In this case, delete items from the SD/MMC (see "Deleting recordings" following below) or insert a different SD/MMC.

The file created during recording is given a name as follows:

ddhhmmss.mp3. "dd" stands for the day the recording was made, "hh" stands for the hour recording was started, "mm" stands for minutes and "ss" for seconds.

The device creates the "DAB_DIR" directory on the SD/MMC to store the recorded files.

Telephone/navigation during recording

Telephone calls or voice output from a navigation system do not affect recording. The DAB programme continues to be recorded in the background during a telephone call or voice output.

Stopping recording

If you want to stop recording,

- ⇨ briefly press the **REC•DEL** button .

“RECORDING STOPPED” appears on the display for approx. two seconds.

Recording is stopped automatically in the following cases:

- If the storage space on the SD/MMC fills completely during recording. In this case, “CARD FULL” appears on the display.
- If you switch programmes during the recording.
- If a problem arises with communications between the SD/MMC and the device, you will see “MMC ERROR” appear on the display and recording is then stopped.
- If you deactivate DAB mode whilst recording, e.g. by switching to CD mode or radio mode.

Making a timer-controlled recording of a DAB programme

You can use this device to record a DAB programme at a preset time. While the car sound system is switched off, the DAB programme played last (if it can be received) is recorded for a specified time (adjustable from 1 to 90 minutes). You can programme two timers.

Switching timer-controlled recording on/off

- ⇨ In SD/MMC mode, press and hold down the **REC•DEL**  for longer than two seconds.

The MMC record menu is displayed. “MMC REC ON” or “MMC REC OFF” appears on the display.

- ⇨ Press the **<** or **>** button  to switch between the settings “MMC REC ON” and “MMC REC OFF”.

Setting the timer and recording duration

You can programme two recording timers.

Note:

- If you only want to make one recording at a particular time, set the second timer to the same time setting as the first.
- ⇨ In SD/MMC mode, press and hold down the **REC•DEL**  for longer than two seconds.

SD/MMC MODE

The MMC record menu is displayed. “MMC REC ON” or “MMC REC OFF” appears on the display.

⇒ Press the **▲** button (6).

The currently set recording “DURATION” is displayed. The set recording duration is the same for both timers.

To set the recording duration,

⇒ adjust the recording duration using the **</>** buttons (6).

⇒ Press the **▲** button (6).

TIMER 1 and the set clock time are displayed.

To adjust TIMER 1,

⇒ press the **MENU•OK** button (7).

The hours behind “TIMER 1” begin to flash.

⇒ Use the **▲/▼** buttons (6) to set the hour at which you want recording to begin.

To set the minutes for the start of recording,

⇒ press the **>** button (6).

The minutes behind “TIMER 1” begin to flash.

⇒ Use the **▲/▼** buttons (6) to set the minute at which you want recording to begin.

⇒ Press the **MENU•OK** button (7).

Note:

- If you want to set the second timer, press the **▲** button (6) whilst “TIMER 1” is being displayed. “TIMER 2” is displayed. Adjust the settings for “TIMER 2” in the same way as described for “TIMER 1”.

The settings are saved.

To close the MMC-RECORD menu,

⇒ press and hold down the **REC•DEL** (9) for longer than two seconds.

Playing recordings using the device

You can listen to the recording by selecting its corresponding file name in the “**DAB_DIR**” directory on the SD/MMC. For further details on this, please read the sections entitled “Selecting a directory” and “Selecting tracks” at the start of the chapter. If you switch to SD/MMC mode after making a recording, the device will start playing the track that was recorded first.

⇒ To select the track that was recorded last, press the **<** button (6) as soon as playback begins.

Playing recordings on other devices

You can also play the recordings on your PC. To do so, you need an SD/MMC card reader and a player software application. You can also listen to recordings on players that are capable of reading SDs/MMCs.

Notes:

- Even though the file is not an MP3 file, it is still given the “mp3” file extension. Since all standard player software applications support Layer 2 files, you can play them on a computer. If you experience problems when playing the files on another device, please check that the player is compatible with Layer 2.
- The Nashville DAB35 uses special algorithms for playing DAB programmes in order to ensure an optimum listening experience even if you are playing material that was recorded during poor reception. PC programmes do not use special signal processing, which means that files might sound different when listened to on a computer, e.g. errors are not suppressed and distortion might be heard.

Deleting recordings

You can delete individual files that are stored on an SD/MMC.

- ⇨ Listen to the file that you want to delete from the SD/MMC.
- ⇨ Press the **REC•DEL** button (9).

For two seconds, the display shows “DELETE ? YES = REC•DEL”.

- ⇨ Press the **REC•DEL** button (9) during these two seconds.
- ⇨ Repeat this procedure with all the tracks that you want to delete.

Formatting SDs/MMCs

You can format an SD/MMC in the device. All the data that are stored on it are deleted in the process.

Note:

- You should format the SD/MMC in the device to ensure card compatibility with the device.

You can only format the card whilst the device is set to AUX, CD/MP3 or FM mode.

- ⇨ Switch to FM radio mode. For further details on this, please read the “Radio mode” chapter.
- ⇨ Press the **MENU•OK** button (7).
- ⇨ Press the **V** button (6) repeatedly until “VARIOUS MENU” appears on the display.
- ⇨ Press the **MENU•OK** (7), to display the menu.
- ⇨ Press the **▲ / ▼** buttons (6) to select “MMC FORMAT”.
- ⇨ Press the **< or >** button (6).

“ARE YOU SURE? YES=OK
NO=ESC” appears on the display.

- ⇨ Press the **MENU•OK** (7), to format the card.

SD/MMC MODE

Configuring the display

You can choose between various display options. For further details on this, please read the section entitled “Configuring the display” in the “MP3 mode” chapter.

Programming your favourite tracks for an SD/MMC

Using the TPM function (Track Program Memory), you can program and play your favourite tracks for an SD/MMC. Programming is carried out in the same way as described in “Programming your favourite tracks for an MP3 CD” in the “MP3 mode” chapter.

Switching pre-record on/off

If you switch on the DAB pre-record function, between 20 and 60 seconds of the running programme are always buffered. This allows you to start the recording even shortly after the title started without missing the beginning of the title.

The size of the memory determines the length of the buffered file dependent upon the data rate of the received DAB programme. Therefore, 20 seconds can be buffered at a data rate of 192 Kbits/s, 30 seconds at 128 Kbits/s and 60 seconds at 64 Kbits/s. The usual bit rate for DAB is 192 Kbits/s.

If you have activated the pre-record function and then start a recording in DAB mode, approx. 20 seconds (in the case of 192 Kbits/s) that were broadcast before you pressed the record button will always be included in the recording (The first 15 seconds directly after switching to DAB mode, however, are excluded.).

- ⇨ Press the **MENU•OK** button (7).
- ⇨ Press the **V** button (6) repeatedly until “VARIOUS MENU” appears on the display.
- ⇨ Press the **MENU•OK** (7), to display the menu.
- ⇨ Press the **^ / v** buttons (6) to select “PRE REC ON” or “PRE REC OFF”.
- ⇨ Press the **< or >** button (6) to switch the pre-recording function ON or OFF.

When you have finished making your changes,

- ⇨ press the **MENU•OK** button (7) and then the **DIS•ESC** button (5) to exit the menu.

CD-changer mode

Note:

- Information on handling CDs, inserting CDs and operating the CD changer can be found in the operating instructions supplied with your CD changer.

Switching to CD-changer mode

- ⇨ Press the **SRC** button (12) repeatedly until "MMC" appears on the display.

The device starts playing the first CD that the CD changer detects.

Selecting CDs

To move up or down to another CD,

- ⇨ press the **V** or **^** button (6) once or several times.

Note:

- The device will ignore empty CD slots in the changer and slots containing invalid CDs.

Selecting tracks

To move up or down to another track on the current CD,

- ⇨ press the **>** or **<** button (6) once or several times.

Fast searching (audible)

To fast search backwards or forwards,

- ⇨ press and hold down one of the **<>** buttons (6) until fast searching backwards / forwards begins.

Changing the display

You can choose from various display options in CD mode:

- "NORMAL MODE":
First line: Track number
Second line: CD number / CD name and playing time
- "CLOCK MODE":
First line: Track number.
Second line: CD number / CD name and clock time
- "MINIMAL MODE":
First line: Track number.

To switch between the display options,

- ⇨ press the **DIS•ESC** button (5).

In the menu you can choose to display the CD name (if available) instead of the CD number. (For further information, please read the "Naming CDs" section):

- ⇨ Press the **MENU•OK** button (7).
- ⇨ Press the **V** or **^** button (6) repeatedly until "VARIOUS MENU" appears on the display.
- ⇨ Press the **MENU•OK** button (7).
- ⇨ Press the **V** or **^** button (6) repeatedly until "CD NAME" or "DISC NUMBER" appears on the display.
- ⇨ Use the **<>** buttons (6) to switch between the "CD NAME" and "DISC NUMBER" options.

CD CHANGER MODE

When you have finished making your changes,

- ⇨ press the **MENU•OK** button (7) and then the **DIS•ESC** button (5) to exit the menu.

Repeating individual tracks or whole CDs (REPEAT)

To repeat the current track,

- ⇨ briefly press the **RPT 4** button (10).

“RPT TRK” appears briefly and RPT lights up on the display.

To repeat the current CD,

- ⇨ press the **RPT 4** button (10) again.

“RPT CD” appears briefly and RPT lights up on the display.

Cancelling REPEAT

To stop the current track or current CD from being repeated,

- ⇨ repeatedly press button **RPT 4** (10) until “RPT OFF” appears on the display and RPT disappears.

Random track play (MIX)

To play the tracks on the current CD in random order,

- ⇨ briefly press the **1 MIX** button (10).

“MIX CD” appears briefly and MIX lights up on the display.

To play the tracks on all inserted CDs in random order,

- ⇨ press the **1 MIX** button (10) again.

“MIX ALL” appears briefly and MIX lights up on the display.

Cancelling MIX

- ⇨ Press the **1 MIX** button (10) repeatedly until “MIX OFF” appears on the display.

Scanning all tracks on all CDs (SCAN)

To scan (briefly play) all the tracks on all the inserted CDs in ascending order,

- ⇨ press and hold down the **MENU•OK** button (7) for longer than two seconds.

“SCAN” and the selected display mode appear alternately on the display.

Note:

- You can set the scanning time. For further information, please read the section entitled “Setting the scanning time” in the “Radio mode” chapter.

Stopping SCAN

To stop scanning,

- ⇨ press the **MENU•OK** button (7).

The currently scanned track will then continue to be played normally.

Naming CDs

The car sound system allows you to assign names for up to 30 CDs so that you can recognise them more easily. The names can be a maximum of seven characters long.

“CD NAME FULL” will appear on the display if you try assigning more than 30 names.

Entering/editing CD names

- ⇨ Listen to the CD that you want.
- ⇨ Press the **MENU•OK** button (7).
- ⇨ Press the **V** or **Λ** button (6) repeatedly until “VARIOUS MENU” appears on the display.
- ⇨ Press the **MENU•OK** button (7).
- ⇨ Press the **V** or **Λ** button (6) repeatedly until “CD NAME EDIT” appears on the display.
- ⇨ Press the **MENU•OK** button (7).

You will now enter editing mode. If your CD does not have a name yet, “ABC-DEFG” appears on the display.

The currently active text input position flashes.

- ⇨ Use the **V / Λ** buttons (6) to select the character that you want. If you want an empty space, simply select the underscore.
- ⇨ Use the **<** or **>** button (6) to move from one text input position to another.

When you have finished making your changes,

- ⇨ press the **MENU•OK** button (7) and then the **DIS•ESC** button (5) to exit the menu.

Deleting a CD name

- ⇨ Listen to the CD whose name you want to delete.
- ⇨ Press the **MENU•OK** button (7).
- ⇨ Press the **V** or **Λ** button (6) repeatedly until “VARIOUS MENU” appears on the display.
- ⇨ Press the **MENU•OK** button (7).
- ⇨ Press the **V** or **Λ** button (6) repeatedly until “CD NAME EDIT” appears on the display.
- ⇨ Press the **MENU•OK** button (7).

The name of the current CD is displayed.

- ⇨ Press and hold down the **MENU•OK** button (7). After approx. four seconds you will hear a beep and “DELETE NAME” appears on the display.

- ⇨ Release the **MENU•OK** button (7).

The CD name will be deleted.

- ⇨ You can return to the menu by pressing the **MENU•OK** button (7).

Deleting all CD names

You can delete all the CD names stored in the car sound system.

- ⇒ Listen to a CD.
- ⇒ Press the **MENU•OK** button (7).
- ⇒ Press the **V** or **Λ** button (6) repeatedly until "VARIOUS MENU" appears on the display.
- ⇒ Press the **MENU•OK** button (7).
- ⇒ Press the **V** or **Λ** button (6) repeatedly until "CD NAME EDIT" appears on the display.
- ⇒ Press the **MENU•OK** button (7).

The name of the current CD is displayed.

- ⇒ Press and hold down the **MENU•OK** button (7). After approx. four seconds you will hear a beep and "DELETE NAME" appears on the display. Continue holding the button pressed down until you hear a second beep and "DELETE ALL" appears on the display.

- ⇒ Release the **MENU•OK** button (7).

The CD names will be deleted.

- ⇒ You can close the menu by pressing the **MENU•OK** button (7).

CLOCK time**Displaying the time**

You can make the clock time appear continuously in the bottom part of the display while any audio source is activated. For further information, please read the "Configuring the display" sections in the relevant chapters.

Setting the clock automatically

You can configure the system to set the clock time automatically using the RDS signal.

- ⇒ Press the **MENU•OK** button (7).
- ⇒ Press the **V** or **Λ** button (6) repeatedly until "CLOCK MENU" appears on the display.
- ⇒ Press the **MENU•OK** button (7).
- ⇒ Press the **Λ** or **V** button (6) repeatedly until "CLOCK AUTO" or "CLOCK MANUAL" appears on the display.
- ⇒ Select the "CLOCK AUTO" setting using the **<** or **>** button (6).
- ⇒ Press the **MENU•OK** button (7).

The menu appears again.

Setting the clock manually

To set the clock time manually,

- ⇒ press the **MENU•OK** button (7).
- ⇒ Press the **V** or **Λ** button (6) repeatedly until "CLOCK MENU" appears on the display.
- ⇒ Press the **MENU•OK** button (7).

- ⇨ Press the **▲** or **▼** button (6) repeatedly until "CLOCK SET" appears on the display.
 - ⇨ Press the **MENU•OK** button (7).
- The time appears on the display. The hours flash and can be adjusted.

- ⇨ Set the hours using the **▲ / ▼** buttons (6).

Once the hours are set,

- ⇨ press the **>** button (6).

The minutes flash.

- ⇨ Set the minutes using the **▲ / ▼** buttons (6).
- ⇨ Press the **MENU•OK** button (7) and then the **DIS•ESC** button (5).

Selecting 12/24-hour clock mode

- ⇨ Press the **MENU•OK** button (7).
- ⇨ Press the **▼** or **▲** button (6) repeatedly until "CLOCK MENU" appears on the display.
- ⇨ Press the **MENU•OK** button (7).
- ⇨ Press the **▲** or **▼** button (6) repeatedly until "24 HOUR MODE" or "12 HOUR MODE" appears on the display.
- ⇨ Press the **<** or **>** button (6) to switch between the modes.

When you have finished making your changes,

- ⇨ press the **MENU•OK** button (7) and then the **DIS•ESC** button (5) to exit the menu.

Displaying the time continuously when the device is off and the ignition is on

To display the time when the device is off and the vehicle ignition is on,

- ⇨ press the **MENU•OK** button (7).
- ⇨ Press the **▼** or **▲** button (6) repeatedly until "CLOCK MENU" appears on the display.
- ⇨ Press the **MENU•OK** button (7).
- ⇨ Press the **▲** or **▼** button (6) repeatedly until "OFF CLOCK OFF" or "OFF CLOCK ON" appears on the display.
- ⇨ Press the **<** or **>** button (6) to switch between the ON/OFF settings.

When you have finished making your changes,

- ⇨ press the **MENU•OK** button (7) and then the **DIS•ESC** button (5) to exit the menu.

SOUND

Sound

You can adjust the sound settings (bass and treble) separately for each source (radio, CD/MP3, CD changer, AUX, traffic announcement, telephone/navigation). The volume distribution settings (balance and fader) apply to all the audio sources.

Note:

- You can only adjust the audio settings for traffic announcements and the navigation system whilst a traffic announcement or navigation announcement is actually playing. Likewise, you can only adjust the telephone audio settings during a telephone call.

Adjusting the bass

- ⇨ Press the **AUD•DEQ** button (11).
- ⇨ Press the **< or >** button (6) to adjust the bass.
- ⇨ Press the **AUD•DEQ** button (11) to close the menu or press the **▲** or **▼** button (6) to make further changes to the settings.

Adjusting the treble

- ⇨ Press the **AUD•DEQ** button (11).
- ⇨ Press the **▲** or **▼** button (6) repeatedly until "TREBLE" appears on the display.
- ⇨ Press the **< or >** button (6) to adjust the treble.
- ⇨ Press the **AUD•DEQ** button (11) to close the menu or press the **▲** or **▼** button (6) to make further changes to the settings.

Setting the left/right volume distribution (balance)

To adjust the left/right volume distribution (balance),

- ⇨ press the **AUD•DEQ** button (11).
- ⇨ Press the **▲** or **▼** button (6) repeatedly until "BALANCE" appears on the display.
- ⇨ Press the **< or >** button (6) to adjust the balance (right/left).
- ⇨ Press the **AUD•DEQ** button (11) to close the menu or press the **▲** or **▼** button (6) to make further changes to the settings.

Adjusting the front/rear volume distribution (fader)

To adjust the front/rear volume distribution (fader),

- ⇨ press the **AUD•DEQ** button (11).
- ⇨ Press the **▲** or **▼** button (6) repeatedly until "FADER" appears on the display.
- ⇨ Press the **< or >** button (6) to adjust the fader (front/rear).
- ⇨ Press the **AUD•DEQ** button (11) to close the menu or press the **▲** or **▼** button (6) to make further changes to the settings.

X-BASS

The X-BASS feature can be used to boost the bass at low volume levels.

Adjusting the X-BASS boost

The X-BASS boost (Level) can be set in steps ranging from 0 to 6 for one of the following frequencies: 32 Hz, 40 Hz, 50 Hz, 63 Hz or 80 Hz.

“LVL 0” means that no X-BASS boost will be applied, and “LVL 6” means that X-BASS will be boosted by the maximum amount.

⇨ Press the **AUD•DEQ** button (11).

“BASS” appears on the display.

⇨ Press the **▲** or **▼** button (6) repeatedly until “X-BASS” appears on the display.

⇨ Press the **MENU•OK** button (7).

The X-Bass menu is displayed. The frequency flashes.

⇨ Press the **▲** or **▼** button (6) to set the frequency that you want.

⇨ Press the **>** button (6).

The boost level (LVL) flashes.

⇨ Press the **▲** or **▼** button (6) to set the boost level that you want.

⇨ Press the **AUD•DEQ** button (11).

Equalizer

The device features a digital equalizer DEQ+.

This means you have three 5-band equalizers, six sound presets and seven vehicle presets at your disposal.

You can configure the EQ1 - EQ3 equalizers manually. When doing so you can adjust (boost or reduce) one frequency of an equalizer band as well as the quality factor, i.e. the width of the filter.

The following bands are available:

- LOW 1 20 - 250 Hz
- LOW 2 20 - 250 Hz
- HIGH 1 315 - 20,000 Hz
- HIGH 2 315 - 20,000 Hz
- HIGH 3 315 - 20,000 Hz

Switching the equalizer on/off

To switch the equalizer on/off,

⇨ press and hold down the **AUD•DEQ** button (11) for longer than two seconds.

The equalizer menu appears on the display.

To activate the equalizer,

⇨ select one of the sound presets or adjust the equalizer manually. For further details on this, please read the sections that follow in this chapter.

EQUALIZER

To deactivate the equalizer,

- ⇨ press the **▲** or **▼** button (6) repeatedly until “EQ OFF” appears on the display.
- ⇨ Press the **MENU•OK** button (7) and then the **DIS•ESC** (5).

Selecting sound presets

You can select sound presets for the following music types.

- POP
- ROCK
- TECHNO
- JAZZ
- CLASSIC
- SPEECH

The settings for these music styles have already been programmed.

- ⇨ Press and hold down the **AUD•DEQ** button (11) for longer than two seconds.
- ⇨ Press the **▲** or **▼** button (6) repeatedly until “SOUND PRESETS” appears on the display.
- ⇨ Press the **MENU•OK** button (7).
- ⇨ Press the **<** or **>** button (6) repeatedly until the sound preset that you want is displayed.
- ⇨ Press the **MENU•OK** button (7) and then the **DIS•ESC** (5).

The settings are saved.

Selecting vehicle presets

You can select optimised equalizer settings for the following vehicle types:

- COMPACT
- 4DOOR
- CONVERT
- VAN
- ROADSTER
- MINI
- TRUCK

The settings for these vehicle types have already been programmed.

- ⇨ Press and hold down the **AUD•DEQ** button (11) for longer than two seconds.
- ⇨ Press the **▲** or **▼** button (6) repeatedly until “CAR PRESETS” appears on the display.
- ⇨ Press the **MENU•OK** button (7).
- ⇨ Press the **<** or **>** button (6) repeatedly until the vehicle type that you want is displayed.
- ⇨ Press the **MENU•OK** button (7) and then the **DIS•ESC** (5).

The settings are saved.

Manually adjusting the equalizer

Notes on adjusting the settings

We recommend you use a CD that you are familiar with for making changes to the settings.

Before adjusting the equalizer, set the sound and volume distribution settings to zero and deactivate X-BASS. For further information, please read the "Sound" chapter.

- ⇨ Listen to the CD.
- ⇨ What kind of impression does the sound make?
- ⇨ Now read the "Sound impression" column in the table entitled "Help adjusting the equalizer".
- ⇨ Set the equalizer values as described in the "Measures" column.

Making adjustments

- ⇨ Press and hold down the **AUD•DEQ** button (11) for longer than two seconds.
- ⇨ Press the **▲** or **▼** button (6) repeatedly until "MANUAL EQ" appears on the display.
- ⇨ Press the **MENU•OK** button (7).
- ⇨ Press the **▲** or **▼** button (6) repeatedly until the equalizer that you want to configure ("USER EQ1", "USER EQ2" or "USER EQ3") appears on the display.
- ⇨ Press the **MENU•OK** button (7).
- ⇨ Press the **▲** or **▼** button (6) repeatedly until the equalizer band that you

want to configure ("LOW1", "LOW2", "HIGH1", "HIGH2" or "HIGH3") appears on the display.

- ⇨ Press the **MENU•OK** button (7).
- ⇨ Press the **▲** or **▼** button (6) repeatedly until the frequency that you want is displayed.
- ⇨ Press the **MENU•OK** button (7).

The top line displays the GAIN and the quality factor "Q". The gain setting flashes. You can use the quality factor to adjust the width of the filter. The higher you set the value for the quality factor the more directly the filter will be applied to the selected frequency.

To adjust the gain,

- ⇨ press the **▲** or **▼** button (6).

To adjust the quality factor,

- ⇨ press the **>** button (6).

The quality factor setting flashes.

- ⇨ Press the **▲** or **▼** button (6) repeatedly until the setting that you want is displayed.

Note:

- Please note that you can boost or reduce one frequency in each equalizer band. Proceed in the way described above with all the equalizer bands that you want to adjust.
- ⇨ Press the **MENU•OK** button (7) and then repeatedly the **DIS•ESC** button (5) or the **AUD•DEQ** button (11) for longer than two seconds.

The settings are saved.

EQUALIZER

Help adjusting the equalizer

Sound Impression / problem	Measures
Bass sound is too weak	Increase bass with Frequency: 32 to 160 Hz Gain: +4 to +6
Dirty bass Booming sound Unpleasant pressure	Reduce the lower mid level with Frequency: 400 Hz Gain: approx. -4
Sound very much in the foreground, aggressive, no stereo effect.	Reduce the mid level with Frequency: 1,000 to 2,500 Hz Gain: -4 to -6
Dull sound Little clarity No brilliance to the instruments	Boost the treble range with Frequency: 6,300 to 10,000 Hz Gain: +2 to +4

Adjusting the display settings

Adjusting the display brightness

If your car sound system is connected as described in the installation instructions, the display brightness switches with the headlights. You can adjust the display brightness separately for night and day in steps ranging from 1 - 16.

- ⇨ Press the **MENU•OK** button (7).
- ⇨ Press the **∨** or **∧** button (6) repeatedly until "DISPLAY MENU" appears on the display.
- ⇨ Press the **MENU•OK** button (7).
- ⇨ Press the **∧** or **∨** button (6) repeatedly until "DAY" or "NIGHT" appears on the display with the current setting.
- ⇨ Press the **<** or **>** button (6) to switch between the brightness levels.

When you have finished making your changes,

- ⇨ press the **MENU•OK** button (7) and then the **DIS•ESC** button (5) to exit the menu.

Adjusting the viewing angle

You can adjust the display's viewing angle to suit the installation position of the device in your vehicle.

- ⇨ Press the **MENU•OK** button (7).
- ⇨ Press the **∨** or **∧** button (6) repeatedly until "DISPLAY MENU" appears on the display.
- ⇨ Press the **MENU•OK** button (7).
- ⇨ Press the **∧** or **∨** button (6) repeatedly until "ANGLE" appears on the display with the current setting.
- ⇨ Press the **<** or **>** button (6) to adjust the viewing angle.

When you have finished making your changes,

- ⇨ press the **MENU•OK** button (7) and then the **DIS•ESC** button (5) to exit the menu.

EXTERNAL AUDIO SOURCES

External audio sources

In addition to the CD changer, you can also connect another external audio source equipped with a line output. If no CD changer is connected to the device, you can connect two external audio sources. Audio sources can, for example, be portable CD players, MiniDisc players or MP3 players.

The AUX input must be activated in the menu.

If you want to connect an external audio source, you will need an adapter cable. You can obtain this cable (Blaupunkt no.: 7 607 897 093) from your authorised Blaupunkt dealer.

Switching the AUX input on/off

- ⇒ Press the **MENU•OK** button (7).
- ⇒ Press the **V** or **Λ** button (6) repeatedly until “AUX MENU” appears on the display.
- ⇒ Press the **MENU•OK** button (7).
- ⇒ Repeatedly press the **V** or **Λ** button (6) until “AUX2” or “AUX1” appears on the display.

If a CD changer is connected, “AUX1” is not available.

- ⇒ Use the **<>** buttons (6) to switch between the “ON” and “OFF” options.

When you have finished making your changes,

- ⇒ press the **MENU•OK** button (7) and then the **DIS•ESC** button (5) to exit the menu.

Note:

- If the AUX input is switched on, you can select it by pressing the **SRC** button.

Amplifier

The car sound system provides connections that allow you to connect external amplifiers.

We recommend you use well-matched products from the Blaupunkt or Velocity product ranges.

Switching the internal amplifier on/off

If you are using external amplifiers, you can switch off the device's internal amplifier ("INT AMP OFF" setting).

Note:

- Please check this setting if the loudspeakers do not emit any sound.
- ⇒ Press the **MENU•OK** button (7).
- ⇒ Press the **V** or **▲** button (6) repeatedly until "VARIOUS MENU" appears on the display.
- ⇒ Press the **MENU•OK** (7), to display the menu.
- ⇒ Press the **V** or **▲** button (6) repeatedly until "INT AMP ON" or "INT AMP OFF" appears on the display.
- ⇒ Use the **<>** buttons (6) to choose between "INT AMP ON" and "INT AMP OFF".

When you have finished making your changes,

- ⇒ press the **MENU•OK** button (7) and then the **DIS•ESC** button (5) to exit the menu.

TMC for dynamic navigation systems

TMC stands for "Traffic Message Channel". Traffic reports are broadcast digitally via TMC, which means they can be used by compatible navigation systems during route planning. Your car sound system has a TMC output, which you can use for connecting Blaupunkt navigation systems. You can find out from your Blaupunkt dealer which navigation systems can be used with your car sound system.

If a navigation system is connected and a TMC sender is being received, the display shows TMC.

If dynamic navigation is active, the system will tune into a TMC station automatically.

SPECIFICATIONS

Specifications

Amplifier

Output power: 4 x 18 watts sine at
14.4 V and 1%
distortion factor
at 4 ohms.
4 x 26 watts sine in
accordance with
DIN 45324 at 14.4 V
at 4 ohms.
4 x 50 watts
max. power

Tuner

Wavebands:

FM : 87.5 - 108 MHz
MW : 531 - 1 602 kHz
LW : 153 - 279 kHz

FM frequency response:

35 - 16,000 Hz

DAB

BAND III (Europe):

174.928 MHz - 239.200 MHz

(Channel 5A - Channel 13F)

L-BAND (Europe):

1.452961 GHz - 1.490625 GHz

(Channel LA - Channel LW)

CD

Frequency response:

20 - 20,000 Hz

Pre-amp out

4 channels: 3 V

Input sensitivity

AUX input : 2 V / 6 kohm

Tel/Navi input : 10 V / 1 kohm

Subject to changes!

Bitte den ausgefüllten Gerätepass sicher aufbewahren!

Please keep the filled-in radio pass in a safe place!

Prière de conserver soigneusement la carte d'autoradio remplie !

Tenete per favore il libretto di apparecchio, debitamente riempito, in un posto sicuro!

Bewaar de ingevulde apparaatpas op een veilige plaats!

Vänligen förvara ifyllt apparatpass på säker plats!

¡Favor guardar el documento del aparato debidamente llenado en un lugar seguro!

Por favor, guardar o cartão preenchido do aparelho num lugar seguro!

Det udfyldte apparatpas opbevares et sikkert sted!

Country:	Phone:	Fax:	WWW:
Germany	(D) 0180-5000225	05121-49 4002	http://www.blaupunkt.com
Austria	(A) 01-610 39 0	01-610 39 391	
Belgium	(B) 02-525 5444	02-525 5263	
Denmark	(DK) 44 898 360	44-898 644	
Finland	(FIN) 09-435 991	09-435 99236	
France	(F) 01-4010 7007	01-4010 7320	
Great Britain	(GB) 01-89583 8880	01-89583 8394	
Greece	(GR) 210 94 27 337	210 94 12 711	
Ireland	(IRL) 01-46 66 700	01-46 66 706	
Italy	(I) 02-369 62331	02-369 62464	
Luxembourg	(L) 40 4078	40 2085	
Netherlands	(NL) 0800 400 1010	0800 400 1040	
Norway	(N) 66-817 000	66-817 157	
Portugal	(P) 2185 00144	2185 00165	
Spain	(E) 902 52 77 70	91 410 4078	
Sweden	(S) 08-7501850	08-7501810	
Switzerland	(CH) 01-8471644	01-8471650	
Czech. Rep.	(CZ) 02-6130 0446	02-6130 0514	
Hungary	(H) 76 511 803	76 511 809	
Poland	(PL) 0800-118922	022-8771260	
Turkey	(TR) 0212-335 06 71	0212-346 00 40	
USA	(USA) 800-2662528	708-6817188	
Brasil			
(Mercosur)	(BR) 0800 7045446	+55-19 3745 2773	
Malaysia			
(Asia Pacific)	(MAL) +604-6382 474	+604-6413 640	

Gerätepass

Name: **Nashville DAB35**

Typ: **7 645 660 310**

Serien-Nr: **BP**

 **BLAUPUNKT**

Blaupunkt GmbH, Robert-Bosch-Straße 200, D-31139 Hildesheim



(DE) Hinweis zum PTY-EON-Empfang

Wenn Ihr Blaupunkt-Gerät von einem gehörten Radioprogramm zu einem anderen Radioprogramm oder von einer gewählten Quelle (CD oder CD-Wechsler) zu einem Radioprogramm umschaltet, so überprüfen Sie bitte, ob Sie PTY (Programm-Typ) eingeschaltet haben.

Möchten Sie diese PTY-EON-Umschaltung nicht haben, so schalten Sie diese im Menü mit „PTY off“ aus. Drücken Sie zuvor eine der Tasten AUDIO, SRC oder BND.

Bitte lesen Sie dazu auch in der Bedienungsanleitung unter „Radiobetrieb“ den Absatz „Programm-Typ (PTY)“.

(GB) Note regarding PTY-EON reception

If your Blaupunkt system switches from your chosen radio programme to another radio programme or from your chosen audio source (CD or CD changer) to a radio programme, please check whether you have activated the PTY (programme type) function.

If you do not want this PTY-EON switching to occur, you should deactivate it in the menu by selecting “PTY off”. Press one of the AUDIO, SRC or BND buttons beforehand.

Please also read about this in the operating instructions in the section entitled “Programme type (PTY)” under “Radio mode”.

(FR) Remarque concernant la réception PTY EON

Quand votre appareil Blaupunkt commute d'une émission de radio que vous êtes en train d'écouter à un autre programme radio ou d'une source (CD ou changeur CD) que vous avez choisie, assurez-vous d'avoir activé PTY (type de programme).

Si vous ne souhaitez pas cette commutation PTY EON, désactivez-la en sélectionnant « PTY off » dans le menu. Appuyez au préalable sur l'une des touches AUDIO, SRC ou BND.

Pour plus d'informations, reportez-vous également au paragraphe « Type de programme (PTY) » du chapitre « Mode radio » du mode d'emploi.

(IT) Nota sulla ricezione del PTY-EON

Quando il vostro apparecchio Blaupunkt si sintonizza da un radioprogramma in ascolto ad un altro, oppure si disinserisce dalla fonte audio selezionata (CD o multilettores CD) e passa alla ricezione di un programma radio, controllate per favore se avete inserito la funzione PTY (tipo di programma).

Se volete evitare queste commutazioni PTY-EON, selezionate nel menu la funzione "PTY off". Prima di fare ciò premete uno dei tasti AUDIO, SRC o BND.

Leggete per favore a tale proposito quanto riportato nelle istruzioni d'uso nella sezione "Esercizio Radio" al punto "Tipo di programma (PTY)".

(NL) Aanwijzing bij de PTY-EON-ontvangst

Wanneer uw Blaupunkt-apparaat van één beluisterde radiozender overschakelt op een andere, of van een gekozen geluidsbron (cd of cd-wisselaar) op een radiozender, kunt u controleren of u PTY (programmatype) hebt ingeschakeld.

Wanneer u geen prijs stelt op deze PTY-EON-omschakeling, schakelt u deze in het menu uit met "PTY off". Druk van tevoren op een van de toetsen AUDIO, SRC of BND.

Lees hiervoor ook in de gebruiksaanwijzing onder "Radioweergave" de alinea "Programmatype (PTY)".

(SW) Information om mottagning med PTY-EON

Byter din Blaupunkt bilstereo självmant från inställt radioprogram eller spelad cd/cd-växlare till annat radioprogram? Då är möjligen funktionen Programtyp (PTY-EON) tillkopplad.

Om Du vill undvika detta, frånkopplar Du funktionen Programtyp (PTY-EON) i menyn. Tryck först på någon av knapparna AUDIO, SRC eller BND och välj sedan "PTY off".

För mer information, se avsnittet "Programtyp (PTY)" i bruksanvisningens kapitel "Radio".

(ES) Observaciones sobre la recepción PTY-EON

Si su equipo Blaupunkt cambia de la emisora de radio que está escuchando a otra, o de la fuente de sonido seleccionada (CD o cambiadiscos) a una emisora de radio, verifique si tiene activada la función PTY (tipo de programa).

Si no desea que el equipo cambie automáticamente a emisoras PTY-EON, desactive dicha función seleccionando la opción "PTY off" en el menú. Pulse previamente una de las teclas AUDIO, SRC o BND.

Para más detalles, consulte el punto "Tipo de programa (PTY)" en el capítulo "Modo de radio" de las instrucciones de manejo.

(PT) Informação sobre a recepção no modo PTY-EON

Se o seu aparelho mudar de um programa para outro programa ou de uma fonte que está a ouvir actualmente (CD ou CDC) para um programa radiofónico, verifique se a função PTY (tipo de programa) está activada.

Se não desejar usar a função PTY-EON, desactive-a no menu escolhendo a opção "PTY OFF". Prima anteriormente uma das teclas AUDIO, SRC ou BND.

Para tal, leia também o parágrafo "Tipo de programas (PTY)" no capítulo "Rádio" nas instruções de serviço.

(DK) Oplysning om PTY-EON-modtagelse

Hvis din Blaupunkt radio slår fra det aktuelle radioprogram over i et andet eller fra en valgt kilde (CD eller Multi CD) over i et radioprogram, bør du tjekke om du har tændt for PTY (programtype).

Hvis PTY-EON-omsiftningen ikke ønskes, deaktiveres funktionen med "PTY off" i menuen. Forinden trykkes på en af tasterne AUDIO, SRC eller BND.

Læs også afsnittet om "Programtype (PTY)" under "Radiodrift" i betjeningsvejledningen.

(SF) PTY-EON-vastaanottoon liittyvä ohje

Jos Blaupunkt-laite vaihtaa kuuntelemastasi radio-ohjelmasta toiseen radio-ohjelmaan tai valitsemastasi äänilähteestä (CD tai CD-vaihtaja) johonkin radio-ohjelmaan, tarkista onko PTY (ohjelmatyypin tunnustus) päällä.

Jos et halua laitteen vaihtavan radio-ohjelmaa automaattisesti PTY-EON-toiminnon avulla, voit kytkeä sen pois toiminnasta valikossa ("PTY off"). Paina ensin jotain painikkeista AUDIO, SRC tai BND.

Lue myös käyttöohjeen kohdasta "Radiokäyttö" kappale "Ohjelmatyypit (PTY)".

(PL) Wskazówki dotyczące odbioru PTY-EON

Gdy urządzenie przełącza się z jednej stacji radiowej na inną lub z wybranego źródła audio (CD / zmieniacz CD) na odbiór programu radiowego, to należy sprawdzić, czy włączony program jest programem typu PTY.

Jeżeli nie chcą Państwo korzystać z funkcji PTY EON, to proszę w odpowiednim menu wybrać opcję „PTY off”. Przed wybraniem tej opcji trzeba wcisnąć jeden z przycisków AUDIO, SRC lub BND.

Dalsze informacje na ten temat znajdują Państwo w instrukcji obsługi w rozdziale „Tryb obsługi radia”, w punkcie „Typ programu (PTY)”.

(CZ) Upozornění k příjmu s funkcí PTY-EON

Pokud se váš přístroj přepne ze stanice, kterou právě posloucháte, na jinou rozhlasovou stanici, nebo ze zvoleného zdroje (CD nebo měnič CD) na jiné rozhlasové vysílání, zkontrolujte, jestli není zapnutá funkce PTY (typ programu).

Pokud si nepřejete, aby došlo k přepínání přístroje funkcí PTY-EON, vypněte ji v nabídce bodem „PTY off“. Stiskněte nejprve jedno z tlačítek AUDIO, SRC nebo BND.

Bližší informace k tomuto bodu naleznete v návodu k obsluze v kapitole „Režim rádia“ v odstavci „Typ programu (PTY)“.

(HU) Utasítás a PTY-EON vételhez

Ha az Ön Blaupunkt készüléke egy hallgatott rádióműsorról egy másik rádióműsorra vagy egy kiválasztott forrásról (CD vagy CD-váltó) egy rádióműsorra kapcsol át, úgy kérjük ellenőrizze, hogy bekapcsolta-e a PTY-t (műsortípus).

Ha Önnek nem megfelelő ez a PTY-EON átkapcsolás, kérjük, kapcsolja azt ki a menüben a „PTY off“-fal. Előtte azonban nyomja le az AUDIO, SRC vagy BND gombok egyikét.

Kérjük, ezzel kapcsolatban olvassa el a kezelési útmutató „Rádió üzemmód” fejezetében a „Műsortípus (PTY)” c. bekezdést.

(KR) Napomena uz PTY-EON-prijem

Ako Vaš Blaupunkt uređaj prebacuje sa jednog radio-programa na neki drugi ili sa jednog izabranog izvora (CD ili CD-izmenjivač) na neki radio-program, onda molimo da proverite, da li ste uključili PTY (tip programa).

Ako ne želite ovo PTY-EON-prebacivanje, onda ga isključite u meniju sa „PTY off“. Prethodno pritisnite jednu od tipki AUDIO, SRC ili BND.

Molimo Vas, o tome pročitajte i u uputama za upotrebu pod „Rad radija” poglavlje „Tip programa (PTY)“.

(SE) Napomena uz PTY-EON-prijem

Ako Vaš Blaupunkt uređaj prebacuje sa jednog radio-programa na neki drugi ili sa jednog izabranog izvora (CD ili CD-izmenjivač) na neki radio-program, onda molimo da proverite, da li ste uključili PTY (tip programa).

Ako ne želite ovo PTY-EON-prebacivanje, onda ga isključite u meniju sa „PTY off“. Prethodno pritisnite jedan od tastera AUDIO, SRC ili BND.

Molimo Vas, o tome pročitajte i u uputstvu za upotrebu pod „Rad radija” pasus „Tip programa (PTY)“.

(SK) Pokyny pre príjem PTY-EON

Ak Váš prístroj Blaupunkt prepína z počúvaného rádioprogramu na iný rádioprogram alebo z niektorého zvoleného zdroja (CD alebo meniča CD) na iný rádioprogram, tak prosím skontrolujte, či ste zapnuli PTY (Program Type).

Ak nechcete toto prepínanie PTY-EON, vypnite ho v menu pomocou "PTY off". Stlačte pred tým niektoré z tlačidiel AUDIO, SRC alebo BND.

Prečítajte si prosím k tomu tiež v návode na obsluhu, pod "Rádiová prevádzka" odsek "Program Type (PTY)".

(SL) Navodilo za PTY-EON sprejem

Ko se Vaša Blaupunkt naprava preklopi iz slušnega radijskega programa na drugi radijski program, oziroma iz izbrane zveze (CD ali CD-menjalca) na radijski program, Vas prosimo, da preverite, če ste vklopili PTY (programni-tip).

Če nočete preklon PTY-EON, potem priklopite le-tega v meniju na „PTY off“. Pritisnite pred tem na tipko AUDIO, SRC oziroma na BND.

Prosimo, da si preberete v navodilih za uporabo pod "radijo delovanje" odstavek "program-tip (PTY)".

(TR) PTY-EON yayını alınması ile ilgili bilgi

Eğer Blaupunkt cihazınız dinlediğiniz bir radyo programından başka bir radyo programına veya seçmiş olduğunuz bir kaynaktan (CD veya CD değiştirici) bir radyo programına geçerse, PTY (program tipi) fonksiyonunu açmış olup olmadığınıza lütfen kontrol ediniz.

Eğer bu PTY-EON geçişini istemiyorsanız, bu fonksiyonu menü üzerinden "PTY off" ile kapatınız. Bu işlem den önce AUDIO, SRC veya BND tuşlarından birine basınız.

Lütfen bu konu ile ilgili olarak, kullanma kılavuzunda "Radyo modu" bölümündeki "Program tipi (PTY)" kısmını okuyunuz.

(GR) Υπόδειξη για τη λήψη PTY-EON

Όταν η συσκευή σας Blaupunkt αλλάζει από ένα ραδιοφωνικό πρόγραμμα που ακούτε σε ένα άλλο ραδιοφωνικό πρόγραμμα ή από μια επιλεγμένη πηγή (CD ή τροφοδότης CD) σε ένα ραδιοφωνικό πρόγραμμα, τότε ελέγξτε παρακαλώ, εάν έχετε ενεργοποιήσει το PTY (τύπος προγράμματος).

Όταν δεν επιθυμείτε να έχετε αυτή την αλλαγή λειτουργίας PTY-EON, τότε απενεργοποιήστε την στο μενού με "PTY OFF". Πατήστε προηγουμένως ένα από τα πλήκτρα AUDIO, SRC ή BND.

Διαβάστε παρακαλώ γι' αυτό επίσης στις οδηγίες χειρισμού κάτω από "Λειτουργία ραδιοφώνου" την ενότητα "Τύπος προγράμματος (PTY)".

(RU) Указание по приемуPTY-EON

При переключении тюнера аппарата Blaupunkt на другую радиостанцию или переключении с радиоприема на другой источник звука (проигрыватель CD или CD-чейнджер) проверьте, пожалуйста, включена ли функцияPTY (тип программы). Если Вы хотите отключить автоматический выбор программPTY-EON, то выключите эту функцию опцией меню "PTY off". Для этого нажмите одну из следующих клавиш – AUDIO, SRC или BND.

Ознакомьтесь, пожалуйста, с соответствующими инструкциями о включении автоматического режима выбора программ (PTY) в разделе "Прием радиопередач" пользовательской документации к Вашему аппарату Blaupunkt.