

SYSTEM 238 Installation Manual

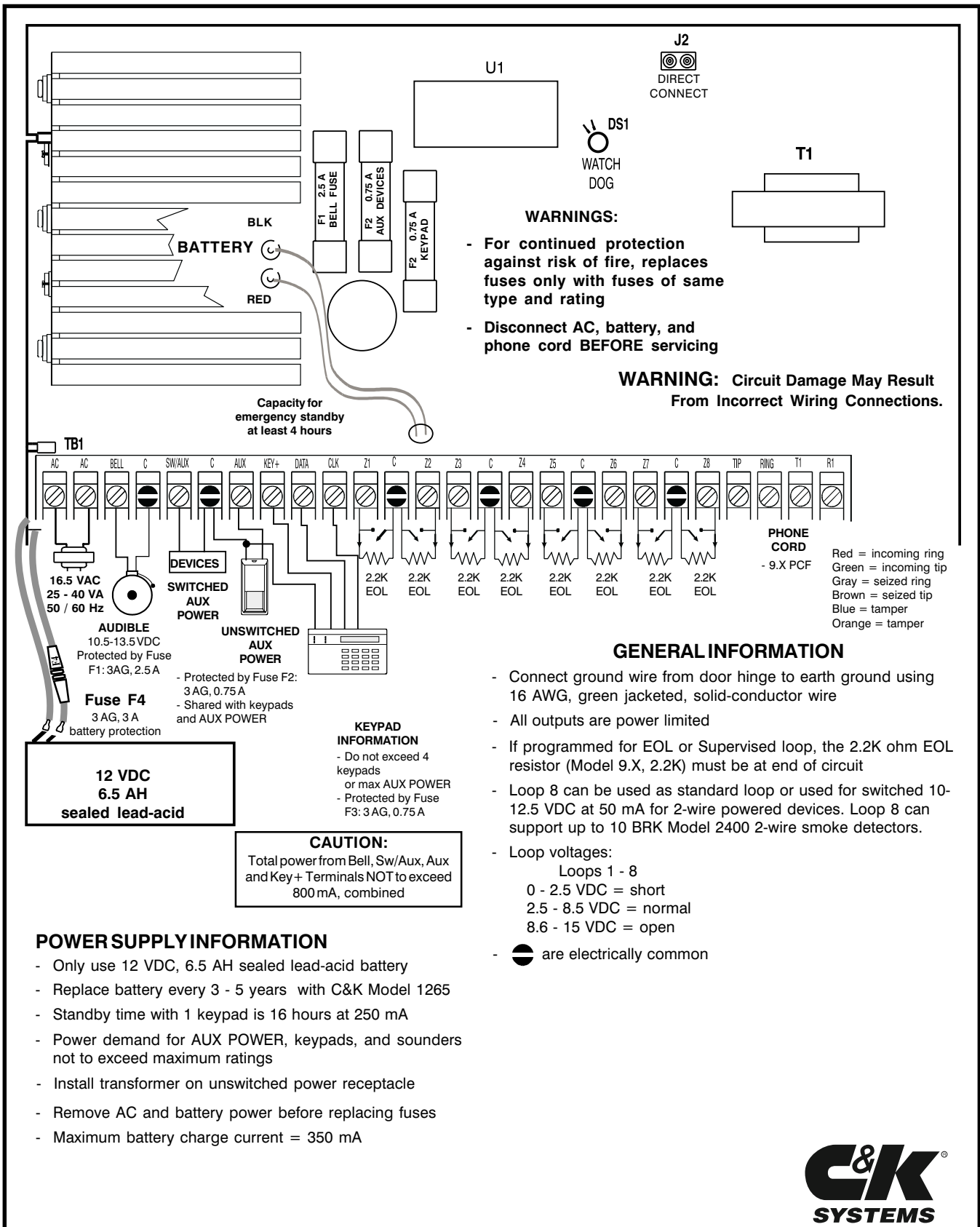

- WARNINGS:**
- For continued protection against risk of fire, replaces fuses only with fuses of same type and rating
 - Disconnect AC, battery, and phone cord **BEFORE** servicing

WARNING: Circuit Damage May Result From Incorrect Wiring Connections.

GENERAL INFORMATION

- Connect ground wire from door hinge to earth ground using 16 AWG, green jacketed, solid-conductor wire
- All outputs are power limited
- If programmed for EOL or Supervised loop, the 2.2K ohm EOL resistor (Model 9.X, 2.2K) must be at end of circuit
- Loop 8 can be used as standard loop or used for switched 10-12.5 VDC at 50 mA for 2-wire powered devices. Loop 8 can support up to 10 BRK Model 2400 2-wire smoke detectors.
- Loop voltages:
 - Loops 1 - 8
 - 0 - 2.5 VDC = short
 - 2.5 - 8.5 VDC = normal
 - 8.6 - 15 VDC = open
- are electrically common

POWER SUPPLY INFORMATION

- Only use 12 VDC, 6.5 AH sealed lead-acid battery
- Replace battery every 3 - 5 years with C&K Model 1265
- Standby time with 1 keypad is 16 hours at 250 mA
- Power demand for AUX POWER, keypads, and sounders not to exceed maximum ratings
- Install transformer on unswitched power receptacle
- Remove AC and battery power before replacing fuses
- Maximum battery charge current = 350 mA

CAUTION:
Total power from Bell, Sw/Aux, Aux and Key+ Terminals NOT to exceed 800 mA, combined

KEYPAD INFORMATION
- Do not exceed 4 keypads
- or max AUX POWER
- Protected by Fuse F3: 3 AG, 0.75 A

**12 VDC
6.5 AH
sealed lead-acid**



Table of Contents

Subject	Page No.
System 238 Terminal Label	Front Cover
Residential and Commercial Installation Guidelines	2
Installation	2 - 3
Wiring the Panel	3 - 4
System Start-Up	4
Keypad Setup	4 - 5
Addressing Keypads	5
Factory Default Settings	5
Programming Options (Alphabetical List)	5 - 6
Programming the Panel	6
Programming with the LED Keypad	6
Programming with the Alpha Keypad	6
Entering Hexadecimal Numbers	6
Programming the Alpha Keypad	6 - 7
Programming Letters & Numbers	7
Special Function Keys	7
Programming Options (Numerical Order)	8 - 18
Keypad Label Drawer	19
Telephone Line Problems	19
Watchdog Indicator	19
Keypad Operation Command Summary	20
Help with Common Problems (Troubleshooting)	21 - 22
Reducing False Alarms	23 - 24
Programming Worksheets	26 - 27

BEFORE YOU START

Scope of This Manual

This manual contains basic installation and programming information for the SYSTEM 238. For additional information about using or programming the system, please refer to the SYSTEM 238 Keypad Manual, Alpha Keypad Manual, or Commander II/Monitor II Operating Manual.

Accuracy

This manual has been carefully checked for accuracy. However, C&K SYSTEMS assumes no liability for inaccuracies or actions resulting from the use of this manual. In addition, C&K reserves the right to modify the SYSTEM 238 hardware, software, and manuals without prior notice.

Residential Configuration

The following list of options are recommended for a standard SYSTEM 238 installation in a residential environment:

1. Program the audible to sound for at least four minutes before silencing.
2. No zones should be programmed for silent alarm.
3. Fire zones should be programmed for Temporal Code 3 audible alarm.
4. Burglar zones should be programmed for a steady audible.
5. Burglar loops should be programmed for EOL.
6. Entry Delay should not be greater than 45 seconds.
7. Exit Delay should not be greater than 60 seconds.
8. The Dynamic Battery Test should be enabled.
9. The Unit Status Report should be enabled.
10. The 24-hour Check-in (Test Report) should be enabled.
11. The communicator should not be programmed for Delay Before Dial.

12. The system must not be programmed to dial a police station.
13. Use screws (supplied) to secure cover or install a lock on the cabinet.
14. Loop Response Time should be set to 500mS.

The following additional options are recommended for commercial installations.

1. The audible should be programmed to sound at least 15 minutes before silencing.
2. The ring-back function should be activated.
3. The control panel should be mounted in an enclosure that is:
 - (a) Attack-resistant (C&K Model # 2330-UAC)
 - (b) Secured with a key-lock and six (6) #6 X 1¼" sheet metal screws.
 - (c) Tamper protected against cabinet door opening and removal from mounting surface.
 - (d) For safe and vault applications the control panel must be monitored by a UL Listed shock sensor suitable for the protection of sheet metal enclosures.
4. The Ademco Model AD10-12 bell with Model AB bell housing should be used.
5. The power and tamper wiring between the bell and the control panel should be completely enclosed in rigid conduit or electric metallic tubing for a Grade A system or flexible conduit for a Grade B system.
6. Zone(s) monitoring tamper circuitry should be 24 hour and non-shunttable.

Zone Programming

- | FIRE LOOP | BURGLAR LOOP |
|----------------------------|----------------------------|
| • No Delay Before Dial | • No Delay Before Dial |
| • 24-hour arming | • NO/NC with EOL |
| • Pulsing audible | • Steady audible |
| • Supervised | • 500mS Loop Response Time |
| - latching for heat | |
| - resetting for smoke | |
| • Not shunttable | |
| • 500mS Loop Response Time | |

INSTALLATION

Mounting

The SYSTEM 238 should be mounted in a location which allows convenient access to AC power, telephone connections, and earth ground.

- Remove the circuit board from the cabinet. This will prevent possible damage to the PCB when removing the knock-outs.
- Remove the knock-outs, as required.
- Mark the screw mounting holes on the wall.
- Mount the cabinet at the desired height and pass the cables through the knock-outs.
- Replace the circuit board, remembering to connect the ground lug to the lower left corner of the circuit board.
- Reconnect the spade lug to the lower door hinge. This provides the earth ground connection for the door.

Earth Ground

To ensure the effectiveness of the lightning and transient protection circuits, the control panel must be connected to "Earth Ground". Ideally, this should be a common ground to the power lines, telephone system, and security system. This type of ground, called a "Unified Earth Ground", provides the best protection. The ground connection, from a grounding rod, cold water pipe or other established ground point, is made to the green jacketed wire providing a ground to the panel housing.

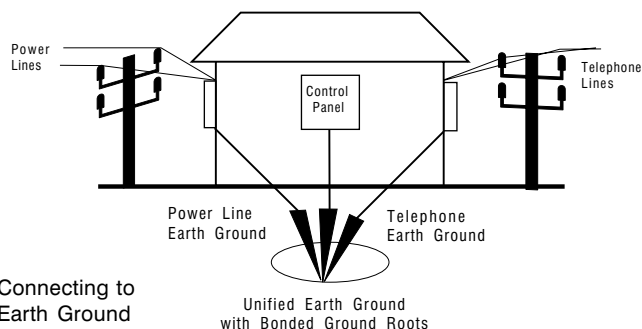

Connecting to Earth Ground

WIRING THE PANEL

Standby Battery

The SYSTEM 238 is designed to operate with a 12 volt, 6.5 Ah, sealed lead-acid battery (C&K Model 1265). Do not use non-rechargeable batteries or batteries other than sealed lead-acid. **It is recommended that you replace the standby battery every three to five years.**

Connect the red lead to the battery positive terminal and the black lead to the battery negative. The battery is reverse-polarity protected by a 3 AG, 3 amp, fast-blow fuse (F4).

AC POWER

Terminal Label:
AC



AC power is supplied by a 16.5 VAC, 25 - 40 VA transformer at 50 or 60 Hz. The transformer must be a UL listed Class 2 transformer. Connect the secondary of the transformer to the terminals labelled AC. Use at least 18 AWG (1.02 mm) wire to reduce voltage drops. **The primary side of the transformer must be connected to an unswitched receptacle. Do not connect primary to Ground-Fault-Interrupt (GFI) circuits.** Secure the transformer to the wall.

AC power is supplied by a 16.5 VAC, 25 - 40 VA transformer at 50 or 60 Hz. The transformer must be a UL listed Class 2 transformer. Connect the secondary of the transformer to the terminals labelled AC. Use at least 18 AWG (1.02 mm) wire to reduce voltage drops. **The primary side of the transformer must be connected to an unswitched receptacle. Do not connect primary to Ground-Fault-Interrupt (GFI) circuits.** Secure the transformer to the wall.

AC Power Failure

If an AC power failure lasts more than 15 minutes, the keypads will display a system trouble. An AC failure report will be sent, if programmed. When AC is restored for five minutes, a restoral report will be sent.

Precautions

- Do not share the secondary of the transformer with other devices. A foreign ground can damage the power supply, voiding the warranty.**
- Do not use any transformer other than that specified in the AC POWER section above.**

Available Power

The maximum total power available from the **Audible**, **AUX (Switched and Unswitched)**, and **Keypad** is 800 mA. The switched auxiliary, unswitched auxiliary, and keypads share the same power bus. Combined power for these outputs should not exceed 500 mA.

NOTE: The 50 mA switched power available on Loop 8 is part of the total 500 mA AUX power.

AUDIBLE OUTPUT

Terminal Label:
BELL & C

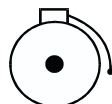

The BELL terminal provides up to 1.3 amps at 10.5 - 13.5 VDC. The type of voltage (steady, pulsed, chirp) and the time is programmable.

Fuse F1

The BELL terminal is protected by a 2.5 amps, 3 AG fast-blow fuse (F1).

NOTE: If any fuse opens, remove AC and DC power, remove the short or overload condition, then replace the fuse before restoring power. Do not substitute a higher rated fuse.

Electromagnetic Interference

Vibrating horns can produce electromagnetic interference (EMI). While EMI will not damage the SYSTEM 238, it can cause transmission errors and mis-dialing. To minimize EMI, install a 0.01 mfd, 100 volt capacitor across the terminals of the horn. The capacitor must be located in the horn.

AUXILIARY POWER

Terminal Labels:
SW/AUX, C & AUX

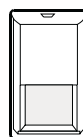

The **SW/AUX** terminal provides positive 10 - 12.5 VDC power for devices that require switched power for resetting. Typical devices are glass-break and smoke detectors.

The **C** terminal provides power common.

The **AUX** terminal supplies uninterrupted positive power.

Fuse F2

The **SW/AUX** and **AUX** terminals are protected by a 0.75 amp, 3 AG, fast-blow fuse (F2).

ARMING STATIONS

Terminal Labels:
C, KEY+, DATA, & CLK



The **KEY+** terminal (red) provides 11 - 14 VDC keypad power.

The **DATA** terminal (green) is data from the keypad to the panel.

The **C** terminal (black) is common.

The **CLK** terminal (white) is the clock line.

Connect the keypad to the System 238 control panel as shown in the diagram at the top of the next page.

Maximum wire length for connecting any keypad is 500' (152 m) of 22 AWG (0.643 mm) copper wire.

Keypad Wiring

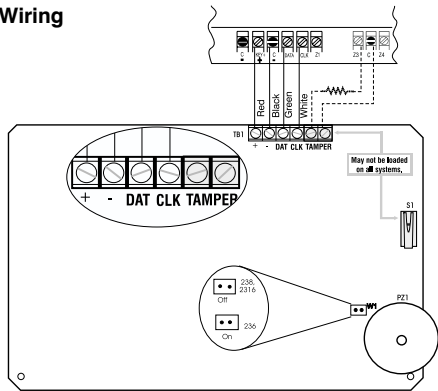

Connect the keypad to the control panel as shown in the diagram above. The Alpha Plus keypad also has a jumper, located near the piezo, that must be removed when used with the System 238 control panel.

The SYSTEM 238 is capable of addressing up to 8 Alpha keypads. LED keypads do not require addressing. Each LED keypad uses 35 mA of current. Each LCD keypad uses 64 mA of current. See **Available Power** for current limitations. See page 5 for additional information on keypad setup.

Fuse F3

The KEY+ terminal is protected by a 0.75 amp, 3 AG, fast-blow fuse (F3).

LOOP INPUTS

Terminal Labels: Z 1 - Z 8 & C

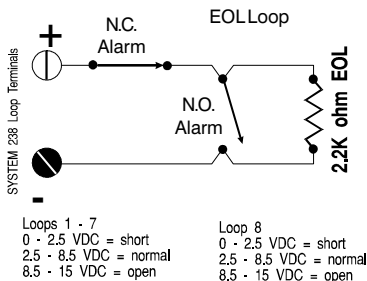
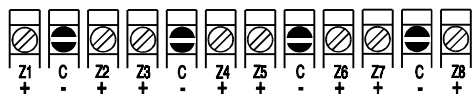

Each loop is independently configured through programming. Loops can be wired with an open circuit switch, or closed circuit switch, or with a 2.2K ohm end-of-line (EOL) resistor.

When programmed as EOL, either an open or a short will be reported as an alarm if the system is in an armed state.

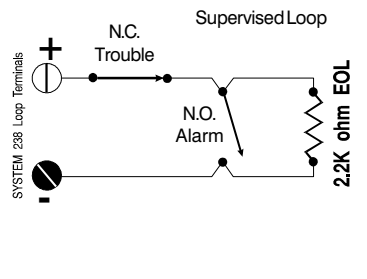

When operated as a Supervised Loop, an open will be reported as a Trouble. Whether the system is armed or disarmed. A short on a Supervised Loop will be reported as an alarm if the system is armed, but will have no effect if the system is disarmed.

Loop 8

Terminals C and Z8 are a standard loop that can also power 2-wire devices. It supplies 10 - 12.5 VDC at 50 mA. Use Loop 8 to power 2-wire glass-breaks and smoke detectors.

TAMPER SWITCH INSTALLATION

C&K has designed the SYSTEM 238 cabinet to use the **Ademco Model 19** tamper switch. The cabinet is constructed in order to accommodate two switches. One tamper for the cover and a second switch for a wall tamper. To install the tamper switches:

1. Position the tamper switch inside the cabinet at the lower right corner of the cabinet. For the wall tamper, the plunger should go through the small hole in the back of the cabinet. For the door tamper, the plunger should face out from the cabinet. **Refer to the drawing below.**
2. Connect the tamper switches in series and wire the tamper terminals to a dedicated zone of the control panel.
3. Program the dedicated zone as desired: NC, EOL, 24-hour, etc.

Once the tamper switches are installed, opening the cabinet door or removing the cabinet from the wall will result in a tamper signal at the panel.

Tamper Switches installed in the SYSTEM 238 cabinet

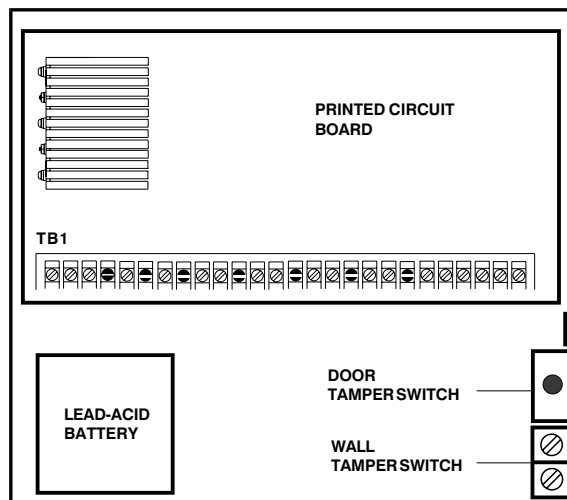

TELEPHONE INTERFACE

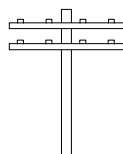

Connect the SYSTEM 238 to the phone line using the 9.X PCF cord (not included). The cord has an 8-pin telco plug on one end. Plug the telco end directly into the phone companies RJ31 or RJ38X jack. Connect the flying leads to the SYSTEM 238 PCB as shown below and listed on the next page.

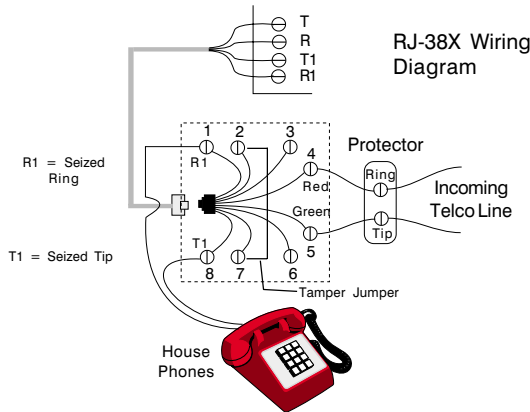

9.X PCF

The 9.X PCF has eight flying leads. Wire them to the PCB terminals as follows:

RED = ring	BROWN = tip seized
GREEN = tip	BLUE and ORANGE = tamper
GRAY = ring seized	YELLOW and BLACK = not used

SYSTEM START-UP

Five minutes after the panel is powered up, it will dynamically test the standby battery by interrupting AC power for two minutes and monitoring the battery under load.

Standby Battery Time with One LED Keypad

AUX POWER DRAIN*	STANDBY TIME
50 mA	32 hours
150 mA	24 hours
250 mA	16 hours
500 mA	10 hours

* Total power for all keypads, auxiliary, and Loop 8

If you replace the battery after a SYSTEM TROUBLE - LOW BATTERY message, you must test the battery under load conditions. Press [*] [6] [4] [#] to start the Dynamic Battery Test.

Voltage Variations

Output voltages at the Sw/AUX, AUX, and KEY+ terminals may vary between 9.0 and 14.4 VDC (worst case), depending on the load, battery condition, and AC line voltage.

KEYPAD SETUP

ALPHA KEYPAD INFORMATION

The Alpha keypad uses a top viewing display. This means the display reads most clearly when viewed from a top angle rather than straight on or from below. Mounting the keypad at the light switch level and adjusting the viewing angle gives the best viewing results.

Adjusting the LCD Display

To adjust the viewing angle, remove the keypad from the back mounting plate. Towards the bottom center of the circuit board is a small hole. Insert a small screwdriver into the hole and adjust **R23**, while holding the keypad at its mounting height. Adjust the potentiometer as necessary for optimum viewing.

Addressing Keypads

Each Alpha keypad installed in the system must have an address. **Addresses must not be repeated.** When replacing a keypad, make sure the replacement keypad has the same address as the previous keypad.

The first time you power up the system, unaddressed Alpha keypads will display **KEYPAD ADDRESS?**. Press any number from 0 through 7 at each keypad. The exact number you press is not important as long as each keypad has a different address number. The keypad will not accept values outside of the specified range. Should you accidentally use the same address for more than one keypad, the system will fail to properly respond to the keypad input. Refer to page 23 for assistance in correcting this problem.

Once all keypads have been addressed, reset the panel by pressing [Master Combination] [*] [6] [8] [#] or by temporarily removing both AC and DC power.

FACTORY SETTINGS

DEFAULT PROGRAM SETUP

The default programming of the SYSTEM 238 will allow you to operate it as a local panel without any additional programming. The actual default programming values are shown on the Programming Worksheet (last 2 pages of this manual).

Note: If you connect power before wiring the loops, install a 2.2K EOL resistor across each loops.

Combinations

Installer combination: 0 1 2 3 4 5
 User #1 (Master) combination: 1 2 3 4
 Users #2 - 8: disabled
 Default installer combination: yes
 Guest combination: no
 Combination required: no
 Arming type: goof-proof
 Opening/Closing: disabled
 Duress: disabled

Reporting

Account #1 and #2: disabled
 Dialing type: pulse
 RPS allowed: yes

Zones

Zone 1 = Entry/Exit delay - EOL circuit
 Zone 2 = doors or windows - EOL circuit
 Zone 3 = doors or windows - EOL circuit
 Zone 4 = doors or windows - EOL circuit
 Zone 5 = interior - EOL circuit
 Zone 6 = interior - EOL circuit
 Zone 7 = 24-hour panic or tamper - EOL circuit
 Zone 8 = fire or smoke - supervised EOL circuit
 Emergency soft zone: chirp audible
 Fire soft zone: pulsed audible
 Police soft zone: steady audible

Testing

Test report interval: 7 days and disabled

Timing

Entry time: 60 seconds and prewarn
 Exit time: 30 seconds and prewarn
 Bell time: 5 minutes

Unit Control

Local system: yes
 Dynamic battery test: off

PROGRAMMING OPTIONS

The following is an alphabetical listing of all SYSTEM 238 programming options, including Command Locations and Digit Positions. Digit Positions are inside parentheses ().

Option	Location
Account #1	0C (1-6)
Account #2	10 (1-6)
Alarm Code by Loop	17 - 1E (1-2)
Alarm Loop Shunting by Loop	30 - 37 (2)
Alarm Receiver Select by Loop	1F - 26 (1)
Audible Time	2D (5)
Audible Type by Loop	1F - 26(5)
Bell Reverse Operation	2E (3)
Cancel Receiver Select	2A (6)
Cancel Report Code	2A (5)
Closing Report Code	2C (3)
Closing Report Receiver	2C (4)

Option	Location
Combination Command	09 (2)
Daily Battery Test Enable	2F (2)
Delay Before Dial by Loop	30 - 37 (4)
Delay Before Dial Time	0B (1)
Dial Attempts	0B (6)
Dial Type	0B (2)
Disable Loop LEDs	2E (5)
Door Chime Enable by Loop	30 - 37 (1)
Duress Report Code	2D (1)
Duress Report Receiver	2D (2)
Emergency Bell Type	27 (4)
Emergency Report Code	27 (1 - 2)
Emergency Receiver Select	27 (3)
Entry Delay Time	2D (3)
Entry Pre-alarm Enable	2E (1)
Exit Delay Time	2D (4)
Exit Pre-alarm Enable	2E (2)
Faulted Arming Type	09 (4)
Fire Bell Type	28 (4)
Fire Report Code	28 (1 - 2)
Fire Receiver Select	28 (3)
Four Minute Power Up Delay Enable	2F (3)
Group Shunt Enable	30 - 37 (3)
Guest Combination	08 (2 - 6)
Guest Combination Time	09 (1)
Installer Combination	00 (1 - 6)
Keypad RPS Enable	0B (3)
Local System Only	2F (1)
Loop Arming Type	1F - 26 (4)
Loop Audible Type	1F - 26 (5)
Loop Circuit Type	1F - 26 (6)
Loop Receiver Select	1F - 26 (1)
Loop Response Time	1F - 26 (2)
Loop Restore Type	1F - 26 (3)
Master Code (User #1)	01 (2 - 6)
Opening Report Code	2C (1)
Opening Report Receiver	2C (2)
Police Bell Type	29 (4)
Police Report Code	29 (1 - 2)
Police Receiver Select	29 (3)
Phone Ring Type	0B (5)
Receiver #1 Message Format	0A (2)
Receiver #1 Phone Number	0D - 0F (1 - 6)
Receiver #1 Receive Format	0A (1)
Receiver #2 Message Format	0A (4)
Receiver #2 Phone Number	11 - 13 (1 - 6)
Receiver #2 Receive Format	0A (2)
Restoral Reporting Code by Loop	17 - 1E (3 - 4)
Restore Receiver Select	2A (2)
Ring Back Enable	2E (4)
RPS Enable	0B (4)
RPS Phone Number	14 - 16 (1 - 6)
Set Test Report Countdown Timer	A0 (1)
Shunt Enable	30 - 37 (2)
Shunt Receiver Select	2A (1)
Shunt Reporting Code	17 - 1E (5 - 6)
Soft Zone Operation Enable	2F (4)
Test Report Code	2B (1 - 2)
Test Report Interval	2B (4)
Test Report Receiver Select	2B (3)
Unit Status Code	2A (3)
Unit Status Receiver	2A (4)
User Arming Type	01 - 08 (1)
User Combinations	01 - 08 (2 - 6)

PROGRAMMING THE PANEL

All panel wiring for the SYSTEM 238 should be completed prior to applying power. **You can only access the programming mode when the control panel is disarmed.**

You can program the SYSTEM 238 from the LED or Alpha keypad, or remotely using the COMMANDER II software. Remote programming information can be found in the COMMANDER II/MONITOR II Operating Manual. This manual contains a brief description of each programming option beginning on page 8.

To Start Keypad Programming

Key in the [Installer Combination] [*] [0] [#]. The default Installer Combination is **0 1 2 3 4 5**. The programming mode is indicated by the Program LED being lit on the LED keypad or **CMD DATA** being displayed across the top row of the LCD display for the Alpha keypad.

Programming with the LED Keypad

Programming with an LED keypad is a one-step process. Key in the two-digit address (Command Location), followed immediately by the desired programming values (program data), then press the [#] key to store the data. The LED keypad does not display any programmed values. If you are not sure that the correct programming values have been entered, program the Command Location again.

NOTE: To program Command Location A0 with an LED keypad, remember to enter the Command Location, followed by the program data, then press the [#] key.

Warning: If you enter a Command Location and then press the [#] key without entering any program data, the keypad will beep 5 times, indicating an error. To correct this problem, simply re-enter the Command Location and Data, then press the [#] key.

Programming with the Alpha Keypad

Entering program data with an Alpha keypad is a two-step process. First, key in the two-digit address (Command Location) to be programmed and press the [#] key. The Alpha keypad displays the Command Location and the data previously stored. Enter the new data you wish to store and press the [#] key to write the data. You can also scroll through the Command Locations in numerical order by alternately pressing and releasing the [#] key.

NOTE: Command Location A0 must be addressed directly. When programming this Command Location with an Alpha keypad, the previously stored data is not displayed. To program this location, enter the Command Location followed by the [#] key. Then enter the data to be stored and again press the [#] key.

Programming Hexadecimal Numbers

The Alpha keypad may be used to program the control panel. The cursor is moved using the "E" and "P" keys, as indicated in the figure below. The "F" key enters a blank space and moves the cursor one position to the right.

Data is programmed into the panel using the hexadecimal number system, which consists of the digits 0 - 9 and the letters A - F. The digits 0 - 9 are entered directly from the keypad. The chart below shows how to enter the hexadecimal digits A through F.

PROGRAMMING CONVERSIONS	
Hexadecimal Value	Key Strokes
A	*0
B	*1
C	*2
D	*3
E	*4
F	*5

PROGRAMMING the ALPHA KEYPAD

Ensure the Alpha keypad is wired to the SYSTEM 238 and power is applied to the control panel. **You can only access the programming mode when the control panel is disarmed.**

NOTE: Programming the Keypad is not the same as Keypad Programming.

The last two Command Locations are CL 37 and CL A0. Pressing the [#] key at these locations will advance you to CL 38 or CL A1, respectively. Locations CL 38 and CL A1 are not used in the SYSTEM 238. If you accidentally enter either of these locations, press [*] [#] to exit programming, or enter the Command Location number, followed by the [#] key, for the location you wish to program.

The Alpha Keypad

You can program the Alpha keypads for special messages, each of the 8 zone labels, and the keypad address. **Zone Labels** display during the walk-test and when the [#] key is pressed during alarm memory or faults. The programmable **Service Message** is displayed during AC failure, fuse failure, communication failure, or low battery. The **Dealer Message** displays when the system is disarmed. The keypad address is initially displayed only during system start up (see page 5, Keypad Addressing).

These messages can be programmed directly from the Alpha keypad or remotely using the Commander II/Monitor II software package. For more detailed information about remote programming, refer to the Commander II/Monitor II Operating Manual.

Keypad Message Programming

The Alpha keypad programming template is used to allow the installer to program messages and zone descriptions into the Alpha keypads. The template shown below should be used when programming the keypad.

To activate the keypad programming mode, enter the [Installer's Code] [*] [0] [1] [#]. Information may be entered into the keypad in the form of letters (upper and lower case), numbers (0 - 9), and 22 special symbols. All characters are displayed in the order listed above, i.e. upper and lower case letters, numbers, and special symbols. The [Space] character precedes the letter A.

To enter a Message or Label, use the [2] key to scroll through the characters until you reach the desired character. If you scroll past the desired character, the [8] key may be used to scroll backwards.

When the desired character is displayed, press the [6] key to move the cursor to the next character position. The [4] key moves the cursor to the left. When all characters have been entered, press the [#] key to write the message and move to the next message position. Use the [0] key to move backward through the messages.

The Scrolling order of the Alpha Plus messages is:

- SERVICE MESSAGE
- DEALER MESSAGE
- SOFT ZONE IDENTIFIER (C)
- HARDWIRED LOOP IDENTIFIERS
- KEYPAD ADDRESS

Both the Alpha and the Alpha Plus use the same procedure to program messages.

ALPHA II Programming Template

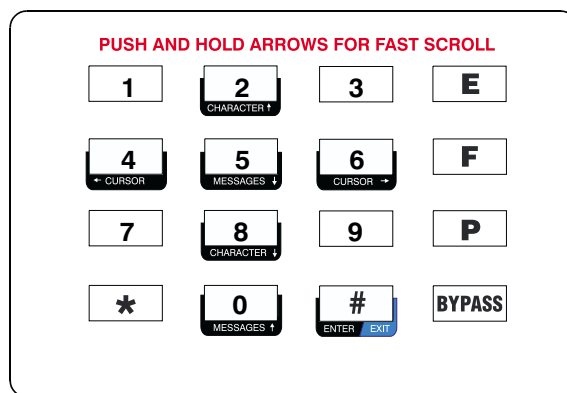

ALPHA PLUS Programming Template

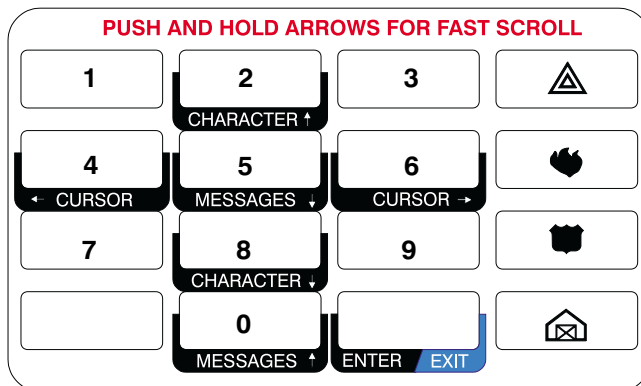

NOTE: If you do not press any key for 5 minutes, the keypad will automatically exit the programming mode.

To Exit Keypad Programming

When you have finished programming, press [*] [#]. **The keypad will also exit the programming mode if you do not press any key within a five minute period.**

Command Locations 00 - 08

Command Location 00: Installer Combination

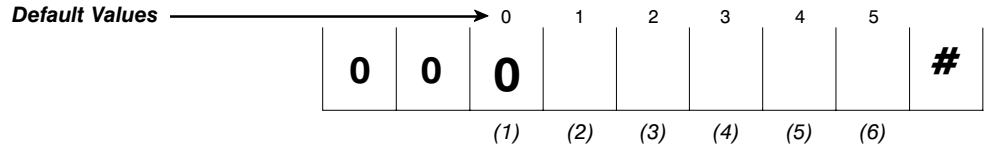

Digit Position (1): First Digit of Installer Combination
 Hard-coded to "0". Installer's combination will always start with 0.

Digit Positions (2) - (6): Remaining Digits in Combination
 Combination must have 5 digits in addition to Position (1).
 Valid entries are 0 - 9.

Command Location 01 - 08: User Arming Type and Combination

- 01 = User #1 (Master)
- 02 = User #2
- 03 = User #3
- 04 = User #4
- 05 = User #5
- 06 = User #6
- 07 = User #7
- 08 = User #8 (Guest)

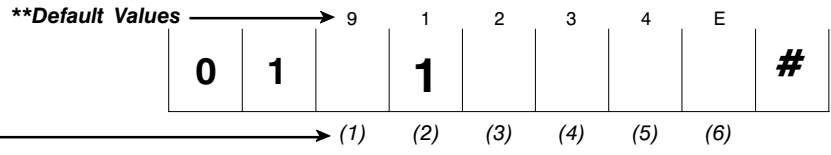

Digit Position (1): Arming Type

- 1 = Arm Only, No Closing (C) Report, No Shunting
- 2 = Disarm Only, No Opening (O) Report, No Shunting
- 3 = Arm and Disarm, No O/C Reports, No Shunting
- 4 = Arm Only, with Closing Report, No Shunting
- 5 = Disarm Only, with Opening Report, No Shunting
- 6 = Arm and Disarm, with O/C Reports, No Shunting
- 7 = Arm Only, No Closing Report, Shunting Allowed
- 8 = Disarm Only, No Opening Report, Shunting Allowed
- 9 = Arm and Disarm, No O/C Reports, Shunting Allowed
- *0 = Arm Only, with Closing Report, Shunting Allowed
- *1 = Disarm Only, with Opening Report, Shunting Allowed
- *2 = Arm and Disarm, with O/C Reports, Shunting Allowed

****Default Values are different for each user. Refer to the SYSTEM 238 Programming Worksheet at the end of this manual for other user default values.**

Digit Position (2): First Digit of Arming Code
 Hard-coded to User's PIN. You cannot change this number.

Digit Positions (3) - (6): Remaining Digits in Combination
 Combination may have from 1 - 4 digits in addition to Position (2).
 Valid entries are 0 - 9.

NOTE: Some programming locations allow variable-length data and require an End-of-Number (EON) character. Program *4 ("E") after the last digit. Fill remaining unused Positions with "0". The EON character is not required if the last digit is in Position (6).

PROGRAMMING CONVERSIONS	
Hexadecimal Value	Key Strokes
A	*0
B	*1
C	*2
D	*3
E	*4
F	*5

Command Location 09: Arming/Combination Options

Default Values →

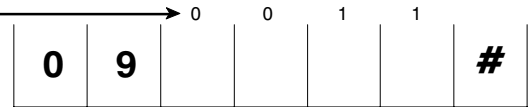

Digit Position (1): Guest Combination Time

- | | | |
|-------------------------|------------|---------------|
| 0 = Guest Time Disabled | 5 = 5 days | * 0 = 10 days |
| 1 = 1 day | 6 = 6 days | * 1 = 11 days |
| 2 = 2 days | 7 = 7 days | * 2 = 12 days |
| 3 = 3 days | 8 = 8 days | * 3 = 13 days |
| 4 = 4 days | 9 = 9 days | * 4 = 14 days |
| | | * 5 = 15 days |

Digit Position (2): Combination Command

- 0 = No
 1 = Yes; requires combination for Bypass, Group Bypass, Instant Arm, keypad activated RPS, and Test (central station and bell)

Digit Position (3): Default Installer Combination

- 0 = No; this enables the Pirate-Guard™ feature for added security
 1 = Yes; combination changes back to factory value on power loss

Digit Position (4): Faulted Arming Type

- 1 = Goof-Proof: zones must be normal or shunted to arm
 2 = Force Arm: faulted zones will be shunted at end of Exit Delay
 3 = Chirp Alert: faulted delay zones will chirp bell during Exit Delay

Command Location 0A: Communications Formats

Default Values →

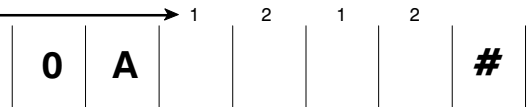

Digit Position (1): Receiver #1 Receiver Format

- | | | |
|-----------------------|-----------------------|-------------------|
| 1 = Fast "A", 2300 Hz | 3 = SumCheck, 1400 Hz | 5 = CFSK III |
| 2 = Slow "B", 1400 Hz | 4 = SumCheck, 2300 Hz | 6 = DTMF, 1400 Hz |

Digit Position (2): Receiver #1 Message Format

- | | | | |
|------------------|----------------------------------|---------------------|-------------------------|
| 1 = 3/1 single | 3 = 4/2 (2-digit reporting code) | 5 = CFSK III | 7 = 4+2 SumCheck (DTMF) |
| 2 = 3/1 extended | 4 = 4/1 | 6 = 4/9 Ademco DTMF | |

Digit Position (3): Receiver #2 Receiver Format

- | | | |
|-----------------------|-----------------------|-------------------|
| 1 = Fast "A", 2300 Hz | 3 = SumCheck, 1400 Hz | 5 = CFSK III |
| 2 = Slow "B", 1400 Hz | 4 = SumCheck, 2300 Hz | 6 = DTMF, 1400 Hz |

Digit Position (4): Receiver #2 Message Format

- | | | | |
|------------------|----------------------------------|---------------------|-------------------------|
| 1 = 3/1 single | 3 = 4/2 (2-digit reporting code) | 5 = CFSK III | 7 = 4+2 SumCheck (DTMF) |
| 2 = 3/1 extended | 4 = 4/1 | 6 = 4/9 Ademco DTMF | |

Valid combinations of Receiver Format and Message Format are listed below.

Message Format	Receiver Format(s)
3/1 Single or 3/1 Extended	All formats, except CFSK III and DTMF, 1400 Hz
4/1 or 4/2 (2-digit reporting)	Fast "A", 2300 Hz and Slow "B", 1400 Hz only
CFSK III	CFSK III only
SumCheck (DTMF)	DTMF, 1400 Hz only

Command Locations 0B and 0C

Command Location 0B: Communications Control

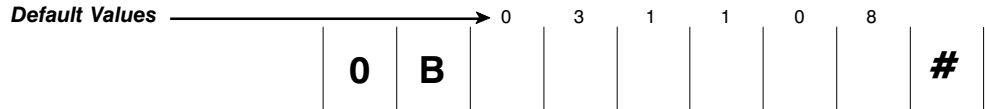

Digit Position (1): Delay Before Dial Time

- 0 = 0 secs 4 = 40 secs 8 = 80 secs *2 = 120 secs
- 1 = 10 secs 5 = 50 secs 9 = 90 secs *3 = 130 secs
- 2 = 20 secs 6 = 60 secs *0 = 100 secs *4 = 140 secs
- 3 = 30 secs 7 = 70 secs *1 = 110 secs *5 = 150 secs

Digit Position (2): Dial Type

- 1 = DTMF - Touch Tone (10/sec) 2 = DTMF (5/sec) 3 = Pulse (10/sec)

Digit Position (3): Enable Keypad Activated RPS

- 0 = No
- 1 = Yes; allows remote programming to start from on-site keypad command

Digit Position (4): RPS Enable

- 0 = No
- 1 = Yes; allows remote programming to start from off-premise location

Digit Position (5): Phone Ring Type

- 0 = Single ring; uniformly timed rings with long pauses between rings
- 1 = Double ring; rings twice quickly followed by a long pause then rings twice again

Digit Position (6): Dialing Attempts

- 1 = 1 try 5 = 5 tries 9 = 9 tries *3 = 13 tries
- 2 = 2 tries 6 = 6 tries 0 = 10 tries *4 = 14 tries
- 3 = 3 tries 7 = 7 tries *1 = 11 tries *5 = 15 tries
- 4 = 4 tries 8 = 8 tries *2 = 12 tries

Command Location 0C: Account Number 1

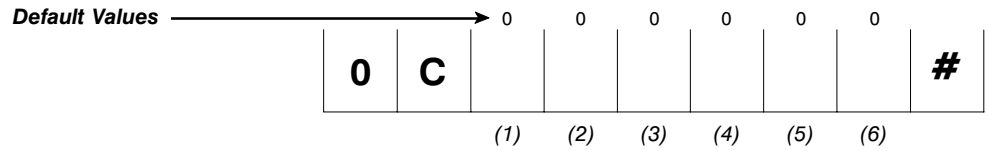

Digit Positions (1) - (6): Account Number

Valid entries are 0 - F.
 The Account Number is right justified. The last digit must be in Position (6).
 The SYSTEM 238 will read the account number using:
 Digit Positions (4) - (6) in 3-digit accounts
 Digit Positions (3) - (6) in 4-digit accounts
 Digit Positions (1) - (6) in 6-digit accounts
 Fill all unused Digit Positions with 0's.

PROGRAMMING CONVERSIONS	
Hexadecimal Value	Key Strokes
A	*0
B	*1
C	*2
D	*3
E	*4
F	*5

Command Locations 0D - 0F: Receiver #1 Phone Number

Order in which the numbers will be dialed

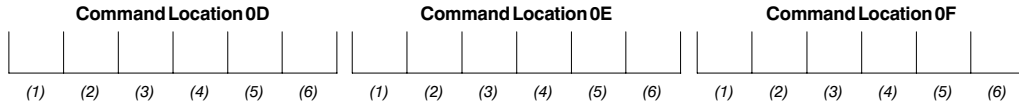

Command Location 0D: Receiver #1 Phone Number (digits 1 - 6)

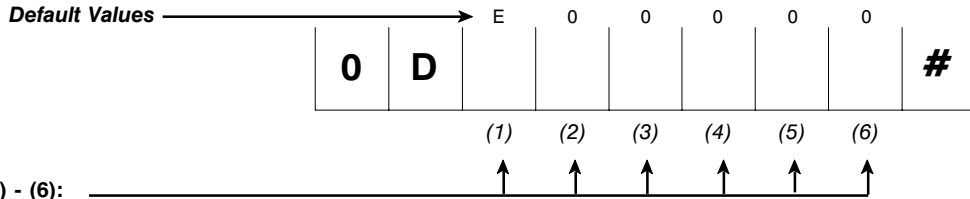

Digit Positions (1) - (6):

- 0-9 = dialing digits
- *0 = dial tone detect
- *2 = * (DTMF dialing only, not used in pulse dialing)
- *3 = # (DTMF dialing only, not used in pulse dialing)
- *4 = end of number
- *5 = 5 second delay

Digit (1) is dialed first.
 You must place a *4 (EON) after the last digit to be dialed. Fill in remaining positions with "0". The zeroes will not be dialed.

Command Location 0E: Receiver #1 Phone Number (digits 7 - 12)

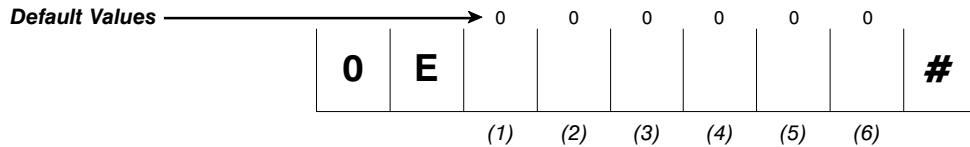

Command Location 0F: Receiver #1 Phone Number (digits 13 - 18)

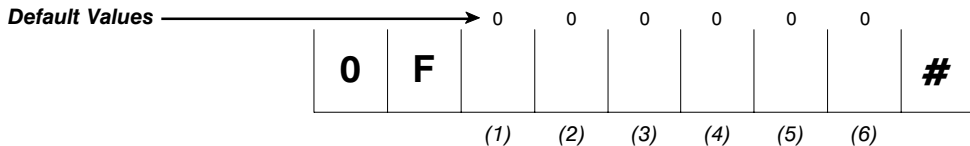

Command Location 10: Account Number 2

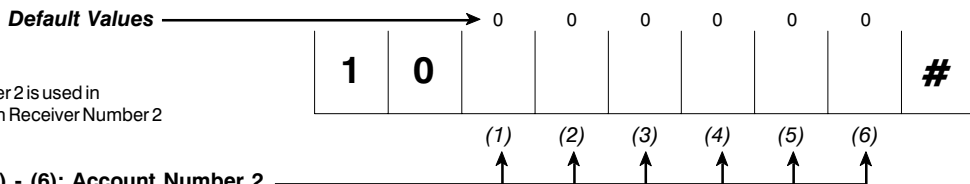

Account Number 2 is used in conjunction with Receiver Number 2

Digit Positions (1) - (6): Account Number 2

Valid entries are 0 - F.
 Entries 0 and A both transmit 10 pulses. The Account Number is right justified.
 The last digit must be in Position (6). The SYSTEM 238 will ignore unused Digit Positions:
 Digit Positions (1) - (3) in 3-digit accounts
 Digit Positions (1) & (2) in 4-digit accounts
 Fill left hand unused portions with any digit values. They will not be used by the system.

PROGRAMMING CONVERSIONS	
Hexadecimal Value	Key Strokes
A	* 0
B	* 1
C	* 2
D	* 3
E	* 4
F	* 5

Command Locations 11 - 13

Command Locations 11 - 13: Receiver #2 Phone Number

Order in which the numbers will be dialed

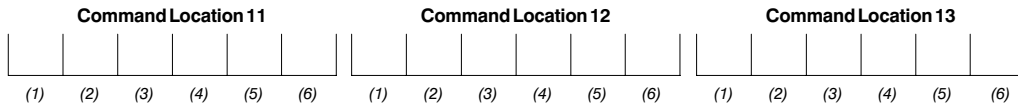

Command Location 11: Receiver #2 Phone Number (digits 1 - 6)

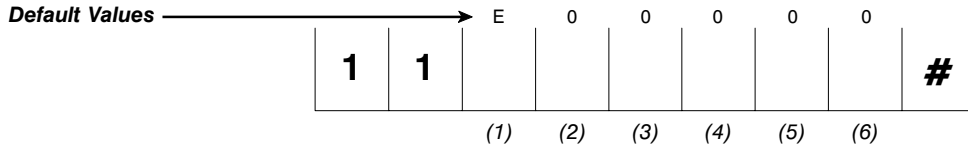

Digit Positions (1) - (6):

- 0 - 9 = dialing digits
- * 0 = dial tone detect
- * 2 = * (DTMF dialing only, not used in pulse dialing)
- * 3 = # (DTMF dialing only, not used in pulse dialing)
- * 4 = end of number
- * 5 = 5 second delay

Digit (1) is dialed first.
You must place a *4 (EON) after the last digit to be dialed. Fill in remaining positions with "0". The zeroes will not be dialed.

Command Location 12: Receiver #2 Phone Number (digits 7 - 12)

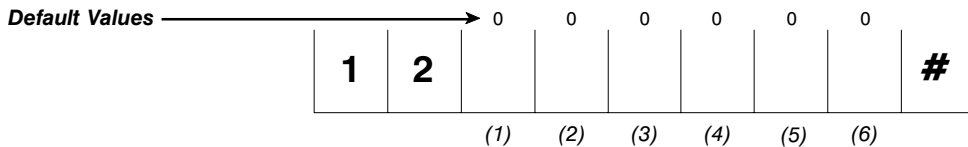

Command Location 13: Receiver #2 Phone Number (digits 13 - 18)

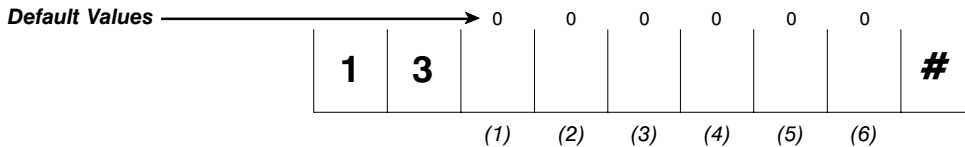

PROGRAMMING CONVERSIONS	
Hexadecimal Value	Key Strokes
A	* 0
B	* 1
C	* 2
D	* 3
E	* 4
F	* 5

Command Locations 14 - 16: RPS Phone Number

Order in which the numbers will be dialed

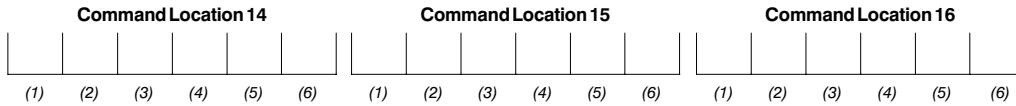

Command Location 14: RPS Phone Number (digits 1 - 6)

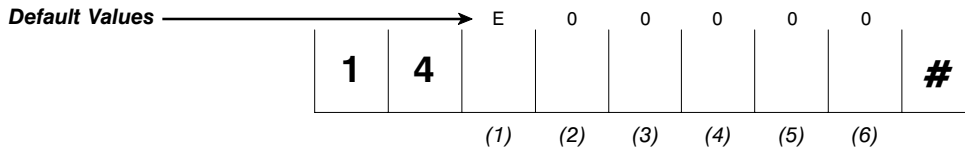

Digit Positions (1) - (6):

- 0 - 9 = dialing digits
- * 0 = dial tone detect
- * 2 = * (DTMF dialing only, not used in pulse dialing)
- * 3 = # (DTMF dialing only, not used in pulse dialing)
- * 4 = end of number
- * 5 = 5 second delay

Digit (1) is dialed first.
 You must place a *4 (EON) after the last digit to be dialed. Fill in remaining positions with "0". The zeroes will not be dialed.

Command Location 15: RPS Phone Number (digits 7 - 12)

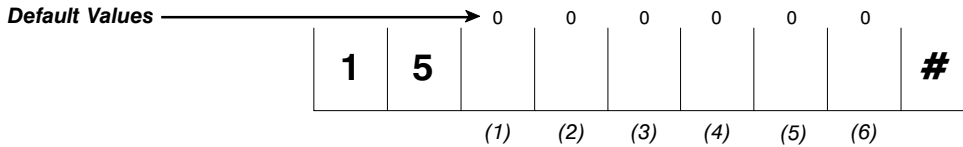

Command Location 16: RPS Phone Number (digits 13 - 18)

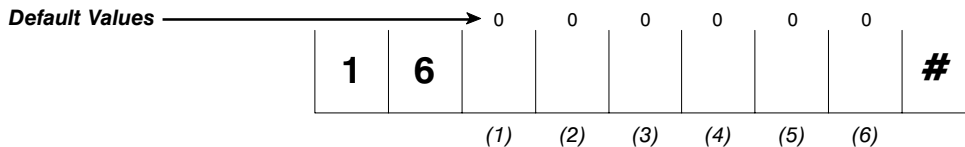

NOTE: In order to utilize the Remote Programming feature, CL 0B, Digit Positions (3) and (4) must also be programmed with YES.

PROGRAMMING CONVERSIONS	
Hexadecimal Value	Key Strokes
A	* 0
B	* 1
C	* 2
D	* 3
E	* 4
F	* 5

Command Locations 17 - 1E: Loop Reporting Codes

****Default Values**

- 17 = Loop 1
- 18 = Loop 2
- 19 = Loop 3
- 1A = Loop 4
- 1B = Loop 5
- 1C = Loop 6
- 1D = Loop 7
- 1E = Loop 8



Digit Positions (1) & (2): Alarm Reporting Code

Digit Positions (3) & (4): Restore Reporting Code

Digit Positions (5) & (6): Shunt Reporting Code

Only Position (1) is sent for 3/1 and 4/1 formats.
 Positions (1) and (2) are sent for 3/1 Extended, 4/2, and CFSK formats.
 Program 00 to disable Event Reporting for a loop.
 If using 3/1 or 4/1 format, fill unused positions with "0".

****Default Values are different for each loop. Refer to the SYSTEM 238 Programming Worksheet at the end of this manual.**

Command Locations 1F - 26: Loop Control

****Default Values**

- 1F = Loop 1
- 20 = Loop 2
- 21 = Loop 3
- 22 = Loop 4
- 23 = Loop 5
- 24 = Loop 6
- 25 = Loop 7
- 26 = Loop 8

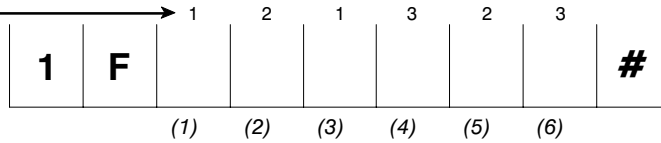

Digit Position (1): Alarm Receiver Select

- 0 = Receiver 1 with Receiver 2 as back-up
- 1 = Receiver 1 only
- 2 = Receiver 2 only
- 3 = Receiver 1 and Receiver 2 (Dual Reporting)

Digit Position (2): Loop Response Time

- 0 = 5 milliseconds
- 1 = 250 milliseconds
- 2 = 500 milliseconds
- 3 = 750 milliseconds

Digit Position (3): Loop Restore Type

- 0 = No Restoral Report sent
- 1 = Restoral sent when loop normal
- 2 = Restoral sent when loop normal and bell silences
- 3 = Restoral sent when loop normal and system disarmed

Digit Position (4): Loop Arming Type

- 1 = Interior: delayed during E/E delays
- 2 = Instant
- 3 = Delay
- 4 = Long Delay: delay two times as long
- 5 = Day/Instant: buzzer on day fault
- 6 = Day/Delay: buzzer on day fault
- 7 = Day/Instant with bell
- 8 = Day/Delay with bell
- 9 = 24 Hours: always armed

Digit Position (5): Loop Bell Type

- 1 = Temporal Code 3
- 2 = Steady
- 3 = Chirp
- 4 = Silent with no LED
- 5 = Silent with LED

Digit Position (6): Loop CircuitType

- 1 = Normally Open Circuit
- 2 = Normally Closed Circuit
- 3 = End Of Line (EOL)
- 4 = Supervised, bell latched
- 5 = Supervised, bell not latched

NOTE: A Loop programmed as type 4 or 5 will report any open as a Trouble condition, regardless of panel armed status.

PROGRAMMING CONVERSIONS

Hexadecimal Value	Key Strokes
A	* 0
B	* 1
C	* 2
D	* 3
E	* 4
F	* 5

Command Locations 27 - 29

Command Location 27: Soft Zone A (EMERGENCY)

Default Values →

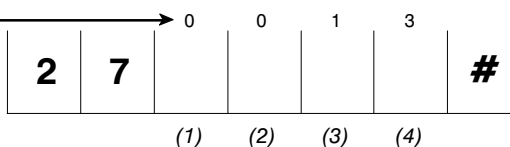

This Zone is identified by the "E" key on the Alpha II and LED keypads.

Digit Positions (1) and (2): Emergency Zone Code Report

Only Position (1) is sent for 3/1 and 4/1 formats.
Positions (1) and (2) are sent for 3/1 Extended, 4/2, and CFSK formats.
Program 00 to disable alarm reporting for Emergency zone.

Digit Position (3): Emergency Zone Receiver Select

0 = Receiver 1 with Receiver 2 as back-up 2 = Receiver 2 only
1 = Receiver 1 only 3 = Receiver 1 and Receiver 2 (Dual Reporting)

Digit Position (4): Emergency Zone Loop Bell Type

1 = Temporal Code3 2 = Steady 3 = Chirp 4 = Silent

NOTE: Command Location 2F Digit Position (4) must be programmed to YES to enable Soft Zones.

Command Location 28: Soft Zone B (Fire)

Default Values →

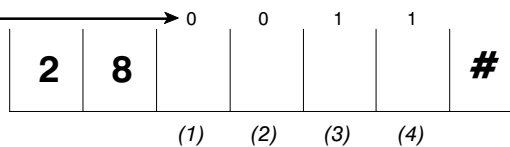

This Zone is identified by the "F" key on the Alpha II and LED keypads.

Digit Positions (1) and (2): Fire Zone Report Code

Digit Position (3): Fire Zone Receiver Select

Digit Position (4): Fire Zone Loop Bell Type

Refer to CL 27 for information about programming this zone.

Command Location 29: Soft Zone C (Police)

Default Values →

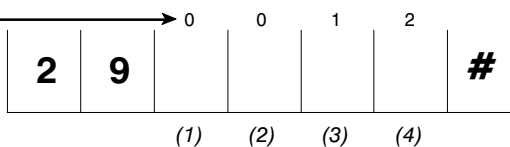

This Zone is identified by the "P" key on the Alpha II and LED keypads.

Digit Positions (1) and (2): Police Report Code

Digit Position (3): Police Zone Receiver Select

Digit Position (4): Police Loop Bell Type

Refer to CL 27 for information about programming this zone.

PROGRAMMING CONVERSIONS	
Hexadecimal Value	Key Strokes
A	* 0
B	* 1
C	* 2
D	* 3
E	* 4
F	* 5

Command Location 2A and 2B

Command Location 2A: Event Reporting

Default Values →



Digit Position (1): Shunt Receiver Select

- 0 = Receiver 1 with Receiver 2 as back-up
- 1 = Receiver 1 only
- 2 = Receiver 2 only
- 3 = Receiver 1 and Receiver 2 (Dual Reporting)

See also CL 17 - 1E
Digit Positions (5 & 6)

Digit Position (2): Restore Receiver Select

See Digit Position (1) for programming options.

See also CL 17 - 1E
Digit Positions (3 & 4)

Digit Position (3): Unit Status Report Code

Valid entries are 0 - F.
The panel will add a fixed extension digit when reporting in 3/1 Extended, 4/2, and CFSK formats.
Fixed codes are listed below.
Program a 0 to disable Unit Status Reporting.

Digit Position (4): Unit Status Receiver Select

See Digit Position (1) for programming options.

Digit Position (5): Cancel Report Code

Valid entries are 0 - F.
The panel will add the User ID # as the second digit when reporting in 3/1 Extended, 4/2, and CFSK formats.
Program a 0 to disable Cancel Reports.

Digit Position (6): Cancel Report Receiver Select

See Digit Position (1) for programming options.

UNIT STATUS FIXED EXTENSION CODES	
1 = Low battery	7 = AC restore
2 = AC fail	8 = Bell fuse restore
3 = Bell fuse fail	9 = Loop trouble restore
4 = Loop trouble	A = not used
5 = Failed to communicate	B = Watchdog reset
6 = Battery restore	C = Completed programming

PROGRAMMING CONVERSIONS	
Hexadecimal Value	Key Strokes
A	*0
B	*1
C	*2
D	*3
E	*4
F	*5

Command Location 2B: Test Report

Default Values →



Digit Positions (1) and (2): Test Report Code

Valid entries are 0 - F.
Only Position (1) is sent for 3/1 and 4/1 formats.
Positions (1) and (2) are sent for 3/1 Extended, 4/2, and CFSK formats.
Program 00 to disable Test Reports.

Digit Positions (3): Test Report Receiver Select

- 0 = Receiver 1 with Receiver 2 as back-up
- 1 = Receiver 1 only
- 2 = Receiver 2 only
- 3 = Receiver 1 and Receiver 2 (Dual Reporting)

Digit Positions (4): Test Report Interval

- | | | | | |
|-------------|--------------|-------------|-----------------------|------------------------|
| 1 = 1 hour | 4 = 12 hours | 7 = 14 days | *0 = 1 hour if armed | *3 = 12 hours if armed |
| 2 = 2 hours | 5 = 24 hours | 8 = 21 days | *1 = 2 hours if armed | *4 = 24 hours if armed |
| 3 = 4 hours | 6 = 7 days | 9 = 30 days | *2 = 4 hours if armed | |

NOTE: CL A0 must be programmed to correctly set time of test.

Command Location 2C: Opening and Closing Report Codes



Digit Position (1): Opening Report Code

Valid entries are 0 - F.

The User ID # is transmitted after the opening code for 3/1 Extended, 4/2, and CFSK formats.

Program 0 to disable Opening Reports.

Digit Position (2): Opening Report Receiver Select

0 = Receiver 1 with Receiver 2 as back-up

1 = Receiver 1 only

2 = Receiver 2 only

3 = Receiver 1 and Receiver 2 (Dual Reporting)

Digit Position (3): Closing Report Code

Valid entries are 0 - F.

The User ID # is transmitted after the opening code for 3/1 Extended, 4/2, and CFSK formats.

Program 0 to disable Closing Reports.

Digit Position (4): Closing Report Receiver Select

0 = Receiver 1 with Receiver 2 as back-up

1 = Receiver 1 only

2 = Receiver 2 only

3 = Receiver 1 and Receiver 2 (Dual Reporting)

Command Location 2D: Duress Report and Delays



Digit Position (1): Duress Report Code

Valid entries are 0 - F.

The User ID # will be reported as the second digit when reporting in the 3/1 Extended, 4/2, or CFSK formats.

Program 0 to disable Duress Reports.

Digit Position (2): Duress Receiver Select

0 = Receiver 1 with Receiver 2 as back-up

1 = Receiver 1 only

2 = Receiver 2 only

3 = Receiver 1 and Receiver 2 (Dual Reporting)

Digit Position (3): Entry Delay Time

1 = 10 secs

2 = 20 secs

3 = 30 secs

4 = 40 secs

5 = 50 secs

6 = 60 secs

7 = 70 secs

8 = 80 secs

9 = 90 secs

* 0 = 100 secs

* 1 = 110 secs

* 2 = 120 secs

* 3 = 130 secs

* 4 = 140 secs

* 5 = 150 secs

NOTE: To program delay times greater than 150 secs, see CL 1F - 26 Digit Position (4)

Digit Position (4): Exit Delay Time

1 = 10 secs

2 = 20 secs

3 = 30 secs

4 = 40 secs

5 = 50 secs

6 = 60 secs

7 = 70 secs

8 = 80 secs

9 = 90 secs

* 0 = 100 secs

* 1 = 110 secs

* 2 = 120 secs

* 3 = 130 secs

* 4 = 140 secs

* 5 = 150 secs

NOTE: To program delay times greater than 150 secs, see CL 1F - 26 Digit Position (4)

Digit Position (5): Audible Time

1 = 2 min

2 = 5 min

3 = 10 min

4 = 15 min

5 = 30 min

PROGRAMMING CONVERSIONS

Hexadecimal Value	Key Strokes
A	* 0
B	* 1
C	* 2
D	* 3
E	* 4
F	* 5

Command Location 2E: Audible/Visual Switches



Digit Position (1): Entry Pre-alarm Enable → (1)

0 = No
 1 = Yes: sounds keypad buzzers during entry delay

Digit Position (2): Exit Pre-alarm Enable → (2)

0 = No
 1 = Yes: sounds keypad buzzers during exit delay

Digit Position (3): Bell Reverse Operation → (3)

0 = No
 1 = Yes: supplies bell voltage in non-alarm state; Bell requires external power supply

Digit Position (4): Ring Back → (4)

0 = No
 1 = Yes: Automatic Bell test after arming (and Exit Delay has expired) for local or non-supervised accounts; follows closing report for supervised accounts; sounds bell for 2 seconds.

Digit Position (5): Disable Loop LEDs → (5)

0 = No
 1 = Yes: turns off keypad zone LEDs after 5 minutes

Command Location 2F: Unit Control



Digit Position (1): Local System Only → (1)

0 = No
 1 = Yes: disables all communications except RPS

Digit Position (2): Enable Daily Dynamic Battery Test → (2)

0 = No
 1 = Yes: tests battery under load every 24 hours

Digit Position (3): Enable Four Minute Power-Up Delay → (3)

0 = No
 1 = Yes: suppress alarms on power-up for 4 minutes

Digit Position (4): Enable Soft Zone Operation → (4)

0 = No
 1 = Yes: allows use of Emergency, Fire, and Police keys

Command Locations 30 - 37: Loop Switches

****Default Values** → 0 0 0 0

- 30 = Loop 1
- 31 = Loop 2
- 32 = Loop 3
- 33 = Loop 4
- 34 = Loop 5
- 35 = Loop 6
- 36 = Loop 7
- 37 = Loop 8



****Default Values are different for each loop. Refer to the SYSTEM 238 Programming Worksheet at the end of this manual for other default values.**

Digit Position (1): Enable Door Chime

- 0 = No
- 1 = Yes: keypads beep 2 seconds when faulted (disarmed condition)

Digit Position (2): Allow Shunting of This Loop

- 0 = No: makes it a priority zone (not shuntable)
- 1 = Yes: authorized users can bypass or force arm

Refer to CL.01 - 08 Digit Position (1) for Arming Types (Authorization Levels).

Digit Position (3): Allow Group Shunting for This Loop

- 0 = No
- 1 = Yes: include as part of group when performing Home Arming or Instant/Home Arming feature (See also pages 21 & 25)

Digit Position (4): Delay Before Dial

- 0 = No
- 1 = Yes: this loop will delay dialing on alarm for time programmed in 0B (1)

Command Location A0: Set Test Report Countdown Timer

This command will set the time when the first Test Report is transmitted to the central station. The panel will use this transmission time each time it's powered up or the CPU is reset (unless Command Location A0 is reprogrammed).

Previously stored data is not displayed during programming.



Digit Position (1): Set Countdown Timer → (1)

- | | | |
|--------------|--------------|----------------|
| 0 = 1/4 hour | 5 = 4 hours | * 0 = 14 hours |
| 1 = 1/2 hour | 6 = 6 hours | * 1 = 16 hours |
| 2 = 1 hour | 7 = 8 hours | * 2 = 18 hours |
| 3 = 2 hours | 8 = 10 hours | * 3 = 20 hours |
| 4 = 3 hours | 9 = 12 hours | * 4 = 22 hours |
| | | * 5 = 24 hours |

NOTE: Refer to CL.2B (4) for setting the time interval between Reports.

Example: The time is 1500 hours (3:00 pm). You want the first Test Report to transmit at 0100 hours (1:00 am). 3:00 pm + 10 hours = 1:00 am. Program the value "8" in Memory Location A0.

PROGRAMMING CONVERSIONS	
Hexadecimal Value	Key Strokes
A	* 0
B	* 1
C	* 2
D	* 3
E	* 4
F	* 5

KEYPAD LABEL DRAWER

Each keypad comes with a Label Drawer and quick reference operating label. Follow the diagram below to set up the Label Drawer

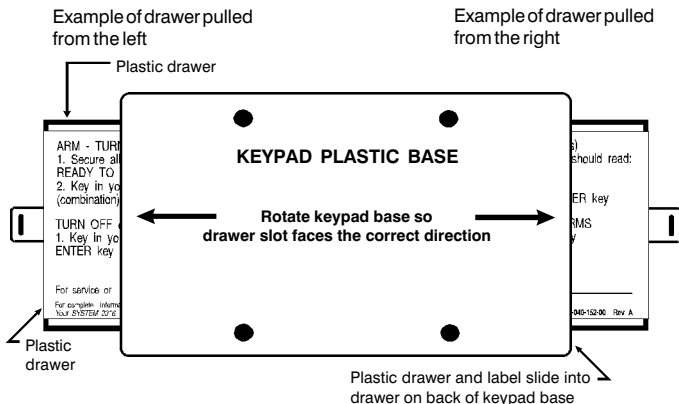

1. Fill in the zone descriptions inside the label.
2. Mark "Y" or "N" to indicate if zones can be bypassed or not.
3. Determine if the drawer will slide from the right or left.
4. Peel the cover off the drawer glue.
5. Align the edge of the label with the edge of the drawer. Center the label top to bottom.
6. Press the label onto the glue. Avoid trapping air bubbles under the label.
7. Slide the drawer/label into the slot on the back of the keypadbase.

TESTING

Once the installation is complete, connect AC and DC power. Complete programming, if required. **Test all panel operations.**

TO THE INSTALLER

Regular maintenance and inspection (at least monthly) by the installer and frequent testing by the user are vital to the continuous and satisfying operation of any alarm system. The installer should assume the responsibility for developing and offering a regular maintenance program to the user, as well as acquainting the user with the proper operation and limitations of the alarm system and its component parts. **Recommendations must include a specific program of regular testing (at least weekly) to insure that the system is operating properly at all times.**

TELEPHONE LINE PROBLEMS

In the event of telephone line problems, disconnect the SYSTEM 238 by removing the modular connector plug from the Telco interface jack. **Do not disconnect the connection inside the SYSTEM 238 cabinet.** Doing so will prevent the premise phones from operating. If your phone works correctly after the control panel has been disconnected from the phone line, the control panel has a problem and should be returned for repair.

If the phone does not work after you have disconnected the control panel from the phone line, notify the telephone company and request prompt repair. **The user may not under any circumstance (in or out of warranty) attempt any service or repairs on the SYSTEM 238.** The control panel must be returned to C&K SYSTEMS or an authorized service agency for repairs.

Watchdog Indicator



WATCH
DOG

DS1 The SYSTEM 238 is protected by an advanced circuit, called a Watch Dog circuit, that constantly monitors the microprocessor.

As long as the panel has power and is operating normally, the Watch Dog LED (DS1) on the circuit board will flash. If the Watchdog circuit detects a failure, it will attempt to reset the panel.

If the panel does not operate properly, and the Watchdog LED no longer flashes, call the **C&K Technical Support Hotline at 1-800-227-8065** in the U.S. or your local C&K Representative.

FCC NOTICE

WARNING: This device is intended to be installed by a professional alarm installer.

The user shall be cautioned that changes or modifications not expressly approved by C&K SYSTEMS could void the user's authority to operate the equipment.

This equipment complies with FCC Rules, Part 68.

On the outside of this equipment is a label that contains, among other information, the FCC Registration Number and Ringer Equivalence Number (REN) for this equipment. If requested, provide this information to your telephone company.

The REN is useful to determine the quantity of devices you may connect to your telephone line and still have all of those devices ring when your number is called. In most, but not all areas, the sum of the REN's devices should not exceed five (5.0). To be certain of the number of devices you may connect to your line, as determined by the REN, you should call your local telephone company to determine the maximum REN for your calling area.

Should you experience trouble with the telephone lines, disconnect the equipment from the line to determine the source of the trouble. If it is determined that the equipment is malfunctioning, discontinue its use until the malfunction has been corrected. Any repairs or alterations made by the user to this equipment, or equipment malfunctions, may give the telephone company cause to request the user to disconnect the equipment. Repairs to this equipment should be made by an authorized agent of C&K Systems, Inc. Contact your local alarm installation company for service.

Should this equipment cause harm to the telephone network, the telephone company may temporarily discontinue your service. If possible, they will provide you with advance notice. Otherwise they will notify you as soon as possible. The telephone company will also advise you of changes in its facilities, equipment, operations or procedures which could affect the operation of your equipment, allowing you the opportunity to maintain uninterrupted service. You will also be advised of your right to file a complaint with the FCC.

This equipment must not be used on party lines or coin operated phone lines.

FCC Part 15 Notice

This equipment has been tested and found to comply with the limits for Class B digital devices, pursuant to Part 15 of the FCC Rules. These limits are designed to provide reasonable protection against harmful interference in a residential installation.

This equipment generates, uses, and can radiate radio frequency energy, and if not installed and used in accordance with the instructions, may cause harmful interference to radio communications. However, there is no guarantee that interference will not occur in a particular installation.

If this equipment does cause harmful interference to radio or television reception, which can be determined by turning the equipment off and on, the user is encouraged to try to correct the interference by one or more of the following measures:

- Reorient the radio/television antenna;
- Connect the AC transformer to a different outlet so that the equipment and radio/television are on different branch circuits;
- Relocate the equipment with respect to the radio/television;
- Consult the dealer or an experienced radio/television technician for help.

FCC Registration Number: C2DCHN-18741-ALE
Ringer Equivalence: 0.3B

CANADIAN EMISSION REQUIREMENTS

This Class B digital apparatus meets all requirements of the Canadian Interference-Causing Equipment Regulations.

Cet appareil numérique de la classe B respecte toute les exigences du Règlement sur le matériel brouilleur du Canada.

Keypad Operation Command Summary

The majority of the keypad commands apply equally to the LED and Alpha II keypads. Some keypad commands, however, apply to the LCD keypad only.

The following Keypad Commands apply to both the LED and Alpha II keypads:

Function	Comments	Keystroke Sequence
Arm/Disarm	Delays active	[Combination] [#]
Bypass Zone (n)	[n] is zone # 1 - 8; Combo may be required	[Combination] [Bypass] [n] [#]
Chime On/Off	Combo may be required	[Combination] [*] [5] [#]
Change Combo (via Master Code)	Must be done by User #1	[Master Combo] [*] [0] [#] [New Combo] [#] [New Combo] [#]
Clear Alarm Memory		[*] [1] [#]
Exit Programming		[*] [#]
Fire Alarm	Keypad activated	[F] (Hold for 3 seconds)
Group Bypass and Arm	Arms system and all zones programmed for group bypass, CL 30 - 3F, Digit Position (3), are shunted simultaneously; Combo may be required. (Also called Home Arming)	[Combination] [*] [4] [#]
Group Bypass and Instant Arm	Same as Group Bypass (above) except system is Instant Armed (Exit Delay operates normally, upon expiration of Exit Delay, all delayed zones are converted to Instant - No Entry Delay. Combo may be required. (Also called Instant/Home Arming)	[Combination] [*] [4] [7] [#] or [Combination] [*] [7] [4] [#]
Instant Arm	Arms system and delayed zones are converted to Instant (Exit Delay active, No Entry Delay); Combo may be required	[Combination] [*] [7] [#]
Keypad Activated RPS	If enabled, CL 0B(3); Combo may be required	[Combination] [*] [0] [2] [#]
Medical Alarm	Keypad activated	[E] (Hold for 3 seconds)
Police/Panic Alarm	Keypad activated	[P] (Hold for 3 seconds)
Reset Aux Power	If resettable devices are connected to Terminals 5 and 6 (also resets devices connected to Loop 8 (e.g. 2-wire smoke detectors)	[*] [6] [2] [#]
Reset Panel		[Master Combination] [*] [6] [8] [#]
Test - Battery	Use after correcting Low Battery problem	[*] [6] [4] [#]
Test - Bells	Combo may be required	[Combination] [*] [6] [3] [#]
Test - Central Station	Combo may be required	[Combination] [*] [6] [1] [#]
Test - Local Walk Test		[*] [6] [0] [#]

NOTE: For additional information about Combination Command requirements, see page 24 and CL 09 (2).

The following Keypad Commands apply to the Alpha II keypad only:

Function	Comments	Keystroke Sequence
Error Tones Toggle On/Off		[*] [5] [4] [#]
Audible Feedback Toggle		[*] [5] [1] [#]
Backlight Toggle On/Off		[*] [8] [#]
Display Keypad Model & Revision Number		[*] [9] [#]
Chime Toggle		[*] [5] [3] [#]
Pre-warn Toggle On/Off		[*] [5] [2] [#]

The following Keypad Commands are Installer Only Commands:

Function	Comments	Keystroke Sequence
Alpha Keypad Programming	Start Programming the Keypad	[Installer Combination] [*] [0] [1] [#]
Alpha Keypad Test		[*] [6] [7] [#]
Kill/Revive Panel		[Installer Combination] [*] [6] [9] [#]
Panel Programming	Start Programming the Panel	[Installer Combination] [*] [0] [#]

Survey of Most Common Questions

The following is a summary of the questions most frequently asked of our Technical Support Department.

Question: *How do I program the panel with the LED keypad?*

Answer: To program with the LED keypad, enter the Command Location to be programmed, the Data to be programmed and the press the [#] key. (See also pages 6 - 7.)

For Example: To program User #2 with the ability to Arm only, No Reports and No Shunting; and a PIN of 2543, enter the following keystrokes:

CL	Arm Type	PIN (w/EON)	Write Data
[0][2]	[1]	[2][5][4][3][*][4]	[#]

NOTE: The first digit of the User Code MUST be the same as the User Number.

Question: *How do I access Alpha Keypad Programming to enter Zone Labels?*

Answer: To begin Alpha Keypad Programming (you cannot program the LED keypad), enter [Installer Combination] [*] [0] [1] [#]. Then scroll to the desired message location. (See also pages 7 - 8.)

Question: *How do I interpret a Trouble on the LED keypad? How do I clear a Trouble on the LED keypad?*

Answer: A number of conditions may cause the Trouble LED to light. See the chart below for additional information.

Trouble LED	Power LED	Zone LED's	Cause
Flash Slow	On	Off	Watchdog
On	On	Flash Slow	Zone Trouble
On	Off	Off	AC Failure
On	Flash Slow	Off	Low Battery
On	On	Off	System Trouble (Bell Fuse or Comm Fail.)

Question: *How do I enter hexadecimal numbers when using keypad programming?*

Answer: Hexadecimal values are entered through the use of the [*] key and one of the digits [0] - [5]. For additional help with entering hexadecimal numbers, refer to page 7. The hexadecimal conversion chart is also found at various locations throughout the programming section of the manual.

Question: *What is an "Interface error 1" and how do I correct the error?*

Answer: This error is caused by a problem with the Data line (Green wire) between the panel and the keypad. Check the connection to ensure that the wire is not pinched or loose. Also try disconnecting all keypads from the panel (one at a time), resetting the panel after each keypad is removed. Remember, to reset the panel press: [Master Combination] [*] [6] [8] [#].

Question: *How do I reset Alarm Memory?*

Answer: To Clear Alarm Memory, press [*] [1] [#].

Question: *How do I address an Alpha Keypad for the first time?*

Answer: If you have an Alpha keypad that has never been addressed, when power is initially applied, the display will read **KEYPAD ADDRESS?**. To enter the address, simply press a number between 0 and 7. Remove panel power for 3 seconds and then re-apply power to reset the system. For additional information about Keypad addressing, see page 5.

NOTE: If operating at or near the limit of AUX Power and Keypad Power, you may need to remove power for up to 30 seconds in order for the system to reset properly.

Question: *Why do my loops fail to respond after changing the programming?*

Answer: In order for the panel to recognize the programming changes for the loops, either the loops have to be tripped and restored or the panel must be reset ([Master Combination] [*] [6] [8] [#]).

Question: *How do I interpret the Unit Status Reports? Can the codes be changed?*

Answer: The Reporting Codes for the Unit Status Report is a two-digit code. The first digit is programmed into CL 2A Digit Position (3) and may be any value from 0 - F. The second digit is fixed by the firmware and cannot be changed. Please note that programming a 0 into 2A (3) will disable the report and no Unit Status information will be sent. Additional information about Unit Status Reporting Codes can be found on page 17 in the programming section.

Question: *How do I enter Receiver and RPS Phone Numbers? Why do I have to enter the E at the end of the number?*

Answer: The System 2316 is designed to handle phone numbers up to 18 digits long, but the firmware can only handle 6 digits per Command Location. This means that 3 Command Locations are required to store a phone number. With variations in number length and special characters which may need to be included, the software needs some method of determining the end of the number. The E (entered by pressing [*][4]) tells the software that it has reached the end of the phone number and to ignore any additional digits.

For Example: To program the panel for Receiver #1 with a phone number of 555-1212 and disable the call waiting feature using *70, enter the following sequence:

Command Location 0D						Command Location 0E						Command Location 0F					
C	7	0	5	5	5	1	2	1	2	E	0	0	0	0	0	0	0
(1)	(2)	(3)	(4)	(5)	(6)	(1)	(2)	(3)	(4)	(5)	(6)	(1)	(2)	(3)	(4)	(5)	(6)

NOTE: Entering [*] [2] in CL 0D (1) will display the value "C" and entering [*] [4] in CL 0E (5) will display the value "E".

Question: *How can I correct the problem of two Alpha keypads with the same address?*

Answer: When two keypads have been given the same address, a conflict occurs on the data bus since two keypads are trying to communicate at the same time. The only way to correct the problem is to disconnect both keypads and then re-address one of them, making sure that the address is not used by any other keypad. To re-address the keypad, enter Alpha Keypad Programming ([Installer Combination] [*] [0] [1] [#]) and scroll backward one step ([*] [BYPASS]). Then enter the new address. Don't forget to reset the panel ([Master Combination] [*] [6] [8] [#]) after changing the address, so the panel knows how to properly address the keypad. For additional information about keypad addressing, see page 5.

Question: *Why can't my panel communicate with the Central Station?*

Answer: There are several reasons for the panel not communicating. The first place to look is CL 2F (1). This is the Unit Control, if Digit Position (1) is programmed with a 1, all communication except RPS is disabled. If 2F (1) is programmed with a 0, check to ensure that all of the following parameters are properly set:

- Account Number 1 is programmed into CL 0C
- Receiver #1 Phone Number is correctly programmed into CL 0D - 0F
- Receiver Format and Message Format agree CL 0A
- Communication Control (CL 0B) is correctly programmed
- The RJ-31X jack is correctly wired (terminals 4 & 5 are not switched with 1 & 8)

Question: *How do I disarm my panel if I accidentally locked myself out by programming my user code as Arm Only?*

Answer: The only way to correct this problem is to access the panel through Remote Programming (RPS) or Direct Connect (also RPS) and disarm the panel. Then use the remote programming to re-program the panel. For additional information about RPS, see the Commander II/Monitor II Operating Manual.

Question: *Why doesn't my keypad respond? The Power LED is lit, but nothing happens.*

Answer: The panel may be in the KILL mode. On the LED keypad, only the Power LED will be lit. On the Alpha II keypad, the Power LED will be lit and the Service Message, if programmed, will be displayed. To restore the panel, press [Installer Combination] [*] [6] [9] [#].

Recommendations for Reducing False Alarms

The recommendations contained in this section are designed to assist you in reducing false alarms. The first column contains the Command Locations and Digit Positions in parentheses (). The second column is the recommended program option followed by a brief explanation.

<u>Program Option</u>	<u>CL</u>	<u>Program Function</u>	<u>Comments</u>
Arming/Combination Options	09 (2)	Combination Command	This feature is enabled to prevent unauthorized users from activating certain keypad functions. When activated, this command will require a valid User Combination to perform such functions as Bypassing a Zone, Group Bypassing, Keypad Activated RPS, Central Station and Bell Testing, and Instant Arming. For additional assistance with commands requiring User Combinations, see page 21 (Command Summary).
Arming/Combination Options	09 (4)	Chirp Alert	This option minimizes the possibility of creating an error when exiting. The system is armed in the normal manner and the user exits through the delayed exit door. If the door does not close properly (returning the loop to the normal state), the system will transition from the Exit Delay to the Entrance Delay upon the completion of the Exit Delay time the Bell will chirp , alerting the user to the error in arming the system.
Loop Control	1F - 26 (2)	Loop Response Time	This option determines the response time of the loop itself. It acts as a buffer on the loop to minimize the possibility of fast acting sensors, such as swingers on window foil, producing false alarms.
Loop Control	1F - 26 (3)	Loop Restore Type	This option is used in conjunction with CL 17 - 1E Digit Positions (3 & 4), Restore Reporting Code, and CL 2A (2), Restore Receiver Select. The panel can be programmed to send a Restoral Report only when the loop is normal and the system is disarmed. With this arrangement, any loop which is triggered multiple times while armed will only send one alarm report until the system is disarmed. This prevents the system from tying up the central station receivers and the phone line with continuous alarm and restoral reports.
Loop Control	1F - 26 (4)	Loop Arming Type	There may be occassion where it is desirable to program all doors and interior points as delayed. Or you may need to program interior zones to be delayed only during the Entry/Exit Delay Time. This Command Location allows a variety of Arming Types to help minimize false alarms.
Event Reporting	2A (5 & 6)	Cancel Report Code/Cancel ReportReceiver Select	This feature should always be enabled on reporting systems, especially if the system does not send Opening and Closing Reports. A Cancel Report is sent to the monitoring station in the event that an Authorized User clears the alarm while the bell is still active. The Cancel Report Code (Digit Position 5) is actually a two-digit code with the first digit being programmed by the installer and the second digit being the User ID # when the report is sent. Digit Position (6) determines which receiver gets the Cancel Report.

<u>Program Option</u>	<u>CL</u>	<u>Program Function</u>	<u>Comments</u>
Audible/Visual Switches	2E (1 & 2)	Entry/Exit Pre-Alarm	If Digit Position (1) is programmed for Entry Pre-Alarm, the keypad will beep for the amount of time programmed for the Entry Delay Time (CL 2D (3)). If Digit Position (2) is programmed for Exit Pre-Alarm, the keypad will beep for the time programmed into CL 2D (4), Exit Delay Time. The speed at which the keypad beeps will increase during the last 10 seconds of the Delay time. Alpha II keypads will display a bar graph in addition to the audible tone.
Unit Control	2F (3)	Enable 4-minute Power-Up Delay	Suppresses all trouble and alarm reports for a period of four minutes after power is initially applied to the panel. This allows the sensors, such as PIR's time to stabilize when initializing or prevents powered devices, such as smoke detectors, from sending alarms when first starting panel with a dead battery or no battery connected.
Loop Switches	30 - 37 (3)	Allow Group Shunting	This allows multiple loops to be shunted simultaneously with a single keypad command. This is typically done on all interior loops in a system.
Loop Switches	30 - 37 (4)	Delay Before Dial	This option programs the loops to have a delay after they are triggered to allow the User time to shut down the system in the event of an accidental triggering of the zone. The amount of time is determined by the value programmed into CL 0B Digit Position (1). The time delay may be between 10 and 150 seconds, in 10 second intervals.

THE LIMITATIONS OF YOUR ALARM SYSTEM

While the SYSTEM 238 is an advanced design security system, it does not offer guaranteed protection against burglary, fire, or other losses. Any alarm system, whether commercial or residential, is subject to compromise or failure-to-warn for a variety of reasons. These include:

- Intruders may gain access through unprotected openings or have the technical sophistication to bypass an alarm sensor or disconnect an alarm warning device.
 - Intrusion detectors, smoke detectors, and many sensing devices will not operate without power. Devices powered by AC will not work if their AC power supply is off for any reason and their back-up batteries are missing, dead, or improperly installed.
 - Alarm warning devices such as sirens, bells, and horns may not alert people or wake up sleepers if they are located on the other side of closed or partly closed doors. If warning devices are on a different level of the residence from the bedrooms, they are less likely to waken or alert people inside the bedrooms.
 - Telephone lines needed to transmit alarm signals from a premise to a central monitoring station may be out of service or temporarily out of service. Telephone lines are subject to compromise by sophisticated methods of attack.
- Smoke detectors used in conjunction with the alarm system may not sense fires that start where smoke cannot reach the detectors, such as chimneys, walls, or roofs, or on the other side of closed doors. Smoke detectors also may not sense a fire on another level of the residence or building. A second floor detector, for example, may not sense a first floor or basement fire. Finally, smoke detectors have sensing limitations. No smoke detector can sense every kind of fire every time. In general, detectors may not always warn you about fires caused by carelessness and safety hazards, like smoking in bed, violent explosions, escaping gas, improper storage of flammable materials, overloaded electrical circuits, children playing with matches, arson, etc.
 - The most common cause of an alarm system not functioning properly when an intrusion or fire occurs is inadequate maintenance. **Your** alarm system should be tested weekly to make sure all sensors are **operating properly**. **The SYSTEM 238 panel and keypads should also be tested.**
 - Installing an alarm system may make you eligible for lower insurance rates, but an alarm system is not a substitute for insurance. Homeowners, property owners, and renters should continue to insure their lives and property.

Note: The contents of this manual have been revised. For your convenience, dashed lines have been added to the margins of the document to show the locations of the changes.

SYSTEM 238 Programming Worksheet

Client: _____ **SYSTEM 238 Phone Number:** _____

Address: _____

Installer: _____ **Date:** _____ **Control Location:** _____

VOLTS

AC volts (term 1 and 2): _____

AUX POWER VOLTS

(term 5 and 6): _____

BATTERY VOLTS

Under load - AC off: _____

CURRENT

Keypads (term 6 and 8): _____

SWITCHED AUX + (term 5 and 6): _____

UNSWITCHED AUX + (term 6 and 7): _____

LOOP 8 POWERED + DEVICES (term 21 and 22): _____

TOTAL = (500 mA allowed): _____

ALPHA KEYPADS

Address Location

0 _____

1 _____

2 _____

3 _____

4 _____

5 _____

6 _____

7 _____

CONTROL LOCATION:

BREAKER # AND LOCATION:

0 0 0 0 0 0 0 #

**Installer
Combination**

0 1 9 1 2 3 4 E #

**User #1 - Master
Name:** _____

0 2 9 2 2 0 0 0 #

**User #2
Name:** _____

0 3 9 3 3 E 0 0 0 #

**User #3
Name:** _____

0 4 9 4 4 E 0 0 0 #

**User #4
Name:** _____

0 5 9 5 5 E 0 0 0 #

**User #5
Name:** _____

0 6 9 6 6 E 0 0 0 #

**User #6
Name:** _____

0 7 9 7 7 E 0 0 0 #

**User #7
Name:** _____

0 8 9 8 8 E 0 0 0 #

**User #8 -Guest
Name:** _____

0 9 0 0 1 1 #

**Arm/Combination
Option**

0 A 1 2 1 2 #

**Communications
Formats**

0 B 0 3 1 1 0 8 #

**Communications
Control**

0 C 0 0 0 0 0 0 #

Account #1

Phone #1 (1st 6 digits)

(Middle 6 digits)

(Last 6 digits)

0 D E 0 0 0 0 0 0 #

0 E 0 0 0 0 0 0 #

0 F 0 0 0 0 0 0 #

1 0 0 0 0 0 0 0 #

Account #2

Phone #2 (1st 6 digits)

(Middle 6 digits)

(Last 6 digits)

1 1 E 0 0 0 0 0 0 #

1 2 0 0 0 0 0 0 #

1 3 0 0 0 0 0 0 #

RPS Phone (1st 6 digits)

(Middle 6 digits)

(Last 6 digits)

1 4 E 0 0 0 0 0 0 #

1 5 0 0 0 0 0 0 #

1 6 0 0 0 0 0 0 #

1 7 1 0 E 1 0 0 # Loop 1 Codes
 1 9 3 0 E 3 0 0 # Loop 3 Codes
 1 B 5 0 E 5 0 0 # Loop 5 Codes
 1 D 7 0 E 7 0 0 # Loop 7 Codes

1 8 2 0 E 2 0 0 # Loop 2 Codes
 1 A 4 0 E 4 0 0 # Loop 4 Codes
 1 C 6 0 E 6 0 0 # Loop 6 Codes
 1 E 8 0 E 8 0 0 # Loop 8 Codes

1 F 1 2 1 3 2 3 # Loop 1 Control
 2 0 1 2 1 2 2 3 # Loop 2 Control
 2 1 1 2 1 2 2 3 # Loop 3 Control
 2 2 1 2 1 2 2 3 # Loop 4 Control
 2 3 1 2 1 1 2 3 # Loop 5 Control
 2 4 1 2 1 1 2 3 # Loop 6 Control
 2 5 1 2 1 9 3 3 # Loop 7 Control
 2 6 1 2 1 9 1 5 # Loop 8 Control

Description	Volts	Ohms

2 7 0 0 1 3 # Emergency Zone

2 8 0 0 1 1 # Fire Zone

2 9 0 0 1 2 # Police Zone

2 A 1 1 A 1 D 1 # Event Reports

2 B 0 0 1 6 # Test Report

2 C B 1 C 1 # Opening/Closing Reports

2 D 0 0 3 6 2 # Duress/Delays

2 E 1 1 0 0 0 # Audible/Visual Switches

2 F 1 0 0 1 # Unit Control

3 0 0 0 0 0 # Loop 1 Switches

3 1 0 1 0 0 # Loop 2 Switches

3 2 0 1 0 0 # Loop 3 Switches

3 3 0 1 0 0 # Loop 4 Switches

3 4 0 1 0 0 # Loop 5 Switches

3 5 0 1 0 0 # Loop 6 Switches

3 6 0 0 0 0 # Loop 7 Switches

3 7 0 0 0 0 # Loop 8 Switches