



motorola W230

Getting started guide

## accessories

more information

GOTO

accessories: [www.motorola.com](http://www.motorola.com)  
user guide: [www.motorola.com/support](http://www.motorola.com/support)



6803630S07

**congratulations!**  
Congratulations on your purchase of the cool Motorola W230 mobile phone.

Whether you're a talker, a texter or just love listening to music on the move, the W230 does it all.

We've crammed all the main features of your phone into this handy guide - you can even take the guide with you.

If you'd like even more information about how to use your new W230, visit [www.motorola.com/support/W230](http://www.motorola.com/support/W230).

So, let's go.

## your phone

### left soft key

Performs the function shown on the display above the key.

### send/answer key

Make and answer calls. Press from the home screen to see list of recently dialed calls.

### centre key

Select a highlighted option or open a menu when you see in the display.

### right soft key

Performs the function shown on the display above the key.

### power/end key

Press and hold to turn the phone on/off. Press and release to end phone calls. Exit menu system.

### navigation key

Scroll through lists and menus. Press left to access QuickTEXT.



## let's go

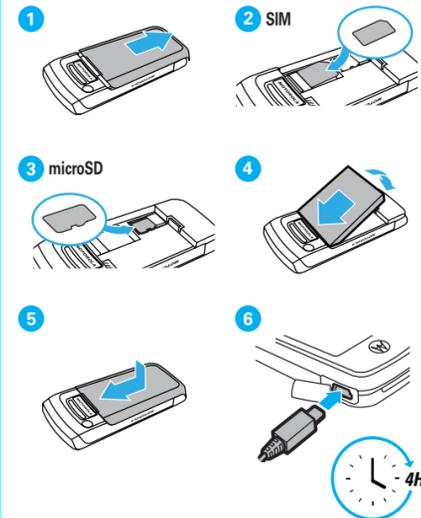

## basics

You may have mastered these already, but here are a few essential basics:

### turn it on & off

Press and hold for a few seconds to turn the phone on/off.

### menu navigation

Press the centre key to open the Main menu.

Press the navigation key up, down, right or left to highlight a menu option.

Press or **Select** (left soft key) to select the highlighted option.

Press when you see in the display to show menu options.

## customise

Here's your chance to make your phone easier and more enjoyable to use. So go on, add your personal touch.

### create shortcuts

Choose the features you want to access with a single key press from the home screen - really useful stuff:

Press > > **Personalise** > Home screen > Home keys

### set your screensaver and wallpaper

Change the wallpaper and screensaver images to ones that make you smile.

Press > > **Personalise** > Screensaver or Wallpaper

### set ringtone and volume

There are times when you want to hear your ringtone in all it's glory, and there are times when you don't.

Press > > **Settings** > Ring style

Choose from the pre-programmed styles, including Vibrate and Silent.

## shortcuts

A few shortcuts we think you'll find really useful:

### voicemail

Press and hold . If your voicemail number is pre-set, you will connect. If not, press then **Store**. Give your operator a call if you don't know the number.

### recent calls

Quickly view your call history by pressing > **Recent calls**. You can then choose to access your Received calls, Dialed calls or Call times.

### lock/unlock keys

Prevent accidental calls by pressing followed by . Your screen will go black and your keys are locked. Repeat to unlock.

### music player

Press **Music** (left soft key) from the home screen.

### quick text

To set quick text on your home screen press > > **Personalise** > Home screen > Home keys > Up/Down/Left/Right > Quick Txt.

## calls

Yes, your phone makes calls too! And it's very good at it.

### make a call

Enter a number and press .

### answer a call

When your phone rings or vibrates, press .

### end a call

Press .

## emergency calls

To call an emergency number, enter the emergency number and press .

Your service provider programs emergency phone numbers, (such as 999), that you can call under any circumstances, even when your phone is locked.

Emergency numbers vary by country. Your phone's pre-programmed emergency number(s) may not work in all locations, and sometimes an emergency call cannot be placed due to network, environmental or interference issues.

### redial a number

1 From the home screen, press to view a list of recently dialed calls.

2 Scroll to the entry you want to call and press .

## music

You love your new phone. You love your music. Imagine combining these two passions...imagine no longer:

### what you need

To use the music player, insert a microSD memory card, which is an optional accessory.

The music player supports MP3, MIDI, iMelody and AMR music file formats. You can copy music from a computer to your phone, where the music is stored on the memory card (see "USB drag & drop" later in this guide).

**TIP:** To access music stored on your microSD memory card, press > > **Multimedia** > Music library > > Switch storage devices.

### play music

Press > > **Multimedia** > Music library

Scroll to a song, playlist or album, and press **Play**.

**TIP:** From the home screen, press your phone's left soft key to access the music player faster.

## music player controls

function	Before music playback, through list
scroll up/down	press  up or down.
play/pause	Press .
fast forward	Press & hold  right (for at least two seconds).
rewind	Press & hold  left (for at least two seconds).
return to start of song	After first two seconds of song, press  left.
return to last song	Within first two seconds of song, press  left.

**Note:** Please use only Motorola approved accessories with this product.

For further support: [www.motorola.com](http://www.motorola.com)

## menu map

- Contacts**
- Recent calls**
  - Received calls
  - Dialled calls
  - NotePad
  - Call times
  - Call cost \*
  - Data times
  - Data volumes
- Messages**
  - Create
  - Inbox
  - Draft
  - Outbox
  - Quick notes
  - Voicemail
  - Browser msgs
  - MMS templates
- Extras**
  - Calculator
  - MyMenu
  - Alarm clock
  - Stop watch
  - Chat \*
  - Dialling services \*
  - STK \*
  - Calendar
- Games**
- WebAccess**
- Multimedia**
  - Pictures
  - Music library
  - FM radio
- Personalise**
  - Home screen
  - Main menu
  - Colour setting
  - Greeting
  - Wallpaper
  - Screensaver
  - Speed dial
- Settings**
  - Ring style
  - Call divert
  - In-call setup
  - Initial setup
  - Phone status
  - Headset
  - Network
  - Security
  - Easy prefix

This is a standard main menu layout. Your phone's menu may be a little different. \* Network dependent

## change front cover

Remove the battery cover. From the top of the device, wedge a thin object (eg.: your fingernails) between the cover and the main housing of the device until the two parts detach. Then, working down the phone, release the cover and slide off.



To replace the cover, first clip into the bottom of the phone and then work up the body, locking the tabs at the top. Finally, refit your battery cover.

**Warning:** Do not charge the battery with the phone or battery cover removed.

**Caution:** The front cover is made of plastic, so take care when handling. Also, when removing the cover take extra care not to expose it to dirt, dust, liquids, condensation or static electricity.

## contacts

Made a new friend? Urgently need to contact someone? No problem, saving and calling your contacts is effortless.

### save contact

1 Enter the number on the home screen and press **Store**.

2 Enter the contact details.

3 Press **Done** when you're finished.

### call a contact

1 Press > **Contacts**.

2 Scroll through the list to highlight the contact's number.

3 Press .

## messages

Messaging is great, everyone thinks so. Here are a few basics to get you going:

### send a message

1 Press > **Messages** > **Create**.

2 Select the message type.

3 Enter your message.

**Tip:** In a text entry screen, press to switch entry modes.

4 Press **OK** and scroll to a contact.

5 Press **Send** and scroll to any other contact/s you wish to add.

6 Once you have added the contact/s, press **Done**.

7 Press **Send** to send the message.



### read a message

When you receive a message you will see **New message** on your screen. Press **Read** to open the message. You can reply to the message by pressing **Reply**.

## FM radio

Listen to your favourite music or news programme.

1 Plug a 2.5 mm headset into your phone.

**Note:** The FM radio works only when the headset is plugged in.

2 Press > > **FM radio**

**To tune in a station,** press left or right.

**To scan available stations,** press and hold left or right. Repeat to go to more stations.

**To adjust volume,** press up or down.

**To turn off the radio,** press > **FM radio off**.

### store favourite stations

When listening to a station, press and hold a number key through to store the station as a preset for that number key. To select a preset station, press the number key for the station you want.

**TIP:** To share your favourite radio station press > > **FM radio** > **Options** > **Send station info**.

## USB drag & drop

Use the USB cable to connect your phone and PC, then simply drag & drop.

1 Insert one end of the USB cable into your phone and the other into your PC.

2 Press **Yes** to connect your phone as a storage device.

3 Use the **My Computer** window to find **Removable Device**.

4 Drag and drop your music, photos and other stuff that you want to copy.

5 When you're done, use the **Safely Remove Hardware** feature to finish.

**Note:** This product is compatible with Microsoft® Windows®, but may not work correctly with Mac® and Linux® OS.

For further support: <http://www.motorola.com/support/W230>

## status indicators

The home screen displays when you turn on the phone. Status indicators can appear across the top of the home screen:

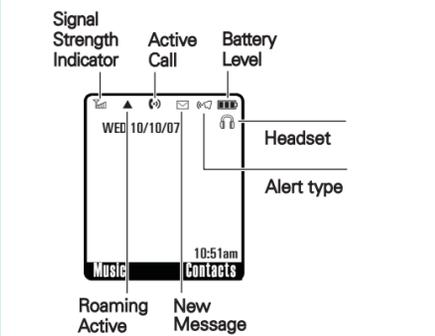

**Note:** Your phone's home screen may be different than the one shown.

Certain mobile phone features are dependent on the capabilities and settings of your service provider's network. Additionally, certain features may not be activated by your service provider, and/or the provider's network settings may limit the feature's functionality. Always contact your service provider about feature availability and functionality. All features, functionality, and other product specifications, as well as the information contained in this user's guide are based upon the latest available information and are believed to be accurate at the time of printing. Motorola reserves the right to change or modify any information or specifications without notice or obligation.

#### Software Copyright Notice

The Motorola products described in this manual may include copyrighted Motorola and third-party software stored in semiconductor memories or other media. Laws in the United States and other countries provide for Motorola and third-party software providers certain exclusive rights for copyrighted software, such as the exclusive rights to distribute or reproduce the copyrighted software. Accordingly, any copyrighted software contained in the Motorola products may not be modified, reverse-engineered, distributed, or reproduced in any manner to the extent allowed by law. Furthermore, the purchase of the Motorola products shall not be deemed to grant either directly or by implication, estoppel, or otherwise, any license under the copyrights, patents, or patent applications of Motorola or any third-party software provider, except for the normal, non-exclusive, royalty-free license to use that arises by operation of law in the sale of a product.

## Safety and General Information

**This section contains important information on the safe and efficient operation of your mobile device. Read this information before using your mobile device.**

### Exposure to Radio Frequency (RF) Energy

Your mobile device contains a transmitter and receiver. When it is ON, it receives and transmits RF energy. When you communicate using your mobile device, the system handling your call controls the power level at which your mobile device transmits.

Your Motorola mobile device is designed to comply with local regulatory requirements in your country concerning exposure of human beings to RF energy.

### Operational Precautions

For optimal mobile device performance and to be sure that human exposure to RF energy does not exceed the guidelines set forth in the relevant standards, always follow these instructions and precautions.

#### External Antenna Care

If your mobile device has an external antenna, use only a Motorola-supplied or approved replacement antenna. Use of antennas, modifications or attachments could damage the mobile device and/or may result in your device not complying with local regulatory requirements in your country.

DO NOT hold the external antenna when the mobile device is IN USE. Holding the external antenna affects call quality and may cause the mobile device to operate at a higher power level than needed.

#### Product Operation

When placing or receiving a phone call, hold your mobile device just like you would a landline phone.

If you wear the mobile device on your body, always place the mobile device in a Motorola-supplied or approved clip, holder, holster, case or body harness. If you do not use a body-worn accessory supplied or approved by Motorola - or if you hang your mobile device from a lanyard around your neck - keep the mobile device and its antenna at least 2.5 centimetres (1 inch) from your body when transmitting.

When using any data feature of the mobile device, with or without an accessory cable, position the mobile device and its antenna at least 2.5 centimetres (1 inch) from your body.

Using accessories not supplied or approved by Motorola may cause your mobile device to exceed RF energy exposure guidelines. For a list of Motorola-supplied or approved accessories, visit our web site at [www.motorola.com](http://www.motorola.com).

### RF Energy Interference/Compatibility

Nearly every electronic device is subject to RF energy interference from external sources if inadequately shielded, designed or otherwise configured for RF energy compatibility. In some circumstances your mobile device may cause interference with other devices.

### Follow Instructions to Avoid Interference Problems

Turn off your mobile device in any location where posted notices instruct you to do so. In an aircraft, turn off your mobile device whenever instructed to do so by airline staff. If your mobile device offers an airplane mode or similar feature, consult airline staff about using it in-flight.

### Implantable Medical Devices

If you have an implantable medical device, such as a pacemaker or defibrillator, consult your doctor before using this mobile device.

Persons with implantable medical devices should observe the following precautions:

- ALWAYS keep the mobile device more than 20 centimetres (8 inches) from the implantable medical device when the mobile device is turned ON.
- DO NOT carry the mobile device in the breast pocket.
- Use the ear opposite the implantable medical device to minimise the potential for interference.
- Turn OFF the mobile device immediately if you have any reason to suspect that interference is taking place.

Read and follow the directions from the manufacturer of your implantable medical device. If you have any questions about using your mobile device with your implantable medical device, consult your health care provider.

### Driving Precautions

Check the laws and regulations on the use of mobile devices in the area where you drive. Always obey them.

When using your mobile device while driving, please:

- Give full attention to driving and to the road. Using a mobile device may be distracting. Discontinue use if you cannot concentrate on driving.
  - Use hands-free operation, if available.
  - Pull off the road and park before making or answering a call if driving conditions do require.
  - Do not place a mobile device in the airbag deployment area.
- Responsible driving practices can be found in the "Smart Practices While Driving" section at the end of this guide and/or at the Motorola web site: [www.motorola.com/callsmart](http://www.motorola.com/callsmart).

**Note:** The use of wireless phones while driving may cause distraction. Discontinue a call if you can't concentrate on driving. Additionally, the use of wireless devices and their accessories may be prohibited or restricted in certain areas. Always obey the laws and regulations on the use of these products.

#### Operational Warnings

Obey all posted signs when using mobile devices in public areas.

#### Potentially Explosive Atmospheres

Areas with potentially explosive atmospheres are often but not always posted and can include fuelling areas such as below decks on boats, fuel or chemical transfer or storage facilities or areas where the air contains chemicals or particles, such as grain, dust or metal powders.

When you are in such an area, turn off your mobile device and do not remove, install or charge batteries. In such areas, sparks can occur and cause an explosion or fire.

#### Symbol Key

Your battery, charger or mobile device may contain symbols, defined as follows:

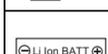
Symbol	Definition
	Important safety information follows.
	Do not dispose of your battery or mobile device in a fire.
	Your battery or mobile device may require recycling in accordance with local laws. Contact your local regulatory authorities for more information.
	Do not throw your battery or mobile device in a rubbish bin.
	Your mobile device contains an internal lithium ion battery.

Symbol	Definition
	Do not let your battery, charger or mobile device get wet.
	Listening at full volume to music or voice through a headset may damage your hearing.

#### Batteries and Chargers

**Caution: Improper treatment or use of batteries may present a danger of fire, explosion, leakage or other hazard. For more information, see the "Battery Use & Battery Safety" section in this user's guide.**

### Choking Hazards

Your mobile device or its accessories may include detachable parts, which may present a choking hazard to small children. Keep your mobile device and its accessories away from small children.

### Glass Parts

Some parts of your mobile device may be made of glass. This glass could break if the product is dropped on a hard surface or receives a substantial impact. If glass breaks, do not touch or attempt to remove. Stop using your mobile device until the glass is replaced by a qualified service centre.

### Seizures/Blackouts

Some people may be susceptible to epileptic seizures or blackouts when exposed to flashing lights, such as when playing video games. These may occur even if a person has never had a previous seizure or blackout.

If you have experienced seizures or blackouts or if you have a family history of such occurrences, please consult with your doctor before playing video games or enabling a flashing-lights feature (if available) on your mobile device.

Discontinue use and consult a doctor if any of the following symptoms occur: convulsion, eye or muscle twitching, loss of awareness, involuntary movements or disorientation. It is always a good idea to hold the screen away from your eyes, leave the lights on in the room, take a 15-minute break every hour and stop use if you are very tired.

### Caution About High Volume Usage

	Listening at full volume to music or voice through a headset may damage your hearing.
------------------------------------------------------------------------------------	---------------------------------------------------------------------------------------

### Repetitive Motion

When you repetitively perform actions such as pressing keys or entering finger-written characters, you may experience occasional discomfort in your hands, arms, shoulders, neck or other parts of your body. If you continue to have discomfort during or after such use, stop use and see a doctor.

## FCC Notice to Users

**The following statement applies to all products that have received FCC approval. Applicable products bear the FCC logo, and/or an FCC ID in the format FCC-ID:xxxxxx on the product label.**

Motorola has not approved any changes or modifications to this device by the user. Any changes or modifications could void the user's authority to operate the equipment. See 47 CFR Sec. 15.21.

This device complies with part 15 of the FCC Rules. Operation is subject to the following two conditions: (1) This device may not cause harmful interference, and (2) this device must accept any interference received, including interference that may cause undesired operation. See 47 CFR Sec. 15.19(3).

This equipment has been tested and found to comply with the limits for a Class B digital device, pursuant to part 15 of the FCC Rules. These limits are designed to provide reasonable protection against harmful interference in a residential installation. This equipment generates, uses and can radiate radio frequency energy and, if not installed and used in accordance with the instructions, may cause harmful interference to radio communications. However, there is no guarantee that interference will not occur in a particular installation. If this equipment does cause harmful interference to radio or television reception, which can be determined by turning the equipment off and on, the user is encouraged to try to correct the interference by one or more of the following measures:

- Reorient or relocate the receiving antenna.
- Increase the separation between the equipment and the receiver.
- Connect the equipment to an outlet on a circuit different from that to which the receiver is connected.
- Consult the dealer or an experienced radio/TV technician for help.

## Information from the World Health Organization

Present scientific information does not indicate the need for any special precautions for the use of mobile phones. If you are concerned, you may want to limit your own or your children's RF exposure by limiting the length of calls or by using handsfree devices to keep mobile phones away from your head and body.

Source: WHO Fact Sheet 193

Further information:

<http://www.who.int./peh-emf>

## Caring for the Environment by Recycling

This symbol on a Motorola product means the product should not be disposed of with household waste.

## Disposal of your Mobile Device and Accessories

Please do not dispose of mobile devices or electrical accessories (such as chargers, headsets or batteries) with your household waste. These items should be disposed of in accordance with the national collection and recycling schemes operated by your local or regional authority. Alternatively, you may return unwanted mobile devices and electrical accessories to any Motorola Approved Service Centre in your region. Details of Motorola approved national recycling schemes and further information on Motorola recycling activities can be found at [www.motorola.com/recycling](http://www.motorola.com/recycling).

### Disposal of your Mobile Device Packaging and User's Guide

Product packaging and user's guides should only be disposed of in accordance with national collection and recycling requirements. Please contact your regional authorities for more details.

## Privacy and Data Security

Motorola understands that privacy and data security are important to everyone. Given that some features of your mobile device may affect your privacy or data security, please follow these recommendations to enhance protection of your information:

- Monitor access**—Keep your mobile device with you and do not leave it where others may have unmonitored access. Lock your device's keypad where this feature is available.
- Keep software up to date**—If Motorola or a software/application vendor releases a patch or software fix for your mobile device which updates the device's security, install it as soon as possible.

- Erase before recycling**—Delete personal information or data from your mobile device prior to disposing of it or turning it in for recycling. For step-by-step instructions on how to delete all personal information from your device, see the section entitled "master clear" or "delete data" in this user's guide.

**Note:** For information on backing up your mobile device data before erasing it, go to [www.motorola.com](http://www.motorola.com) and then navigate to the "downloads" section of the consumer web page for "Motorola Backup" or "Motorola Phone Tools."

- Understanding AGPS**—In order to comply with the emergency caller location requirements of Ofcom, certain Motorola mobile devices incorporate *Assisted Global Positioning System* (AGPS) technology. AGPS technology also can be used in non-emergency applications to track and monitor a user's location, for example, to provide driving directions. Users who prefer not to permit such tracking and monitoring should avoid using such applications.

If you have further questions regarding how use of your mobile device may impact your privacy or data security, please contact Motorola at [privacy@motorola.com](mailto:privacy@motorola.com), or contact your service provider.

## Smart practices while driving

### Drive Safe, Call Smart SM

**Check the laws and regulations on the use of mobile devices and their accessories in the areas where you drive. Always obey them. The use of these devices may be prohibited or restricted in certain areas. Go to [www.motorola.com/callsmart](http://www.motorola.com/callsmart) for more information.**

Your mobile device lets you communicate by voice and data, almost anywhere, anytime, wherever wireless service is available and safe conditions allow. When driving a car, driving is your first responsibility. If you choose to use your mobile device while driving, remember the following tips:

- Get to know your Motorola mobile device and its features such as speed dial and redial.** If available, these features help you to place your call without taking your attention off the road.
- When available, use a hands-free device.** If possible, add an additional layer of convenience to your mobile device with one of the many Motorola Original hands-free accessories available today.
- Position your mobile device within easy reach.** Be able to access your mobile device without removing your eyes from the road. If you receive an incoming call at an inconvenient time, if possible, let your voice mail answer it for you.
- Let the person you are speaking with know you are driving; if necessary, suspend the call in heavy traffic or hazardous weather conditions.** Rain, sleet, snow, ice, and even heavy traffic can be hazardous.
- Do not take notes or look up phone numbers while driving.** Jotting down a "to do" list or going through your address book takes attention away from your primary responsibility—driving safely.
- Dial sensibly and assess the traffic; if possible, place calls when your car is not moving or before pulling into traffic.** If you must make a call while moving, dial only a few numbers, check the road and your mirrors, then continue.
- Do not engage in stressful or emotional conversations that may be distracting.** Make people you are talking with aware you are driving and suspend conversations that can divert your attention away from the road.
- Use your mobile device to call for help.** Dial 999 or other local emergency number in the case of fire, traffic accident, or medical emergencies.
- Use your mobile device to help others in emergencies.** If you see a road accident, crime in progress, or other serious emergency where lives are in danger, call 999 or other local emergency number, as you would want others to do for you.
- Call roadside assistance or a special non-emergency wireless assistance number when necessary.** If you see a broken-down vehicle posing no serious hazard, a broken traffic signal, a minor traffic accident where no one appears injured, or a vehicle you know to be stolen, call roadside assistance or other special non-emergency wireless number.<sup>2</sup>

Additional Information can be found on the websites of the World Health Organization (<http://www.who.int/emf/>) or Motorola, Inc. (<http://www.motorola.com/rfhealth>).

## Specific Absorption Rate Data

**This model meets international guidelines for exposure to radio waves.**

Your mobile device is a radio transmitter and receiver. It is designed not to exceed the limits for exposure to radio waves recommended by international guidelines. These guidelines were developed by the independent scientific organization ICNIRP and include safety margins designed to assure the protection of all persons, regardless of age and health.

The guidelines use a unit of measurement known as the Specific Absorption Rate, or SAR. The ICNIRP SAR limit for mobiles devices used by the general public is 2 W/kg and the highest SAR value for this device when tested at the ear was 0.96 W/kg.<sup>3</sup>

As mobile devices offer a range of functions, they can be used in other positions, such as on the body as described in this user guide.<sup>4</sup> In this case, the highest tested SAR value is 0.5 W/kg.

As SAR is measured utilising the device's highest transmitting power, the actual SAR of this device while operating is typically below that indicated above. This is due to automatic changes to the power level of the device to ensure it only uses the minimum level required to reach the network.

While there may be differences between the SAR levels of various phones and at various positions, they all meet the governmental requirements for safe exposure. Please note that improvements to this product model could cause differences in the SAR value for later products; in all cases, products are designed to be within the guidelines.

The World Health Organization has stated that present scientific information does not indicate the need for any special precautions for the use of mobile devices. They note that if you want to reduce your exposure then you can do so by limiting the length of calls or using a "hands-free" device to keep the mobile phone away from the head and body.

Additional Information can be found on the websites of the World Health Organization (<http://www.who.int/emf/>) or Motorola, Inc. (<http://www.motorola.com/rfhealth>).

## WARRANTY INFORMATION

Motorola guarantees to you, the original purchaser, the Personal Communicator and accessories which you have purchased from an authorised Motorola dealer (the "Products"), to be in conformance with the applicable Motorola specifications current at the time of manufacture for a term of 1 year from date of purchase of the Product(s) (Warranty Term).

You must inform Motorola of the lack of conformity to the applicable specifications of any of the Products within a period of two (2) months from the date on which you detect a defect in material, workmanship or lack of conformity and in any event within a term not to exceed the Warranty Term, and must immediately submit the Product for service to Motorola's Authorised Repair or Service Centre. Motorola shall not be bound by Product related statements not directly made by Motorola nor any warranty obligations applicable to the seller.

A list of the Motorola Call Centre numbers is enclosed with this Product. During the Warranty term, Motorola will, at its discretion and without extra charge, as your exclusive remedy, repair or replace your Product which does not comply with this warranty; or failing this, to reimburse the price of the Product but reduced to take into account the use you have had of the Product since it was delivered. This warranty will expire at the end of the Warranty Term.

This is the complete and exclusive warranty for a Motorola Personal Communicator and accessories and in lieu of all other warranties, terms and conditions, whether express or implied.

Where you purchase the product other than as a consumer, Motorola disclaims all other warranties, terms and conditions express or implied, such as fitness for purpose and satisfactory quality.

In no event shall Motorola be liable for damages nor loss of data in excess of the purchase price nor for any incidental special or consequential damages<sup>5</sup> arising out of the use of inability to use the Product, to the full extent such may be disclaimed by law. This Warranty does not affect any statutory rights that you may have if you are a consumer, such as a warranty of satisfactory quality and fit for the purpose for which products of the same type are normally used under normal use and service, nor any rights against the seller of the Products arising from your purchase and sales contract.

### HOW TO GET WARRANTY SERVICE?

In most cases the authorised Motorola dealer which sold and/or installed your Motorola Personal Communicator and original accessories will honour a warranty claim and/or provide warranty service. Alternatively, for further information on how to get warranty service, please contact either the customer service department of your service provider or Motorola's call centre at (GB) +44 (0) 871 641 2130, (BE) +32 (0) 2 700 16 60, (CH) 0800 553 109, (IE) +353 1850 909 555.

### CLAIMING

In order to claim the warranty service, you must return the Personal Communicator and/ or accessories in question to Motorola's Authorised Repair or Service Centre in the original configuration and packaging as supplied by Motorola. Please avoid leaving any supplementary items like SIM cards. The Product should also be accompanied by a label with your name, address, and telephone number, name of operator and a description of the problem. In the case of vehicular installation, the vehicle in which the Personal Communicator is installed should be driven to the Authorised Repair or Service Centre, as analysis of any problem may require inspection of the entire vehicular installation. In order to be eligible to receive warranty service, you must present your receipt of purchase or a comparable substitute proof of purchase bearing the date of purchase. The phone should also clearly display the original complete electronic serial number (IMEI) and mechanic serial number (MSN). Such information is contained with the Product.

You must ensure that any and all repairs or servicing is handled at all times by a Motorola Authorised Service Centre in accordance with the Motorola Service requirements.

In some cases, you may be requested to provide additional information concerning the maintenance of the Products by Motorola Authorised Service Centres only, therefore it is important to keep a record of any previous repairs, and make them available if questions arise concerning maintenance.

### CONDITIONS

This warranty will not apply if the type or serial numbers on the Product have been altered, deleted, duplicated, removed, or made illegible. Motorola reserves the right to refuse free-of-charge warranty service if the requested documentation can not be presented or if the information is incomplete, illegible or incompatible with the factory records.

<sup>5</sup> including without limitation loss of use, loss of time, loss of data, inconvenience, commercial loss, lost profits or savings.

Repair, at Motorola's option, may include reflashing of software, the replacement of parts or boards with functionally equivalent, reconditioned or new parts or boards.

Replaced parts, accessories, batteries, or boards are warranted for the balance of the original warranty time period. The Warranty Term will not be extended. All original accessories, batteries, parts, and Personal Communicator equipment that have been replaced shall become the property of Motorola. Motorola does not warrant the installation, maintenance or service of the products, accessories, batteries or parts.

Motorola will not be responsible in any way for problems or damage caused by any ancillary equipment not furnished by Motorola which is attached to or used in connection with the Products, or for operation of Motorola equipment with any ancillary equipment and all such equipment is expressly excluded from this warranty.

When the Product is used in conjunction with ancillary or peripheral equipment not supplied by Motorola, Motorola does not warrant the operation of the Product/ peripheral combination and Motorola will not honour any warranty claim where the Product is used in such a combination and it is determined by Motorola that there is no fault with the Product. Motorola specifically disclaims any responsibility for any damage, whether or not to Motorola equipment, caused in any way by the use of the Personal Communicator, accessories, software applications and peripherals (specific examples include, but are not limited to: batteries, chargers, adapters, and power supplies) when such accessories, software applications and peripherals are not manufactured and supplied by Motorola.

A list of the Motorola Call Centre numbers is enclosed with this Product.

During the Warranty term, Motorola will, at its discretion and without extra charge, as your exclusive remedy, repair or replace your Product which does not comply with this warranty; or failing this, to reimburse the price of the Product but reduced to take into account the use you have had of the Product since it was delivered. This warranty will expire at the end of the Warranty Term.

This is the complete and exclusive warranty for a Motorola Personal Communicator and accessories and in lieu of all other warranties, terms and conditions, whether express or implied.

Where you purchase the product other than as a consumer, Motorola disclaims all other warranties, terms and conditions express or implied, such as fitness for purpose and satisfactory quality.

In no event shall Motorola be liable for damages nor loss of data in excess of the purchase price nor for any incidental special or consequential damages<sup>5</sup> arising out of the use of inability to use the Product, to the full extent such may be disclaimed by law. This Warranty does not affect any statutory rights that you may have if you are a consumer, such as a warranty of satisfactory quality and fit for the purpose for which products of the same type are normally used under normal use and service, nor any rights against the seller of the Products arising from your purchase and sales contract.

Defects or damage resulting from use of the Product in other than its normal and customary manner.

- Defects or damage from misuse, access to incompatible sources, accident or neglect.
- Defects or damage from improper testing, operation, maintenance, installation, adjustment, unauthorised software applications or any alteration or modification of any kind.
- Breakage or damage to antennas unless caused directly by defects in material or workmanship.
- Products disassembled or repaired other than by Motorola in such a manner as to adversely affect performance or prevent adequate inspection and testing to verify any warranty claim.
- Defects or damage due to range, coverage, availability, grade of service, or operation of the cellular system by the cellular operator.
- Defects or damage due to moisture, liquid or spills of food.
- Control unit coil cords in the Product that are stretched or have the modular tab broken.
- All plastic surfaces and all other externally exposed parts that are scratched or damaged due to customer normal use.
- Leather cases (which are covered under separate manufacturer's warranties).
- Products rented on a temporary basis.
- Periodic maintenance and repair or replacement of parts due to normal wear and tear.

**Note:** The talk-time, stand-by time and total life cycle of a Motorola rechargeable battery for your Personal Communicator will depend on usage conditions and network configurations. As a consumable product, the specifications indicate that you should be able to obtain optimum performance for your Motorola Personal Communicator within the first six months from date of purchase and up to (200) charges (Optimum Performance Time).

The warranty for Motorola rechargeable batteries becomes void if (i) the batteries are charged other than by Motorola approved battery chargers specified for the charging of the battery, (ii) any of the seals on the battery are broken or show evidence of tampering, (iii) the battery is used in equipment or service other than the cellular telephone equipment for which it is specified.

Depending on operating conditions and your usage habits, wear and tear might take place of components including mechanical problems related to Product housing, paint, assembly, sub-assemblies, displays and keyboards and any accessories which are not part of the Product's in-box configuration. The rectification of faults generated through wear and tear and the use of consumable items like batteries beyond their Optimum Performance Time as indicated in the product manual is considered to be your responsibility and therefore Motorola will not provide the free Warranty repair service for these items.

### INSTALLED DATA

Please make and retain a note of all data you have inserted into your Product, for example, names, addresses, phone numbers, user and access codes, notes, etc, before submitting your Product for a Warranty service as such data may be deleted or erased as part of the repair or service process.

Please note if you have downloaded material onto your Product, for example ring tones, ring tones, screensavers, wallpaper, games, etc. these may be deleted or erased as part of the repair process or testing process. Motorola shall not be responsible for such matters. The repair or testing process should not affect any such material that was installed by Motorola on your Product as a standard feature.

## OUT OF WARRANTY REPAIRS

If you request Motorola to repair your Product any time after the Warranty term or when this warranty does not apply due to the nature of the defect or fault, then Motorola may at its discretion carry out such repairs subject to you paying Motorola its fees for such a repair or it may refer you to an authorised third party to carry out such repairs.

### battery tips

- Motorola recommends you always use Motorola-branded batteries and chargers.** The warranty does not cover damage caused by non-Motorola batteries and/or chargers. **Caution:** Use of unapproved batteries or chargers may present a risk of fire, explosion, leakage, or other hazard. Improper battery use, or use of a damaged battery, may result in a fire, explosion, or other hazard.

- Children should be supervised when using the battery.
- Important:** Motorola mobile devices are designed to work best with approved batteries. If you see a message on your display such as **Invalid Battery or Unable to Charge**, take the following steps:
- Remove the battery and inspect it to confirm that it bears a Motorola "Original Equipment" hologram;
- If there is no hologram, the battery is not an approved battery;
- If there is a hologram, replace the battery and attempt to recharge it;
- If the message remains, contact a Motorola authorised service centre.

- New batteries or batteries stored for a long time may take longer to charge.
- Charging precautions:** When charging your battery, keep it near room temperature. Never expose batteries to temperatures below 0°C (32°F) or above 45°C (113°F) when charging. Always take your mobile device with you when you leave your vehicle
- When storing your battery, keep it in a cool, dry place.
- It is normal for the battery life to decrease over time and for the battery to exhibit shorter runtimes between charges or require more frequent or longer charging times.

- Avoid damage to battery and mobile device.** Do not disassemble, open, crush, bend, deform, puncture, shred or submerge the battery or mobile device. Avoid dropping the battery or mobile device, especially on a hard surface. If your battery or mobile device has been subjected to such damage, take it to a Motorola authorised service centre before using. Do **not** attempt to dry it with an appliance or heat source, such as a hair dryer or microwave oven.

- Take care when handling a charged battery**—particularly when placing it inside a pocket, purse or other container with metal objects. Contact with metal objects (such as jewellery, keys, beaded chains) could complete an electrical circuit (short circuit), causing the battery to become very hot, which could cause damage or injury.

Promptly dispose of used batteries in accordance with local regulations. Contact your local recycling centre for proper battery disposal.

**Warning:** Never dispose of batteries in a fire because they may explode.