



# USER MANUAL

# AX2065A

## active vertical array loudspeaker

### KEY FEATURES

- High output line array element
- Compact size, very good output-to-weight ratio
- High quality, low compression, low distortion HF driver
- Very stable horizontal coverage
- Transmission Line back loading for clean mid-bass reproduction
- Natural sound Transmission Line HF projection wave-forming device
- 96KHz / 40 bit floating point CORE processing with PRONET remote control
- Digitally controlled Class D amplifier module with SMPS

### INTRODUCTION

The AX2065A Vertical Line Array element is designed for a wide range of sound reinforcement applications where a flexible and easy to use vertical array systems is needed. The AX2065A has been designed both for rental live sound applications and for fixed installations and has been engineered for the simplest use possible but without sacrificing anything in sound quality and performance.

The high frequency range is reproduced by a low-distortion compression driver, equipped with very light-weight Titanium diaphragms and a special new suspension design for very natural sound. A transmission line wave-forming waveguide has been used to load the HF driver, in order to provide a detailed and natural sound and to achieve a long-distance HF projecting capacity.

The two 6.5" woofers are back loaded by a short hybrid transmission line that minimizes the effect of the box resonances and eliminates the "boxy" mid-bass sound commonly obtained from regular bassreflex enclosures. The AX2065A is processed by 40bit, 96kHz floating point CORE DSP and powered by DA SERIES digital power modules, a new generation of CLASS D power amplifier with digitally-controlled SMPS. The DA module employed for powering the AX2065A delivers in an ultra-compact package a maximum power of 2000W and each AX2065A is able to power an additional passive AX2065P module through the available power output on the back panel. This feature will allow to assemble very competitive hybrid solutions both for rental and installation applications.

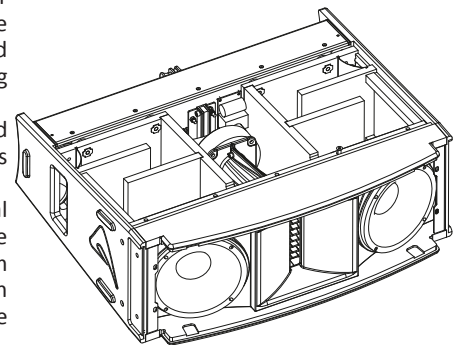
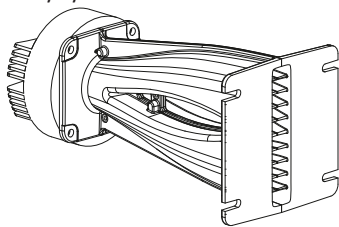

### TECHNICAL SPECIFICATION

<b>Acoustical</b>		Remote Controls	PRONET control software
System type	Line Array Element Short Transmission Line LF Back Loading Acoustic Transmission Line HF Waveguide	Network protocol	CANBUS
Low frequency transducer	Two 6.5" (165 mm), 1.5" (38 mm) aluminium voice coil, 16Ω each, paralleled	Amplifier Type	Class D with Variable Switching Frequency and SMPS
High frequency transducer	One 1.4" driver, 2.5" (64 mm) edgewound voice coil, titanium diaphragm, 8Ω each, paralleled	Output Power	2x 1000 W
Frequency response (±3 dB)	80 Hz – 18 kHz (Processed)	Mains Voltage Range (Vac)	230 V~ ±15% or 115 V~ ±15% 50/60 Hz
Horizontal Coverage Angle	110° (-6 dB)	Mains Connector	PowerCon® (NAC3MPA + NAC3MPB)
Vertical Coverage Angle	12° (-6 dB)	Consumption*	700 W (nominal) 1700 W (max)
Maximum Peak SPL @ 1m	129 dB	IN / OUT Connectors	Neutrik XLR-M / XLR-F / Speakon NL4MP
<b>Electrical</b>		IN / OUT Network Connectors	ETHERCON® (NE8FAV)
Input Impedance	20 kΩ balanced	<b>Mechanical</b>	
Input Sensitivity	+4 dBu / 1.25 V	Width	583 mm (22.95")
Signal Processing	CORE processing, 96kHz / 40bit floating point SHARC DSP, 24 bit AD/DA converters	Height	244 mm (9.60")
Direct access Controls	4 Presets: Standard, Long Throw, Down Fill-Single Box, User. Network Termination, GND Link	Depth	481 mm (18.93")
		Taper angle	5°
		Construction	15 mm, reinforced Phenolic Birch
		Paint	High resistance, water based paint
		<b>Suspension system</b>	
		Front Suspension	Aluminium Fast Link structure with ¼ Fast Pin
		Back Suspension	High Strength Steel with ¼ Fast Pin
		Net Weight	22.5 Kg (49.6 lbs.)

\* Nominal consumption is measured with pink noise with a crest factor of 12 dB, this can be considered a standard music program.





**MECHANICAL DRAWING**

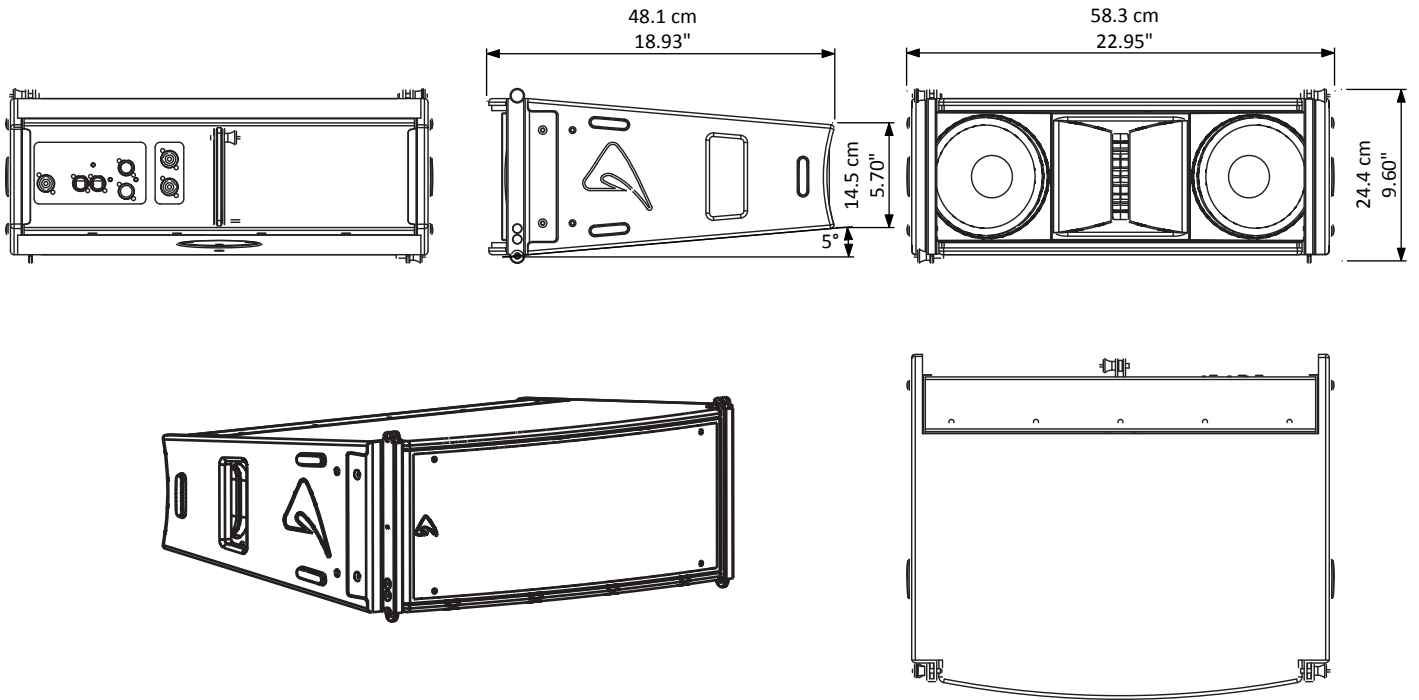

**OPTIONAL ACCESSORIES**

<b>AXCASE05</b>	Carrying Case for 4 box unit + Flying Bar	<b>AX2065P</b>	Passive vertical array loudspeaker
<b>AXCASE06</b>	Carrying Case for 4 box unit	<b>USB2CAN</b>	PRONET network converter
<b>NAC3FCA</b>	Neutrik Powercon® BLUE PLUG	<b>KPTSW215</b>	Fly bar for Axiom AX2065 and SW215 Loudspeakers
<b>NAC3FCB</b>	Neutrik Powercon® WHITE PLUG	<b>KPTAX2065</b>	Fly bar for Axiom AX2065 only
<b>NE8MCB</b>	Neutrik Ethercon PLUG	<b>AXFEETKIT</b>	Kit Of 6pcs BOARDACF01 M10 foot for stacked installation
<b>NC3MXXBAG</b>	Neutrik XLR-M	<b>KPAX265</b>	Pole Adaptor
<b>NC3FXXBAG</b>	Neutrik XLR-F	<b>KP010</b>	0° to 10° tilt adaptor
<b>SW215A</b>	Active Subwoofer	<b>DHSS10M20</b>	Sub-Speaker ø35mm Pole with M20 screw
<b>SW215FA</b>	Flyable Active Subwoofer	<b>RAINCOV2065</b>	Rain cover for input sockets

see <http://www.axiomproaudio.com/> for detailed description and other available accessories.

**AX2065 used as conventional system**

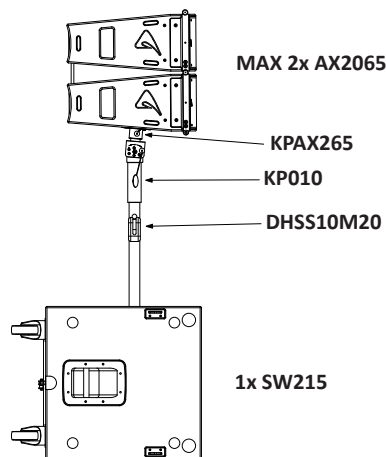

**SPARE PARTS**

<b>NAC3MPA</b>	Neutrik Powercon® BLUE SOCKET	<b>91DSPKT3</b>	Input & DSP module with panel assembly
<b>NAC3MPB</b>	Neutrik Powercon® WHITE SOCKET	<b>98AXM6W16</b>	6.5" woofer - 1.5" VC
<b>94SPI2265</b>	Locking Pin for AX2265	<b>98DRI2065</b>	1.4" - 2.5" compression driver
<b>PLG716</b>	Straight Shackles 16 mm for Fly bar	<b>98MBN2065</b>	titanium diaphragm for 1.4" driver
<b>91AMD2065</b>	Power amplifier module with mechanical assembly		





## I/O AND CONTROL OPERATIONS

**MAINS IN** - Powercon® NAC3FCA power input connector (blue). To switch the amplifier on, insert the Powercon® connector and turn it clockwise into the ON position. To switch the amplifier off, pull back the switch on the connector and turn it counter-clockwise into the POWER OFF position.

**WARNING!** In the case of product failure or fuse replacement, disconnect the unit completely from the mains power. The power cable must only be connected to a socket corresponding to the specifications indicated on the amplifier unit. The power supply must be protected by a suitably rated thermo-magnetic breaker. Preferably use a suitable switch to power on the whole audio system leaving the Powercon® always connected to each speaker, this simple trick extend the life of the Powercon® connectors.

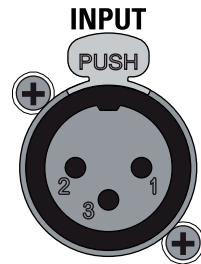

**MAINS OUT** - Powercon® NAC3FCB power output connector (grey). This is connected in parallel with the MAINS ~ / IN. The maximum load applicable depends on the mains voltage. With 230V~ we suggest to link a maximum of 4 AX2065A loudspeakers, with 120V~ we suggest to link a maximum of 2 AX2065A loudspeakers.

**INPUT** - Audio signal input with locking XLR connector. It has a fully electronically balanced circuitry including AD conversion for the best S/N ratio and input headroom.

**LINK** - A direct connection from the input connector to link other speakers with same audio signal.

**ON** - This LED indicates power on status.

**PROT** - This red LED lights when the amplifier module is in protect mode for an internal fault and, consequently, the amplifier is muted.

**SIGN/LIMIT** - This LED lights in green to indicate the presence of the signal and lights in red when an internal limiter reduces the input level.

**GND LIFT** - This switch lift the ground of the balanced audio inputs from the earth-ground of the amplifier module.

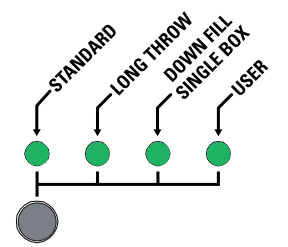
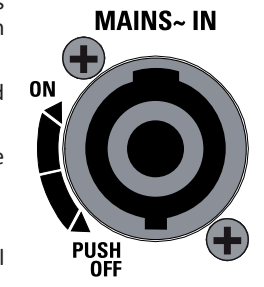
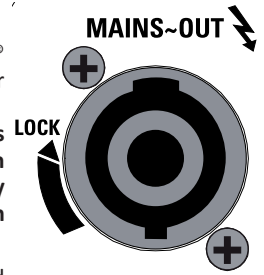
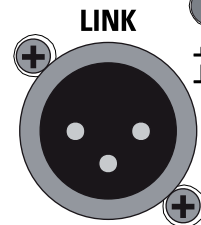

**PRESET BUTTON** - This button has two function:

1) Pressing it while powering on the unit:

**ID ASSIGN** the internal DSP assigns a new ID to the unit for the PRONET remote control operation. Each loudspeaker must have a unique ID to be visible in the PRONET network. When you assign a new ID, all the other loudspeakers with the ID already assigned must be ON and connected to the network.

2) Pressing it with the unit ON you can select the DSP PRESET. The selected PRESET is indicated by the corresponding LED:

**STANDARD** This PRESET is suitable for vertical flow arrays that may range from 4 to 8 boxes or for the centre region of a bigger flow array. It can be used also for stacked arrays.

**LONG THROW** This PRESET can be used in arrays bigger than 6 or 8 boxes and loaded in the top 1 or 2 boxes in order to obtain a more even distribution of the sound pressure, especially if they point very far away or to the upper deck of a large theatre.

**DOWN FILL / SINGLE BOX** This PRESET, which features a much smoother high frequency response, can be loaded in the bottom boxes (usually 1 or 2 boxes) of a large flow array, in order to reach conveniently the audience close to the stage. This preset could be very useful also when the box is used just on its own as a Front Fill element in the front of very large stages.

**USER** This LED lights when the USER PRESET is loaded. This preset corresponds to USER MEMORY no. 1 of the DSP and, as a factory setting, it's the same to STANDARD. If you want to modify it, you have to connect the unit to a PC, edit the parameters with PRONET software and save the PRESET into USER MEMORY no. 1. *Note: see also the PRONET example further on this manual.*

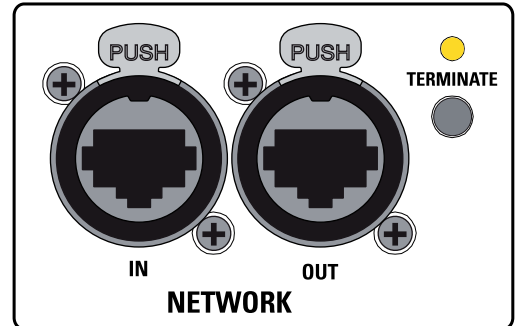

**NETWORK IN/OUT** - These are a standard RJ45 CAT5 connectors (with optional NEUTRIK NE8MC RJ45 cable connector carrier), used for PRONET network transmission of remote control data over long distance or multiple unit applications.

**TERMINATE** - In a PRONET network the last loudspeaker device must be terminated (with an inner load resistance) especially in a long run cabling: press this switch if you want to terminate the unit.

**POWER OUT** - AX2065A is able to power an additional passive AX2065P module through the available power output on the back panel.

**WARNING:** connect a single AX2065P module only.

MF> 1+/1-  
HF> 2+/2-

**POWER OUT**  
AX2065P ONLY

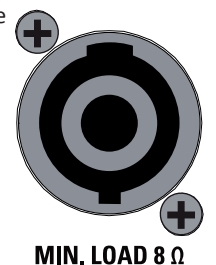





The "Assign ID" procedure for a device makes the internal network controller to perform two operations: reset the current ID; search the first free ID in the network, starting from ID=1. If no other devices are connected (and powered on), the controller assume ID=1, that is the first free ID, otherwise it searches the next one left free.

These operations ensure that every device has it's own unique ID, if you need to add a new device to the network you simply repeat the operation of step 4. Every device maintains its ID also when it is turned-off, because the identifier is stored in the internal memory and it is cleared only by another "Assign ID" step, as explained above. This means that if your network is made always of the same devices the assigning ID procedure must be executed only the first time the system is turned on.

**For more detailed instruction about PRONET see the PRONET USER'S MANUAL included with the software.**

**Useful tools to set up properly a vertical array system**

This is a list of tools that can be very useful to set properly a vertical array system.



**CABLE TESTER**

It is a good practice to check all cables before each installation, because even one faulty cable can compromise heavily the system performance.



**INCLINOMETER WITH LEVER**

This tool can be used to verify the vertical array angle. It can be used at the top or at the bottom of the array In this case you have to sum all splay angles, so the maximum precision is needed for aiming the vertical array, particularly for long throw applications.



**LASER DISTANCE METER**

This instrument can be useful to measure the height of the vertical array and to know the distance between FOH-Subs and FOH-Array for setting the delay time.



**SMART or similar acoustic measurement system**

These are useful to measure delays, phase and response of the system.

**EXAMPLE OF INSTALLATION IN A THEATRE WITH BALCONY**

Here below you can see an example of the use of different PRESETS in an AX2065 flown array installed in a big theatre with balcony. The TOP BOXES of the array are aiming at the balcony while the DOWN FILL box is aiming at the audience close to the stage.

TOP BOXES: the power level at the end of the balcony is lower, as well as the high frequency level.

DOWN FILL BOXES: the power level in the proximity of the stage is higher, as well as the high frequency level.

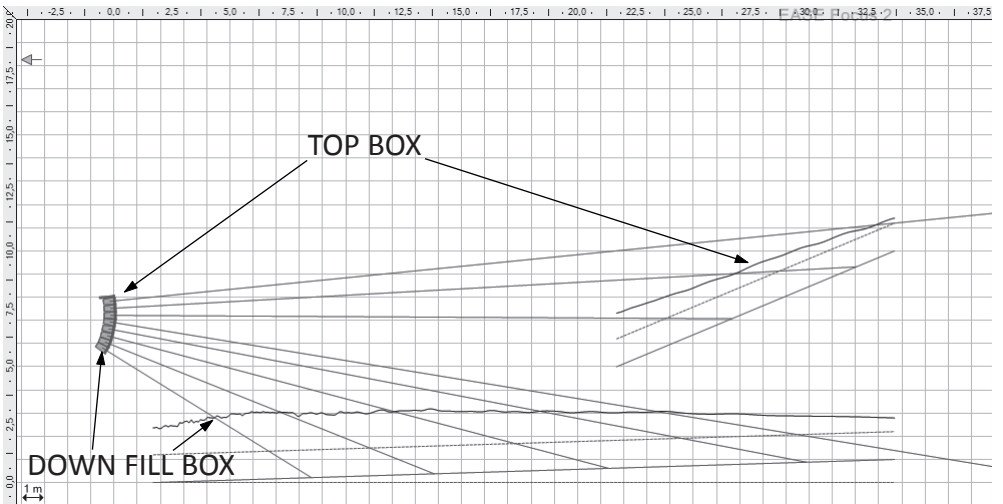

**AX2065A - PRESET RESPONSE**

**PRESET USING EXAMPLE**

In order to optimize the array performances for this specific application, the PRESETS should be used in the following way.

Load the STANDARD preset in the central boxes.

Load the LONG THROW preset in the TOP 1 or 2 boxes, in order to compensate the loss of power level and high frequencies of the program sent the upper deck of the theatre.

Load the DOWN FILL / SINGLE BOX preset in the BOTTOM box in order to smooth the high frequency content of the program sent to the audience close to the stage.

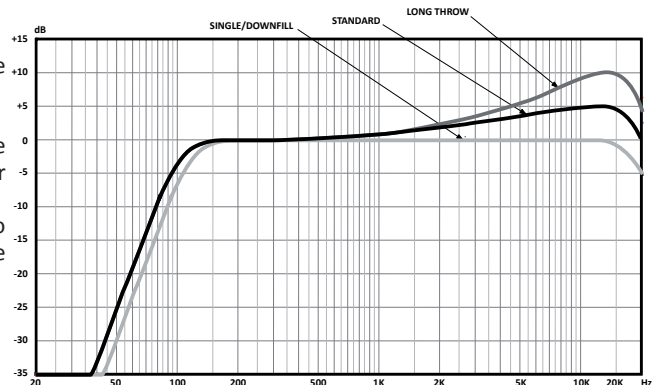





## PREDICTION: EASE Focus 2

To aim correctly a complete system we suggest to use always the Aiming Software - EASE Focus 2: The EASE Focus 2 Aiming Software is a 3D Acoustic Modelling Software that serves for the configuration and modelling of Line Arrays and conventional speakers close to reality. It only considers the direct field, created by the complex addition of the sound contributions of the individual loudspeakers or array components.

The design of EASE Focus is targeted at the end user. It allows the easy and quick prediction of the array performance in a given venue. The scientific base of EASE Focus stems from EASE, the professional electro- and room acoustic simulation software developed by AFMG Technologies GmbH. It is based on the EASE GLL loudspeaker data file required for its use: **AXIOM\_AX Series\_v2\_1.GLL**, please note that the version must be 2.0 or more. The GLL file contains the data that defines the Line Array with regard to its possible configurations as well as to its geometrical and acoustical properties.

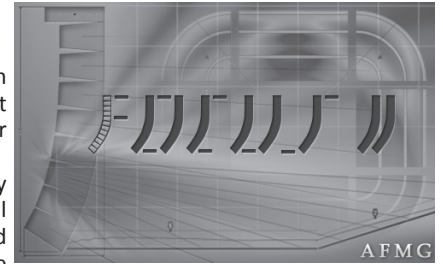

Download the EASE Focus 2 app from the AXIOM website at <http://www.axiomproaudio.com/> clicking on downloads section of the product.

Use the menu option **Edit / Import System Definition File** to import the file **AXIOM\_AX Series\_v2\_1.gll** from the installation Data folder, the detailed instructions to use the program are located in the menu option **Help / User's Guide**.

Note: Some windows system can require the **.NET Framework 4** that can be download from microsoft website at <http://www.microsoft.com/en-us/download/default.aspx>.



### WARNING! CAREFULLY READ THE FOLLOWING INSTRUCTIONS AND CONDITION OF USE:

- This loudspeaker is designed exclusively for Professional audio applications. **The product must be installed by qualified personal only.**
- Proel strongly recommends that this loudspeaker cabinet be suspended taking into consideration all current National, Federal, State and Local regulations. Please contact the manufacturer for further information.
- Proel do not accept any liability for damage caused to third parties due to improper installation, lack of maintenance, tampering or improper use of this product, including disregard of acceptable and applicable safety standards.
- During assembly pay attention to the possible risk of crushing. Wear suitable protective clothing. Observe all instructions given on the rigging components and the loudspeaker cabinets. When chain hoists are in operation ensure that there is nobody directly underneath or in the vicinity of the load. Do not under any circumstances climb on the array.

## AIMING and SUSPENDING INSTRUCTIONS

### Fly Bar and accessories

The AX2065 Systems are built to allow the suspension of array with variable shape and dimensions. Thanks to a suspension mechanism designed to be functional, flexible and safe, each system must be suspended or stacked using the **KPTSW215** or **KPTAX2065** fly bar. The loudspeakers are linked together in a column using a series of couplers integrated in the frame of each enclosure. Each system is set up properly both acoustically and mechanically only using the aiming software.

Coupling system in the front does not require any adjustment: using two locking pins, each loudspeaker box is fixed to the previous. The slotted bar in the back is inserted in a U-shaped frame which features a series of numbered holes. Sliding the slotted bar in the U-shaped frame of the next loudspeaker and inserting a locking pin in one of the numbered holes, it is possible to adjust the relative splay angle between two adjacent loudspeakers in the array column.

## KPTSW215 FLY BAR ASSEMBLY SEQUENCE

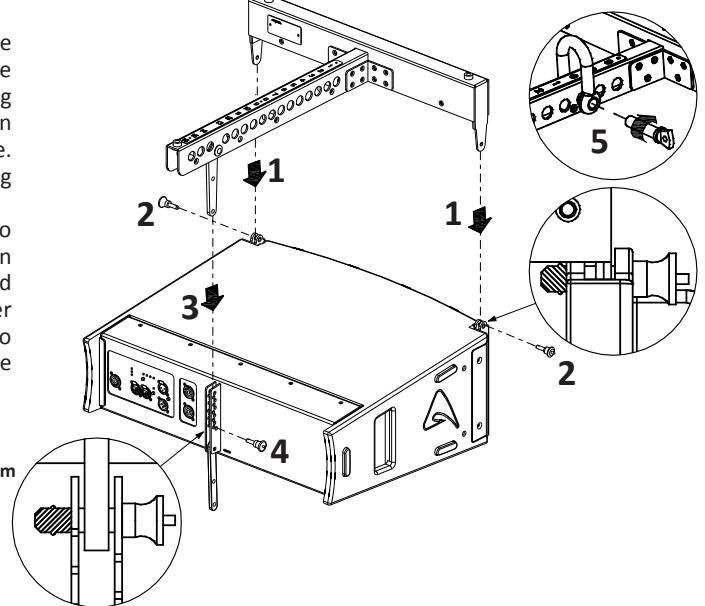

## KPTSW215 FLY BAR AND ACCESSORIES

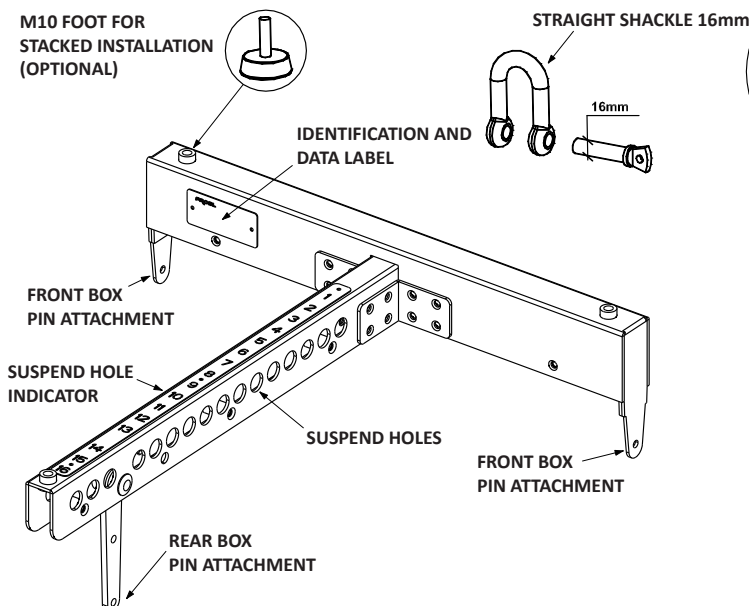

KPTSW215 fly bar maximum capacity is 540 Kg (1190 lbs) with the 0° angle. It can support, with a safety factor of 10:1, up to:

- 8 AX2065A + 8 AX2065P (flybar from 0° to 10°)
- 12 AX2065A (flybar from 0 to 10°)
- 2 SW215AF + 4 AX2065A + 4 AX2065P (flybar at 0°)
- 2 SW215AF + 8 AX2065A (flybar at 0°)
- 6 SW215AF (flybar from 0° to 5°)

KPTSW215 can be used for stacked array, see further on this manual.

KPTAX2065 fly bar maximum capacity is 200 Kg (441 lbs) with the 0° angle. It can support, with a safety factor of 10:1, up to:

- 6 AX2065 active or passive (flybar from 0° to 10°)

KPTAX2065 can NOT be used for stacked array.

**NOTE:** The figures illustrate the KPTWS215 only, KPTAX2065 use is similar with capacity limitations.



## KPTSW215 FLY BAR FOR FLOWN ARRAY

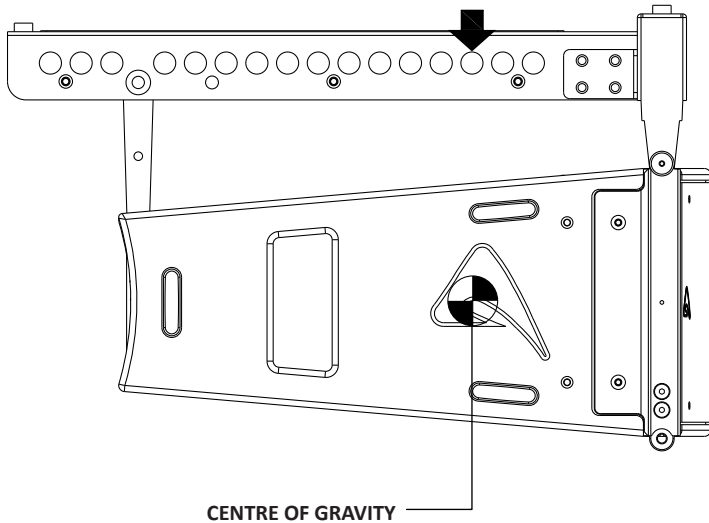

CENTRE OF GRAVITY

## KPTSW215 FLOWN PINPOINT

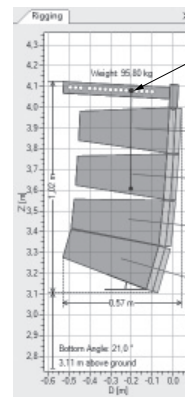

SINGLE PINPOINT FOR STRAIGHT SHACKLE

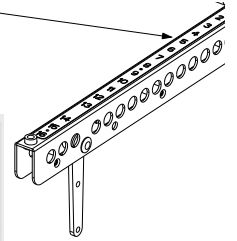
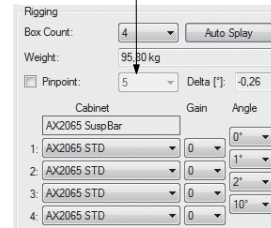

Follow the sequence in the figure for fixing the fly bar at the first box. Usually this is the first step before lifting up the system. Be careful to insert properly all the locking pins (1)(2) and (3)(4) then the shackle (5) in the right holes as specified by the aiming software.

When lifting the system always proceed gradually step by step, paying attention to secure the fly bar to the box (and the box to the other boxes) before pulling up the system: this makes easier to insert properly the locking pins. Also when the system is released down, unlock gradually

the pins. During the lifting be very careful not to let the cables enter the space between one enclosure and the other, as their compression could cut them.

## LOUDSPEAKER SPLAY ANGLES SET UP

### Fly bar suspension and angle setup (centre of gravity)

The figure at the top of this page shows where the normal centre of gravity is with one box or several boxes arranged in a line. Usually the boxes are arranged to make an arc for the best coverage of the audience, so the center of gravity moves backward. The aiming software suggests the ideal suspension pinpoint taking into account this behaviour: fix the straight shackle in this position.

Note that the ideal aiming angle often doesn't correspond to the pinpoint: there is often a little difference between ideal aiming and real aiming and its value is the Delta angle: positive delta angle can be adjusted a little using two ropes, negative delta angle are self adjusted a little because the cables weights on the back of the array. With some experience it's possible to consider preventively these required little adjustments.

During the flown set up you can connect the elements of the array to their cables. We suggest to discharge the weight of the cables from the flying pinpoint by tying them with a textile fibre rope, instead of letting them hang freely: in this way the position of the array will be much more similar to the simulation produced by the software.

### Pin locking and splay angles set up

The figure below shows how to insert correctly the locking pin and how to set up the splay angle between loudspeakers.

### Wind loads

When planning an open-air event it is essential to obtain current weather and wind information. When loudspeaker arrays are flown in an open-air environment, possible wind effects must be taken into account. Wind load produces additional dynamic forces acting on the rigging components and the suspension, which may lead to a dangerous situation. If according to the forecast wind forces higher than 5 bft (29-38 Km/h) are possible, the following actions have to be taken:

- The actual on-site wind speed has to be monitored permanently. Be aware that wind speed typically increases with height above ground.
- Suspension and securing points of the array should be designed to support double the static load in order to withstand any additional dynamic forces.

**WARNING!** Flying loudspeakers overhead at wind forces higher than 6 bft (39-49 Km/h) is not recommended. If the wind force exceeds 7 bft (50-61 Km/h) there is a risk of mechanical damage to the components which may lead to a dangerous situation for persons in the vicinity of the flown array.

- Stop the event and make sure that no person remains in the vicinity of the array.
- Lower and secure the array.

HINGE BAR OF PREVIOUS BOX

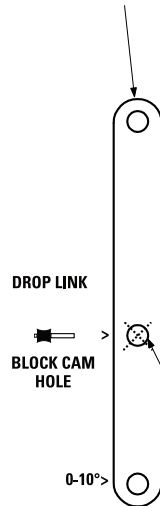

DROP LINK

BLOCK CAM HOLE

0-10°

LOCK THE PIN IN THE HOLE TO OBTAIN THE REQUIRED SPLAY ANGLE.

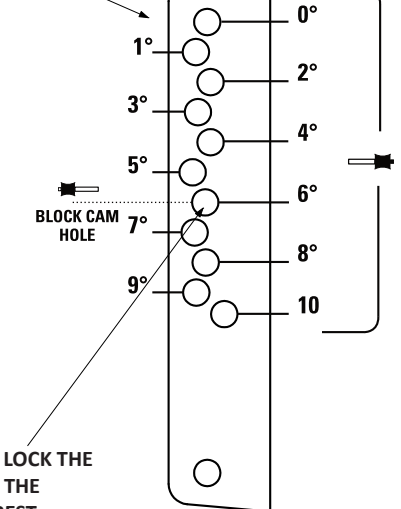

USE THIS HOLE TO LOCK THE HINGE BAR WHEN THE LOUDSPEAKER IS REST

### 95AXM014 LOCKING PIN

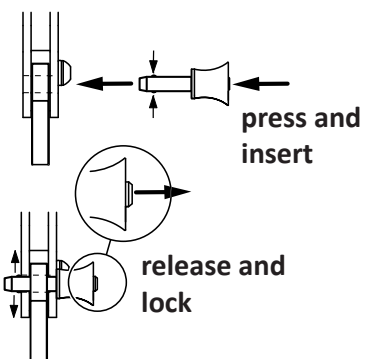

press and insert

release and lock



### Stacked installation (KPTSW215 only)



#### WARNING!

- The ground where the KPTSW215 Fly bar serving as ground support is placed needs to be absolutely stable and compact.
- Adjust the feet so to lie the bar perfectly horizontal.
- Always secure ground stacked setups against movement and possible tipping over.
- A maximum of 4 x AX2065 cabinets with the KPTSW215 Fly bar serving as ground support are allowed to be set up as ground stack.

In the stack configuration you have to use the three optional BOARDACF01 feet and the fly bar must be mounted upside down on the ground.

Coupling system in the front do not require any adjustment: using two locking pins each loudspeaker box is fixed to the previous. The slotted bar in the back is inserted in a U-shaped frame which features a series of numbered holes. Sliding the slotted bar in the U-shaped frame of the next loudspeaker and inserting a locking pin in one of the numbered holes, it is possible to adjust the relative splay angle between two adjacent loudspeakers in the array column.

The optimal splay angles can be simulated using the EASE Focus 2 software.

### KPTSW215 STACKED ARRAY

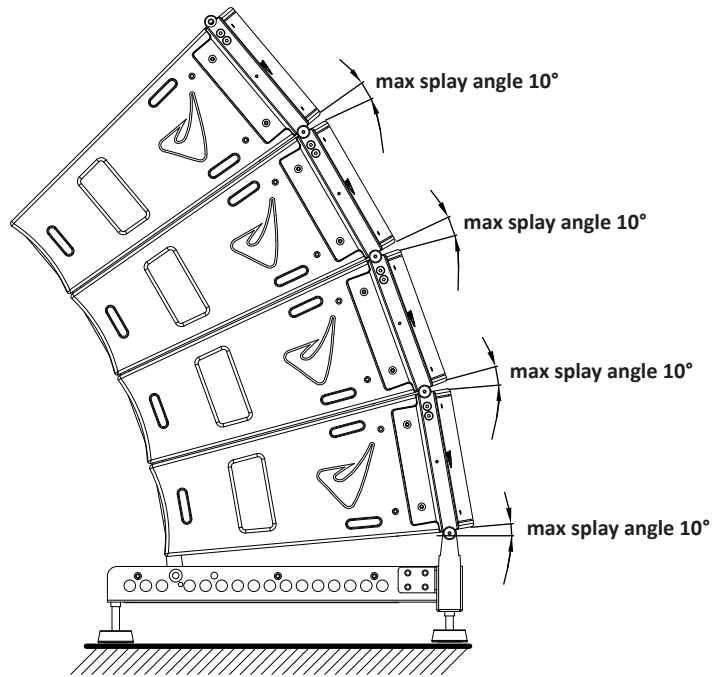

### LIMITED WARRANTY

Proel warrants all materials, workmanship and proper operation of this product for a period of two years from the original date of purchase. If any defects are found in the materials or workmanship or if the product fails to function properly during the applicable warranty period, the owner should inform about these defects the dealer or the distributor, providing receipt or invoice of date of purchase and defect detailed description. This warranty does not extend to damage resulting from improper installation, misuse, neglect or abuse. Proel S.p.A. will verify damage on returned units, and when the unit has been properly used and warranty is still valid, then the unit will be replaced or repaired. Proel S.p.A. is not responsible for any "direct damage" or "indirect damage" caused by product defectiveness.

- This unit package has been submitted to ISTA 1A integrity tests. We suggest you control the unit conditions immediately after unpacking it.
- If any damage is found, immediately advise the dealer. Keep all unit packaging parts to allow inspection.
- Proel is not responsible for any damage that occurs during shipment.
- Products are sold "delivered ex warehouse" and shipment is at charge and risk of the buyer.
- Possible damages to unit should be immediately notified to forwarder. Each complaint for package tampered with should be done within eight days from product receipt.

### SAFETY INSTRUCTIONS

- To reduce the risk, close supervision is necessary when the product is used near children.
- Protect the apparatus from atmospheric agents and keep it away from water, rain and high humidity places.
- This product should be site away from heat sources such as radiators, lamps and any other device that generate heat.
- This product should be located so that its location or position does not interfere with its proper ventilation and heating dissipation.
- Care should be taken so that objects and liquids do not go inside the product.
- The product should be connected to a power supply mains line only of the type described on the operating instructions or as marked on the product. Connect the apparatus to a power supply using only power cord included making always sure it is in good conditions.
- WARNING: The mains plug is used as disconnect device, the disconnect device shall remain readily operable.
- Do not cancel the safety feature assured by means of a polarized line plug (one blade wider than the other) or with a earth connection.
- Make sure that power supply mains line has a proper earth connection.
- Power supply cord should be unplugged from the outlet during strong thunderstorm or when left unused for a long period of time.

### CE CONFORMITY

Proel products comply with directive 2004/108/EC (EMC), as stated in EN 55103-1 and EN 55103-2 standards and with directive 2006/95/CE (LVD), as stated in EN 60065 standard.

PROEL S.p.A. (World Headquarter) - Via alla Ruenia 37/43 - 64027 Sant'Omero (Te) - ITALY  
Tel: +39 0861 81241 Fax: +39 0861 887862 [www.axiomproaudio.com](http://www.axiomproaudio.com)

