

**EMULEX**

# InSpeed<sup>™</sup> Model 370

Embedded Storage Switch



# User's Guide

© 2004 Emulex Corporation. All rights reserved.

Emulex and Vixel are registered trademarks, and InSpeed and FibreSpy are trademarks, of Emulex Corporation. All other brand or product names referenced herein are trademarks or registered trademarks of their respective companies or organizations.

# Table of Contents

<b>Table of Contents .....</b>	<b>ii</b>
<b>Chapter 1: Introduction .....</b>	<b>1</b>
<b>Chapter 2: Switch Installation .....</b>	<b>6</b>
<b>Chapter 3: Switch Management .....</b>	<b>14</b>
<b>Chapter 4: Technical Reference .....</b>	<b>58</b>
<b>Appendixes.....</b>	<b>62</b>
<b>Appendix A: Specifications .....</b>	<b>63</b>
<b>Appendix B: CLI Quick Reference .....</b>	<b>64</b>
<b>Appendix C: Event Messages .....</b>	<b>67</b>
<b>Appendix D: AL_PA Cross References .....</b>	<b>69</b>
<b>Appendix E: Glossary .....</b>	<b>70</b>
<b>Index .....</b>	<b>71</b>

# CHAPTER 1 INTRODUCTION

---

Technical Support .....	1
Overview .....	2
Features .....	2
InSpeed™ Technology .....	3
Switch Applications .....	3

---

---

**Note:** Important safety, electromagnetic compatibility, and regulatory information is contained in the *Safety & Regulatory Guide*. The installation and use of this product must be in accordance with the information provided in that guide.

---

This guide describes how to install and manage the InSpeed™ Model 370 Embedded Storage Switch for embedded applications in storage or tape library systems.

## TECHNICAL SUPPORT

Before contacting Emulex Technical Support, check for solutions in this guide or check with the network administrator.

### Online

---

Contact Emulex Technical Support at [www.emulex.com](http://www.emulex.com). Click the **Support** tab to go to the Product Support page. Under Switch Product Support, click the **switch support E-mail** link to submit service requests.

### Telephone

---

Emulex Technical Support is available between 8:00AM - 5:00PM (PST) Monday through Friday (excluding Emulex Corporation holidays). A Technical Support Engineer will respond within 24 hours (during normal business hours).

Within the United States, call 888-881-6085.

Outside the United States, call 01-1-425-806-4333.

### Software Updates

---

Emulex periodically updates the firmware for switch products. The latest firmware releases are available at [www.emulex.com](http://www.emulex.com). Click the **drivers, software and manuals** link, and select the switch product model under the **Drivers, software and manuals by product model number** section.

## OVERVIEW

The InSpeed Model 370 Embedded Storage Switch is a 20-port, non-blocking switch designed for storage system suppliers who want to improve the reliability, availability, and serviceability (RAS) and performance of their systems.

Enclosed in a 1U, full-rack form factor enclosure, the switch is built around the InSpeed SOC 320 and is controlled by firmware loaded into the on-board Flash.

The switch is designed as a central interconnect following the ANSI FC-AL standard. Devices are connected to the switch through Small Form-factor Pluggable (SFP) transceivers and cables. Each attached node has 1 or 2 Gigabits per second (Gb/s) of Fibre Channel bandwidth. The switch operates at full switching bandwidth that reaches wire speeds of 4 Gb/s per port and up to 80 Gb/s of aggregate bandwidth.

Complete switch configuration and management is available through the intuitive, graphical-based Web Manager interface. A variety of network configurations are easily established using the switch's Port Smart Settings, One-Step Zoning, Automatic Trunking, and Load Balancing features. In addition, the switch features granular change notification management, retained system configuration parameters, and a Command Line Interface (CLI) for advanced users.

## FEATURES

The InSpeed Model 370 Embedded Storage Switch has the following features:

- High Performance Fibre Channel Switching:
  - Wire speed non-blocking Crossbar switch core
  - Single 20-port InSpeed™ SOC 320 ASIC with embedded SERDES
  - Multiple simultaneous conversations between ports
  - Traffic routed directly to destination ports
  - 2 Gb/s or 1 Gb/s performance across all ports
  - Aggregate bandwidth of 80 Gb/s
  - Supports cascades up to 3 switches and up to 126 host and storage devices
  - No complex fabric services or buffers
  - Effortlessly connects to any vendor's fabric
- Patent-pending technology:
  - Fairness and Prioritization—ensures that devices all have guaranteed access, or explicitly have prioritized access, over all other devices in a system.
  - Stealth™ Intelligent Change Manager—delivers maximum stability through automatic elimination of state and change notification system disruptions and unprecedented control of disruptive events.
  - Automatic Trunking—enables fully-multiplied throughput and bandwidth, failover pathing, and dynamic load balancing and device prioritization.
- Advanced diagnostics, performance monitoring, and fault isolation including continuous switch and port monitoring and automatic bypass of problematic or unused ports.
- Port Smart Settings, which are predefined port-level configurations that optimize switch performance and stability.
- One-Step Zoning, including port or AL\_PA-based overlapping/non-overlapping zoning.
- Switch management using the embedded http-based Web server, Command Line Interface (CLI), or Simple Network Management Protocol (SNMP).

- Full-rack, 1U size for easy installation (optional 19" rack-mounting kits available).
- Redundant fans and two hot-swappable, auto-sensing, load sharing, universal power supplies for high availability.
- Fibre Channel ANSI Standards Compliance

## INSPEED™ TECHNOLOGY

InSpeed™ technology is an advanced switching architecture that couples a non-blocking crossbar switch with a unique switch port logic and per-port SERDES. This results in the industry's highest density Fibre Channel switch on a chip (SOC). The port logic is based on Fibre Channel-Arbitrated Loop (FC-AL), an ANSI standard (X3T11) designed to provide shared bandwidth over low-cost media.

This architecture enables the switch's router to send data directly from one port to another, allowing for multiple, simultaneous conversations between ports — effectively multiplying bandwidth. InSpeed™ provides the same performance as complex fabric switches that support FC-SW2.

## SWITCH APPLICATIONS

The InSpeed Model 370 Embedded Storage Switch is ideal for embedded applications in storage or tape library systems, where improvements to the reliability, availability, and serviceability (RAS) and performance of systems is critical. The following sections provide examples of these applications.

### Embedded Root Switch in Disk Storage Systems

In this configuration, the switch connects controllers to the disk shelves. See [Figure 1-1](#) and [Figure 1-2](#) for two examples of this type of application.

Benefits include:

- Improved performance and RAS (Reliability, Availability, and Serviceability) over shared loop architectures.
- Improved isolation and diagnostics down to a shelf level.
- Up to a 250% performance improvement over shared loop-based architectures.
- Requires no design changes to the disk shelves or the storage controllers.

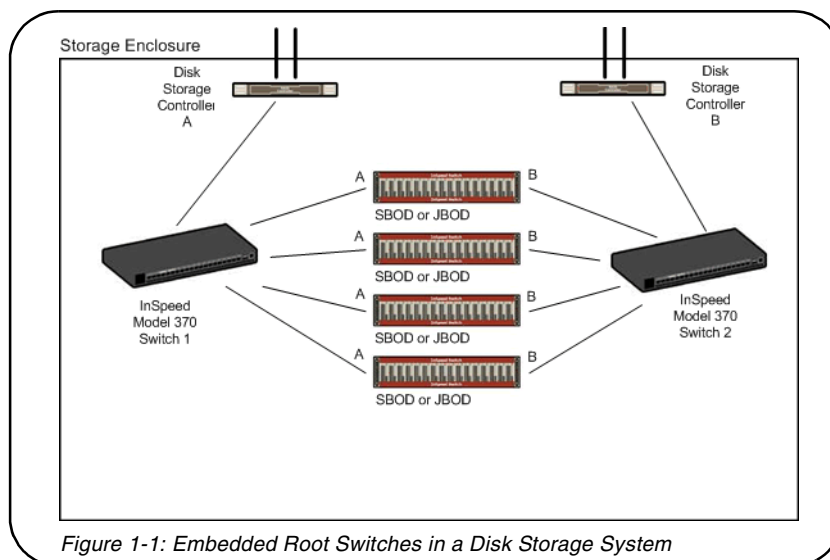
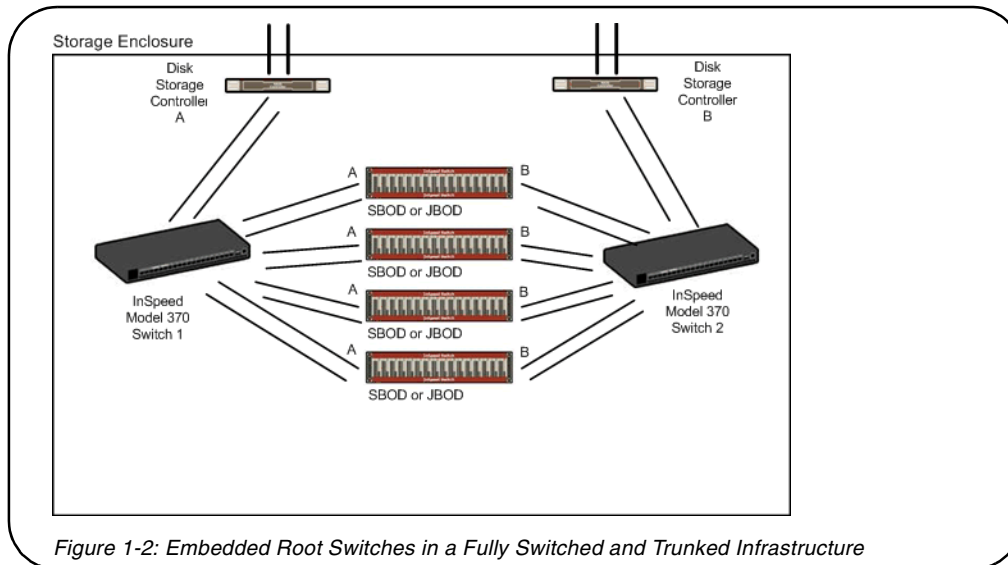

Figure 1-1: Embedded Root Switches in a Disk Storage System



## Embedded Root Switch in Tape Libraries

Another root switch application is to embed a switch attached to multiple tape drives and tape library controllers into a system.

Benefits include:

- Delivers maximum performance and RAS capabilities possible.
- Improved isolation and diagnostics down to the drive level. Enables tape drive/port level fault isolation repair without taking the entire tape library offline.
- Up to a 350% performance improvement over shared loop-based architectures.

Figure 1-3 depicts a sample tape library consolidation configuration.

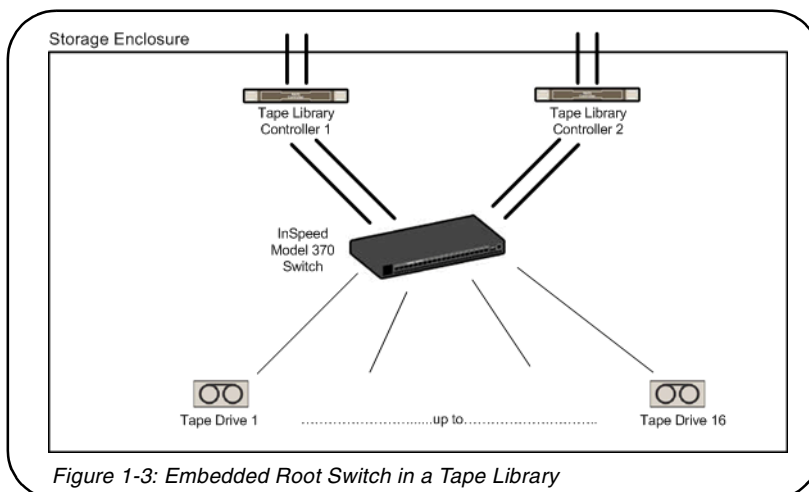

## Embedded Root Switch in Disk & Tape Storage Systems

This application combines an embedded root switch with a disk storage system and a tape library application to provide an integrated disk and tape library solution for the fastest backup and restores possible.

Backups can be performed within the storage system, off the SAN. When this configuration is integrated with the appropriate software, a complete automated storage and backup appliance can be delivered.

Figure 1-4 depicts a sample configuration.

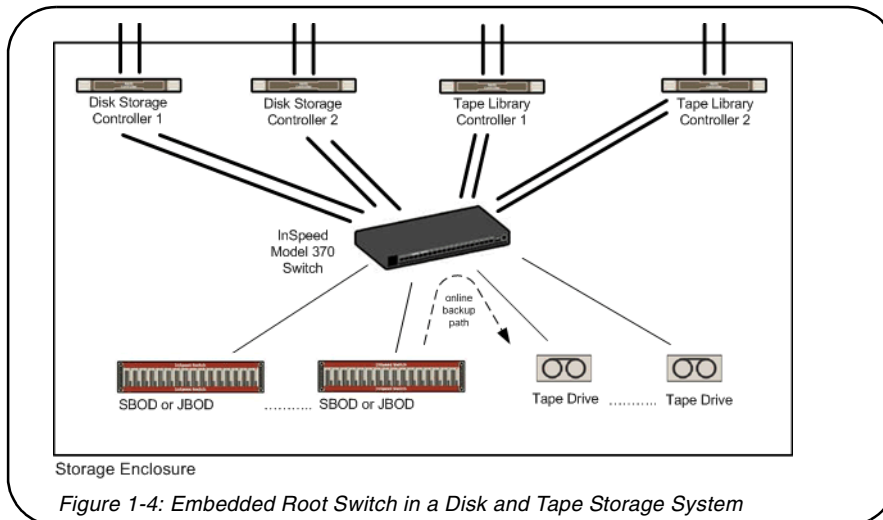

Figure 1-4: Embedded Root Switch in a Disk and Tape Storage System



# CHAPTER 2 SWITCH INSTALLATION

---

Installation Preparation .....	6
Switch Installation .....	7
Switch LEDs .....	8
SFP Compatibility .....	11
Booting the Switch and Attached Devices.....	12
Power Supply/Fan Module Replacement .....	13

---

## INSTALLATION PREPARATION

After receiving the switch, perform the following steps to ensure that the switch and other contents arrived safely.

### To unpack the switch:

1. Inspect the outer shipping container for any damage that may have occurred in shipping. Report any sign of damage to the appropriate shipping agency.
2. Remove the switch and cables from the shipping container; save the shipping container, foam, and antistatic bags—returning the switch in any other container is not advised.

Make sure the following parts are included:

- Switch unit
  - RS-232 null-modem serial cable
  - Power cables (2)
  - Self-adhesive pads (4)
  - Retention clips (2), screws (4), and washers (4) for securing the power cords to the switch.
  - Quick Install Card
  - Product Release Notes
  - Safety and Regulatory Guide
  - Additional documentation, including warranty information and the End User License Agreement.
3. Inspect the switch thoroughly. (If any signs of damage are seen, notify a sales representative and/or the shipping agency.)

## SWITCH INSTALLATION

The switch can be installed in a rack or placed on a desktop.

### Rack Installation

---

Installing the switch in an equipment rack requires an optional rack mount kit (sold separately). There are two kit variations currently available:

- 24-inch Full Rack Mount Kit (Part Number 00651382), which supports equipment rack depths from 24 to 29.75 inches.
- 30-inch Full Rack Mount Kit (Part Number 00651383), which supports equipment rack depths from 30 to 36 inches.

The rack mount kit includes all the necessary hardware and installation instructions for properly installing a switch into an equipment rack. Contact a sales representative for more information or assistance in purchasing a kit.

### UL Guidelines for Mounting Equipment in a Rack

When installing equipment in a rack, give careful consideration to the following factors:

- The operating ambient temperature of rack-mounted equipment must not exceed the maximum rated ambient temperature, which is indicated in this installation guide. (See [“Operating Conditions” on page 63.](#))
- The air flow clearances specified in this installation guide must be maintained within the rack. (See [“Operating Conditions” on page 63.](#))
- The AC supply circuit for rack-mounted equipment must be capable of supplying the total current specified on all the labels of the rack-mounted equipment.
- All AC power supply connections must be properly earthed. To ensure the integrity of the earth connection, special attention must be given to connections that are not directly connected to the branch circuit (for example, power strips).
- The rack-mounting hardware has been carefully selected to properly support the equipment. Any alternate rack-mounting hardware must provide equal or superior support.

### Desktop Installation

---

#### To place the switch on a desktop:

1. Turn the switch upside down so the case bottom is facing up.
2. Install a self-adhesive pad (included) on each corner of the switch bottom approximately 1 inch from each side (prevents surface damage).
3. Turn the switch right-side up so the case bottom is facing down and place the switch on a stable table or platform.

---

**Note:** Important safety, electromagnetic compatibility, and regulatory information is contained in the *Safety & Regulatory Guide*. The installation and use of this product must be in accordance with the information given in that guide.

---

For information on environmental requirements, see [“Operating Conditions” on page 63.](#)

## Installing the Retention Clips (optional)

The switch ships with two, optional retention clips to secure the power cords in each power supply/fan module's power receptacle. Screws (4) and washers (4) are provided for the clips.

### To install the retention clip:

1. Secure the retention clip to the switch by aligning the retention clip with the two screw holes located to the left and the right of the module's power receptacle. The retention clip mounting loops should be facing downward.
2. Place the washer on the screw prior to inserting the screw through the retention clip's mounting loop.
3. Using a screwdriver, tighten the screws to secure the retention clip to the power supply/fan module.

### To insert the power cord with the retention clip in place:

1. Insert the power cord plug into the module's power receptacle. The plug must initially be inserted into the receptacle at an angle to avoid the retention clip.
2. Once the power cord plug is firmly inserted in the module's power receptacle, the retention clip fastens over the end of the power cord plug to secure it in the power receptacle.

### To remove the power cord with the retention clip in place:

Press down on the retention clip while removing the power cord from the module's power receptacle.

## SWITCH LEDs

The switch incorporates four sets of Light-Emitting Diodes (LEDs) to indicate ethernet, switch, port, and power supply/fan module status:

1. Ethernet LEDs – two separate LEDs indicating the network connection status.
2. System LEDs – four separate LEDs indicating the switch's status.
3. Port LEDs – two LEDs per port indicating the port's status.
4. Power Supply/Fan LED – a separate LED for each power supply/fan module indicating the power supply/fan module's status.

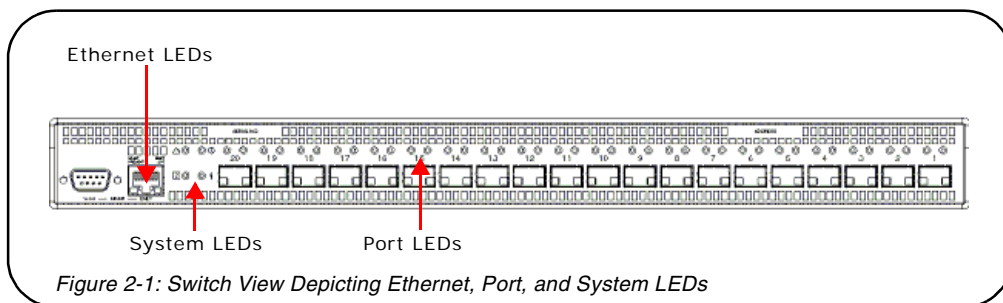

Figure 2-1: Switch View Depicting Ethernet, Port, and System LEDs

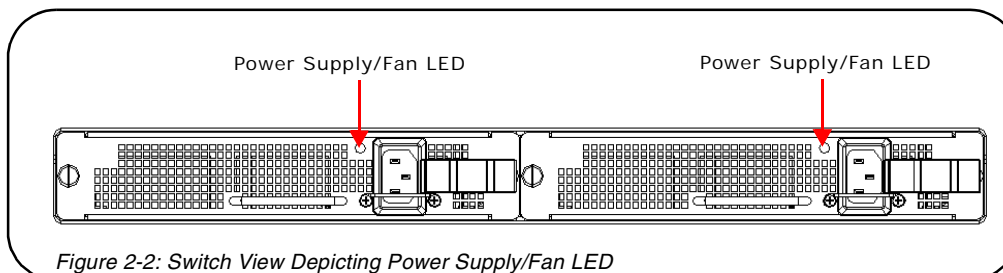
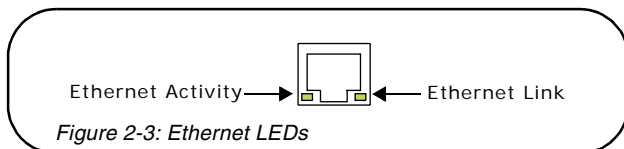

Figure 2-2: Switch View Depicting Power Supply/Fan LED

## Ethernet LEDs

The Ethernet LEDs indicate the network connection status:



Ethernet LEDs	Indication
<b>Ethernet Activity (green LED)</b>	<ul style="list-style-type: none"> <li>When flashing, the ethernet port is receiving data.</li> <li>When flashing rapidly, the traffic level is high.</li> </ul>
<b>Ethernet Link (green LED)</b>	When lit, the switch is connected to an operational ethernet.

## System LEDs

The System LEDs indicate the switch's status, independent of the port LEDs.

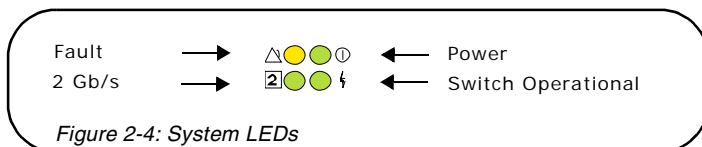

System LEDs	Indication
<b>Fault (yellow LED)</b>	<ul style="list-style-type: none"> <li>When lit, one or more of the ports has failed or the internal temperature has exceeded acceptable levels.</li> <li>When flashing, all ports are operational but another error has occurred. Errors appear in an event log. The level of error severity that will cause flashing to start can be controlled using the <b>config sys fault</b> command in the CLI. The default is level 3, Critical.</li> </ul> <p><b>Note:</b> Whether lit or flashing, the switch will continue to operate. Switch functionality may be impaired depending on the event that triggered the Fault LED. Regardless of the cause, the switch requires immediate attention.</p>
<b>Power (green LED)</b>	When lit, the switch is plugged in and the internal power supplies are functional.
<b>2 Gb/s (green LED)</b>	When lit, the switch is set to operate at a speed of 2 Gb/s. When off, the switch is set to 1 Gb/s.
<b>Switch Operational (green LED)</b>	<ul style="list-style-type: none"> <li>When lit, indicates that the switch has completed initialization for ports with inserted SFPs and that the switch is operational.</li> <li>When flashing, the switch has been configured for multiple zones, and one or more zones are up with at least one zone down.</li> </ul> <p>If no zones (excluding hard zones) are operational, the LED turns off.</p>

## Port LEDs

The Port LEDs indicate the port's status. Each port has two LEDs:

- SFP Status LED
- Port Bypassed LED

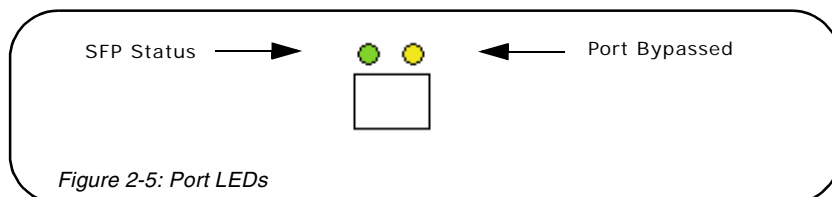

SFP Status LED (green LED)	Port Bypassed LED (yellow LED)	Indication
Off	Off	Normal port operational status when an SFP is not installed.
Off	On or Flashing	The port is bypassed due to a faulty or improperly seated SFP. After fixing this problem, power may need to be cycled before the LED indication will change.
Flashing	Off	Activity. Data is being transferred between the port and device.
On	Off	Normal operation but no activity. Port and device are fully operational.
On	Flashing	Manually bypassed. A port can be manually bypassed using the Web Manager's Bypass Port feature.
On	On	Bypassed. SFP is installed but the port is not receiving a valid signal or is receiving an F8 Failure notification from the attached device.
Flashing	Flashing	Beaconing. This is set manually using the Web Manager or CLI.

## Power Supply/Fan Module LED

The switch uses two power supply/fan modules to guarantee high availability with failover. Each power supply has a separate LED to indicate its condition.

Power Supply/Fan Module LED (green LED)	Indication
On	No faults exist and AC power is supplied to the module.
Off	A power supply or fan fault has occurred in the module.

When a power supply or fan fault occurs, the switch will continue to operate normally as long as the faulty power supply/fan module remains installed in the switch and there are at least two fans operational in each module. If the power supply/fan module is removed from the switch, the switch will continue to operate normally for approximately 20-30 minutes. However, to guarantee continued operation, the malfunctioning module should be immediately replaced to maintain high availability.

**Note:** Keeping spare power supply/fan modules (Part Number 601319) in stock is highly recommended. Contact a sales representative for further information.

## SFP COMPATIBILITY

SFPs are “hot-pluggable” into the switch, which allows host computers, servers, and storage devices to be added dynamically without requiring power removal from the switch or any connected devices.

The switch supports Small Form-Factor Pluggable (SFP) modules that comply with the SFP specification as produced by the MSA consortium and have passed Emulex's qualification testing.

The following manufacturers of 1-2Gb optical, shortwave SFPs are recommended:

- Finisar
- JDS Uniphase

Contact a customer service representative to request the certified part numbers for these vendors.

## Installing an SFP

If the Change Notification on Insertion policy is enabled, plugging an SFP into the switch will automatically send an F7 Initialization notification to indicate the device is ready to begin initialization.

**Caution:** Forcing an SFP into a port may damage the SFP and/or port.

### To insert an SFP:

1. Remove dust covers or plugs from the SFPs, if provided.
2. Slide the SFP into the port, ensuring correct polarity, until the latch clicks into place.

## Removing an SFP

### To extract an SFP:

Determine what kind of extraction mechanism the SFP has and remove the SFP as follows:

*If the SFP has a removal tag, remove the cable from the SFP and then pull the removal tag outward and toward the side of the SFP with the tag.*

*If the SFP has a small plastic slider on the top or bottom, remove the cable from the SFP and then push in the slider and hold while pulling out the SFP.*

*If the SFP has a bale (small metal clasp), remove the cable from the SFP and then unlatch, pivot, and pull the bale.*

## Attaching a Device to the Switch

### To attach a device:

1. Make sure that the device is FC-AL compatible.
2. Attach a cable to the device.
3. Attach the other end of the cable to an SFP.
4. Make sure that the device and switch are operational and set to the same speed.

## BOOTING THE SWITCH AND ATTACHED DEVICES

The following procedure is recommended when booting the switch and attached devices. Before powering on the switch and attached devices, read the Release Notes, included with the switch contents, to determine any modifications that may be required for a specific installation.

### To boot the switch and attached devices:

1. Power on the storage devices (such as disk or tape drives).
2. Insert the plug end of the switch's power cord to a properly grounded power source.
3. Insert the power cord's IEC connector end into the switch's power receptacle.

The switch powers on and runs Power-On Self-Test (POST) diagnostics to verify the fundamental integrity of the switch ports. All switch LEDs turn on (LEDs illuminate). Then, excluding the Ethernet Link, Power Supply/Fan Module, and Power LEDs, the LEDs turn off (LEDs extinguish). Once the switch is operational, the LEDs display current status as described in ["Switch LEDs" on page 8](#).

---

**Note:** The power cord's IEC connector plug serves as the switch's disconnect device. To cycle power to the switch, remove and reconnect the switch's power cord.

---

4. Power on any other switches connected to the SAN.
5. For certain applications, switch configuration must be completed before continuing with the next step. For information regarding switch configuration, see [Chapter 3: Switch Management](#).
6. After all switches have initialized, power on the hosts or storage controllers.

The network initializes.

---

**Note:** FC-AL compatible nodes must perform initialization procedures upon power-up in order to function properly. It is the responsibility of the Fibre Channel driver software on FC-AL nodes to perform this initialization.

---

7. Check all port LEDs.

The network should be fully operational at this point. However, it is appropriate to ensure that proper discovery has taken place and all required devices are participating in the network. Some host bus adapters may provide this level of functionality or it might be resident in the application software on the host operating system.

## POWER SUPPLY/FAN MODULE REPLACEMENT

The InSpeed™ Model 370 Embedded Storage Switch has hot-swappable power supply/fan modules for high availability. A power supply/fan module consists of an individual power supply and a fan bank consisting of three fans.

The switch can run on one functioning power supply/fan module indefinitely, as long as the faulty power supply/fan module remains installed in the switch and there are at least two fans operational in each module's fan bank. If the power supply/fan module is removed from the switch, the switch will continue to operate normally for approximately 20-30 minutes. Non-functional modules should be immediately replaced to maintain high availability.

---

**Note:** Keeping spare power supply/fan modules (Part Number 601319) in stock is highly recommended. Contact a sales representative for further information.

---

### To remove an old power supply/fan module:

1. Have the new power supply/fan module close to the switch for quick insertion. (This step ensures that the procedure takes no longer than necessary—the switch can only operate with one power supply/fan module installed for approximately 20-30 minutes.)
2. Unplug the power cord from the faulty module's power receptacle.

---

**Note:** The alternate power supply/fan module should remain powered on while the faulty module is removed and replaced to guarantee switch availability.

---

3. Slide the safety latch over the power receptacle to expose the thumb screw.
4. Loosen the two thumb screws. No tools are required.
5. Pull the unscrewed power supply/fan module out of the switch's module bay using the module's handle.



**To avoid an electrical hazard, never apply power to the power supply/fan module while the module is removed from the switch.**

### To insert a new power supply/fan module:

1. Align the power supply/fan module with the module bay opening. Ensure that the warning label is facing upwards on the module.
2. Carefully slide the module into the opening. Ensure that the module is seated firmly in the module bay (the module should be flush with the switch's face).
3. Tighten the two thumb screws. No tools are required.

---

**Note:** When using a screwdriver to tighten the thumb screws, ensure that the thumb screws are secure but not overtightened. Overtightening the thumb screws may damage the screws or the module.

---

4. Slide the safety latch over the thumb screw (uncovering the power receptacle).
5. Plug the power cord into the module's module power receptacle.



# CHAPTER 3 SWITCH MANAGEMENT

---

Getting Started.....	15
Managing the Switch.....	20
Monitoring the Switch.....	48

---

This chapter is divided into three sections providing information on how to manage and monitor the switch:

- **Getting Started** – Describes how to configure the network interface, use the Web Manager, and perform a basic initial setup of the switch.
- **Managing the Switch** - Describes how to configure the switch and port settings, manage firmware versions and configuration files, set switch thresholds, and configure One-Step Zoning, Automatic Trunking, and Load Balancing.
- **Monitoring the Switch** – Describes how to view switch information, the event log, port information, and port diagnostics.

The switch incorporates two distinct interfaces for managing and monitoring purposes:

- The Web Manager interface provides an intuitive graphical user interface that enables users to quickly check switch status or modify switch settings in a visual environment.
- The Command Line Interface (CLI) provides flexibility and additional functionality for advanced users.

Both of these interfaces provide nearly identical functionality; however, for the purposes of this guide, the Web Manager interface is used for switch and port configuration unless otherwise noted.

For a list of CLI commands, see [Appendix B: CLI Quick Reference on page 64](#). For additional information on the CLI, see the *Emulex® or InSpeed™ Storage Switch Products' CLI Reference Guide*.

## GETTING STARTED

This section explains how to configure the switch's ethernet network settings prior to using the Web Manager. Once the switch's network settings are configured, use the Web Manager to perform a quick switch setup.

### Configuring the Network Interface

---

Before using the Web Manager, ensure that the switch's ethernet network parameter settings are correct for the network configuration. The switch ships with the following default IP settings:

- IP Address: 192.168.1.129
- Netmask: 255.255.255.0
- Gateway: 192.168.1.1

To adjust these settings to open the Web Manager, connect to the switch using the provided serial interface cable and follow the instructions below.

#### To connect through a serial interface:

1. Attach one end of the included RS-232 null modem cable to the computer's DB-9 serial port and attach the other end to the switch's DB-9 serial port.
2. Open a terminal session through a serial terminal emulation program (such as HyperTerminal®) with the appropriate serial port (for example, COM1) and the following serial port parameters:
  - Bits per second: 19200
  - Data bits: 8
  - Parity: None
  - Stop bits: 1
  - Flow control: None
3. If using HyperTerminal, press ENTER to receive a prompt.  
If using the **tip** command on a UNIX workstation, do the following:
  - a. View the /etc/remote file and create an alias similar to Hardware but with the serial port parameters above. (Suggested name: Switch)
  - b. Use the **tip** command to establish a connection through the created alias, for example **tip switch**. (For more information, see the **tip** command Manual page.)
4. Type the password at the prompt and press ENTER. (The default password is **password**.)
5. From the serial terminal emulation program, type **config network ip** and press ENTER.  
The switch's current IP parameters are displayed with a prompt for entering the IP address.
6. Change the IP address and press ENTER.
7. Use the **mask** and **gateway** commands to change the subnet mask and default gateway respectively.
8. Type **save** and press ENTER.
9. Type **root reset** and press ENTER.
10. Type **y** and press ENTER to reset the switch.
11. Attach the computer to the switch's 10/100 ethernet connector by doing one of the following:
  - Attach an ethernet RJ-45 cross-over cable directly between the computer and the switch.
  - Attach two ethernet RJ-45 twisted pair cables from the computer and the switch into an operational ethernet patch panel or hub.

## Connecting to the Web Manager

The Web Manager displays current port utilization and health, enables easy to use Port Smart Settings and One-Step Zoning, and several additional features discussed later in this chapter.

**Note:** The Web Manager supports Microsoft Internet Explorer for Windows version 5.5 or later and Internet Explorer for Apple version 5.2 or later.

### To connect to the Web Manager:

1. Ensure that the workstation has access to the network on which the switch is connected.
2. Open Microsoft Internet Explorer.
3. In the address bar, type the switch's DNS name or IP address and press ENTER.

## Web Manager Overview

The Web Manager enables users to view and configure switch and port settings using an intuitive, graphical user interface. The main page is the Switch Information page. This page displays general switch status and continually refreshes to display the most current switch status. For more information on the Switch Information page, see [“Switch Information” on page 49](#).

To return to this page at any time, click the **Storage Switch** menu item.

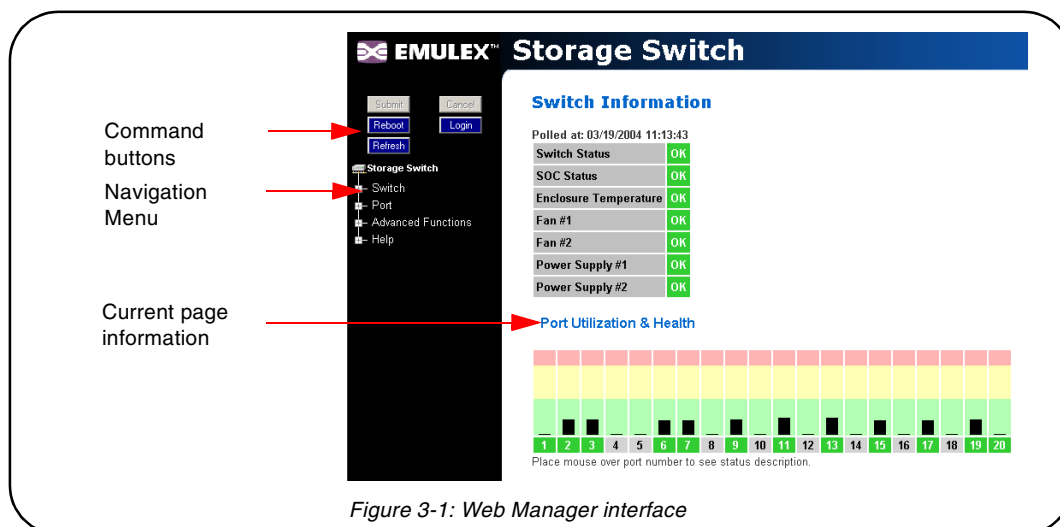

Figure 3-1: Web Manager interface

**Note:** The Web browser's appearance and information depends on the switch's active firmware version and may change without notice in subsequent firmware versions.

The Web Manager interface consists of a series of command buttons, an expandable navigation menu, and the displayed information area. The command buttons and navigation menu are always present on the page.

Command Button	Description
<b>Submit</b>	Saves any changes made to the switch configuration. This button is disabled until a configuration setting is changed or new information is entered. This button appears green to notify the user of a change to the switch configuration. Click this button to accept the configuration change.

Command Button	Description
<b>Cancel</b>	Cancels a request. This button is disabled until a configuration setting is changed or new information is entered. This button appears green to notify the user of a change to the switch configuration. Click this button to cancel the configuration change.
<b>Reboot</b>	Resets the switch.
<b>Login/Logout</b>	Logs in to and out of the switch.
<b>Refresh</b>	Redraws the currently displayed Web page.

The expandable navigation menu provides several options for configuring and monitoring the switch. The menu uses a tree-based navigation structure with a list of menu options and items. Clicking a menu option with a "+" next to it expands the menu option and displays additional menu items. Clicking a menu item displays the selected Web Manager page.

To ensure that the most current information is displayed, use the navigation menu instead of the browser's Back and Next buttons, which usually display cached copies and may not reflect current switch information.

To log out of the Web Manager, click **Logout**, or simply close the browser window.

---

**Note:** The Web Manager will automatically log users out after 15 minutes of inactivity, unless the Switch Information page is currently displayed. The Switch Information page automatically updates to display the most current switch status.

---

## Documentation

The Web Manager's Help menu provides links to online product documentation and firmware downloads.

### To access product documentation and firmware:

1. Click **Help**, and select **Documentation > Product Docs** or **Downloads**.  
The Emulex Web site appears.
2. Click the **drivers, software and manuals** link, and select the switch product model under the **Drivers, software and manuals by product model number** section.

### To view Technical Brief product documentation:

1. Click **Help > Documentation > Technical Briefs**.  
The Emulex Web site appears.
2. Click the **Products** tab, select **fibre channel switches**, and click the **technical briefs** link under Reports/Briefs.

## Initial Switch Setup

---

Once a network connection has been established with the switch and an instance of the Web Manager is open, some basic switch configuration tasks are recommended:

- Log in to the switch.
- Change the switch's password.
- Verify the switch's date and time settings.
- Change the switch's name.

For additional information on Web Manager features and functionality, see [“Managing the Switch” on page 20](#) and [“Monitoring the Switch” on page 48](#).

### Step 1: Log in to the Switch

The switch incorporates a password-level security system to prevent unwanted changes to the current switch configuration. In order to make any changes to the switch, users must be logged in to the switch.

#### To log in to the switch:

1. Click **Login** on any Web Manager page.  
A message box appears confirming the login request.
2. Click **OK**.  
The switch login page appears.
3. Enter the switch's password.  
The default password is "password".
4. Click **Log In**.  
A message page appears while the page is loading. If the page fails to load in the indicated time, click **Continue**.

See [“Logging in to the Switch” on page 21](#) for additional information.

### Step 2: Change the Password

The default password is set at the factory to "password". Change the default password to secure the switch and guarantee that any configuration changes are only performed by registered users.

#### To change the password:

1. Click **Switch > Password**.  
The Switch Password page appears.
2. Enter the new password in the **New Password** text box.  

---

**Note:** The password must be between 6 and 25 characters in length and is case sensitive.

---
3. Enter the new password again in the **Confirm New Password** text box.
4. Click **Submit**.  
A message box appears confirming the change to the switch's configuration.
5. Click **OK**.  
The Password set success message appears confirming that the new password was saved and activated.

See [“Changing the Password” on page 26](#) for additional information.

### Step 3: Verify the Date and Time

During the initial Web Manager session, the date and time for the switch are set based on the host system's current settings.

#### To view the current date and time:

1. Click **Switch > Date & Time**.  
The Switch Date & Time page appears.

#### To set the date and time settings:

1. Enter the new date and time settings in the appropriate fields.
2. Click **Submit**.  
The new date and time appear under Current Date & Time.

#### To synchronize the current date and time settings with the host system:

1. Click **Host Time**.  
The date and time of the current host system appear in the New Date & Time text box.
2. Click **Submit**.  
The new date and time appear under Current Date & Time.

See ["Configuring Date and Time Settings" on page 25](#) for additional information.

### Step 4: Change the Switch Name

While not required, changing the switch's name is recommended for identification and troubleshooting purposes.

#### To change the switch name:

1. Click **Switch > Configuration**.  
The Switch Configuration page appears.
2. Enter the new name in the Name text box.
3. Click **Submit**.  
The new name appears in the Name text box and also appears in the title bar.

---

**Note:** The Web page may have to be refreshed before seeing the name change. Press **CTRL+F5** to refresh the Web browser instance or open a new Web browser instance.

---

See ["Switch Identification" on page 22](#) for additional information.

## MANAGING THE SWITCH

The InSpeed™ Model 370 Embedded Storage Switch provides several options for managing and configuring the switch to meet the needs of the network environment.

This section describes how to log in to the switch, configure switch and port settings, manage firmware and configuration files, and configure One-Step Zoning, Automatic Trunking, and Load Balancing.

### Frequent Switch Configuration Tasks

A list of frequent switch configuration-related tasks is provided below. The list displays the task, the corresponding Web Manager command, and a reference to where more information may be found in this guide.

To...	Click...	In this guide, see...
View switch status	<b>Storage Switch</b>	<a href="#">"Viewing Switch Status" on page 48.</a>
Change general switch configuration	<b>Switch &gt; Configuration</b>	<a href="#">"Configuring the Switch Settings" on page 21.</a>
Change the IP Address	<b>Switch &gt; Configuration</b>	<a href="#">"Network Location" on page 22.</a>
Change the switch speed	<b>Switch &gt; Configuration</b>	<a href="#">"Switch Speed" on page 23.</a>
View the event log	<b>Switch &gt; Event Log</b>	<a href="#">"Viewing the Event Log" on page 51.</a>
Configure traps	<b>Switch &gt; SNMP Traps</b>	<a href="#">"Setting SNMP Traps" on page 24.</a>
Upgrade the firmware	<b>Switch &gt; Files</b>	<a href="#">"Switch Firmware Files" on page 36.</a>
Change the Port Smart Settings	<b>Port &gt; Smart Settings</b>	<a href="#">"Configuring the Port Smart Settings" on page 28.</a>
Configure One-Step Zoning	<b>Advanced Functions &gt; One-Step Zoning</b>	<a href="#">"One-Step Zoning" on page 37.</a>
Configure Automatic Trunking	<b>Advanced Functions &gt; Automatic Trunking</b>	<a href="#">"Automatic Trunking" on page 45.</a>
Configure Load Balancing	<b>Advanced Functions &gt; Load Balancing</b>	<a href="#">"Load Balancing" on page 46.</a>
Reset the switch	<b>Reboot</b>	<a href="#">"Configuring the Switch Settings" on page 21.</a>

For information on viewing switch status and information, see ["Monitoring the Switch" on page 48.](#)

## Logging in to the Switch

The Web Manager requires users to log in to the switch when changes are made to the switch's configuration. Log in is not required for viewing switch information.

### To log in to the switch:

1. Click **Login** on any Web Manager page.  
A message box appears confirming the login request.
2. Click **OK**.  
The Switch Login page appears.

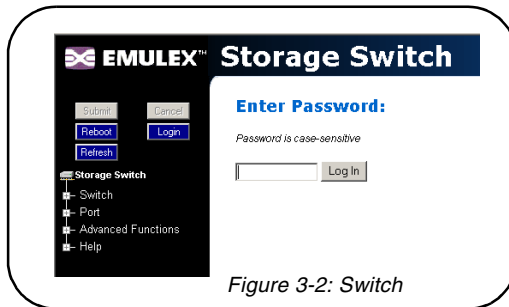

Figure 3-2: Switch

3. Enter the switch's password.

---

**Note:** If you have forgotten the password, contact a customer service representative for assistance.

---

4. Click **Log In**.

A message page appears while the page is loading. If the page fails to load in the indicated time, click **Continue**.

## Configuring the Switch Settings

Several switch configuration settings may be changed to customize the switch to the network environment. To make a change to the current switch configuration, users must be logged in to the switch or know the switch password (the switch prompts users for the password before accepting changes to any configuration settings).

### To change a switch setting:

1. Enter new information or make changes to current settings.
2. Click **Submit**.

The Web Manager page displays the new settings or information.

Changes to certain switch settings require that the switch be reset for those changes to occur. Users must be logged in to the Web Manager to reset the switch.

### To reset the switch:

1. Ensure that any changes to the current switch configuration have been saved.
2. Click **Reboot** on the Web Manager page.

The switch will reset.



## General Switch Settings

The Switch Configuration page displays general settings and switch identification information.

To view the Switch Configuration page, click **Switch > Configuration**.

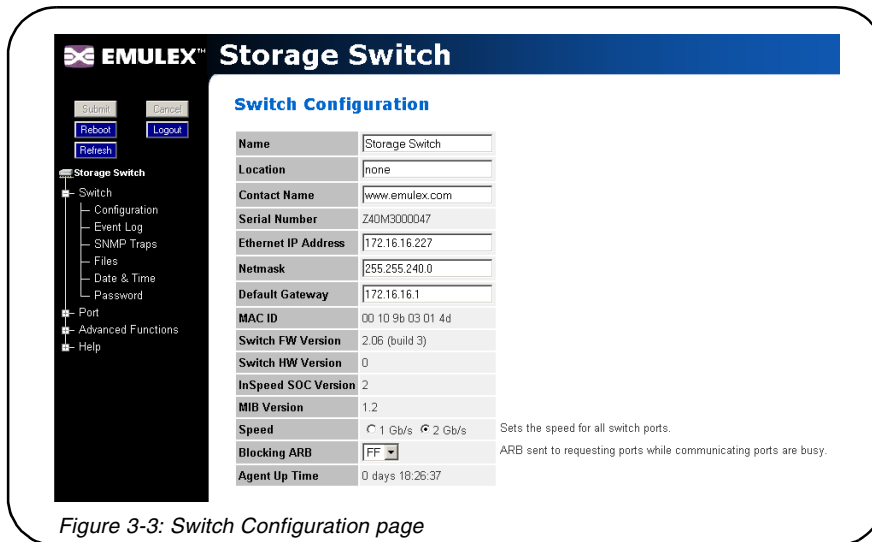

Figure 3-3: Switch Configuration page

## Switch Identification

This section includes general switch identification information.

Setting	Description
<b>Name</b>	The name of the switch.
<b>Location</b>	The location of the switch.
<b>Contact Name</b>	The person or group to contact about the switch.
<b>Serial Number</b>	A unique identification number assigned to each switch at the factory. This setting cannot be configured or modified.

The name, location, and contact name information may be modified for the network environment. The Serial Number setting is factory set and cannot be modified.

### To change the name, location, or contact name:

1. Click **Switch > Configuration**.
2. Enter the new value in the appropriate text box.
3. Click **Submit**.

The Switch Configuration page displays the updated information.

## Network Location

The switch's network location is identified by the IP Address, Netmask, and Gateway fields.

Setting	Description
<b>Ethernet IP Address</b>	The current IP Address for the switch.
<b>Netmask</b>	The current IP Netmask address for the switch.
<b>Default Gateway</b>	The current Gateway address for the switch.

**To change the switch's network location settings:**

1. Click **Switch > Configuration**.
2. Enter the new value in the appropriate text box.
3. Click **Submit**.

The Switch Configuration page displays the updated information.

**Version Information**

The different software and hardware versions include:

Setting	Description
<b>MAC ID</b>	A unique device address (MAC address) assigned to each switch at the factory. This setting cannot be configured or modified.
<b>Switch FW Version</b>	The current firmware loaded onto the switch.
<b>Switch HW Version</b>	The hardware version of the switch. This setting cannot be configured or modified.
<b>SOC Version</b>	The InSpeed™ SOC 320 version that is used in the switch. This setting cannot be configured or modified.
<b>MIB Version</b>	The proprietary Management Information Base version that is supported through SNMP. This setting cannot be configured or modified.

**Switch Speed**

The Switch Speed setting indicates the current speed per port at which the switch is running. All ports operate at the same speed. The default switch speed is set to 2.125 Gb/s.

**To change the switch speed:**

1. Click **Switch > Configuration**.
2. Select the desired speed.

Setting	Description
<b>1 Gb/s</b>	Set switch speed to 1.0625 Gb/s.
<b>2 Gb/s</b>	Set switch speed to 2.125 Gb/s.

3. Click **Submit**.

**Blocking ARB**

When two ports start a communication session, the Blocking ARB is sent to all other ports trying to communicate with those ports until the connection is terminated. The default setting is "FF". If other connected devices use the "FF" setting for another purpose, select another Blocking ARB value (for example, "FB"). Under normal circumstances, this setting does not need to be modified.

**Agent Up Time**

The Agent Up Time field displays the duration of time that the switch has been operational. If the switch is rebooted or power is cycled, this value is reset.

The Agent Up Time field is for display purposes and cannot be configured.

## Setting SNMP Traps

Simple Network Management Protocol (SNMP) uses traps to transmit information to SNMP-based network administration programs. The Switch SNMP Trap Configuration page displays information on the switch's current SNMP trap configuration.

To view the SNMP trap configuration page, click **Switch > SNMP Traps**.

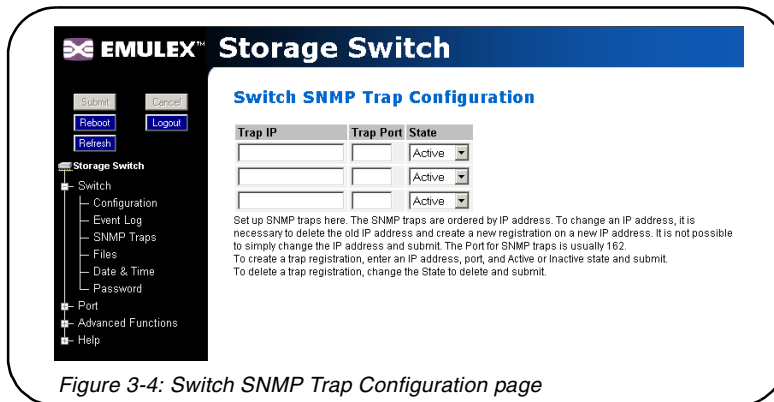

Figure 3-4: Switch SNMP Trap Configuration page

### To configure an SNMP trap:

1. Enter the Trap IP address for the device to which the trap information will be sent.
2. Enter the Trap Port number.  
This value is usually set to "162" for Windows and Apple-based networks.
3. Select the Trap State.

State	Description
<b>Active</b>	The trap sends messages to the host identified in the IP Address selection.
<b>Inactive</b>	The trap is not operational.
<b>Delete</b>	The trap will be deleted from the table once changes are saved.

4. Click **Submit**.

When editing a registered IP address, delete the current IP address and create a new entry for the revised IP address.

## Configuring Date and Time Settings

The Switch Date & Time page displays the switch's current date and time. During the initial Web Manager session, the date and time for the switch are set based on the host system's current settings. If the switch is rebooted or power is cycled, the system clock will reset and the switch's date and time settings will be set to the host system's time settings of the next user to log in to the switch.

### To change the time:

1. Click **Switch > Date & Time**.

The Switch Date & Time page appears.

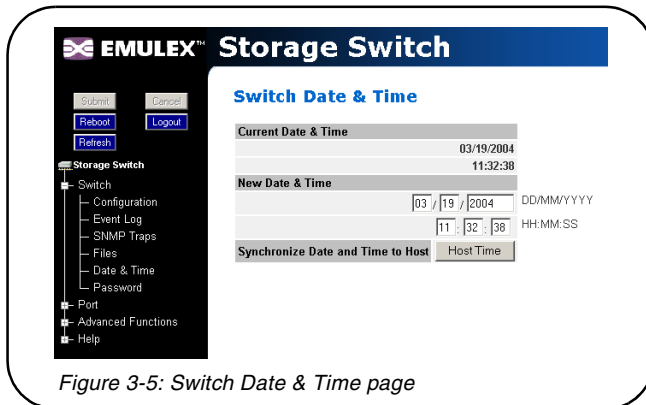

Figure 3-5: Switch Date & Time page

2. Enter the desired date and time in the appropriate fields.
3. Click **Submit**.

### To synchronize time with the host system:

1. Click **Host Time**.

The date and time of the current host system appear in the **New Date & Time** text box.

2. Click **Submit**.

## Changing the Password

The Switch Password page enables users to change the password for modifying the switch's configuration. The same password is used to access both the Web Manager and the CLI.

**Note:** Until the default switch password is changed, any user with knowledge of the default password can make changes to the switch's configuration.

### To change the password:

1. Click **Switch > Password**.

The Switch Password page appears.

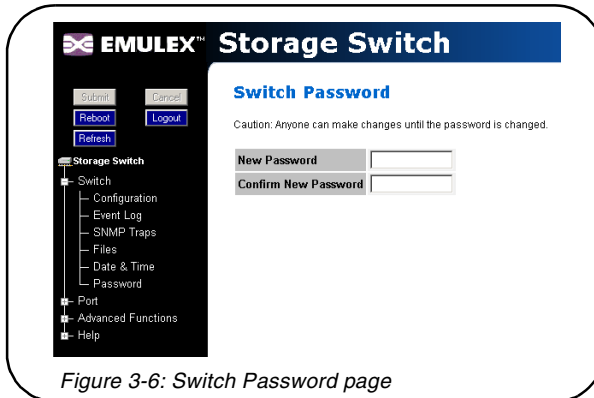

Figure 3-6: Switch Password page

2. Type the new password in the **New Password** text box.

**Note:** The password must be between 6 and 25 characters in length and is case sensitive.

3. Type the password again in the **Confirm New Password** text box.
4. Click **Submit**. If users are not logged in to the switch, a password prompt appears requesting that the current password be entered. Enter the current password to proceed.

A message displays confirming that the password was saved and activated.

## Opening a Telnet Session

Some switch operations may require advanced features currently not found in the Web Manager. These features are available in the Command Line Interface (CLI), which can be accessed through the Web Manager by opening a telnet session to the switch.

### To open a telnet session with the switch:

1. Click **Advanced Functions > Telnet Session**.  
A message box appears confirming the opening of a telnet session to the switch.
2. Click **OK** to proceed.
3. Enter the switch's password and press ENTER.

For additional information on CLI features and functionality, see the *Emulex® or InSpeed™ Storage Switch Products' CLI Reference Guide*.

## Adjusting the Switch Thresholds

The Switch Thresholds page displays a variety of switch threshold settings.

Setting	Description
<b>Ordered Set Error Threshold</b>	The maximum number of OS errors allowed in a 10-second interval before a port is bypassed. Setting this value to "0" returns it to the factory default setting. This setting is activated on the Port Smart Settings page.
<b>CRC Error Threshold</b>	The maximum number of CRC errors allowed in a 10-second interval before a port is bypassed. Setting this value to "0" returns it to the factory default setting. This setting is activated on the Port Smart Settings page.
<b>Bad Zone Recovery Hold Time</b> (measured in centi-seconds)	The amount of time that the switch keeps the ports in bypass mode before attempting to re-insert the ports into the zone. This setting is activated on the Advanced Functions One-Step Zoning page.
<b>Bad Zone Recovery Delay Time</b> (measured in seconds)	The amount of time that the switch waits after a zone goes down before attempting to recover the zone. This setting is activated on the Advanced Functions One-Step Zoning page.
<b>Port Utilization Interval</b> (measured in seconds)	The length of time between readings of the current port's utilization.

**To view the current threshold settings:**

Click **Advanced Functions > Thresholds > Switch**.

The Switch Thresholds page appears.

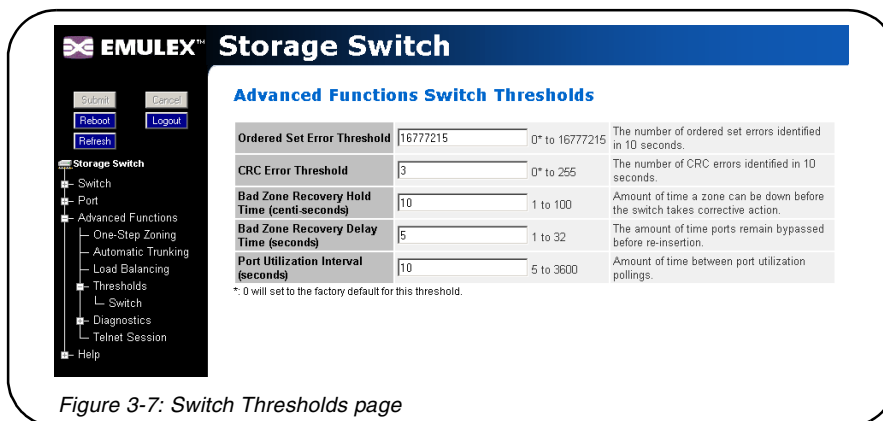

Figure 3-7: Switch Thresholds page

**To change switch thresholds or time intervals:**

1. Enter the new value in the appropriate text box.  
The valid range is displayed next to the text box.
2. Click **Submit**.  
The new value is set.

## Configuring the Port Smart Settings

The Port Smart Settings page displays the current Smart Settings (configuration settings) assigned to each port and enables users to easily create and modify custom Smart Settings.

To view the Port Smart Settings page:

Click **Port > Smart Settings**.

The Port Smart Settings page appears.

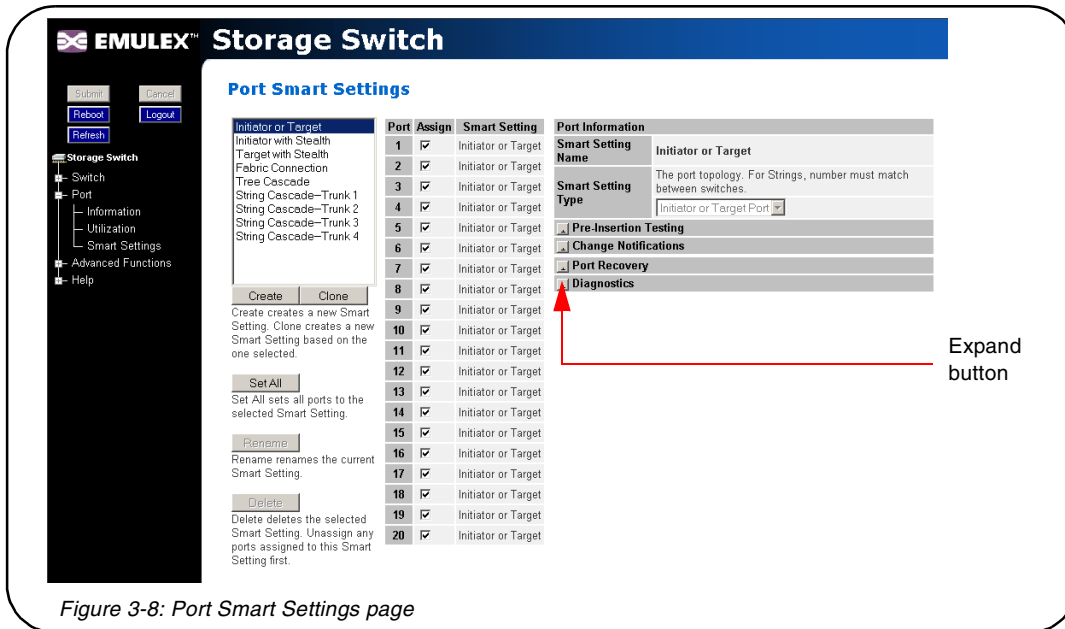

Figure 3-8: Port Smart Settings page

Expanding the optional configuration menus on the right-side of the page by clicking the expand buttons provides additional configuration options.

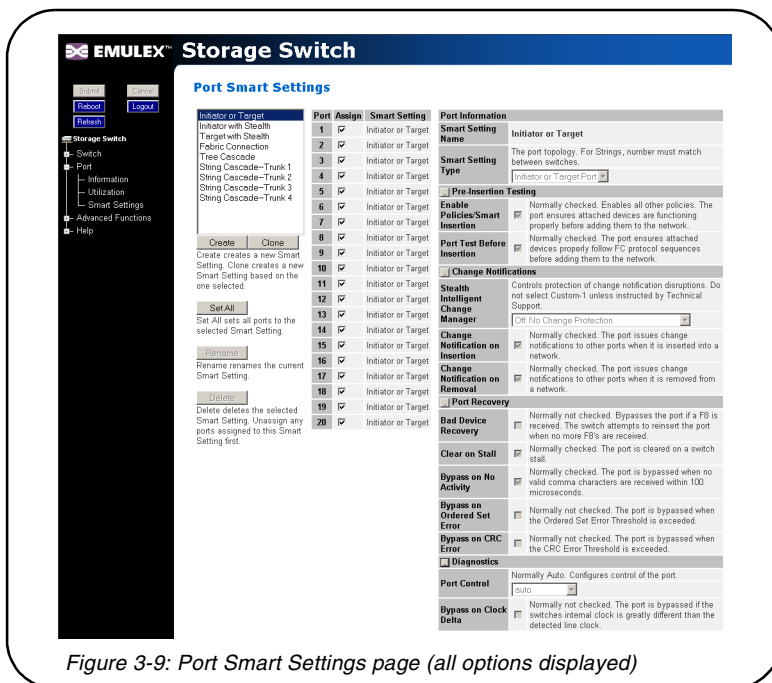

Figure 3-9: Port Smart Settings page (all options displayed)

## Default Smart Settings

There are several default Smart Settings available on the switch. These default Smart Settings were defined by Fibre Channel storage experts to ensure that the switch is optimally configured for performance and stability.

The default Smart Settings cannot be modified or deleted, but these settings can be used as templates for creating custom Smart Settings.

---

**Note:** Changing the Smart Setting of a port may affect the performance or behavior of the system. Depending on the implementation, some Smart Settings are more appropriate than others.

---

### Initiator or Target

This Smart Setting is the default setting for all switch ports from the factory. This setting offers no change protection and all settings are set to their default values. Initiators and targets can be connected to ports that are set to this Smart Setting.

This is the recommended Smart Setting for setups with targets and initiators connected to a single switch.

### Initiator with Stealth

This Smart Setting is used when connecting a host device to the port. When a port is set to this Smart Setting, change notifications are not sent from the initiator to other devices, but change notifications are received by the initiator.

This Smart Setting is appropriate for embedded storage controllers and external Host Bus Adaptors (HBAs) or servers with installed HBAs.

### Target with Stealth

This Smart Setting is used when connecting embedded storage devices, like JBODs, SBODs, tape drives, or external RAID systems (JBODs, SBODs, or tape libraries). When a port is set to this Smart Setting, change notifications are sent to other devices, but change notifications are not received by the target.

### Fabric Connection

This Smart Setting is used when connecting a port to a Fabric switch. Only one connection from the InSpeed Model 370 Embedded Storage Switch to a Fabric switch is valid.

### Tree Cascade

This Smart Setting is used when connecting two or more switches together in a tree configuration. Up to four tree cascades are supported between switches. See [“Cascading Switches” on page 44](#) for additional information.

### String Cascade

This Smart Setting is used when connecting two or more switches together in a string configuration. Up to four string cascades are supported between two switches. See [“Cascading Switches” on page 44](#) for additional information.

Before selecting a cascade option, consider the following:

- Cascade ports of like number should be connected together. For example, connect port 1 of Switch A to port 1 of Switch B, connect port 2 of Switch B to port 2 of Switch C, and so on.
- Cascade port numbers must be lower than non-cascade port numbers (for example, Initiator or Target ports). Therefore, select cascade types before selecting these non-cascade types.
- A maximum of three switches may be connected using string cascades.



- When configuring multiple switches with a single cascade, use alternating ports. For example, connect the second switch using ports 1 and the third using ports 2 as shown in [Figure 3-10](#).

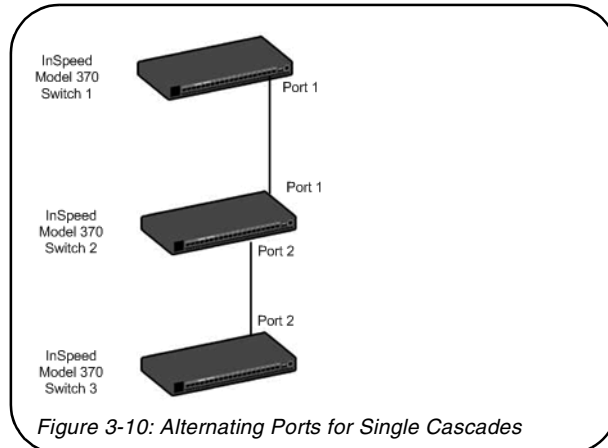

#### To assign a Smart Setting to one or more ports:

1. Select the appropriate Smart Setting from the list box.
2. From the list of port numbers, select the ports that will use the selected Smart Setting under the Assign heading.
3. Once completed, click **Submit** to save the settings.

#### To set all ports to the currently selected Smart Setting:

1. Select the desired Smart Setting from the list box.
2. Click **Set All**.
3. Click **Submit** to save the new settings.

### Creating Custom Smart Settings

In addition to the default Smart Settings, users can create custom Smart Settings for use in a specific network environment.

#### To create a custom Smart Setting:

1. Click **Create**.

A text box appears prompting for the name of the new Smart Setting.

---

**Note:** The Create function always uses the Initiator or Target Smart Setting as the base setting from which to configure a custom Smart Setting.

---

2. Enter the new Smart Setting name.

A name may consist of up to 28 alphanumeric characters and cannot contain spaces (use underscores for spaces in names).

3. Click **OK**.

The new Smart Setting is added to the list box.

4. Click **Submit** to save the new Smart Setting.

**To create a custom Smart Setting based on an existing Smart Setting:**

1. Select a Smart Setting from the list box that most closely matches the port settings that the new Smart Setting should have.
2. Click **Clone**.
3. Enter the new Smart Setting name.  
A name may consist of up to 28 alphanumeric characters and cannot contain spaces (use underscores for spaces in names).
4. Click **OK**.  
The new Smart Setting is added to the list box.
5. Click **Submit** to save the new Smart Setting.

**To modify a custom Smart Setting:**

1. Ensure that the custom Smart Setting is not currently assigned to a port before making any changes.
2. Select the custom Smart Setting in the list box.
3. Select the new settings.
4. Click **Submit** to save the new settings.

**To rename a custom Smart Setting:**

1. Select the desired Smart Setting from the list box.
2. Click **Rename**.
3. Enter the new Smart Setting name.  
A name may consist of up to 28 alphanumeric characters and cannot contain spaces (use underscores for spaces in names).
4. Click **OK**.  
The new Smart Setting name appears in the list box.
5. Click **Submit** to save the change.

**To delete a custom Smart Setting:**

1. Ensure that the custom Smart Setting is not selected or currently in use.
2. Select the custom Smart Setting in the list box.
3. Click **Delete**.
4. Click **Submit** to save the settings.

## Smart Setting Assignments

The Smart Settings are based on several port settings and policies grouped into the following categories:

- Port Information
- Pre-Insertion Testing
- Change Notifications
- Port Recovery
- Diagnostics

These settings can be adjusted on custom Smart Settings; however, these settings are fixed on the default Smart Settings.

### Port Information

The following settings are available.

Setting	Description
<b>Smart Setting Name</b>	Displays the name of the Smart Setting. The Smart Setting name will automatically appear in the text box when selected in the scroll menu.
<b>Smart Setting Type</b>	The topology among switches for a port. Options include: <ul style="list-style-type: none"> <li>• Initiator or Target Port – the default setting. Should be used when there are no links between switches.</li> <li>• Tree Cascade – designates the port as a tree cascade port. Use this setting when connecting multiple switches together in a tree cascade configuration. Under most conditions, this setting will result in acceptable performance.</li> <li>• String Cascade 1 through String Cascade 4 – designates the string cascade to which a port is assigned. String cascades maintain fairness when two or more InSpeed-based storage switches are serially cascaded. Switch performance may be lower when compared to a tree cascade configuration.</li> </ul>

### Pre-Insertion Testing

The following settings are available.

Setting	Description
<b>Enable Policies/Smart Insertion</b>	This policy is the default operating mode for all ports and determines what the switch looks for prior to allowing a port to insert into a zone. When the policy is enabled, an external device is sent an F7 Initialization notification by the switch until an F7 Initialization notification is received from the device. Once an F7 Initialization notification is received, the port is inserted in the zone. This policy takes precedence over all other policies. When this policy is disabled, no additional policies are operational, and as long as a port transmits a signal of the correct frequency and amplitude, the port will be allowed in the zone.

Setting	Description
<b>Port Test Before Insertion</b>	This policy ensures that a device on a port is a valid, standards-compliant participant before allowing the device to be inserted into a zone. The device must meet all of the FC-AL requirements along with going through a complete change notification cycle. During the change notification cycle, the device becomes the Initialization Master (IM) and goes through the change notification phases. Once the change notification cycle is complete, the device can be inserted. This process ensures that a bad device is not allowed into the zone.

## Change Notifications

The following settings are available.

Setting	Description
<b>Stealth Intelligent Change Manager</b>	Stealth Intelligent Change Manager provides stability and control over change notification disruptions on a port basis. Options include: <ul style="list-style-type: none"> <li>• Off: No Change Protection – no Stealth Intelligent Change Manager control.</li> <li>• Initiator: Only Receive Changes – devices attached to the port can receive change notifications but will not propagate change notifications generated by that port to other ports.</li> <li>• Target: Only Send Changes – propagates change notifications generated by the port to other ports but will not allow devices attached to the port to receive change notifications from other ports.</li> <li>• Switch-Switch: Send and Receive Changes – allows change notifications to propagate between switches.</li> <li>• Custom-1 – <b>Note:</b> This setting should not be used unless directed to do so by a customer service representative.</li> </ul>
<b>Change Notification on Insertion</b>	The switch normally operates under the condition that when a device is inserted onto the network, a change notification is generated. However, this condition is not always true when connecting hubs or switches together. In some instances, it is possible to connect two zones together without the zones realizing that multiple AL_PAs exist with the same values. When this policy is enabled, the switch always generates a change notification to ensure that the proper system updates are performed. However, when a device is removed (for example, an initiator or target), the removal does not generate a change notification and there are no system updates performed.
<b>Change Notification on Removal</b>	This policy is similar to the Change Notification on Insertion policy, except for the change notification being sent when a device is removed rather than inserted. When this policy is enabled, the switch always generates a change notification to ensure that the proper system updates are performed.

## Port Recovery

The following settings are available.

Setting	Description
<b>Bad Device Recovery</b>	<p>When a port is already inserted into a zone, the port transforms F8 Failure notifications into F7 Initialization notifications. When this occurs, the port is bypassed and F7 Initialization notifications are allowed in the zone. Once the initialization is complete, the Bad Zone Recovery Policy is operational and prevents a port that continues to transmit F8 Failure notifications from inserting into the zone.</p> <p><b>Note:</b> If this policy is disabled while the Bad Zone Recovery policy is enabled, a zone that does go down will still allow the Bad Zone Recovery policy to reset the zone and allow ports to be reinserted.</p> <p>When enabled, this policy prevents devices that send F8 Failure notifications from inserting into a zone. The ability to remove devices that generate F8 Failure notifications automatically and instantaneously guarantees continual system operation.</p> <p>When disabled, this policy allows devices that send F8 Failure notifications to insert into a zone and does not consider F8 Failure notifications when determining whether to insert a device or not.</p>
<b>Clear on Stall</b>	<p>In situations where the switch is operating in switching mode, some devices may fall into an operating mode where the device has opened a target but has not released the connection to the target. When this policy is enabled, the switch can detect this condition and automatically recover when this situation arises.</p>
<b>Bypass on No Activity</b>	<p>The switch detects the amount of time a data stream has gone without receiving a comma. The time setting is set to 100 (.001 seconds). When this policy is enabled, the switch bypasses the disruptive port when the threshold is exceeded.</p>
<b>Bypass on Ordered Set Error</b>	<p>Ordered Set (OS) errors are detected and counted for each individual port. When this policy is enabled, a port is bypassed when its OS count exceeds the threshold setting. The threshold setting is based on the number of ordered set errors identified in 10 seconds.</p> <p><b>Note:</b> This threshold setting can be adjusted on the Web Manager's Advanced Functions Switch Thresholds page.</p>
<b>Bypass on CRC Error</b>	<p>Cyclic Redundancy Check (CRC) errors are detected and counted for each individual port. When this policy is enabled, a port is bypassed when its CRC count exceeds the threshold setting. The threshold setting is based on the number of CRC errors identified in 10 seconds.</p> <p>User intervention is required to return the port into the zone. Recovery methods include replacing the defective component, cycling power to the device on the port, removing and reinserting the bypassed port, or cycling power to the switch.</p> <p><b>Note:</b> This threshold setting can be adjusted on the Web Manager's Advanced Functions Switch Thresholds page.</p>

## Diagnostics

The following settings are available.

Setting	Description
<b>Port Control</b>	<p>The method for controlling a port. Options include:</p> <ul style="list-style-type: none"> <li>• auto – the default setting. The switch will automatically insert a port based on policy settings. This prevents the insertion of incompatible ports, which may cause disruption.</li> <li>• bypass – removes a port from the network. Use this mode to keep a device out of an initialization cycle when troubleshooting.</li> <li>• extLoopback – removes a port from the network and routes the port's receive signal back through the port's transmitter. Use this mode to isolate a specific zone for troubleshooting or to test a transceiver's circuitry and attached media from the node end.</li> <li>• insert – allows ports whose transceivers cannot derive a valid clock or "K" character (Ordered Set) to join a zone. Use this mode cautiously – devices without valid characters may put bad data into a zone, causing the zone to go down.</li> </ul>
<b>Bypass on Clock Delta</b>	<p>The switch determines the relative frequency of the signal being received by a port to the internal switch clock. The result of this test allows the determination of how far apart in frequency the switch's clock is in relation to the clock of the received signal – the clock delta. If the clock delta exceeds a set threshold, the switch is notified and the port may be bypassed if necessary. Typically, clock drift is slow enough to allow the removal and replacement of a defective part before the defective part begins to affect system performance.</p>

## Managing Firmware and Configuration Files

The Switch Files page displays information on the switch's firmware and configuration files.

To view the firmware and configuration files, click **Switch > Files**.

The Switch Files page appears.

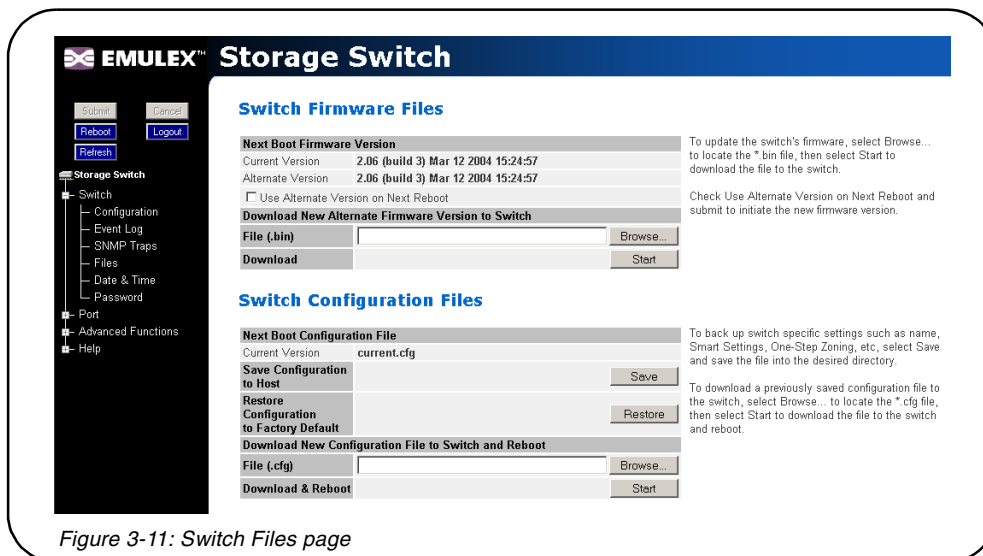

Figure 3-11: Switch Files page

## Switch Firmware Files

This section displays the current and alternate firmware versions, enables users to select which firmware version to run the next time the switch is reset, and provides a means to load new firmware on the switch.

### To check for new firmware:

1. Click **Help** and select **Downloads**.  
The Emulex Web site appears.
2. Click the **drivers, software and manuals** link, and select the switch product model under the **Drivers, software and manuals by product model number** section.

### To load new firmware on the switch:

1. Under Download New Alternate Firmware Version to Switch, enter the directory path and the specific file name in the text box, or click **Browse** to navigate to and select the appropriate file on the host system. The file must have a .bin extension.
2. Click **Start** to load the new firmware image.  
Once the firmware has been installed, the new firmware should appear as the Alternate Version firmware.
3. Under Next Boot Firmware Version, ensure that the **Use Alternate Version on Next Reboot** option is selected. The alternate firmware version currently displayed will be loaded on the next boot cycle.
4. Click **Reboot** to reset the switch using the selected firmware.

---

**Note:** When loading new firmware on the switch, clear the Web browser's cache and files to ensure the removal of the older firmware information. In Internet Explorer, use the key combination **CTRL+F5**, or select **Tools > Internet Options** and click **Delete Files**.

---

### To select the alternate firmware version for the next boot:

1. Under Next Boot Firmware Version, select **Use Alternate Version on Next Reboot**. The alternate firmware version currently displayed will be loaded on the next boot cycle.
2. Click **Submit**.
3. Click **Reboot** to reset the switch.

## Switch Configuration Files

Switch configuration settings (for example, zoning or Port Smart Settings) can be saved for backup purposes or for loading the same configuration on multiple switches.

### To save the current configuration:

1. Click **Save** to save the current switch configuration.
2. Click **OK** on the File Download dialog box.
3. Enter the directory path and file name, being sure to use a .cfg extension.
4. Click **Save**.

### To load a saved configuration:

1. Under Download New Configuration File to Switch and Reboot, enter the directory path to the .cfg file in the text box, or use the **Browse** button to navigate to the appropriate file.
2. In the Choose File dialog box, navigate to and select the appropriate file and click **OK**.
3. Click **Start**.  
A message box appears confirming the download and required switch reset.
4. Click **OK** to proceed.

## Restoring the Factory Default Settings

If necessary, the switch settings can be reset to their factory default values; however, the network configuration and port type settings are retained.

### To restore the factory default configuration:

1. From the Restore Configuration to Factory Default section, click **Restore**.  
A message box appears confirming the request.
2. Click **OK** to restore the factory default configuration and reset the switch.

## One-Step Zoning

Zoning allows ports to be divided into multiple virtual zones (or work groups), similar to Virtual Local Area Networking (VLAN). By separating activity on the network, zoning also eliminates change notification propagation (change notifications that occur within one zone cannot propagate to other zones.)

Use zoning to:

- Separate different operating system environments.
- Temporarily block or grant access during backup or other tasks.
- Consolidate equipment logically.
- Designate closed user groups for increased security.
- Separate test or maintenance areas from production areas.

Zone configuration settings are available on the Web Manager's One-Step Zoning page. The page is arranged as a grid of check boxes for placing ports in appropriate zones. Ports are listed across the top of the grid. Zones are listed down the left side. Similar to other Web Manager pages, the port color represents the current port status.

### To view the One-Step Zoning page:

Click **Advanced Functions > One-Step Zoning**.

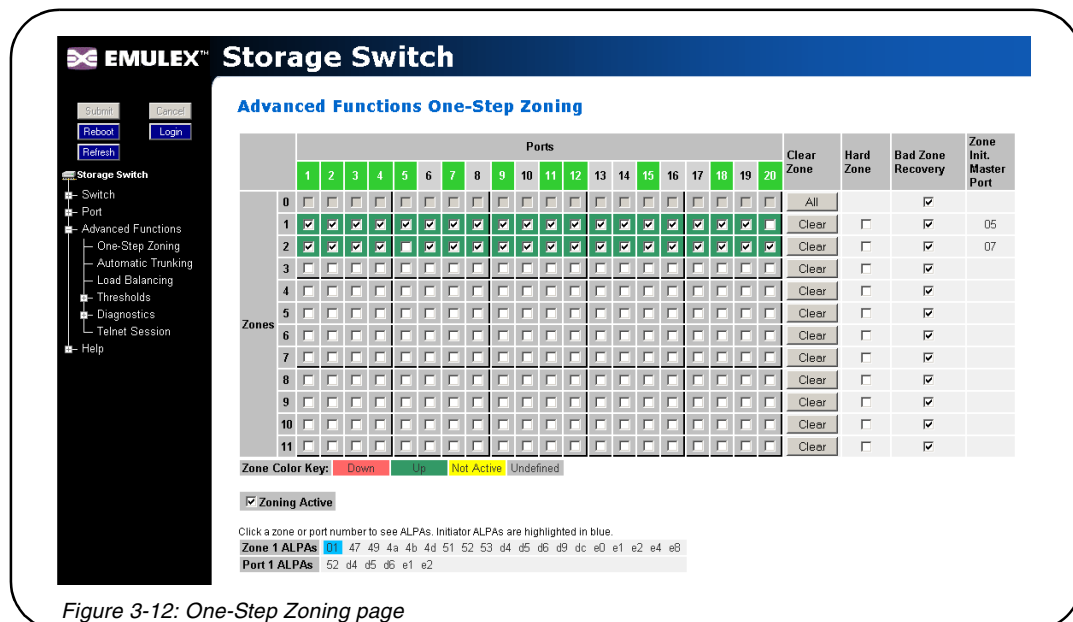

Figure 3-12: One-Step Zoning page



The switch is capable of up to twelve zones. Initially, all ports reside in Zone 0. However, a port will clear from Zone 0 whenever it is selected and placed in another zone.

The color of each zone indicates its status. See the descriptions in the following table:

Color	Description
<b>Down (red)</b>	One or more ports have been selected, zoning has been activated, but hardware has caused a failure.
<b>Up (green)</b>	Ports have been selected, zoning has been activated, and the FC-AL circuit is operational.
<b>Not Active (yellow)</b>	Ports have been selected but zoning has not been activated.
<b>Undefined (gray)</b>	No ports have been selected.

The Zone Initialization Master field displays the port number of the port that is currently assigned as the master for that particular zone. The Initialization Master is responsible for starting the change notification process in each zone.

**To add ports to a zone:**

1. Select the appropriate check boxes to place ports into zones.
2. Click **Submit**.

**To activate zoning:**

1. Select the **Zoning Active** check box near the bottom of the page.

**Caution:** Clearing the Zoning Active check box will deactivate all zones, which may degrade system performance or compromise security.

2. Click **Submit**.

**To remove a port from a zone:**

1. Clear the appropriate check box.
2. Click **Submit**.

**To remove all ports from a zone:**

1. Click **Clear** at the end of the row of check boxes for the appropriate zone.
2. Click **Submit**.

**To remove all zones:**

1. Click **All** under the Clear Zone heading.
2. Click **Submit**.

## Single-Switch Zoning

The simplest zoning configuration is to place devices into separate (non-overlapping) zones. Only the devices within each zone can communicate with one another. Examples of these configurations are shown in [Figure 3-13](#), [Figure 3-14](#), and [Figure 3-15](#).

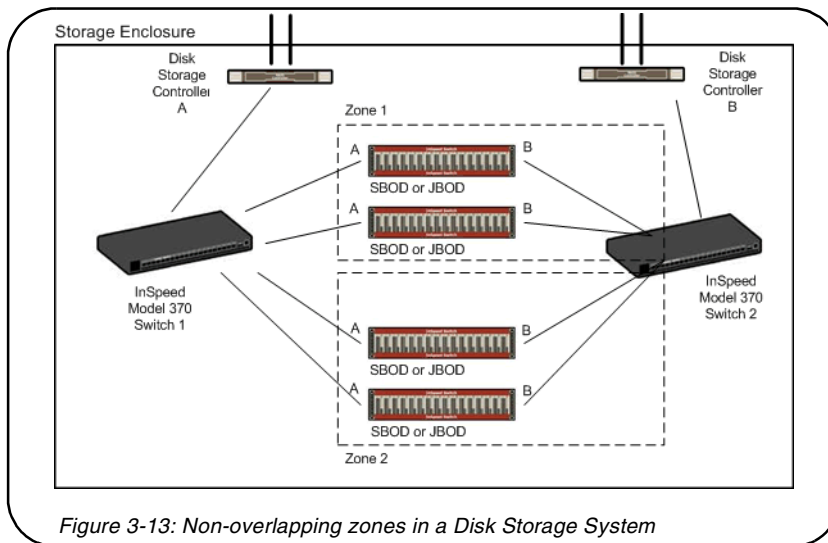

Figure 3-13: Non-overlapping zones in a Disk Storage System

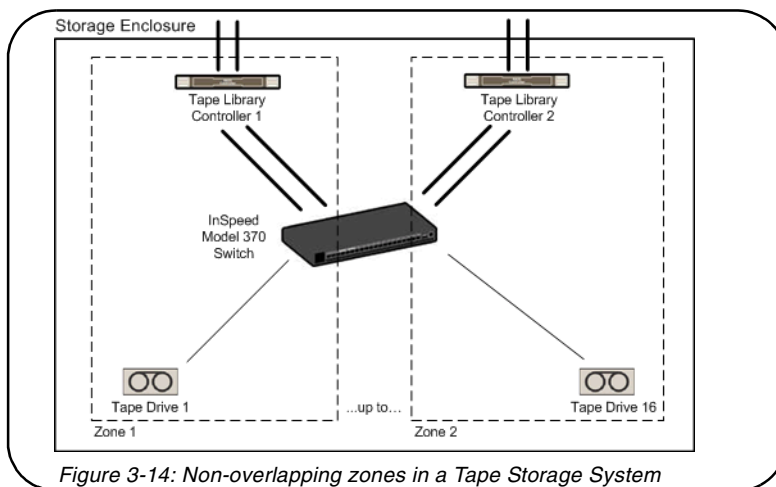
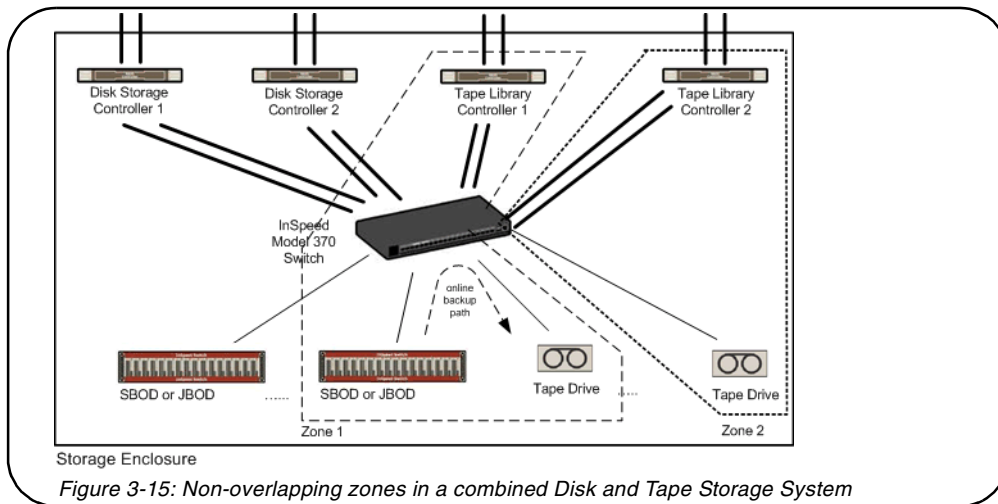
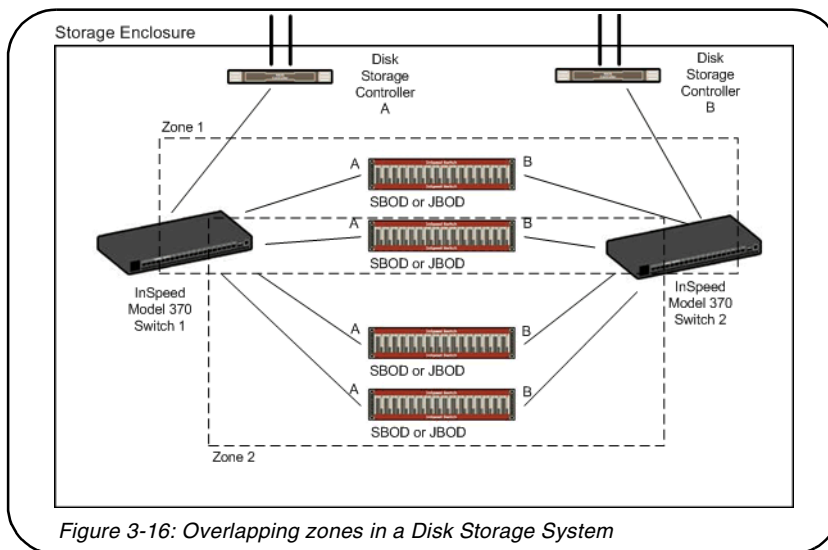

Figure 3-14: Non-overlapping zones in a Tape Storage System



### Adding Devices to Multiple Zones

Another zoning configuration enables users to place devices in more than one zone (overlapping zones). Overlapping zoning enables devices to be shared between hosts, which is important for backup and recovery purposes. [Figure 3-16](#) and [Figure 3-17](#) demonstrate this zoning configuration.



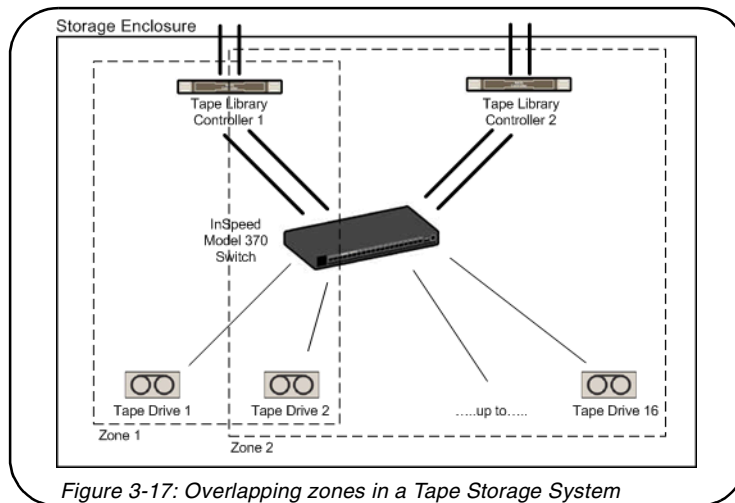

Figure 3-17: Overlapping zones in a Tape Storage System

**To add storage devices to multiple zones:**

1. Select the appropriate zones for each port.
2. Ensure that the Zoning Active check box is selected.
3. Click **Submit**.

**Multiple Switch Zoning**

While not common in embedded storage systems, zoning can also be configured across multiple switches. The procedure is the same as on a single switch; however, multiple-switch zoning requires some coordination between the switches.

**Note:** To ensure zone integrity when configuring multiple switch zoning, you must implement AL\_PA zoning through the Command Line Interface (CLI). See “AL\_PA Zoning” on page 43 for additional information.

**To configure multiple-switch zoning, do the following for each switch:**

1. Plan which ports should belong in each zone.
2. From the One-Step Zoning page, select the appropriate ports for each zone.
3. Ensure that the Zoning Active check box is selected for both switches.

**Caution:** Clearing the **Zoning Active** check box will deactivate all zones, which may degrade system performance or compromise security.

4. After making changes, click **Submit**.

## Connecting Ports Through Hard Zoning

A Hard Zone can be used to add a separate 126 AL\_PAs that operate in isolation from any other zone. A Hard Zone disables switching functionality and creates a shared connection between the ports in a zone topology, splitting the switch into multiple unique FC-AL zones. When Hard Zoning is enabled, all switch zones must be Hard Zones. A combination of Hard Zones and regular zones on a single switch is not allowed.

**Caution:** Do not set a Hard Zone for ports in multiple zones or share ports that have the Hard Zone option set. This will cause errors that do not log an event or display a message.

The advantages of Hard Zoning include:

- Each Hard Zone contains 126 available AL\_PAs.
- The switch can be configured to contain up to eleven isolated Hard Zones.

The limitations of Hard Zoning include:

- 2 Gb of shared bandwidth over the entire Hard Zone.
- Ports in a Hard Zone cannot use the Stealth Intelligent Change Manager.
- Automatic Trunking and route blocking are not allowed in a Hard Zone.
- Ports in a Hard Zone cannot be set to a string or tree cascade configuration.
- Device AL\_PAs on a port in a Hard Zone cannot be displayed.

The Hard Zone setting is available on the One-Step Zoning page. To view the page, click **Advanced Functions > One-Step Zoning**.

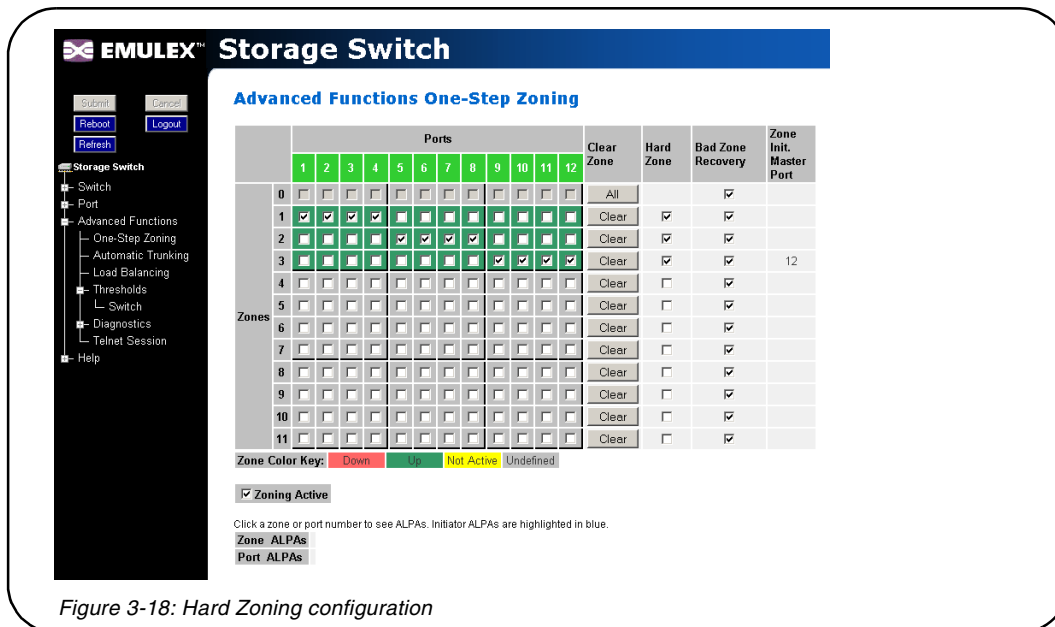

Figure 3-18: Hard Zoning configuration

### To set up Hard Zoning:

1. Determine which ports will reside in each Hard Zone and ensure that the ports are in only one Hard Zone.
2. Under Hard Zone, select the check boxes for the appropriate zones.
3. Click **Submit**.

## AL\_PA Zoning

AL\_PA zoning is a specific zoning configuration that prevents devices from accessing one another. AL\_PA zoning fully ensures that devices will not access each other by blocking a group of devices (using AL\_PAs) from communicating with each other; however, AL\_PA zoning allows the devices to communicate with devices outside of the group.

AL\_PA zoning is only accessible through the Command Line Interface (CLI). Refer to the *Emulex® or InSpeed™ Storage Switch Products' CLI Reference Guide* for additional information.

## Recovering a Bad Zone Automatically

Bad zone recovery policy automatically recovers traffic if a device has brought down the zone. The zone state is monitored continuously. If ports are inserted into a zone, but the zone state never transitions to the Zone Up or Zone Active state after a set period of time (Hold Time), all devices in the pertinent zone are bypassed and then allowed to reinsert. There is a secondary timeout, the Bad Zone Recovery Delay Time, that can also be configured. The Bad Zone Recovery Delay Time causes a delay before ports are allowed to reinsert, which prevents a high "thrashing" level of port insertions and de-insertions and ensures that some devices can reset. The Bad Zone Recovery Hold Time and Delay Time threshold settings are available on the Advanced Functions Switch Thresholds page.

When this policy is enabled with the associated PTBI policy, the device causing a zone to go down is not allowed back into the zone due to the PTBI policy, which allows the system to return to normal operation. The combination of the Bad Zone Recovery and PTBI policies has resulted in significant improvements to SAN availability.

---

**Note:** The Bad Zone Recovery policy is enabled by default. If the Bad Zone Recovery policy is disabled, use the following instructions to enable this policy for the appropriate zones.

---

### To activate bad zone recovery:

1. Click **Advanced Functions > One-Step Zoning**.
2. Under Bad Zone Recovery, select the check boxes for the appropriate zones.
3. Click **Submit**.

## Cascading Switches

When multiple switches are connected, the connecting links between the switches are referred to as "cascades". There are two distinct cascade configurations to consider when configuring networks for optimal performance and connectivity: string cascades and tree cascades.

### String Cascades

A string cascade connects multiple switches (up to three switches maximum) together in a "daisy-chained" configuration. When one device requests access to another device, the request is sent to each switch in the cascade before device access is granted. This arbitration method promotes fairness between the switches. However, when compared to tree cascades, string cascades offer less performance due to the increased latency between the switches.

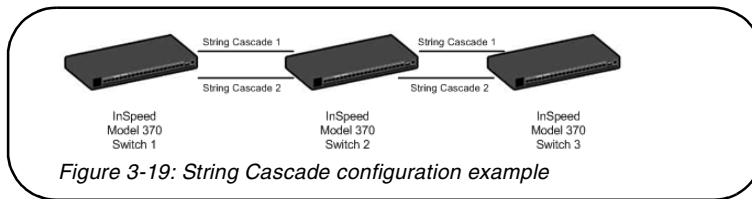

Figure 3-19: String Cascade configuration example

When configuring a switch port for a string cascade, use the String Cascade Smart Setting. To enable the string cascade, go to the Automatic Trunking page. From the Automatic Trunking page, select the Single Cascade option, or place the string cascade into a trunk group. See [“Automatic Trunking” on page 45](#) for additional information.

To reduce contention and improve performance between initiator traffic and target traffic when using a string cascade configuration, connect the ports of each switch together using the same String Cascade Smart Settings. For example, in [Figure 3-19](#) the three switches are connected through two string cascades using the String Cascade - Trunk 1 and String Cascade - Trunk 2 Smart Settings. This creates two dedicated paths through which initiators and targets can communicate.

### Tree Cascades

Tree cascades provide the best performance (lowest latency) configuration. A tree cascade consists of a root switch connected to additional switches (up to 8 switches maximum). When a device on a switch requests access to another device, the request is sent the particular switch for that device. The limitation to the tree cascade configuration is the random nature of devices gaining access to one another, as fairness is not used for tree cascades.

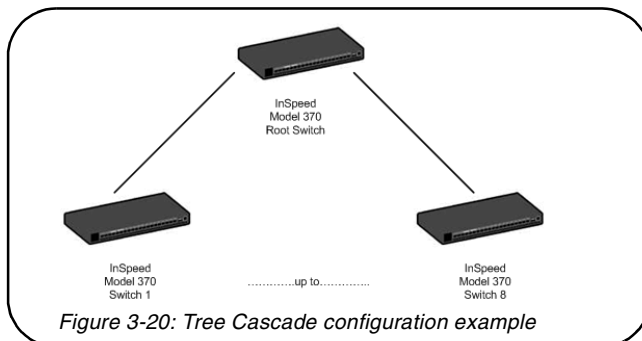

Figure 3-20: Tree Cascade configuration example

When configuring a port for a tree cascade, use the Tree Cascade Smart Setting. To enable the tree cascade, go to the Automatic Trunking page. From the Automatic Trunking page, select the Single Cascade option, or place the tree cascade into a trunk group. See [“Automatic Trunking” on page 45](#) for additional information.

## Automatic Trunking

Multiple links between switches are called “trunks”. Trunks provide higher bandwidth across cascaded switches for systems incorporating multiple initiators. Each trunk can improve system throughput and provide “failover” capability. A maximum of 4 trunks between each switch is supported. Trunking is performed automatically when ports are configured properly. [Figure 3-21](#) is an example of Automatic Trunking.

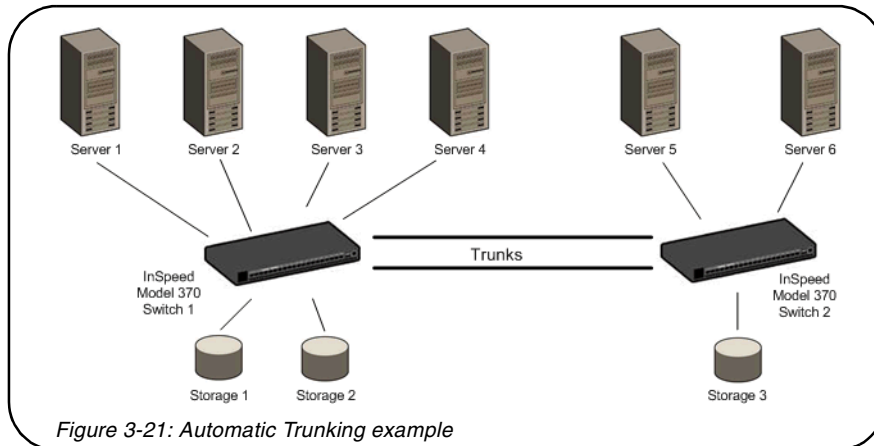

Figure 3-21: Automatic Trunking example

Each trunk is part of a trunk group. A trunk group consists of two or more cascades between two switches, and these cascades must be the lowest numbered ports on both switches. There can only be one trunk group between two switches. Each trunk group contains a primary trunk. All traffic flows through the primary trunk on a switch unless specified otherwise using the Load Balancing feature. The primary trunk is always the lowest numbered port of any trunk group.

If the primary trunk fails, the secondary trunk automatically becomes the primary trunk unless otherwise configured. Multiple cascades also enable switch configuration for better performance through load balancing (see “[Load Balancing](#)” on page 46).

The Automatic Trunking page enables users to configure trunking by defining trunk groups and assigning ports to those groups. The Automatic Trunking feature is available when one or more ports are assigned a String or Tree Cascade Smart Setting.

Only one of the three following options may be selected for each port.

- Device or Initiator – Select this option to designate a specific port as an initiator or device. The specified port is not assigned to a trunk group. The Device or Initiator option is the default setting.
- Single Cascade – Select this option when connecting two switches with a single cascade. The selected port is not part of a trunk group.
- Trunk Group – Select this option when multiple cascades are connected between two switches. The selected port must be assigned to an available trunk group. Multiple trunk groups appear when two or more ports are assigned to the same string cascade Port Smart Setting (for example, String Cascade - Trunk 1).

**Note:** Before changing the Port Smart Setting for a particular port assigned to a trunk group, you must remove that port from the trunk group by selecting the Device or Initiator setting. Remember to click **Submit** to update the port's setting.



**To assign ports to trunk groups:**

1. Click **Advanced Functions > Automatic Trunking**.

The Automatic Trunking page appears.

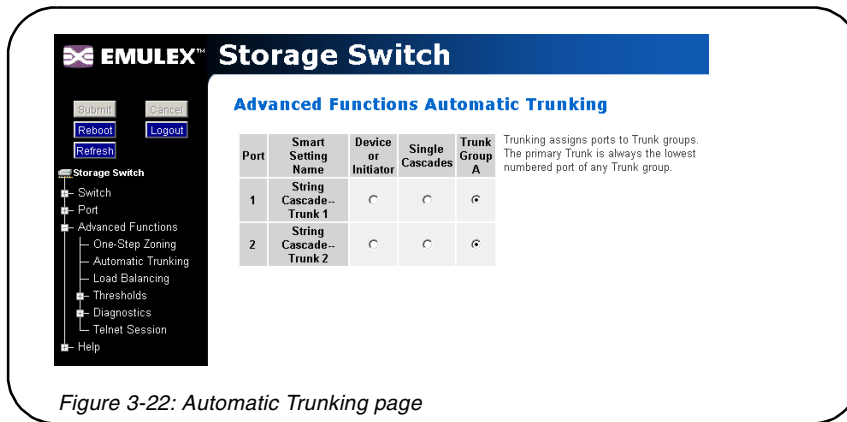

Figure 3-22: Automatic Trunking page

2. Select a trunk group for each port by clicking the appropriate Trunk Group option.
3. When finished making changes, click **Submit**.

## Load Balancing

Load balancing builds on the Automatic Trunking functionality by specifying the path that the data uses to flow between multiple switches. Manage the switch's aggregate bandwidth by manually distributing traffic across multiple cascade ports as shown below. A cascade port is a port that is attached to another switch of the same type and configured as a String or Tree Cascade Smart Setting on the Port Smart Settings page. All data flows through the primary cascade, unless the switch is configured differently.

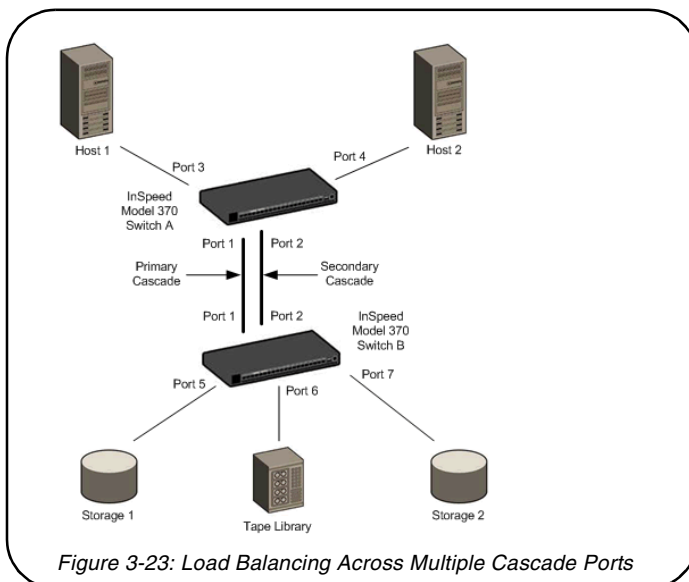

Figure 3-23: Load Balancing Across Multiple Cascade Ports

**Note:** Cascade ports must be properly configured before load balancing will work.

In [Figure 3-23](#), host 1 uses cascade port 1, while host 2 uses cascade port 2. All traffic will use the lowest numbered (primary) cascade port by default but ports may be configured to use other cascades.

**Note:** When tape drives or tape libraries are included in multiple switch configurations incorporating multiple trunks, place the tape drive or tape library and any devices that access those devices on the secondary (duplicate) trunk, not the primary trunk.

Load balancing configuration settings are available on the Web Manager's Load Balancing page. Before implementing load balancing on the switch, the automatic trunking settings must be configured. See ["Automatic Trunking" on page 45](#) for additional information.

**To view the Load Balancing page:**

Click **Advanced Functions > Load Balancing**.

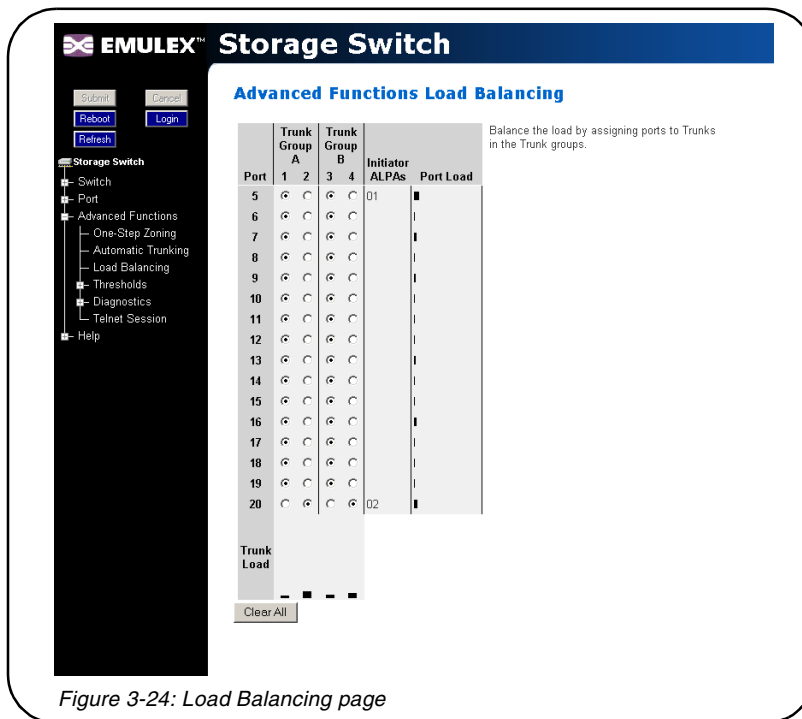

Figure 3-24: Load Balancing page

The page is arranged as a grid of check boxes for assigning ports to cascades ("Trunk Groups").

## Load Indicators

The Load Balancing page incorporates two sets of visual indicators for measuring traffic:

- Port Load Indicators—the horizontal bars on the right side of the page that display the current load for each port.
- Trunk Load Indicators—the vertical bars at the bottom of the page that display the current load for each trunk group.

These bars indicate the amount of traffic across a trunk or port. The size of the bars increase in correlation to the amount of traffic and, as a bar's size increases, can identify a specific trunk or port that is overloaded. If overloading occurs, move one or more ports to a different trunk in the group.

**To change the load balancing settings:**

1. Click a Trunk Group option to place a port into a specific trunk group.
2. Continue to assign ports to trunk groups as necessary.
3. When finished, click **Submit**.

## Fairness and Prioritization

The concept of “fairness” is based on the principle of ensuring fair device access and communication across all devices in a storage system. The switch incorporates fairness and prioritization through InSpeed technology and Automatic Trunking and Load Balancing functionality. In cooperation with each other, these features ensure even and equal access through multiple links fairly—effectively multiplying bandwidth.

Device prioritization can be achieved using Load Balancing and assigning only a specific device port to a particular cascade. This ensures that a specific device will always have a dedicated trunk.

## MONITORING THE SWITCH

The InSpeed Model 370 Embedded Storage Switch provides several options for monitoring the switch status and port information. This section describes how to view switch status, the event log, port information and utilization, and port diagnostics.

### Viewing Switch Status

The Web Manager’s home page is the Switch Information page. This page is displayed first when the Web Manager is opened and shows general switch information, including switch status, fan and power supply operational indicators, and port health and utilization.

This page continually refreshes to guarantee that the most current switch status is displayed. To return to this page at any time, click the **Storage Switch** menu item.

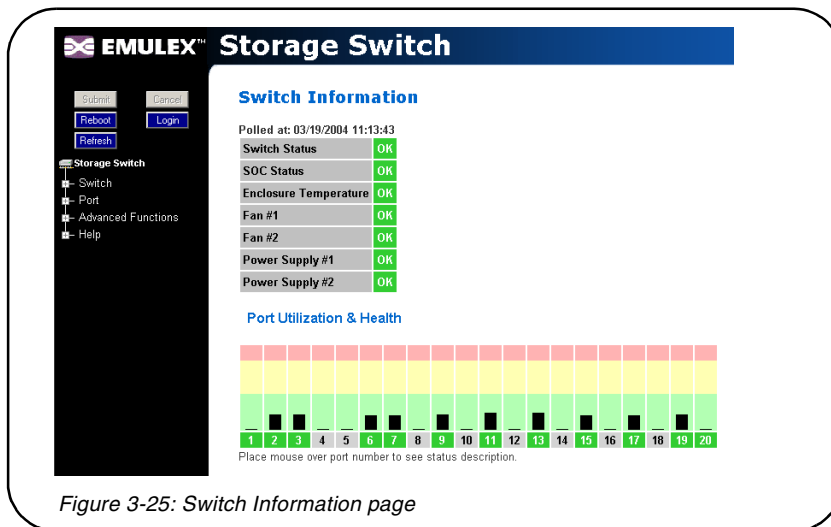

## Switch Information

Current status is provided for the following items.

Item	Status Indicators
<b>Switch Status</b>	<ul style="list-style-type: none"> <li>• OK (green)—the switch unit is operating normally.</li> <li>• Fault (red)—one or more of the ports has failed, the internal temperature has exceeded acceptable levels, or another error has occurred. Errors appear in the event log. The switch will continue to operate; however, functionality may be impaired depending on the event that triggered the error. Regardless of the cause, the switch requires immediate attention.</li> </ul>
<b>SOC Status</b>	<ul style="list-style-type: none"> <li>• OK (green)—the switch chipset is operating normally.</li> <li>• Fault (red)—the switch chipset's selftest has failed.</li> </ul>
<b>Enclosure Temperature</b>	<ul style="list-style-type: none"> <li>• OK (green)—the switch temperature is within the normal operating range.</li> <li>• OverTemp (red)—the enclosure temperature has exceeded the recommended operating range.</li> </ul>
<b>Fan #1</b>	<ul style="list-style-type: none"> <li>• OK (green)—the fan unit is working properly.</li> <li>• Not Present (yellow)—the power supply/fan module has been removed.</li> <li>• Fault (red)—the fan unit has stopped operating. Verify that the power supply/fan module is properly seated in the switch.</li> </ul>
<b>Fan #2</b>	<ul style="list-style-type: none"> <li>• OK (green)—the fan unit is working properly.</li> <li>• Not Present (yellow)—the power supply/fan module has been removed.</li> <li>• Fault (red)—the fan unit has stopped operating. Verify that the power supply/fan module is properly seated in the switch.</li> </ul>
<b>Power Supply #1</b>	<ul style="list-style-type: none"> <li>• OK (green)—the power supply unit is working properly.</li> <li>• Not Present (yellow)—the power supply/fan module has been removed.</li> <li>• Fault (red)—the power supply unit has stopped operating. Verify that the power supply/fan module is properly seated in the switch.</li> </ul>
<b>Power Supply #2</b>	<ul style="list-style-type: none"> <li>• OK (green)—the power supply unit is working properly.</li> <li>• Not Present (yellow)—the power supply/fan module has been removed.</li> <li>• Fault (red)—the power supply unit has stopped operating. Verify that the power supply/fan module is properly seated in the switch.</li> </ul>

## Port Utilization and Health

Port utilization measures the amount of traffic passing into a port over a period of time. For example, if an initiator is transmitting data to a target, the initiator port displays a port utilization value (%) while the target port does not. If the same initiator is receiving data from the target, the target port displays a port utilization value (%) while the initiator port displays does not.

This part of the Web page displays each port number, the port's current health status, and a vertical bar indicating the port utilization.

---

**Tip:** Rolling the mouse cursor over the port number displays the current port state.

---

A port number is displayed in one of three colors depending on the port's current health:

Port Color	Indication
<b>Green</b>	An SFP is inserted into the port and a device is connected to the SFP.
<b>Yellow</b>	<ul style="list-style-type: none"> <li>• Bypassed – The port is bypassed. An SFP may be inserted in the port but there may not be a device connected to the SFP.</li> <li>• Loopback – There is no device connected to the port. The transmit and receiver are connected together on the SFP transceiver.</li> <li>• LIPF8Present – If the switch is receiving an F8 Failure notification, the port is bypassed to allow remaining devices to proceed with initialization.</li> <li>• Redundant – The port is a failover link in a cascade and is not currently active.</li> </ul>
<b>Red</b>	<ul style="list-style-type: none"> <li>• TxFault – Detects an SFP transmitter fault.</li> <li>• DiagTx – Detects Ordered Sets being transmitted, so traffic cannot be passed through the port.</li> <li>• DataTimeout – Detects a data timeout fault.</li> <li>• RxLoss – Detects a loss of received signal amplitude from the device.</li> <li>• SyncLoss – Detects a loss of word synchronization for a specified time, which may be caused by poor signal strength, intermittent line conditions, and so on.</li> </ul>
<b>Gray</b>	<ul style="list-style-type: none"> <li>• Unknown – The port status cannot be determined.</li> <li>• NoSFP – There is no SFP connector inserted in the port.</li> </ul>

Port utilization is measured by a vertical bar that moves upwards as utilization increases. The vertical bar has the three distinct levels of utilization:

Bar Color	Indication
<b>Green</b>	The port is operating at optimal utilization.
<b>Yellow</b>	The port is experiencing periods of heavy traffic.
<b>Red</b>	The port has too much traffic on it and is not operating at desired levels. Some devices should be transferred to other ports to improve port utilization.

## Viewing the Event Log

The Event Log contains a list of up to 3000 event log messages generated by the switch. The Switch Event Log page displays the event log messages with each message containing the following information:

- Event Number – the number assigned to that specific event in the log.
- Event Date and Time – the date and time when the event was recorded in the log.
- Event Severity – the severity level for that event.
- Event Type – the identifier assigned to that event.
- Event Description – a brief description of the event.

For a complete list of event messages and severity levels, see [Appendix C: Event Messages on page 67](#).

### To view the event log:

Click **Switch > Event Log**.

The Event Log Messages page appears.

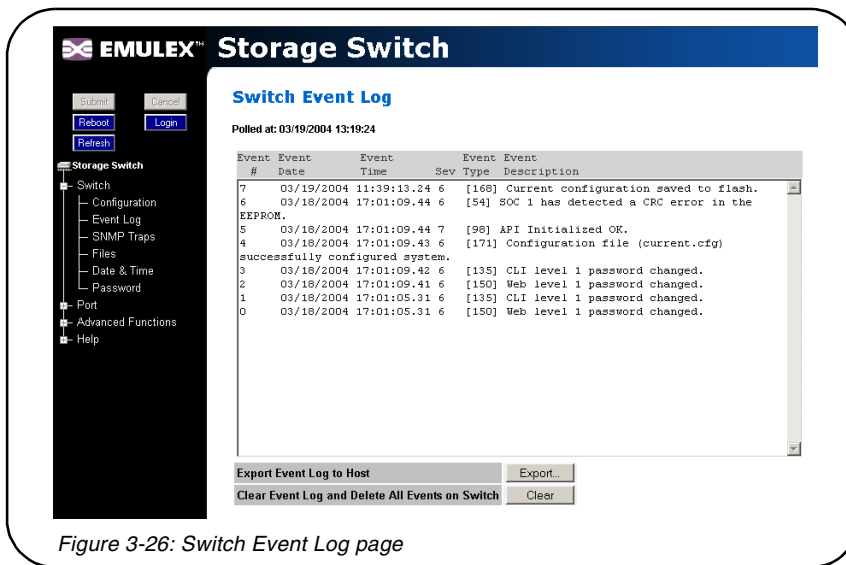

Figure 3-26: Switch Event Log page

The last time the event log was polled appears at the top of the page.

### To export the event log:

1. Click **Export**.

If the File Download dialog box appears, select **Save this file to disk**, and click **OK** to save the file on the host system. The Save As dialog box appears. Select the appropriate directory, change the file name if necessary, and click **Save**.

The event log appears in the host system's default text editor.

2. Select the appropriate directory to save the event log messages, change the name of the file (if desired), and save the event log.

### To delete the current list of event log messages on the switch:

1. Click **Clear**.

A message box appears confirming the request.

2. Click **OK** to delete the event log.

The event log is cleared out and a new event message is displayed reporting that the event log has been cleared.

## Viewing Port Information

The Port Information page displays the Smart Settings, Serial ID (SID), and AL\_PAs currently assigned to each port. Initiator AL\_PAs are highlighted in blue to differentiate them from target AL\_PAs.

**Note:** The Initiator AL\_PA information can be used to easily identify attached devices when configuring load balancing.

To view port information:

Click **Port > Information**.

The Port Information page appears.

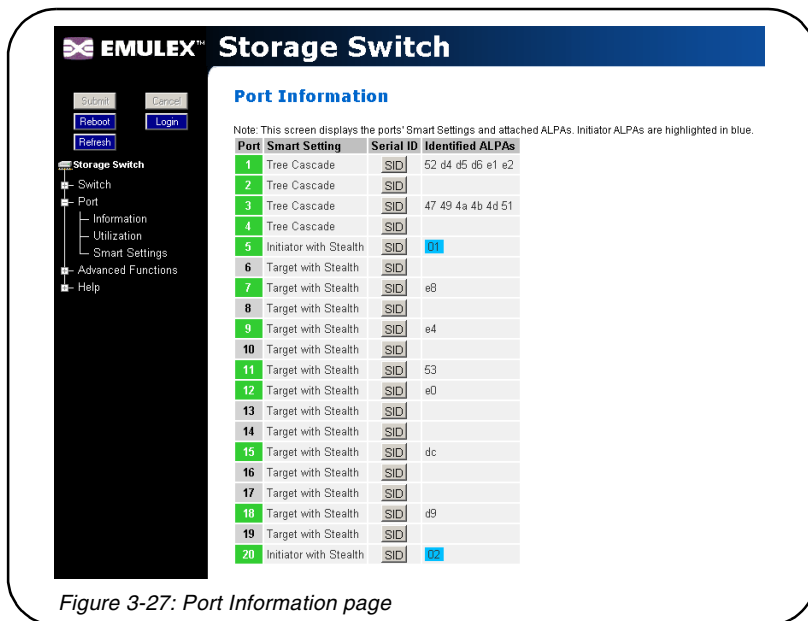

Figure 3-27: Port Information page

Field	Description
<b>Port</b>	Displays the current health of the port. See <a href="#">“Port Utilization and Health” on page 50</a> for additional information on port health.
<b>Smart Setting</b>	Displays the specific Smart Setting assigned to a particular port. See <a href="#">“Configuring the Port Smart Settings” on page 28</a> for more information on the Smart Settings.
<b>Serial ID (SID)</b>	When clicked, provides additional information about the SFP inserted in the port, if an SFP is inserted in that particular port.
<b>Identified ALPAs</b>	Displays all the AL_PAs attached to the port. Initiator AL_PAs appear highlighted in blue.

## Viewing Port Utilization

Port utilization measures the amount of traffic passing into a port over a period of time. For example, if an initiator is transmitting data to a target, the initiator port displays a port utilization value (%) while the target port does not. If the same initiator is receiving data from the target, the target port displays a port utilization value (%) while the initiator port displays does not.

The Port Utilization page displays each port's utilization percentage based on high, average, and low utilization.

Value	Description
<b>High</b>	The highest percentage of data communication through a port over a period of time (measured in seconds).
<b>Average</b>	The average percentage of data communication through a port over a period of time (measured in seconds).
<b>Low</b>	The lowest percentage of data communication through a port over a period of time (measured in seconds).

### To change the port utilization interval:

Click **Advanced Functions > Thresholds > Switch**. See [“Adjusting the Switch Thresholds” on page 27](#) for additional information.

### To view port utilization:

Click **Port > Utilization**.

The Port Utilization page appears.

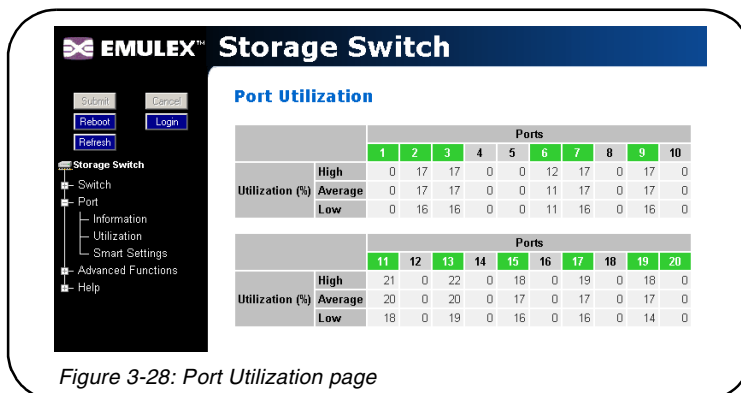

Figure 3-28: Port Utilization page



## Viewing Port Diagnostics

This page displays diagnostic information pertaining to each port in the switch. Use the information provided on this page to diagnose abnormally high error counts on a particular port.

### To view the current diagnostic settings:

Click **Advanced Functions > Diagnostics > Port**.

The Port Diagnostics page appears.

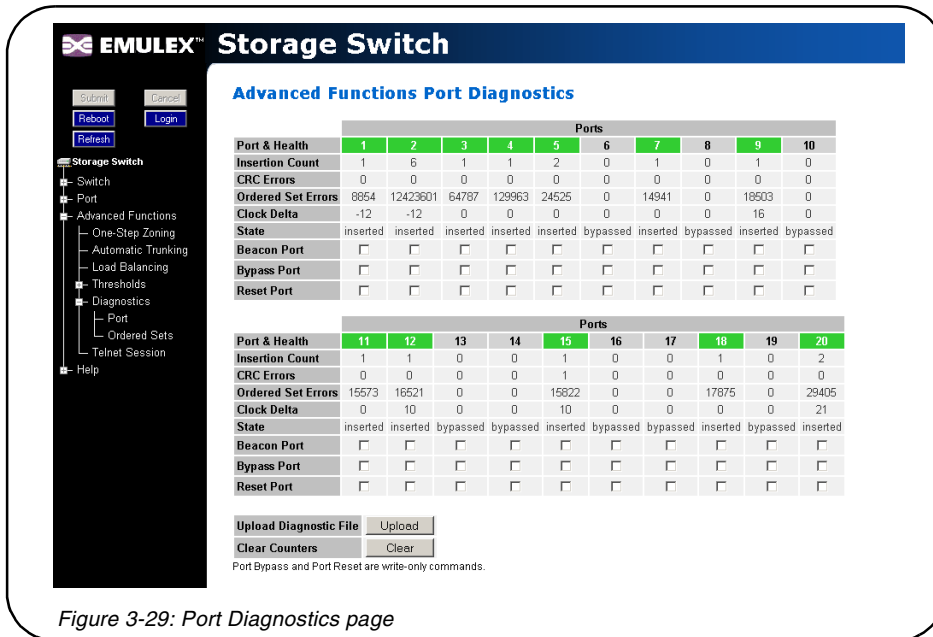

Figure 3-29: Port Diagnostics page

Statistic	Description
<b>Port &amp; Health</b>	Color Indicators <ul style="list-style-type: none"> <li>• Green</li> <li>• Yellow</li> <li>• Red</li> </ul> See “Port Utilization and Health” on page 50 for descriptions of the health indicators.
<b>Insertion Count</b>	Number of times this port has been inserted into the network since the switch was reset or the counters were cleared.
<b>CRC Errors</b>	Number of CRC errors that are detected in frames passing through this port since the switch was reset or the counters were cleared.
<b>Ordered Set Errors</b>	Number of Ordered Sets that are received on this port with an encoding error since the switch was reset or the counters were cleared.
<b>Clock Delta</b>	Difference (in parts per million) between the internal switch clock and the received clock signal on the port.
<b>State</b>	Current state of this port – either inserted or bypassed
<b>Beacon Port</b>	Forces both port LEDs to flash on and off continuously. Use this to locate and take action on a specific port. The flashing overrides normal port indication until beaconing is turned off; however, port operation continues to operate normally.

Statistic	Description
<b>Bypass Port</b>	A single instance operation that forces a port into bypass mode. This feature may be used to diagnose device problems when a device is locked up or experiencing a high number of failures on a port.
<b>Reset Port</b>	A single instance operation that places a port in bypass mode and then immediately sets the port to auto-detect to re-insert the port. This feature may be used to diagnose device problems when a device is locked up or experiencing a high number of failures on a port.

**To save diagnostic information:**

1. Click **Upload** to save the current diagnostics to the host system.
2. Click **OK** on the File Download dialog box.
3. Enter the directory path and file name.
4. Click **Save**.

**To clear the counters:**

Click **Clear**.

**Manual Port Operation**

If necessary, a port can be placed into manual bypass mode or reset. If the port is placed in bypass mode, the port will remain in bypass mode until the switch is reset. If the port is manually reset, the port is temporarily placed in bypassed mode and then reset to re-insert the port. These features may be used to diagnose device problems when a device is locked up or experiencing a high number of failures on a port.

**To place a port into bypassed mode:**

1. Click **Advanced Functions > Diagnostics > Port**.
2. Select the Bypass Port option for the appropriate port.
3. Click **Submit**.

**To reset a port:**

1. Click **Advanced Functions > Diagnostics > Port**.
2. Select the Reset Port option for the appropriate port.
3. Click **Submit**.

## Viewing Ordered Sets

This page displays the Ordered Sets that are being transmitted on the switch for each port since the last time the page was displayed. Ordered Sets are used when communicating data across networks to indicate actions, events, or status regarding the data. A list of detected Ordered Sets and their indications is provided below.

### To view ordered sets:

1. Click **Advanced Functions > Diagnostics > Ordered Sets**.

The Ordered Sets page appears.

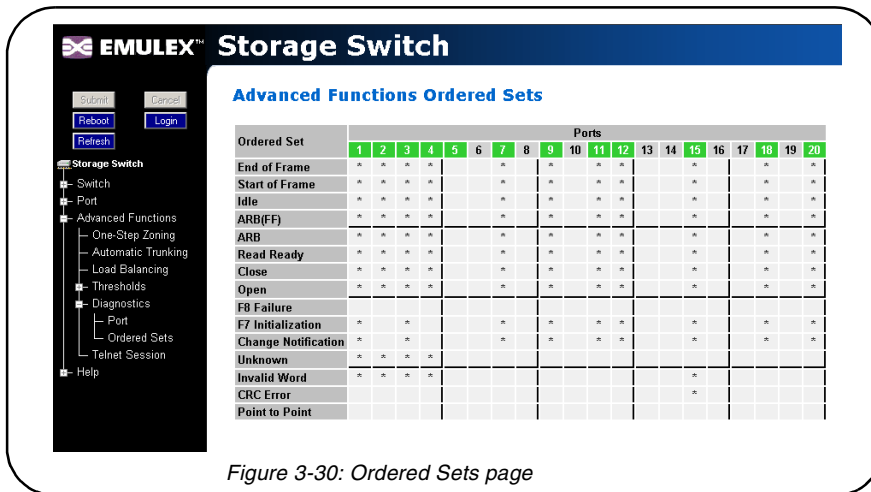

Figure 3-30: Ordered Sets page

Detection	Indication
<b>End of Frame (EOF)</b>	An End-of-Frame (EOF) delimiter has been detected; frames are present. (An EOF immediately follows the CRC of a frame and signals the frame's end.)
<b>Start of Frame (SOF)</b>	A Start-of-Frame (SOF) delimiter has been detected; frames are present.
<b>Idle</b>	Sequences of IDLEs are being transmitted to maintain link activity; no other data is being transmitted.
<b>ARB(FF)</b>	ARB(FF)s are being transmitted to maintain link activity; no other data is being transmitted.
<b>ARB</b>	A port is arbitrating for network access to perform a task.
<b>Read Ready (RRDY)</b>	The receiving node on this port has sent an R_RDY signal, indicating that it is ready for a frame to be transmitted over the link.
<b>Close (CLS)</b>	The port is attempting to begin the process of closing the current FC-AL circuit.
<b>Open (OPN)</b>	The port is attempting to open communications with another port. <b>Note:</b> As is the case with some ordered sets, an OPN may not go all the way around the FC-AL, instead stopping at its destination.
<b>F8 Failure</b>	A non-switching port has detected a failure on its receive input, is notifying other ports, and is determining whether the network is still operational. Some events that could cause the port to detect network failure follow: <ul style="list-style-type: none"> <li>• A device has failed or has been powered off.</li> <li>• The physical connection between the transmitter and receiver is broken.</li> <li>• Activating the port bypass circuit does not typically result in a network failure.</li> </ul>

Detection	Indication
<b>F7 Initialization</b>	A port is in the non-participating mode and is attempting to win arbitration and begin initialization, possibly because the port was reset or is powering up. Sometimes the port is sending this sequence to another hot-cascaded switch, like a new initiator being inserted in the network.
<b>Change Notification</b>	A change notification has been detected and action has been taken.
<b>Unknown</b>	The switch cannot determine what is being transmitted.
<b>Invalid</b>	An invalid transmit word has been detected.
<b>CRC Error</b>	A Frame CRC error has been detected.
<b>Point-to-Point</b>	A point-to-point connection has been detected.

# CHAPTER 4 TECHNICAL REFERENCE

---

Troubleshooting Device Connections..... 58

Troubleshooting Management Connections ..... 59

Port Bypass Conditions and Recovery ..... 59

Default Smart Setting Attributes..... 60

Fibre Channel References ..... 61

---

## TROUBLESHOOTING DEVICE CONNECTIONS

Problem	Recommended Action
<b>SFP installed in one or more ports but no LEDs lit</b>	<ol style="list-style-type: none"> <li>1. Verify that the power cord is firmly seated into switch and is connected to a properly earthed receptacle (outlet).</li> <li>2. Check the Power LED to ensure that the switch is turned on.</li> <li>3. Verify that the SFP is firmly seated.</li> </ol>
<b>SFP installed but only yellow LED is lit</b>	<p>Reseat the SFP. If the same condition occurs, the SFP is probably faulty and should be replaced.</p>
<b>SFP installed with both green and yellow LEDs lit</b>	<ol style="list-style-type: none"> <li>1. Make sure that the device is powered on and operating properly.</li> <li>2. Unplug the fiber cable from the node and verify that an optical signal is present on the cable receiver lead.</li> <li>3. Verify that the fiber cable is fully seated at either end.            If optical power meter is available, verify the device is transmitting a signal.            If there is no signal present, the device may require rebooting, device drivers may need to be reinstalled, or the HBA or disk controller hardware may require servicing.            If a signal is present on both the cable lead and the end node, the HBA or disk controller may require service.</li> <li>4. Ensure that the device and switch are operational and set to the same speed.</li> </ol>
<b>SFP installed with only green LED lit, but devices are not communicating</b>	<p>The switch is receiving a valid signal from the device, but no upper level protocols are active.</p> <ol style="list-style-type: none"> <li>1. Verify that the proper HBA device drivers are loaded for the appropriate operating system and that the host has been configured to recognize attached disk devices.</li> <li>2. Improper FC-AL initialization could result from a defective or inoperative adapter card or device. Run adapter diagnostics with a loopback connector to see if the adapter is working properly.</li> <li>3. Unplug the fiber cable from the end node and verify that an optical signal is present on the cable receiver lead. If no signal is present, the cable's receiver lead may be bad and the device may be streaming F8 Failure notifications.</li> </ol>

## TROUBLESHOOTING MANAGEMENT CONNECTIONS

Problem	Recommended Action
<b>Serial cable installed but connection does not appear on terminal</b>	<ol style="list-style-type: none"> <li>1. Cycle power by reinstalling the power cord.</li> <li>2. Check the terminal emulation program's serial port parameters.</li> <li>3. Replace the serial cable. (Make sure it is a null modem cable.)</li> </ol>
<b>Ethernet cable installed but Web Manager does not appear</b>	<ol style="list-style-type: none"> <li>1. Ensure that a crossover ethernet cable is used (unless using an ethernet hub).</li> <li>2. Check the IP addresses on the switch and workstation as follows: At a command line prompt, type <b>ping DNSorIP</b> (where DNSorIP is the switch's DNS name or IP address) and press ENTER. If a "Reply from..." or "...is alive..." message appears, the devices can communicate. If a "Request timed out" message appears (or the command times out), the devices cannot communicate. Trace the cabling. If needed, reconnect the devices.</li> </ol>

## PORT BYPASS CONDITIONS AND RECOVERY

Operational Condition	Recovery
<b>Rx_los is asserted by an SFP/GBIC</b>	The port stays bypassed until rx_los is de-asserted. At that time, the port insertion will be automatically retried. The port continues to stay bypassed until the port can pass the port insertion criteria.
<b>Tx_fault is asserted by an SFP/GBIC</b>	The port stays bypassed until tx_fault is de-asserted. At that time, the port insertion will be automatically retried. The port continues to stay bypassed until the port can pass the port insertion criteria.
<b>F8 Failure notification is received by the port (when the LIP F8 Recover policy is enabled)</b>	The switch automatically tries to re-insert the device, by sending F7 Initialization notifications to the device connected to the bypassed port. The port continues to stay bypassed until the device returns F7 Initialization notifications to the port and passes the port insertion criteria.
<b>Loss of Sync (&gt;100ms)</b>	The port stays bypassed until a signal is re-established. At that time, the port insertion will be automatically retried. The port continues to stay bypassed until the port can pass the port insertion criteria.
<b>Firmware Initiated</b>	The port stays bypassed until the firmware sets the port control back to automatic. At that time, the port insertion will be automatically retried. The port continues to stay bypassed until the port can pass the port insertion criteria.

## DEFAULT SMART SETTING ATTRIBUTES

	Initiator or Target	Initiator with Stealth	Target with Stealth	Fabric Connection	Tree Cascade	String Cascade --Trunk 1	String Cascade --Trunk 2	String Cascade --Trunk 3	String Cascade --Trunk 4
<b>Smart Setting Name</b>	Initiator or Target	Initiator with Stealth	Target with Stealth	Fabric Connection	Tree Cascade	String Cascade --Trunk 1	String Cascade --Trunk 2	String Cascade --Trunk 3	String Cascade --Trunk 4
<b>Smart Setting Type</b>	Initiator or Target Port	Initiator or Target Port	Initiator or Target Port	Tree Cascade	Tree Cascade	String Cascade 1	String Cascade 2	String Cascade 3	String Cascade 4
<b>Smart Insertion Policy</b>	Enabled	Enabled	Enabled	Enabled	Enabled	Enabled	Enabled	Enabled	Enabled
<b>Port Test Before Insert Policy</b>	Enabled	Enabled	Enabled	Disabled	Disabled	Disabled	Disabled	Disabled	Disabled
<b>Stealth Intelligent Change Manager</b>	Off: No Change Protection	Initiator: Only Receive Changes	Target: Only Send Changes	Off: No Change Protection	Switch-Switch: Send and Receive Changes	Switch-Switch: Send and Receive Changes	Switch-Switch: Send and Receive Changes	Switch-Switch: Send and Receive Changes	Switch-Switch: Send and Receive Changes
<b>Change Notification on Insertion Policy</b>	Enabled	Enabled	Enabled	Enabled	Enabled	Enabled	Enabled	Enabled	Enabled
<b>Change Notification on Removal Policy</b>	Enabled	Enabled	Enabled	Enabled	Enabled	Enabled	Enabled	Enabled	Enabled
<b>Bad Device Recovery Policy</b>	Disabled	Enabled	Disabled	Disabled	Disabled	Disabled	Disabled	Disabled	Disabled
<b>Clear on Stall Policy</b>	Enabled	Enabled	Enabled	Enabled	Enabled	Enabled	Enabled	Enabled	Enabled
<b>Bypass on No Activity Policy</b>	Enabled	Enabled	Enabled	Enabled	Enabled	Enabled	Enabled	Enabled	Enabled
<b>Bypass on OS Error Policy</b>	Disabled	Disabled	Disabled	Disabled	Disabled	Disabled	Disabled	Disabled	Disabled
<b>Bypass on CRC Error Policy</b>	Disabled	Disabled	Disabled	Disabled	Disabled	Disabled	Disabled	Disabled	Disabled
<b>Port Control</b>	Auto	Auto	Auto	Auto	Auto	Auto	Auto	Auto	Auto
<b>Bypass on Clock Delta Policy</b>	Disabled	Disabled	Disabled	Disabled	Disabled	Disabled	Disabled	Disabled	Disabled

## FIBRE CHANNEL REFERENCES

The following books give useful information about Fibre Channel.

- Alan F. Benner, *Fibre Channel*. McGraw-Hill, 1996. ISBN 0-07-005669-2.
- Tom Clark, *Designing Storage Area Networks*. Addison Wesley Longman, 1999, ISBN 0-201-61584-3.
- Jan Dedek, *Fibre Channel - The Basics*. ANCOT Corporation, 1997. ISBN 0-9637439-3-7.
- Robert Kembel, *Arbitrated Loop*. Connectivity Solutions, 1996. ISBN 0-931836-82-4.
- Robert Kembel, *A Comprehensive Introduction*. Connectivity Solutions, 1998. ISBN 0-931836-84-0.



# Appendices

# APPENDIX A Specifications

## SWITCH SPECIFICATIONS

Specification	Value
Number of Ports	20
Operating Rate	All ports operate at 1.0625 or 2.125 Gbps (selectable)
Port Media Type	SFP
Enclosure	1U full-rack form-factor
Management Interface	RS-232 or 10/100 Ethernet
Operating Mode	Switching or Non-switching modes
Configurability	Management interface configurable
Power On Selftest (POST)	Yes
Dimensions	17.20" x 1.57" x 17.50" (W x H x D)
AC Power Input	50 or 60 Hz / 100 – 250 VAC / 1.0 – 0.5 A
AC Power Connector	IEC connector
Weight	Approximately 18 lbs.

## OPERATING CONDITIONS

The switch must be operated in a clean, dry environment with unrestricted airflow. Air flows in through the cosmetic end and out through the business end (sometimes called the transceiver end or “back-of-box”).

To avoid overheating, maintain a minimum clearance of two inches (50.8 millimeters) on each end of the switch (the cosmetic end and the business end). Allow an adequate amount of space on the top and sides of the switch for proper air ventilation. Do not place the switch on heat-generating surfaces. Operating conditions are listed below.

Requirement	Value
Operating Temperature	0°C to 40°C normal operation (ambient air temperature)
Storage	-40°C to 80°C non-condensing
Power	50 or 60 Hz / 100 – 250 VAC / 1.0 – 0.5 A

# APPENDIX B CLI Quick Reference

---

Connecting to the CLI .....	64
Logging In and Out .....	64
Using the CLI .....	65
Frequent Switch Configuration Tasks .....	65
CLI Commands .....	66

---

## CONNECTING TO THE CLI

The Command Line Interface (CLI) can be accessed through a network interface using a terminal emulation program, such as HyperTerminal, or through the serial interface from a local computer. Refer to the *Emulex® or InSpeed™ Storage Switch Products' CLI Reference Guide* for detailed descriptions of CLI commands and usage.

### To connect through a network interface:

Use a network terminal emulation program. For example, if using the telnet command on a Windows workstation, type **telnet** *IPaddress* at a command prompt.

### To connect through a serial interface:

1. Attach one end of the included RS-232 null modem cable to the computer's DB-9 serial port, and attach the other end to the switch's DB-9 serial port.
2. Open a terminal session through a serial terminal emulation program (such as HyperTerminal®) with the appropriate serial port (for example, COM1) and the following serial port parameters:
  - Bits per second: 19200
  - Data bits: 8
  - Parity: None
  - Stop bits: 1
  - Flow control: None
3. If using HyperTerminal, press ENTER to receive a prompt.
4. If using the **tip** command on a UNIX workstation, do the following:
  - a. View the `/etc/remote` file and create an alias similar to `Hardware` but with the serial port parameters above. (Suggested name: `Switch`)
  - b. Use the **tip** command to establish a connection through the created alias, for example **tip switch**. (For more information, see the **tip** command Manual page.)

## LOGGING IN AND OUT

The CLI does not require login if only viewing basic system information. However, for viewing detailed system information or configuring any switch settings, users must log in to the switch.

### To log in to the CLI:

Type the password at the prompt and press ENTER. (The default password is **password**.)

### To log out of the CLI:

Type **lo** and press ENTER, or exit the terminal session.

## USING THE CLI

The CLI enables users to monitor and change system and port configurations, configure One-Step Zoning, Automatic Trunking, Load Balancing, and event reporting parameters, and download and install firmware.

For additional information on the CLI, see the *Emulex® or InSpeed™ Storage Switch Products' CLI Reference Guide*.

### To enter a command:

Type the command text or the number of the command.

### To return to the previous menu:

Type `..` and press ENTER.

### To return directly to the Root menu:

Type `root` and press ENTER.

### To cancel a prompt or input request:

Press ENTER.

### To display help for specific command:

Type `? <command>` and press ENTER.

### To save changes to the switch configuration at any time:

1. Type `save` at any command prompt and press ENTER.  
A message appears confirming the request.
2. Type `y` and press ENTER.

## FREQUENT SWITCH CONFIGURATION TASKS

A list of frequent switch configuration-related tasks is provided below. The list displays the task and the corresponding CLI command.

To...	Type...
View switch status	<code>show sysinfo</code>
Change general switch configuration	<code>config sys</code>
Change the IP Address	<code>config network ip</code>
Change the switch speed	<code>config sys speed</code>
View the event log	<code>show events</code>
Upgrade the firmware	<code>fw</code>
Change the port settings	<code>config port</code>
Configure zoning	<code>config zone</code>
Configure trunking	<code>config load</code>
Configure load balancing	<code>config trunk</code>
Reset the switch	<code>reset</code>
Perform diagnostics	<code>diag</code>
Reset the switch to factory default settings	<code>config default</code>
Change the password	<code>config password</code>

## CLI COMMANDS

All of the CLI commands for the InSpeed™ Model 370 Embedded Storage Switch are shown below in a tree diagram. Using the “help” command at the command line may provide additional information.

root -->	1. config -->	1. save			
help		2. sys -->	1. speed	8. lipen	15. fault
li			2. mode	9. name	16. evclr
lo			3. oserr	10. location	17. clrled
save			4. crcerr	11. contact	18. ..
			5. blkarb	12. syslog	19. ?
			6. clkd	13. events	
			7. time	14. sev	
		3. default			
		4. port -->	1. beacon	5. view	9. ..
			2. show	6. edit	10. ?
			3. types	7. del	
			4. add	8. type	
		5. password			
		6. load -->	1. show	5. delalpa	9. pu1
			2. lbclr	6. addalpa	10. pu2
			3. delprt	7. ialpa	11. ..
			4. addprt	8. util	12. ?
		7. trunk -->	1. addprt	3. showmem	5. ..
			2. delprt	4. clr	6. ?
		8. network -->	1. reset	4. mask	7. ?
			2. show	5. gateway	
			3. ip	6. ..	
		9. zone -->	1. bzht	7. deact	13. hz
			2. bzdt	8. zstate	14. bzs
			3. addprt	9. zclr	15. alpas
			4. delprt	10. addblk	16. ..
			5. showmem	11. delblk	17. ?
			6. act	12. showblks	
		10. ..			
		11. ?			
	2. diag -->	1. galpa	5. delta	9. beacon	13. ..
		2. glim	6. showpri	10. con	14. ?
		3. os	7. prtctrs	11. who	
		4. ps	8. clrctr	12. ialpa	
	3. show -->	1. events	6. sysinfo	11. glim	16. sid
		2. ptype	7. zninfo	12. sensors	17. zalpas
		3. portinfo	8. lbinfo	13. getcon	18. ..
		4. prtctrs	9. os	14. sync	19. ?
		5. clrctr	10. galpa	15. dump	
	4. fw -->	1. tftp	3. revert	5. reset	7. ?
		2. xmodem	4. show	6. ..	
	5. reset				
	6. ?				

## APPENDIX C Event Messages

The event messages for the switch are listed below. For explanations, contact a customer service representative. The message's applicable severity level as defined below is also provided.

Severity Level	Severity	Description
1	EMERG	Immediate action required; system failing
2	ALERT	Unrecoverable condition reported; major event in progress
3	CRIT	Event failed with possible loss of integrity
4	ERR	Condition failed; action required
5	WRN	Failed event occurred; no action required
6	NOTIFY	Configuration error or abnormal event occurred; no action required
7	INFO	Event occurred; no action required

These severity levels can be used to designate which events trigger trap messages. Use the Command Line Interface (CLI) to designate the minimum severity level of events to be logged in the Event Log and at which severity level to illuminate the switch's Fault LED.

Event	Event Message	Severity
1	Message log cleared	INFO
5	Power Supply # Failed	ALERT
6	Power Supply # Online	NOTIFY
7	Power Supply # Removed	ALERT
8	Power Supply # Inserted	NOTIFY
9	Fan has stopped	EMERG
10	Fan has returned	ALERT
19	Temperatures over limit	ALERT
20	Temperature OK	INFO
50	SPF Overvoltage	EMERG
54	SOC has detected a CRC error in the EEPROM	NOTIFY
70	Port # bypassed	NOTIFY
71	Port # inserted	NOTIFY
72	Transceiver detected at Port #	NOTIFY
73	Transceiver removed at Port #	NOTIFY
74	SEOC occurred on Port #	NOTIFY
75	Port # exceeded OS threshold	NOTIFY
76	Port # exceeded CRC threshold	NOTIFY
77	Loop UP on Port #	NOTIFY
78	Loop DOWN on Port #	NOTIFY
79	Port # received a LIP(F8)	WRN
80	Port # CRC Error detected in frame	WRN
81	Port # did not receive LIP(F7) within timeout	WRN

Event	Event Message	Severity
83	Segment stall on Port #	NOTIFY
84	Bad Open on Port #	WRN
85	Error during Port Disc.	NOTIFY
86	Port # PTBI failed due to timeout	NOTIFY
87	Port # changed to <state>	NOTIFY
88	Transceiver in Port # has been cycled	NOTIFY
89	Port # has cycled between insert/bypassed (not necessarily in that order)	NOTIFY
90	Loop CYCLED on Port #	NOTIFY
91	Port exceeded Clk Delta threshold	INFO
95	Interframe has been received	INFO
96	Interswitch link added/removed	INFO
97	LIP Cycle Timeout	INFO
98	API Initialized OK	INFO
99	Selftest failure	ERR
100	Received Unknown event	INFO
101	CRC detected on either an ISL LIP or Generic Frame	NOTIFY
107	Trap task failed to update trap destination info.	CRIT
135	CLI level 1 password changed	NOTIFY
136	CLI level password changed to default setting	NOTIFY
150	Web level 1 password changed	NOTIFY
151	Web password level changed to default setting	NOTIFY
165	System config reset to factory default	ERR
166	New Port Config Type added	NOTIFY
167	Port Config Type deleted	NOTIFY
168	Current Config saved to flash	NOTIFY
169	Error in saving config file to flash	ERR
170	Error in retrieving config information	ERR
171	Config File successfully configured system	NOTIFY
172	Error in initializing system with config file	ERR
198	A device tried to access another device that was not in the same zone	NOTIFY
199	Health timer has expired on Zone #	NOTIFY
208	Port # is over threshold	NOTIFY
218	Trunk DOWN on Port #	NOTIFY
219	Trunk UP on Port #	NOTIFY
220	New Primary Trunk	NOTIFY

# APPENDIX D AL\_PA Cross References

Arbitrated Loop Physical Addresses								
AL_PA	AL_PA ID		AL_PA	AL_PA ID		AL_PA	AL_PA ID	
(hex)	(hex)	(decimal)	(hex)	(hex)	(decimal)	(hex)	(hex)	(decimal)
EF	00	0	A3	2B	43	4D	56	86
E8	01	1	9F	2C	44	4C	57	87
E4	02	2	9E	2D	45	4B	58	88
E2	03	3	9D	2E	46	4A	59	89
E1	04	4	9B	2F	47	49	5A	90
E0	05	5	98	30	48	47	5B	91
DC	06	6	97	31	49	46	5C	92
DA	07	7	90	32	50	45	5D	93
D9	08	8	8F	33	51	43	5E	94
D6	09	9	88	34	52	3C	5F	95
D5	0A	10	84	35	53	3A	60	96
D4	0B	11	82	36	54	39	61	97
D3	0C	12	81	37	55	36	62	98
D2	0D	13	80	38	56	35	63	99
D1	0E	14	7C	39	57	34	64	100
CE	0F	15	7A	3A	58	33	65	101
CD	10	16	79	3B	59	32	66	102
CC	11	17	76	3C	60	31	67	103
CB	12	18	75	3D	61	2E	68	104
CA	13	19	74	3E	62	2D	69	105
C9	14	20	73	3F	63	2C	6A	106
C7	15	21	72	40	64	2B	6B	107
C6	16	22	71	41	65	2A	6C	108
C5	17	23	6E	42	66	29	6D	109
C3	18	24	6D	43	67	27	6E	110
BC	19	25	6C	44	68	26	6F	111
BA	1A	26	6B	45	69	25	70	112
B9	1B	27	6A	46	70	23	71	113
B6	1C	28	69	47	71	1F	72	114
B5	1D	29	67	48	72	1E	73	115
B4	1E	30	66	49	73	1D	74	116
B3	1F	31	65	4A	74	1B	75	117
B2	20	32	63	4B	75	18	76	118
B1	21	33	5C	4C	76	17	77	119
AE	22	34	5A	4D	77	10	78	120
AD	23	35	59	4E	78	0F	79	121
AC	24	36	56	4F	79	08	7A	122
AB	25	37	55	50	80	04	7B	123
AA	26	38	54	51	81	02	7C	124
A9	27	39	53	52	82	01	7D	125
A7	28	40	52	53	83	00	7E	126
A6	29	41	51	54	84	---	7F	127
A5	2A	42	4E	55	85	---	---	---



# APPENDIX E Glossary

<b>AL_PA or Arbitrated Loop Physical Address</b>	A one-byte value used to identify a port in an Arbitrated Loop topology. The value of the AL_PA corresponds to bits 7:0 of the 24-bit Native Address Identifier.
<b>Arbitration</b>	The process of selecting one respondent from a group requesting service at the same time.
<b>Close (CLS)</b>	An Arbitrated Loop protocol used to terminate a loop circuit.
<b>Current Fill Word</b>	The fill word that the Loop Port State Machine uses when a fill word is to be transmitted.
<b>Duplex Cable</b>	Two fibers in one cable suitable for duplex transmission.
<b>Fiber Optics</b>	Light transmission through optical fibers for communication or signaling
<b>Fibre Channel</b>	Fibre Channel is a data transfer interface technology that maps several common transport protocols including IP and SCSI, allowing it to merge high-speed I/O and networking functionality in a single connectivity technology. Fibre channel is an open standard as defined by ANSI and OSI standards and operates over copper and fiber optic cabling at distances of up to 10 Kilometers. It is unique in its support of multiple interoperable topologies including point-to-point, arbitrated-loop and switching and it offers several qualities of service for network optimization. With its large packet sizes, Fibre Channel is ideal for storage, video, graphic and mass data transfer applications.
<b>LED</b>	Light-Emitting Diode. A status indicator on a switch.
<b>Gb/s</b>	Gigabits per second.
<b>Node</b>	An entity with one or more N_Ports or NL_Ports.
<b>Open (OPN)</b>	An Arbitrated Loop protocol used to establish a loop circuit.
<b>Protocol</b>	A data transmission convention which may include timing, control, formatting, error detection with correction and data representation.
<b>SCSI</b>	Small Computer System Interface. Standard interface for storage modules.
<b>SFP</b>	Small Form-Factor Pluggable transceiver. These transceivers are fully compliant with FC-P1 and MSA standards and occupy less than half the board space of the existing GBIC products.
<b>Topology</b>	The logical and/or physical arrangement of stations on a network. Fibre Channel topologies include point-to-point, Arbitrated Loop, and switched fabric.
<b>Transceiver</b>	A device that converts one form of signaling to another for both transmission and reception. SFPs and GBICs are transceivers.

# Index

## A

AL\_PA Cross References [69](#)  
AL\_PA zoning [43](#)

## B

Bad Device Recovery policy [34](#)  
Bad Zone Recovery policy [43](#)  
Blocking ARB [23](#)  
Bypass on Clock Delta policy [35](#)  
Bypass on CRC Error policy [34](#)  
Bypass on No Activity policy [34](#)  
Bypass on OS Error policy [34](#)

## C

cascades [44](#)  
    strings [44](#)  
    trees [44](#)  
Change Notification on Insertion policy [33](#)  
Change Notification on Removal policy [33](#)  
change notifications [33](#)  
Clear on Stall policy [34](#)  
CLI  
    commands [66](#)  
    connecting [64](#)  
    frequent tasks [65](#)  
    logging in and out [64](#)  
configuration files [35, 36](#)  
configuring  
    network interface [15](#)  
    Smart Settings [28](#)  
    switch settings [21](#)  
    Web Manager [16](#)  
custom Smart Settings [30](#)  
customer support [1](#)

## D

date and time settings [25](#)  
desktop installation [7](#)  
device prioritization [48](#)  
diagnostics [35](#)  
    port [54](#)  
displaying  
    event log [51](#)  
    ordered sets [56](#)  
    port diagnostics [54](#)  
    port information [52](#)  
    port utilization [53](#)  
    switch status [48](#)  
documentation [17](#)  
downloading firmware [36](#)

## E

ethernet LEDs [9](#)  
event log [51](#)  
event log messages [67](#)

## F

Fabric Connection Smart Setting [29](#)  
features, switch [2](#)  
Fibre Channel references [61](#)  
firmware [35, 36](#)  
    changing versions [36](#)  
    loading [36](#)

## G

glossary [70](#)

## H

hard zoning [42](#)

## I

Initialization Master [38](#)  
Initiator or Target Smart Setting [29](#)  
Initiator with Stealth Smart Setting [29](#)  
InSpeed Technology [3](#)  
installation, switch [6, 7](#)  
    UL guidelines [7](#)  
installing the switch [6](#)  
introduction [1](#)

## J

joining multiple switches [44](#)

## L

LEDs  
    2 Gb/s [9](#)  
    ethernet [9](#)  
    port [10](#)  
    Port Bypassed [10](#)  
    POST Fault [9](#)  
    Power [9](#)  
    power supply/fan module [10](#)  
    SFP Status [10](#)  
    switch [8](#)  
    Switch Operational [9](#)  
    system [9](#)  
load balancing [46](#)  
loading firmware [36](#)  
logging in and out [64](#)  
logging in to the switch [21](#)

## M

managing the switch [20](#)  
monitoring the switch [48](#)

## N

network interface configuration [15](#)  
network settings [22](#)

## O

operating conditions [63](#)  
operating speed [23](#)  
ordered sets [56](#)  
overview [2](#)

## P

password [64](#)  
    changing [26](#)  
policies [32](#), [33](#), [34](#), [35](#)  
    Bad Device Recovery [34](#)  
    Bypass on Clock Delta [35](#)  
    Bypass on CRC Error [34](#)  
    Bypass on No Activity [34](#)  
    Bypass on OS Error [34](#)  
    Change Notification on Insertion [33](#)  
    Change Notification on Removal [33](#)  
    Clear on Stall [34](#)  
    Port Test Before Insert (PTBI) [33](#)

### port

    diagnostics [54](#)  
    hard zoning [42](#)  
    information [52](#)  
    Smart Settings [29](#)  
        assignments [32](#)  
        change notifications [33](#)  
        creating custom [30](#)  
        diagnostics [35](#)  
        Fabric Connection [29](#)  
        Initiator or Target [29](#)  
        Initiator with Stealth [29](#)  
        port information [32](#)  
        port recovery [34](#)  
        pre-insertion testing [32](#)  
        String Cascade [29](#)  
        Target with Stealth [29](#)  
        Tree Cascade [29](#)

    utilization [53](#)

### port bypass [55](#)

    conditions and recovery [59](#)

### port information [32](#)

### port LEDs [10](#)

### port reset [55](#)

### Port Test Before Insert (PTBI) policy [33](#)

### ports

    in multiple zones [40](#)

### power supply/fan module [13](#)

### LED [10](#)

    powering on the switch [12](#)  
    pre-insertion testing [32](#)  
    prioritization of devices [48](#)

## R

rack installation [7](#)  
    UL guidelines [7](#)  
references, Fibre Channel [61](#)

## S

serial interface connection [64](#)  
SFP

    attaching devices [11](#)  
    compatibility [11](#)  
    installation [11](#)  
    removal [11](#)

### shipped contents [6](#)

### Smart Settings [28](#), [29](#), [60](#)

    assignments [32](#)  
    change notifications [33](#)  
    creating [30](#)  
    default [60](#)  
    diagnostics [35](#)  
    Fabric Connection [29](#)  
    Initiator or Target [29](#)  
    Initiator with Stealth [29](#)  
    policies [32](#)  
    port information [32](#)  
    port recovery [34](#)  
    pre-insertion testing [32](#)  
    String Cascade [29](#)  
    Target with Stealth [29](#)  
    Tree Cascade [29](#)

### SNMP traps [24](#)

### speed, operating [23](#)

### String Cascade Smart Setting [29](#)

### string cascades [44](#)

### support, technical [1](#)

### switch

    cascades [44](#)  
    changing the password [26](#)  
    configuration [21](#)  
    configuration files [35](#), [36](#)  
    date and time settings [25](#)  
    default Smart Settings [60](#)  
    event log [51](#)  
    event log messages [67](#)  
    features [2](#)  
    firmware [35](#), [36](#)  
    general settings [22](#)  
    hard zoning [42](#)  
    identification [22](#)  
    initial setup [18](#)

- installation [6, 7](#)
- LEDs [8](#)
- load balancing [46](#)
- management [14, 20](#)
- monitoring [48](#)
- network settings [22](#)
- operating conditions [63](#)
- ordered sets [56](#)
- overview [2](#)
- package contents [6](#)
- policies [32, 33, 34, 35](#)
- port diagnostics [54](#)
- port information [52](#)
- port utilization [53](#)
- powering on [12](#)
- settings [21](#)
- specifications [63](#)
- speed [23](#)
- status [48](#)
- telnet session [26](#)
- thresholds [27](#)
- trunking [45](#)
- unpacking [6](#)
- version [23](#)
- Web Manager login [21](#)
- zoning [37, 39, 40, 41](#)

system LEDs [9](#)

## T

- Target with Stealth Smart Setting [29](#)
- technical support [1](#)
- telnet session [26](#)
- temperature [63](#)
- terms
  - see glossary [70](#)
- thresholds [27](#)
- time and date settings [25](#)
- traps [24](#)
- Tree Cascade Smart Setting [29](#)
- tree cascades [44](#)
- troubleshooting [58](#)
- trunking [45](#)

## U

- UL guidelines [7](#)
- unpacking the switch [6](#)

## V

- version information [23](#)
- viewing
  - event log [51](#)
  - ordered sets [56](#)
  - port diagnostics [54](#)
  - port information [52](#)
  - port utilization [53](#)

- switch status [48](#)

## W

- Web Manager [14](#)
  - agent up time [23](#)
  - automatic trunking [45](#)
  - Bad Zone Recovery [43](#)
  - configuration [16](#)
  - configuration files [35, 36](#)
  - event log [51](#)
  - firmware [35, 36](#)
  - getting started [15](#)
  - hard zoning [42](#)
  - initial switch setup [18](#)
  - load balancing [46](#)
  - loading firmware [36](#)
  - network location [22](#)
  - network settings [22](#)
  - opening a telnet session [26](#)
  - ordered sets [56](#)
  - overview [16](#)
  - password [26](#)
  - port diagnostics [54](#)
  - port information [52](#)
  - port utilization [53](#)
  - Smart Settings [28](#)
  - SNMP traps [24](#)
  - switch identification [22](#)
  - switch login [21](#)
  - switch speed [23](#)
  - switch status [48](#)
  - switch thresholds [27](#)
  - switch version [23](#)
  - time settings [25](#)
  - zoning [37, 39, 40, 41](#)

## Z

- Zone Initialization Master [38](#)
- zoning [37](#)
  - bad zone recovery [43](#)
  - hard zoning [42](#)
  - Initialization Master [38](#)
  - multiple switches [41](#)
  - ports in multiple zones [40](#)
  - single switch [39](#)
  - using AL\_PAs [43](#)