



SERVICE MANUAL



INTRODUCTION

Welcome to your new Bailey Caravan.

This service manual has been designed to enable you to derive the maximum benefits and enjoyment from your vehicle and the information contained will be of benefit to both experienced and new caravan owners alike.

It should be used in conjunction with the Caravan Owner's manual located at the reverse of this book.

Your caravan is designed to give you many years of use, regular maintenance is however necessary to ensure trouble free service. Your Bailey Retailer is equipped to offer service and repair work facilities as well as supplying any spare parts or accessories you may require. All enquiries regarding your caravan should therefore be addressed in the first instance to the Retailer from whom the vehicle was purchased.

Unicorn Warranty Cover

Total customer satisfaction is top priority at Bailey and the quality ethos extends to the after sales service and market leading manufacturer's warranty package that comes with every new Bailey Unicorn caravan. In this way we not only ensure long-term peace of mind but also enhance the re-sale value of your investment.

6 Year Body Shell Integrity Guarantee

The Bailey Alu-Tech Unicorn caravan is covered by a six (6) year Bodyshell Integrity Guarantee from the initial date of purchase. This cover extends to any structural degradation to the bodyshell that arises as a result of water ingress through any permanently sealed seams or joints (with the

exception of exclusions stated in the terms and conditions.)

Warranty Extension

An additional four (4) year extension to the standard Bodyshell Integrity Warranty cover (making 10 years cover in total) is available as a cost option. Please ask your supplying Bailey Retailer for more information.

3 Year Manufacturer's Warranty

For a period of twenty-four (24) months from the initial date of purchase Bailey of Bristol offer a comprehensive warranty on all parts and components as well as full coverage for any manufacturing faults forming part of the original specification of the vehicle. The manufacturer's warranty then extends to an additional twelve (12) months on the following items

Chassis: all chassis members including corner steadies

Suspension: axle suspension and braking system (excluding any damage to or faults in brake drums and shoes that are caused through misuse of the braking system or from normal wear and tear)

Running Gear: road wheels (excluding tyres)

Towing Mechanism: all mechanical components fitted to vehicle (excluding electrics)

Cooker: the cooker unit including burners, grill, oven, hot plate, flame failure device and igniter

Refrigerator: door seal condenser, gas control valve, gas igniter, flame failure device, 230v heater elements, gas thermostat, thermostat and temperature control switch
Water System: water heater (gas or electric), fresh water tank, water pump, water gauges,

taps and shower head

Electrical System: mains hook up input connector, ELCB, and interior lighting units (excluding bulbs and LED's)

Cassette Toilet: the cassette toilet is covered (excluding seals, valves and glands)

Heating System: thermostat, motor, switches, control unit, gas heater, flame failure device and igniter (excluding ducting and fittings)

Windows: the functionality of the opening and closing system (stays, handles and catches).

Upholstery: zips, seams and colour fastness

Warranty Extension

An additional three (3) year extension to the standard Manufacturer's Warranty cover for mechanical and electrical components of a leisure vehicle both external and internal (making 6 years cover in total) is available as a cost option. Please ask your supplying Bailey Retailer for more information.

Customer Support

In the unusual event of something going wrong your first contact should always be your supplying retailer. Approved Bailey Retailers enjoy industry-leading after sales support service from the manufacturer and they should be able to offer all the help you need to rectify any problems that may exist.

Terms and Conditions

The Bailey Warranty Cover set out above is offered subject to the following simple terms and conditions:

Cover

1. During the term of the Warranty Cover, subject to these terms and conditions, Bailey

will, through an Authorised Service Centre, at its option repair or replace all parts and components of the Unicorn caravan that are included in the Warranty Cover and which suffer a defect in manufacture or workmanship. An Authorised Service Centre means either Bailey itself, a Bailey Approved Retailer or a Bailey Approved Service Centre. Any part which is replaced becomes the property of Bailey. Any replacement parts are covered for the unexpired term of the Warranty Cover.

Term

2. The initial duration of the Bodyshell Integrity Guarantee is six (6) years and the duration of the Manufacturer's Warranty is three (3) years in both cases starting from the original purchase date of the vehicle. It is a condition of the warranty that an annual service is performed on the vehicle in accordance with the service plan. Failure to comply with this term will invalidate the warranty.

3. The unexpired term of the Warranty Cover on your vehicle may only be assigned, transferred or novated to subsequent owners with Bailey's consent (not to be unreasonably withheld) and on payment to Bailey of a transfer fee of £35. Transfer can only be made within the first three months (3) of subsequent ownership and full documentary evidence that the vehicle has been serviced annually must be provided at the time of assignment in accordance with the terms and conditions detailed above.

Repairs

4. The Unicorn caravan must undergo a full annual service and inspection, including

a moisture survey, carried out, subject to paragraph 5 below, by an Authorised Service Centre. The final annual service in the warranty period must be carried out before the end of that warranty period, but all other annual services may be carried out within six (6) weeks either side of each anniversary of the original purchase date. The original VAT invoices must be retained as proof that these annual inspections have been carried out.

5. During the first three (3) years of the Warranty Cover, all annual inspections and repairs must be carried out either by Bailey itself or an approved Bailey Service Centre or Agent. Thereafter, due to the technical nature of an Alu-Tech constructed caravan, annual inspections and repairs may be carried out by any workshop or repair centre approved by the National Caravan Council that has attended Alu-Tech training courses at the Bailey factory.

6. Where an annual inspection identifies that repairs to the vehicle are necessary, the Unicorn caravan must be made available for repair within six (6) weeks of the date of inspection for the purpose of carrying out the repair work.

7. No repairs, including the fitting of any replacement unit, may be undertaken or commenced under the terms of the Warranty Cover unless prior written authorisation is obtained from Bailey via an authorised Bailey Retailer or Service Centre. No liability will exist with regard to any warranty claims not authorised in this way.

8. Bailey reserve the right to examine the vehicle before any repairs commence or any replacement part is fitted.

Registration & Use

9. The Warranty Registration Form must have been sent to Bailey within six (6) weeks of the original purchase date. It is the responsibility of the Bailey Retailer to forward this information to Bailey. This is part of the terms of trading that the Bailey Retailer has with Bailey.

10. The Unicorn caravan shall:

- (a) only be used for its ordinary and intended purpose and shall not be subjected to any treatment or conditions which could reasonably be foreseen to cause or result in damage to the vehicle or excessive wear and tear;
- (b) only be towed by a private car or private 4 x 4 vehicle; and
- (c) not be put out to hire, reward or any other commercial use, nor used in any race, competitions or rallies whether timed, official or otherwise.

Exclusions & Liability

11. Bailey's liability under this warranty shall be limited to supplying the reasonable costs of labour and materials required for the repair or replacement of faulty parts or components. Bailey shall be entitled to charge for any repair work which is necessitated by virtue of any loss or damage caused by your negligence or default or incurred as a result of any modifications you have made to the vehicle. This warranty does not cover repair costs other than labour and materials.

12. The Warranty Cover does not include:

- (a) repair or replacement of parts, components, seams or panels which are not part of the original construction of the Unicorn caravan, or which have been tampered with or undergone unauthorised modifications, or

which have been repaired otherwise than by an Authorised Service Centre;

(b) parts or components other than those specifically listed in the Bodyshell Integrity Guarantee and Manufacturer's Warranty descriptions set out above;

(c) general maintenance or components failing due to fair wear and tear or normal deterioration;

(d) repairs necessitated by lack of routine or regular maintenance. Particular attention is drawn to the Owner's Manual and Service Handbook supplied with the caravan and any maintenance instructions or notices published from time to time by Bailey relating to the proper care and maintenance of vehicles; or

(e) structural degradation or other damage caused by water ingress through non-permanently sealed seams or joints (such as, without limitation, around windows, hatches, doors and rooflights), beyond the initial 24 months of the Manufacturer's Warranty.

13. No liability will be accepted for:

(a) damage caused by neglect or abuse, corrosion, intrusion of foreign or deleterious substances, lack of servicing, over-heating, freezing, or the continued use of the vehicle after a fault has become evident;

(b) any loss or damage caused by parts not covered by this Warranty Cover, including soft furnishings or trim;

(c) any accidental or fire damage or any losses incurred by accident or fire; or

(d) transport costs to and from point of repair.

14. Bailey will only be liable for costs which are incurred as a direct consequence of the event, defect or fault leading to the claim being made under this warranty. No liability will be accepted for any other loss or damage (such as loss of income or revenue, or loss of

business or profits), costs, expenses or other claims for compensation howsoever arising which was not reasonably foreseeable by both parties when the caravan was originally purchased. Bailey will not be liable for any loss or damage suffered by third parties, nor for bodily injury not caused by our negligence.

15. Nothing in this warranty shall limit in any way our liability: for death or personal injury caused by our negligence; for fraud or fraudulent misrepresentation; or for any matter for which it would be illegal for us to exclude, or attempt to exclude, our liability.

16. The purchaser has statutory rights in addition to this warranty and this warranty does not affect those statutory rights.

17. This warranty shall be governed by and construed in accordance with the laws of England and the parties irrevocably submit to the non-exclusive jurisdiction of the courts of England.

The name and address of the warranty and guarantee provider is:
Bailey Caravans Limited, South Liberty Lane,
Bristol, BS3 2SS

Warranty Registration

The supplying retailer must explain the warranty terms and conditions to you, and complete the warranty registration process on-line. Your warranty will start on the day that the vehicle is first registered in the UK or 12 months from the date of which the vehicle was invoiced to the supplying retailer whichever is the earlier.

Please sign below to verify that this has been explained to you:

Customer's signature:

Date:.....

Retailer's Signaure:.....

Date:.....



SCHEDULED SERVICE TYPE	SERVICE AGENT	DEALER STAMP	TECHNICIAN'S NAME	DATE
Bailey Pre delivery Inspection				
1st year service (necessary to ensure warranty cover in the 2nd year)				
2nd year service (necessary to ensure warranty cover in the 3rd year)				
3rd year service (necessary to ensure warranty cover in the 4th year)				
4th year service (necessary to ensure warranty cover in the 5th year)				
5th year service (necessary to ensure warranty cover in the 6th year)				
6th year service (necessary to ensure warranty cover in the 7th year)				

7th year service (necessary to ensure warranty cover in the 8th year)				
8th year service (necessary to ensure warranty cover in the 9th year)				
9th year service (necessary to ensure warranty cover in the 10th year)				
10th year service				
11th year service				
12th year service				
13th year service				

Unicorn 2	Seville	Madrid	Valencia	Cadiz	Barcelona
Berths	2	4	4	4	4
Axles	1	1	1	1	2
Shipping Length	6424mm	7097mm	7341mm	7341mm	7891mm
Internal Length (Bed box Height)	4765mm	5438mm	5682mm	5682mm	6232mm
Overall width	2280mm	2280mm	2280mm	2280mm	2280mm
Overall Height (incl aerial)	2610mm	2610mm	2610mm	2610mm	2610mm
Maximum Headroom	1960mm	1960mm	1960mm	1960mm	1960mm
Body Length (excluding hitch)	5504mm	6177mm	6421mm	6421mm	6971mm
Tyre Sizes	185/R14 102R	185/R14 102R	185/R14 102R	185/R14 102R	185/65 R14 86T
Awning Dimension	953mm	1020mm	1045mm	1045mm	1093mm
Tyre Pressure (PSI/Bar)	60Psi	60Psi	60Psi	60Psi	35Psi
MRO	1225Kg	1329Kg	1343Kg	1344Kg	1526Kg
MTPLM (Standard)	1350Kg	1484Kg	1497Kg	1498Kg	1686Kg
Opt Equipment Payload	3Kg	3Kg	3Kg	3Kg	3Kg
Total User Payload	125Kg	155Kg	154Kg	154Kg	160Kg
Static Load on Coupling Head	100Kg	100Kg	100Kg	100Kg	100Kg
Wheel bolt Torque	130 Nm	130Nm	130Nm	130Nm	130Nm

Pegasus GT65	Genoa	Ancona	Verona	Rimini	Bologna
Berths	2	6	4	4	4
Axles	1	1	1	1	2
Shipping Length	6293mm	7378mm	7378mm	7400mm	7935mm
Internal Length (Bed box Height)	4629mm	5682mm	5682mm	5710mm	6232mm
Overall width	2230mm	2230mm	2230mm	2230mm	2230mm
Overall Height (incl aerial)	2610mm	2610mm	2610mm	2610mm	2610mm
Maximum Headroom	1950mm	1950mm	1950mm	1950mm	1950mm
Body Length (excluding hitch)	5338mm	6391mm	6391mm	6419mm	6941mm
Tyre Sizes	185/R14 102R	185/R14 102R	185/R14 102R	185/R14 102R	185/65 R14 86T
Awning Dimension	940	1045	1045	1048	1093
Tyre Pressure (PSI/Bar)	60/4.2	60/4.2	60/4.2	60/4.2	35/2.45
MRO	1159Kg	1327Kg	1290Kg	1314Kg	1443Kg
MTPLM (Standard)	1287Kg	1497Kg	1440Kg	1464Kg	1598Kg
Opt Equipment Payload	3Kg	3Kg	3Kg	3Kg	3Kg
Total User Payload	128Kg	170Kg	150Kg	150Kg	155Kg
Maximum Static Load on Coupling Head	100Kg	100Kg	100Kg	100Kg	100Kg
Wheel bolt Torque	130Nm	130Nm	130Nm	130Nm	130Nm



From the 2011 season the method of calculating the Mass in Running order (MRO) and user payload figures has changed in order to bring it in line with European Vehicle Directives.

Allowances for essential equipment (e.g. gas cylinders) previously allowed for in the user payload are now contained with the MRO. A provision for a leisure battery which used to be within the essential equipment payload allowance.

Although the method of calculation has changed, the overall effect is that the amount of payload available to the customer has remained the same; it is just calculated in another manner.

Awning sizes are ground to ground dimensions through the awning channel. These dimensions are issued as a guideline only; please refer to your dealer for the correct awning size to suit your particular caravan.

Unicorn Bed Sizes	Seville	Madrid	Valencia	Cadiz	Barcelona
Front Double	6'9" x 5'7"	6'9" x 5'6"	6'9" x 4'8"	6'9" x 4'8"	6'9" x 5'3"
Or Front Nearside Single and Front Offside Single	6'6" x 2'4"	6'1" x 2'4"	5'9" x 2'4"	5'5" x 2'4"	5'9" x 2'4"
Fixed Bed					
Rear Double			6'3" x 4'4"		6'3" x 4'4"
Rear Offside Single				6'5" x 2'2"	
Rear Nearside Single				6'0" x 2'2"	
Side Dinette		6'3" x 1'11"			
Side Dinette Bunk		6'3" x 1'10"			

Pegasus GT65 Bed Sizes	Genoa	Ancona	Verona	Rimini	Bologna
Front Double	6'8" x 5'9"	6'8" x 5'4"	6'8" x 4'9"	6'8" x 4'9"	6'8" x 5'4"
Or Front Nearside Single and Front Offside Single	6'1" x 2'5"	5'7" x 2'5"	5'8" x 2'5"	5'8" x 2'5"	5'8" x 2'5"
Fixed Bed			6'2" x 4'3"		6'2" x 4'3"
Rear Offside Single				6'3" x 2'3"	
Rear Nearside Single				6'0" x 2'3"	
Side Dinette		5'7" x 2'1"			
Side Dinette Bunk		5'5" x 2'1"			
Lower Bunk		6'0" x 2'0"			
Upper Bunk		6'0" x 2'0"			



All dimensions are approximate due to slight variations in suspension heights, loading conditions and tyre pressures. Customers should verify the actual dimensions of their touring caravan before committing to anything that could be impacted by these dimensions. Any dealer fit options will reduce the overall payload available to the user of the caravan.



If you require additional payload it is possible to upgrade the MTPLM on some vehicles. Please contact your Bailey caravan dealer for more information.

Fuse MCB Specifications Chart

Fuses		
Alarm	5 amp (yellow)	Pump
Fridge Ignition	5 amp (yellow)	Aux Socket
Caravan Battery	15 amp (blue)	Radio/Aerial
Fridge Ignition	15 amp (blue)	Alde Water heater
Caravan Batttery	15 amp (blue)	Alde central Heating
Lights 1	15 amp (blue)	Refrigerator
Lights 2	15 amp (blue)	Smoke Alarm Battery
Ignitions	5 amp (yellow)	CO alarm Battery
		PIR alarm Battery

Road Lights	Bulb Type	Bulb Rating
Front Marker Lights	LED	12v/ <1 watt
Side Marker Lights (Low Level)	LED	12v/ <1 watt
Side Marker Lights (High Level)	R5W	12v/ 5 watt
Brake Light (High Level)	LED	12v/ <1 watt
Number Plate Light	Festoon	12v/ 10 watt
Tail Light	R10	12v/ 10 watt
Direction Indicator Light	PY21	12v/ 21 watt
Reversing Light	P21	12v/ 21 watt
Brake Light (Low Level)	P21	12v/ 21 watt
Fog Light	P21	12v/ 21 watt

Bulb Replacement

Unicorn Tail, Indicator, reverse, brake and fog.

1. Remove the 2 fixing screws whilst supporting the rear light. Keep the screws safely, ready for refitting the light. Do not attempt to use any alternative screws which could damage the rear light or caravan panel.
2. Pull the rear light towards you from the side with the fixing holes. This will release the 2-hooks which locate into the caravan panel and will allow you to see the back of

the rear light.

3. Remove the bulb holder with the failed bulb from the rear light by turning the bulb holder anti-clockwise, remove the failed bulb from the bulb holder and fit the correct replacement. There is a diagram on the lower part of the light which shows the bulb type to be fitted. Replace the bulb holder by inserting into the hole and turn clockwise to lock into position. Ensure all seals are correctly located.
4. Offer the rear light back into the caravan panel, ensure the 2-location hooks are

engaged and then replace the rear light fixing screws.



Do not over tighten! Maximum torque is 80 Ncm

5. Check for correct operation of all light functions.

Pegasus GT65 Tail, Indicator, reverse, Brake and Fog.

1. Using a Pozi-Drive screwdriver remove carefully the screws visible on the failed lamps lens, support the lens so it cannot fall.

Function dependant

2. For the Indicator bulb remove the bulb by turning anticlockwise with slight pressure on the bulb.
3. Replace Bulb with a new 12V 21W Clear Bulb aligning the pins correctly prior to installation. Install new bulb with slight pressure and turn clockwise.
4. For the Stop Tail bulb remove the bulb by turning anticlockwise with slight pressure on the bulb.
5. Replace Bulb with a new 12V 21/5W Clear Bulb aligning the pins correctly prior to installation. Install new bulb with slight pressure and turn clockwise.
6. For the Fog bulb remove the bulb by turning anticlockwise with slight pressure on the bulb.
7. Replace Bulb with a new 12V 21W Clear Bulb aligning the pins correctly prior to installation. Install new bulb with slight pressure and turn clockwise.
8. For the Reverse bulb remove the bulb by turning anticlockwise with slight pressure

on the bulb.

9 Replace Bulb with a new 12V 21W Clear Bulb aligning the pins correctly prior to installation. Install new bulb with slight pressure and turn clockwise.

Upper Side position lamps

1. Remove lens from base to access bulb.
2. Carefully insert small flat head screwdriver into the recess in the lower edge of the lamp base. Apply pressure to the locking base.
3. Lift lens upwards and away from the lamp base, lower edge first.
4. Lever the bulb from the retaining clips
5. Reverse procedure to re-fit bulb and lens.

High level Brake light, Number plate lights, side marker lights (low level) and front marker lights

1. Remove 2 screws from the face of the lamp
2. Withdraw the whole fitting away from the caravan panel.
3. Disconnect the lamp from the harness.
4. Re-connect the new lamp to the harness, and secure the lamp to the caravan body with 2 screws.

Interior/Other lights	Bulb Type	Bulb Rating
Awning Light	LED	12v/ < 1watt
Locker Spotlights	LED	12v/ < 1watt
Recessed Downlighters	LED	12v/ < 1watt
CIRO ceiling light	G4	12v/ 2 x 10 watt

Note: Not all bulbs and lights feature on all models within a range.

Service Schedule

In order to validate the factory backed warranty package, your caravan must be serviced by an approved Bailey Service centre every 12 months (or within 6 weeks of each anniversary of purchase) in accordance with the NCC recommended service schedule.

A full listing of the current Approved Bailey Centres can be found on the Retailer Network pages of our website @www.bailey-caravans.co.uk.

In no circumstances should the body shell fixings be tampered with or adjusted by the caravan owner. In instances where this has occurred the warranty will be automatically invalidated.



Standard Moisture survey for Alu-tech construction caravans.

The following moisture survey must be carried out using a calibrated moisture meter every 12 months by an Approved Bailey Service Centre.

Readings should be taken on the floor section of the motorhome in positions where the holes created by the meter's probes are not visible i.e. behind seals, in bed boxes or in cupboard bases. It is important to make sure that the

probes are free from moisture and the surface of the floor is free from condensation. Readings below 20% are considered acceptable. Readings greater than 20% will identify areas that need further investigation and possible remedial work. All other parts of the Alu-Tech caravan should be checked visually for moisture ingress.

Thermal Insulation Grade

All Alu-Tech Bailey Caravans are manufactured and approved by the NCC to EN1645 thermal grade III. This has been approved using the caravan heating system on both electric and gas.

Grade III is classified as being able to achieve an average temperature difference of 35 degrees centigrade between inside the caravan and outside when the exterior temperature is -15 degrees.

2013 BAILEY UNICORN II CIRCUIT DIAGRAM

DRAWING TEMPLATE-A CF04
ISSUE DATE 22/02/2010 ISSU

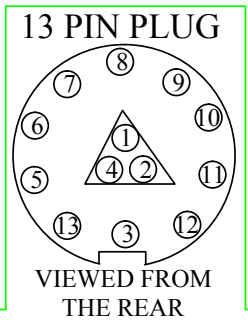
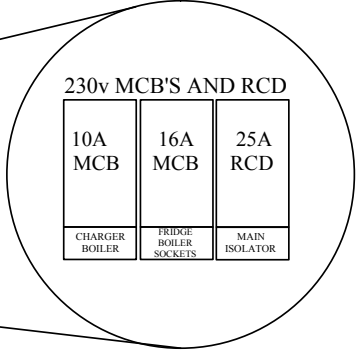
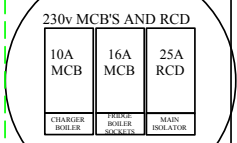
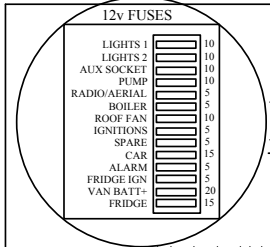
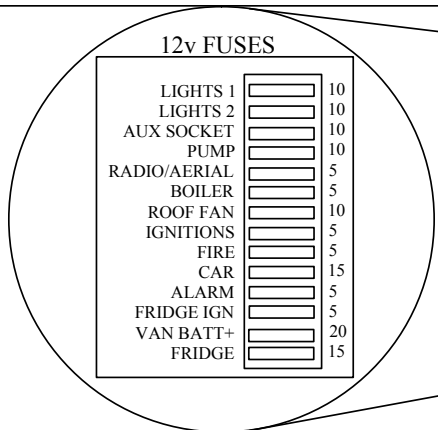
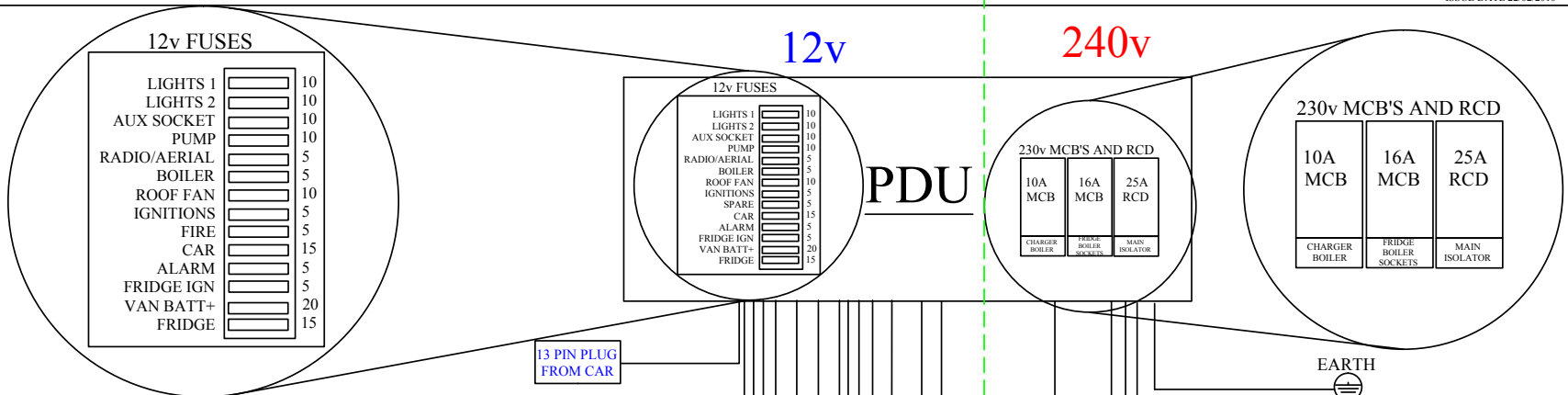

1. LEFT INDICATOR	1.5mm	YELLOW
2. FOG LIGHT	1.5mm	BLUE
3. EARTH	2.5mm	WHITE
4. RIGHT INDICATOR	1.5mm	GREEN
5. RIGHT TAIL/SIDE LIGHT	1.5mm	BROWN
6. BRAKE LIGHT	1.5mm	RED
7. LEFT TAIL/SIDE LIGHT	1.5mm	BLACK
8. REVERSE LIGHT	1.5mm	ORANGE
9. 12v PERMANENT	2.5mm	BLUE/BROWN
10. 12v IGNITION FEED	2.5mm	RED/BROWN
11. EARTH FOR POSITION 10	2.5mm	GREEN/WHITE
12. UNUSED		
13. EARTH FOR POSITION 9	2.5mm	BLUE/WHITE

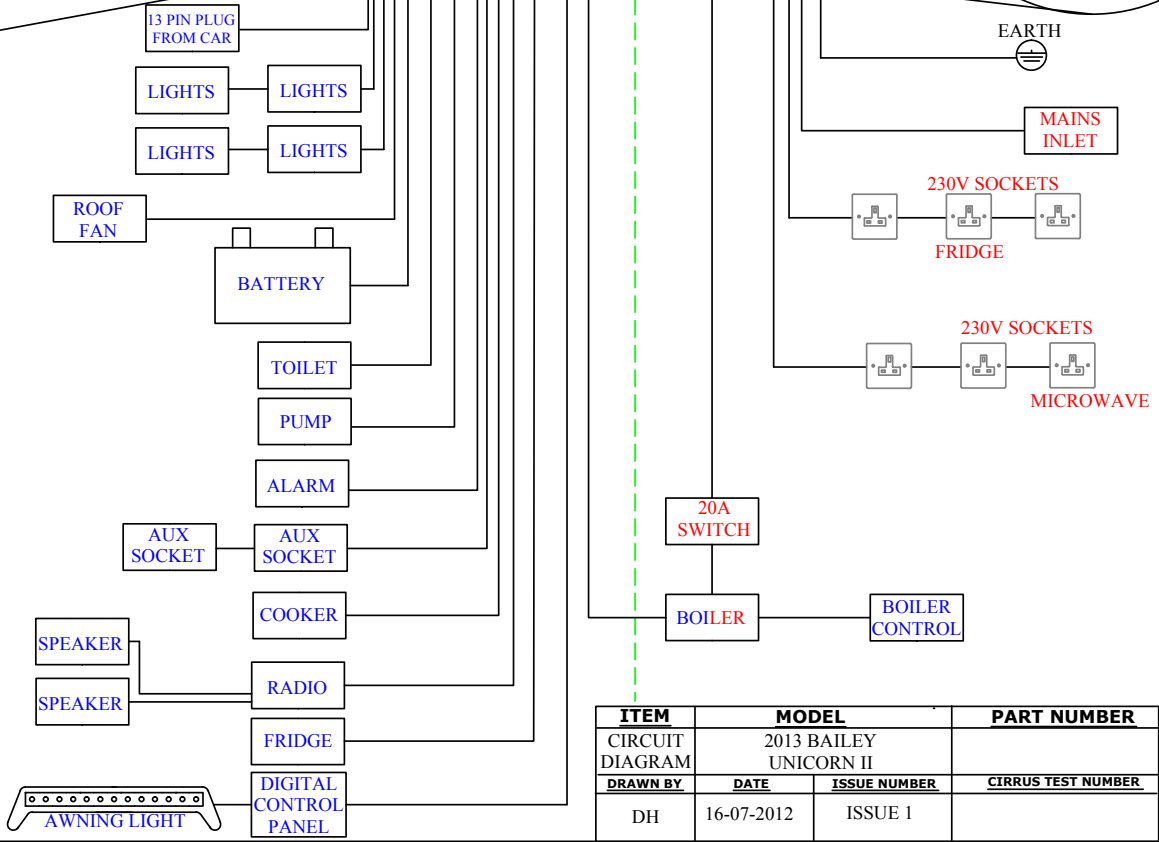

ITEM	MODEL	PART NUMBER	
CIRCUIT DIAGRAM	2013 BAILEY UNICORN II		
<u>DRAWN BY</u>	<u>DATE</u>	<u>ISSUE NUMBER</u>	<u>CIRRUS TEST NUMBER</u>
DH	16-07-2012	ISSUE 1	



2013 BAILEY PEGASUS GT65 CIRCUIT DIAGRAM

DRAWING TEMPLATE-A CF048
ISSUE DATE 22/02/2010 ISSUE 1

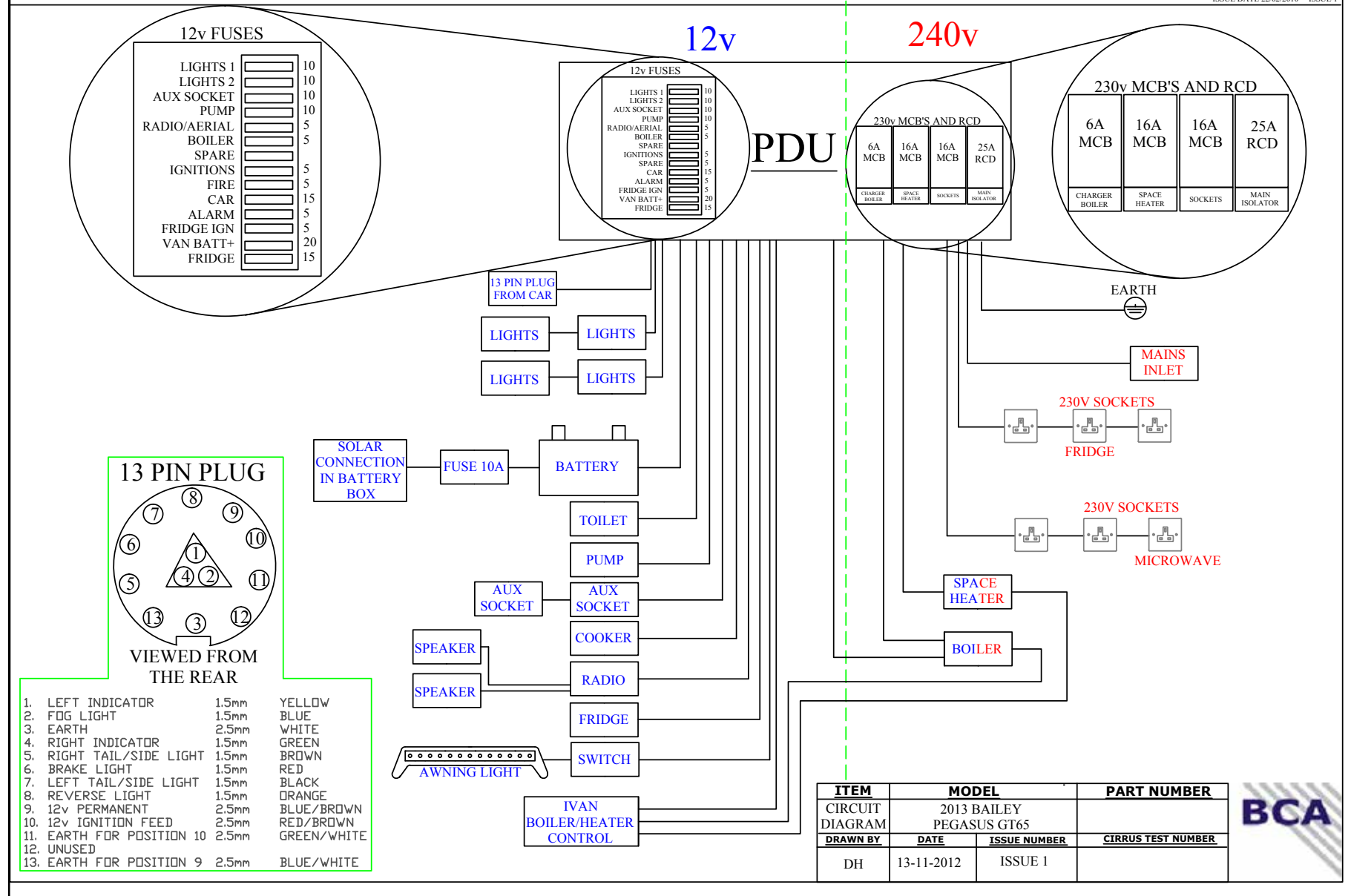

ITEM	MODEL	PART NUMBER
CIRCUIT DIAGRAM	2013 BAILEY PEGASUS GT65	
<u>DRAWN BY</u>	<u>DATE</u>	<u>ISSUE NUMBER</u>
DH	13-11-2012	ISSUE 1
		<u>CIRRUS TEST NUMBER</u>

If the caravan is sold before the end of the original warranty the remaining period can be transferred to the new owner using the warranty transfer form. There is a fee charged for this service of £35 incl VAT.

Please send a copy of the Service handbook and your CRiS document along with this sheet and a copy of the service sheets from this service guide along with a cheque for £35 to Bailey of Bristol, South Liberty Lane, Bristol, BS3 2SS. Please make your cheque payable to "Bailey Caravans Ltd" We are unable to accept any other form of payment.

In order for the warranty to remain valid the caravan must have been serviced annually by an authorised Bailey Service Centre prior to the transfer of ownership, failure to do so will invalidate any further warranty cover.

Failure to request this transfer within 14 days of acquisition by the new owner will invalidate the remaining warranty.

Terms and Conditions apply.

MODEL	_____
VIN NUMBER	_____
PURCHASE DATE	_____
PREVIOUS OWNER	_____
NEW OWNER	_____
NEW OWNER'S ADDRESS	_____ _____
NEW OWNER'S TELEPHONE NUMBER	_____
NEW OWNER'S EMAIL ADDRESS	_____
I have read and understood the terms and conditions of the warranty, including the servicing requirements, as applicable to this vehicle.	
Signed: _____	Date: _____



PAGE LEFT BLANK INTENTIONALLY

If the caravan is sold before the end of the original warranty the remaining period can be transferred to the new owner using the warranty transfer form. There is a fee charged for this service of £35 incl VAT.

Please send a copy of the Service handbook and your CRiS document along with this sheet and a copy of the service sheets from this service guide along with a cheque for £35 to Bailey of Bristol, South Liberty Lane, Bristol, BS3 2SS. Please make your cheque payable to "Bailey Caravans Ltd" We are unable to accept any other form of payment.

In order for the warranty to remain valid the caravan must have been serviced annually by an authorised Bailey Service Centre prior to the transfer of ownership, failure to do so will invalidate any further warranty cover.

Failure to request this transfer within 14 days of acquisition by the new owner will invalidate the remaining warranty.

Terms and Conditions apply.

MODEL	_____
VIN NUMBER	_____
PURCHASE DATE	_____
PREVIOUS OWNER	_____
NEW OWNER	_____
NEW OWNER'S ADDRESS	_____ _____ _____
NEW OWNER'S TELEPHONE NUMBER	_____
NEW OWNER'S EMAIL ADDRESS	_____
I have read and understood the terms and conditions of the warranty, including the servicing requirements, as applicable to this vehicle.	
Signed:	_____ Date: _____



PAGE LEFT BLANK INTENTIONALLY

If the caravan is sold before the end of the original warranty the remaining period can be transferred to the new owner using the warranty transfer form. There is a fee charged for this service of £35 incl VAT.

Please send a copy of the Service handbook and your CRiS document along with this sheet and a copy of the service sheets from this service guide along with a cheque for £35 to Bailey of Bristol, South Liberty Lane, Bristol, BS3 2SS. Please make your cheque payable to "Bailey Caravans Ltd" We are unable to accept any other form of payment.

In order for the warranty to remain valid the caravan must have been serviced annually by an authorised Bailey Service Centre prior to the transfer of ownership, failure to do so will invalidate any further warranty cover.

Failure to request this transfer within 14 days of aquisition by the new owner will invalidate the remaining warranty.

Terms and Conditions apply.

MODEL	_____
VIN NUMBER	_____
PURCHASE DATE	_____
PREVIOUS OWNER	_____
NEW OWNER	_____
NEW OWNER'S ADDRESS	_____ _____ _____
NEW OWNER'S TELEPHONE NUMBER	_____
NEW OWNER'S EMAIL ADDRESS	_____
I have read and understood the terms and conditions of the warranty, including the servicing requirements, as applicable to this vehicle.	
Signed:	_____ Date: _____



PAGE LEFT BLANK INTENTIONALLY

If the caravan is sold before the end of the original warranty the remaining period can be transferred to the new owner using the warranty transfer form. There is a fee charged for this service of £35 incl VAT.

Please send a copy of the Service handbook and your CRiS document along with this sheet and a copy of the service sheets from this service guide along with a cheque for £35 to Bailey of Bristol, South Liberty Lane, Bristol, BS3 2SS. Please make your cheque payable to "Bailey Caravans Ltd" We are unable to accept any other form of payment.

In order for the warranty to remain valid the caravan must have been serviced annually by an authorised Bailey Service Centre prior to the transfer of ownership, failure to do so will invalidate any further warranty cover.

Failure to request this transfer within 14 days of aquisition by the new owner will invalidate the remaining warranty.

Terms and Conditions apply.

MODEL	_____
VIN NUMBER	_____
PURCHASE DATE	_____
PREVIOUS OWNER	_____
NEW OWNER	_____
NEW OWNER'S ADDRESS	_____ _____ _____
NEW OWNER'S TELEPHONE NUMBER	_____
NEW OWNER'S EMAIL ADDRESS	_____
I have read and understood the terms and conditions of the warranty, including the servicing requirements, as applicable to this vehicle.	
Signed:	_____ Date: _____



PAGE LEFT BLANK INTENTIONALLY

If the caravan is sold before the end of the original warranty the remaining period can be transferred to the new owner using the warranty transfer form. There is a fee charged for this service of £35 incl VAT.

Please send a copy of the Service handbook and your CRiS document along with this sheet and a copy of the service sheets from this service guide along with a cheque for £35 to Bailey of Bristol, South Liberty Lane, Bristol, BS3 2SS. Please make your cheque payable to "Bailey Caravans Ltd" We are unable to accept any other form of payment.

In order for the warranty to remain valid the caravan must have been serviced annually by an authorised Bailey Service Centre prior to the transfer of ownership, failure to do so will invalidate any further warranty cover.

Failure to request this transfer within 14 days of acquisition by the new owner will invalidate the remaining warranty.

Terms and Conditions apply.

MODEL	_____
VIN NUMBER	_____
PURCHASE DATE	_____
PREVIOUS OWNER	_____
NEW OWNER	_____
NEW OWNER'S ADDRESS	_____ _____ _____
NEW OWNER'S TELEPHONE NUMBER	_____
NEW OWNER'S EMAIL ADDRESS	_____
I have read and understood the terms and conditions of the warranty, including the servicing requirements, as applicable to this vehicle.	
Signed:	_____ Date: _____



PAGE LEFT BLANK INTENTIONALLY

If the caravan is sold before the end of the original warranty the remaining period can be transferred to the new owner using the warranty transfer form. There is a fee charged for this service of £35 incl VAT.

Please send a copy of the Service handbook and your CRiS document along with this sheet and a copy of the service sheets from this service guide along with a cheque for £35 to Bailey of Bristol, South Liberty Lane, Bristol, BS3 2SS. Please make your cheque payable to "Bailey Caravans Ltd" We are unable to accept any other form of payment.

In order for the warranty to remain valid the caravan must have been serviced annually by an authorised Bailey Service Centre prior to the transfer of ownership, failure to do so will invalidate any further warranty cover.

Failure to request this transfer within 14 days of acquisition by the new owner will invalidate the remaining warranty.

Terms and Conditions apply.

MODEL	_____
VIN NUMBER	_____
PURCHASE DATE	_____
PREVIOUS OWNER	_____
NEW OWNER	_____
NEW OWNER'S ADDRESS	_____ _____
NEW OWNER'S TELEPHONE NUMBER	_____
NEW OWNER'S EMAIL ADDRESS	_____
I have read and understood the terms and conditions of the warranty, including the servicing requirements, as applicable to this vehicle.	
Signed: _____	Date: _____



PAGE LEFT BLANK INTENTIONALLY

If the caravan is sold before the end of the original warranty the remaining period can be transferred to the new owner using the warranty transfer form. There is a fee charged for this service of £35 incl VAT.

Please send a copy of the Service handbook and your CRiS document along with this sheet and a copy of the service sheets from this service guide along with a cheque for £35 to Bailey of Bristol, South Liberty Lane, Bristol, BS3 2SS. Please make your cheque payable to "Bailey Caravans Ltd" We are unable to accept any other form of payment.

In order for the warranty to remain valid the caravan must have been serviced annually by an authorised Bailey Service Centre prior to the transfer of ownership, failure to do so will invalidate any further warranty cover.

Failure to request this transfer within 14 days of acquisition by the new owner will invalidate the remaining warranty.

Terms and Conditions apply.

MODEL	_____
VIN NUMBER	_____
PURCHASE DATE	_____
PREVIOUS OWNER	_____
NEW OWNER	_____
NEW OWNER'S ADDRESS	_____ _____
NEW OWNER'S TELEPHONE NUMBER	_____
NEW OWNER'S EMAIL ADDRESS	_____
I have read and understood the terms and conditions of the warranty, including the servicing requirements, as applicable to this vehicle.	
Signed: _____	Date: _____



PAGE LEFT BLANK INTENTIONALLY

If the caravan is sold before the end of the original warranty the remaining period can be transferred to the new owner using the warranty transfer form. There is a fee charged for this service of £35 incl VAT.

Please send a copy of the Service handbook and your CRiS document along with this sheet and a copy of the service sheets from this service guide along with a cheque for £35 to Bailey of Bristol, South Liberty Lane, Bristol, BS3 2SS. Please make your cheque payable to "Bailey Caravans Ltd" We are unable to accept any other form of payment.

In order for the warranty to remain valid the caravan must have been serviced annually by an authorised Bailey Service Centre prior to the transfer of ownership, failure to do so will invalidate any further warranty cover.

Failure to request this transfer within 14 days of acquisition by the new owner will invalidate the remaining warranty.

Terms and Conditions apply.

MODEL	_____
VIN NUMBER	_____
PURCHASE DATE	_____
PREVIOUS OWNER	_____
NEW OWNER	_____
NEW OWNER'S ADDRESS	_____ _____
NEW OWNER'S TELEPHONE NUMBER	_____
NEW OWNER'S EMAIL ADDRESS	_____
I have read and understood the terms and conditions of the warranty, including the servicing requirements, as applicable to this vehicle.	
Signed: _____	Date: _____



NOTES