

Cub Cadet[®]

OPERATOR'S MANUAL

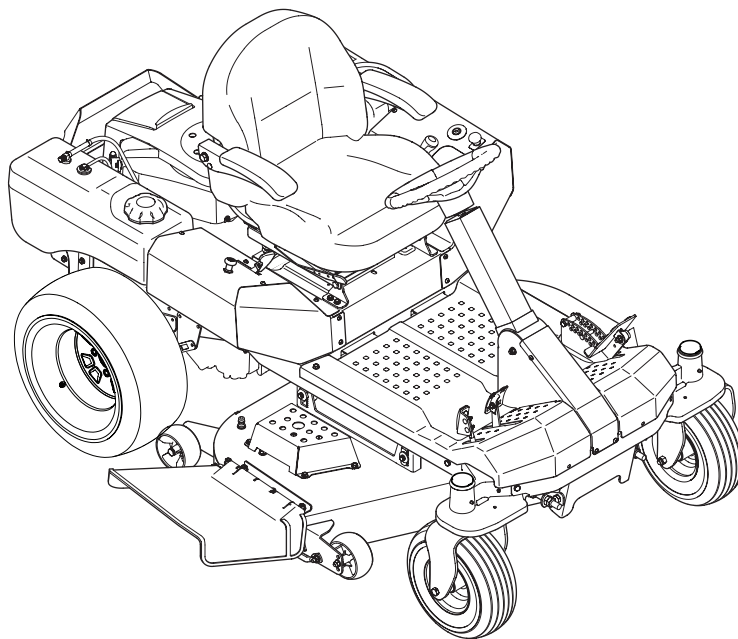

Z-Force S60 & Z-Force S48 Commercial

⚠ WARNING

**READ AND FOLLOW ALL SAFETY RULES AND INSTRUCTIONS IN THIS MANUAL
BEFORE ATTEMPTING TO OPERATE THIS MACHINE.
FAILURE TO COMPLY WITH THESE INSTRUCTIONS MAY RESULT IN PERSONAL INJURY.**

CUB CADET LLC, P.O. BOX 361131 CLEVELAND, OHIO 44136-0019

Thank You

Thank you for purchasing a Cub Cadet Zero-Turn Tractor. It was carefully engineered to provide excellent performance when properly operated and maintained.

Please read this entire manual prior to operating the equipment. It instructs you how to safely and easily set up, operate and maintain your machine. Please be sure that you, and any other persons who will operate the machine, carefully follow the recommended safety practices at all times. Failure to do so could result in personal injury or property damage.

All information in this manual is relative to the most recent product information available at the time of printing. Review this manual frequently to familiarize yourself with the machine, its features and operation. Please be aware that this Operator's Manual may cover a range of product specifications for various models. Characteristics and features discussed and/or illustrated in this manual may not be applicable to all models. We reserve the right to change product specifications, designs and equipment without notice and without incurring obligation.

If applicable, the power testing information used to establish the power rating of the engine equipped on this machine can be found at www.opei.org or the engine manufacturer's web site.

If you have any problems or questions concerning the machine, phone your local Cub Cadet dealer or contact us directly. Cub Cadet's Customer Support telephone numbers, website address and mailing address can be found on this page. We want to ensure your complete satisfaction at all times.

Throughout this manual, all references to *right* and *left* side of the machine are observed from the operating position.

Table of Contents

| | | | |
|---|-----------|--|-----------|
| Safe Operation Practices | 3 | Service | 25 |
| Assembly & Set-Up | 9 | Troubleshooting | 30 |
| Controls & Features | 12 | Replacement Parts | 31 |
| Operation | 15 | Attachments & Accessories | 33 |
| Maintenance & Adjustment | 19 | Warranties | 34 |

Record Product Information

Before setting up and operating your new equipment, please locate the model plate on the equipment and record the information in the provided area to the right. You can locate the model plate by standing at the left side of the tractor, pivoting the seat forward and looking down at the seat frame. This information will be necessary, should you seek technical support via our web site or with your local Cub Cadet dealer.

MODEL NUMBER

| | | | | | | | | | | |
|--|--|--|--|--|--|--|--|--|--|--|
| | | | | | | | | | | |
|--|--|--|--|--|--|--|--|--|--|--|

SERIAL NUMBER

| | | | | | | | | | | |
|--|--|--|--|--|--|--|--|--|--|--|
| | | | | | | | | | | |
|--|--|--|--|--|--|--|--|--|--|--|

Product Registration and Customer Support

Please register your product on our website, www.cubcadet.com.

If you have difficulty assembling this product or have any questions regarding the controls, operation, or maintenance of this machine, you can seek help from the experts. Choose from the options below:

- ◇ Visit us on the web at www.cubcadet.com



See How-to Maintenance and Parts Installation Videos at www.cubcadet.com/tutorials

- ◇ Locate your nearest Cub Cadet Dealer at (877) 282-8684
- ◇ Write to Cub Cadet LLC • P.O. Box 361131 • Cleveland, OH • 44136-0019



WARNING! This symbol points out important safety instructions which, if not followed, could endanger the personal safety and/or property of yourself and others. Read and follow all instructions in this manual before attempting to operate this machine. Failure to comply with these instructions may result in personal injury.

When you see this symbol. **HEED ITS WARNING!**

CALIFORNIA PROPOSITION 65



WARNING! Engine Exhaust, some of its constituents, and certain vehicle components contain or emit chemicals known to State of California to cause cancer and birth defects or other reproductive harm.



WARNING! Battery posts, terminals, and related accessories contain lead and lead compounds, chemicals known to the State of California to cause cancer and reproductive harm. *Wash hands after handling*



DANGER! This machine was built to be operated according to the safe operation practices in this manual. As with any type of power equipment, carelessness or error on the part of the operator can result in serious injury. This machine is capable of amputating hands and feet and throwing objects. Failure to observe the following safety instructions could result in serious injury or death.

General Operation

1. Read, understand, and follow all instructions on the machine and in the manual(s) before attempting to assemble and operate. Keep this manual in a safe place for future and regular reference and for ordering replacement parts.
2. Be familiar with all controls and their proper operation. Know how to stop the machine and disengage them quickly.
3. Never allow children under 14 years of age to operate this machine. Children 14 and over should read and understand the instructions and safe operation practices in this manual and on the machine and should be trained and supervised by an adult.
4. Never allow adults to operate this machine without proper instruction.
5. To help avoid blade contact or a thrown object injury, keep bystanders, helpers, children and pets at least 75 feet from the machine while it is in operation. Stop machine if anyone enters the area.
6. Thoroughly inspect the area where the equipment is to be used. Remove all stones, sticks, wire, bones, toys, and other foreign objects which could be picked up and thrown by the blade(s). Thrown objects can cause serious personal injury.
7. Plan your mowing pattern to avoid discharge of material toward roads, sidewalks, bystanders and the like. Also, avoid discharging material against a wall or obstruction which may cause discharged material to ricochet back toward the operator.
8. Always wear safety glasses or safety goggles during operation and while performing an adjustment or repair to protect your eyes. Thrown objects which ricochet can cause serious injury to the eyes.
9. Wear sturdy, rough-soled work shoes and close-fitting slacks and shirts. Loose fitting clothes and jewelry can be caught in movable parts. Never operate this machine in bare feet or sandals.
10. Be aware of the mower and attachment discharge direction and do not point it at anyone. Do not operate the mower without the discharge cover or entire grass catcher in its proper place.
11. Do not put hands or feet near rotating parts or under the cutting deck. Contact with the blade(s) can amputate hands and feet.

12. A missing or damaged discharge cover can cause blade contact or thrown object injuries.
13. Stop the blade(s) when crossing gravel drives, walks, or roads and while not cutting grass.
14. Watch for traffic when operating near or crossing roadways. This machine is not intended for use on any public roadway.
15. Do not operate the machine while under the influence of alcohol or drugs.
16. Mow only in daylight or good artificial light.
17. Never carry passengers.
18. Back up slowly. Always look down and behind before and while backing to avoid a back-over accident. Be aware and pay attention to the safety system function that stops power to the blades when driving in reverse. If not functioning properly, contact an authorized dealer for safety system inspection and repair.
19. Slow down before turning. Operate the machine smoothly. Avoid erratic operation and excessive speed.
20. Disengage blade(s), set parking brake, stop engine and wait until the blade(s) come to a complete stop before removing grass catcher, emptying grass, unclogging chute, removing any grass or debris, or making any adjustments.
21. Never leave a running machine unattended. Always turn off blade(s), place drive control levers in neutral, set parking brake, stop engine and remove key before dismounting.
22. Use extra care when loading or unloading the machine into a trailer or truck. This machine should not be driven up or down ramp(s), because the machine could tip over, causing serious personal injury. The machine must be pushed manually on ramp(s) to load or unload properly.
23. Muffler and engine become hot and can cause a burn. Do not touch.
24. Check overhead clearances carefully before driving under low hanging tree branches, wires, door openings etc., where the operator may be struck or pulled from the machine, which could result in serious injury.
25. Disengage all attachment clutches, set the parking brake to the 'ON' position and move the RH and LH drive control levers fully outward to the neutral position before attempting to start the engine.
26. Your machine is designed to cut normal residential grass of a height no more than 10". Do not attempt to mow through unusually tall, dry grass (e.g., pasture) or piles of dry leaves. Dry grass or leaves may contact the engine exhaust and/or build up on the mower deck presenting a potential fire hazard.
27. Use only accessories and attachments approved for this machine by the machine manufacturer. Read, understand and follow all instructions provided with the approved accessory or attachment.
28. Data indicates that operators, age 60 years and above, are involved in a large percentage of riding mower-related injuries. These operators should evaluate their ability to operate the riding mower safely enough to protect themselves and others from serious injury.
29. If situations occur which are not covered in this manual, use care and good judgment. Contact your customer service representative for assistance.

Slope Operation

Slopes are a major factor related to loss of control and tip-over accidents which can result in severe injury or death. All slopes require extra caution. If you cannot back up the slope or if you feel uneasy on it, do not mow it.

For your safety, use the slope gauge included as part of this manual to measure slopes before operating this machine on a sloped or hilly area. If the slope is greater than 15 degrees as shown on the slope gauge, do not operate this machine on that area or serious injury could result.

Do:

1. Mow across slopes, not up and down. Exercise extreme caution when changing direction on slopes.
2. Watch for holes, ruts, bumps, rocks, or other hidden objects. Uneven terrain could overturn the machine. Tall grass can hide obstacles.
3. Use slow speed. Choose a low enough speed so that you will not have to stop while on the slope. Avoid starting or stopping on a slope. If the tires are unable to maintain traction, disengage the blades and proceed slowly and carefully straight down the slope.
4. Follow the manufacturer's recommendations for wheel weights or counterweights to improve stability.
5. Use extra care with grass catchers or other attachments. These can change the stability of the machine.
6. Keep all movement on the slopes slow and gradual. Do not make sudden changes in speed or direction. Rapid acceleration or deceleration could cause the front of the machine to lift and rapidly flip over backwards, which could cause serious injury.

Do Not:

1. Do not turn on slopes unless necessary; then turn slowly uphill and use extra care while turning.
2. Do not mow near drop-offs, ditches or embankments. The mower could suddenly turn over if a wheel is over the edge of a cliff, ditch, or if an edge caves in.
3. Do not try to stabilize the machine by putting your foot on the ground.
4. Do not use a grass catcher on steep slopes.
5. Do not mow on wet grass. Reduced traction could cause sliding.
6. Do not tow heavy pull behind attachments (e.g. loaded dump cart, lawn roller, etc.) on slopes greater than 5 degrees. When going down hill, the extra weight tends to push the tractor and may cause you to lose control (e.g. tractor may speed up, braking and steering ability are reduced, attachment may jack-knife and cause tractor to overturn).

Children

1. Tragic accidents can occur if the operator is not alert to the presence of children. Children are often attracted to the machine and the mowing activity. They do not understand the dangers. Never assume that children will remain where you last saw them.
 - a. Keep children out of the mowing area and in watchful care of a responsible adult other than the operator.
 - b. Be alert and turn machine off if a child enters the area.
 - c. To avoid back-over accidents, always look behind and down for small children.
 - d. Never carry children, even with the blade(s) shut off. They may fall off and be seriously injured or interfere with safe machine operation.
 - e. Use extreme care when approaching blind corners, doorways, shrubs, trees or other objects that may block your vision of a child who may run into the path of the machine.
 - f. Keep children away from hot or running engines. They can suffer burns from a hot muffler.
 - g. Remove key when machine is unattended to prevent unauthorized operation.
2. Never allow children under 14 years of age to operate this machine. Children 14 and over should read and understand the instructions and safe operation practices in this manual and on the machine and should be trained and supervised by an adult.

Towing

1. Tow only with a machine that has a hitch designed for towing. Do not attach towed equipment except at the hitch point.
2. Follow the manufacturer's recommendation for weight limits for towed equipment and towing on slopes.
3. Never allow children or others in or on towed equipment.
4. On slopes, the weight of the towed equipment may cause loss of traction and loss of control.
5. Travel slowly and allow extra distance to stop.
6. Do not shift to neutral and coast downhill.

Suspension Seat

This unit is equipped with a heavy-duty vinyl fabric-covered seat incorporating adjustable armrests, an adjustable seat back, an adjustable fore/aft track, a weight/ride adjustable mechanical suspension system, and an Operator Presence Sensor (OPS).

- The OPS, in the form of a switch, is integrated into the seat bottom and is connected to the machine electrical system.
- The weight/ride adjustment lever is located on the right side of the seat back and incorporates three settings: light = 110 lbs, medium = 195 lbs, and heavy = 286 lbs. Lever up is light and down is heavy. Weight adjustment should be made without the operator sitting in the seat.
- The seat back recline adjustment is also on the right side between the seat back and seat bottom, and it provides up to 10 degrees.

- The fore/aft single-locking adjustment tracks operate on roller-bearings for smooth and almost effortless operation. The lever for seat track actuation is near the right front corner of the seat bottom, and allows fore/aft adjustment of 4".
- The seat is attached to pivotal brackets, which allow the seat assembly to pivot forward onto the foot platform area.
NOTE: The Operator Presence Sensor must be connected to the electrical wiring harness.

Service

Safe Handling of Gasoline:

1. To avoid personal injury or property damage use extreme care in handling gasoline. **Gasoline is extremely flammable and the vapors are explosive.** Serious personal injury can occur when gasoline is spilled on yourself or your clothes which can ignite. Wash your skin and change clothes immediately.
 - a. Use only an approved gasoline container.
 - b. Extinguish all cigarettes, cigars, pipes and other sources of ignition.
 - c. Never fuel machine indoors.
 - d. Never remove gas cap or add fuel while the engine is hot or running. Allow engine to cool at least two minutes before refueling.
 - e. Never over fill fuel tank. Fill tank to no more than ½ inch below bottom of filler neck to allow space for fuel expansion.
 - f. Replace gasoline cap and tighten securely.
 - g. If gasoline is spilled, wipe it off the engine and equipment. Move machine to another area. Wait 5 minutes before starting the engine.
 - h. To reduce fire hazards, keep machine free of grass, leaves, or other debris build-up. Clean up oil or fuel spillage and remove any fuel soaked debris.
 - i. Never store or re-fuel the machine or fuel container inside where there is an open flame, spark or pilot light as on a water heater, space heater, furnace, clothes dryer or other gas appliances.
 - j. Allow a machine to cool at least five minutes before storing.
2. Avoid Static Discharge
 - a. Never fill containers inside a vehicle or on a truck or trailer bed with a plastic liner. Always place containers on the ground away from your vehicle before filling.
 - b. When practical, remove gas-powered equipment from the truck or trailer and refuel it on the ground. If this is not possible, then refuel such equipment on a trailer with a portable container, rather than from a gasoline dispenser nozzle.
 - c. Keep the nozzle in contact with the rim of the fuel tank or container opening at all times until fueling is complete. Do not use a nozzle lock-open device.

General Service

1. Never run an engine indoors or in a poorly ventilated area. Engine exhaust contains carbon monoxide, an odorless, and deadly gas.
2. Before cleaning, repairing, or inspecting, make certain the blade(s) and all moving parts have stopped. Disconnect the spark plug wire and ground against the engine to prevent unintended starting.
3. Periodically check to make sure the blades come to complete stop within approximately (5) five seconds after operating the blade disengagement control. If the blades do not stop within the this time frame, your machine should be serviced professionally by an authorized dealer.
4. Regularly check the safety interlock system for proper function, as described later in this manual. If the safety interlock system does not function properly, have your machine serviced professionally by an authorized dealer.
5. Check the blade(s) and engine mounting bolts at frequent intervals for proper tightness. Also, visually inspect blade(s) for damage (e.g., excessive wear, bent, cracked). Replace the blade(s) with the original equipment manufacturer's (O.E.M.) blade(s) only, listed in this manual. "Use of parts which do not meet the original equipment specifications may lead to improper performance and compromise safety!"
6. Mower blades are sharp. Wrap the blade or wear gloves, and use extra caution when servicing them.
7. Keep all nuts, bolts, and screws tight to be sure the equipment is in safe working condition.
8. Never tamper with the safety interlock system or other safety devices. Check their proper operation regularly.
9. After striking a foreign object, stop the engine, disconnect the spark plug wire(s) and ground against the engine. Thoroughly inspect the machine for any damage. Repair the damage before starting and operating.
10. Never attempt to make adjustments or repairs to the machine while the engine is running.
11. Grass catcher components and the discharge cover are subject to wear and damage which could expose moving parts or allow objects to be thrown. For safety protection, frequently check components and replace immediately with original equipment manufacturer's (O.E.M.) parts only, listed in this manual. "Use of parts which do not meet the original equipment specifications may lead to improper performance and compromise safety!"
12. Do not change the engine governor settings or over-speed the engine. The governor controls the maximum safe operating speed of the engine.
13. Maintain or replace safety and instruction labels, as necessary.
14. Observe proper disposal laws and regulations for gas, oil, etc. to protect the environment.
15. According to the Consumer Products Safety Commission (CPSC) and the U.S. Environmental Protection Agency (EPA), this product has an *Average Useful Life* of seven (7) years, or 270 hours of operation. At the end of the *Average Useful Life* have the machine inspected annually by an authorized service dealer to ensure that all mechanical and safety systems are working properly and not worn excessively. Failure to do so can result in accidents, injuries or death.

Do not modify engine

To avoid serious injury or death, do not modify engine in any way. Tampering with the governor setting can lead to a runaway engine and cause it to operate at unsafe speeds. Never tamper with factory setting of engine governor.

Notice Regarding Emissions

Engines which are certified to comply with California and federal EPA emission regulations for SORE (Small Off Road Equipment) are certified to operate on regular unleaded gasoline, and may include the following emission control systems: Engine Modification (EM) and Three Way Catalyst (TWC) if so equipped.

When required, models are equipped with low permeation fuel lines and fuel tanks for evaporative emission control. California models may also include a carbon canister. Please contact Customer Support for information regarding the evaporative emission control configuration for your model.

Spark Arrestor









WARNING! This machine is equipped with an internal combustion engine and should not be used on or near any unimproved forest-covered, brush-covered or grass-covered land unless the engine's exhaust system is equipped with a spark arrestor meeting applicable local or state laws (if any).

If a spark arrestor is used, it should be maintained in effective working order by the operator. In the State of California the above is required by law (Section 4442 of the California Public Resources Code). Other states may have similar laws. Federal laws apply on federal lands.

A spark arrestor for the muffler is available through your nearest engine authorized service dealer or contact the service department, P.O. Box 361131 Cleveland, Ohio 44136-0019.

Safety Symbols

This page depicts and describes safety symbols that may appear on this product. Read, understand, and follow all instructions on the machine before attempting to assemble and operate.

| Symbol | Description |
|---|--|
|  | READ THE OPERATOR'S MANUAL(S) Read, understand, and follow all instructions in the manual(s) before attempting to assemble and operate |
|  | WARNING— ROTATING BLADES Do not put hands or feet near rotating parts or under the cutting deck. Contact with the blade(s) can amputate hands and feet. |
|  | WARNING—THROWN OBJECTS This machine may pick up and throw and objects which can cause serious personal injury. |
|  | WARNING—THROWN OBJECTS This machine may pick up and throw and objects which can cause serious personal injury. |
|  | BYSTANDERS Keep bystanders, helpers, children and pets at least 75 feet from the machine while it is in operation. |
|  | WARNING— SLOPE OPERATION Do not operate this machine on a slope greater than 15 degrees. |
|  | DANGER — ROTATING BLADES To reduce the risk of injury, keep hands and feet away. Do not operate unless discharge cover or grass catcher is in its proper place. If damaged, replace immediately. |



WARNING! Your Responsibility—Restrict the use of this power machine to persons who read, understand and follow the warnings and instructions in this manual and on the machine.

SAVE THESE INSTRUCTIONS!

Slope Gauge

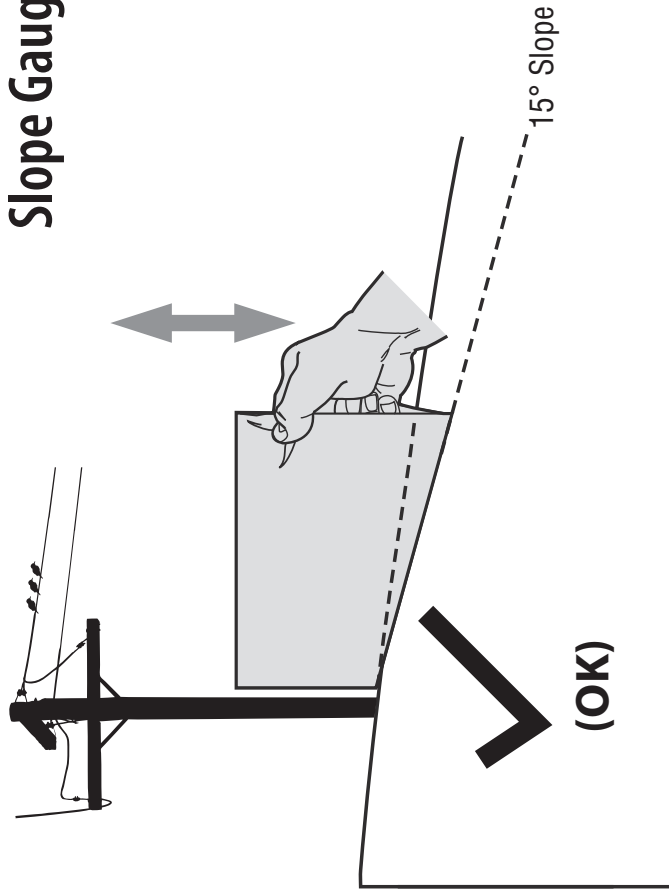

Figure 1

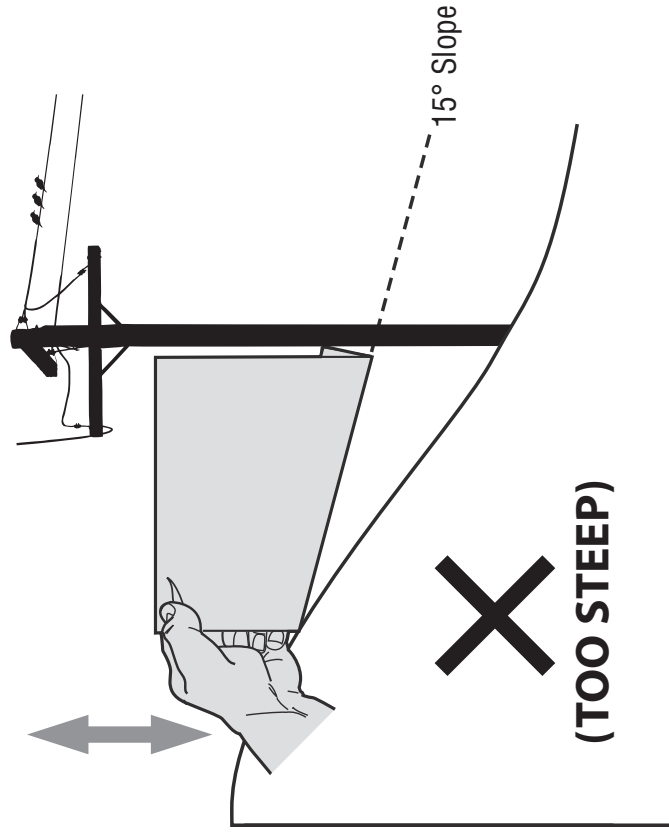

Figure 2

15° dashed line

USE THIS SLOPE GAUGE TO DETERMINE IF A SLOPE IS TOO STEEP FOR SAFE OPERATION!

To check the slope, proceed as follows:

1. Remove this page and fold along the dashed line.
2. Locate a vertical object on or behind the slope (e.g. a pole, building, fence, tree, etc.)
3. Align either side of the slope gauge with the object (See Figure 1 and Figure 2).
4. Adjust gauge up or down until the left corner touches the slope (See Figure 1 and Figure 2).
5. If there is a gap below the gauge, the slope is too steep for safe operation (See Figure 2 above).



WARNING! Slopes are a major factor related to tip-over and roll-over accidents which can result in severe injury or death. Do not operate machine on slopes in excess of 15 degrees. All slopes require extra caution.

Always mow across the face of slopes, never up and down slopes.

Contents of Crate

- One Lawn Tractor
- One Oil Drain Hose
- One Deck Wash Hose Coupler
- One Z-Force S Operator's Manual
- One Engine Operator's Manual

Tractor Preparation

1. Remove the upper crating material from the shipping pallet, and cut any bands or tie straps securing the tractor to the pallet.
2. If the deck is not in the highest mowing position (pushed all the way forward), use the deck lift pedal to raise the deck to its highest position. Refer to the Controls & Features section for instructions on raising and lowering the deck.
3. Disengage the parking brake.
4. Engage the transmission bypass rods on each side of the tractor; then carefully roll the tractor off the shipping pallet. The transmission bypass rods (one for each the RH and LH transmission) are located on the rear of the tractor, just inside each rear wheel. Disengage the bypass rods. See Figure 3-1.

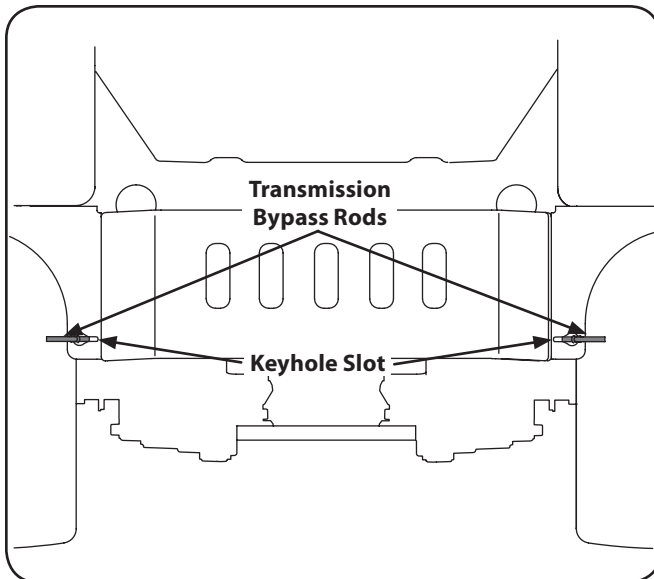

Figure 3-1

5. Remove the deck wash system nozzle adapter and oil drain tube from the manual bag and store for future use.

Steering Wheel Column

The steering wheel column is tilted all the way back for shipping purposes. To tilt the column forward, press the steering tilt pedal. Release the steering tilt pedal when the column is in the desired position.

Steering Wheel

1. Remove the hardware for attaching the steering wheel from beneath the steering wheel cap. Carefully pry off the steering wheel cover to remove the hardware.
2. With the wheels of the tractor pointing straight forward, place the steering wheel over the steering shaft.
3. Place the flat washer and belleville washer over the steering wheel and secure with the hex screw. See Figure 3-2.

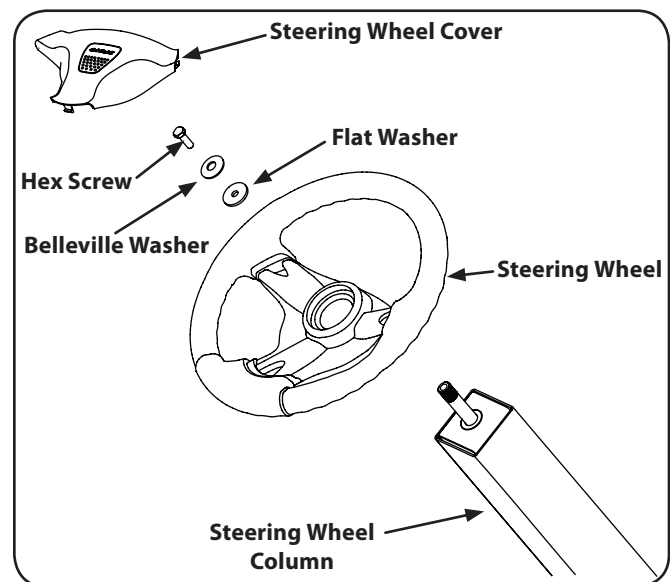

Figure 3-2

4. Place the steering wheel cover over the center of the steering wheel and push downward until it "clicks" into place.

Install Operator's Seat

To install the seat proceed as follows:

NOTE: The seat is shipped with the seat switch and seat pan attached. A second person may be needed to hold the seat.

1. Cut any straps securing the seat assembly to the tractor. Remove any packing material.

NOTE: Be careful not to cut the wiring harness connecting the seat and the seat switch in the bottom of the seat.

- Remove the two shoulder bolts and lock nuts in the seat pan as shown in Figure 3-3.

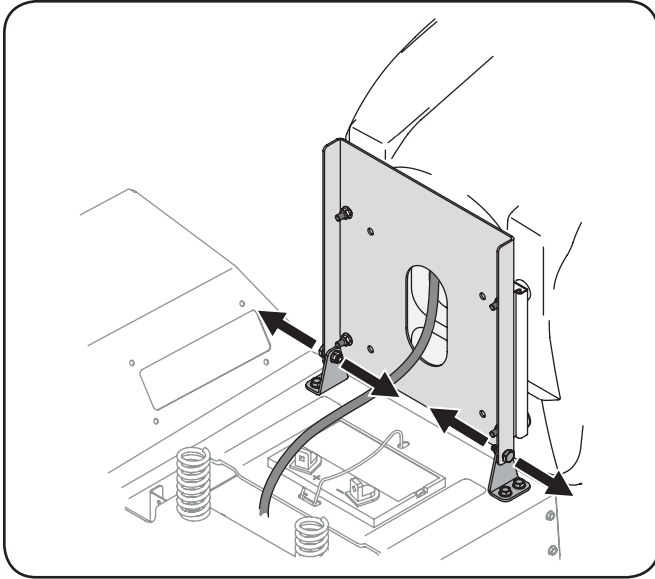

Figure 3-3

- Rotate the seat into position and secure the seat into place with the previously removed shoulder bolts and lock nuts. Be careful not to crimp or damage the wire harness while installing the seat. See Figure 3-4.

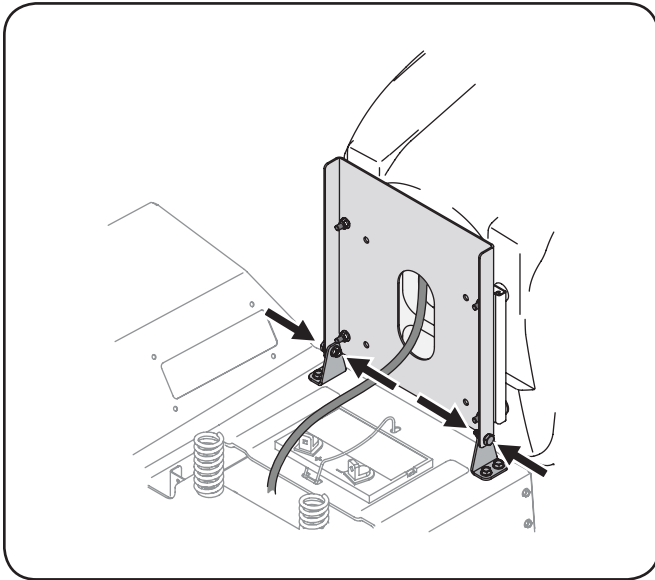

Figure 3-4

Adjusting the Seat

To adjust the position of the seat, push the seat adjustment lever to the left. Slide the seat forward or rearward to the desired position; then release the adjustment lever. Make sure seat is locked into position before operating the tractor. See Figure 3-5.

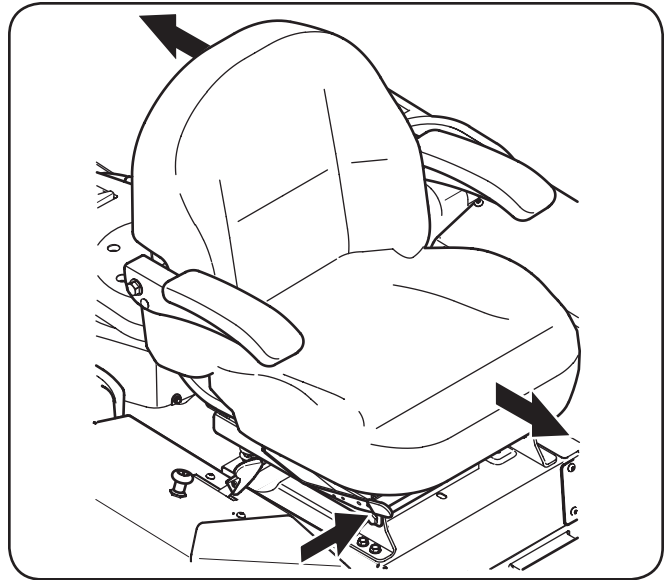

Figure 3-5

Install the Rear Hitch Bracket

- Remove the hex flange screws and flange lock nuts that secure the hitch bracket and muffler mount bracket to the bumper bracket. See Figure 3-6.

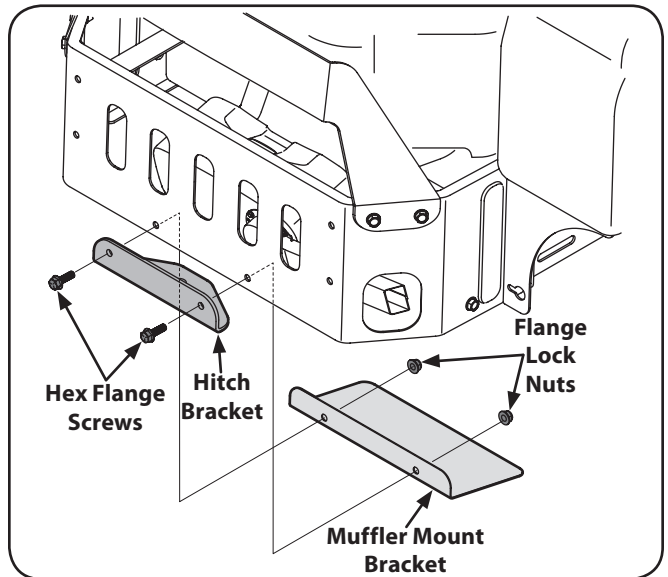

Figure 3-6

2. Install the hitch bracket and muffler mount bracket as shown in Figure 3-7 and secure with the hex flange screws and flange lock nuts removed in step 1.

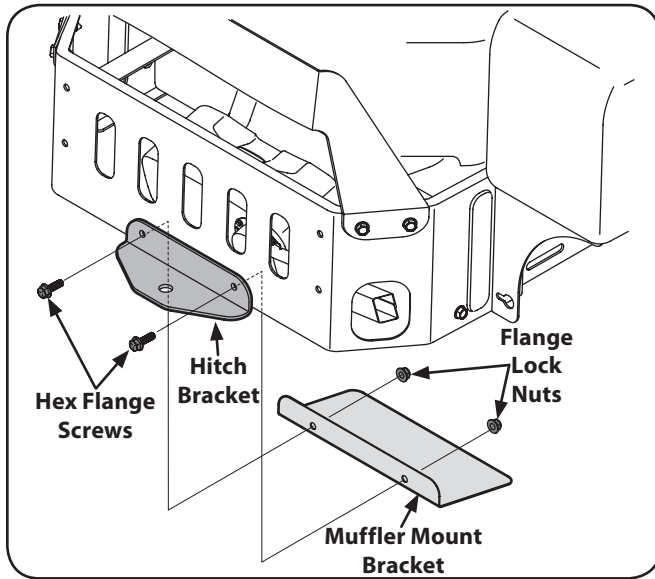

Figure 3-7

Fuel Fill-Up

Using a good grade of unleaded regular gasoline, fill the tank (beside the engine on the both sides of the mower). When the fuel tank reaches one inch from the top of the tank, stop, **DO NOT OVERFILL**. Space must be left for expansion.

Connecting the Battery Cables



CALIFORNIA PROPOSITION 65 WARNING!

Battery posts, terminals, and related accessories contain lead and lead compounds, chemicals known to the State of California to cause cancer and reproductive harm. Wash hands after handling.



CAUTION: When attaching battery cables, always connect the POSITIVE (Red) wire to its terminal first, followed by the NEGATIVE (Black) wire.

For shipping reasons, both battery cables on your equipment may have been left disconnected from the terminals at the factory. To connect the battery cables, proceed as follows:

NOTE: The positive battery terminal is marked Pos. (+). The negative battery terminal is marked Neg. (-).

NOTE: If the positive battery cable is already attached, skip ahead to step 2.

1. Remove the plastic cover, if present, from the positive battery terminal and attach the red cable to the positive battery terminal (+) with the bolt and hex nut. See Figure 3-8.

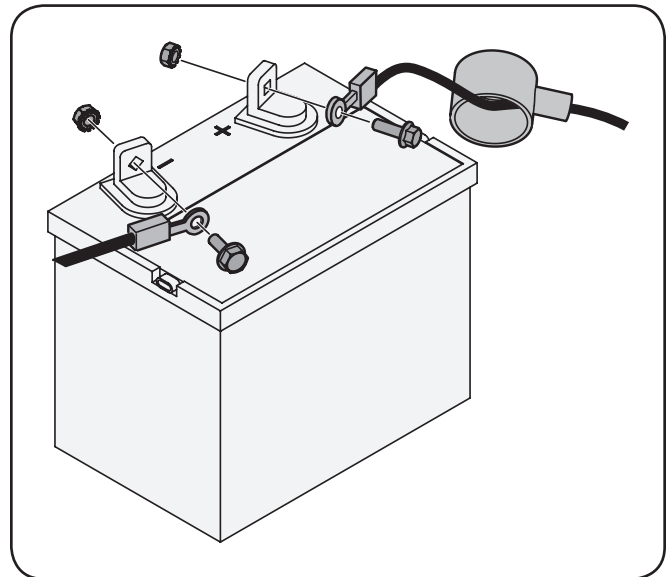
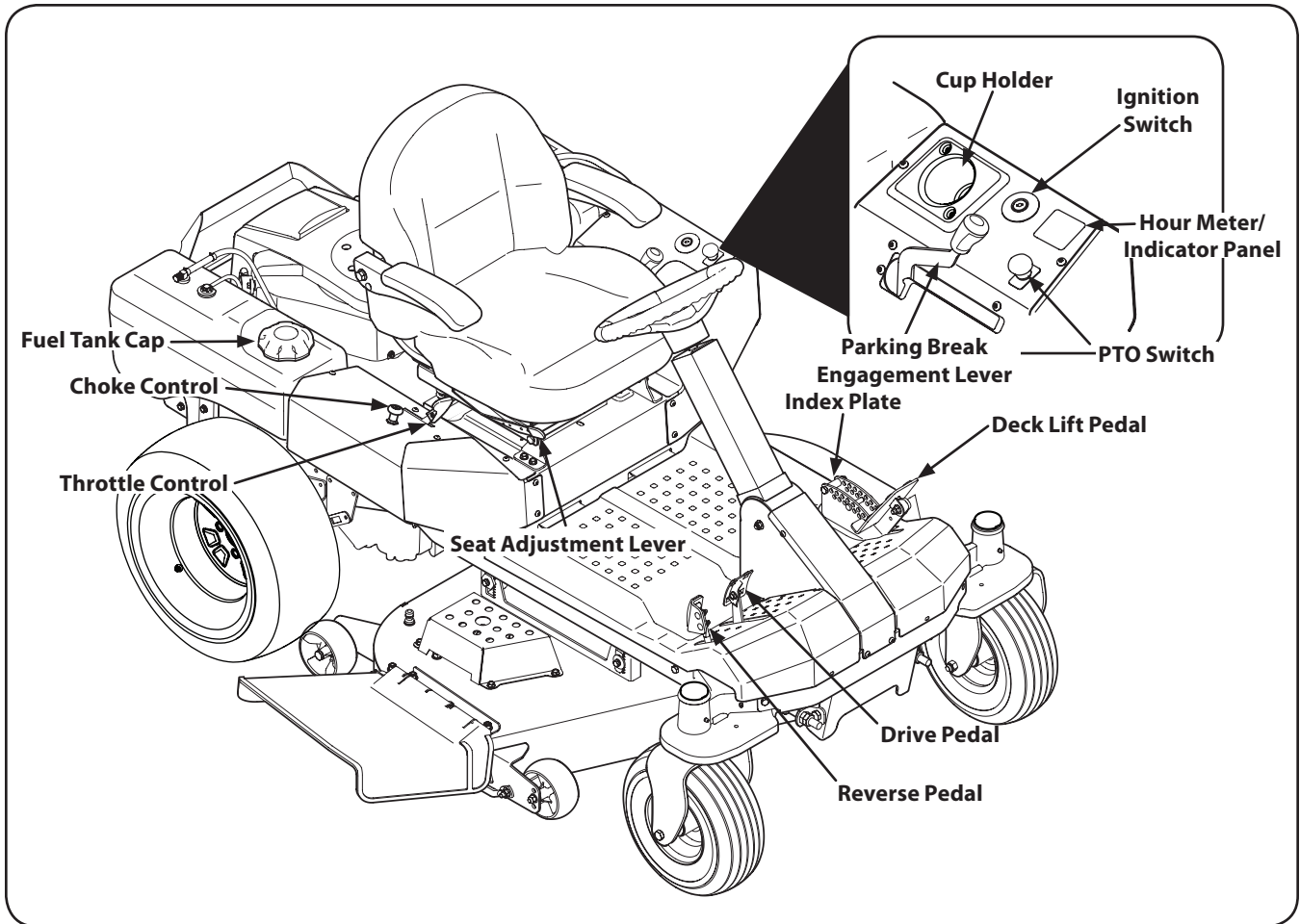

Figure 3-8

2. Remove the plastic cover, if present, from the negative battery terminal and attach the black cable to the negative battery terminal (-) with the bolt and hex nut. See Figure 3-8.
3. Position the red rubber boot over the positive battery terminal to help protect it from corrosion.

NOTE: If the battery is put into service after the date shown on top/side of battery, charge the battery as instructed in the Maintenance section your Operator's Manual prior to operating the tractor.



NOTE: References to LEFT, RIGHT, FRONT, and REAR indicate that position on the tractor when facing forward while seated in the operator's seat.

Deck Lift Pedal

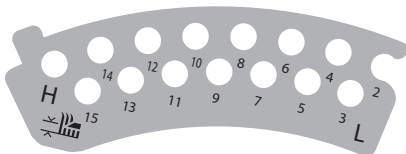

The deck lift pedal is located near the front of the tractor on the left of the foot platform and is used to raise and lower the mower deck. The deck lift pedal has 17 positions including the transport position.

Push the pedal forward and rock back to lock into the transport position, locking behind the notch on the front of the index plate. Remove and replace the lock rod into the desired height index hole, then push pedal forward and rock forward to unlock and slowly allow the pedal to move back until it reaches the lock rod.

Ignition Switch

The ignition switch is located on the LH console to the right of the operator's seat. The ignition switch has three positions as follows:

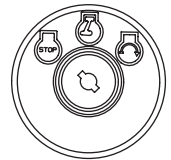

STOP — The engine and electrical system is turned off.

RUN — The tractor electrical system is energized.

START — The starter motor will turn over the engine. Release the key immediately when the engine starts

NOTE: To prevent accidental starting and/or battery discharge, remove the key from the ignition switch when the tractor is not in use.

Fuel Tank Cap

The fuel tank cap is located on the right console. Turn the fill cap to remove. Always re-install the fuel cap tightly onto the fuel tank after removing.



WARNING! Never fill the fuel tank when the engine is running. If the engine is hot from recently running, allow to cool for several minutes before refueling. Highly flammable gasoline could splash onto the engine and cause a fire.

PTO (Power Take-Off) Switch

The PTO switch is located on the LH console to the left of the operator's seat.

The PTO switch operates the electric PTO clutch mounted on the bottom of the engine crankshaft. Pull the switch knob upward to engage the PTO clutch, or push the knob downward to disengage the clutch.

The PTO switch must be in the "disengaged" position when starting the engine.

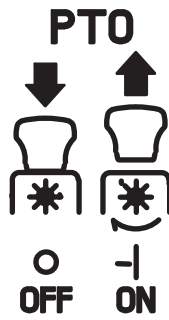

Transmission Bypass Rods (Not Visible)

The transmission bypass rods (one for each the RH and LH transmission) are located on the rear of the tractor, just inside each rear wheel, below the fuel tank and the storage tray.

When engaged, the two rods open a bypass within the hydrostatic transmissions, which allows the tractor to be pushed short distances by hand.



CAUTION: Never tow your tractor. Towing the tractor with the rear wheels on the ground may cause severe damage to the transmissions.

Hour Meter/Indicator Panel

The hour meter/indicator panel is located on the LH console to the left of the operator's seat.

Hour Meter Features

The hour meter records the hours that the tractor has been operated in the digital display (tenths of an hour - right most digit).

NOTE: The hour meter is activated whenever the ignition switch is turned to the "ON" position. Keep a record of the actual hours of operation to assure all maintenance procedures are completed according to the instructions in this manual and the engine manual.

When key is turned to the "ON" position, the battery indicator light briefly illuminates and the battery voltage is briefly displayed. The display then changes to the accumulated hours.

The Indicator Monitor will also remind the operator of maintenance intervals for changing the engine oil. The LCD will alternately flash, "CHG"; "OIL" and the recorded hours for five minutes after every 50 hours of recorded operation. The maintenance interval lasts for two hours (from 50-52, 100-102, 150-152, etc.). The LCD will flash as described for five minutes every time the tractor's engine is started during this maintenance interval. Follow the oil change intervals provided in the engine manual.

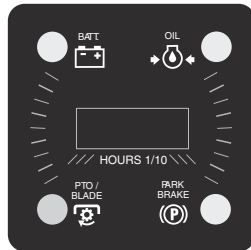

Indicator Panel Features

Battery Indicator

Illuminates and the battery voltage is displayed briefly when the ignition switch is turned to the "ON" position.

Illuminates to indicate the battery voltage has dropped below 11.5 (+0.5/-1.0) volts. The battery voltage is also displayed on the hour meter. If this indicator and display come on during operation, check the battery and charging system for possible causes and/or contact your Cub Cadet dealer.

Oil Pressure Indicator (If Engine So Equipped)

This warning lamp indicates low engine oil pressure. If the indicator comes on while the engine is running, stop the engine immediately and check for possible causes. Do not run the engine while this indicator is illuminated. Contact your Cub Cadet dealer to have the tractor and engine inspected.

NOTE: The oil pressure indicator may illuminate when the ignition switch is in the ON position, but should turn off when the engine is started.

PTO Engaged Indicator

This indicator illuminates when the PTO switch is pulled upward in the "ENGAGED" position and the ignition switch is turned to the "START" position. Check this indicator if the engine will not crank with the ignition switch in the "START" position. If necessary, move the PTO switch to the "DISENGAGED" position.

Parking Brake Engaged Indicator

This indicator illuminates when the parking brake is in the DISENGAGED position and the ignition switch is turned to the "START" position. Check this indicator if the engine will not crank with the ignition switch in the "START" position. If necessary, move the parking brake to the ENGAGED position.

This indicator also illuminates when the ignition switch is turned to the "START" position and the RH and/or LH drive control levers are in a position other than the fully out in neutral position. Move the control levers fully outward.

Throttle Control

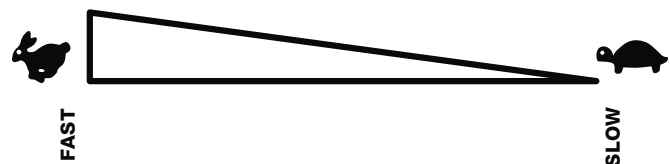

The throttle control is located on the RH console to the right of the operator's seat. When set in a given position, a uniform engine speed will be maintained.

Push the throttle control handle forward to increase the engine speed. The tractor is designed to operate with the throttle control in the fast position  (full throttle) when the tractor is being driven and the mower deck is engaged.

Pull the throttle control handle rearward to decrease the engine speed.

Choke Control

The choke knob controls the position of the engine choke and is located on the RH console. Pull the knob out to choke the engine; push the knob in to open the choke.



Parking Brake Engagement Lever



The parking brake engagement lever is located on the left of the seat box frame, and is used to engage the parking brake.

Pull the lever reward to stop the tractor or slow it down.

Pull the lever fully rearward and to the right; then into the short "J" slot to engage the brake.

Pull the lever up out of the "J" slot and to the left; then completely forward to disengage the parking brake.

Drive Pedal

The drive pedal is located on the right side of the tractor, along the running board. Press the drive pedal forward to cause the tractor to travel forward. Ground speed is also controlled with the drive pedal. The further forward the pedal is pivoted, the faster the tractor will travel. The pedal will return to its original position when it's not pressed.



Reverse Pedal

The reverse pedal is located on the right side of the tractor along the running board. Ground speed is also controlled with the reverse pedal. The further downward the pedal is pivoted, the faster the tractor will travel. The pedal will return to its original position when it's not pressed.



Cup Holders

The cup holders are located on the LH console to the left of the operator's seat and on the LH utility bin.

Storage Tray

The storage tray is located at the rear of the LH console.

Seat Adjustment Lever

The seat adjustment lever is located below the front/left of the seat. The lever allows for adjustment of the fore to aft position of the operator's seat. Refer to the Assembly & Set-Up section for instructions on adjusting the seat position.

Steering Column Adjustment (Not Visible)

The angle of the steering column can be adjusted up or down. To adjust the steering wheel column press the pedal at the base of the column down and move the column into the desired position and release the pedal to lock into place.

Transmission Oil Expansion Reservoir (Not Shown)

The transmission oil expansion reservoir is connected by hoses to the RH and LH transmission assemblies, and is located behind the seat box. The function of the reservoir is to hold the natural expansion of transmission oil that occurs as the transmission warms up during operation. **DO NOT FILL THE RESERVOIR.**

Under normal operating conditions, no oil should be added to the reservoir. The COLD oil level should be no higher than approximately $\frac{1}{4}$ " (the "Full Cold" mark) above the bottom of the reservoir. See Figure 4-1.

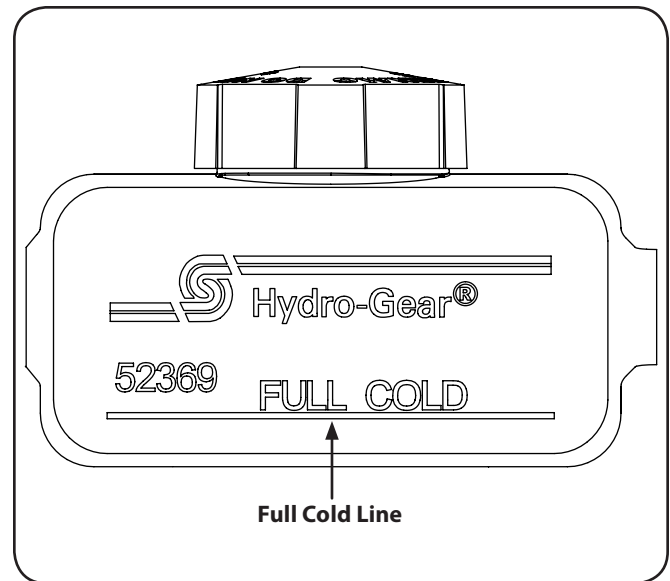

Figure 4-1

NOTE: Prior to the initial operation of the tractor, the oil level in the reservoir may be slightly higher than the maximum due to air in the oil lines. Operation of the tractor will eventually purge the air from the lines and the oil level will settle to the maximum.

General Safety

- **RECEIVE INSTRUCTION** — Entirely read this operator's manual. Learn to operate this machine SAFELY. Do not risk INJURY or DEATH. Allow only those who have become competent in its usage to operate this tractor.
- Before starting the engine or beginning operation, be familiar with the controls. The operator should be in the operator's seat. The PTO switch must be in the disengaged position and the parking brake engaged.
- Keep all shields in place. Keep away from moving parts.
- **NO RIDERS!** Keep all people and pets a safe distance away. Look behind and down to both sides of the tractor before and while backing up.
- **DO NOT** direct the mower discharge at people.
- Avoid slopes where possible. Never operate on slopes greater than 15°. Slopes with a greater incline present dangerous operating conditions. Tractors can be rolled over.
- Before leaving the operator's seat: Shut off the PTO and engage the parking brake, shut off the engine and remove the ignition key. Wait for all movement to stop before servicing or cleaning.
- Avoid any sudden movements of the steering wheel when starting and stopping. Keep a firm grip on the steering wheel.
- Be careful when operating near roadways. Stop the tractor motion and wait for vehicles to pass before operating along the road.
- Do not operate the tractor with the mower deck removed. Removal of the deck will change the balance of the tractor, and could contribute to a tractor rollover.
- Avoid operation on traction surfaces that are unstable; use extreme caution if the surface is slippery.
- Slow down before turning and come to a complete stop before any zero turn maneuver.
- Do not stop the tractor or park the tractor over combustible materials such as dry grass, leaves, debris, etc.
- Do not fill the fuel tank when the engine is running or while the engine is hot. Allow the engine several minutes to cool before refueling. Tighten the fuel cap securely.

Before Operating Your Tractor

- Before you operate the tractor, study this manual carefully to familiarize yourself with the operation of all the instruments and controls. It has been prepared to help you operate and maintain your tractor efficiently.
- This engine is certified to operate only on clean, fresh, unleaded regular gasoline. For best results, fill the fuel tank with only clean, fresh, unleaded gasoline with a pump sticker octane rating of 87 or higher.
- Unleaded gasoline is recommended because it leaves less combustion chamber deposits and reduces harmful exhaust emissions. Leaded gasoline is not recommended and must not be used where exhaust emissions are regulated.
NOTE: Purchase gasoline in small quantities. Do not use gasoline left over from the previous season, to minimize gum deposits in the fuel system.
- Gasohol (up to 10% ethyl alcohol, 90% unleaded gasoline by volume) is an approved fuel. Other gasoline/alcohol blends are not approved.
- Methyl Tertiary Butyl Ether (MTBE) and unleaded gasoline blends (up to a maximum of 15% MTBE by volume) are approved fuels. Other gasoline/ether blends are not approved.
- Check the engine oil level.
- Clean the air cleaner element if necessary.
- Check the tire inflation pressures.
- Adjust the seat for operator's maximum comfort, visibility and for maintaining complete control of the tractor.

Safety Interlock Switches

This tractor is equipped with a safety interlock system for the protection of the operator. If the interlock system should ever malfunction, do not operate the tractor. Contact your Cub Cadet dealer.

- The safety interlock system prevents the engine from cranking or starting unless the parking brake is engaged, and the PTO (Blade Engage) knob is in the disengaged (OFF) position.
- The engine will automatically shut off if the operator leaves the seat before engaging the parking brake.



WARNING! Do not operate the tractor if the interlock system is malfunctioning. This system was designed for your safety and protection.

Engaging the PTO

Engaging the PTO transfers power to the cutting deck or other (separately available) attachments. To engage the PTO:

1. Move the throttle control lever to the FAST  position.
2. Pull the PTO/Blade Engage knob outward into the engaged (ON) position. See Figure 5-1.

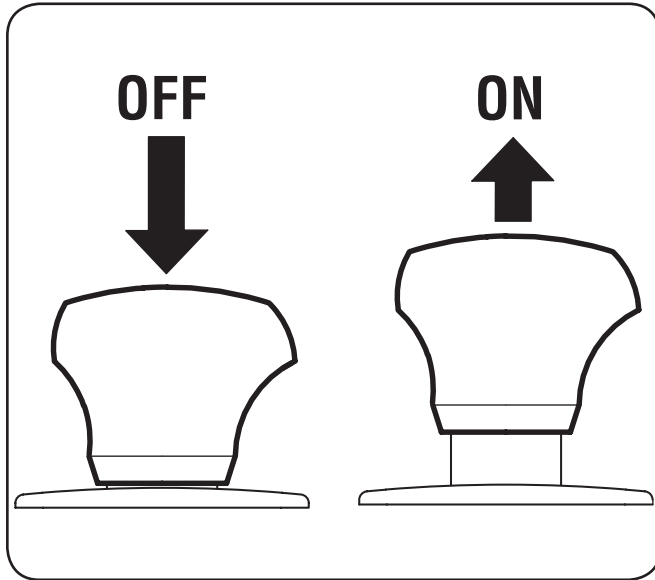



Figure 5-1

NOTE: Always operate the tractor with the throttle lever in the FAST  position for the most efficient use of the cutting deck or other (separately available) attachments.

Using the Deck Lift Pedal

Push the pedal forward until it locks into the transport position, locking behind the notch on the front of the index plate. Remove and replace the lock pin into the desired height index hole, then press down on the lift pedal and slowly allow the pedal to move back until it reaches the lock pin.

Starting the Engine



WARNING! This tractor is equipped with a safety interlock system designed for the protection of the operator. Do not operate the tractor if any part of the interlock system is malfunctioning. Periodically check the functions of the interlock system for proper operation.



WARNING! For personal safety, the operator must be sitting in the tractor seat when starting the engine.

NOTE: Refer to the Engine Operator's Manual for oil fill-up instructions and refer to the Assembly & Set-Up section for gasoline fill-up instructions.

1. Operator must be sitting in the tractor seat.
2. Engage the parking brake. Refer to Figure 5-2.

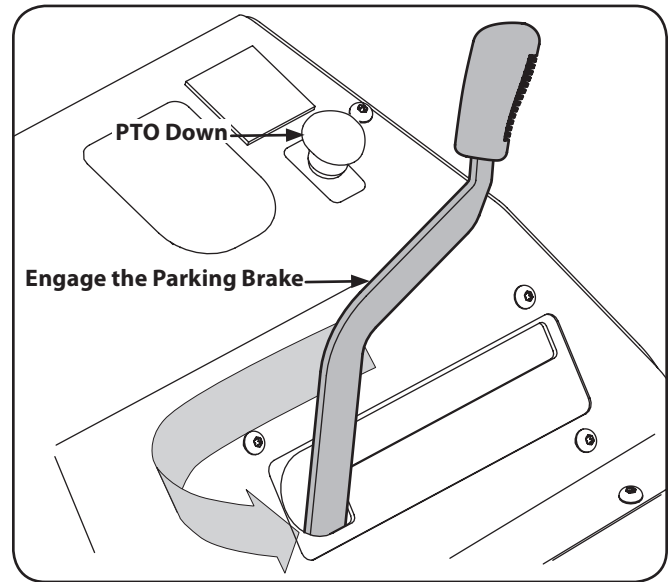



Figure 5-2

3. Make certain the PTO switch is in the disengaged (down) position. Refer to Figure 5-2.
4. Pull the choke control upward into the full choke position
NOTE: If the engine is warmed up, it may not be necessary to place the choke control in the choke position.
5. Move the throttle control to midway between its SLOW  and FAST  positions.
6. Turn the ignition key clockwise to the START position. After the engine starts, release the key. It will return to the NORMAL MOWING position.



CAUTION: Do NOT hold the key in the START position for longer than ten seconds at a time. Doing so may cause damage to your engine's electric starter.

7. After the engine starts, deactivate the choke control.

NOTE: Do NOT leave the choke control on while operating the tractor. Doing so will result in a "rich" fuel mixture and cause the engine to run poorly.

- Allow the engine to run for a few minutes at mid-throttle before putting the engine under load.
- Observe the hour meter/indicator panel. If the battery indicator light or oil pressure light come on, immediately stop the engine. Have the tractor inspected by your Cub Cadet dealer.

Cold Weather Starting

When starting the engine at temperatures near or below freezing, ensure the correct viscosity motor oil is used in the engine and the battery is fully charged. Start the engine as follows:

- Be sure the battery is in good condition. A warm battery has much more starting capacity than a cold battery.
- Use fresh winter grade fuel. Winter grade gasoline has higher volatility to improve starting. Do not use gasoline left over from summer.
- Follow the previous instruction for Starting the Engine.

Using Jumper Cables To Start Engine



WARNING! Batteries contain sulfuric acid and produce explosive gasses. Make certain the area is well ventilated, wear gloves and eye protection, and avoid sparks or flames near the battery.

If the battery charge is not sufficient to crank the engine, recharge the battery. If a battery charger is unavailable and the tractor must be started, the aid of a booster battery will be necessary. Connect the booster battery as follows:

- Connect the end of one cable to the disabled tractor battery's positive terminal; then connect the other end of that cable to the booster battery's positive terminal.
- Connect one end of the other cable to the booster battery's negative terminal; then connect the other end of that cable to the frame of the disabled tractor, as far from the battery as possible.
- Start the disabled tractor following the normal starting instructions previously provided; then disconnect the jumper cables in the exact reverse order of their connection.
- Have the tractor's electrical system checked and repaired as soon as possible to eliminate the need for jump starting.

Stopping the Engine

- Place the PTO switch in the "OFF" position.
- Engage the parking brake.
- Move the throttle control to the SLOW  position and allow the engine to idle for about one minute.
- Turn the ignition key to the "OFF" position and remove the key from the ignition switch.

NOTE: Always remove the key from the ignition switch to prevent accidental starting or battery discharge if the equipment is left unattended.

Driving The Tractor



WARNING! Avoid sudden starts, excessive speed and sudden stops.

- Release the parking brake. Move the throttle lever into the FAST  position.
- To travel FORWARD, slowly press the drive pedal forward until the desired speed is achieved. See Figure 5-3.

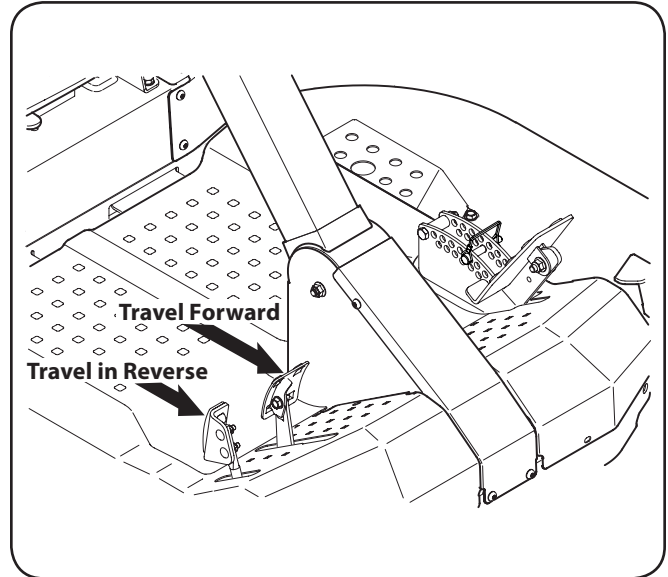

Figure 5-3

- To stop or slow down the tractor, take your foot off of the forward or reverse drive pedal. To lock the parking brake, pull the lever fully rearward and to the right; then into the short "J" slot to engage the brake. Pull the lever up out of the "J" slot and to the left; then completely forward to disengage the parking brake.
- NOTE:** The forward and reverse pedals must not be used when the brake is partially engaged. When the brake is locked in the "J" the drive belt is disengaged but if the brake is only part way back then the brakes are engaged but so is the drive belt so transmission damage will occur if you push forward or reverse.
- To travel in REVERSE, check that the area behind is clear then slowly reverse pedal with the ball of your foot (NOT your heel) until the desired speed is achieved. See Figure 5-3.



CAUTION: Do NOT attempt to change the direction of travel when the tractor is in motion. Always bring the tractor to a complete stop before moving the tractor from forward to reverse or vice versa.



WARNING! Do not leave the seat of the tractor without first placing the PTO/Blade Engage knob in the disengaged (OFF) position and engaging the parking brake. If leaving the tractor unattended, also turn the engine off and remove the ignition key.

Driving On Slopes

Refer to the SLOPE GAUGE on page 8 to help determine slopes where you may operate the tractor safely.



WARNING! Do not mow on inclines with a slope in excess of 15 degrees (a rise of approximately 2-1/2 feet every 10 feet). The tractor could overturn and cause serious injury.

- Mow across slopes, not up and down.
- Exercise extreme caution when changing direction on slopes.
- Watch for holes, ruts, bumps, rocks, or other hidden objects. Uneven terrain could overturn the machine. Tall grass can hide obstacles.
- Do not turn on slopes unless necessary; then turn slowly uphill and use extra care while turning. Turning up a slope greatly increases the chance of a rollover.
- Avoid stopping when driving up a slope. If it is necessary to stop while driving up a slope, start up smoothly and carefully to reduce the possibility of flipping the tractor over backward.

Mowing



WARNING! To help avoid blade contact or a thrown object injury, keep bystanders, helpers, children and pets at least 75 feet from the machine while it is in operation. Stop machine if anyone enters the area.

The following information will be helpful when using the cutting deck with your tractor.



WARNING! Plan your mowing pattern to avoid discharge of materials toward roads, sidewalks, bystanders and the like. Also, avoid discharging material against a wall or obstruction which may cause discharged material to ricochet back toward the operator.

- Do not mow at high ground speed, especially if a mulch kit or grass collector is installed.
- Do not cut the grass too short. Short grass is prone to weed growth and yellows quickly in dry weather.
- Always operate the tractor with the throttle lever in the FAST  position while mowing.
- For best results it is recommended that the first two laps be cut with the discharge thrown towards the center. After the first two laps, reverse the direction to throw the discharge to the outside for the balance of cutting. This will give a better appearance to the lawn.
- Do NOT attempt to mow heavy brush and weeds or extremely tall grass. Your tractor is designed to mow lawns, NOT clear brush.
- Keep the blades sharp and replace the blades when worn.

Maintenance Schedule

| | Before Each use | Every 10 Hours | Every 25 Hours | Prior to Storing |
|---|-----------------|----------------|----------------|------------------|
| Clean Battery Terminals | | ✓ | | ✓ |
| Lube Front Caster Wheels and Wheel Spindles | | | ✓ | ✓ |
| Check Engine Cooling Fins for Debris (Clean as Necessary) | ✓ | | | ✓ |
| Lube Deck Spindles | | | ✓ | ✓ |
| Lube Pedal Pivot Points | | ✓ | | ✓ |

Maintenance



WARNING! Before performing any maintenance or repairs, disengage PTO, set parking brake, stop engine and remove key to prevent unintended starting.

Engine

Refer to the Engine Operator's Manual for all engine maintenance procedures and instructions.

NOTE: Maintenance, repair, or replacement of the emission control devices and systems which are being done at owner's expense may be performed by any engine repair establishment or individual. Warranty repairs must be performed by a Cub Cadet Dealer.

Battery



CALIFORNIA PROPOSITION 65 WARNING! Battery posts, terminals, and related accessories contain lead and lead compounds, chemicals known to the State of California to cause cancer and reproductive harm. Wash hands after handling.

The battery is sealed and is maintenance-free. Acid levels cannot be checked and fluid can not be added.

- Always keep the battery cables and terminals clean and free of corrosive build-up.
- After cleaning the battery and terminals, apply a light coat of petroleum jelly or grease to both terminals.



CAUTION: If removing the battery for cleaning, disconnect the NEGATIVE (Black) wire from its terminal first, followed by the POSITIVE (Red) wire. When re-installing the battery, always connect the POSITIVE (Red) wire its terminal first, followed by the NEGATIVE (Black) wire. Be certain that the wires are connected to the correct terminals; reversing them could result in serious damage to your engine's alternating system.

Battery Storage

1. When storing the tractor for extended periods, disconnect the negative battery cable. It is not necessary to remove the battery.
2. All batteries discharge during storage. Keep the exterior of the battery clean, especially the top. A dirty battery will discharge more rapidly.
3. The battery must be stored with a full charge. A discharged battery can freeze sooner than a charged battery. A fully charged battery will store longer in cold temperatures than hot.
4. Recharge the battery before returning to service. Although the tractor may start, the engine charging system may not fully recharge the battery.

Tractor Storage

If your tractor is not going to be operated for an extended period of time (thirty days to approximately six months), the tractor should be prepared for storage. Store the tractor in a dry and protected location. If stored outside, cover the tractor (including the tires) to protect it from the elements. The procedures outlined below should be performed whenever the tractor is placed in storage.

1. Change the engine oil and filter following the instructions provided in the engine manual packed with this manual.



WARNING! Never store the tractor with fuel in the tank indoors or in poorly ventilated enclosures, where fuel fumes may reach an open flame, spark or pilot light as on a furnace, water heater, clothes dryer, etc.

2. If storing the tractor for 30 days or more:
 - a. To prevent gum deposits from forming inside the engine's carburetor and causing possible malfunction of the engine, the fuel system must be either completely emptied, or the gasoline must be treated with a stabilizer to prevent deterioration.



WARNING! Fuel left in the fuel tank deteriorates and will cause serious starting problems.

- b. Using a fuel stabilizer such as **STA-BIL**® for storage between 30 and 90 days:
 - Read the product manufacturer's instructions and recommendations.
 - Add to clean, fresh gasoline the correct amount of stabilizer for the capacity (approximately 3 gallons) of the fuel system.
 - Fill the fuel tank with treated fuel and run the engine for 2-3 minutes to get stabilized fuel into the carburetor.
- c. Emptying the fuel system for storage of more than 90 days:
 - Prior to putting the tractor in storage, monitor fuel consumption with the goal of running the fuel tank empty.
 - Run the engine until it begins to stall. Use the choke to keep the engine running until all fuel in the carburetor has been exhausted.
 - Referring to the engine manual, drain the fuel from the carburetor bowl.

3. Clean the engine and the entire tractor thoroughly.
4. Fully charge the battery, then disconnect the negative cable at the battery to prevent possible discharge. Recharge the battery periodically when in storage.

NOTE: Remove the battery if exposed to prolonged periods of sub-freezing temperatures. Store in a cool, dry location where temperatures are above freezing.

5. Lubricate all lubrication points.

NOTE: Using a pressure washer or garden hose is not recommended for cleaning your tractor. It may cause damage to electrical components, spindles, pulleys, bearings or the engine. The use of water will result in shortened life and reduce serviceability.

Removing The Tractor From Storage

1. Check the engine oil.
2. Fully charge the battery and inflate the tires to the recommended pressure.
3. If drained before storing, fill the fuel tank with clean, fresh gasoline.
4. Add clean, fresh fuel.
5. Start the engine and allow to idle for a few minutes to ensure engine is operating properly.
6. Drive the tractor without a load to make certain all the tractor systems are functioning properly.

Hydrostatic Transmission

Your zero turn tractor is equipped with dual integrated hydrostatic pumps/transaxles that are sealed and are maintenance-free. However, this model is equipped with a transmission oil expansion reservoir. Under normal operating conditions, the oil level in the expansion reservoir does not need to be checked and no additional oil is needed. If checking the reservoir oil level, proceed as follows:

WARNING! Check the oil level **ONLY** before starting the tractor when the transmission oil is fully cooled.

1. Pivot the operator's seat forward and clean the reservoir cap and the area around the cap to prevent debris from contaminating the transmission oil. See Figure 6-1.

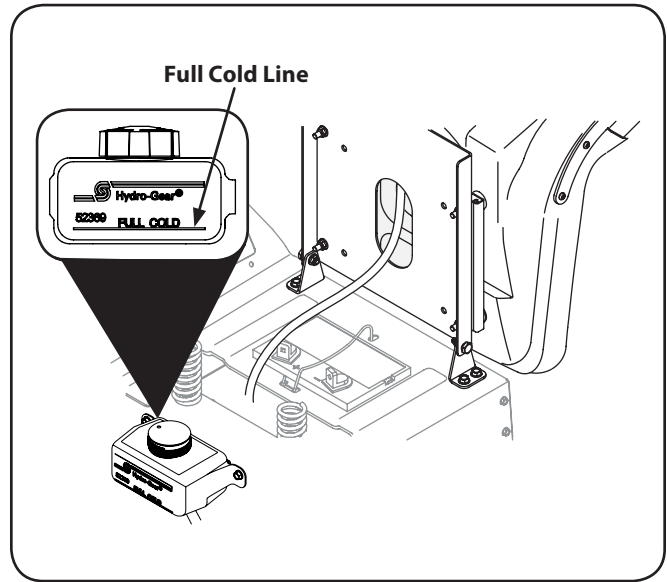

Figure 6-1

2. Turn the reservoir cap counterclockwise to re-move, then check the oil level in the reservoir. Oil should be visible at the bottom of the cup, but the oil level must **NOT** be above the "FULL COLD" line. See Figure 6-1. **DO NOT FILL THE RESERVOIR.**
3. If necessary to add oil because of some type of leakage, use a quality 20W50 motor oil and add only enough oil to bring the level to the "FULL COLD" line. Reinstall the cap and fully tighten.

Cleaning the Tractor

Any fuel or oil spilled on the machine should be wiped off promptly. Do **NOT** allow debris to accumulate around the cooling fins of the engine, the transmission's cooling fan or on any other part of the machine, especially the belts and pulleys.

Smart Jet™

Your tractor's deck is equipped with a water port on its surface as part of its deck wash system.

Use the Smart Jet™ to rinse grass clippings from the deck's underside and prevent the buildup of corrosive chemicals. Complete the following steps **AFTER EACH MOWING**:

1. Drive the tractor to a level, clear spot on your lawn, near enough for your garden hose to reach.



CAUTION: Make certain the tractor's discharge chute is directed **AWAY** from your house, garage, parked cars, etc.

1. Disengage the PTO (Blade Engage), set the parking brake and stop the engine.
2. Thread the hose coupler (packaged with your tractor's Operator's Manual) onto the end of your garden hose.

- Attach the hose coupler to the water port on your decks surface. See Figure 6-2.

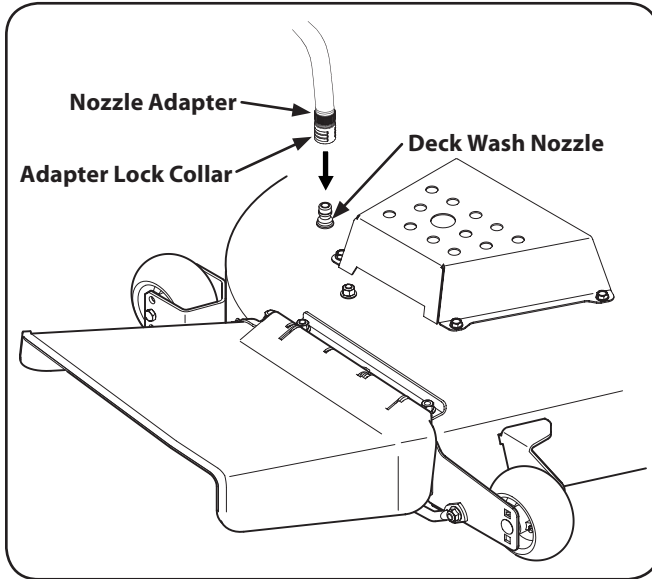



Figure 6-2

- Turn the water on.
- While sitting in the operator's position on the tractor, start the engine and place the throttle lever in the FAST  position.
- Move the tractor's PTO (Blade Engage) into the ON position.
- Remain in the operator's position with the cutting deck engaged for a minimum of two minutes, allowing the underside of the cutting deck to thoroughly rinse.
- Move the tractor's PTO (Blade Engage) into the OFF position.
- Turn the ignition key to the STOP position to turn the tractor's engine off.
- Turn the water off and detach the hose coupler from the water port on your deck's surface.
- Repeat step 4-10 on the opposite side of the cutting deck.

After cleaning your deck with the Smart Jet™ system, return to the operator's position and engage the PTO. Keep the cutting deck running for a minimum of two minutes, allowing the underside of the cutting deck to thoroughly dry.

Lubrication



WARNING! Before lubricating, repairing, or inspecting, always disengage PTO, set parking brake, stop engine and remove key to prevent unintended starting.

Front Wheels

Each of the front wheel spindles and rims is equipped with a grease fitting. See Figure 6-3. Lubricate with a No. 2 multi-purpose grease applied with a grease gun after every 25 hours of tractor operation.

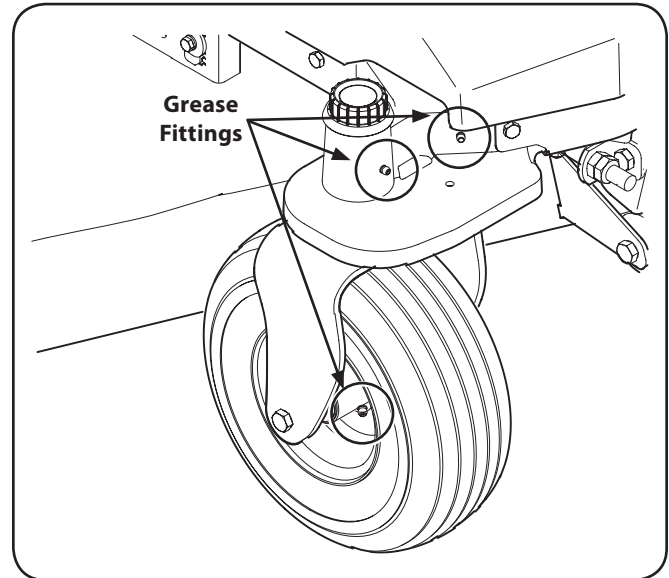

Figure 6-3

Pivot Points & Linkage

Lubricate all the pivot points on the drive system, parking brake and lift linkage at least once a season with light oil.

Deck Spindle

Grease fittings can be found on top of each spindle bolt. See Figure 6-4 for the Z-Force S60 and Figure 6-5 for the Z-Force S48. Lubricate with 251H EP grease or an equivalent No. 2 multi-purpose lithium grease. Using a grease gun, apply two strokes (minimum) or sufficient grease to the spindle shaft.

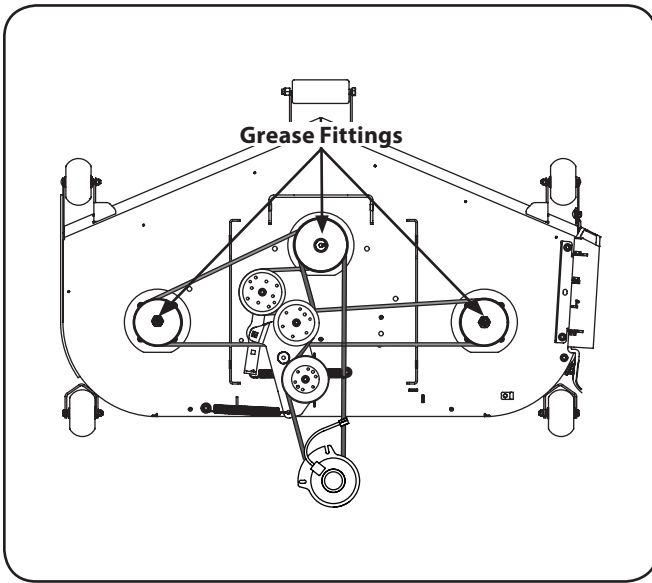

Figure 6-4

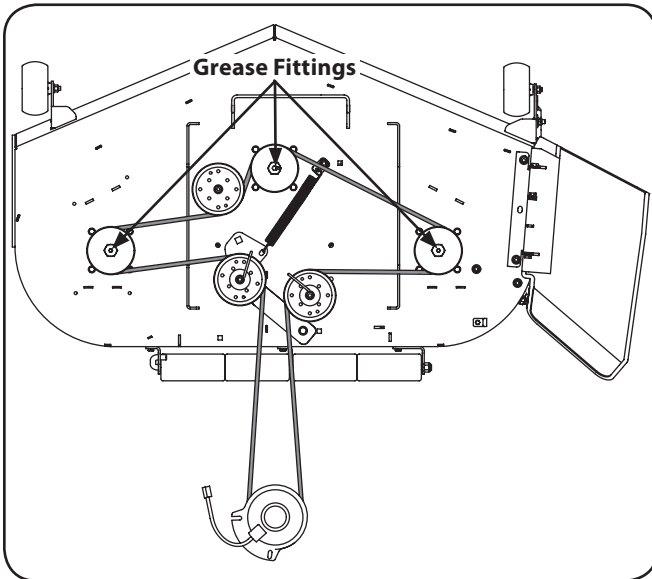

Figure 6-5

Tires



WARNING! Never exceed the maximum inflation pressure shown on the sidewall of the tire.

Refer to the tire sidewall for exact tire manufacturer's recommended or maximum psi. Do not overinflate. Uneven tire pressure could cause the cutting deck to mow unevenly.

Adjustments

NOTE: Check the tractor's tire pressure before performing any deck leveling adjustments. Refer to Tires on page 22 for information regarding tire pressure.



WARNING! Shut the engine off, remove the ignition key and engage the parking brake before making adjustments. Protect your hands by using heavy gloves when handling the blades.

Leveling the Deck (Side to Side)

NOTE: Check the tractor's tire pressure before performing any deck leveling adjustments. Refer to Tires for information regarding tire pressure. Always level the deck side to side before front to rear.

NOTE: When leveling the deck side-to-side, make sure the two rear adjustment gears are set in the middle of the adjustment range.

If the cutting deck appears to be mowing unevenly, a side to side adjustment can be performed. Adjust if necessary as follows:

1. With the tractor parked on a firm, level surface, place the deck lift pedal in a middle mowing position and rotate both outside blades so that they are perpendicular with the tractor.
2. Measure the distance from the outside of the left blade tip to the ground and the distance from the outside of the right blade tip to the ground. Both measurements taken should be equal. If they're not, proceed to the next step.
3. Loosen, but do NOT remove, the hex bolt on the front left deck hanger link. See Figure 6-6.

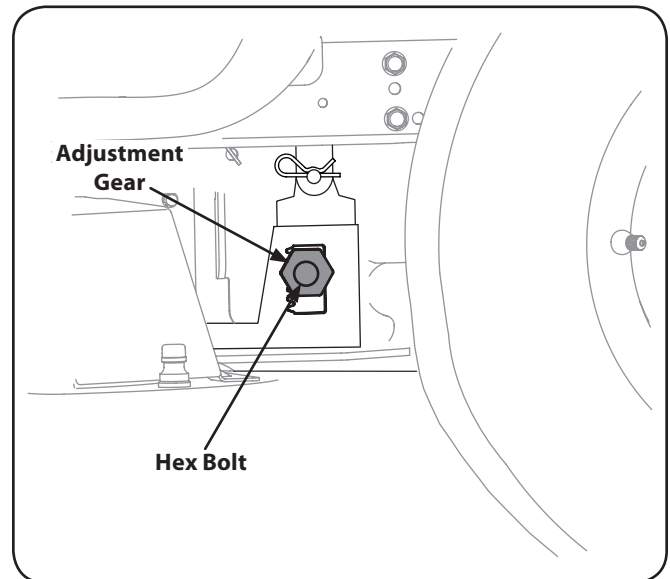

Figure 6-6

NOTE: The front right deck hanger link is not adjustable and is used to help adjust the other hanger links.

4. Using a wrench, raise or lower the left side of the deck by turning the adjustment gears. See Figure 6-6.

The deck is properly leveled when both blade tip measurements are equal. Retighten the hex bolt on the front left deck hanger bracket when proper adjustment is achieved.

Leveling the Deck (Front To Rear)

NOTE: Check the tractor's tire pressure before performing any deck leveling adjustments. Refer to Tires on page 22 for information regarding tire pressure. Always level the deck side to side before front to rear.

The front of the deck should be between $\frac{1}{4}$ " and $\frac{3}{8}$ " lower than the rear of the deck. Adjust if necessary as follows:

1. Park the tractor on a firm, level surface and place the deck lift pedal in a middle position.
2. Rotate the blade nearest the discharge chute so that it is parallel with the tractor.
3. Measure the distance from the front of the blade tip to the ground and the rear of the blade tip to the ground. The first measurement taken should be between $\frac{1}{4}$ " and $\frac{3}{8}$ " less than the second measurement.

Determine the approximate distance necessary for proper adjustment and proceed, if necessary.

4. Loosen, but do NOT remove, the hex bolt on the left and right rear deck hanger brackets. See Figure 6-6.
5. Using a wrench, raise or lower the left and right side of the deck by turning the adjustment gears. See Figure 6-6.
6. The deck is properly leveled when the front tip of the blade is $\frac{1}{4}$ " lower than the rear tip. Retighten the hex bolt on the left and right rear deck hanger links when proper adjustment is achieved.

Adjusting the Belt Tension

To tighten or loosen the tension on the belt, tighten or loosen the jam nuts on the U-rod, see Figure 6-7, until a ten-pound pull with a spring scale deflects the belt about $\frac{1}{2}$ ".

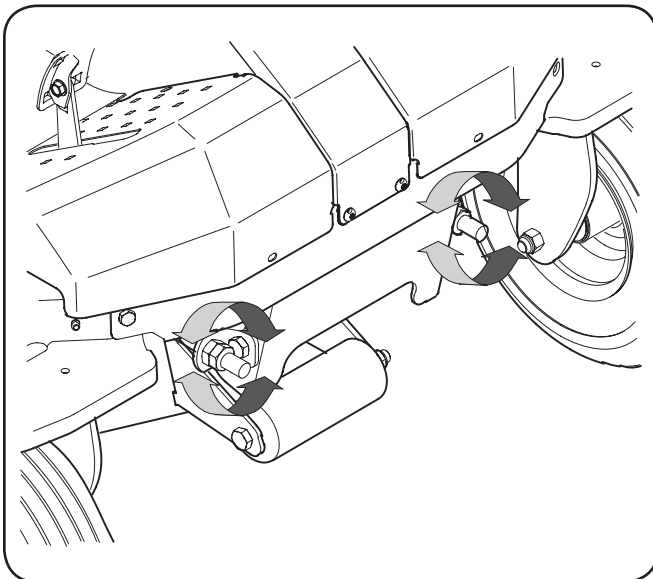

Figure 6-7

Setting the Deck Wheels

Move the tractor on a firm and level surface, preferably pavement, and proceed as follows

1. Select the height position of the cutting deck by placing the deck lift pedal in the normally desired mowing height setting.
2. Check the deck wheels for contact or excessive clearance with the surface below. The deck wheels should have between $\frac{1}{4}$ - $\frac{1}{2}$ " clearance above the ground.
3. If the deck wheels have excessive clearance or contact with the surface, adjust as follows:
 - a. Raise the deck lift pedal to its highest setting.
 - b. Remove the front and rear deck wheels by removing the lock nuts and shoulder bolts which secure them to the deck. See Figure 6-8.

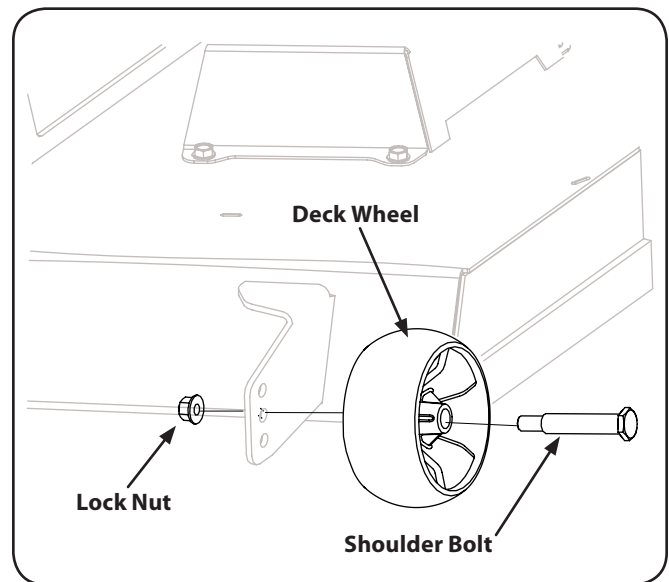

Figure 6-8

- c. Place the deck lift pedal in the desired mowing height setting.
- d. Reinsert the shoulder bolts (with each gauge wheel) into the index hole that leaves approximately $\frac{1}{2}$ -inch between the bottom of the wheel and the pavement.

Rear Deck Rollers

The rear deck rollers can be placed in two positions. To change the height of the rear deck rollers Refer to Figure 6-9 and proceed as follows:

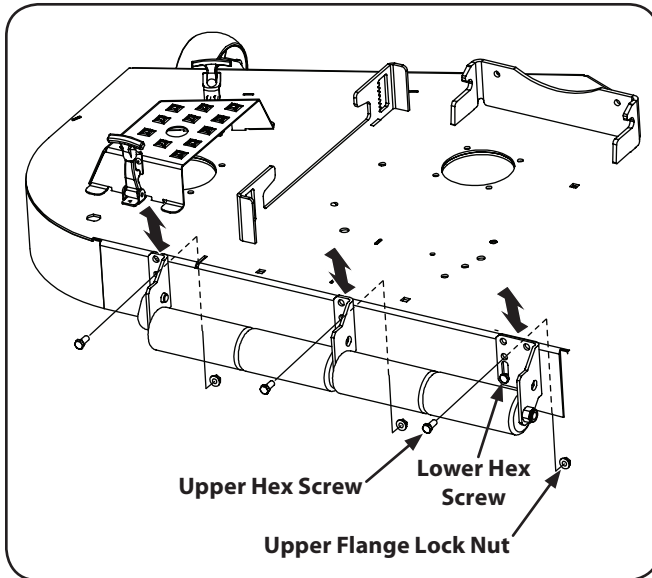

Figure 6-9

1. Loosen — but do not remove — the lower hex screws and lower flange lock nuts on all three brackets securing the rollers to the deck.
NOTE: The brackets are slotted on the lower half of the bracket to allow the deck rollers to be moved up and down.
2. Remove the upper hex screws and upper flange lock nuts from the brackets and the deck.
NOTE: In the highest position the upper hex screws and flange lock nuts are in the hole directly above the slots, in the lowest position the upper hex screws and flange lock nuts are in the uppermost hole.
3. Move the brackets into the desired position and re-install, but do not tighten the upper hex screws and flange lock nuts through brackets and the deck.
4. Tighten the lower hex screws and flange lock nuts and then tighten the lower hex screws and flange lock nuts.

Parking Brake Adjustment

If the tractor does not come to a complete stop when the brake lever is completely engaged, or if the tractor's rear wheels can roll with the parking brake applied (and the hydrostatic relief valve open), the brake is in need of adjustment. See your Cub Cadet dealer to have the brake properly adjusted.



WARNING! Before performing any service, place the PTO switch in the “OFF” position, engage the parking brake lever, turn the ignition key to the “OFF” position and remove the key from the switch.

Battery Removal



WARNING! Battery posts, terminals and related accessories contain lead and lead compounds. Wash hands after handling.

The battery is located beneath the seat frame. To remove the battery:

1. Push down and back on the battery hold-down bracket as shown in Figure 7-1 to free it from the seat mount frame.

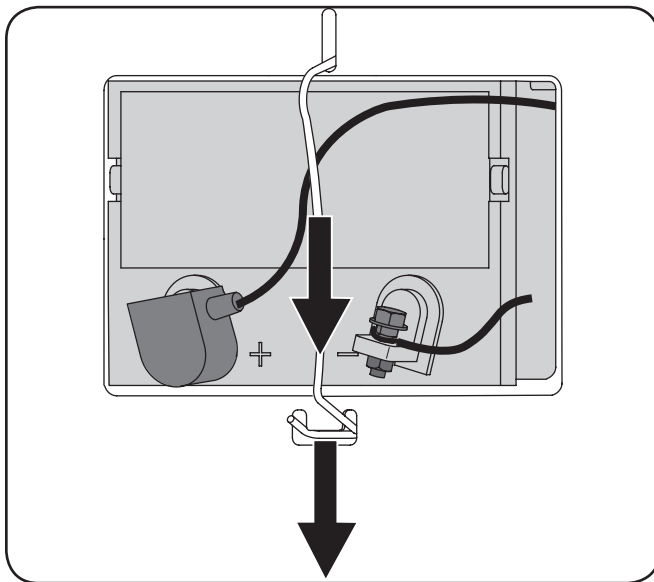

Figure 7-1

2. Remove the hex cap screw and sems nut securing the black negative battery lead to the negative battery post (marked NEG). Move the cable away from the negative battery post.
3. Remove the hex cap screw and sems nut securing the red positive battery lead to the positive battery post (marked POS).
4. Carefully lift the battery out of the tractor.
5. Install the battery by repeating the above steps in the reverse order.



WARNING! Always connect the positive lead to the battery before connecting the negative lead. This will prevent sparking or possible injury from an electrical short caused by contacting the tractor body with tools being used to connect the cables.

Charging the Battery

Test and, if necessary, recharge the battery after the tractor has been stored for a period of time.

- A voltmeter or load tester should read 12.6 volts (DC) or higher across the battery terminals. See Figure 7-2.

| Voltmeter Reading | State of Charge | Charging Time |
|-------------------|-----------------|---------------|
| 12.7 | 100% | Full Charge |
| 12.4 | 75% | 90 Min. |
| 12.2 | 50% | 180 Min. |
| 12.0 | 25% | 280 Min. |

Figure 7-2

- Charge the battery with a 12-volt battery charger at a MAXIMUM rate of 10 amps.

Servicing Electrical System

A fuse is installed to protect the tractor’s electrical system from damage caused by excessive amperage. Always use the same capacity fuse for replacement. If the electrical system does not function, check for a blown fuse.

If you have a recurring problem with blown fuses, have the tractor’s electrical system checked by your Cub Cadet Service Dealer.

Relays and Switches

There are several safety switches in the electrical system. If a function of the safety interlock system described earlier is not functioning properly, have the electrical system checked by your Cub Cadet Service Dealer.

Deck Removal

Remove the mower deck from the tractor as follows:

1. Move the tractor to a level surface, disengage the PTO, stop the engine, and set the parking brake.
2. Remove the lock rod by pressing the pedal forward to release tension then rotate the lock rod until the end of the rod points upward and slide it out of the deck height bracket. See Figure 7-3.

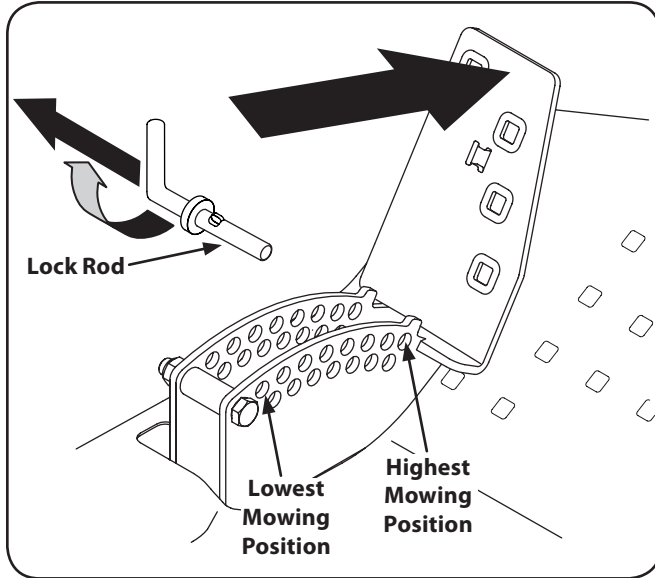

Figure 7-3

3. Place the deck lift pedal in the lowest mowing position and replace the lock rod in front of pedal in the deck height bracket and secure by rotating the lock rod until the end of the rod points downward.
4. Using a 1/2" drive in the idler assembly turn the wrench towards the back of the tractor and slide the belt off the PTO pulley. See Figure 7-4 for the Z-Force S60 and Figure 7-5 for the Z-Force S48.

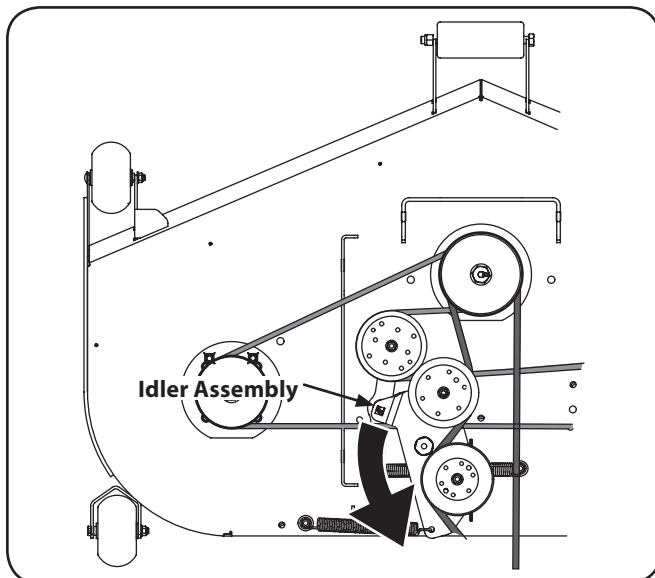

Figure 7-4

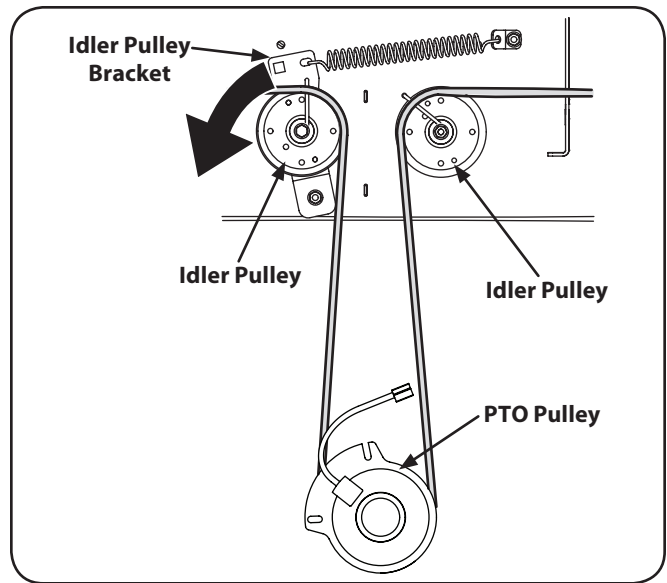

Figure 7-5

5. Once the belt is off the PTO pulley, slide the deck forward and unhook the U-Rod at the nose of the deck.
6. Pull the cotter pins out of the four deck lift adjustment brackets. See Figure 7-6.

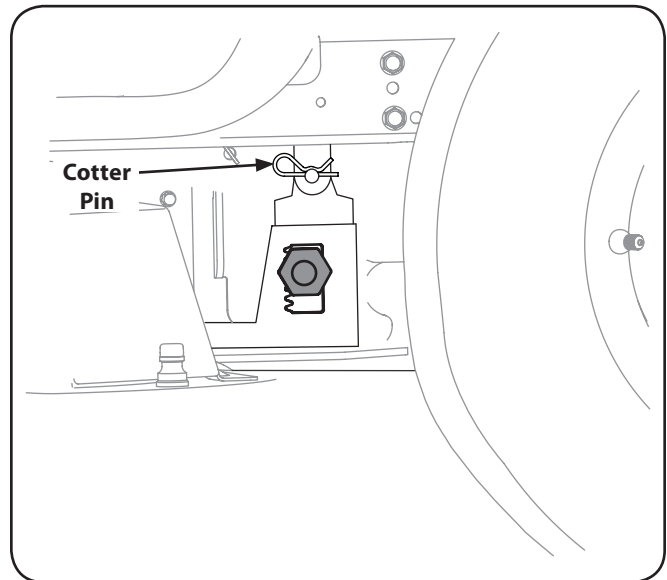

Figure 7-6



CAUTION: The deck lift helper springs will cause the deck lift pedal to slam to the highest position if the click pin is not in front of the pedal.

7. Slide the links off the pins and then slide the deck out from underneath the tractor to the right side.

NOTE: It may be easier to place the deck lift pedal in the transport position when sliding the deck out from underneath the tractor.

Deck Installation

Install the deck on the tractor as follows:

1. Place the deck lift pedal in the highest mowing position and secure it by placing the lock rod behind the pedal. See Figure 7-3.
2. Slide the deck under the tractor on the right side of the tractor lining up the deck lift adjustment brackets and the deck lift brackets on the deck. See Figure 7-7.

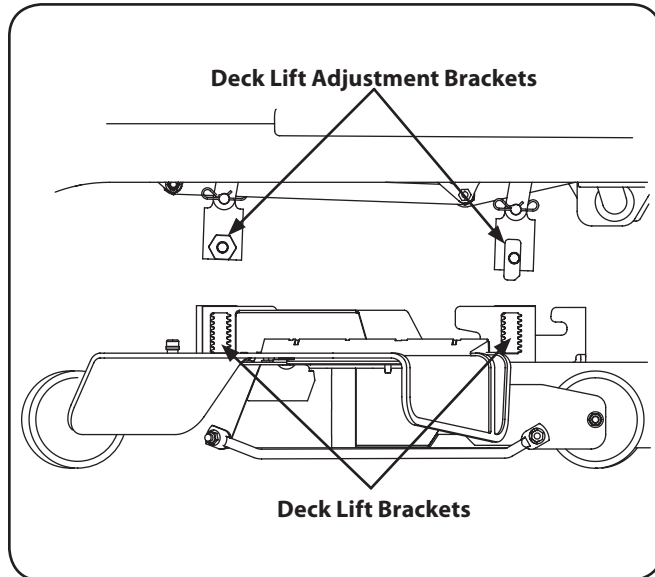

Figure 7-7

3. Once the deck is under the tractor, move the deck lift pedal to the lowest mowing position.

NOTE: To line the brackets up properly, it may be necessary to place a small block of wood under each side of the deck.
4. Once the brackets are properly aligned, slide the pin on the deck lift adjustment bracket into the lift bracket and secure with cotter pins. See Figure 7-8.

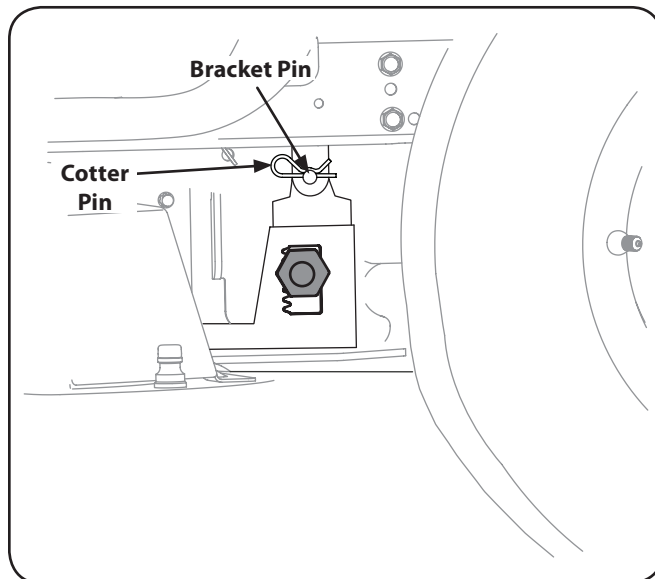

Figure 7-8

5. After all four cotter pins are secure, slide the deck forward and hook the deck to the U-rod.
6. Route the belt as shown in Figure 7-9 for Z-Force S60 and Figure 7-10 for the Z-Force S48. After routing the belt around the PTO pulley, use a ½" drive in the idler pulley bracket and turn towards the front of the tractor to finish routing the belt around the idler pulley.

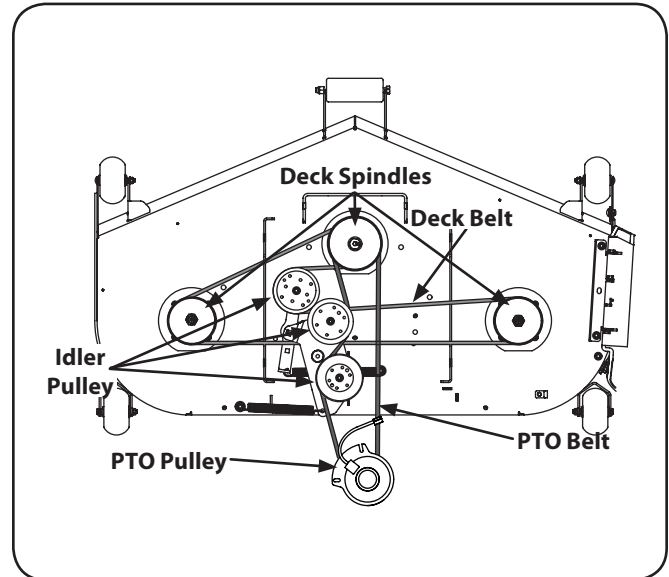

Figure 7-9

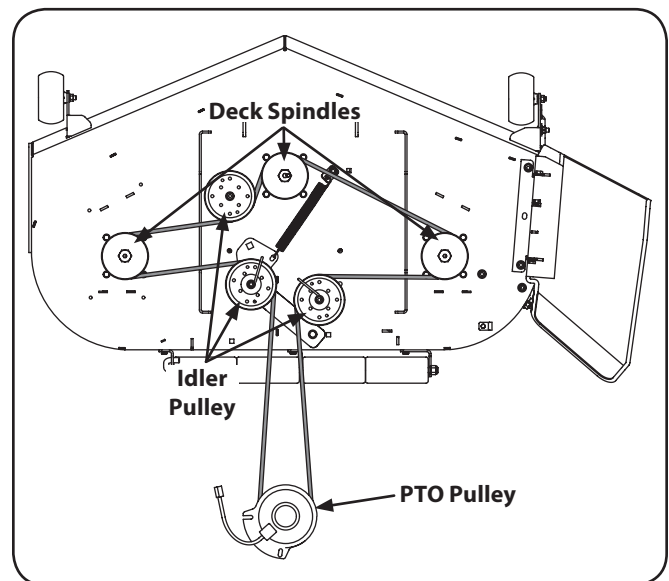

Figure 7-10

7. Place the deck in the highest mowing position by removing the click pin and push the pedal forward and rock back to lock into the transport position, locking behind the notch on the front of the index plate.
8. Refer to the Maintenance & Adjustments section to level the deck if required.
9. Make sure the proper tension is on the belt. To adjust the tension, refer to "Adjusting Belt Tension" on page 23.

NOTE: Before using the tractor double-check the belt routing to make sure that the belt has been routed properly.

Replacing the Belt

1. Remove the deck from beneath the tractor, (refer to Deck Removal on page 26).
2. Pull the four draw latches up and away from the deck covers to unlatch and remove both covers. See Figure 7-11 for the Z-Force S60 and Figure 7-12 for the Z-Force S48.

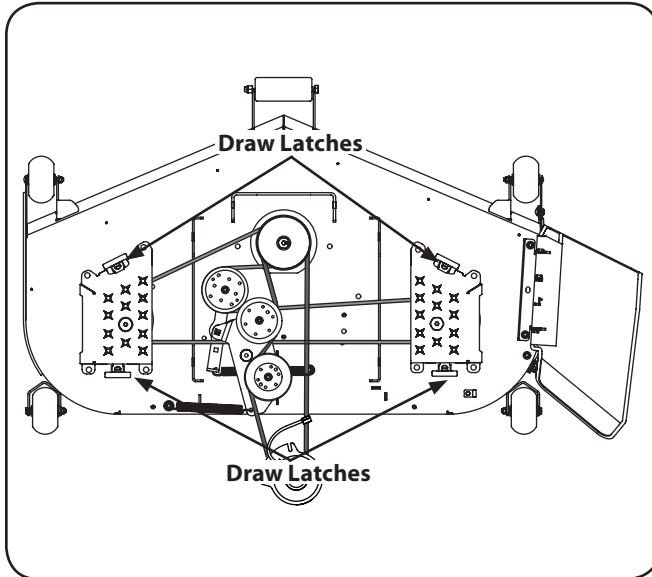

Figure 7-11

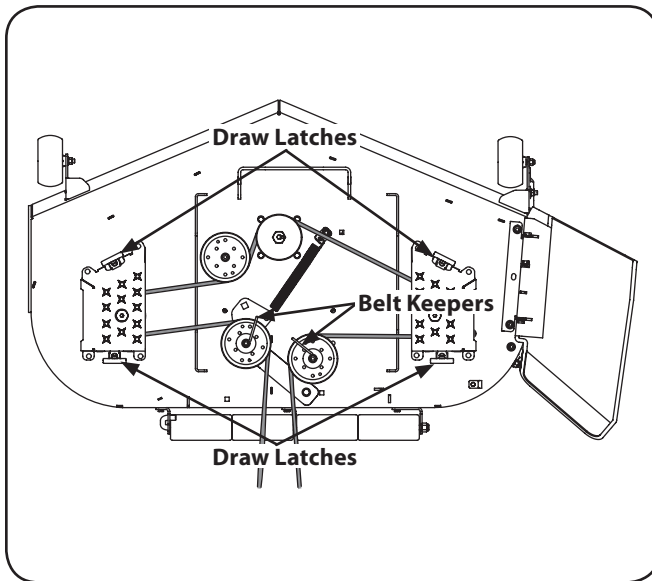

Figure 7-12

3. Remove the belt from the deck spindles. Refer to Figure 7-9 for Z-Force S60 and Figure 7-10 for the Z-Force S48.
4. Install the new belt around the spindle pulleys as shown in Figure 7-9 for Z-Force S60 and Figure 7-10 for the Z-Force S48 and reinstall the belt covers.
5. Reinstall the deck following the instructions in Deck Installation on page 27.

Mower Blade Care



WARNING! Protect your hands by using heavy gloves when handling the blades. When servicing the mower deck, be careful not to cut yourself on the sharpened blades.

The cutting blades must be kept sharp at all times. Sharpen the cutting edges of the blades evenly so that the blades remain balanced and the same angle of sharpness is maintained.

If the cutting edge of a blade has already been sharpened many times, or if any metal separation is present, it is recommended that new blades be installed. New blades are available at your authorized dealer.

The blades may be removed as follows.

1. Remove the deck from beneath the tractor, (refer to Deck Removal on page 26) then gently flip the deck over to expose its underside.
2. Use a $\frac{3}{4}$ " wrench to hold the hex nut on top of the spindle assembly when loosening the hex nut securing the blade. See Figure 7-13.

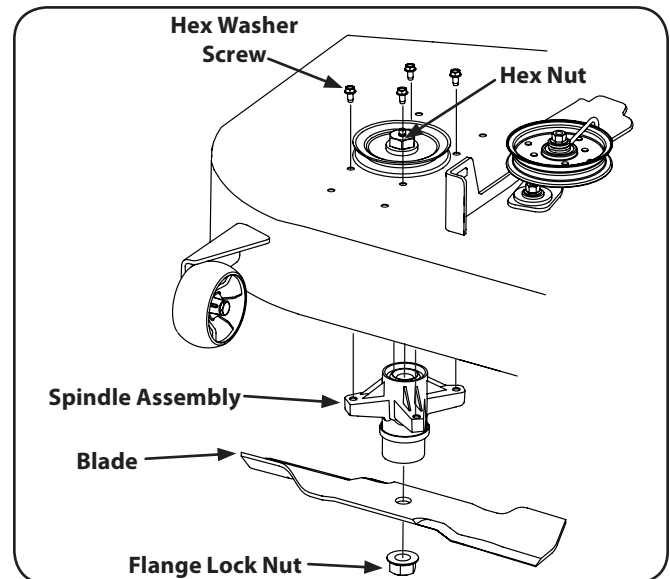

Figure 7-13

3. A block of wood may be placed between the deck housing and the cutting edge of the blade to help in breaking loose the hex nut securing the blade.
4. To reinstall the blades, reverse the above process and tighten nut to 100-120 lb. ft.
5. Reinstall the deck (refer to Deck Installation on page 27).

NOTE: Add a small amount of multi-purpose grease to the bolt threads to avoid corrosion and galvanic action.



WARNING!: Never mow with dull blades. Blades that are bent should be replaced. The cutting blades are sharp and can cause severe injury. Wrap the cutting surface of the blade with a rag to avoid injury.

Sharpening the Blades

1. Remove the deck from beneath the tractor, (refer to Deck Removal on page 26) then gently flip the deck over to expose its underside.
1. Clean any debris from the blades. Keep blades sharp and free of build up at all times.
2. Sharpen blades evenly at the original 30° angle to maintain balanced cutting blades. Do not sharpen the underside of the blades. Use a electric blade sharpener, a conventional electric grinder or a hand file to sharpen the blades.
3. Replace any blade with severe nicks or dents that cannot be removed by filing.
4. Check the balance of the blade after sharpening by placing it on a blade balancer. Do not use unbalanced blades.
5. If the blade dips on one end, file stock off of the cutting surface on that end.

NOTE: Blades that cannot be easily balanced — REPLACE.

Changing the Spindle Assembly

1. Remove the deck from beneath the tractor, (refer to Deck Removal on page 26).
2. Remove the hex washer screws securing the belt covers to the deck and remove the belt from the spindle pulleys. Refer to Figure 7-13.
1. Remove the drive belt. (See Replacing the Belt)
2. Remove the blade. (See Mower Blade Care).
3. Use a $\frac{3}{4}$ " wrench to hold the hex nut on top of the spindle assembly when loosening the hex nut securing the blade. A block of wood may be placed between the deck housing and the cutting edge of the blade to help in breaking loose the hex nut securing the blade. See Figure 7-14.

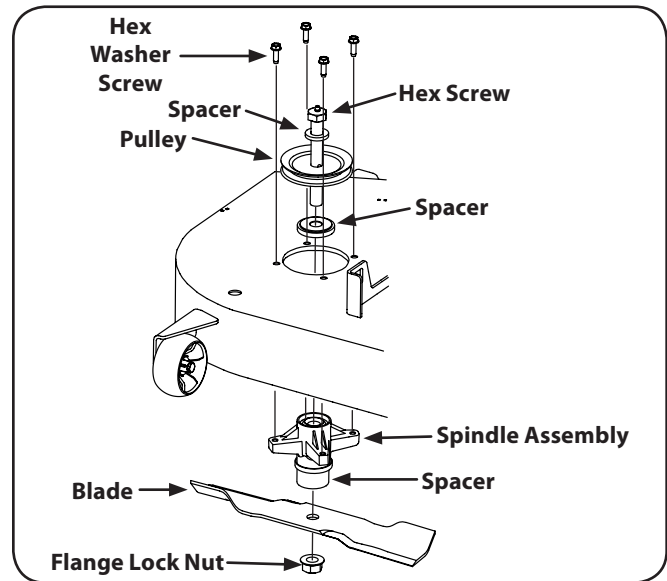

Figure 7-14



NOTE: Take note of the order that the parts composing the assembly are placed.



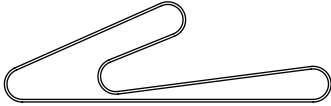
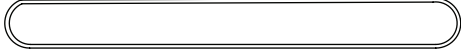
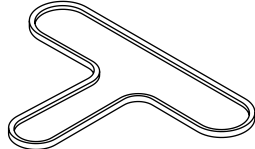
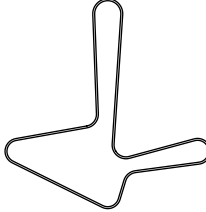
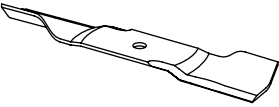
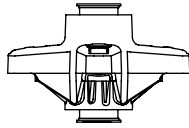

4. Using a wrench or socket ratchet remove four hex washer screws. Remove the spindle assembly. See Figure 7-14.
5. Reverse the process to install the spindle assembly.

Changing the Transmission Drive Belt

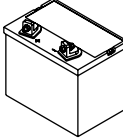
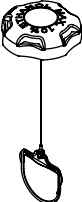
Several components must be removed and special tools used in order to change the tractor's transmission drive belt. See your Cub Cadet dealer to have the transmission drive belt replaced.

| Problem | Cause | Remedy |
|--|---|---|
| Excessive vibration | <ol style="list-style-type: none"> 1. Cutting blade loose or unbalanced. 2. Damaged or bent cutting blade. | <ol style="list-style-type: none"> 1. Tighten blade and spindle. 2. Replace blade. |
| Uneven cut | <ol style="list-style-type: none"> 1. Deck not leveled properly. 2. Dull blade. 3. Uneven tire pressure. | <ol style="list-style-type: none"> 1. Perform side-to-side deck adjustment. 2. Sharpen or replace blade. 3. Check tire pressure in all four tires. |
| Mower will not mulch grass (If Equipped w/Mulching Kit) | <ol style="list-style-type: none"> 1. Engine speed too low. 2. Wet grass. 3. Excessively high grass. 4. Dull blade. | <ol style="list-style-type: none"> 1. Place throttle in FAST position. 2. Do not mulch when grass is wet. 3. Mow once at a high cutting height, then mow again at desired height or make a narrower cutting swath. 4. Sharpen or replace blade. |

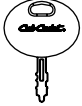
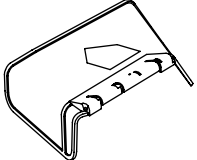
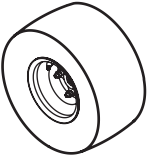
| Component | Part Number and Description |
|---|--|
|  | 01005376 Deck Belt (Z-Force S60) |
|  | 954-04262 PTO Belt (Z-Force S60) |
|  | 954-3092A Drive Belt |
|  | 954-04044A Deck Belt (Z-Force S48) |
|  | 942-04415 Mowing Blade (Z-Force S60) 942-04417 Mowing Blade (Z-Force S48) |
|  | 918-3129C Deck Spindle |
|  | 634-3159 Deck Wheel (Z-Force S60) 734-04155 Deck Wheel (Z-Force S48) |
|  | 925-1707D Battery |
|  | 951-12193A Gas Cap |

| Component | Part Number and Description |
|---|--------------------------------------|
|  | 946-1086 Throttle Control Cable |
|  | 946-04752 Choke Control Cable |
|  | 925-2054A Ignition Key |
|  | 01006693P Chute Deflector |
|  | 634-04698 Wheel Assembly |
|  | 634-04623 Caster Wheel Assembly |

| Part No. | Part |
|---------------|---------------------------|
| 19A70011100 * | 48" Triple Bagger |
| 19A70012100 * | 60" Triple Bagger |
| 59A30034150 | Twin Bagger, Power Assist |
| 59A30034150 | Power Assist Twin Bagger |
| 19A70018100 | Headlight Kit |
| 19A70016100 | Mulch Kit (Z-Force S48) |
| 19A70017100 | Mulch Kit (Z-Force S460) |
| 19A70024100 | 58" Snow Blade |
| OEM-190-784 | Wheel Weights |
| 490-850-0005 | Blade Removal Tool |
| 490-850-0008 | Oil Siphon |

* — Recommended for residential use only

FEDERAL and/or CALIFORNIA EMISSION CONTROL WARRANTY STATEMENT
YOUR WARRANTY RIGHTS AND OBLIGATIONS

MTD Consumer Group Inc, the United States Environmental Protection Agency (EPA), and, for those products certified for sale in the state of California, the California Air Resources Board (CARB) are pleased to explain the emission (evaporative and/or exhaust) control system (ECS) warranty on your outdoor 2006 and later small off-road spark-ignited engine and equipment (outdoor equipment engine) In California, new outdoor equipment engines must be designed, built and equipped to meet the State's stringent anti-smog standards (in other states, 1997 and later model year equipment must be designed, built, and equipped to meet the U.S. EPA small off-road, spark ignition engine regulations. MTD Consumer Group Inc must warrant the ECS on your outdoor equipment engine for the period of time listed below provided there has been no abuse, neglect or improper maintenance of outdoor equipment engine.

Your ECS may include parts such as the carburetor, fuel-injection system, the ignition system, catalytic converter, fuel tanks, fuel lines, fuel caps, valves, canisters, filters, vapor hoses, clamps, connectors, and other associated emission-related components.

Where a warrantable condition exists, MTD Consumer Group Inc will repair your outdoor equipment engine at no cost to you including diagnosis, parts and labor.

MANUFACTURER'S WARRANTY COVERAGE:

This emission control system is warranted for two years. If any emission-related part on your outdoor equipment engine is defective, the part will be repaired or replaced by MTD CONSUMER GROUP INC.

OWNER'S WARRANTY RESPONSIBILITIES:

As the outdoor equipment engine owner, you are responsible for performance of the required maintenance listed in your owner's manual. MTD Consumer Group Inc recommends that you retain all receipts covering maintenance on your outdoor equipment engine, but MTD Consumer Group Inc cannot deny warranty solely for the lack of receipts.

As the outdoor equipment engine owner, you should however be aware that MTD Consumer Group Inc may deny you warranty coverage if your outdoor equipment engine or a part has failed due to abuse, neglect, or improper maintenance or unapproved modifications.

You are responsible for presenting your outdoor equipment engine to MTD Consumer Group Inc's distribution center or service center as soon as the problem exists. The warranty repairs should be completed in a reasonable amount of time, not to exceed 30 days. If you have a question regarding your warranty coverage, you should contact the MTD Consumer Group Inc Service Department at 1-800-800-7310 or via email at <http://support.mtdproducts.com>

GENERAL EMISSIONS WARRANTY COVERAGE:

MTD Consumer Group Inc warrants to the ultimate purchaser and each subsequent purchaser that the outdoor equipment engine is: Designed, built and equipped so as to conform with all applicable regulations; and free from defects in materials and workmanship that cause the failure of a warranted part to be identical in all material respects to that part as described in MTD Consumer Group Inc's application for certification.

The warranty period begins on the date the outdoor equipment engine is delivered to an ultimate purchaser or first placed into service. The warranty period is two years.

Subject to certain conditions and exclusions as stated below, the warranty on emission-related parts is as follows:

1. Any warranted part that is not scheduled for replacement as required maintenance in the written instructions supplied, is warranted for the warranty period stated above. If the part fails during the period of warranty coverage, the part will be repaired or replaced by MTD Consumer Group Inc according to subsection (4) below. Any such part repaired or replaced under warranty will be warranted for the remainder of the period.
 2. Any warranted part that is scheduled only for regular inspection in the written instructions supplied is warranted for the warranty period stated above. Any such part repaired or replaced under warranty will be warranted for the remaining warranty period.
 3. Any warranted part that is scheduled for replacement as required maintenance in the written instructions supplied is warranted for the period of time before the first scheduled replacement date for that part. If the part fails before the first scheduled replacement, the part will be repaired or replaced by MTD Consumer Group Inc according to subsection (4) below. Any such part repaired or replaced under warranty will be warranted for the remainder of the period prior to the first scheduled replacement point for the part.
 4. Repair or replacement of any warranted part under the warranty provisions herein must be performed at a warranty station at no charge to the owner.
 5. Notwithstanding the provisions herein, warranty services or repairs will be provided at all of our distribution centers that are franchised to service the subject engines or equipment.
 6. The outdoor equipment engine owner will not be charged for diagnostic labor that is directly associated with diagnosis of a defective, emission-related warranted part, provided that such diagnostic work is performed at a warranty station.
 7. MTD Consumer Group Inc is liable for damages to other engine or equipment components proximately caused by a failure under warranty of any warranted part.
 8. Throughout the off-road engine and equipment warranty period stated above, MTD Consumer Group Inc will maintain a supply of warranted parts sufficient to meet the expected demand for such parts.
 9. Any replacement part may be used in the performance of any warranty maintenance or repairs and must be provided without charge to the owner. Such use will not reduce the warranty obligations of MTD Consumer Group Inc.
-

-
10. Add-on or modified parts that are not exempted by the Air Resources Board may not be used. The use of any non-exempted add-on or modified parts by the ultimate purchaser will be grounds for disallowing a warranty claims. MTD Consumer Group Inc will not be liable to warrant failures of warranted parts caused by the use of a non-exempted add-on or modified part.

WARRANTED PARTS:

The repair or replacement of any warranted part otherwise eligible for warranty coverage may be excluded from such warranty coverage if MTD Consumer Group Inc demonstrates that the outdoor equipment engine has been abused, neglected, or improperly maintained, and that such abuse, neglect, or improper maintenance was the direct cause of the need for repair or replacement of the part. That notwithstanding, any adjustment of a component that has a factory installed, and properly operating, adjustment limiting device is still eligible for warranty coverage. Further, the coverage under this warranty extends only to parts that were present on the off-road engine and equipment purchased.

The following emission warranty parts are covered (if applicable):

1. Fuel Metering System
 - Cold start enrichment system (soft choke)
 - Carburetor and internal parts (or fuel injection system)
 - Fuel pump
 - Fuel tank
2. Air Induction System
 - Air cleaner
 - Intake manifold
3. Ignition System
 - Spark plug(s)
 - Magneto ignition system
4. Exhaust System
 - Catalytic converter
 - SAI (Reed valve)
5. Miscellaneous Items Used in Above System
 - Vacuum, temperature, position, time sensitive valves and switches
 - Connectors and assemblies
6. Evaporative Control
 - Fuel hose
 - Fuel hose clamps
 - Tethered fuel cap
 - Carbon canister
 - Vapor lines

CUB CADET LLC
MANUFACTURER'S LIMITED WARRANTY FOR
Z-FORCE COMMERCIAL ZERO-TURN COMMERCIAL RIDING MOWERS

IMPORTANT: To obtain warranty coverage owner must present an original proof of purchase and applicable maintenance records to the servicing dealer. Please see the operator's manual for information on required maintenance and service intervals.

The limited warranty set forth below is given by Cub Cadet LLC with respect to new merchandise purchased or leased and used in the United States and/or its territories and possessions, and by MTD Products Limited with respect to new merchandise purchased or leased and used in Canada and/or its territories and possessions (either entity respectively, "Cub Cadet").

Cub Cadet warrants this product (excluding its *Normal Wear Parts, Batteries and Attachments* as described below) against defects in material and workmanship for a period of two (2) years commencing on the date of original retail purchase or lease and will, at its option, repair or replace, free of charge, any part found to be defective in materials or workmanship.

Normal Wear Parts are warranted to be free from defects in material and workmanship for a period of thirty (30) days or one hundred (100) operation hours, whichever comes first, commencing on the date of original retail purchase or lease. Normal wear parts include, but are not limited to items such as: belts, blades, blade adapters, grass bags, rider deck wheels, seats, and tires.

Batteries have a one-year prorated limited warranty against defects in material and workmanship, with 100% replacement during the first three months. After three months, the battery replacement credit is based on the months remaining in the twelve (12) month period dating back to the original date of original sale or lease. Any replacement battery will be warranted only for the remainder of the original warranty period.

Attachments — Cub Cadet warrants attachments for this product against defects in material and workmanship for a period of one (1) year, commencing on the date of the attachment's original purchase or lease. Attachments include, but are not limited to items such as: grass collectors and mulch kits.

This limited warranty shall only apply if this product has been operated and maintained in accordance with the Operator's Manual furnished with the product, and has not been subject to misuse, abuse, neglect, accident, improper maintenance, alteration, vandalism, theft, fire, water, or damage because of other peril or natural disaster. Damage resulting from the installation or use of any part, accessory or attachment not approved by Cub Cadet for use with the product(s) covered by this manual will void your warranty as to any resulting damage. In addition, Cub Cadet may deny warranty coverage if the hour meter, or any part thereof, is altered, modified, disconnected or otherwise tampered with.

HOW TO OBTAIN SERVICE: Warranty service is available, WITH PROOF OF PURCHASE AND APPLICABLE MAINTENANCE RECORDS, through your local authorized service dealer. To locate the dealer in your area:

In the U.S.A.:

Check your Yellow Pages, or contact Cub Cadet LLC at P.O. Box 361131, Cleveland, Ohio 44136-0019, call 1-877-282- 8684 or log on to our website at www.cubcadet.com.

In Canada:

Contact MTD Products Limited, Kitchener, ON N2G 4J1, call 1-800-668-1238 or log on to our website at www.mtdcanada.com.

Without limiting the foregoing, this limited warranty does not provide coverage in the following cases:

- a. Routine maintenance items such as lubricants, filters, blade sharpening, tune-ups, brake adjustments, clutch adjustments, deck adjustments, and normal deterioration of the exterior finish due to use or exposure.
- b. Service completed by someone other than an authorized service dealer.
- c. Cub Cadet does not extend any warranty for products sold or exported outside of the United States and/or Canada, and their respective possessions and territories, except those sold through Cub Cadet's authorized channels of export distribution.
- d. Replacement parts and/or accessories that are not genuine Cub Cadet parts.
- e. Transportation charges and service calls.

There are no implied warranties, including without limitation any implied warranty of merchantability or fitness for a particular purpose. No warranties shall apply after the applicable period of express written warranty above. No other express warranties beyond those mentioned above, given by any person or entity, including a dealer or retailer, with respect to any product, shall bind Cub Cadet. The exclusive remedy is repair or replacement of the product as set forth above. The terms of this warranty provide the sole and exclusive remedy arising from the sale and/or lease of the products covered hereby. Cub Cadet shall not be liable for any incidental or consequential loss or damage including, without limitation, expenses incurred for substitute or replacement lawn care services or for rental expenses to temporarily replace a warranted product.

Some jurisdictions do not allow the exclusion or limitation of incidental or consequential damages, or limitations on how long an implied warranty lasts, so the above exclusions or limitations may not apply to you.

In no event shall recovery of any kind be greater than the amount of the purchase price of the product sold. **Alteration of safety features of the product shall void this warranty.** You assume the risk and liability for loss, damage, or injury to you and your property and/or to others and their property arising out of the misuse or inability to use the product.

This limited warranty shall not extend to anyone other than the original purchaser or to the person for whom it was purchased as a gift.

HOW LOCAL LAWS RELATE TO THIS WARRANTY: This limited warranty gives you specific legal rights, and you may also have other rights that vary in different jurisdictions.

Cub Cadet LLC, P.O. BOX 361131 CLEVELAND, OHIO 44136-0019, Phone: 1-877-282-8684
MTD Products Limited, Kitchener, ON N2G 4J1, Phone: 1-800-668-1238