

Clariflo® *PUMP*



SUBMERSIBLE PUMP HSE RANGE

OPERATION & MAINTENANCE
INSTRUCTIONS



0806



SPECIFICATIONS

Model No.	HSE120*	HSE200	HSE300* / HSE301	HSE360* / HSE361	HSEC400*
Outlet Dia. (mm/inches)	32/1-1/4"	38/1-1/2"	50/2"	50/2"	50/2"
Motor Voltage	230V 50Hz	230V 50Hz	230V 50Hz 115V 50Hz	230V 50Hz 115V 50Hz	230V 50Hz
Motor Wattage (W)	320	420	720 720	960 960	720
Max. Head (M)	7	10	10	10	8
Max. Flow Rate (L/min)	160	200	300	360	240
Max. Solids Diameter(mm)	5	25	30	30	10
Dimensions LxWxH (mm)	180x130x210	197x135x314	225x141x350 230x141x350	225x141x365 230x141x365	230x170x240
Cable (Max. mm ²)	10x1.00	10x1.00	10x1.00	10x1.00	10x1.00

* Includes the automatic (A) version



Please read these instructions carefully before operating the tool

Thank you for purchasing this **CLARKE** Submersible Pump. These pumps are ideal for draining ponds, pools and building excavations, these heavy duty pumps can handle small solids in suspension. Before using the device, please read this manual thoroughly and carefully follow all instructions given. This is for your own safety and that of others around you, and is also to help you achieve long and trouble free service from your new tool.

CLARKE GUARANTEE

This CLARKE product is guaranteed against faulty manufacture for a period of 12 months from the date of purchase. Please keep your receipt as proof of purchase.

This guarantee is invalid if the product is found to have been abused or tampered with in any way, or not used for the purpose for which it was intended.

Faulty goods should be returned to their place of purchase, no product can be returned to us without prior permission.

This guarantee does not affect your statutory rights.

PARTS & SERVICE TEL: 020 8988 7400

or e-mail as follows:

PARTS: Parts@clarkeinternational.com

SERVICE: Service@clarkeinternational.com

Please note that the details and specifications contained herein are correct at the time of going to print. However CLARKE International reserve the right to change specifications at any time without prior notice. Always consult the machines data plate

SAFETY PRECAUTIONS



WARNING:



As with all machinery, there are certain hazards involved with their operation and use. Exercising respect and caution will considerably lessen the risk of personal injury. However, if normal safety precautions are overlooked or ignored, personal injury to the operator even damage to the pump or property, may result. For your own safety and that of others around you, please read these safety instructions in conjunction with the operating instructions, and before using the pump.

- These pumps are designed to pump **Water Only**. **NEVER** use for pumping flammable liquids or chemicals of any kind.
- An approved Residual Current Device (RCD) **MUST** be used when pumping from ponds or swimming pools.
- Your submersible pump may **ONLY** be used for pumping water from a swimming pool when there is no person or animal in the pool.
- If the water is likely to freeze, the pump **MUST** be run continuously, otherwise the pump must be removed from the water and stored in a frost free location.
- If the pump is to be used where there may be silt or mud etc (e.g., garden ponds), keep the pump clear of any sediment by standing it on a platform or brick or suspending from a rope attached to the handle.
- **NEVER** run the pump dry.
- **NEVER** run the pump with the body exposed for longer than 10 minutes.
- **NEVER** install the pump on sand, silt, mud or ground that is likely to shift.
- **NEVER** Lift the pump by the mains cable, or the float switch cable.
- **ALWAYS** use the handle, with rope or chain attached when lifting the pump.
- **ALWAYS** disconnect the pump from the electrical supply before placing it into, or removing from the water, and before any cleaning or maintenance of the pump.



ELECTRICAL CONNECTIONS

All models EXCEPT HSE301 & 361, should have their mains lead connected to a standard 230Volt (50Hz) electrical supply through an approved plug or a suitably fused isolator switch. We recommend that these pumps be fitted with a Residual Current Device (RCD).

NOTE: This is mandatory when pump is used for pumping swimming pools.

Model s HSE301 & 361 must be connected to a protected 110V supply, through a suitably approved connector. On no account must a 230V, 13amp plug be used.

NOTE: If a portable 110V transformer is used, make sure it has a rated capacity sufficient to take the load of the pump.

In the event that the pump is hard wired into the electrical system, it must be carried out in accordance with IEE regulations.

If used for draining swimming pools or ponds, the pump MUST be fitted with a Residual Current Device (RCD), with a rated residual operating current of no greater than 30mA.

WARNING: THIS APPLIANCE MUST BE EARTHED

IMPORTANT: The wires in the mains lead are coloured in accordance with the following code:

Green & Yellow	-	Earth
Blue	-	Neutral
Brown	-	Live

As the colours of the flexible cord of this appliance may not correspond with the coloured markings identifying terminals in your plug proceed as follows:

- Connect GREEN & YELLOW coloured cord to plug terminal marked with a letter "E" or Earth symbol "⏏" or coloured GREEN or GREEN & YELLOW.
- Connect BROWN cord to terminal marked with a letter "L" or coloured RED
- Connect BLUE cord to terminal marked with a letter "N" or coloured BLACK

The fuse in the plug for this appliance must be rated at **13 amps**.

If this appliance is fitted with a plug which is moulded onto the electric cable (i.e. non-rewirable) please note:

1. The plug must be thrown away if it is cut from the electric cable. There is a danger of electric shock if it is subsequently inserted into a socket outlet.
2. Never use the plug without the fuse cover fitted.
3. Replacement fuse covers can be obtained from your local dealer or most electrical outlets
4. The fuse in the plug must be replaced with one of the same rating (**13 amps**) and this replacement must be ASTA approved to BS1362.

IMPORTANT: If in doubt, consult a qualified electrician

FEATURES

The pumps are of rugged and durable construction, designed for long lasting continuous operation, and the motor is provided with a built in overload protector.

These pumps may be used for pumping water, or water containing small solids in suspension, please refer the Specifications on page 2 to determine the solid sizes that may be pumped with your pump.

The HSEC 400A is fitted with a Tungsten Carbide cutter, and is specially suited for heavily polluted waste water and waste solids, such as sewage, light slurry, factory waste etc.

Automatic Pumps, i.e. those fitted with a Float Switch, denoted by an 'A' suffix to their model number, are suitable for permanent or semi-permanent installations, eg. installations where it is necessary to maintain a water at a particular level.

As the water level rises, the switch will float, and start the pump. As the water level falls, so will the float switch, until it stops the pump.

Float switches are factory set to provide the correct ON-OFF switching mode.

It is not recommended that these pumps be used for pumping drinking water, as there is a remote possibility of water contamination due to leakage of pump lubricant, should the pump malfunction.

INSTALLATION

The pumps are completely submersible, and should be placed in a vertical position, on a solid flat surface. If this is not available, sit the pump on timber, or house bricks, but ensure they are not likely to shift.

Automatic versions should be placed in a sump which has adequate dimensions so as not to restrict the movement of the float switch.

Connect the outlet to the largest diameter hose possible, any restrictions will reduce capacity, and put additional strain on the motor.

Take all necessary precautions as described on page 4 before plugging in, and switching ON.

SUITABLE HOSE, FOR ALL PUMPS, IS AVAILABLE FROM YOUR CLARKE DEALER

TROUBLESHOOTING

PROBLEMS	POSSIBLE CAUSES
Pump does not run and hums	<ul style="list-style-type: none"> * Line circuit breaker is off, or fuse is burned or loosed. * Water level in sump has not reached turn-on level as indicated in installation drawing. * Pump cord is not making contact in receptacle. * Float is stuck. It should operate freely in basin. * If all of the above are OK, and then the motor could be operate.
Pump runs but does not deliver water.	<ul style="list-style-type: none"> * Check valve is installed backwards. Arrow on valve should point in direction of flow. * Discharge shut-off valve (if used) may be closed. * Impeller or volute openings are fully or partially clogged. Remove pump and clean. * Pump is air-locked. Start and stop several times by plugging and unplugging cord. Check for clogged vent hole in pump case. * Inlet holes in pump base are clogged. Remove pump and clean the openings. * Vertical pumping distance is too high. Reduce distance or change the discharge fittings of the pump.
Pump runs and pumps out sump, but does not stop.	<ul style="list-style-type: none"> * Float is stuck in up position. Be sure float operates freely in basin. * Defective float switch. Replace with float switch. * Defective vertical switch. Replace with vertical switch.
Pump runs but delivers only a small amount of water.	<ul style="list-style-type: none"> * Pump is air-locked. Start and stop several times by plugging and unplugging cord. Check for clogged vent hole in pump case. * Vertical pumping distance is too high. Reduce distance or change the discharge fitting of the pump. Inlet holes in pump base are clogged. Remove pump and clean the strainer and openings. * Impeller or volute openings are fully or partially clogged. Remove pump and clean. * Pump impeller is partially clogged with tar or paint, causing motor to run slow and overload. Remove pump and clean. * Pump impeller is partially clogged with tar or paint, causing motor to run slow and overload. Remove pump and clean.
Fuse blows or circuit breaker trips when pump starts.	<ul style="list-style-type: none"> * Motor stator may be defective. * Fuse size or circuit breaker may be too small. (Must be 15 amps). * Impeller or volute opening are fully or partially clogged.

MAINTENANCE

Check pump installation regularly to ensure the base inlet is clear of leaves or other debris.

Note that these pumps are fitted with automatic thermal overload protection. If the pump overheats due to an obstruction in the pump, or pumping warm water for example, it will shut off automatically. Switch the pump OFF and disconnect from the mains supply. Check for blockages and allow the motor to cool (at least 5 minutes) before attempting to re-start.

This pump should require no maintenance other than regular cleaning. If the pump starts to show signs of wear or damage, contact your CLARKE dealer for advice. Do not use the pump if there is any damage to the mains supply cable, or to the float switch or its cable.

Do not attempt to repair the pump yourself, as you may damage the waterproof seal and invalidate your guarantee. Repairs must be carried out by your CLARKE dealer, or contact the CLARKE Service Dep't, on 020 8988 7400

If using this pump to pump out a garden pond, please note that there is a small quantity of oil in the pump seal. If the pump or seal is damaged, possibly caused by running the pump dry, oil may leak out, and appear as a film on the surface of the water. Although harmless to people, the oil must be cleared to prevent any possible harm to pond life. Disconnect the pump from the electrical supply, remove it from the pond, and clear the oil, then contact your CLARKE dealer for advice.

Clarke[®]
INTERNATIONAL

PARTS LIST & DIAGRAM

HSE 120

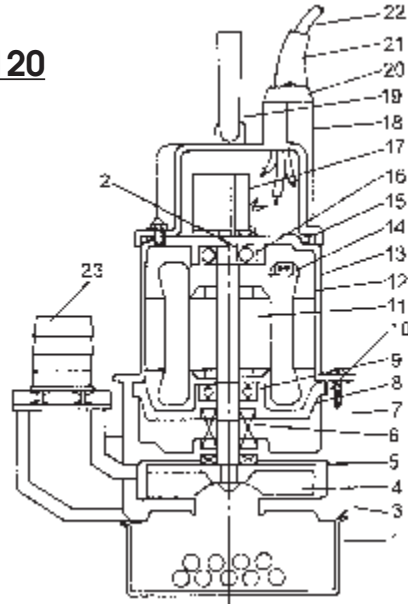

No.	Description	Part No.
1	Strainer	HG12001
2	Centrifugal Switch	HG12002
3	Pump Housing	HG12003
4	Impeller	HG12004
5	Lip Seal	HG12005
6	Mechanical Seal	HG12006
7	Oil Chamber	HG12007
8	Bottom Motor Plate	HG12008
9	Lower Bearing	HG12009
10	'O' Ring	HG12010
11	Rotor Shaft	HG12011
12	Stator	HG12012
13	Motor Case	HG12013
14	Overload Protector	HG12014
15	'O' Ring	HG12015
16	Upper Bearing	HG12016
17	Capacitor	HG12017
18	Upper Cover	HG12018
19	Handle	HG12019
20	Gland Cover	HG12020
21	Cable Gland	HG12021
22	Power Cable	HG12022
23	Discharge Outlet	HG12023

PARTS LIST & DIAGRAM

HSE 200 - 300 - 360

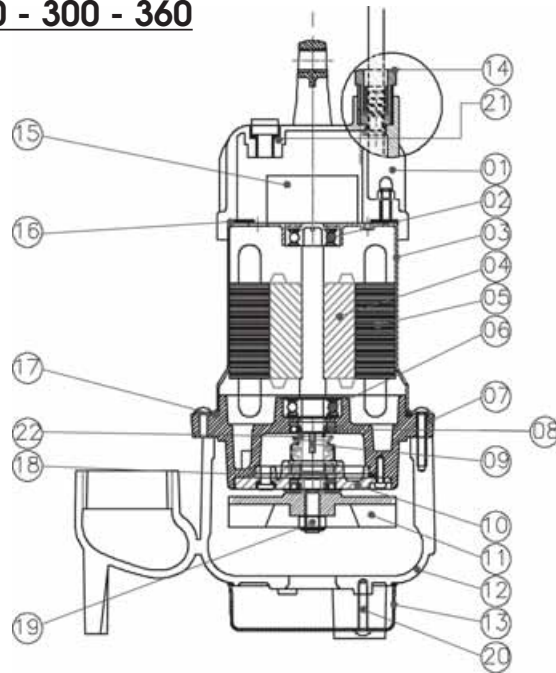

		HSE200	HSE300	HSE301	HSE360	HSE361
1	Top Cover	HG20001	HG30001	HG30101	HG36001	HG36101
2	Upper Bearing	HG20002	HG30002	HG30102	HG36002	HG36102
3	Motor Housing	HG20003	HG30003	HG30103	HG36003	HG36103
4	Shaft	HG20004	HG30004	HG30104	HG36004	HG36104
5	Stator	HG20005	HG30005	HG30105	HG36005	HG36105
6	Lower Bearing	HG20006	HG30006	HG30106	HG36006	HG36161
7	Seal Platc	HG20007	HG30007	HG30107	HG36007	HG36171
8	Oil Seal	HG20008	HG30008	HG30108	HG36008	HG36181
9	Me. Seal	HG20009	HG30009	HG30109	HG36009	HG36191
10	Seal Cover	HG20010	HG30010	HG30110	HG36010	HG36101
11	Impeller	HG20011	HG30011	HG30111	HG36011	HG36111
12	Pump Casing	HG20012	HG30012	HG30112	HG36012	HG36112
13	Strainer	HG20012	HG30013	HG30113	HG36013	HG36113
14	Power cord set	HG20014	HG30014	HG30114	HG36014	HG36114
15	Capacitor	HG20015	HG30015	HG30115	HG36015	HG36115

PARTS LIST & DIAGRAM

HSEC 400A

No.	Description	Part No.
1	Strainer	HG400A01
2	Strainer Packing	HG400A02
3	Impeller	HG400A13
4	Pump Casing	HG400A04
5	Oil Seal	HG400A05
6	Oil Cover	HG400A06
7	Oil Cover Packing	HG400A07
8	Mechanical Seal	HG400A08
9	Motor Casing Pkg	HG400A09
10	Lower Bearing	HG400A10
11	Motor Casing	HG400A11
12	Rotor Shaft	HG400A12
13	Stator Coil	HG400A13
14	Centrifugal Switch	HG400A14
15	Thermal Overload	HG400A15
16	Centrifugal Plate	HG400A16
17	Upper Bearing	HG400A17
18	Motor Casing Pkg	HG400A18
19	Inside Cover	HG400A19
20	Head Cover Pkg.	HG400A20
21	Capacitor	HG400A21
22	Cable Gland	HG400A22
23	Gland Packing	HG400A23
24	Power Cable	HG400A24
25	Handle	HG400A25
26	Outlet Discharge.	HG400A26

