



apparecchi medicali s.r.l.

EXCELL

MCDS

SERVICE MANUAL

INDEX

INSTRUMENTS REQUIRED.....	2
INTRODUCTION.....	2
CONTROL OF SUPPLY SECTION (LOW VOLTAGES).....	5
CONTROL OF SUPPLY SECTION (VARIABLE VOLTAGE).....	5
<i>Ramp signal control</i>	5
<i>Calibration of values of the variable voltage (minimum and maximum)</i>	5
<i>Thermal protection control</i>	7
CONTROL OF THE REFERENCE VOLTAGES FOR THE A/D CONVERTERS.....	7
CONTROL OF THE LOCAL OSCILLATOR AND OF THE DRIVING SIGNALS.....	7
ATTENUATION OF PULSE WIDTH (IN THE SPRAY AND FULGURATION FUNCTIONS).....	8
CALIBRATION OF "POWER READING SECTION".....	9
<i>Analog Multiplier, Calibration of the offset of the "X" inputs</i>	9
<i>Analog Multiplier, Calibration of the offset of the "Y" inputs</i>	9
<i>PWRFM signal, Calibration of the output offset</i>	10
<i>IRFMB signal, Calibration of the output offset</i>	10
CONTROL OF SIGNALS FOR THE CORRECT OUTPUT POWER.....	10
<i>Output signal, control of the average modulation value</i>	10
<i>Control of the signal proportional to the monopolar output power</i>	11
<i>Control of the signal proportional to the monopolar and bipolar output current</i>	11
<i>Control of monopolar output power</i>	11
<i>Calibration of the limitation of the maximum output current (only models 400 and 250)</i>	11
<i>Calibration of the maximum output peak voltage</i>	11
<i>Calibration of the maximum monopolar output current (function per function)</i>	12
<i>Control of bipolar output power</i>	12
<i>Calibration of the maximum bipolar output current (function per function)</i>	13
<i>Re-enabling of the standard EPROM</i>	13
<i>Control of the neutral plate alarm circuit (REM type)</i>	13
CONTROL OF HF LEAKAGE CURRENT.....	14
WIRING DIAGRAMS, ARRANGEMENT OF COMPONENTS AND LIST OF MATERIALS.....	a
<i>Block diagram</i>	a
<i>801301 – Power Supply Board</i>	b
<i>801302 – R.F. Main Board</i>	c
<i>801303 – Microcontroller Board</i>	d
<i>801304 – R.F. Driver Board</i>	e
<i>801305 – R.F. Power Board</i>	f
<i>801306 – Power Reader Board (1)</i>	g
<i>801307 – Power Reader Board (2)</i>	h
<i>801308 – Double Handle & Neutral Plate Control Board</i>	i
<i>801309 – Double Switch Handle Board</i>	j
<i>801310 – Panel Board (400mcDs – 250mcDs)</i>	k
<i>801326 – Panel Board (350mcDs – 200mcDs)</i>	l
<i>UNITS (INTERNAL DETAILS – ELECTRONIC BOARDS, SOCKETS, SWITCHES, ETC.)</i>	m
<i>WIRINGS CONNECTIONS</i>	n

This handbook has been written to provide skilled personnel with a method required to set and check the characteristics of the device and to assist the user, if necessary, in the identification of the most frequently encountered faults.

INSTRUMENTS REQUIRED

<i>DESCRIPTION</i>	<i>TECHNICAL CHARACTERISTICS</i>	<i>EXAMPLE</i>
Oscilloscope	<i>Dual channel - Band width: > 40 MHz</i>	Tektronix mod. TDS210
Digital Multimeter	<i>TRMS reading - Precision: 3%</i>	Metrix mod. MX54
Current probe	<i>Band width: 200 Hz÷50 MHz</i>	Tektronix mod. P6021
Tester for H.F. leakage and output power control with antinductive loads from 50 to 1500 ohms	<i>Precision: 5%</i>	Automatic tester as Dynatech DNY 454A Or Single loads and thermocouple instruments RMS with scale 0-250 or 500 mA and 0-1,5 A
Set of materials needed for control and calibration	<i>Extended wirings, EPROM memory "calibration and control" Etc.</i>	
Automatic tester for low frequency leakage control (1)	<i>Responding to IEC 601-1 International standards (able to perform tests according to)</i>	Different models of Company METRON, Company DYNATECH; Etc.

INTRODUCTION

The electrosurgical unit EXCELL MCDS is a HF generator, completely controlled by two microcontrollers, with, as power section, a damped oscillator (working at a frequency of 475 kHz), able to deliver by output transformers (for monopolar or bipolar section) a maximum power of 400 Watt for the monopolar performances and of 99 Watt for the bipolar performances.

The unit, provided of every possible device needed to select, control and activate different performances and functions, consists of 4 main sections:

- Power supply section;
- H.F. power section;
- Microcontroller section;
- Output Power reading section.

The power supply section supplies all the continuous voltages required in the device.

These voltages are:

- ◆ +5V (continuous) for the programmable system;
- ◆ +15 –15 V (continuous) for driving circuits;
- ◆ from 0 to 150 V (adjustable) for power supply of H.F. section.

The first three voltages (+5 V and +15 – 15 V) are obtained by means of three linear voltage stabilisers.

The adjustable voltage is obtained using a switching section (configuration FORWARD type), powered by the mains transformer. The "heart" of this power section consists of a PWM 3525 circuit (working at a frequency of 115 kHz) driving, by means of a SIRIO transformer (three windings with 1:1:1 transformation ratio), alternately two MOS-FETs (best choice IRF 740).

The enabling signals and the settings of the power supply of H.F. section, type PWM, are provided directly by the *Microcontroller board*.

The microcontroller section controls the correct running of the whole device performing a continuous autodiagnosis in order to detect any anomalies or damages in the unit or in the accessories connected to it. For this purpose a main self-test phase runs both every time the unit is turned on and cyclically about every 45 minutes of working. If the system detects a fault the device is stopped until the cause is eliminated and the display on the front panel shows a error code (see the following table) that provides the operator with a specific information about the type of fault detected. So some useful information is indirectly achieved

(1) The test of LF leakage current can be performed also by a circuit corresponding to that indicated in the Par. 19.4 of IEC 601-1; using this circuit it is necessary even a rotary transformer (1,5 kV) to adjust the mains supply

concerning the part that could be damaged and that needs adjusting in order to restore the complete efficiency of the unit.

ALARM CODE	PROBLEM
blinking displays	Device continuously activated for more than 30 seconds
ErrNP	Neutral plate connection problem
ErrACT	Activation error (two activation switches pressed at the same time or wrong activation compared to the functions selected on the control panel)
ErrPED	Pedal switch pressed when the device was turned on
ErrHND	Hand switch pressed when the device was turned on
Err21	Push button on control panel pressed when the device was turned on
Err1	General system error
ErrIIC	Communication problems between the peripheral units
ErrHt1	Over heating in the RF section
ErrHt2	Over heating in the power supply section
ErrUP2	"Slave" microcontroller trouble
ErrAL5	Fault of the +5V power supply of both microcontroller
ErrNPC	Fault of neutral plate alarm circuit (inside the unit)
ErrAD2	Conversion problems in the digital converter of the "slave" microcontroller
Err9	Fault of power supply control in the monopolar RF section
ErrI0	Fault of power supply control in the bipolar RF section
ErrI1	Fault of RF modulation signal control
ErrI2	Fault of reading signal of the monopolar power control
ErrI3	Fault of reading signal of the monopolar power in the "spray" mode control
ErrI4	Fault of reading signal of the bipolar power control
ErrI5	Problems about internal RAM of both microcontrollers
ErrI6	Fault of EPROM CRC control
ErrI7	Fault of EEPROM data integrity control
Err20	Fault of <i>master</i> watchdog timer
Err23	(available)
Err25	System variables complementation error
Err27	Problems in reading the effective output current
Err28	Output peak voltage reading problems
Err30	Problems in the voltage reference of the neutral plate alarm circuit

The H.F. power section consists of an oscillating circuit composed by four MOS-FETS (type IRFPE50) connected in parallel (in order to obtain the maximum output power), each of which is driven separately by a MOS-FET driver (type MAX 4420). By means of this oscillating circuit the variable continuous voltage coming from the power unit section is "transformed" into a sinusoidal wave form with frequency of 475 kHz and the power is then transferred (from the L7 inductor) to the output transformers (monopolar and bipolar) on the *Mother board*. An additional MOS-FET on the same board cuts off the pulses when the unit is activated with open circuit. The driving signals for this section come from the *R.F. driver board*, on which a UC 3825 PWM driver circuit can pick-up (depending on the function settings on the front panel) one of the three ramp signals used to provide a different pulse width according to the wave form selected (type of performance for example cut, coag. ...). This ramp signal, supplied by the square wave of the local oscillator at 950 kHz, is sent to the *Microcontroller board* circuits U5-U6 (74HCT4040 and 16V8 PLD respectively), and it is set using the R13, R14 and R15 pots in order to obtain the pulse width desired. On the microcontroller board there is also the acoustic alarm section.

The device consists even of other secondary sections:

- a) The *Double handle & neutral plate control board* contains: the hand activation circuit and the neutral plate alarm circuit, both with insulation between patient and intermediate circuits granted using transformers (made with ferrite toroid cores with two insulated windings) capable of withstanding a test voltage higher than 3000 VAC.

The first one works as follows:

When a push button of the hand switch (connected to the secondary winding of these transformers) is pressed produces a variation of magnetic flow between the two windings (primary and secondary) and a reduction of the amplitude of the signal on the primary winding. Therefore this reduction is detected by the *Microcontroller board* as the activation of one of the hand switches and consequently it is enable the H.F. power flowing through the selected output

The second one is realised according to the same principle described above and it is able to control not only the correct connection of neutral plate (using every kind of neutral plate) but even the contact neutral plate/tissues (only using split REM neutral plates) and works as follows:

A oscillator composed by U1A 40106)-R1-R61-C1, supplies a current at frequency of 60 kHz \pm 5 kHz that drives the T1 transformer. Once the maximum amplitude of the signal is obtained using the R1 pot, depending on the load connected to the neutral plate, a signal is sent to the window comparator composed by U2A and U3A op amps (LM324). This comparator provides the microcontroller with the "information" needed to distinguish the three different levels of contact between neutral plate and tissues as described below.

Ideal contact: neutral plate/tissues resistance up to about 75 Ω (plate alarm LED off and complete use of the device)

Poor contact: neutral plate/tissues resistance from about 80 to 150 Ω (plate alarm LED flashing and maximum output power reduced to max 200W)

Insufficient contact: neutral plate/tissues resistance over than 150 Ω (plate alarm LED always on, acoustic alarm on, "Err PN" on display and output power stopped).

When the unit is used with standard neutral plates (no split REM) the system works only in situation of ideal contact (neutral plate cable not broken, well connected to the unit and to the neutral plate) or insufficient contact (neutral plate cable broken or not connected to the unit or to the neutral plate).

Power reader board (1) and (2): the circuits on these boards are used for two different purposes:

- 1) General control of all output powers
- 2) Dynamic optimisation and stabilisation of the output power (monopolar and bipolar), by means of a feed back between unit and tissues (electrical load impedances), independently from the variations of the load impedance.
- 3) Automatic start/stop of bipolar coagulation (function MPA) according to the variation of load impedance (tissues).

To obtain these results the circuit supplies the microcontrollers with some signals proportional to the output power and, according to these signals, the microcontroller "adjusts" the working parameters to obtain the maximum possible stabilisation of the output power.

The heart of this section is a current and voltage reading transformer that picks up the signals from the output sending them to some analog multipliers (HA325569 and AD633).

When the automatic bipolar coagulation (MPA) is selected this section evaluates also the impedance (tissues) connected to the bipolar forceps to obtain the correct start/stop of the output power.

If the impedance is about 30 Ω , the circuit stops the automatic start to avoid a not desired activation

If the impedance is about between 30 and 850 Ω there is the automatic start.

If the impedance is higher than 850 Ω the circuit stops automatically the output power or doesn't allow the automatic start.

To avoid instantaneous starting as soon as the forceps touch the tissue, it is possible to adjust the automatic starting delay (from 1 up to 6 seconds) using the rotary pot on the back of the unit.

- a) *Double Switch handle board:* this board changes (using two relays, which are connected in series for each monopolar output) the path of H.F. power towards the output selected and activated by the user.

On the same board other two relays are used to check the integrity of the neutral plate circuit and the bipolar output path during the main self-test routine.

The presence of the self-test system may prevent the repair of the unit as, when a fault is pointed out, stops the working and many signals required for the communication among the different sections are blocked.

It is therefore necessary to *by-pass* the self-test routine if the device has to be technically inspected. For this purpose has been prepared an appropriate EPROM memory (Alsa code 713958) *TO BE USED ONLY AND EXCLUSIVELY DURING THE CALIBRATION PHASE OR FOR TECHNICAL ASSISTANCE.*

In this memory, useful even for calibration and control procedure, the self-test phase is reduced as possible

The “**calibration and control EPROM**” must be used as follows:

- 1) Replace, on the *Microcontroller board* the standard EPROM with the “calibration and control EPROM” (paying attention to insert it correctly)
- 2) Turn on the unit and, to start the “control or calibration procedure”, use on the front panel the push button M selecting memory II (M_II) and (with push buttons up-down of monopolar CUT or COAGULATION) the type of control or calibration. The code correspondent to the desired test is shown on the display - monopolar CUT.

For every test or for every series of tests is below detailed (on the correspondent paragraph) the selection necessary to start the specific procedure (specific tables of setting)

- 3) Once performed the starting selection, using push button M, select memory I (M_I) and perform calibrations or controls (according to the specific instructions below detailed for every test)

General Warnings about the instructions to perform the controls:

- a) To activate the unit you have to use the pedal switch needed for the function selected (for example: monopolar PC with cut pedal of monopolar double pedal)
- b) To select a performance you have to use the correspondent push button S (for example: monopolar pure cut with push button S “function PC” of cut section area “mono”, bipolar pure cut with push button S “function PC” of cut section area “bip”)
- c) The word “code” is used to identify the value or the code set on the displays
- d) When one has to use the current probe to check a wave form or a current on the output circuit connected to a load, the probe must be connected in series to the load
- e) To automatically save the calibrations or settings performed it is necessary to switch the unit off. It is possible to save every single calibration at a time or all together at the end of the procedure

CONTROL OF SUPPLY SECTION (LOW VOLTAGES)

Turn the device on and check on the *Power supply board*, using a multimeter, if the stabilised +15V (TP¹ “A”), -15V (TP “B”) and +5V (TP “C”) voltages are present and, if necessary, adjust the R105 pot on the same board to obtain a voltage of +5V (+0.1/-0V).

CONTROL OF SUPPLY SECTION (VARIABLE VOLTAGE)

RAMP SIGNAL CONTROL

Connect the probe of the oscilloscope to TP “D” (pin 5 of UC 3525) on the *Power supply board*, turn the device on and check if the wave form corresponds to the following:

(TP “D”)

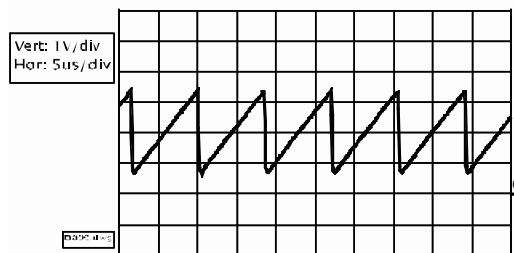

CALIBRATION OF VALUES OF THE VARIABLE VOLTAGE (MINIMUM AND MAXIMUM)

To start the following tests perform the selection detailed in the table below

Setting Memory	Monopolar Cut Display	Monopolar Coag. Display
M II	00	-

- 1) Select M_I.
- 2) Connect the multimeter to TP “E” (VREG) on *Power supply board*, set function “monopolar PC” and code “FF”, activate the device and calibrate the R6 pot on the same board to obtain a continuous voltage of 150V (± 2 V) on VREG.
- 3) Connect the probe of the oscilloscope to TP “F” (R22) and the multimeter to TP “E” (VREG), set function “monopolar PC” and code “FE”, activate the device and calibrate the R14 pot to obtain a continuous voltage of 3V ($\pm 0,1$) on VREG and the following wave form on TP “F”:

¹ TP “A”: Test Point “A”

(TP "F")

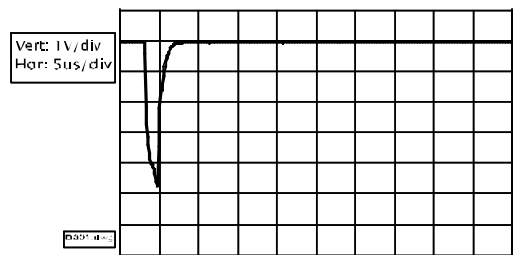

The settings of the minimum and maximum voltages interact with each other. This check must be repeated at least three times to check the correctness of the values to be obtained.

4) Activating again the unit with code "AA": a voltage of 100V ($\pm 2V$) should be obtained together with the following wave form on TP "F":

(TP "F")

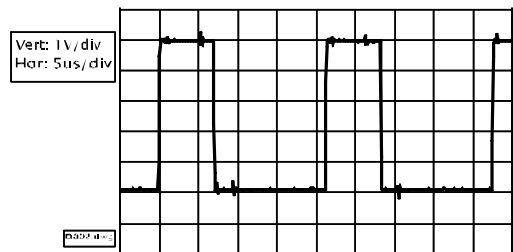

5) Set function "bipolar PC" and code "FF", activate the device and calibrate the R4 pot to obtain a continuous voltage of 150V ($\pm 2V$) on VREG.

6) Activate again the device with code "FE" and calibrate the R13 pot to obtain a continuous voltage of 3V ($\pm 0,1V$) on VREG and the following wave form on TP "F":

(TP "F")

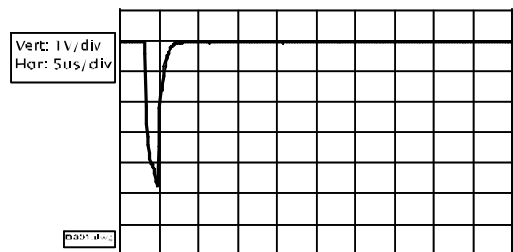

The settings of the minimum and maximum voltages interact with each other. This check must be repeated at least three times to check the correctness of the values to be obtained.

7) Activate again the unit with code "AA": a voltage of 100V ($\pm 2V$) should be obtained together with the following wave form on TP "F":

(TP "F")

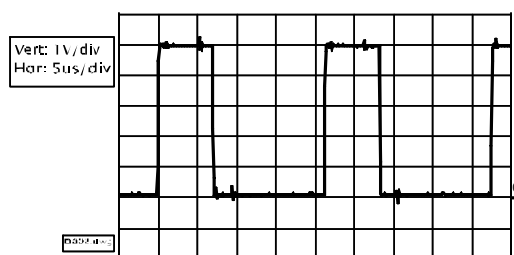

THERMAL PROTECTION CONTROL

Turn the device on shorting the NTC R79 pins on the *Power supply board*. The display should show the alarm code "Err Ht2" with acoustic alarm signal.

Turn the device off and on again to restore normal running conditions.

CONTROL OF THE REFERENCE VOLTAGES FOR THE A/D CONVERTERS

Many of the controls and settings automatically carried out by the unit depend on the calibration of these voltages. Therefore these values must be particularly precise.

1) On the *Microcontroller board*, connect the multimeter to TP "G" (R64), calibrate the R70 pot to obtain a voltage of 4.81V (± 0.01 V); connect the multimeter to TP "H" (R66) and calibrate the R68 pot to obtain a voltage of 110mV (± 0.002 V).

2) On the *Panel board*, connect the multimeter to TP "I" (LM431) and calibrate the R24 pot to obtain a voltage of 4.81V (± 0.01 V).

CONTROL OF THE LOCAL OSCILLATOR AND OF THE DRIVING SIGNALS

To start the following tests perform the selection detailed on the table below

Setting Memory	Monopolar Cut Display	Monopolar Coag. Display
M II	02	-

1) Select M I

2) Connect the oscilloscope to TP "J" (*R.F. driver board*)

3) Turn the unit on but not activate it and check the signal: it should correspond to the following wave form (f= 940 kHz \pm 5kHz): Turn the unit on but not activate it and

(TP "J")

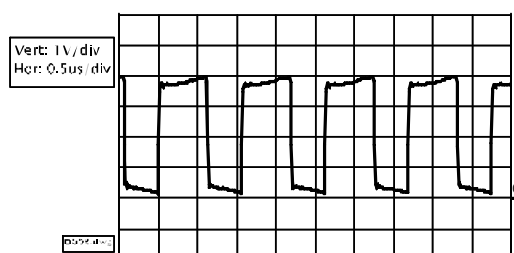

The DRVRF2 signal drives the MOS-FETS on the *R.F. power board*.

2) Disconnect J5 connector of the *Power Supply Board*, in order to avoid any damages (if the control circuits for the driving signals of the power section should be faulty).

3) Connect the oscilloscope to TP "K" (D8) of the *R.F. driver board*, set function monopolar PC, activate the device and check DRVRF2 signal. It should be as below specified, with a pulse width of 440 ns (± 20 ns) (if necessary calibrate the R13 pot on the same board):

(TP "K")



4) Activate again the unit, setting function "monopolar SPR". You should obtain the following wave form (pulse width equal to 1 µs (±10 ns), if necessary calibrate the R15 pot:

(TP "K")

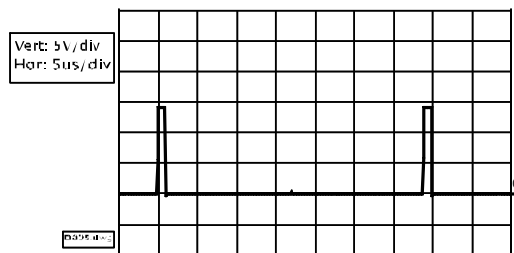

5) Activate again the unit setting on mod. 400 and 250 function "bipolar PC", or on mod. 350 and 200 function "bipolar MP". You should obtain the following wave form (duration equal to 315 ns (±15ns), if necessary calibrate the R14 pot):

(TP "K")

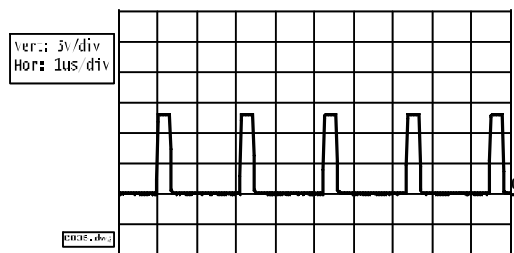

ATTENUATION OF PULSE WIDTH (IN THE SPRAY AND FULGURATION FUNCTIONS)

To start the following tests perform the selection detailed in the table below

Setting Memory	Monopolar Cut Display	Monopolar Coag. Display
M II	06	-



(To perform this test it is necessary a set of cables (wiring for assistance) needed to connect the R.F. power board placed out of the device so that can be reached easier for any need of calibration).

1) Disconnect both the standard wiring and the J5 connector on the *Power Supply Board* and position the *R.F. power board* out of the unit. Connect it using the "wiring for assistance" (**J5 must be not connected**).

Connect the probe of channel no. 1 of the oscilloscope to TP "L" (R12) on *R.F. power board* and the probe of channel no. 2 to TP "M" (R37) of the same board.

2) Select M I

3) Set the function "monopolar SPR", activate the device and check the wave form. It should be as follows:

(TP "L"; TP "M")

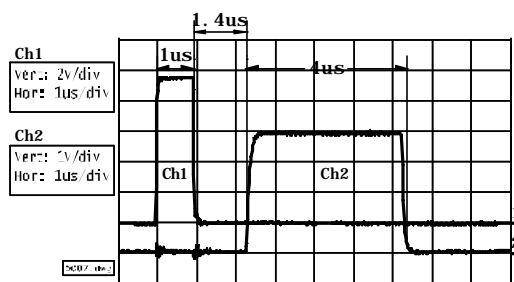

The width of the "Ch2" pulse must be 4 μ s and can be calibrated using the R35 pot on the *R.F. power board*. The delay between the two pulses must be equal to 1.4 μ s and can be calibrated using the R31 pot of the same board.

Once this board is calibrated, disconnect the "wiring for assistance" and re-position the board inside the device re-connecting both the standard wiring and the J5 connector.

CALIBRATION OF "POWER READING SECTION"

To start the following tests perform the selection detailed on the table below

Setting Memory	Monopolar Cut Display	Monopolar Coag. Display
M II	02	-

The correct running of the whole device depends on the calibration of this section, as the microcontroller section is mainly based on signals coming from this section to carry out many of the controls and adjustments needed to grant the efficiency of the unit. It is therefore necessary to perform this calibration with maximum care.



Before continuing the calibration, turn the R4 pot on the R.F. main board completely anti-clockwise in order to release the output current limitation. This current must be limited again before performing the test "calibration of the limitation of the maximum output current" in order to avoid damages connecting the output to a load lower than 50 Ω .

1) Connect the monopolar output to a 400 Ω load and connect the current probe to check the output wave form and current. Connect the voltage probe to TP "N" on the *Power reader board* (2, set function "monopolar PC" and code "56").

2) Activating the unit check the output current, should be equal to 400 mA (the starting code "56" is only a reference; if necessary adjust until 400 mA are obtained).

Using the R4 pot of the *Power reader board* (1), calibrate the wave form read by the voltage probe so that it is without distortions and as equal as possible to the current wave form.

(I out; TP "N")

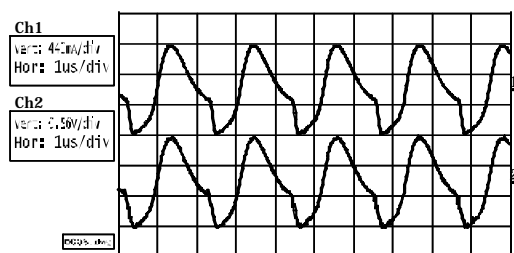

ANALOG MULTIPLIER, CALIBRATION OF THE OFFSET OF THE "X" INPUTS

1) Connect the R4-R5 resistors on the *Power reader board* (2) to ground on the opposite side of U2 and connect the probe of the oscilloscope to TP "O" on the same board.

2) Set function "monopolar PC" and code "10", activate the device and adjust the R3 pot on that board to obtain the minimum amplitude of signal.

3) Disconnect from ground the R4-R5 resistors.

ANALOG MULTIPLIER, CALIBRATION OF THE OFFSET OF THE "Y" INPUTS

Repeat for the R7-R8 resistors (adjusting pot R6) on the same board the procedure above detailed about R4-R5 resistors.

PWRFM SIGNAL, CALIBRATION OF THE OUTPUT OFFSET

- 1) Connect the oscilloscope to TP "P" on *Power reader board (2)*. Set function "monopolar PC" and code 10. Without activating the device, calibrate the R31 pot on the same board to obtain a voltage of 124 mV .
- 2) Connect then the probe to TP "Q" (same setting) and, without activating the device, calibrate the R43 pot to obtain a voltage of 100 mV.

IRFMB SIGNAL, CALIBRATION OF THE OUTPUT OFFSET

- 1) Connect the oscilloscope to TP "P" on *Power reader board (2)*. Set function "monopolar PC" and code 10. Without activating the device, calibrate the R75 pot on the same board to obtain a voltage of 133 mV .
- 2) Connect the oscilloscope to TP "S" (same setting) and, without activating the device, calibrate the R81 pot to obtain a voltage of 100mV.

Once all these settings have been completed, check the output offsets again with the oscilloscope connected to TP "N" on *Power reader board* setting (function "monopolar PC" and codes as detailed in the following reference table)

Reference table: Use reference values (tol $\pm 5\%$) if the power reading section needs to be adjusted. The values for the various test points depend on the H.F. output current specified.

Settino value	I OUT (mA)	TP "N"	TP "N ₁ "	TP "N ₂ "	TP "P"	TP "Q"	TP "R"	TP "S"
14	100	0.136	0.182	0.050	0.664	0.564	1.220	0.925
2A	200	0.269	0.358	0.174	1.290	1.090	1.700	1.290
3E	300	0.400	0.535	0.382	1.930	1.630	2.080	1.580
53	400	0.541	0.718	0.685	2.590	2.190	2.410	1.820
67	500	0.670	0.890	1.050	3.240	2.720	2.690	2.040
76	600	0.803	1.018	1.390	3.910	3.260	2.950	2.230
90	700	0.940	1.248	2.060	4.540	3.820	3.190	2.410
A5	800	1.070	1.428	2.700	5.210	4.370	3.410	2.580
BA	900	1.200	1.620	3.400	5.86	4.910	3.620	2.750
D2	1000	1.350	1.793	4.190	6.540	5.400	3.810	2.890

To modify the value on TP "N" on *Power reader board (2)*, set function "monopolar PC", code as above detailed, activate the unit and adjust the R5 pot of the *Power reader board (1)*. Doing this calibration also the value on TP "N₂" on *Power reader board (2)* should be that indicated in the reference table.

The value of TP "N₁" on the same board can be calibrated, if necessary, adjusting the R6 pot on the *Power reader board (2)*.

When you have controlled the voltage on TP "N₁" of *Power reader board (2)*, check the corresponding value on TP "R" of the same board and, if necessary, calibrate R75 on the *Power reader board (2)* to obtain on TP "S" of the same board the values of the reference table.

The value on TP "Q" of *Power reader board (2)* can be calibrated, if necessary, adjusting the R43 pot on the *Power reader board (2)*.

Additional check:

- 1) Connect the monopolar output to a load of 400 ohm
- 2) Select function "monopolar PC"
- 3) Activate the unit and check the values according to the following table (tol $\pm 10\%$). For every code selected is specified the output current, the voltage PWRFM - pin 1 of J3 connector on *Power reader board (2)*, the voltage IRFMB - pin 3 of the same connector.

Display	Iout (mA)	PWRFM (V)	IRFMB (V)
A9	786.33	4.30	2.57
93	689.67	3.78	2.46
6A	499.67	2.71	2.06
54	395.00	2.15	1.83
3F	297.00	1.61	1.59
13	94.90	0.53	0.89

CONTROL OF SIGNALS FOR THE CORRECT OUTPUT POWER

OUTPUT SIGNAL, CONTROL OF THE AVERAGE MODULATION VALUE

To start the test perform the selection detailed on the table below

Setting Memory	Monopolar Cut Display	Monopolar Coag. Display
M II	00	03

Before checking the real output power of the unit, check the setting of the *MODMEN* parameter as follows:

- 1) Connect the monopolar output to a non-inductive load of 400 Ω .
- 2) Select M_I.
- 3) Set function "monopolar PC" and activate the device, the monopolar cut display should show a value of **116** (± 1 digit). If necessary, with the device still activated, calibrate the R34 pot on the *Microcontroller board*.

CONTROL OF THE SIGNAL PROPORTIONAL TO THE MONOPOLAR OUTPUT POWER

To do this tests perform the selection detailed in the following table:

Setting Memory	Monopolar Cut Display	Monopolar Coag. Display
M II	00	02

Selecting M_I and activating the device the monopolar cut display should show a value of the signal proportional to the output power.

- 1) Select the function "monopolar PC", code "AD" and activate the device. The display should show a value of **210** (± 3 digits). If necessary, activating the unit, adjust the R34 pot of the *Power Reader board* (2)
- 2) Select the same function but with code "56" and activate the device. The value on the display should be **102** (± 3 digits).

CONTROL OF THE SIGNAL PROPORTIONAL TO THE MONOPOLAR AND BIPOLAR OUTPUT CURRENT

To start this test perform the selection detailed in the table below:

Setting Memory	Monopolar Cut Display	Monopolar Coag. Display
M II	02	01

Selecting M_I and activating the device the monopolar cut display should show a value of the signal proportional to the output current (monopolar and bipolar).

- 1) Select M_I
- 2) Set function "monopolar PC" h code "AD" and activate the device. The display should show a value of **122** (± 3 digits). If necessary, activating the unit, adjust the R81 pot of the *Power Reader board* (2)
- 2) Select the same function but with code "56" and activate the device. The value on the display should be **84** (± 3 digits).

CONTROL OF MONOPOLAR OUTPUT POWER

- 1) Connect the monopolar output to a load of 400 Ω .
- 2) Set function "monopolar PC", code "AD" and activate the device. The output current should be equal to 800 mA ($\pm 10\%$). Setting the power level of "monopolar PC" at "56", the output current should be equal to 400 mA ($\pm 10\%$). Check even the wave form of the output current, should be sinusoidal, as shown below:

(I out)

(I out)

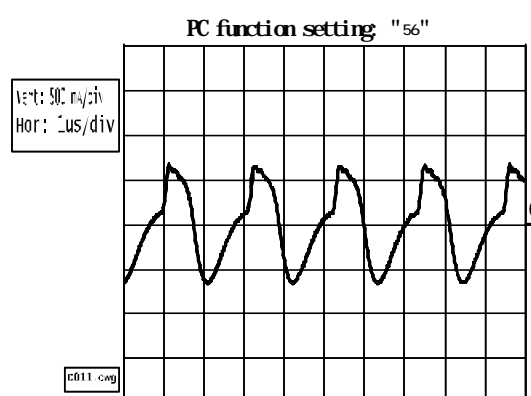
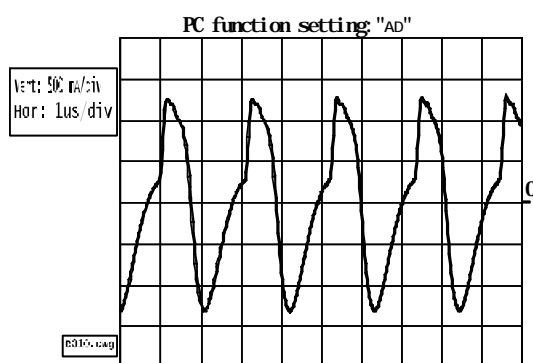

CALIBRATION OF THE LIMITATION OF THE MAXIMUM OUTPUT CURRENT (ONLY MODELS 400 AND 250)

- 1) Connect the bipolar output to a load of 50 Ω .
- 2) Set function "bipolar PC" and the maximum power that may be selected. Activate the device and calibrate the R4 trimmer on the *R.F. Main Board* adjusting the output current to 1 A ($\pm 10\%$).

CALIBRATION OF THE MAXIMUM OUTPUT PEAK VOLTAGE

To start this test perform the selection as detailed on the table below

Setting Memory	Monopolar Cut Display	Monopolar Coag. Display
M II	03	04

The maximum output voltage peak is one of the factors that affect the HF leakage current. The signal proportional to this voltage peak is *VOUTPK*.

1) Select M_I

2) Set "monopolar PC", code "A0". Activating the device the monopolar cut display should show a value of **134** (± 2 digits). If necessary adjust the R9 trimmer on the *R.F. Main Board*. Check again the *VOUTPK* value with setting code "50" (the corresponding value should be **060**).

CALIBRATION OF THE MAXIMUM MONOPOLAR OUTPUT CURRENT (FUNCTION PER FUNCTION)

To start this test perform the selection as detailed on the table below

Setting Memory	Monopolar Cut Display	Monopolar Coag. Display
M II	07	-

This calibration is needed to fix the maximum output current for each function. The value established during the procedure is automatically stored in the EEPROM containing the values of calibration (this EEPROM is on the *Panel board*).

Perform this calibration as follows:

1) Connect the monopolar output to an antinductive load of 100 Ω

2) Select M_I

3) Step by step select all the available functions starting from "monopolar PC" and, for each function, activate the unit checking the output current (should be as detailed on the following *table 1* for each function).

If the value is different, activating the unit (pressing the pedal switch), adjust the output current by the up-down push buttons used on the front panel to set the current for each function.

This calibration is possible ONLY pushing the pedal switch corresponding to the function selected otherwise it is impossible.



monopolar function		Iout (A)
Pure Cut (PC)		1.4
Blend I (BC I)		1.3
Blend II (BC II)		1.3
Blend III (BC III)		1.2
monopolar function		Iout (A)
PinPoint Contact Soft (PCS)		1.3
Fulguration (F)		1.2
Spray (SPR)		1.2
Auto (A)		1.3

Table 1 – Values detected on load of 100 Ω

CONTROL OF BIPOLAR OUTPUT POWER

To start this test perform the selection as detailed on the table below

Setting Memory	Monopolar Cut Display	Monopolar Coag. Display
M II	02	06

This setting is used to check the *PWRFB* parameter.

1) Connect the bipolar output to an antinductive load of 400 Ω

2) Select M_I

3) Set function "bipolar BC" and code "E6". Activating the unit, the monopolar coag. display should show a value of **254** (± 2 digits). If necessary, calibrate the R45 pot on the *Microcontroller board*.

4) Activate again the unit setting code "89", a value of **150** (± 2 digits) should appear on the display.

5) Activate again the unit with the same setting and check the level of the output current.

It should be: 500 mA ($\pm 10\%$) when the display shows the value **254** and 300 mA ($\pm 10\%$) when the display shows the value **150**. The waveforms relative to the two settings are shown below:

(I out)

(I out)

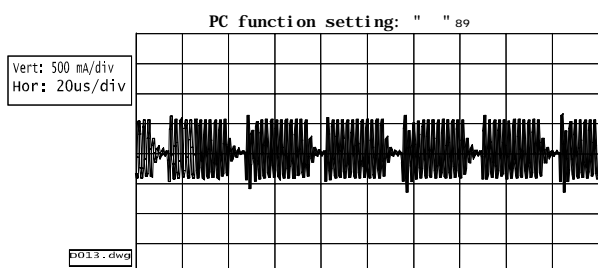
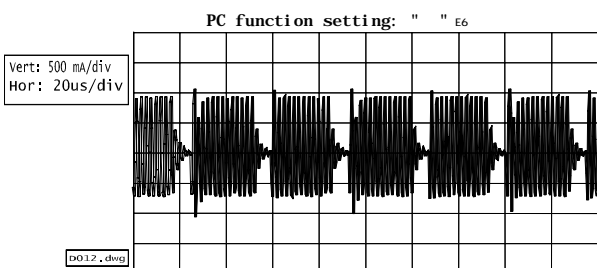

The models 350 and 200 are without the bipolar cut section. Perform the test as follows:

- 1) Connect the bipolar output as above specified (point 1), but using a load of 100 Ω.
- 2) Set function "bipolar MP" with code "A8". Activating the unit the monopolar coag. display should show a value of **165** (± 2 digits) and the output current should be 700 mA (±10%).
- 3) Activate again the unit setting code "48". The monopolar coag. display should show a value of **70** (± 2 digits) and the output current should be 300 mA (±10%). The wave forms relative to the two settings are shown below:

(I out)

(I out)

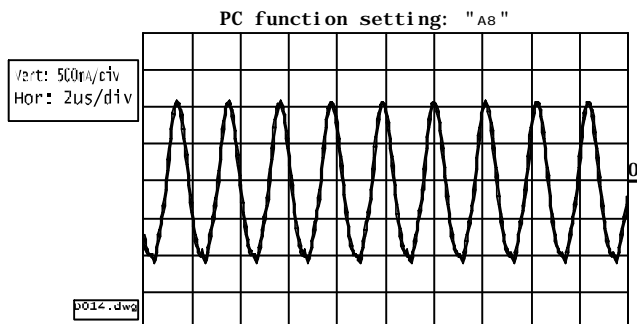

device setting: "A8"

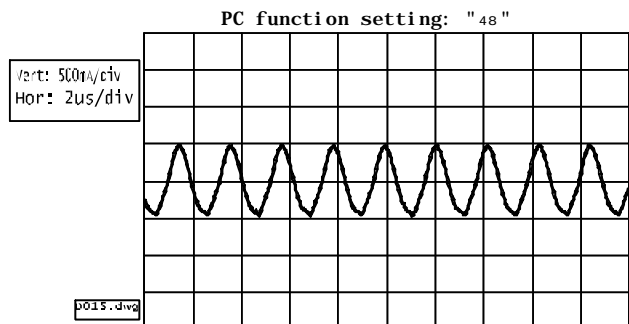

device setting: "48"

CALIBRATION OF THE MAXIMUM BIPOLAR OUTPUT CURRENT (FUNCTION PER FUNCTION)

To start this test perform the selection as detailed on the table below

Setting Memory	Monopolar Cut Display	Monopolar Coag. Display
M II	04	-

This calibration is identical to the correspondent one about monopolar functions, and so follow the same instructions.

The only difference is:

- 1) The bipolar output must be connected to an antinductive load of 50 ohm
- 2) The procedure starts from function "bipolar PC" for models 400 and 250 and from function "bipolar MP" for models 350 and 200
- 3) The output current of coagulation MPA is equal to that of coagulation MP
- 4) For values of different functions see the table below

bipolar function	I out (A)
Pure Cut (PC)	1.0
Blend (BC)	1.0
Micro Precise (MP)	0.9
Micro Prec. Auto (MPA)	0.9
Standard Macro (SM)	1.0

Table 2 – Values detected on load of 50 W

Once performed all calibrations switch off the unit and switch it on again (so you save all calibrations and settings)

RE-ENABLING OF THE STANDARD EPROM

Once the maximum bipolar output currents have been calibrated and the unit is turned off, replace the "calibration and control EPROM" with the standard EPROM, then go on as follows:

- 1) Turn the device on and wait for the end of the self-test phase (the unit is in standby mode and it is possible to modify all settings but it is impossible to activate it. The displays may show some strange characters without meaning.
- 2) To reset the unit and eliminate the problem simply press one of the two up-down power push buttons of the section showing the abnormal condition. **IF NECESSARY REPEAT THE SAME RESET FOR EACH AVAILABLE FUNCTION.**

CONTROL OF THE NEUTRAL PLATE ALARM CIRCUIT (REM TYPE)

Perform the control as follows:

- 1) Connect the probe of the oscilloscope to TP "T" on the *Double Handle & Neutral Plate Control Board* (Alsa code 801308).

2) Turn the unit on and, at the end of the self-test phase, check the presence of the following wave form:
(TP "T")

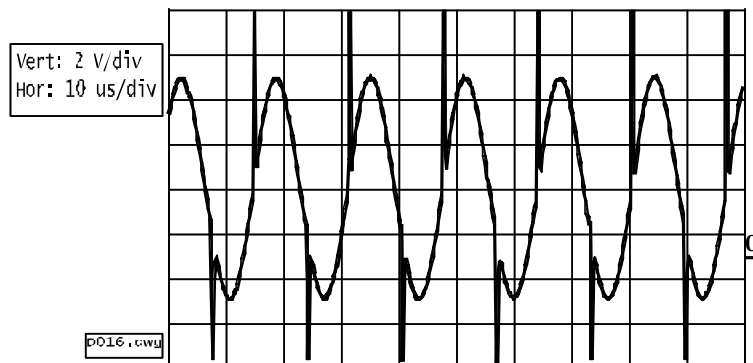

If the amplitude of signal is different, calibrate the R1 pot on the same board to obtain the maximum amplitude.

3) Check even if there is a continuous voltage equal to +5.25 V (± 0.05 V) on the TP "U". If necessary calibrate the R4 pot on the same board.

Once this calibration has been completed, the functioning range must be as follows:

- With a resistance from 0 to 150 Ω (± 30 Ω) the circuit doesn't intervene, and the unit works regularly (no alarm signals or power limitation)
- With a resistance from 150 to 250 Ω (± 30 Ω) the circuit starts intervening. The unit works with the output power automatically limited (max 200 watt) and the red alarm signal on the front panel flashes
- With a resistance over 250 Ω (± 30 Ω): the circuit works completely. The output power is completely stopped, and you have all alarm signals (the intermittent acoustic alarm, the red alarm on the front panel continuously lit up, the code "Err nP")

The system can be checked using a linear 0-300/500 Ω potentiometer.

CONTROL OF HF LEAKAGE CURRENT

The HF leakage current can be a cause of not desired burning of patients and because of this reason the Rules state specific requirements and limits (different for units with output circuit completely floating as our units or circuit reference to earth) to be fulfilled.

These controls can be performed in different ways, all accepted from the Rules.

The first way is with output standard leads, but this system isn't easy because it is necessary a wide insulated table able to contain the unit, the instruments needed and the output leads completely laid straight.

In this case the limit accepted is a leakage of 150 mA.

The second one, useable only for the monopolar section of the ESU, is the easiest because is performed directly at the unit terminals with the output leads as shortest as possible and so the insulated table can be smaller. In this case the limit accepted is a leakage of 100 mA

In every case this control must be performed according to the following general warnings :

- All different test conditions must strictly respect the specific requirements detailed in the section 19.3.101 (point a) 2, a) 3, b), c)) of the International Standard IEC 60601-2-2
- The testing instruments are extremely important because can produce big errors of reading.

For example many automatic testers require the contemporary connection of all cables needed for the test (active cable, neutral plate cable and "cable used to do the measure"). This kind of connection doesn't allow to respect (performing the test with output leads) the requirement of the distance among leads (between active and neutral lead 50 cm, between active or neutral lead and lead needed to do the measurement 25 cm) and produces a not real increasing of the leakage.

Because of this reason it is, at least, necessary to use this kind of instruments checking if the value detected following the Standard Use manual of instruments corresponds to the value detected fulfilling the testing requirements of the Rules that state as necessary a distance of 50 cm. between active and neutral plate cables. Practically that means, using an automatic tester:

"to have a correct reading it is necessary to disconnect from the instrument the cable opposite to that tested"

- When the control is performed using an analogic thermocouple RMS instrument (with reading from 0 to 250 or 500 mA) it is possible to damage it because of a mistake of connection and so it is always advisable to do first the reading using an instrument with a higher range (for example 0-1,5 A) to do a first control reading
- the accessories and the connection leads used to perform the measures with output leads must be those standard supplied with the device
- all measurements must be performed only on insulated tables (distance: 1 mt. from a surface earthed (the floor))
- during the tests the connection leads, the instruments or the accessories connected to the unit can't be touched for any reason in order to avoid every contact towards the earth that would falsify the reliability of the measurement increasing it.

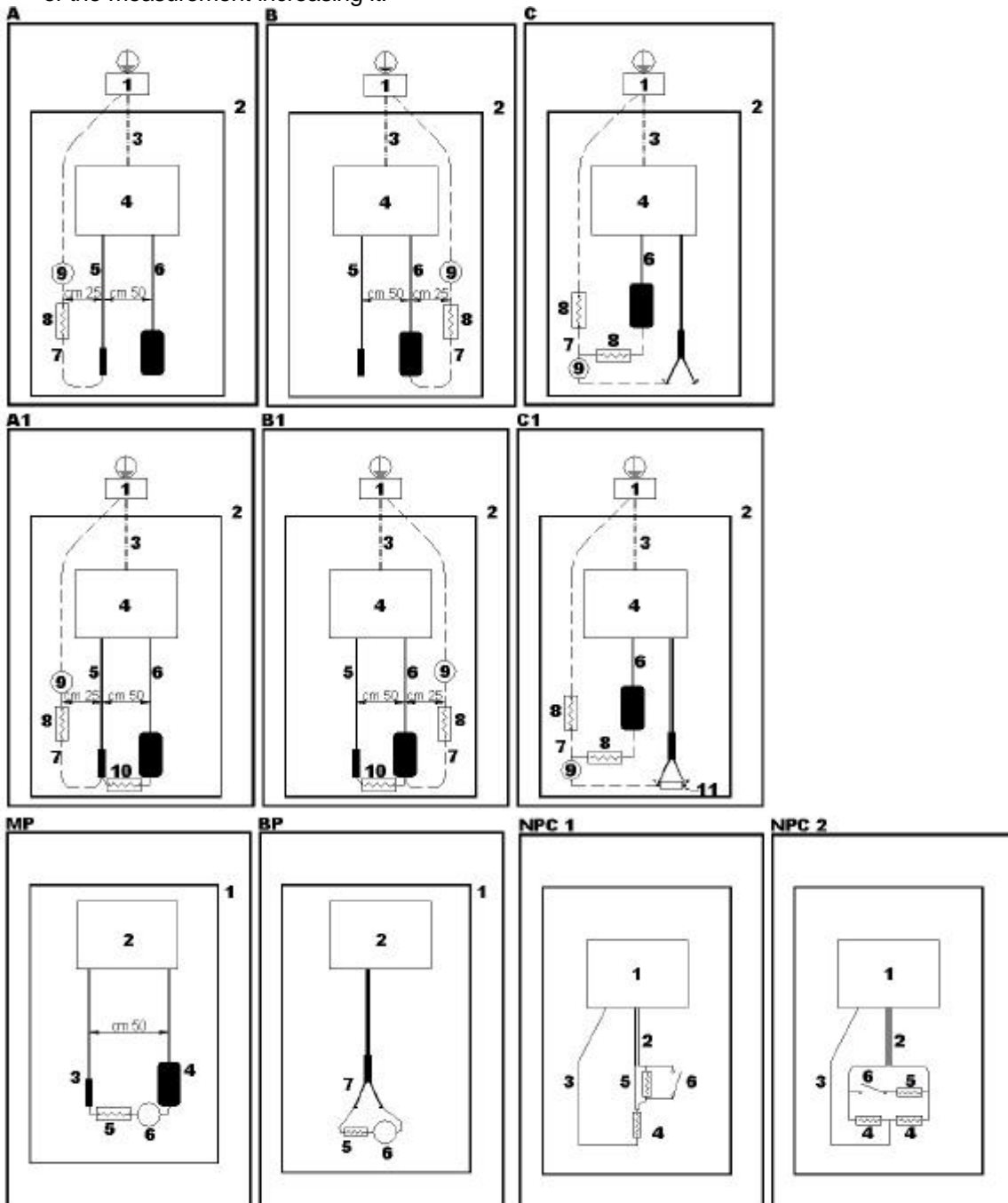

Measurements of leakage current on monopolar section directly at the HF unit terminals (maximum limit 100 mA) performed according to requirements of Par. 19.3.101 b) of International Standard IEC 60601-2-2 III Ed. – 1998 pag. 17

Active electrode (without rated load)

- 1) Set up the unit, leads and instruments as shown in the figure A (see below) with all the leads as shortest as possible (active and neutral leads the minimum possible - about 20 cm)
- 2) Put the unit on the table

- 3) Connect the unit to the mains outlet with the power supply cord (the metallic casing is earthed by means of the earth connection of the same cord)
- 4) Lay on the table all different leads (5,6,7) and connect measuring resistance and HF current meter
- 5) Connect to the earth the cable needed for the measurement (to the mains outlet of point 3)
- 6) Set the maximum power for every available monopolar function and activate the unit using the foot pedal checking by the HF current meter the current flowing to earth

Active electrode (with rated load)

Repeat the same measurement with the rated load (antinductive load of 400 ohm) connected between active and neutral electrodes.

Set up the unit, leads and instruments as shown in the figure A 1 (see below)

Legend: 1) mains outlet perfectly connected to ground

2) perfectly insulated table (with a distance of 1 mt. from the surface connected to ground – wall)

3) power supply cord (folded up to form a bundle having a length not exceeding 40 cm.)

4) HF unit

5) active electrode

6) neutral plate

7) cable needed to do the measurements

8) measuring resistance (antinductive - 200 ohm - at least of 10 Watt)

9) HF current meter (reading instrument)

NEUTRAL PLATE

Repeat for the neutral plate the same procedure above detailed for the active electrode.

Set up the unit, leads and instruments as shown in the figure B (see below)

As for the bipolar functions, the maximum admissible dispersion current must be less than 1% of the maximum power that may be output by the function in question. For functions which output 99 W, this current must remain below *70 mA*, for functions which output 80 W, the admissible limit is equal to *63 mA* and finally for functions which output 60 W, the limit is *54 mA*.

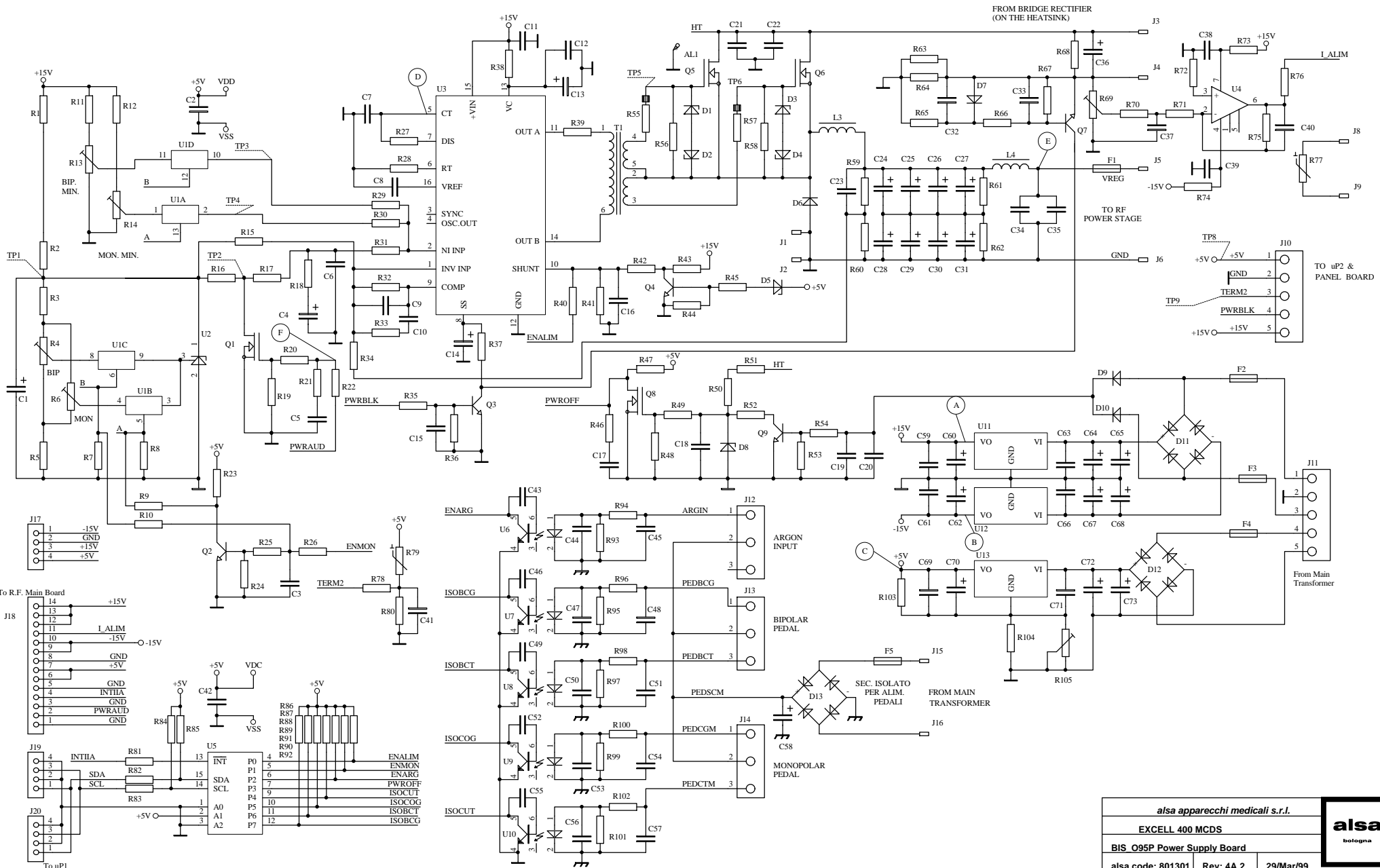

<i>alsa apparecchi medicali s.r.l.</i>		
EXCELL 400 MCDS		
BIS O95P Power Supply Board		
alsa code: 801301	Rev: 4A.2	29/Mar/99
Drawn by:	Approval:	



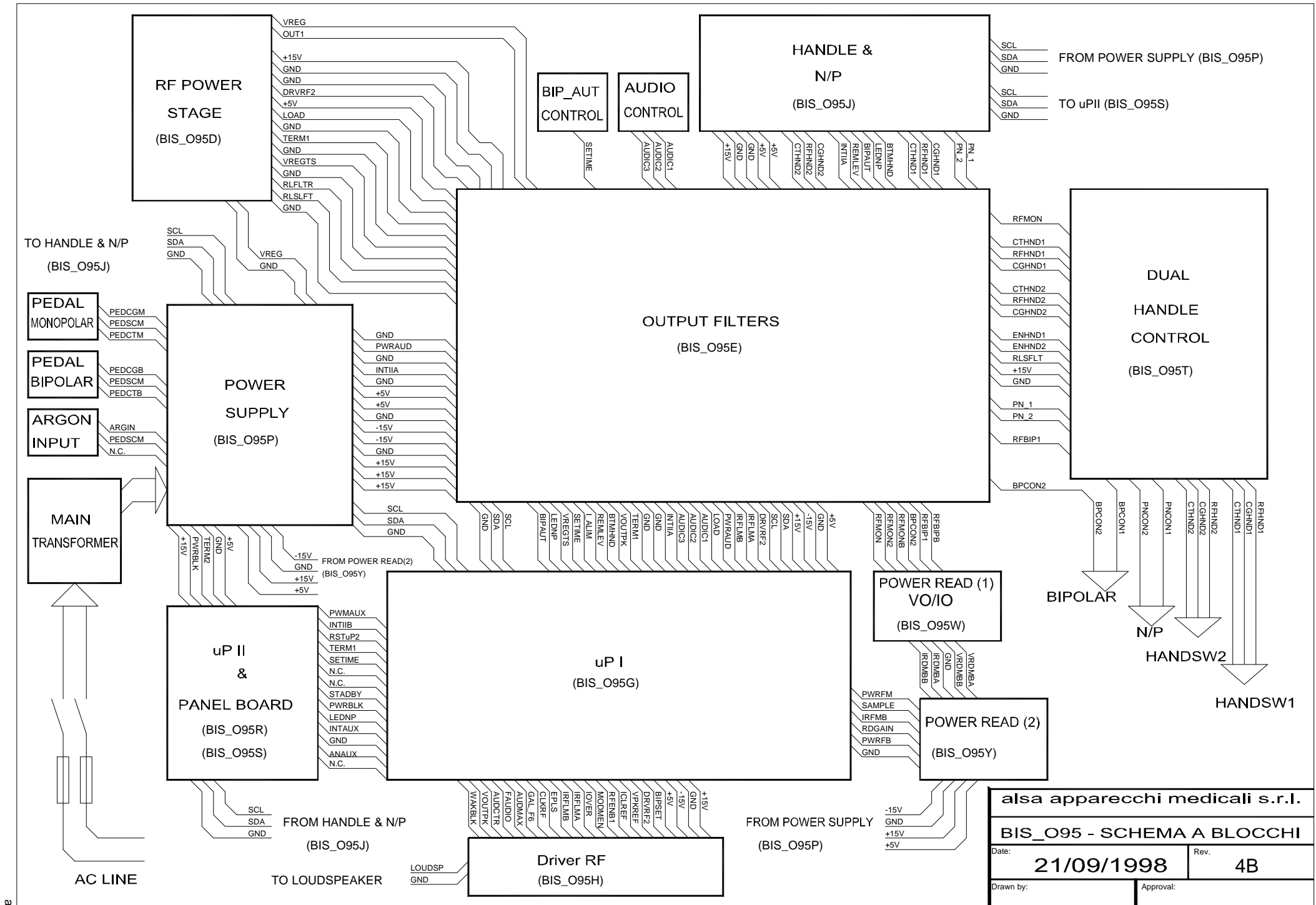

alsa apparecchi medicali s.r.l.	
BIS_095 - SCHEMA A BLOCCHI	
Date:	Rev.
21/09/1998	4B
Drawn by:	Approval:

ELECTROSURGICAL UNIT EXCELL 400 MCDS**POWER SUPPLY BOARD****also code: 801301 Rev.: 4A.2****Last revised: 29-mar-99 Date: 12-gen-00 13.24**

Reference	Part Type	Description	also code
R1	150	METAL FILM RESISTOR 1/4 W 5%	430434
R2	150	METAL FILM RESISTOR 1/4 W 5%	430434
R3	8K/1%	PRECISION RESISTOR 1% 0.6W	430469
R4	2KT	PRESET POTENTIOMETER CERMET	403092
R5	5K/1%	PRECISION RESISTOR 1% 0.6W	430490
R6	2KT	PRESET POTENTIOMETER CERMET	403092
R7	33K	METAL FILM RESISTOR 1/4 W 5%	430172
R8	33K	METAL FILM RESISTOR 1/4 W 5%	430172
R9	1K	METAL FILM RESISTOR 1/4 W 5%	430170
R10	1K	METAL FILM RESISTOR 1/4 W 5%	430170
R11	18K	METAL FILM RESISTOR 1/4 W 5%	430346
R12	18K	METAL FILM RESISTOR 1/4 W 5%	430346
R13	5KT	PRESET POTENTIOMETER CERMET	403052
R14	5KT	PRESET POTENTIOMETER CERMET	403052
R15	150K	METAL FILM RESISTOR 1/4 W 5%	430360
R16	1K	METAL FILM RESISTOR 1/4 W 5%	430170
R17	100K	METAL FILM RESISTOR 1/4 W 5%	430177
R18	10K	METAL FILM RESISTOR 1/4 W 5%	430339
R19	100K	METAL FILM RESISTOR 1/4 W 5%	430177
R20	1K	METAL FILM RESISTOR 1/4 W 5%	430170
R21	100	METAL FILM RESISTOR 1/4 W 5%	430336
R22	1K	METAL FILM RESISTOR 1/4 W 5%	430170
R23	4K7	METAL FILM RESISTOR 1/4 W 5%	430167
R24	47K	METAL FILM RESISTOR 1/4 W 5%	430218
R25	47K	METAL FILM RESISTOR 1/4 W 5%	430218
R26	1K	METAL FILM RESISTOR 1/4 W 5%	430170
R27	10	METAL FILM RESISTOR 1/4 W 5%	430180
R28	12K	METAL FILM RESISTOR 1/4 W 5%	430351
R29	220K	METAL FILM RESISTOR 1/4 W 5%	430352
R30	220K	METAL FILM RESISTOR 1/4 W 5%	430352
R31	10K	METAL FILM RESISTOR 1/4 W 5%	430339
R32	470K	METAL FILM RESISTOR 1/4 W 5%	430455
R33	27K	METAL FILM RESISTOR 1/4 W 5%	430340
R34	10K	METAL FILM RESISTOR 1/4 W 5%	430339
R35	1K	METAL FILM RESISTOR 1/4 W 5%	430170
R36	10K	METAL FILM RESISTOR 1/4 W 5%	430339
R37	10	METAL FILM RESISTOR 1/4 W 5%	430180
R38	10	METAL FILM RESISTOR 1/4 W 5%	430180
R39	10	METAL FILM RESISTOR 1/4 W 5%	430180
R40	10K	METAL FILM RESISTOR 1/4 W 5%	430339
R41	22K	METAL FILM RESISTOR 1/4 W 5%	430179
R42	22K	METAL FILM RESISTOR 1/4 W 5%	430179
R43	47K	METAL FILM RESISTOR 1/4 W 5%	430218
R44	10K	METAL FILM RESISTOR 1/4 W 5%	430339
R45	4K7	METAL FILM RESISTOR 1/4 W 5%	430167
R46	100	METAL FILM RESISTOR 1/4 W 5%	430336
R47	1K	METAL FILM RESISTOR 1/4 W 5%	430170
R48	100K	METAL FILM RESISTOR 1/4 W 5%	430177
R49	10K	METAL FILM RESISTOR 1/4 W 5%	430339
R50	220K	METAL FILM RESISTOR 1/4 W 5%	430352
R51	220K	METAL FILM RESISTOR 1/4 W 5%	430352
R52	10	METAL FILM RESISTOR 1/4 W 5%	430180
R53	2K2	METAL FILM RESISTOR 1/4 W 5%	430343
R54	10K	METAL FILM RESISTOR 1/4 W 5%	430339
R55	22	METAL FILM RESISTOR 1/4 W 5%	430447
R56	1K	METAL FILM RESISTOR 1/4 W 5%	430170
R57	22	METAL FILM RESISTOR 1/4 W 5%	430447
R58	1K	METAL FILM RESISTOR 1/4 W 5%	430170
R59	100K	METAL FILM RESISTOR 1/4 W 5%	430177

Reference	Part Type	Description	alsa code
R60	3K3	METAL FILM RESISTOR 1/4 W 5%	430197
R61	4K7/3W/F	METAL FILM RESISTOR 1 W	430470
R62	4K7/3W/F	METAL FILM RESISTOR 1 W	430470
R63	0.22/2W	METAL FILM RESISTOR 2 W	430439
R64	0.22/2W	METAL FILM RESISTOR 2 W	430439
R65	1K	METAL FILM RESISTOR 1/4 W 5%	430170
R66	680	METAL FILM RESISTOR 1/4 W 5%	430194
R67	10K	METAL FILM RESISTOR 1/4 W 5%	430339
R68	33K/6W/F	WIREWOUND RESISTOR 33 K 6 W	430463
R69	100T	PRESET POTENTIOMETER CERMET	403029
R70	3K3	METAL FILM RESISTOR 1/4 W 5%	430197
R71	100	METAL FILM RESISTOR 1/4 W 5%	430336
R72	820	METAL FILM RESISTOR 1/4 W 5%	430200
R73	12	METAL FILM RESISTOR 1/4 W 5%	430415
R74	12	METAL FILM RESISTOR 1/4 W 5%	430415
R75	150K	METAL FILM RESISTOR 1/4 W 5%	430360
R76	100	METAL FILM RESISTOR 1/4 W 5%	430336
R77	NU	NOT USED	-----
R78	220	METAL FILM RESISTOR 1/4 W 5%	430358
R79	NTC_V47K	NTC THERMISTOR THREADED 47K 5%	430452
R80	11K/1%	PRECISION RESISTOR 1% 0.6W	430467
R81	100	METAL FILM RESISTOR 1/4 W 5%	430336
R82	220	METAL FILM RESISTOR 1/4 W 5%	430358
R83	220	METAL FILM RESISTOR 1/4 W 5%	430358
R84	5K6	METAL FILM RESISTOR 1/4 W 5%	430344
R85	5K6	METAL FILM RESISTOR 1/4 W 5%	430344
R86	1K	METAL FILM RESISTOR 1/4 W 5%	430170
R87	1K	METAL FILM RESISTOR 1/4 W 5%	430170
R88	1K	METAL FILM RESISTOR 1/4 W 5%	430170
R89	1K	METAL FILM RESISTOR 1/4 W 5%	430170
R90	1K	METAL FILM RESISTOR 1/4 W 5%	430170
R91	1K	METAL FILM RESISTOR 1/4 W 5%	430170
R92	1K	METAL FILM RESISTOR 1/4 W 5%	430170
R93	150	METAL FILM RESISTOR 1/4 W 5%	430434
R94	330	METAL FILM RESISTOR 1/4 W 5%	430171
R95	150	METAL FILM RESISTOR 1/4 W 5%	430434
R96	330	METAL FILM RESISTOR 1/4 W 5%	430171
R97	150	METAL FILM RESISTOR 1/4 W 5%	430434
R98	330	METAL FILM RESISTOR 1/4 W 5%	430171
R99	150	METAL FILM RESISTOR 1/4 W 5%	430434
R100	330	METAL FILM RESISTOR 1/4 W 5%	430171
R101	150	METAL FILM RESISTOR 1/4 W 5%	430434
R102	330	METAL FILM RESISTOR 1/4 W 5%	430171
R103	1K/1%	PRECISION RESISTOR 1% 0.6W	430458
R104	27	METAL FILM RESISTOR 1/4 W 5%	430158
R105	100T	PRESET POTENTIOMETER CERMET	403029
C1	10u/T/35V	TANTALUM ELECTROLYTIC CAPACITOR	400134
C2	100n	CERAMIC CAPACITOR	400139
C3	100n	CERAMIC CAPACITOR	400139
C4	1u/T/35V	TANTALUM ELECTROLYTIC CAPACITOR	400173
C5	22p/C	CERAMIC CAPACITOR	400290
C6	100n	CERAMIC CAPACITOR	400139
C7	1n/P	METALLIZED POLYESTER CAPACITOR	400278
C8	100n	CERAMIC CAPACITOR	400139
C9	100p/NPO	NPO CERAMIC CAPACITOR	400260
C10	220p/C	CERAMIC CAPACITOR	400240
C11	100n	CERAMIC CAPACITOR	400139
C12	100n	CERAMIC CAPACITOR	400139
C13	10u/T/35V	TANTALUM ELECTROLYTIC CAPACITOR	400134
C14	1u/T/35V	TANTALUM ELECTROLYTIC CAPACITOR	400173
C15	100n	CERAMIC CAPACITOR	400139
C16	100n	CERAMIC CAPACITOR	400139
C17	100n	CERAMIC CAPACITOR	400139

Reference	Part Type	Description	alsa code
C18	470n/P	METALLIZED POLYESTER CAPACITOR	400309
C19	100n	CERAMIC CAPACITOR	400139
C20	100n	CERAMIC CAPACITOR	400139
C21	10n/C/1KV	CERAMIC CAPACITOR	400133
C22	10n/C/1KV	CERAMIC CAPACITOR	400133
C23	1n/C/3KV	HIGH VOLTAGE CERAMIC CAPACITOR	400224
C24	22u/E/100V/V	VERTICAL ELECTROLYTIC CAPACITOR SMPS	400286
C25	22u/E/100V/V	VERTICAL ELECTROLYTIC CAPACITOR SMPS	400286
C26	22u/E/100V/V	VERTICAL ELECTROLYTIC CAPACITOR SMPS	400286
C27	22u/E/100V/V	VERTICAL ELECTROLYTIC CAPACITOR SMPS	400286
C28	22u/E/100V/V	VERTICAL ELECTROLYTIC CAPACITOR SMPS	400286
C29	22u/E/100V/V	VERTICAL ELECTROLYTIC CAPACITOR SMPS	400286
C30	22u/E/100V/V	VERTICAL ELECTROLYTIC CAPACITOR SMPS	400286
C31	22u/E/100V/V	VERTICAL ELECTROLYTIC CAPACITOR SMPS	400286
C32	2n2/C	CERAMIC CAPACITOR	400261
C33	1n/C	CERAMIC CAPACITOR	400252
C34	10n/C/1KV	CERAMIC CAPACITOR	400133
C35	10n/C/1KV	CERAMIC CAPACITOR	400133
C36	470u/E/250V	VERTICAL ELECTROLYTIC CAPACITOR	400304
C37	100n	CERAMIC CAPACITOR	400139
C38	100n	CERAMIC CAPACITOR	400139
C39	100n	CERAMIC CAPACITOR	400139
C40	220n/P	METALLIZED FILM CAPACITOR	400271
C41	100n	CERAMIC CAPACITOR	400139
C42	100n	CERAMIC CAPACITOR	400139
C43	100n	CERAMIC CAPACITOR	400139
C44	100n	CERAMIC CAPACITOR	400139
C45	100n	CERAMIC CAPACITOR	400139
C46	100n	CERAMIC CAPACITOR	400139
C47	100n	CERAMIC CAPACITOR	400139
C48	100n	CERAMIC CAPACITOR	400139
C49	100n	CERAMIC CAPACITOR	400139
C50	100n	CERAMIC CAPACITOR	400139
C51	100n	CERAMIC CAPACITOR	400139
C52	100n	CERAMIC CAPACITOR	400139
C53	100n	CERAMIC CAPACITOR	400139
C54	100n	CERAMIC CAPACITOR	400139
C55	100n	CERAMIC CAPACITOR	400139
C56	100n	CERAMIC CAPACITOR	400139
C57	100n	CERAMIC CAPACITOR	400139
C58	220u/E/16V	ELECTROLYTIC CAPACITOR	400274
C59	100n	CERAMIC CAPACITOR	400139
C60	10u/T/35V	TANTALUM ELECTROLYTIC CAPACITOR	400134
C61	100n	CERAMIC CAPACITOR	400139
C62	10u/T/35V	TANTALUM ELECTROLYTIC CAPACITOR	400134
C63	100n	CERAMIC CAPACITOR	400139
C64	1000u/E/35V	ELECTROLYTIC CAPACITOR	400256
C65	1000u/E/35V	ELECTROLYTIC CAPACITOR	400256
C66	100n	CERAMIC CAPACITOR	400139
C67	1000u/E/35V	ELECTROLYTIC CAPACITOR	400256
C68	1000u/E/35V	ELECTROLYTIC CAPACITOR	400256
C69	100n	CERAMIC CAPACITOR	400139
C70	10u/T/35V	TANTALUM ELECTROLYTIC CAPACITOR	400134
C71	100n	CERAMIC CAPACITOR	400139
C72	1000u/E/35V	ELECTROLYTIC CAPACITOR	400256
C73	1000u/E/35V	ELECTROLYTIC CAPACITOR	400256
D1	12V/1W	ZENER DIODE 12V/1W	420019
D2	12V/1W	ZENER DIODE 12V/1W	420019
D3	12V/1W	ZENER DIODE 12V/1W	420019
D4	12V/1W	ZENER DIODE 12V/1W	420019
D5	2V7/0.5W	ZENER DIODE 2V7-1/2W	420067
D6	BYT03/400	ULTRA FAST DIODE 3A/400V	420071
D7	1N4148	DIODE	420010

Reference	Part Type	Description	alsa code
D8	12V/0.5W	ZENER DIODE 12V-1/2W	420083
D9	1N4148	DIODE	420010
D10	1N4148	DIODE	420010
D11	KBL06	BRIDGE RECTIFIER 4A/600V	420069
D12	KBL06	BRIDGE RECTIFIER 4A/600V	420069
D13	WL04	BRIDGE RECTIFIER 1A	420013
Q1	VN10KM	N CHANNEL MOSFET	427054
Q2	BC237B	NPN TRANSISTOR	427057
Q3	BC237B	NPN TRANSISTOR	427057
Q4	BC237B	NPN TRANSISTOR	427057
Q5	IRF740	N CHANNEL MOSFET	427076
Q6	IRF740	N CHANNEL MOSFET	427076
Q7	2N2222A	NPN TRANSISTOR	427041
Q8	VN10KM	N CHANNEL MOSFET	427054
Q9	BC237B	NPN TRANSISTOR	427057
L3	713669	INDUCTOR 1 MH	713669
L4	NU	NOT USED	-----
U1	4066	CMOS CD4066	482017
U2	LM431	VOLTAGE REGULATOR	482078
U3	UC3525	PWM UC3525	482060
U4	TL071	OP.AMP. TL071	482018
U5	PCF8574	II_CBUS I/O EXPANDER	482089
U6	SFH600-2	OPTOCOUPLER SFH600-2	482022
U7	SFH600-2	OPTOCOUPLER SFH600-2	482022
U8	SFH600-2	OPTOCOUPLER SFH600-2	482022
U9	SFH600-2	OPTOCOUPLER SFH600-2	482022
U10	SFH600-2	OPTOCOUPLER SFH600-2	482022
U11	LM78S15	VOLTAGE REGULATOR +15V	482086
U12	LM7915	VOLTAGE REGULATOR -15V	482087
U13	LM78S05	VOLTAGE REGULATOR +5V	482097
T1	421026	PULSE TRANSFORMER (2 SECONDARIES)	421026
F1	5A/T	FUSE 5 A T 5X20 MM	433048
F2	2A/T	FUSE 2 A T 5X20 MM	433001
F3	2A/T	FUSE 2 A T 5X20 MM	433001
F4	2A/T	FUSE 2 A T 5X20 MM	433001
F5	100mA/T	FUSE 100 MA T 5X20 MM	433046
J1	399028	FASTON CONNECTOR P.C.B.	399028
J2	399028	FASTON CONNECTOR P.C.B.	399028
J3	399028	FASTON CONNECTOR P.C.B.	399028
J4	399028	FASTON CONNECTOR P.C.B.	399028
J5	399028	FASTON CONNECTOR P.C.B.	399028
J6	399028	FASTON CONNECTOR P.C.B.	399028
J8	NU	NOT USED	-----
J9	NU	NOT USED	-----
J10	384016	5 POLES PCB CONNECTOR MASCON	384016
J11	384016	5 POLES PCB CONNECTOR MASCON	384016
J12	PAND_3P	3 POLES PCB CONNECTOR PANDUIT MALE	384036
J13	PAND_3P	3 POLES PCB CONNECTOR PANDUIT MALE	384036
J14	PAND_3P	3 POLES PCB CONNECTOR PANDUIT MALE	384036
J15	399028	FASTON CONNECTOR P.C.B.	399028
J16	399028	FASTON CONNECTOR P.C.B.	399028
J17	PICO_4	4 POLES PICOFLEX CONN. MALE P.C.B.	384042
J18	PICO_14	14 POLES PICOFLEX CONN. MALE P.C.B.	384040
J19	PICO_4	4 POLES PICOFLEX CONN. MALE P.C.B.	384042
J20	PICO_4	4 POLES PICOFLEX CONN. MALE P.C.B.	384042
AL1	ART_59_VER	ALUMINIUM HEAT SINK	713885

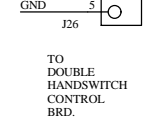
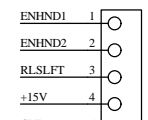
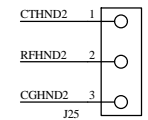
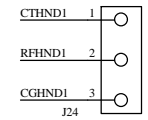
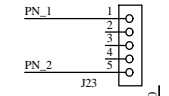
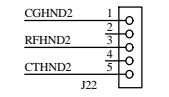
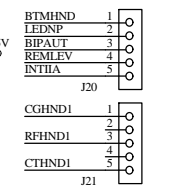
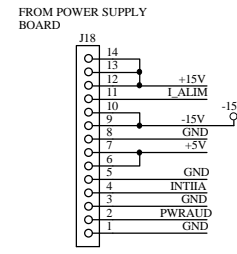
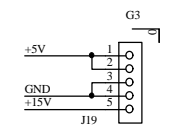
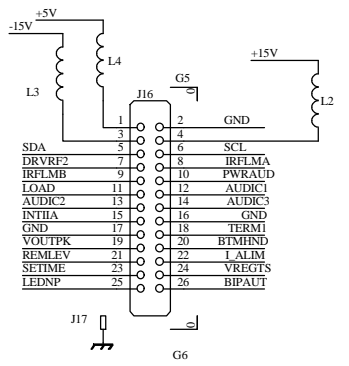
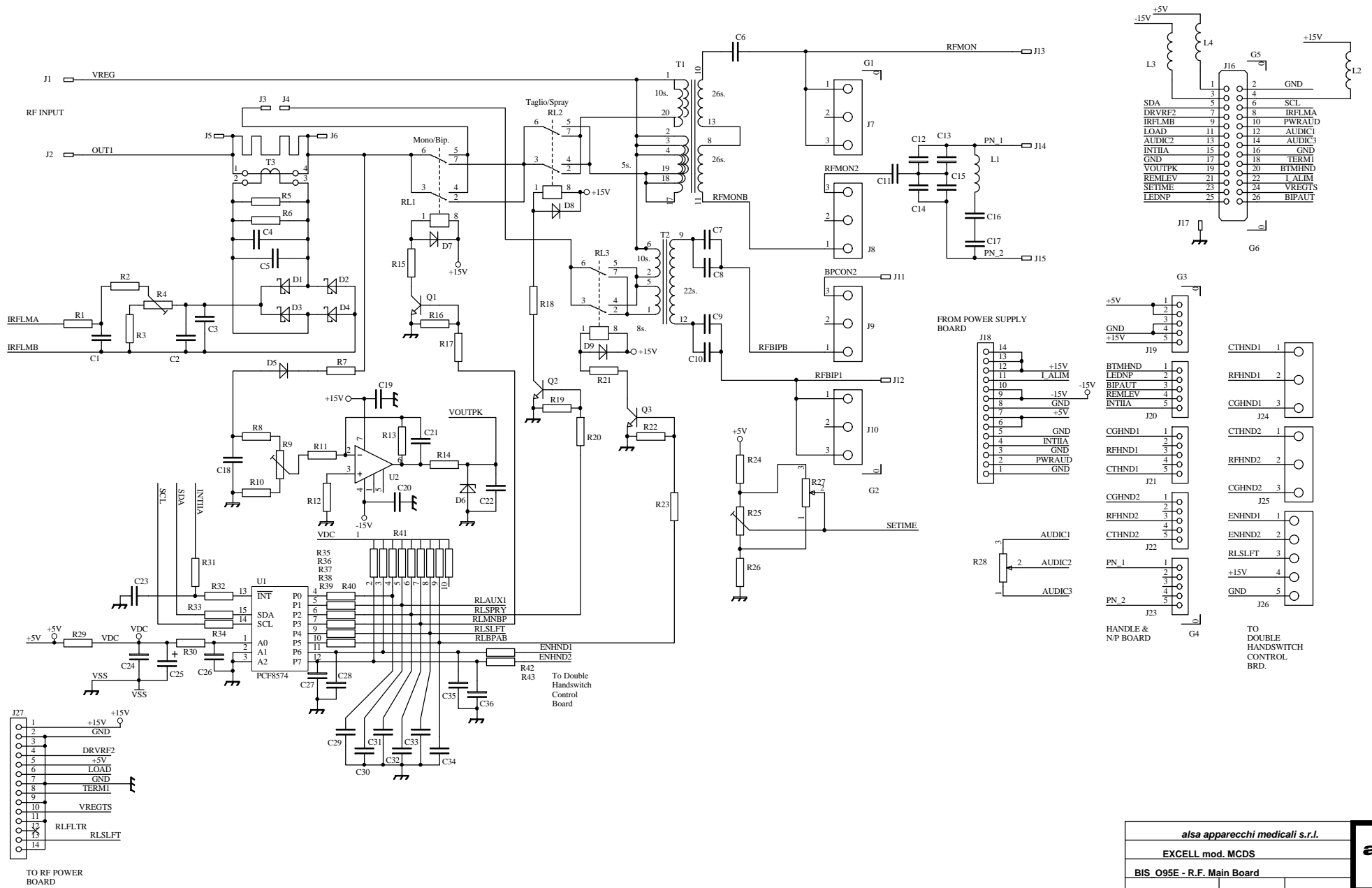

alsap apparecchi medicali s.r.l.		
EXCELL mod. MCDS		
BIS 095E - R.F. Main Board		
alsap code: 801302	Rev: 4B.2	29/Mar/99
Drawn by:	Approval:	



ELECTROSURGICAL UNIT EXCELL 400 MCDS**R.F. MAIN BOARD****also code: 801302 Rev.: 4B.3****Last revised: 8-Sep-99 Date: 12-gen-00 13.25**

Reference	Part Type	Description	also code
R1	1K	METAL FILM RESISTOR 1/4 W 5%	430170
R2	220	METAL FILM RESISTOR 1/4 W 5%	430358
R3	2K2	METAL FILM RESISTOR 1/4 W 5%	430343
R4	2KT	PRESET POTENTIOMETER CERMET	403092
R5	560	METAL FILM RESISTOR 1/4 W 5%	430178
R6	560	METAL FILM RESISTOR 1/4 W 5%	430178
R7	100/0.5W	METAL FILM RESISTOR 1/2 W 5%	430107
R8	33K	METAL FILM RESISTOR 1/4 W 5%	430172
R9	10KT	PRESET POTENTIOMETER CERMET	403066
R10	5K6	METAL FILM RESISTOR 1/4 W 5%	430344
R11	100K	METAL FILM RESISTOR 1/4 W 5%	430177
R12	47K	METAL FILM RESISTOR 1/4 W 5%	430218
R13	100K	METAL FILM RESISTOR 1/4 W 5%	430177
R14	560	METAL FILM RESISTOR 1/4 W 5%	430178
R15	47	METAL FILM RESISTOR 1/4 W 5%	430334
R16	100K	METAL FILM RESISTOR 1/4 W 5%	430177
R17	10K	METAL FILM RESISTOR 1/4 W 5%	430339
R18	47	METAL FILM RESISTOR 1/4 W 5%	430334
R19	100K	METAL FILM RESISTOR 1/4 W 5%	430177
R20	10K	METAL FILM RESISTOR 1/4 W 5%	430339
R21	47	METAL FILM RESISTOR 1/4 W 5%	430334
R22	100K	METAL FILM RESISTOR 1/4 W 5%	430177
R23	10K	METAL FILM RESISTOR 1/4 W 5%	430339
R24	1K	METAL FILM RESISTOR 1/4 W 5%	430170
R25	NU	NOT USED	-----
R26	1K	METAL FILM RESISTOR 1/4 W 5%	430170
R27	10KP/D	DUAL POTENTIOMETER	403099
R28	10KP/D	DUAL POTENTIOMETER	403099
R29	12	METAL FILM RESISTOR 1/4 W 5%	430415
R30	220	METAL FILM RESISTOR 1/4 W 5%	430358
R31	100	METAL FILM RESISTOR 1/4 W 5%	430336
R32	100	METAL FILM RESISTOR 1/4 W 5%	430336
R33	220	METAL FILM RESISTOR 1/4 W 5%	430358
R34	220	METAL FILM RESISTOR 1/4 W 5%	430358
R35	NU	NOT USED	-----
R36	100	METAL FILM RESISTOR 1/4 W 5%	430336
R37	100	METAL FILM RESISTOR 1/4 W 5%	430336
R38	100	METAL FILM RESISTOR 1/4 W 5%	430336
R39	100	METAL FILM RESISTOR 1/4 W 5%	430336
R40	100	METAL FILM RESISTOR 1/4 W 5%	430336
R41	X_RNET2K2	RESISTOR NETWORK 2K2	430485
R42	10K	METAL FILM RESISTOR 1/4 W 5%	430339
R43	10K	METAL FILM RESISTOR 1/4 W 5%	430339
C1	1n/C	CERAMIC CAPACITOR	400252
C2	100n	CERAMIC CAPACITOR	400139
C3	100n	CERAMIC CAPACITOR	400139
C4	560p/C/500V	CERAMIC CAPACITOR	400294
C5	560p/C/500V	CERAMIC CAPACITOR	400294
C6	4N7/PP/2KV	POLYPROPYLENE CAPACITOR	400306
C7	3n3/PP/2KV	POLYPROPYLENE CAPACITOR	400232
C8	3n3/PP/2KV	POLYPROPYLENE CAPACITOR	400232
C9	3n3/PP/2KV	POLYPROPYLENE CAPACITOR	400232
C10	3n3/PP/2KV	POLYPROPYLENE CAPACITOR	400232
C11	4N7/PP/2KV	POLYPROPYLENE CAPACITOR	400306
C12	220n/PP/400V	POLYPROPYLENE CAPACITOR (SIEMENS)	400297
C13	220n/PP/400V	POLYPROPYLENE CAPACITOR (SIEMENS)	400297
C14	220n/PP/400V	POLYPROPYLENE CAPACITOR (SIEMENS)	400297
C15	220n/PP/400V	POLYPROPYLENE CAPACITOR (SIEMENS)	400297
C16	NU	NOT USED	-----

Reference	Part Type	Description	also code
C17	NU	NOT USED	-----
C18	100n/P	METALLIZED FILM CAPACITOR	400250
C19	100n	CERAMIC CAPACITOR	400139
C20	100n	CERAMIC CAPACITOR	400139
C21	100n	CERAMIC CAPACITOR	400139
C22	100p/NPO	NPO CERAMIC CAPACITOR	400260
C23	10n	CERAMIC CAPACITOR	400251
C24	100n	CERAMIC CAPACITOR	400139
C25	220u/E/16V	ELECTROLYTIC CAPACITOR	400274
C26	100n	CERAMIC CAPACITOR	400139
C27	10n	CERAMIC CAPACITOR	400251
C28	10n	CERAMIC CAPACITOR	400251
C29	10n	CERAMIC CAPACITOR	400251
C30	10n	CERAMIC CAPACITOR	400251
C31	10n	CERAMIC CAPACITOR	400251
C32	10n	CERAMIC CAPACITOR	400251
C33	10n	CERAMIC CAPACITOR	400251
C34	10n	CERAMIC CAPACITOR	400251
C35	100n	CERAMIC CAPACITOR	400139
C36	100n	CERAMIC CAPACITOR	400139
D1	BAT83	SCHOTTKY DIODE	420070
D2	BAT83	SCHOTTKY DIODE	420070
D3	BAT83	SCHOTTKY DIODE	420070
D4	BAT83	SCHOTTKY DIODE	420070
D5	BYR29-800	DIODO ULTRA FAST	420095
D6	10V/0.5W	ZENER DIODE 10V-1/2W	420068
D7	1N4007	DIODE	420001
D8	1N4007	DIODE	420001
D9	1N4007	DIODE	420001
Q1	BC547	NPN TRANSISTOR	427057
Q2	BC547	NPN TRANSISTOR	427057
Q3	BC547	NPN TRANSISTOR	427057
L1	NU	NOT USED	-----
L2	6uH8/800mA	INDUCTOR	422007
L3	6uH8/800mA	INDUCTOR	422007
L4	6uH8/800mA	INDUCTOR	422007
U1	PCF8574	II_CBUS I/O EXPANDER	482089
U2	TL071	OP.AMP. TL071	482018
RL1	40.52-12VDC	RELAY OMRON	404040
RL2	40.52-12VDC	RELAY OMRON	404040
RL3	40.52-12VDC	RELAY OMRON	404040
T1	TRAS_ML1	MONOPOLAR OUTPUT TRANSFORMER (400 MCDS)	801319
T2	RM_14S3	BIPOLAR OUTPUT TRANSFORMER (400 MCDS)	801320
T3	CURTRAN	CURRENT TRANSFORMER	713909
J1	399028	FASTON CONNECTOR P.C.B.	399028
J2	399028	FASTON CONNECTOR P.C.B.	399028
J3	PAD_CI	PAD	-----
J4	PAD_CI	PAD	-----
J5	PAD	COMPONENT NOT FOUND	-----
J6	PAD	COMPONENT NOT FOUND	-----
J7	PAND_3P	3 POLES PCB CONNECTOR PANDUIT MALE	384036
J8	PAND_3P	3 POLES PCB CONNECTOR PANDUIT MALE	384036
J9	PAND_3P	3 POLES PCB CONNECTOR PANDUIT MALE	384036
J10	PAND_3P	3 POLES PCB CONNECTOR PANDUIT MALE	384036
J11	399028	FASTON CONNECTOR P.C.B.	399028
J12	399028	FASTON CONNECTOR P.C.B.	399028
J13	399028	FASTON CONNECTOR P.C.B.	399028
J14	399028	FASTON CONNECTOR P.C.B.	399028
J15	399028	FASTON CONNECTOR P.C.B.	399028
J16	PICO_26	26 POLES PICOFLEX CONN. MALE P.C.B.	384044
J17	399028	FASTON CONNECTOR P.C.B.	399028
J18	PICO_14	14 POLES PICOFLEX CONN. MALE P.C.B.	384040
J19	384033	5 POLES CONNECTOR MOLEX MALE	384033

Reference	Part Type	Description	alsa code
J20	384033	5 POLES CONNECTOR MOLEX MALE	384033
J21	384033	5 POLES CONNECTOR MOLEX MALE	384033
J22	384033	5 POLES CONNECTOR MOLEX MALE	384033
J23	384033	5 POLES CONNECTOR MOLEX MALE	384033
J24	PAND_3P	3 POLES PCB CONNECTOR PANDUIT MALE	384036
J25	PAND_3P	3 POLES PCB CONNECTOR PANDUIT MALE	384036
J26	384016	5 POLES PCB CONNECTOR MASCON	384016
J27	PICO_14	14 POLES PICO FLEX CONN. MALE P.C.B.	384040

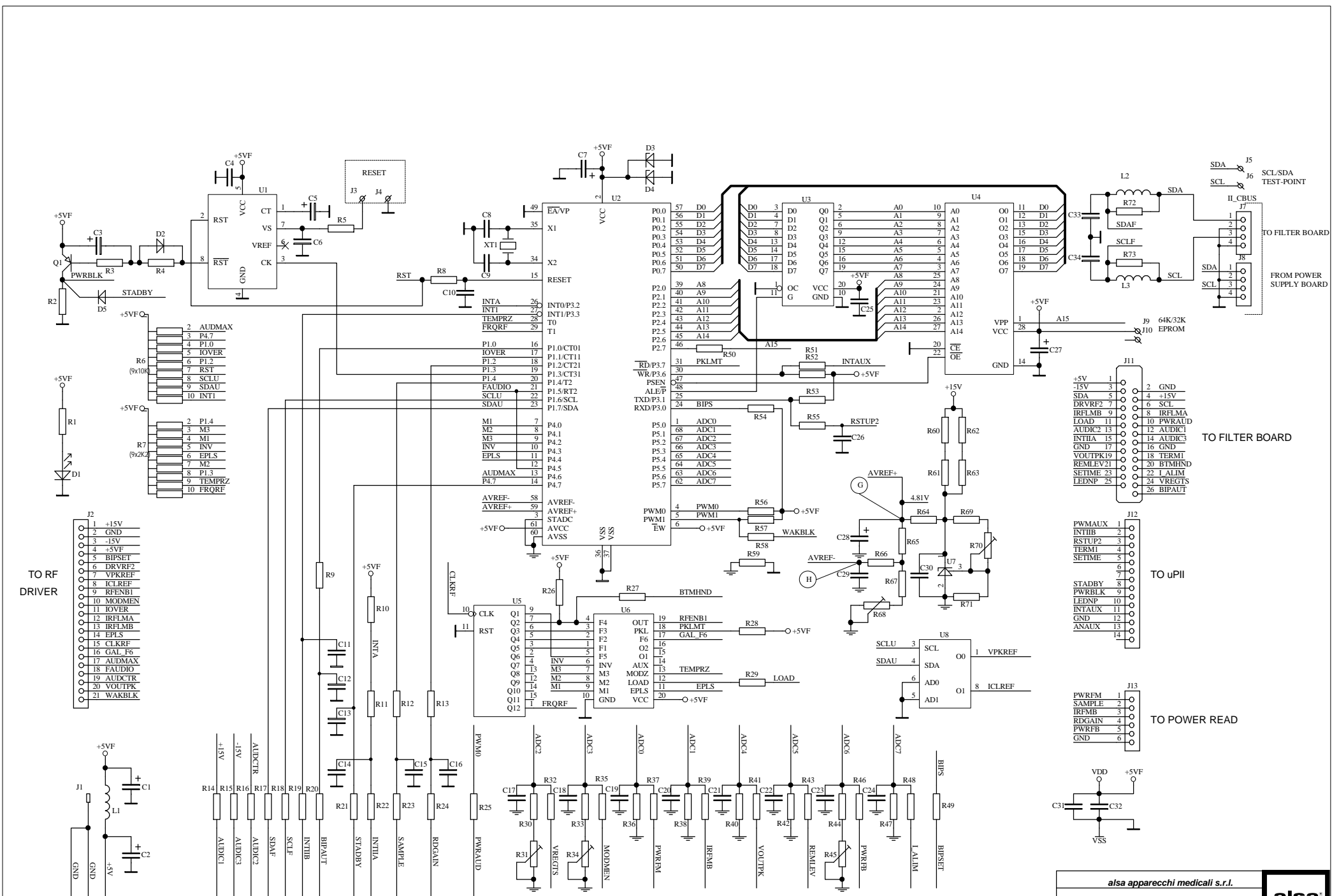

alsa apparecchi medicali s.r.l.		
EXCELL mod. MCDS		
BIS O95G - uC Sistema Dinamico		
cod. alsa: 801303	Rev.: 4B.2	15/Mar/99
Drawn by:	Approval:	

alsa
 botogna

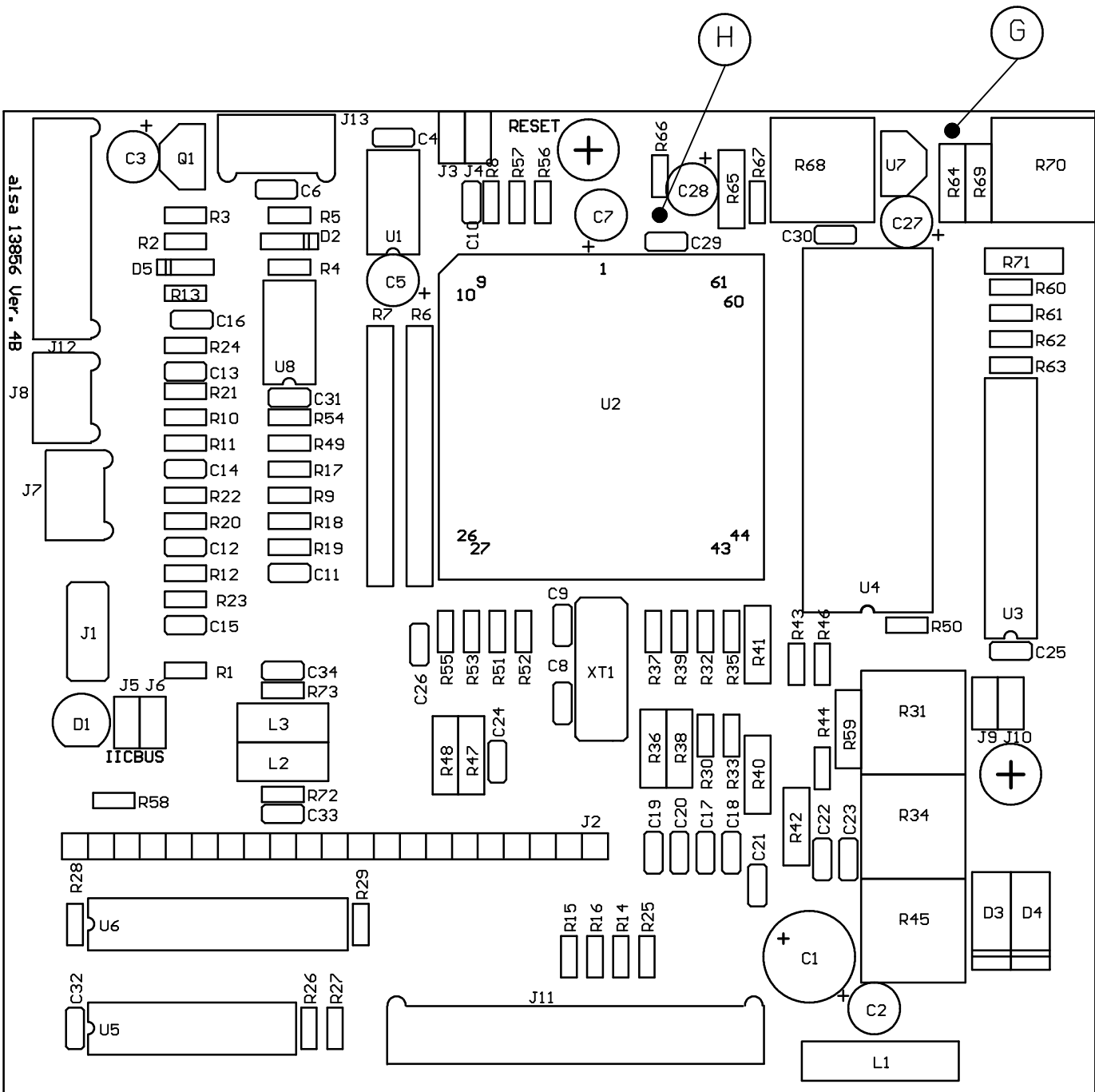

ELECTROSURGICAL UNIT EXCELL 400 MCDS**MICROCONTROLLER BOARD****also code: 801303 Rev.: 4B.2****Last revised: 15-mar-99 Date: 12-gen-00 13.25**

Reference	Part Type	Description	also code
R1	560	METAL FILM RESISTOR 1/4 W 5%	430178
R2	1K5	METAL FILM RESISTOR 1/4 W 5%	430199
R3	10K	METAL FILM RESISTOR 1/4 W 5%	430339
R4	10K	METAL FILM RESISTOR 1/4 W 5%	430339
R5	1K	METAL FILM RESISTOR 1/4 W 5%	430170
R6	X_RNET10	RESISTOR NETWORK 10K	430484
R7	X_RNET2K	RESISTOR NETWORK 2K2	430485
R8	100	METAL FILM RESISTOR 1/4 W 5%	430336
R9	100	METAL FILM RESISTOR 1/4 W 5%	430336
R10	10K	METAL FILM RESISTOR 1/4 W 5%	430339
R11	100	METAL FILM RESISTOR 1/4 W 5%	430336
R12	1K	METAL FILM RESISTOR 1/4 W 5%	430170
R13	1K	METAL FILM RESISTOR 1/4 W 5%	430170
R14	5K6	METAL FILM RESISTOR 1/4 W 5%	430344
R15	4K7	METAL FILM RESISTOR 1/4 W 5%	430167
R16	1K	METAL FILM RESISTOR 1/4 W 5%	430170
R17	100	METAL FILM RESISTOR 1/4 W 5%	430336
R18	100	METAL FILM RESISTOR 1/4 W 5%	430336
R19	470	METAL FILM RESISTOR 1/4 W 5%	430169
R20	470	METAL FILM RESISTOR 1/4 W 5%	430169
R21	470	METAL FILM RESISTOR 1/4 W 5%	430169
R22	100	METAL FILM RESISTOR 1/4 W 5%	430336
R23	1K	METAL FILM RESISTOR 1/4 W 5%	430170
R24	1K	METAL FILM RESISTOR 1/4 W 5%	430170
R25	100	METAL FILM RESISTOR 1/4 W 5%	430336
R26	1K5	METAL FILM RESISTOR 1/4 W 5%	430199
R27	100	METAL FILM RESISTOR 1/4 W 5%	430336
R28	1K8	METAL FILM RESISTOR 1/4 W 5%	430198
R29	100	METAL FILM RESISTOR 1/4 W 5%	430336
R30	10K	METAL FILM RESISTOR 1/4 W 5%	430339
R31	5KT	PRESET POTENTIOMETER CERMET	403052
R32	1K	METAL FILM RESISTOR 1/4 W 5%	430170
R33	10k	METAL FILM RESISTOR 1/4 W 5%	430339
R34	5KT	PRESET POTENTIOMETER CERMET	403052
R35	1K	METAL FILM RESISTOR 1/4 W 5%	430170
R36	11K/1%	PRECISION RESISTOR 1% 0.6W	430467
R37	1K	METAL FILM RESISTOR 1/4 W 5%	430170
R38	11K/1%	PRECISION RESISTOR 1% 0.6W	430467
R39	1K	METAL FILM RESISTOR 1/4 W 5%	430170
R40	3K/1%	PRECISION RESISTOR 1% 0.6W	430459
R41	3K/1%	PRECISION RESISTOR 1% 0.6W	430459
R42	3K/1%	PRECISION RESISTOR 1% 0.6W	430459
R43	1K	METAL FILM RESISTOR 1/4 W 5%	430170
R44	560	METAL FILM RESISTOR 1/4 W 5%	430178
R45	5KT	PRESET POTENTIOMETER CERMET	403052
R46	820	METAL FILM RESISTOR 1/4 W 5%	430200
R47	3K/1%	PRECISION RESISTOR 1% 0.6W	430459
R48	3K/1%	PRECISION RESISTOR 1% 0.6W	430459
R49	1K	METAL FILM RESISTOR 1/4 W 5%	430170
R50	470	METAL FILM RESISTOR 1/4 W 5%	430169
R51	100	METAL FILM RESISTOR 1/4 W 5%	430336
R52	10K	METAL FILM RESISTOR 1/4 W 5%	430339
R53	10K	METAL FILM RESISTOR 1/4 W 5%	430339
R54	1K8	METAL FILM RESISTOR 1/4 W 5%	430198
R55	1K	METAL FILM RESISTOR 1/4 W 5%	430170
R56	1K5	METAL FILM RESISTOR 1/4 W 5%	430199
R57	1K5	METAL FILM RESISTOR 1/4 W 5%	430199
R58	1K	METAL FILM RESISTOR 1/4 W 5%	430170
R59	0/0	0 OHM RESISTOR	430446

Reference	Part Type	Description	alsa code
R60	220	METAL FILM RESISTOR 1/4 W 5%	430358
R61	220	METAL FILM RESISTOR 1/4 W 5%	430358
R62	220	METAL FILM RESISTOR 1/4 W 5%	430358
R63	220	METAL FILM RESISTOR 1/4 W 5%	430358
R64	80/1%	PRECISION RESISTOR 1% 0.6W	430460
R65	3K/1%	PRECISION RESISTOR 1% 0.6W	430459
R66	39	METAL FILM RESISTOR 1/4 W 5%	430414
R67	22	METAL FILM RESISTOR 1/4 W 5%	430447
R68	100T	PRESET POTENTIOMETER CERMET	403029
R69	5K/1%	PRECISION RESISTOR 1% 0.6W	430490
R70	5KT	PRESET POTENTIOMETER CERMET	403052
R71	8K/1%	PRECISION RESISTOR 1% 0.6W	430469
R72	1K	METAL FILM RESISTOR 1/4 W 5%	430170
R73	1K	METAL FILM RESISTOR 1/4 W 5%	430170
C1	47u/E/35V	VERTICAL ELECTROLYTIC CAPACITOR	400237
C2	10u/T/35V	TANTALUM ELECTROLYTIC CAPACITOR	400134
C3	10u/T/35V	TANTALUM ELECTROLYTIC CAPACITOR	400134
C4	100n	CERAMIC CAPACITOR	400139
C5	1u/T/35V	TANTALUM ELECTROLYTIC CAPACITOR	400173
C6	100n	CERAMIC CAPACITOR	400139
C7	10u/T/35V	TANTALUM ELECTROLYTIC CAPACITOR	400134
C8	22p/C	CERAMIC CAPACITOR	400290
C9	22p/C	CERAMIC CAPACITOR	400290
C10	100n	CERAMIC CAPACITOR	400139
C11	100n	CERAMIC CAPACITOR	400139
C12	100n	CERAMIC CAPACITOR	400139
C13	100n	CERAMIC CAPACITOR	400139
C14	100n	CERAMIC CAPACITOR	400139
C15	100n	CERAMIC CAPACITOR	400139
C16	100n	CERAMIC CAPACITOR	400139
C17	100n	CERAMIC CAPACITOR	400139
C18	100n	CERAMIC CAPACITOR	400139
C19	100n	CERAMIC CAPACITOR	400139
C20	100n	CERAMIC CAPACITOR	400139
C21	100n	CERAMIC CAPACITOR	400139
C22	100n	CERAMIC CAPACITOR	400139
C23	100n	CERAMIC CAPACITOR	400139
C24	100n	CERAMIC CAPACITOR	400139
C25	100n	CERAMIC CAPACITOR	400139
C26	100n	CERAMIC CAPACITOR	400139
C27	10u/T/35V	TANTALUM ELECTROLYTIC CAPACITOR	400134
C28	10u/T/35V	TANTALUM ELECTROLYTIC CAPACITOR	400134
C29	100n	CERAMIC CAPACITOR	400139
C30	10n	CERAMIC CAPACITOR	400251
C31	100n	CERAMIC CAPACITOR	400139
C32	100n	CERAMIC CAPACITOR	400139
C33	47p/NPO	NPO CERAMIC CAPACITOR	400255
C34	47p/NPO	NPO CERAMIC CAPACITOR	400255
D1	NU	NOT USED	-----
D2	1N4148	DIODE	420010
D3	5V6/5W	ZENER DIODE 5.6V/5W (1N5339)	420088
D4	5V6/5W	ZENER DIODE 5.6V/5W (1N5339)	420088
D5	1N4148	DIODE	420010
Q1	BC557	PNP TRANSISTOR	427058
L1	6uH8/800m	INDUCTOR	422007
L2	100uH/275	INDUCTOR	422006
L3	100uH/275	INDUCTOR	422006
U1	MB3773	WATCH-DOG TIMER	482088
U2	80C552/24	24 MHZ MICROCONTROLLER	482096
U3	74HC373	74HC373	482066
U4	27256_400	256K EPROM FOR 400 MCDS	713922
U5	74HCT4040	74HCT4040	482098
U6	4X3_V3	GAL 16V8	713915

Reference	Part Type	Description	alsa code
U7	LM431	VOLTAGE REGULATOR	482078
U8	MAX518	D/A II_CBUS CONVERTER	482090
XT1	24MHZ/HC	QUARTZ CRYSTAL 24 MHZ	252009
J1	399028	FASTON CONNECTOR P.C.B.	399028
J2	CONN_21P	21 POLES FEMALE CONNECTOR	384047
J3	PAD_CI	PAD	-----
J4	PAD_CI	PAD	-----
J5	PAD_CI	PAD	-----
J6	PAD_CI	PAD	-----
J7	PICO_4	4 POLES PICOFLEX CONN. MALE P.C.B.	384042
J8	PICO_4	4 POLES PICOFLEX CONN. MALE P.C.B.	384042
J9	PAD_CI	PAD	-----
J10	PAD_CI	PAD	-----
J11	PICO_26	26 POLES PICOFLEX CONN. MALE P.C.B.	384044
J12	PICO_14	14 POLES PICOFLEX CONN. MALE P.C.B.	384040
J13	PICO_6	6 POLES PICOFLEX CONN. MALE P.C.B.	384048

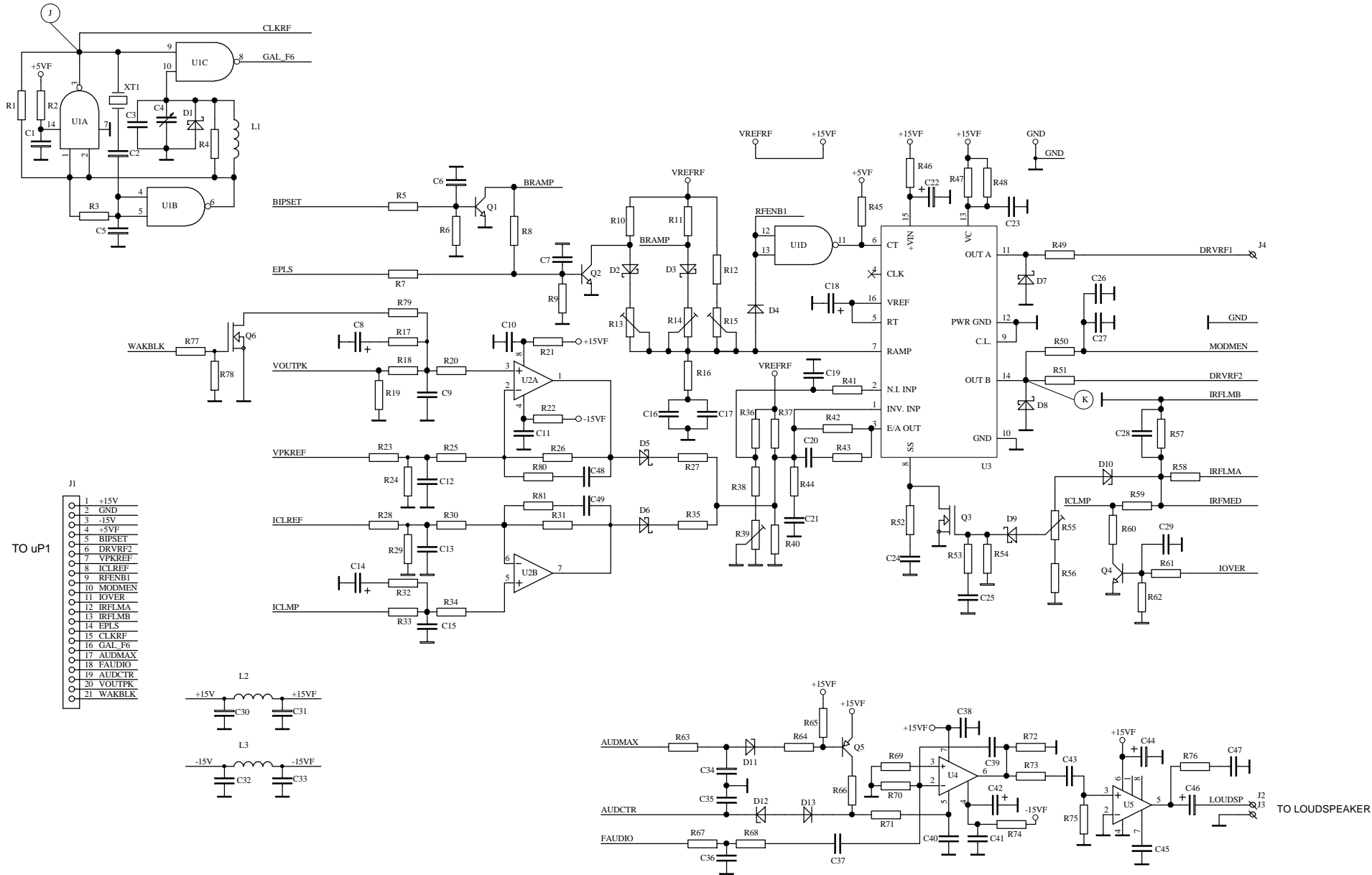

alsa apparecchi medicali s.r.l.		
EXCELL mod. MCDS		
BIS 095H - DRIVER RF		
Cod. alsa: 801304	Rev: 4.1B	22/MAR/99
Drawn by:	Approval:	



ELECTROSURGICAL UNIT EXCELL 400 MCDS**RF DRIVER BOARD****alsa code: 801304 Rev.: 4.2****Last revised: 22-mar-99 Date: 12-gen-00 13.25**

Reference	Part Type	Description	alsa code
R1	1K8	METAL FILM RESISTOR 1/4 W 5%	430198
R2	100	METAL FILM RESISTOR 1/4 W 5%	430336
R3	1K8	METAL FILM RESISTOR 1/4 W 5%	430198
R4	1K8	METAL FILM RESISTOR 1/4 W 5%	430198
R5	47K	METAL FILM RESISTOR 1/4 W 5%	430218
R6	22K	METAL FILM RESISTOR 1/4 W 5%	430179
R7	47K	METAL FILM RESISTOR 1/4 W 5%	430218
R8	100K	METAL FILM RESISTOR 1/4 W 5%	430177
R9	47K	METAL FILM RESISTOR 1/4 W 5%	430218
R10	3K9	METAL FILM RESISTOR 1/4 W 5%	430350
R11	3K9	METAL FILM RESISTOR 1/4 W 5%	430350
R12	3K9	METAL FILM RESISTOR 1/4 W 5%	430350
R13	10KT	PRESET POTENTIOMETER CERMET	403066
R14	10KT	PRESET POTENTIOMETER CERMET	403066
R15	10KT	PRESET POTENTIOMETER CERMET	403066
R16	47	METAL FILM RESISTOR 1/4 W 5%	430334
R17	1K	METAL FILM RESISTOR 1/4 W 5%	430170
R18	10K	METAL FILM RESISTOR 1/4 W 5%	430339
R19	3K/1%	PRECISION RESISTOR 1% 0.6W	430459
R20	10K	METAL FILM RESISTOR 1/4 W 5%	430339
R21	47	METAL FILM RESISTOR 1/4 W 5%	430334
R22	47	METAL FILM RESISTOR 1/4 W 5%	430334
R23	10K	METAL FILM RESISTOR 1/4 W 5%	430339
R24	11K/1%	PRECISION RESISTOR 1% 0.6W	430467
R25	10K	METAL FILM RESISTOR 1/4 W 5%	430339
R26	470K	METAL FILM RESISTOR 1/4 W 5%	430455
R27	47K	METAL FILM RESISTOR 1/4 W 5%	430218
R28	10K	METAL FILM RESISTOR 1/4 W 5%	430339
R29	3K/1%	PRECISION RESISTOR 1% 0.6W	430459
R30	10K	METAL FILM RESISTOR 1/4 W 5%	430339
R31	150K	METAL FILM RESISTOR 1/4 W 5%	430360
R32	1K	METAL FILM RESISTOR 1/4 W 5%	430170
R33	10K	METAL FILM RESISTOR 1/4 W 5%	430339
R34	10K	METAL FILM RESISTOR 1/4 W 5%	430339
R35	5K6	METAL FILM RESISTOR 1/4 W 5%	430344
R36	11K/1%	PRECISION RESISTOR 1% 0.6W	430467
R37	33K2/1%	PRECISION RESISTOR 1% 0.6W	430472
R38	1K	METAL FILM RESISTOR 1/4 W 5%	430170
R39	5KT	PRESET POTENTIOMETER CERMET	403052
R40	11K/1%	PRECISION RESISTOR 1% 0.6W	430467
R41	10K	METAL FILM RESISTOR 1/4 W 5%	430339
R42	56K	METAL FILM RESISTOR 1/4 W 5%	430176
R43	560	METAL FILM RESISTOR 1/4 W 5%	430178
R44	12	METAL FILM RESISTOR 1/4 W 5%	430415
R45	1K8	METAL FILM RESISTOR 1/4 W 5%	430198
R46	10	METAL FILM RESISTOR 1/4 W 5%	430180
R47	22	METAL FILM RESISTOR 1/4 W 5%	430447
R48	22	METAL FILM RESISTOR 1/4 W 5%	430447
R49	47	METAL FILM RESISTOR 1/4 W 5%	430334
R50	2K2	METAL FILM RESISTOR 1/4 W 5%	430343
R51	47	METAL FILM RESISTOR 1/4 W 5%	430334
R52	1K	METAL FILM RESISTOR 1/4 W 5%	430170
R53	NU	NOT USED	-----
R54	NU	NOT USED	-----
R55	NU	NOT USED	-----
R56	NU	NOT USED	-----
R57	1K	METAL FILM RESISTOR 1/4 W 5%	430170
R58	220	METAL FILM RESISTOR 1/4 W 5%	430358

Reference	Part Type	Description	alsa code
R59	100	METAL FILM RESISTOR 1/4 W 5%	430336
R60	470	METAL FILM RESISTOR 1/4 W 5%	430169
R61	10K	METAL FILM RESISTOR 1/4 W 5%	430339
R62	4K7	METAL FILM RESISTOR 1/4 W 5%	430167
R63	1K	METAL FILM RESISTOR 1/4 W 5%	430170
R64	2K2	METAL FILM RESISTOR 1/4 W 5%	430343
R65	10K	METAL FILM RESISTOR 1/4 W 5%	430339
R66	10K	METAL FILM RESISTOR 1/4 W 5%	430339
R67	22K	METAL FILM RESISTOR 1/4 W 5%	430179
R68	22K	METAL FILM RESISTOR 1/4 W 5%	430179
R69	1K	METAL FILM RESISTOR 1/4 W 5%	430170
R70	1K	METAL FILM RESISTOR 1/4 W 5%	430170
R71	100K	METAL FILM RESISTOR 1/4 W 5%	430177
R72	100K	METAL FILM RESISTOR 1/4 W 5%	430177
R73	22K	METAL FILM RESISTOR 1/4 W 5%	430179
R74	220	METAL FILM RESISTOR 1/4 W 5%	430358
R75	15K	METAL FILM RESISTOR 1/4 W 5%	430345
R76	10	METAL FILM RESISTOR 1/4 W 5%	430180
R77	100	METAL FILM RESISTOR 1/4 W 5%	430336
R78	1K	METAL FILM RESISTOR 1/4 W 5%	430170
R79	100	METAL FILM RESISTOR 1/4 W 5%	430336
R80	1K	METAL FILM RESISTOR 1/4 W 5%	430170
R81	NU	NOT USED	-----
C1	100n	CERAMIC CAPACITOR	400139
C2	100p/NPO	NPO CERAMIC CAPACITOR	400260
C3	12p/C	CERAMIC CAPACITOR	400269
C4	7_100p	TRIMMING CAPACITOR 7/100P	400289
C5	470p/C	CERAMIC CAPACITOR	400242
C6	100n	CERAMIC CAPACITOR	400139
C7	100n	CERAMIC CAPACITOR	400139
C8	1u/T/35V	TANTALUM ELECTROLYTIC CAPACITOR	400173
C9	10n	CERAMIC CAPACITOR	400251
C10	100n	CERAMIC CAPACITOR	400139
C11	100n	CERAMIC CAPACITOR	400139
C12	100n	CERAMIC CAPACITOR	400139
C13	100n	CERAMIC CAPACITOR	400139
C14	1u/T/35V	TANTALUM ELECTROLYTIC CAPACITOR	400173
C15	10n	CERAMIC CAPACITOR	400251
C16	220p/P/400V	METALLIZED POLYESTER CAPACITOR	400280
C17	220p/P/400V	METALLIZED POLYESTER CAPACITOR	400280
C18	10u/T/35V	TANTALUM ELECTROLYTIC CAPACITOR	400134
C19	100n	CERAMIC CAPACITOR	400139
C20	100n	CERAMIC CAPACITOR	400139
C21	100n	CERAMIC CAPACITOR	400139
C22	10u/T/35V	TANTALUM ELECTROLYTIC CAPACITOR	400134
C23	100n	CERAMIC CAPACITOR	400139
C24	10n	CERAMIC CAPACITOR	400251
C25	NU	NOT USED	-----
C26	220n/P	METALLIZED FILM CAPACITOR	400271
C27	10n	CERAMIC CAPACITOR	400251
C28	1n/P	METALLIZED POLYESTER CAPACITOR	400278
C29	10n	CERAMIC CAPACITOR	400251
C30	100n	CERAMIC CAPACITOR	400139
C31	100n	CERAMIC CAPACITOR	400139
C32	100n	CERAMIC CAPACITOR	400139
C33	100n	CERAMIC CAPACITOR	400139
C34	100n	CERAMIC CAPACITOR	400139
C35	100n	CERAMIC CAPACITOR	400139
C36	100n	CERAMIC CAPACITOR	400139
C37	100n	CERAMIC CAPACITOR	400139
C38	100n	CERAMIC CAPACITOR	400139
C39	2n2/C	CERAMIC CAPACITOR	400261

Reference	Part Type	Description	alsa code
C40	100n	CERAMIC CAPACITOR	400139
C41	100n	CERAMIC CAPACITOR	400139
C42	10u/T/35V	TANTALUM ELECTROLYTIC CAPACITOR	400134
C43	100n	CERAMIC CAPACITOR	400139
C44	10u/T/35V	TANTALUM ELECTROLYTIC CAPACITOR	400134
C45	10n	CERAMIC CAPACITOR	400251
C46	47u/E/35V	VERTICAL ELECTROLYTIC CAPACITOR	400237
C47	100n	CERAMIC CAPACITOR	400139
C48	10n	CERAMIC CAPACITOR	400251
C49	NU	NOT USED	-----
D1	BAT83	SCHOTTKY DIODE	420070
D2	BAT83	SCHOTTKY DIODE	420070
D3	BAT83	SCHOTTKY DIODE	420070
D4	1N4148	DIODE	420010
D5	BAT83	SCHOTTKY DIODE	420070
D6	BAT83	SCHOTTKY DIODE	420070
D7	11DQ06	SCHOTTKY DIODE	420054
D8	11DQ06	SCHOTTKY DIODE	420054
D9	NU	NOT USED	-----
D10	NU	NOT USED	-----
D11	10V/0.5W	ZENER DIODE 10V-1/2W	420068
D12	4V7/0.5W	ZENER DIODE 4V7-1/2W	420066
D13	1N4148	DIODE	420010
Q1	BC237B	NPN TRANSISTOR	427057
Q2	BC237B	NPN TRANSISTOR	427057
Q3	NU	NOT USED	-----
Q4	BC237B	NPN TRANSISTOR	427057
Q5	BC307B	PNP TRANSISTOR	427058
Q6	VN10KM	N CHANNEL MOSFET	427054
L1	150uH/175mA	INDUCTOR	422008
L2	6UH8/800MA	INDUCTOR	422007
L3	6UH8/800MA	INDUCTOR	422007
U1	74HCT00	HCT 7400	482049
U2	TL072	OP.AMP. TL072	482019
U3	UC3825	PWM UC3825	482064
U4	CA3080	OTA CA3080E	482055
U5	LM386	BF LM386	482056
XT1	950kHz/C	CERAMIC RESONATOR	252002
J1	CONN_21PM	21 POLES MALE CONNECTOR	384046
J2	PAD_CI	PAD	-----
J3	PAD_CI	PAD	-----
J4	PAD_CI	PAD	-----

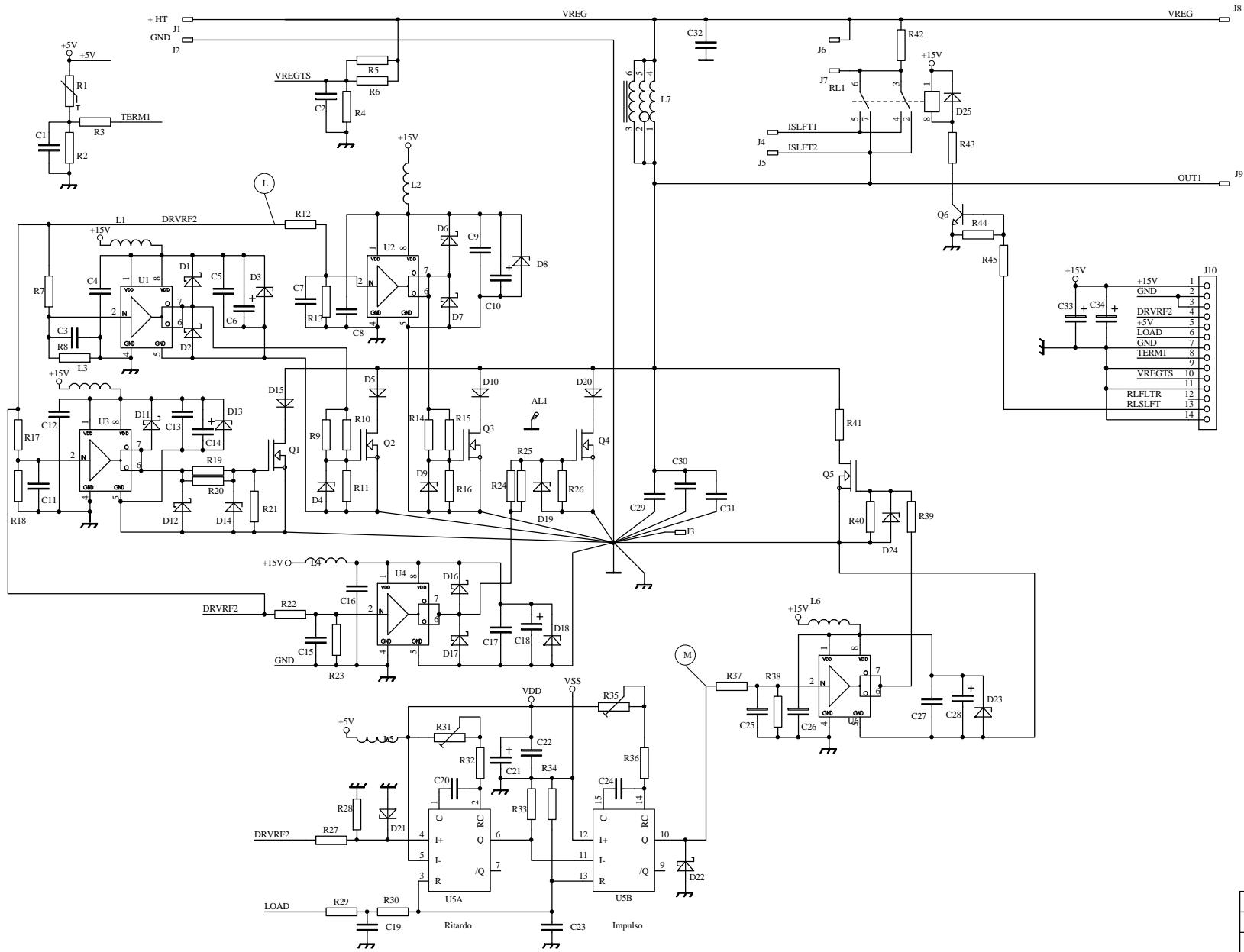

alsa apparecchi medicali s.r.l.		
EXCELL 400 MCDS		
BIS_O95D - RF Power Board		
alsacode: 801305	Rev: 4.1	29/MAR/99
Drawn by:		Approval:



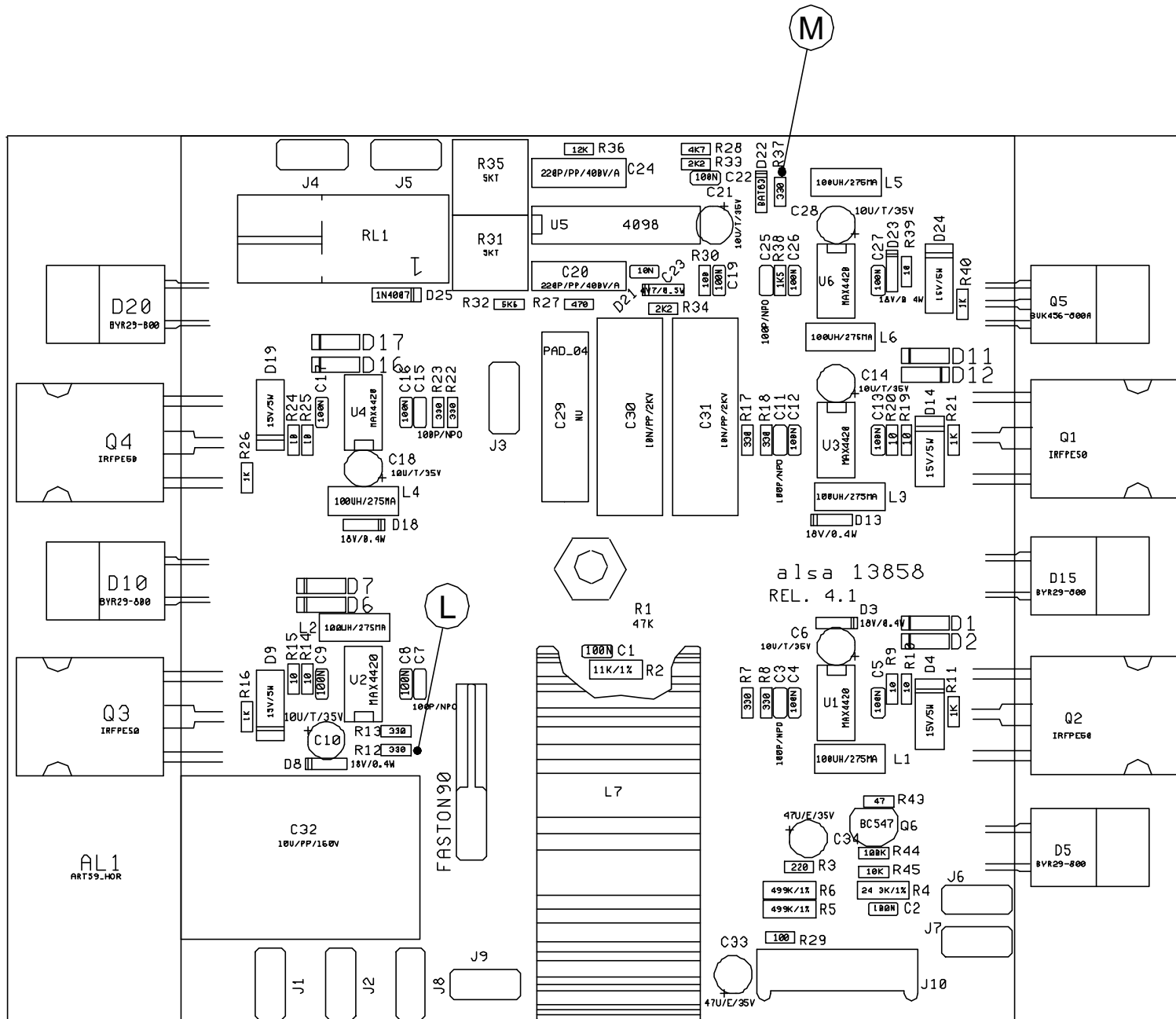

ELECTROSURGICAL UNIT EXCELL 400 MCDS**R.F. POWER BOARD****also code: 801305 Rev.: 4.1****Last revised: 29-mar-99 Date: 12-gen-00 13.26**

Reference	Part Type	Description	also code
R1	NTC_V47K	NTC THERMISTOR THREADED 47K 5%	430452
R2	11K/1%	PRECISION RESISTOR 1% 0.6W	430467
R3	220	METAL FILM RESISTOR 1/4 W 5%	430358
R4	24K3/1%	PRECISION RESISTOR 1% 0.6W	430488
R5	499k/1%	PRECISION RESISTOR 1% 0.6W	430466
R6	499k/1%	PRECISION RESISTOR 1% 0.6W	430466
R7	330	METAL FILM RESISTOR 1/4 W 5%	430171
R8	330	METAL FILM RESISTOR 1/4 W 5%	430171
R9	10	METAL FILM RESISTOR 1/4 W 5%	430180
R10	10	METAL FILM RESISTOR 1/4 W 5%	430180
R11	1K	METAL FILM RESISTOR 1/4 W 5%	430170
R12	330	METAL FILM RESISTOR 1/4 W 5%	430171
R13	330	METAL FILM RESISTOR 1/4 W 5%	430171
R14	10	METAL FILM RESISTOR 1/4 W 5%	430180
R15	10	METAL FILM RESISTOR 1/4 W 5%	430180
R16	1K	METAL FILM RESISTOR 1/4 W 5%	430170
R17	330	METAL FILM RESISTOR 1/4 W 5%	430171
R18	330	METAL FILM RESISTOR 1/4 W 5%	430171
R19	10	METAL FILM RESISTOR 1/4 W 5%	430180
R20	10	METAL FILM RESISTOR 1/4 W 5%	430180
R21	1K	METAL FILM RESISTOR 1/4 W 5%	430170
R22	330	METAL FILM RESISTOR 1/4 W 5%	430171
R23	330	METAL FILM RESISTOR 1/4 W 5%	430171
R24	10	METAL FILM RESISTOR 1/4 W 5%	430180
R25	10	METAL FILM RESISTOR 1/4 W 5%	430180
R26	1K	METAL FILM RESISTOR 1/4 W 5%	430170
R27	470	METAL FILM RESISTOR 1/4 W 5%	430169
R28	4K7	METAL FILM RESISTOR 1/4 W 5%	430167
R29	100	METAL FILM RESISTOR 1/4 W 5%	430336
R30	100	METAL FILM RESISTOR 1/4 W 5%	430336
R31	5KT	PRESET POTENTIOMETER CERMET	403052
R32	5K6	METAL FILM RESISTOR 1/4 W 5%	430344
R33	2K2	METAL FILM RESISTOR 1/4 W 5%	430343
R34	2K2	METAL FILM RESISTOR 1/4 W 5%	430343
R35	5KT	PRESET POTENTIOMETER CERMET	403052
R36	12K	METAL FILM RESISTOR 1/4 W 5%	430351
R37	330	METAL FILM RESISTOR 1/4 W 5%	430171
R38	1K5	METAL FILM RESISTOR 1/4 W 5%	430199
R39	10	METAL FILM RESISTOR 1/4 W 5%	430180
R40	1K	METAL FILM RESISTOR 1/4 W 5%	430170
R41	50/50W/F	WIREWOUND RESISTOR 50 W	430487
R42	150/50W/F	NON INDUCTIVE RESISTOR 50 W	430486
R43	47	METAL FILM RESISTOR 1/4 W 5%	430334
R44	100K	METAL FILM RESISTOR 1/4 W 5%	430177
R45	10K	METAL FILM RESISTOR 1/4 W 5%	430339
C1	100n	CERAMIC CAPACITOR	400139
C2	100n	CERAMIC CAPACITOR	400139
C3	100p/NPO	NPO CERAMIC CAPACITOR	400260
C4	100n	CERAMIC CAPACITOR	400139
C5	100n	CERAMIC CAPACITOR	400139
C6	10u/T/35V	TANTALUM ELECTROLYTIC CAPACITOR	400134
C7	100p/NPO	NPO CERAMIC CAPACITOR	400260
C8	100n	CERAMIC CAPACITOR	400139
C9	100n	CERAMIC CAPACITOR	400139
C10	10u/T/35V	TANTALUM ELECTROLYTIC CAPACITOR	400134
C11	100p/NPO	NPO CERAMIC CAPACITOR	400260
C12	100n	CERAMIC CAPACITOR	400139
C13	100n	CERAMIC CAPACITOR	400139
C14	10u/T/35V	TANTALUM ELECTROLYTIC CAPACITOR	400134

Reference	Part Type	Description	alsa code
C15	100p/NPO	NPO CERAMIC CAPACITOR	400260
C16	100n	CERAMIC CAPACITOR	400139
C17	100n	CERAMIC CAPACITOR	400139
C18	10u/T/35V	TANTALUM ELECTROLYTIC CAPACITOR	400134
C19	100n	CERAMIC CAPACITOR	400139
C20	220p/P/400V	METALLIZED POLYESTER CAPACITOR	400280
C21	10u/T/35V	TANTALUM ELECTROLYTIC CAPACITOR	400134
C22	100n	CERAMIC CAPACITOR	400139
C23	10n	CERAMIC CAPACITOR	400251
C24	220p/P/400V	METALLIZED POLYESTER CAPACITOR	400280
C25	100p/NPO	NPO CERAMIC CAPACITOR	400260
C26	100n	CERAMIC CAPACITOR	400139
C27	100n	CERAMIC CAPACITOR	400139
C28	10u/T/35V	TANTALUM ELECTROLYTIC CAPACITOR	400134
C29	NU	NOT USED	-----
C30	10n/PP/2KV	POLYPROPYLENE CAPACITOR	400236
C31	10n/PP/2KV	POLYPROPYLENE CAPACITOR	400236
C32	10u/PP/160V	POLYPROPYLENE CAPACITOR	400308
C33	47u/E/35V	VERTICAL ELECTROLYTIC CAPACITOR	400237
C34	47u/E/35V	VERTICAL ELECTROLYTIC CAPACITOR	400237
D1	11DQ06	SCHOTTKY DIODE	420054
D2	11DQ06	SCHOTTKY DIODE	420054
D3	18V/0.5W	ZENER DIODE 18V/0.5W	420090
D4	15V/5W	ZENER DIODE 15V/5W (1N5352)	420094
D5	BYR29-800	ULTRA FAST DIODE	420095
D6	11DQ06	SCHOTTKY DIODE	420054
D7	11DQ06	SCHOTTKY DIODE	420054
D8	18V/0.5W	ZENER DIODE 18V/0.5W	420090
D9	15V/5W	ZENER DIODE 15V/5W (1N5352)	420094
D10	BYR29-800	ULTRA FAST DIODE	420095
D11	11DQ06	SCHOTTKY DIODE	420054
D12	11DQ06	SCHOTTKY DIODE	420054
D13	18V/0.5W	ZENER DIODE 18V/0.5W	420090
D14	15V/5W	ZENER DIODE 15V/5W (1N5352)	420094
D15	BYR29-800	ULTRA FAST DIODE	420095
D16	11DQ06	SCHOTTKY DIODE	420054
D17	11DQ06	SCHOTTKY DIODE	420054
D18	18V/0.5W	ZENER DIODE 18V/0.5W	420090
D19	15V/5W	ZENER DIODE 15V/5W (1N5352)	420094
D20	BYR29-800	ULTRA FAST DIODE	420095
D21	4V7/0.5W	ZENER DIODE 4V7-1/2W	420066
D22	BAT83	SCHOTTKY DIODE	420070
D23	18V/0.5W	ZENER DIODE 18V/0.5W	420090
D24	15V/5W	ZENER DIODE 15V/5W (1N5352)	420094
D25	1N4007	DIODE	420001
Q1	IRFPE50	N CHANNEL MOSFET	427087
Q2	IRFPE50	N CHANNEL MOSFET	427087
Q3	IRFPE50	N CHANNEL MOSFET	427087
Q4	IRFPE50	N CHANNEL MOSFET	427087
Q5	BUK456-800	N CHANNEL MOSFET	427088
Q6	BC547	NPN TRANSISTOR	427057
L1	100uH/275mA	INDUCTOR	422006
L2	100uH/275mA	INDUCTOR	422006
L3	100uH/275mA	INDUCTOR	422006
L4	100uH/275mA	INDUCTOR	422006
L5	100uH/275mA	INDUCTOR	422006
L6	100uH/275mA	INDUCTOR	422006
L7	IND_3W	RESONANT INDUCTOR (R.F. STAGE)	713907
U1	MAX4420	MOSFET DRIVER	482093
U2	MAX4420	MOSFET DRIVER	482093
U3	MAX4420	MOSFET DRIVER	482093
U4	MAX4420	MOSFET DRIVER	482093
U5	4098	CMOS CD4098	482038

Reference	Part Type	Description	alsa code
U6	MAX4420	MOSFET DRIVER	482093
RL1	40.52-12VDC	RELAY OMRON	404040
J1	399028	FASTON CONNECTOR P.C.B.	399028
J2	399028	FASTON CONNECTOR P.C.B.	399028
J3	399028	FASTON CONNECTOR P.C.B.	399028
J4	399028	FASTON CONNECTOR P.C.B.	399028
J5	399028	FASTON CONNECTOR P.C.B.	399028
J6	399028	FASTON CONNECTOR P.C.B.	399028
J7	399028	FASTON CONNECTOR P.C.B.	399028
J8	399028	FASTON CONNECTOR P.C.B.	399028
J9	399028	FASTON CONNECTOR P.C.B.	399028
J10	PICO_14	14 POLES PICO FLEX CONN. MALE P.C.B.	384040
AL1	ART_59_HOR	ALUMINIUM HEAT SINK	713884

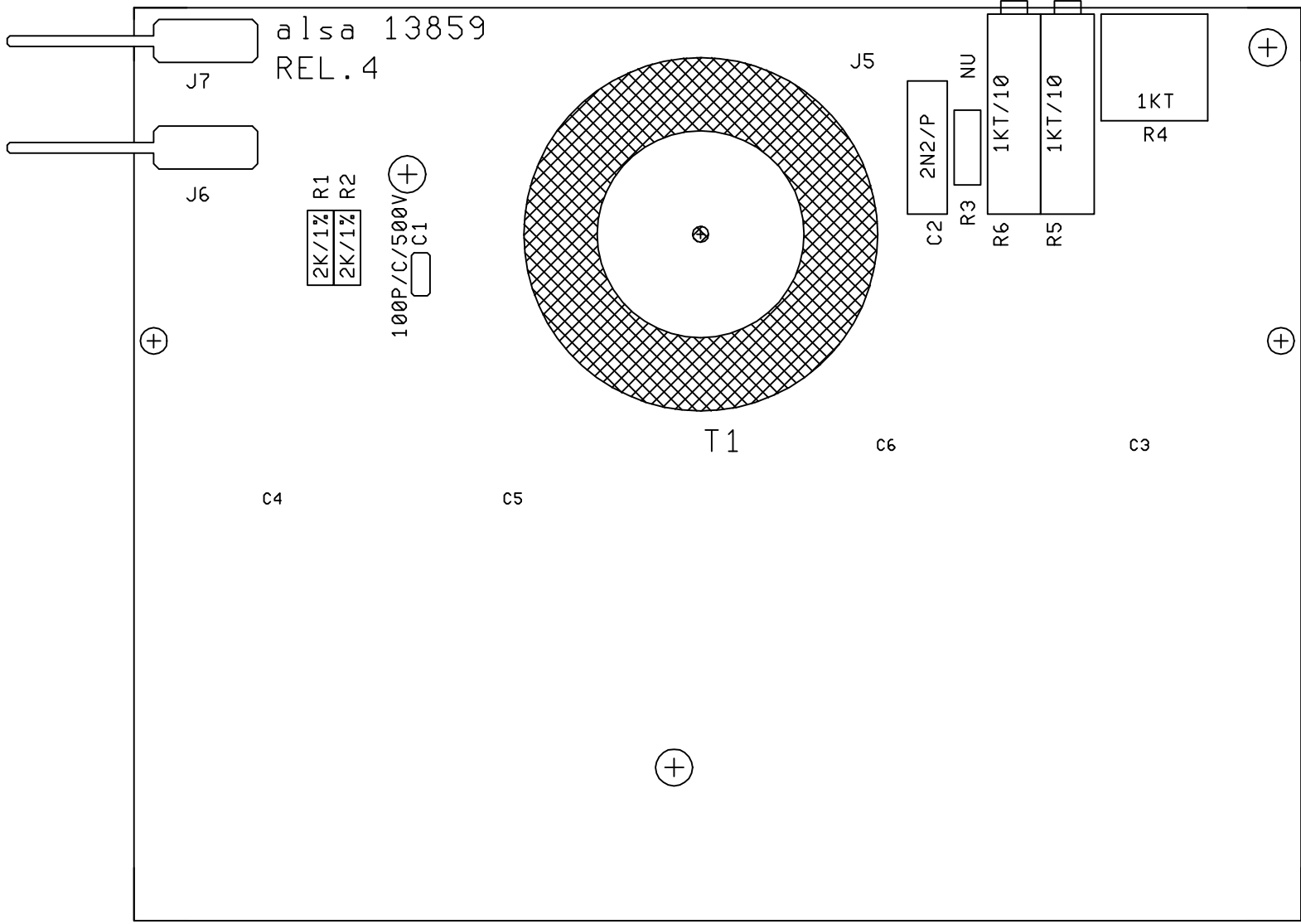

ELECTROSURGICAL UNIT EXCELL 400 MCDS**POWER READER BOARD (1)****alsa code: 801306 Rev.: 4.1****Last revised: 29-mar-99 Date: 12-gen-00 13.26**

Reference	Part Type	Description	alsa code
R1	2K/1%	PRECISION RESISTOR 1% 0.6W	430461
R2	2K/1%	PRECISION RESISTOR 1% 0.6W	430461
R3	NU	NOT USED	-----
R4	1KT	PRESET POTENTIOMETER CERMET	403063
R5	1KT/10	PRESET POTENTIOMETER MULTITURN	403108
R6	1KT/10	PRESET POTENTIOMETER MULTITURN	403108
C1	100p/C/500V	CERAMIC CAPACITOR	400293
C2	2n2/P	METALLIZED POLYESTER CAPACITOR	400277
C3	3p/CSTP	CAPACITOR REALIZED ON PCB	-----
C4	3p/CSTP	CAPACITOR REALIZED ON PCB	-----
C5	3p/CSTP	CAPACITOR REALIZED ON PCB	-----
C6	3p/CSTP	CAPACITOR REALIZED ON PCB	-----
T1	TRANS CURRE	OUTPUT CURRENT TRANSFORMER	713908
J1	PAND_3PF	3 POLES PCB CONNECTOR PANDUIT FEMALE 90°	384037
J2	PAND_3PF	3 POLES PCB CONNECTOR PANDUIT FEMALE 90°	384037
J3	PAND_3PF	3 POLES PCB CONNECTOR PANDUIT FEMALE 90°	384037
J4	PAND_3PF	3 POLES PCB CONNECTOR PANDUIT FEMALE 90°	384037
J5	CONN_5PM	5 POLES MALE CONNECTOR	384050
J6	399029	FASTON CONNECTOR P.C.B 90°	399029
J7	399029	FASTON CONNECTOR P.C.B 90°	399029

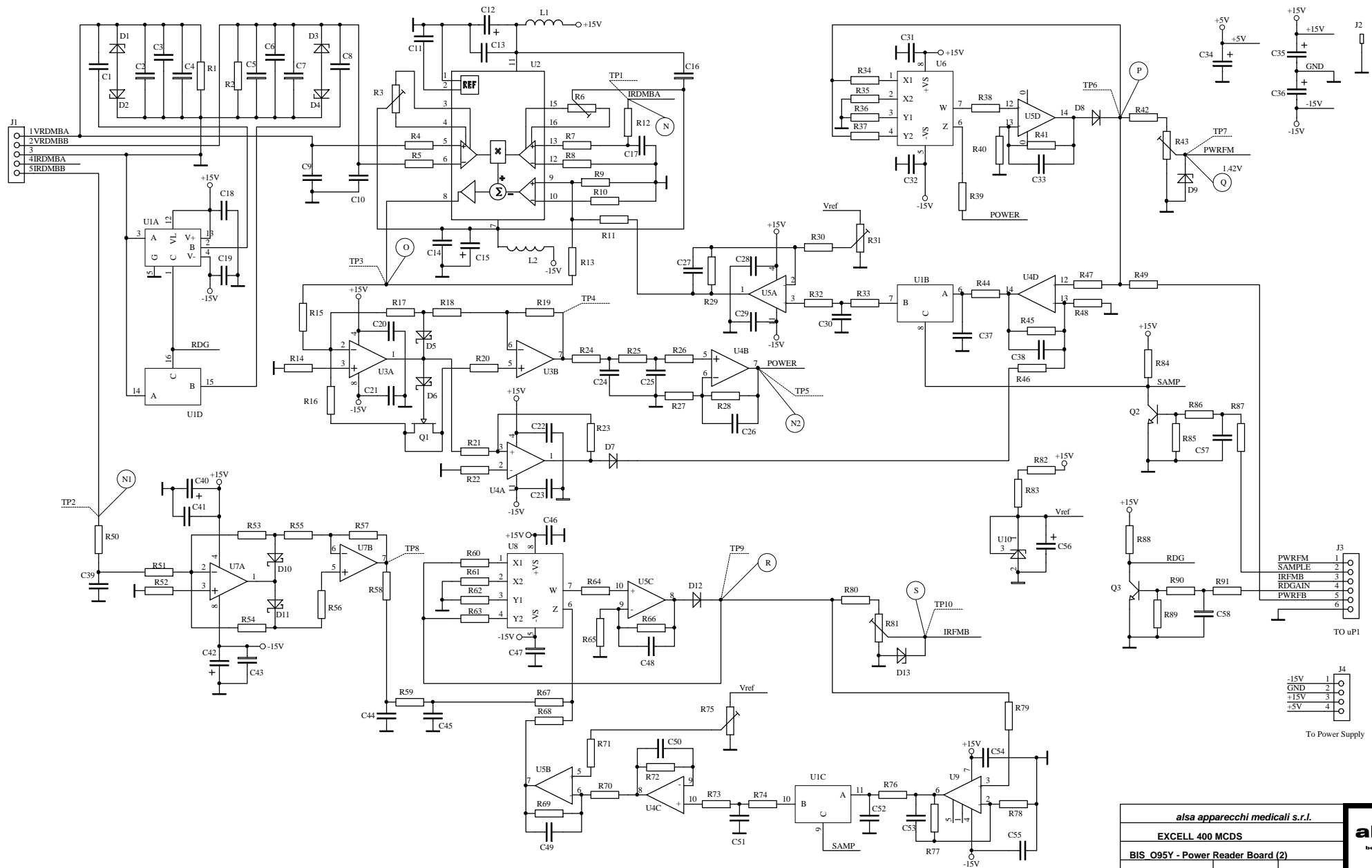

alsa apparecchi medicali s.r.l.		alsa bologna
EXCELL 400 MCDS		
BIS O95Y - Power Reader Board (2)		
alsa code: 801307	Rev: 4.2	
Drawn by:	Approval:	

ELECTROSURGICAL UNIT EXCELL 400 MCDS**POWER READ BOARD (2)****alsa code: 801307 Rev.: 4.2****Last revised: 29-mar-99 Date: 12-gen-00 13.26**

Reference	Part Type	Description	alsa code
R1	10K	METAL FILM RESISTOR 1/4 W 5%	430339
R2	10K	METAL FILM RESISTOR 1/4 W 5%	430339
R3	20KT/10	PRESET POTENTIOMETER MULTITURN	403102
R4	1K/1%	PRECISION RESISTOR 1% 0.6W	430458
R5	1K/1%	PRECISION RESISTOR 1% 0.6W	430458
R6	20KT/10	PRESET POTENTIOMETER MULTITURN	403102
R7	1K/1%	PRECISION RESISTOR 1% 0.6W	430458
R8	1K/1%	PRECISION RESISTOR 1% 0.6W	430458
R9	200/1%	PRECISION RESISTOR 1% 0.6W	430481
R10	200/1%	PRECISION RESISTOR 1% 0.6W	430481
R11	11K/1%	PRECISION RESISTOR 1% 0.6W	430467
R12	10	METAL FILM RESISTOR 1/4 W 5%	430180
R13	1K/1%	PRECISION RESISTOR 1% 0.6W	430458
R14	1K	METAL FILM RESISTOR 1/4 W 5%	430170
R15	2K/1%	PRECISION RESISTOR 1% 0.6W	430461
R16	1K/1%	PRECISION RESISTOR 1% 0.6W	430458
R17	2K/1%	PRECISION RESISTOR 1% 0.6W	430461
R18	2K/1%	PRECISION RESISTOR 1% 0.6W	430461
R19	2K/1%	PRECISION RESISTOR 1% 0.6W	430461
R20	1K	METAL FILM RESISTOR 1/4 W 5%	430170
R21	1K	METAL FILM RESISTOR 1/4 W 5%	430170
R22	1K	METAL FILM RESISTOR 1/4 W 5%	430170
R23	1M	METAL FILM RESISTOR 1/4 W 5%	430331
R24	10K	METAL FILM RESISTOR 1/4 W 5%	430339
R25	10K	METAL FILM RESISTOR 1/4 W 5%	430339
R26	5K6	METAL FILM RESISTOR 1/4 W 5%	430344
R27	51K/1%	PRECISION RESISTOR 1% 0.6W	430482
R28	51K/1%	PRECISION RESISTOR 1% 0.6W	430482
R29	11K/1%	PRECISION RESISTOR 1% 0.6W	430467
R30	10K/1%	PRECISION RESISTOR 1% 0.6W	430480
R31	2KT/10	PRESET POTENTIOMETER MULTITURN	403107
R32	10K	METAL FILM RESISTOR 1/4 W 5%	430339
R33	220K	METAL FILM RESISTOR 1/4 W 5%	430352
R34	1K	METAL FILM RESISTOR 1/4 W 5%	430170
R35	1K	METAL FILM RESISTOR 1/4 W 5%	430170
R36	1K	METAL FILM RESISTOR 1/4 W 5%	430170
R37	1K	METAL FILM RESISTOR 1/4 W 5%	430170
R38	1K	METAL FILM RESISTOR 1/4 W 5%	430170
R39	10K	METAL FILM RESISTOR 1/4 W 5%	430339
R40	1K	METAL FILM RESISTOR 1/4 W 5%	430170
R41	1M	METAL FILM RESISTOR 1/4 W 5%	430331
R42	80/1%	PRECISION RESISTOR 1% 0.6W	430460
R43	1KT/10	PRESET POTENTIOMETER MULTITURN	403108
R44	3K9	METAL FILM RESISTOR 1/4 W 5%	430350
R45	5K/1%	PRECISION RESISTOR 1% 0.6W	430490
R46	1K	METAL FILM RESISTOR 1/4 W 5%	430170
R47	1K	METAL FILM RESISTOR 1/4 W 5%	430170
R48	1K/1%	PRECISION RESISTOR 1% 0.6W	430458
R49	200/1%	PRECISION RESISTOR 1% 0.6W	430481
R50	10	METAL FILM RESISTOR 1/4 W 5%	430180
R51	1K/1%	PRECISION RESISTOR 1% 0.6W	430458
R52	1K	METAL FILM RESISTOR 1/4 W 5%	430170
R53	1K/1%	PRECISION RESISTOR 1% 0.6W	430458
R54	1K/1%	PRECISION RESISTOR 1% 0.6W	430458
R55	1K/1%	PRECISION RESISTOR 1% 0.6W	430458
R56	470	METAL FILM RESISTOR 1/4 W 5%	430169
R57	1K/1%	PRECISION RESISTOR 1% 0.6W	430458
R58	10K/1%	PRECISION RESISTOR 1% 0.6W	430480

Reference	Part Type	Description	alsa code
R59	10K/1%	PRECISION RESISTOR 1% 0.6W	430480
R60	1K	METAL FILM RESISTOR 1/4 W 5%	430170
R61	1K	METAL FILM RESISTOR 1/4 W 5%	430170
R62	1K	METAL FILM RESISTOR 1/4 W 5%	430170
R63	1K	METAL FILM RESISTOR 1/4 W 5%	430170
R64	1K	METAL FILM RESISTOR 1/4 W 5%	430170
R65	1K	METAL FILM RESISTOR 1/4 W 5%	430170
R66	1M	METAL FILM RESISTOR 1/4 W 5%	430331
R67	1K/1%	PRECISION RESISTOR 1% 0.6W	430458
R68	499K/1%	PRECISION RESISTOR 1% 0.6W	430466
R69	10K/1%	PRECISION RESISTOR 1% 0.6W	430480
R70	10K/1%	PRECISION RESISTOR 1% 0.6W	430480
R71	4K7	METAL FILM RESISTOR 1/4 W 5%	430167
R72	10K	METAL FILM RESISTOR 1/4 W 5%	430339
R73	10K	METAL FILM RESISTOR 1/4 W 5%	430339
R74	220K	METAL FILM RESISTOR 1/4 W 5%	430352
R75	2KT/10	PRESET POTENTIOMETER MULTITURN	403107
R76	3K9	METAL FILM RESISTOR 1/4 W 5%	430350
R77	10K/1%	PRECISION RESISTOR 1% 0.6W	430480
R78	1K/1%	PRECISION RESISTOR 1% 0.6W	430458
R79	1K	METAL FILM RESISTOR 1/4 W 5%	430170
R80	80/1%	PRECISION RESISTOR 1% 0.6W	430460
R81	1KT/10	PRESET POTENTIOMETER MULTITURN	403108
R82	1K	METAL FILM RESISTOR 1/4 W 5%	430170
R83	2K2	METAL FILM RESISTOR 1/4 W 5%	430343
R84	10K	METAL FILM RESISTOR 1/4 W 5%	430339
R85	47K	METAL FILM RESISTOR 1/4 W 5%	430218
R86	1K	METAL FILM RESISTOR 1/4 W 5%	430170
R87	4K7	METAL FILM RESISTOR 1/4 W 5%	430167
R88	10K	METAL FILM RESISTOR 1/4 W 5%	430339
R89	47K	METAL FILM RESISTOR 1/4 W 5%	430218
R90	1K	METAL FILM RESISTOR 1/4 W 5%	430170
R91	4K7	METAL FILM RESISTOR 1/4 W 5%	430167
C1	1n/P	METALLIZED POLYESTER CAPACITOR	400278
C2	220p/P/400V	METALLIZED POLYESTER CAPACITOR	400280
C3	220p/P/400V	METALLIZED POLYESTER CAPACITOR	400280
C4	220p/P/400V	METALLIZED POLYESTER CAPACITOR	400280
C5	220p/P/400V	METALLIZED POLYESTER CAPACITOR	400280
C6	220p/P/400V	METALLIZED POLYESTER CAPACITOR	400280
C7	220p/P/400V	METALLIZED POLYESTER CAPACITOR	400280
C8	1n/P	METALLIZED POLYESTER CAPACITOR	400278
C9	12p/C	CERAMIC CAPACITOR	400269
C10	12p/C	CERAMIC CAPACITOR	400269
C11	100n	CERAMIC CAPACITOR	400139
C12	10u/T/35V	TANTALUM ELECTROLYTIC CAPACITOR	400134
C13	100n	CERAMIC CAPACITOR	400139
C14	100n	CERAMIC CAPACITOR	400139
C15	10u/T/35V	TANTALUM ELECTROLYTIC CAPACITOR	400134
C16	100n	CERAMIC CAPACITOR	400139
C17	12p/C	CERAMIC CAPACITOR	400269
C18	100n	CERAMIC CAPACITOR	400139
C19	100n	CERAMIC CAPACITOR	400139
C20	100n	CERAMIC CAPACITOR	400139
C21	100n	CERAMIC CAPACITOR	400139
C22	100n	CERAMIC CAPACITOR	400139
C23	100n	CERAMIC CAPACITOR	400139
C24	10n	CERAMIC CAPACITOR	400251
C25	22n/C	CERAMIC CAPACITOR	400132
C26	10n	CERAMIC CAPACITOR	400251
C27	10n	CERAMIC CAPACITOR	400251
C28	100n	CERAMIC CAPACITOR	400139
C29	100n	CERAMIC CAPACITOR	400139

Reference	Part Type	Description	alsa code
C30	1u/P/100V	METALLIZED FILM CAPACITOR	400154
C31	100n	CERAMIC CAPACITOR	400139
C32	100n	CERAMIC CAPACITOR	400139
C33	100n	CERAMIC CAPACITOR	400139
C34	47u/E/35V	VERTICAL ELECTROLYTIC CAPACITOR	400237
C35	47u/E/35V	VERTICAL ELECTROLYTIC CAPACITOR	400237
C36	47u/E/35V	VERTICAL ELECTROLYTIC CAPACITOR	400237
C37	10n	CERAMIC CAPACITOR	400251
C38	10n	CERAMIC CAPACITOR	400251
C39	12p/C	CERAMIC CAPACITOR	400269
C40	10u/T/35V	TANTALUM ELECTROLYTIC CAPACITOR	400134
C41	100n	CERAMIC CAPACITOR	400139
C42	10u/T/35V	TANTALUM ELECTROLYTIC CAPACITOR	400134
C43	100n	CERAMIC CAPACITOR	400139
C44	10n	CERAMIC CAPACITOR	400251
C45	22n/C	CERAMIC CAPACITOR	400132
C46	100n	CERAMIC CAPACITOR	400139
C47	100n	CERAMIC CAPACITOR	400139
C48	100n	CERAMIC CAPACITOR	400139
C49	10n	CERAMIC CAPACITOR	400251
C50	10n	CERAMIC CAPACITOR	400251
C51	1u/P/100V	METALLIZED FILM CAPACITOR	400154
C52	10n	CERAMIC CAPACITOR	400251
C53	10n	CERAMIC CAPACITOR	400251
C54	100n	CERAMIC CAPACITOR	400139
C55	100n	CERAMIC CAPACITOR	400139
C56	1u/T/35V	TANTALUM ELECTROLYTIC CAPACITOR	400173
C57	100n	CERAMIC CAPACITOR	400139
C58	100n	CERAMIC CAPACITOR	400139
D1	6V2/0.5W	ZENER DIODE 6V2/0.5W	420053
D2	6V2/0.5W	ZENER DIODE 6V2/0.5W	420053
D3	6V2/0.5W	ZENER DIODE 6V2/0.5W	420053
D4	6V2/0.5W	ZENER DIODE 6V2/0.5W	420053
D5	BAT83	SCHOTTKY DIODE	420070
D6	BAT83	SCHOTTKY DIODE	420070
D7	1N4148	DIODE	420010
D8	1N4148	DIODE	420010
D9	5V6/0.5W	ZENER DIODE 5V6/0.5W	420018
D10	BAT83	SCHOTTKY DIODE	420070
D11	BAT83	SCHOTTKY DIODE	420070
D12	1N4148	DIODE	420010
D13	5V6/0.5W	ZENER DIODE 5V6/0.5W	420018
Q1	2N3819	N CHANNEL FET	427008
Q2	BC237B	NPN TRANSISTOR	427057
Q3	BC237B	NPN TRANSISTOR	427057
L1	1mH/100mA	INDUCTOR	422005
L2	1mH/100mA	INDUCTOR	422005
U1	MAX365	ANALOG SWITCH	482091
U2	HA325569	ANALOG MULTIPLIER	482092
U3	LM6182	OP.AMP. LM6182	482095
U4	TL084	OP.AMP. TL084	482043
U5	TL084	OP.AMP. TL084	482043
U6	AD633	ANALOG MULTIPLIER	482084
U7	LM6182	OP.AMP. LM6182	482095
U8	AD633	ANALOG MULTIPLIER	482084
U9	TL071	OP.AMP. TL071	482018
U10	LM431	VOLTAGE REGULATOR	482078
J1	CONN_5PF	5 POLES FEMALE CONNECTOR	384051
J2	PAD_04	COMPONENT NOT FOUND	-----
J3	PICO_6	6 POLES PICOFLEX CONN. MALE P.C.B.	384048
J4	PICO_4	4 POLES PICOFLEX CONN. MALE P.C.B.	384042

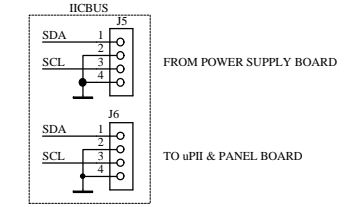
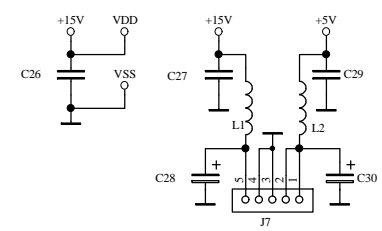
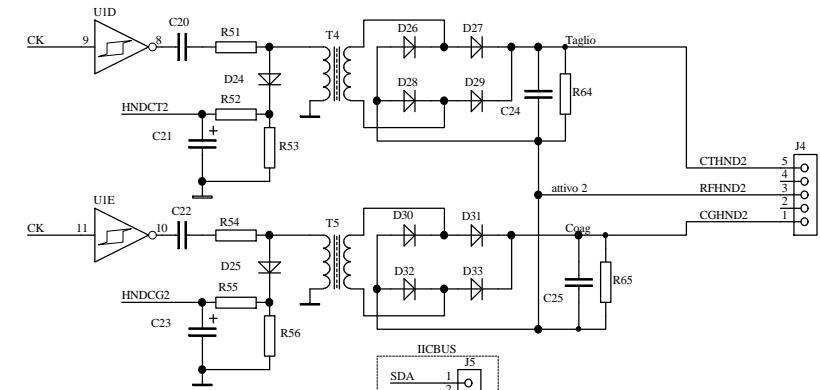
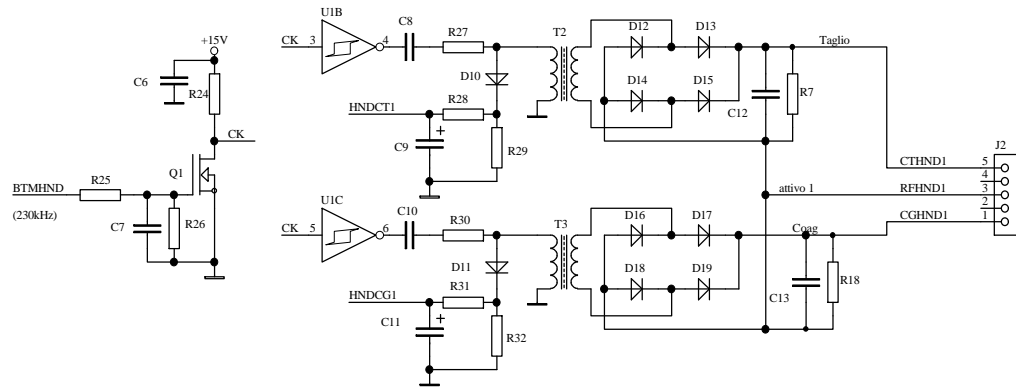
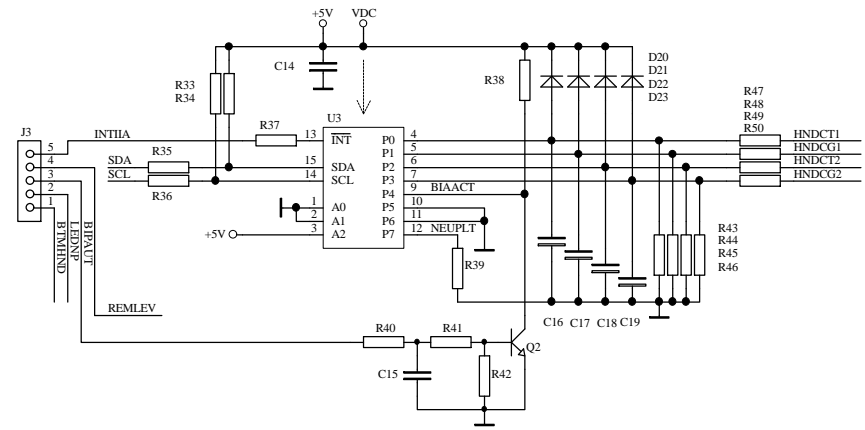
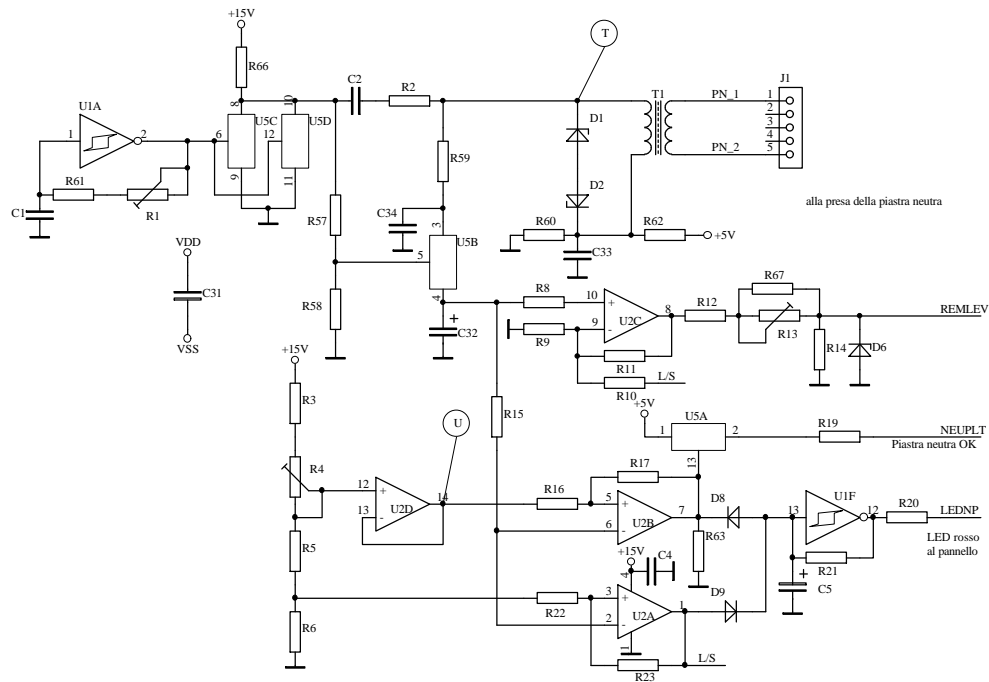

alsa apparecchi medicali s.r.l.		alsa botogna	
EXCELL mod. MCDS			
BIS 095J - Contr. Man. & Circuito P/N			
cod. alsa: 801308	Rev.:5.1		8/Jun/99
Drawn by:	Approval:		

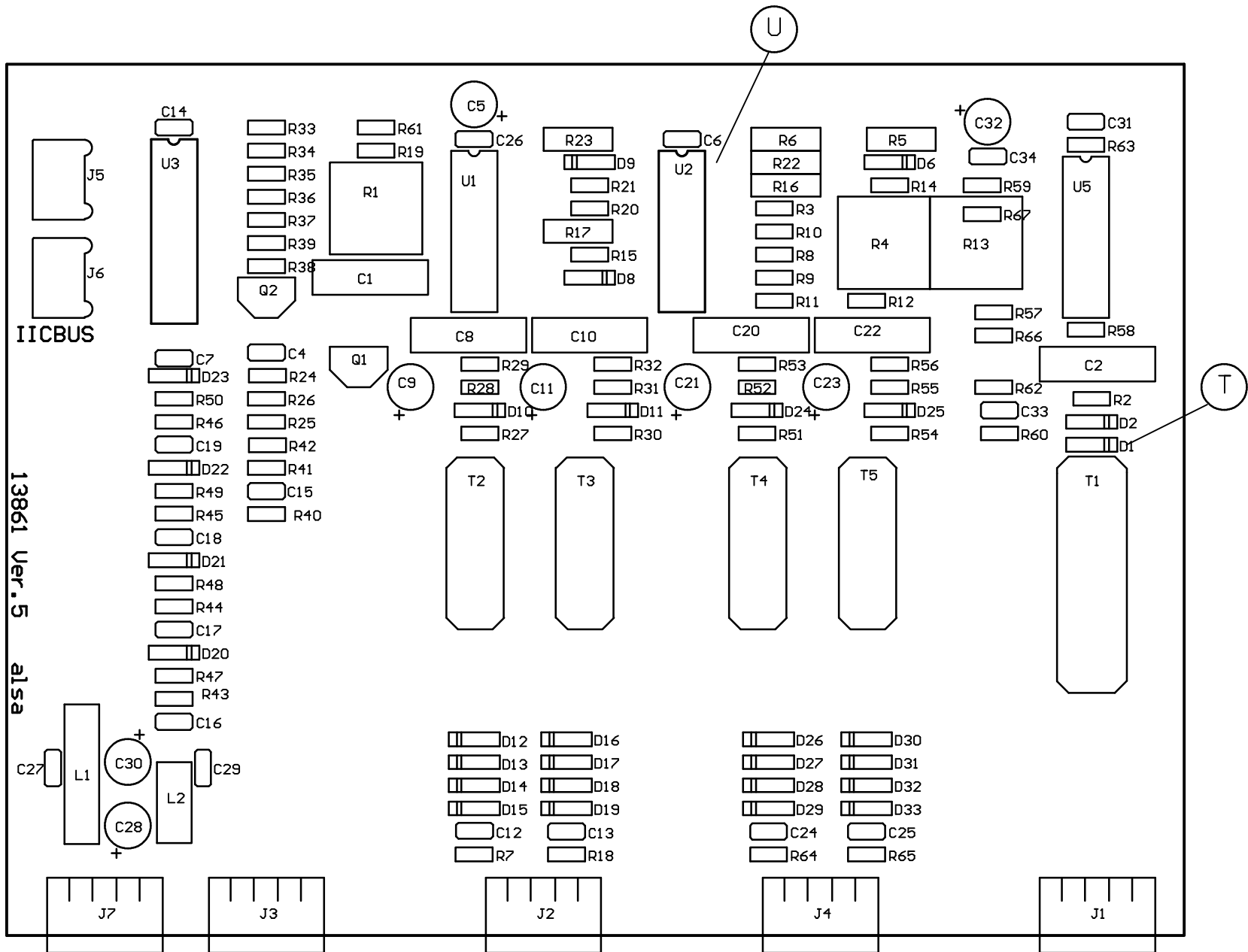

ELECTROSURGICAL UNIT EXCELL 400 MCDS**DOUBLE HANDLE & N/P CONTROL BOARD****alsa code: 801308****Rev.: 5.1****Last revised:****15-mar-99****Date:****12-gen-00****13.26**

Reference	Part Type	Description	alsa code
R1	100KT	PRESET POTENTIOMETER CERMET	403084
R2	820	METAL FILM RESISTOR 1/4 W 5%	430200
R3	3K9	METAL FILM RESISTOR 1/4 W 5%	430350
R4	1KT	PRESET POTENTIOMETER CERMET	403063
R5	200/1%	PRECISION RESISTOR 1% 0.6W	430481
R6	2K/1%	PRECISION RESISTOR 1% 0.6W	430461
R7	10K	METAL FILM RESISTOR 1/4 W 5%	430339
R8	10K	METAL FILM RESISTOR 1/4 W 5%	430339
R9	10K	METAL FILM RESISTOR 1/4 W 5%	430339
R10	10K	METAL FILM RESISTOR 1/4 W 5%	430339
R11	10K	METAL FILM RESISTOR 1/4 W 5%	430339
R12	100	METAL FILM RESISTOR 1/4 W 5%	430336
R13	NU	NOT USED	-----
R14	1K	METAL FILM RESISTOR 1/4 W 5%	430170
R15	1K	METAL FILM RESISTOR 1/4 W 5%	430170
R16	1K	METAL FILM RESISTOR 1/4 W 5%	430170
R17	330K	METAL FILM RESISTOR 1/4 W 5%	430173
R18	10K	METAL FILM RESISTOR 1/4 W 5%	430339
R19	100	METAL FILM RESISTOR 1/4 W 5%	430336
R20	820	METAL FILM RESISTOR 1/4 W 5%	430200
R21	33K	METAL FILM RESISTOR 1/4 W 5%	430172
R22	1K	METAL FILM RESISTOR 1/4 W 5%	430170
R23	330K	METAL FILM RESISTOR 1/4 W 5%	430173
R24	2K2	METAL FILM RESISTOR 1/4 W 5%	430343
R25	1K	METAL FILM RESISTOR 1/4 W 5%	430170
R26	10K	METAL FILM RESISTOR 1/4 W 5%	430339
R27	470	METAL FILM RESISTOR 1/4 W 5%	430169
R28	470	METAL FILM RESISTOR 1/4 W 5%	430169
R29	2K2	METAL FILM RESISTOR 1/4 W 5%	430343
R30	470	METAL FILM RESISTOR 1/4 W 5%	430169
R31	470	METAL FILM RESISTOR 1/4 W 5%	430169
R32	2K2	METAL FILM RESISTOR 1/4 W 5%	430343
R33	5K6	METAL FILM RESISTOR 1/4 W 5%	430344
R34	5K6	METAL FILM RESISTOR 1/4 W 5%	430344
R35	220	METAL FILM RESISTOR 1/4 W 5%	430358
R36	220	METAL FILM RESISTOR 1/4 W 5%	430358
R37	100	METAL FILM RESISTOR 1/4 W 5%	430336
R38	1K	METAL FILM RESISTOR 1/4 W 5%	430170
R39	4K7	METAL FILM RESISTOR 1/4 W 5%	430167
R40	4K7	METAL FILM RESISTOR 1/4 W 5%	430167
R41	1K	METAL FILM RESISTOR 1/4 W 5%	430170
R42	47K	METAL FILM RESISTOR 1/4 W 5%	430218
R43	100K	METAL FILM RESISTOR 1/4 W 5%	430177
R44	100K	METAL FILM RESISTOR 1/4 W 5%	430177
R45	100K	METAL FILM RESISTOR 1/4 W 5%	430177
R46	100K	METAL FILM RESISTOR 1/4 W 5%	430177
R47	1K	METAL FILM RESISTOR 1/4 W 5%	430170
R48	1K	METAL FILM RESISTOR 1/4 W 5%	430170
R49	1K	METAL FILM RESISTOR 1/4 W 5%	430170
R50	1K	METAL FILM RESISTOR 1/4 W 5%	430170
R51	470	METAL FILM RESISTOR 1/4 W 5%	430169
R52	470	METAL FILM RESISTOR 1/4 W 5%	430169
R53	2K2	METAL FILM RESISTOR 1/4 W 5%	430343
R54	470	METAL FILM RESISTOR 1/4 W 5%	430169
R55	470	METAL FILM RESISTOR 1/4 W 5%	430169
R56	2K2	METAL FILM RESISTOR 1/4 W 5%	430343
R57	1K	METAL FILM RESISTOR 1/4 W 5%	430170
R58	10K	METAL FILM RESISTOR 1/4 W 5%	430339
R59	3K3	METAL FILM RESISTOR 1/4 W 5%	430197

Reference	Part Type	Description	alsa code
R60	1K5	METAL FILM RESISTOR 1/4 W 5%	430199
R61	47K	METAL FILM RESISTOR 1/4 W 5%	430218
R62	1K	METAL FILM RESISTOR 1/4 W 5%	430170
R63	10K	METAL FILM RESISTOR 1/4 W 5%	430339
R64	10K	METAL FILM RESISTOR 1/4 W 5%	430339
R65	10K	METAL FILM RESISTOR 1/4 W 5%	430339
R66	1K	METAL FILM RESISTOR 1/4 W 5%	430170
R67	220	METAL FILM RESISTOR 1/4 W 5%	430358
C1	220p/P/400V	METALLIZED POLYESTER CAPACITOR	400280
C2	15n/P	METALLIZED POLYESTER CAPACITOR	400191
C4	100n	CERAMIC CAPACITOR	400139
C5	10u/T/35V	TANTALUM ELECTROLYTIC CAPACITOR	400134
C6	100n	CERAMIC CAPACITOR	400139
C7	100p/NPO	NPO CERAMIC CAPACITOR	400260
C8	15n/P	METALLIZED POLYESTER CAPACITOR	400191
C9	10u/T/35V	TANTALUM ELECTROLYTIC CAPACITOR	400134
C10	15n/P	METALLIZED POLYESTER CAPACITOR	400191
C11	10u/T/35V	TANTALUM ELECTROLYTIC CAPACITOR	400134
C12	100n	CERAMIC CAPACITOR	400139
C13	100n	CERAMIC CAPACITOR	400139
C14	100n	CERAMIC CAPACITOR	400139
C15	100n	CERAMIC CAPACITOR	400139
C16	10n	CERAMIC CAPACITOR	400251
C17	10n	CERAMIC CAPACITOR	400251
C18	10n	CERAMIC CAPACITOR	400251
C19	10n	CERAMIC CAPACITOR	400251
C20	15n/P	METALLIZED POLYESTER CAPACITOR	400191
C21	10u/T/35V	TANTALUM ELECTROLYTIC CAPACITOR	400134
C22	15n/P	METALLIZED POLYESTER CAPACITOR	400191
C23	10u/T/35V	TANTALUM ELECTROLYTIC CAPACITOR	400134
C24	100n	CERAMIC CAPACITOR	400139
C25	100n	CERAMIC CAPACITOR	400139
C26	100n	CERAMIC CAPACITOR	400139
C27	100n	CERAMIC CAPACITOR	400139
C28	47u/E/35V	VERTICAL ELECTROLYTIC CAPACITOR	400237
C29	100n	CERAMIC CAPACITOR	400139
C30	47u/E/35V	VERTICAL ELECTROLYTIC CAPACITOR	400237
C31	100n	CERAMIC CAPACITOR	400139
C32	1u/T/35V	TANTALUM ELECTROLYTIC CAPACITOR	400173
C33	100n	CERAMIC CAPACITOR	400139
C34	100P/NPO	NPO CERAMIC CAPACITOR	400260
D1	15V/0.5W	ZENER DIODE 15V/0.5W	420030
D2	15V/0.5W	ZENER DIODE 15V/0.5W	420030
D6	5V6/0.5W	ZENER DIODE 5V6/0.5W	420018
D8	1N4148	DIODE	420010
D9	1N4148	DIODE	420010
D10	1N4148	DIODE	420010
D11	1N4148	DIODE	420010
D12	1N4148	DIODE	420010
D13	1N4148	DIODE	420010
D14	1N4148	DIODE	420010
D15	1N4148	DIODE	420010
D16	1N4148	DIODE	420010
D17	1N4148	DIODE	420010
D18	1N4148	DIODE	420010
D19	1N4148	DIODE	420010
D20	1N4148	DIODE	420010
D21	1N4148	DIODE	420010
D22	1N4148	DIODE	420010
D23	1N4148	DIODE	420010
D24	1N4148	DIODE	420010
D25	1N4148	DIODE	420010
D26	1N4148	DIODE	420010

Reference	Part Type	Description	alsa code
D27	1N4148	DIODE	420010
D28	1N4148	DIODE	420010
D29	1N4148	DIODE	420010
D30	1N4148	DIODE	420010
D31	1N4148	DIODE	420010
D32	1N4148	DIODE	420010
D33	1N4148	DIODE	420010
Q1	VN10KM	N CHANNEL MOSFET	427054
Q2	BC237B	NPN TRANSISTOR	427057
L1	6uH8/800mA	INDUCTOR	422007
L2	100uH/275mA	INDUCTOR	422006
U1	40106	CMOS CD40106	482023
U2	LM324	OP.AMP. LM324	482030
U3	PCF8574	II_CBUS I/O EXPANDER	482089
U5	4066	CMOS CD4066	482017
T1	PN_TRASF	NEUTRAL PLATE CIRCUIT TRANSFORMER	713913
T2	CUT_TRASF	TRANSFORMER FOR HANDLE CUT ACTIVATION	713912
T3	COAG_TRASF	TRANSFORMER FOR HANDLE COAG ACTIVATION	713912
T4	CUT_TRASF	TRANSFORMER FOR HANDLE CUT ACTIVATION	713912
T5	COAG_TRASF	TRANSFORMER FOR HANDLE COAG ACTIVATION	713912
J1	384034	5 POLES PCB CONNECTOR MOLEX FEMALE 90°	384034
J2	384034	5 POLES PCB CONNECTOR MOLEX FEMALE 90°	384034
J3	384034	5 POLES PCB CONNECTOR MOLEX FEMALE 90°	384034
J4	384034	5 POLES PCB CONNECTOR MOLEX FEMALE 90°	384034
J5	PICO_4	4 POLES PICOFLEX CONN. MALE P.C.B.	384042
J6	PICO_4	4 POLES PICOFLEX CONN. MALE P.C.B.	384042
J7	384034	5 POLES PCB CONNECTOR MOLEX FEMALE 90°	384034

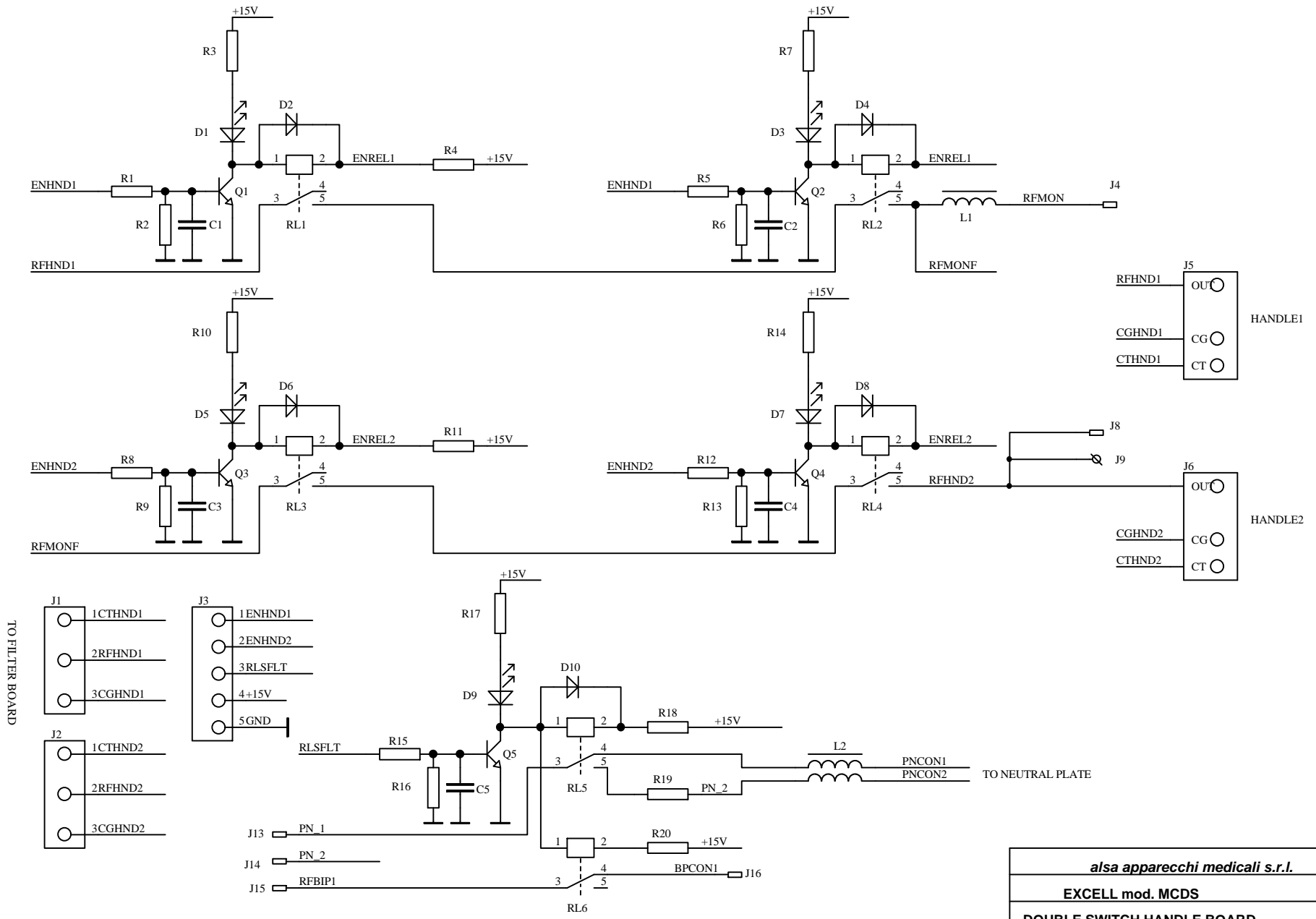

alsa apparecchi medicali s.r.l.		
EXCELL mod. MCDS		
DOUBLE SWITCH HANDLE BOARD		
alsa code: 801309	rev.: 2	14/Sep/99
Drawn by:		Approval:



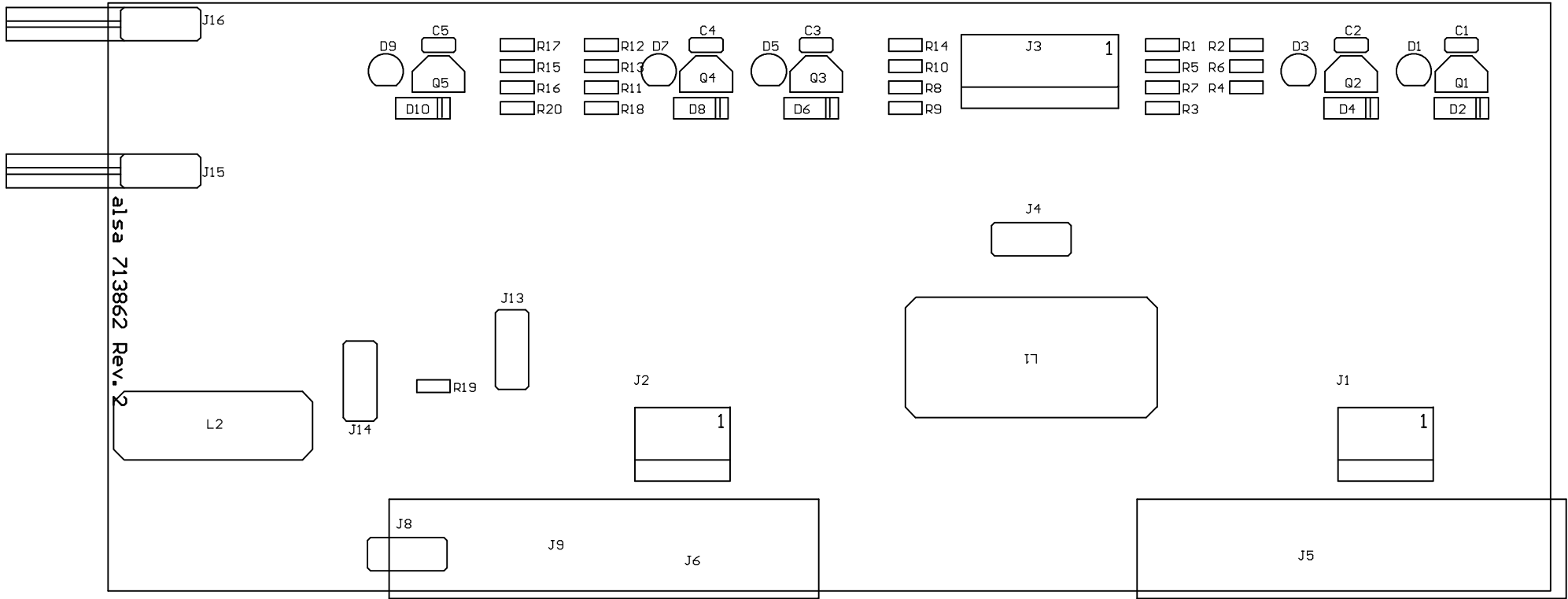

ELECTROSURGICAL UNIT EXCELL 400 MCDS**DOUBLE SWITCH HANDLE BOARD***alsa code: 801309 Rev.: 2**Last revised: 14-sep-98 Date: 12-gen-00 13.27*

Reference	Part Type	Description	alsa code
R1	4K7	METAL FILM RESISTOR 1/4 W 5%	430167
R2	10K	METAL FILM RESISTOR 1/4 W 5%	430339
R3	NU	NOT USED	-----
R4	47	METAL FILM RESISTOR 1/4 W 5%	430334
R5	4K7	METAL FILM RESISTOR 1/4 W 5%	430167
R6	10K	METAL FILM RESISTOR 1/4 W 5%	430339
R7	NU	NOT USED	-----
R8	4K7	METAL FILM RESISTOR 1/4 W 5%	430167
R9	10K	METAL FILM RESISTOR 1/4 W 5%	430339
R10	NU	NOT USED	-----
R11	47	METAL FILM RESISTOR 1/4 W 5%	430334
R12	4K7	METAL FILM RESISTOR 1/4 W 5%	430167
R13	10K	METAL FILM RESISTOR 1/4 W 5%	430339
R14	NU	NOT USED	-----
R15	10K	METAL FILM RESISTOR 1/4 W 5%	430339
R16	47K	METAL FILM RESISTOR 1/4 W 5%	430218
R17	NU	NOT USED	-----
R18	47	METAL FILM RESISTOR 1/4 W 5%	430334
R19	820	METAL FILM RESISTOR 1/4 W 5%	430200
R20	47	METAL FILM RESISTOR 1/4 W 5%	430334
C1	100n	CERAMIC CAPACITOR	400139
C2	100n	CERAMIC CAPACITOR	400139a
C3	100n	CERAMIC CAPACITOR	400139
C4	100n	CERAMIC CAPACITOR	400139
C5	100n	CERAMIC CAPACITOR	400139
D1	NU	NOT USED	-----
D2	1N4007	DIODE	420001
D3	NU	NOT USED	-----
D4	1N4007	DIODE	420001
D5	NU	NOT USED	-----
D6	1N4007	DIODE	420001
D7	NU	NOT USED	-----
D8	1N4007	DIODE	420001
D9	NU	NOT USED	-----
D10	1N4007	DIODE	420001
Q1	BC237B	NPN TRANSISTOR	427057
Q2	BC237B	NPN TRANSISTOR	427057
Q3	BC237B	NPN TRANSISTOR	427057
Q4	BC237B	NPN TRANSISTOR	427057
Q5	BC237B	NPN TRANSISTOR	427057
L1	NU	NOT USED	-----
L2	T130_1	RING CORE	499227
RL1	V23061	RELAY SIEMENS	404044
RL2	V23061	RELAY SIEMENS	404044
RL3	V23061	RELAY SIEMENS	404044
RL4	V23061	RELAY SIEMENS	404044
RL5	V23061	RELAY SIEMENS	404044
RL6	V23061	RELAY SIEMENS	404044
J1	PAND_3P	3 POLES PCB CONNECTOR PANDUIT MALE	384036
J2	PAND_3P	3 POLES PCB CONNECTOR PANDUIT MALE	384036
J3	384016	5 POLES PCB CONNECTOR MASCON	384016
J4	399028	FASTON CONNECTOR P.C.B.	399028
J5	PAD_CI	PAD	-----
J6	PAD_CI	PAD	-----
J8	NU	NOT USED	-----

Reference	Part Type	Description	alsa code
J9	PAD_CI	PAD	-----
J13	399028	FASTON CONNECTOR P.C.B.	399028
J14	399028	FASTON CONNECTOR P.C.B.	399028
J15	399029	FASTON CONNECTOR P.C.B 90ø	399029
J16	399029	FASTON CONNECTOR P.C.B 90ø	399029

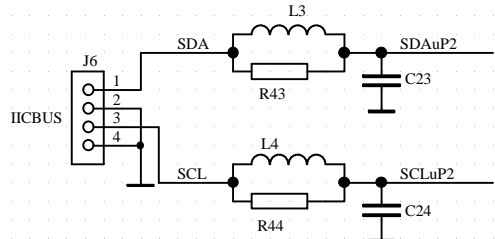
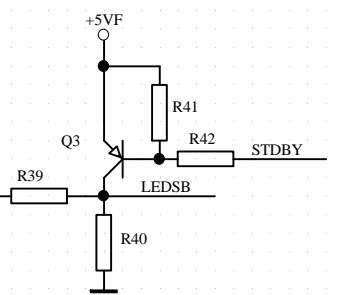
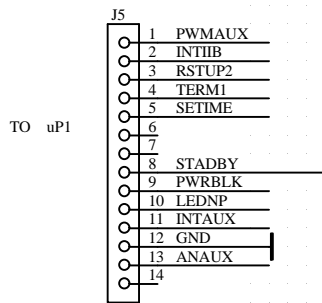
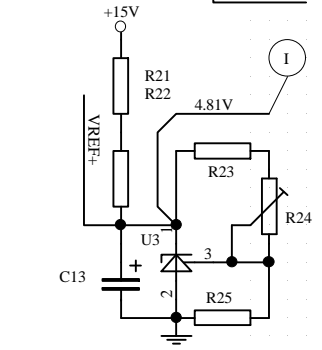
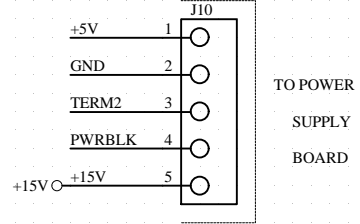
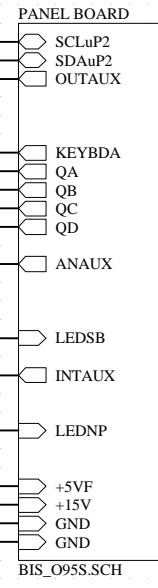
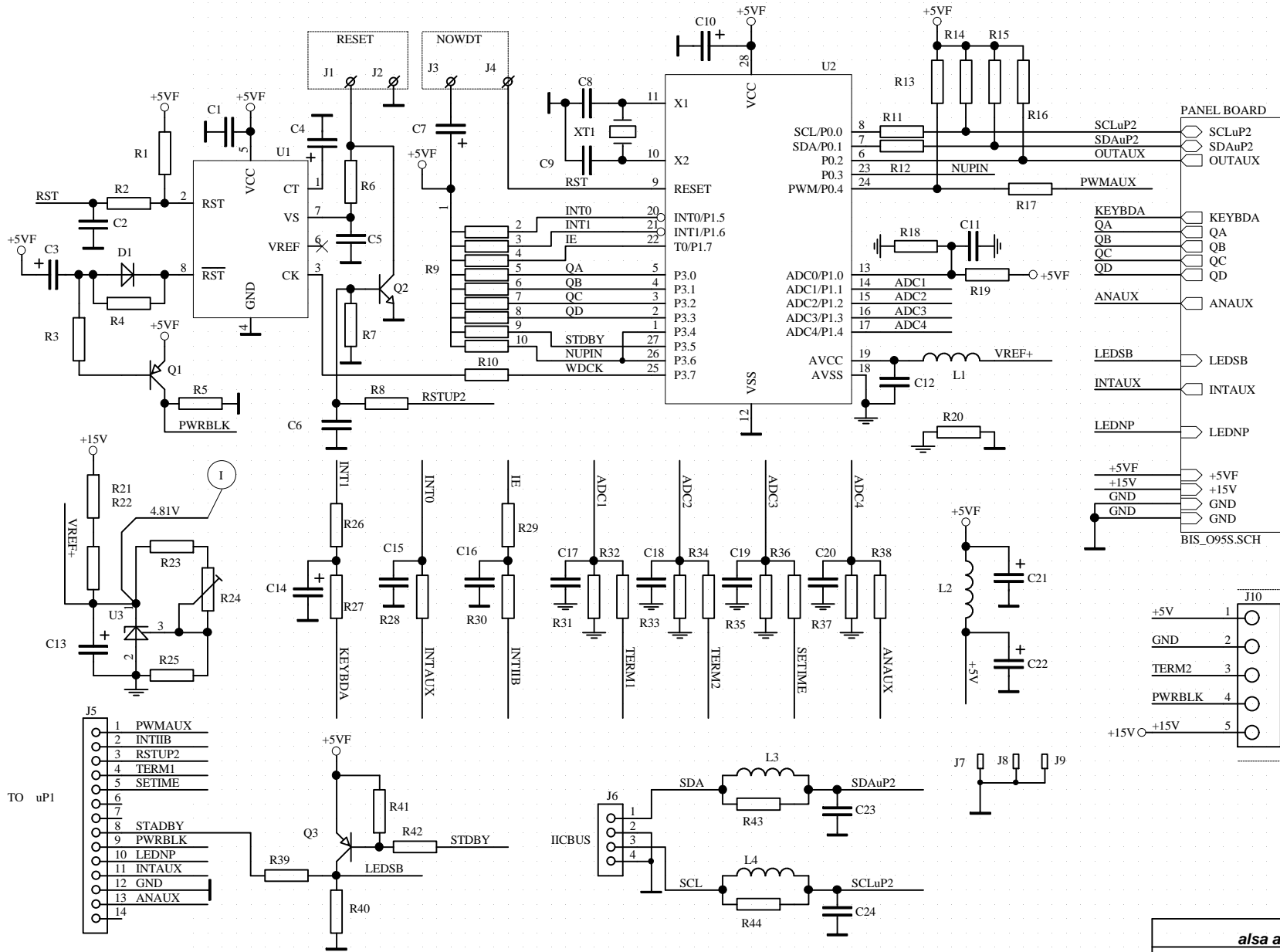

alsa apparecchi medicali s.r.l.		
EXCELL mod. MCDS		
BIS_095 - SEZIONE uP2		
alsa code: 801310	Rev.: 4.1	3/Dec/98
Drawn by:		Approval:



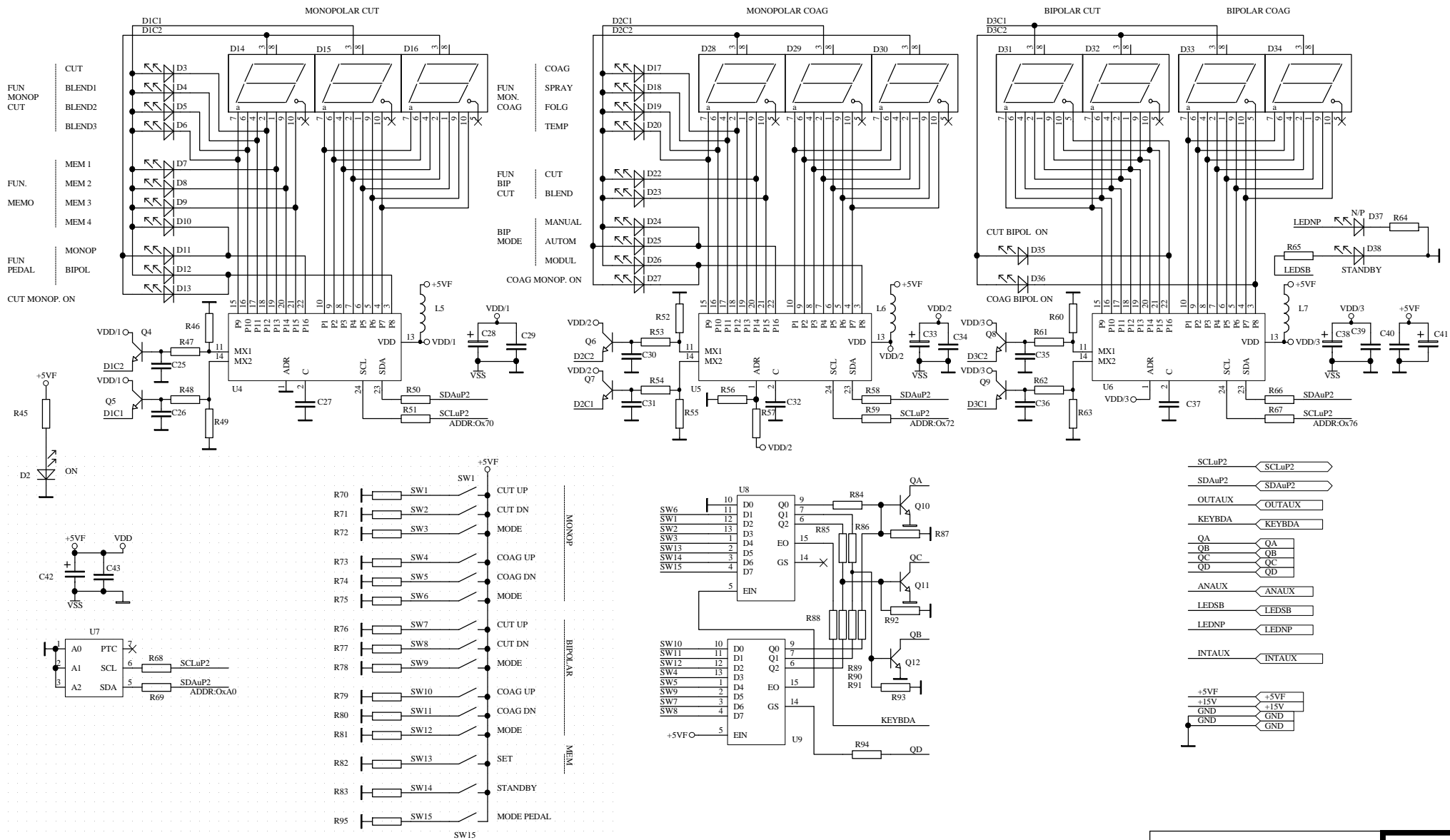

<i>alsa apparecchi medicali s.r.l.</i>		alsa botogna	
EXCELL mod. MCDS			
BIS 095S - DISPLAY E PANNELLO COMANDI			
alsa code: 801310	Rev.: 4.1B		4/Dec/98
Drawn by:	Approval:		

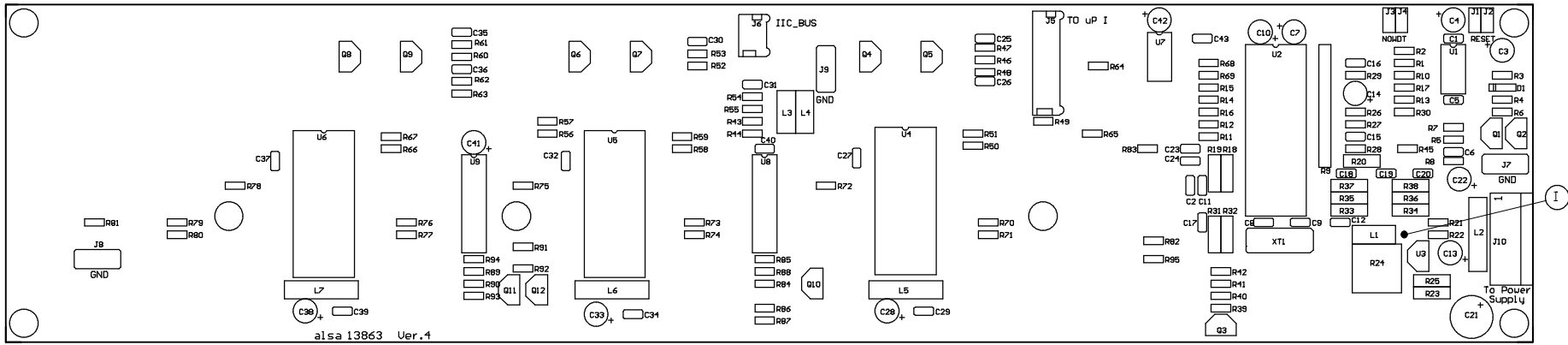

alsa 13863 Ver.4

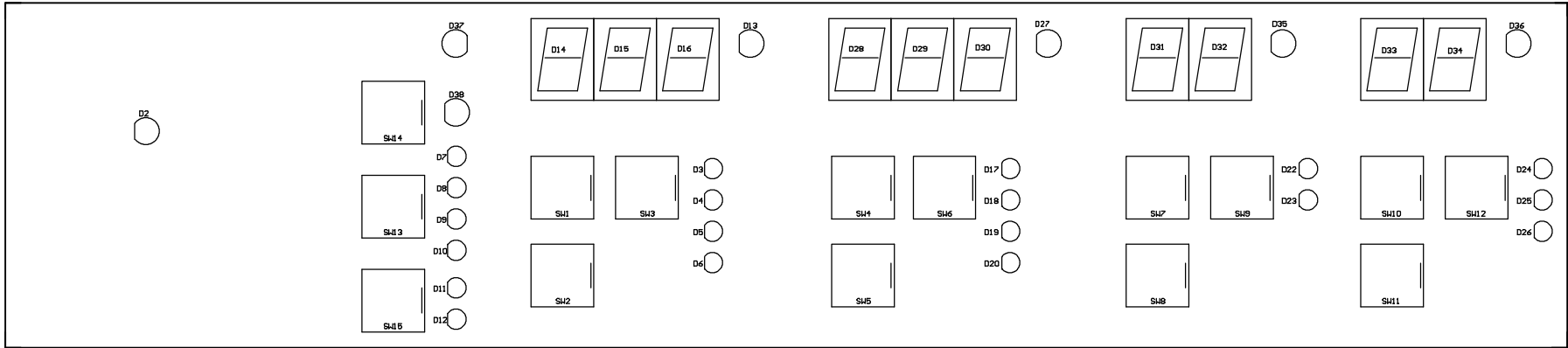

ELECTROSURGICAL UNIT EXCELL 400 MCDS**PANEL BOARD****alsa code: 801310 Rev.: 4.1****Last revised: 3-dec-98 Date: 12-gen-00 13.27**

Reference	Part Type	Description	alsa code
R1	10K	METAL FILM RESISTOR 1/4 W 5%	430339
R2	100	METAL FILM RESISTOR 1/4 W 5%	430336
R3	10K	METAL FILM RESISTOR 1/4 W 5%	430339
R4	10K	METAL FILM RESISTOR 1/4 W 5%	430339
R5	1K5	METAL FILM RESISTOR 1/4 W 5%	430199
R6	1K	METAL FILM RESISTOR 1/4 W 5%	430170
R7	4K7	METAL FILM RESISTOR 1/4 W 5%	430167
R8	10K	METAL FILM RESISTOR 1/4 W 5%	430339
R9	X_RNET10K	RESISTOR NETWORK 10K	430484
R10	1K	METAL FILM RESISTOR 1/4 W 5%	430170
R11	220	METAL FILM RESISTOR 1/4 W 5%	430358
R12	220	METAL FILM RESISTOR 1/4 W 5%	430358
R13	10K	METAL FILM RESISTOR 1/4 W 5%	430339
R14	10K	METAL FILM RESISTOR 1/4 W 5%	430339
R15	10K	METAL FILM RESISTOR 1/4 W 5%	430339
R16	10K	METAL FILM RESISTOR 1/4 W 5%	430339
R17	100	METAL FILM RESISTOR 1/4 W 5%	430336
R18	3K/1%	PRECISION RESISTOR 1% 0.6W	430459
R19	3K/1%	PRECISION RESISTOR 1% 0.6W	430459
R20	0/0	0 OHM RESISTOR	430446
R21	470	METAL FILM RESISTOR 1/4 W 5%	430169
R22	470	METAL FILM RESISTOR 1/4 W 5%	430169
R23	1270/1%	METAL FILM RESISTOR 1/4 W 5%	430351
R24	5KT	PRESET POTENTIOMETER CERMET	403052
R25	4120/1%	PRECISION RESISTOR 1% 0.6W	430483
R26	100	METAL FILM RESISTOR 1/4 W 5%	430336
R27	100	METAL FILM RESISTOR 1/4 W 5%	430336
R28	100	METAL FILM RESISTOR 1/4 W 5%	430336
R29	100	METAL FILM RESISTOR 1/4 W 5%	430336
R30	1K	METAL FILM RESISTOR 1/4 W 5%	430170
R31	11K/1%	PRECISION RESISTOR 1% 0.6W	430467
R32	1K/1%	PRECISION RESISTOR 1% 0.6W	430458
R33	11K/1%	PRECISION RESISTOR 1% 0.6W	430467
R34	1K/1%	PRECISION RESISTOR 1% 0.6W	430458
R35	11K/1%	PRECISION RESISTOR 1% 0.6W	430467
R36	1K/1%	PRECISION RESISTOR 1% 0.6W	430458
R37	11K/1%	PRECISION RESISTOR 1% 0.6W	430467
R38	1K/1%	PRECISION RESISTOR 1% 0.6W	430458
R39	100	METAL FILM RESISTOR 1/4 W 5%	430336
R40	470	METAL FILM RESISTOR 1/4 W 5%	430169
R41	22K	METAL FILM RESISTOR 1/4 W 5%	430179
R42	2K2	METAL FILM RESISTOR 1/4 W 5%	430343
R43	1K	METAL FILM RESISTOR 1/4 W 5%	430170
R44	1K	METAL FILM RESISTOR 1/4 W 5%	430170
R45	560	METAL FILM RESISTOR 1/4 W 5%	430178
R46	1K	METAL FILM RESISTOR 1/4 W 5%	430170
R47	100	METAL FILM RESISTOR 1/4 W 5%	430336
R48	100	METAL FILM RESISTOR 1/4 W 5%	430336
R49	1K	METAL FILM RESISTOR 1/4 W 5%	430170
R50	220	METAL FILM RESISTOR 1/4 W 5%	430358
R51	220	METAL FILM RESISTOR 1/4 W 5%	430358
R52	1K	METAL FILM RESISTOR 1/4 W 5%	430170
R53	100	METAL FILM RESISTOR 1/4 W 5%	430336
R54	100	METAL FILM RESISTOR 1/4 W 5%	430336
R55	1K	METAL FILM RESISTOR 1/4 W 5%	430170
R56	10K	METAL FILM RESISTOR 1/4 W 5%	430339
R57	15K	METAL FILM RESISTOR 1/4 W 5%	430345
R58	220	METAL FILM RESISTOR 1/4 W 5%	430358

Reference	Part Type	Description	alsa code
R59	220	METAL FILM RESISTOR 1/4 W 5%	430358
R60	1K	METAL FILM RESISTOR 1/4 W 5%	430170
R61	100	METAL FILM RESISTOR 1/4 W 5%	430336
R62	100	METAL FILM RESISTOR 1/4 W 5%	430336
R63	1K	METAL FILM RESISTOR 1/4 W 5%	430170
R64	330	METAL FILM RESISTOR 1/4 W 5%	430171
R65	330	METAL FILM RESISTOR 1/4 W 5%	430171
R66	220	METAL FILM RESISTOR 1/4 W 5%	430358
R67	220	METAL FILM RESISTOR 1/4 W 5%	430358
R68	220	METAL FILM RESISTOR 1/4 W 5%	430358
R69	220	METAL FILM RESISTOR 1/4 W 5%	430358
R70	1K8	METAL FILM RESISTOR 1/4 W 5%	430198
R71	1K8	METAL FILM RESISTOR 1/4 W 5%	430198
R72	1K8	METAL FILM RESISTOR 1/4 W 5%	430198
R73	1K8	METAL FILM RESISTOR 1/4 W 5%	430198
R74	1K8	METAL FILM RESISTOR 1/4 W 5%	430198
R75	1K8	METAL FILM RESISTOR 1/4 W 5%	430198
R76	1K8	METAL FILM RESISTOR 1/4 W 5%	430198
R77	1K8	METAL FILM RESISTOR 1/4 W 5%	430198
R78	1K8	METAL FILM RESISTOR 1/4 W 5%	430198
R79	1K8	METAL FILM RESISTOR 1/4 W 5%	430198
R80	1K8	METAL FILM RESISTOR 1/4 W 5%	430198
R81	1K8	METAL FILM RESISTOR 1/4 W 5%	430198
R82	1K8	METAL FILM RESISTOR 1/4 W 5%	430198
R83	1K8	METAL FILM RESISTOR 1/4 W 5%	430198
R84	22K	METAL FILM RESISTOR 1/4 W 5%	430179
R85	22K	METAL FILM RESISTOR 1/4 W 5%	430179
R86	22K	METAL FILM RESISTOR 1/4 W 5%	430179
R87	22K	METAL FILM RESISTOR 1/4 W 5%	430179
R88	100	METAL FILM RESISTOR 1/4 W 5%	430336
R89	22K	METAL FILM RESISTOR 1/4 W 5%	430179
R90	22K	METAL FILM RESISTOR 1/4 W 5%	430179
R91	22K	METAL FILM RESISTOR 1/4 W 5%	430179
R92	22K	METAL FILM RESISTOR 1/4 W 5%	430179
R93	22K	METAL FILM RESISTOR 1/4 W 5%	430179
R94	100	METAL FILM RESISTOR 1/4 W 5%	430336
R95	1K8	METAL FILM RESISTOR 1/4 W 5%	430198
C1	100n	CERAMIC CAPACITOR	400139
C2	100n	CERAMIC CAPACITOR	400139
C3	10u/T/35V	TANTALUM ELECTROLYTIC CAPACITOR	400134
C4	1u/T/35V	TANTALUM ELECTROLYTIC CAPACITOR	400173
C5	100n	CERAMIC CAPACITOR	400139
C6	10n	CERAMIC CAPACITOR	400251
C7	10u/T/35V	TANTALUM ELECTROLYTIC CAPACITOR	400134
C8	22p/C	CERAMIC CAPACITOR	400290
C9	22p/C	CERAMIC CAPACITOR	400290
C10	10u/T/35V	TANTALUM ELECTROLYTIC CAPACITOR	400134
C11	100n	CERAMIC CAPACITOR	400139
C12	10n	CERAMIC CAPACITOR	400251
C13	10u/T/35V	TANTALUM ELECTROLYTIC CAPACITOR	400134
C14	1U/T/35V	TANTALUM ELECTROLYTIC CAPACITOR	400173
C15	100n	CERAMIC CAPACITOR	400139
C16	100n	CERAMIC CAPACITOR	400139
C17	100n	CERAMIC CAPACITOR	400139
C18	100n	CERAMIC CAPACITOR	400139
C19	100n	CERAMIC CAPACITOR	400139
C20	100n	CERAMIC CAPACITOR	400139
C21	47u/E/50V	ELECTROLYTIC CAPACITOR	400296
C22	10u/T/35V	TANTALUM ELECTROLYTIC CAPACITOR	400134
C23	100p/NPO	NPO CERAMIC CAPACITOR	400260
C24	100p/NPO	NPO CERAMIC CAPACITOR	400260
C25	1N/C	CERAMIC CAPACITOR	400252

Reference	Part Type	Description	alsa code
C26	1N/C	CERAMIC CAPACITOR	400252
C27	2n2/C	CERAMIC CAPACITOR	400261
C28	10u/T/35V	TANTALUM ELECTROLYTIC CAPACITOR	400134
C29	100n	CERAMIC CAPACITOR	400139
C30	1N/C	CERAMIC CAPACITOR	400252
C31	1N/C	CERAMIC CAPACITOR	400252
C32	2n2/C	CERAMIC CAPACITOR	400261
C33	10u/T/35V	TANTALUM ELECTROLYTIC CAPACITOR	400134
C34	100n	CERAMIC CAPACITOR	400139
C35	1N/C	CERAMIC CAPACITOR	400252
C36	1N/C	CERAMIC CAPACITOR	400252
C37	2n2/C	CERAMIC CAPACITOR	400261
C38	10u/T/35V	TANTALUM ELECTROLYTIC CAPACITOR	400134
C39	100n	CERAMIC CAPACITOR	400139
C40	100n	CERAMIC CAPACITOR	400139
C41	10u/T/35V	TANTALUM ELECTROLYTIC CAPACITOR	400134
C42	10u/T/35V	TANTALUM ELECTROLYTIC CAPACITOR	400134
C43	100n	CERAMIC CAPACITOR	400139
D1	1N4148	DIODE	420010
D2	GL5HG8	GREEN LED LAMP 5MM	420037
D3	LEDG3	GREEN LED LAMP 3MM	420079
D4	LEDG3	GREEN LED LAMP 3MM	420079
D5	LEDG3	GREEN LED LAMP 3MM	420079
D6	LEDG3	GREEN LED LAMP 3MM	420079
D7	LEDG3	GREEN LED LAMP 3MM	420079
D8	LEDG3	GREEN LED LAMP 3MM	420079
D9	LEDG3	GREEN LED LAMP 3MM	420079
D10	LEDG3	GREEN LED LAMP 3MM	420079
D11	LEDG3	GREEN LED LAMP 3MM	420079
D12	LEDG3	GREEN LED LAMP 3MM	420079
D13	GL5HY8	YELLOW LED LAMP 5MM	420036
D14	HDSP5501	HIGH EFFICIENCY 7 SEGMENT DISPLAY	420080
D15	HDSP5501	HIGH EFFICIENCY 7 SEGMENT DISPLAY	420080
D16	HDSP5501	HIGH EFFICIENCY 7 SEGMENT DISPLAY	420080
D17	LEDG3	GREEN LED LAMP 3MM	420079
D18	LEDG3	GREEN LED LAMP 3MM	420079
D19	LEDG3	GREEN LED LAMP 3MM	420079
D20	LEDG3	GREEN LED LAMP 3MM	420079
D22	LEDG3	GREEN LED LAMP 3MM	420079
D23	LEDG3	GREEN LED LAMP 3MM	420079
D24	LEDG3	GREEN LED LAMP 3MM	420079
D25	LEDG3	GREEN LED LAMP 3MM	420079
D26	LEDG3	GREEN LED LAMP 3MM	420079
D27	GL5HB8	BLUE LED LAMP 5MM	420092
D28	HDSP5501	HIGH EFFICIENCY 7 SEGMENT DISPLAY	420080
D29	HDSP5501	HIGH EFFICIENCY 7 SEGMENT DISPLAY	420080
D30	HDSP5501	HIGH EFFICIENCY 7 SEGMENT DISPLAY	420080
D31	HDSP5501	HIGH EFFICIENCY 7 SEGMENT DISPLAY	420080
D32	HDSP5501	HIGH EFFICIENCY 7 SEGMENT DISPLAY	420080
D33	HDSP5501	HIGH EFFICIENCY 7 SEGMENT DISPLAY	420080
D34	HDSP5501	HIGH EFFICIENCY 7 SEGMENT DISPLAY	420080
D35	GL5HY8	YELLOW LED LAMP 5MM	420036
D36	GL5HB8	BLUE LED LAMP 5MM	420092
D37	GL5HR8	RED LED LAMP 5MM	420025
D38	GL5HO8	INTERMITTENT 5MM LED LAMP	420093
Q1	BC557	PNP TRANSISTOR	427058
Q2	BC237B	NPN TRANSISTOR	427057
Q3	BC557	PNP TRANSISTOR	427058
Q4	BC237B	NPN TRANSISTOR	427057
Q5	BC237B	NPN TRANSISTOR	427057
Q6	BC237B	NPN TRANSISTOR	427057
Q7	BC237B	NPN TRANSISTOR	427057

Reference	Part Type	Description	alsa code
Q8	BC237B	NPN TRANSISTOR	427057
Q9	BC237B	NPN TRANSISTOR	427057
Q10	BC237B	NPN TRANSISTOR	427057
Q11	BC237B	NPN TRANSISTOR	427057
Q12	BC237B	NPN TRANSISTOR	427057
L1	100uH/275mA	INDUCTOR	422006
L2	6UH8/800mA	INDUCTOR	422007
L3	100uH/275mA	INDUCTOR	422006
L4	100uH/275mA	INDUCTOR	422006
L5	6UH8/800MA	INDUCTOR	422007
L6	6UH8/800MA	INDUCTOR	422007
L7	6UH8/800MA	INDUCTOR	422007
U1	MB3773	WATCH-DOG TIMER	482088
U2	87C752_MCDS	12 MHZ MICROCONTROLLER (PROGR.)	713921
U3	LM431	VOLTAGE REGULATOR	482078
U4	SAA1064	DISPLAY DECODER	482080
U5	SAA1064	DISPLAY DECODER	482080
U6	SAA1064	DISPLAY DECODER	482080
U7	PCF8582	EEPROM I ² _CBUS PHILIPS	482083
U8	4532	ENCODER 8 BIT	482081
U9	4532	ENCODER 8 BIT	482081
XT1	12Mhz/HC18	QUARTZ CRYSTAL 12 MHZ	252005
SW1	MTG_1241	PUSHBUTTON SCHURTER	416094
SW2	MTG_1241	PUSHBUTTON SCHURTER	416094
SW3	MTG_1241	PUSHBUTTON SCHURTER	416094
SW4	MTG_1241	PUSHBUTTON SCHURTER	416094
SW5	MTG_1241	PUSHBUTTON SCHURTER	416094
SW6	MTG_1241	PUSHBUTTON SCHURTER	416094
SW7	MTG_1241	PUSHBUTTON SCHURTER	416094
SW8	MTG_1241	PUSHBUTTON SCHURTER	416094
SW9	MTG_1241	PUSHBUTTON SCHURTER	416094
SW10	MTG_1241	PUSHBUTTON SCHURTER	416094
SW11	MTG_1241	PUSHBUTTON SCHURTER	416094
SW12	MTG_1241	PUSHBUTTON SCHURTER	416094
SW13	MTG_1241	PUSHBUTTON SCHURTER	416094
SW14	MTG_1241	PUSHBUTTON SCHURTER	416094
SW15	MTG_1241	PUSHBUTTON SCHURTER	416094
J1	PAD_CI	PAD	-----
J2	PAD_CI	PAD	-----
J3	PAD_CI	PAD	-----
J4	PAD_CI	PAD	-----
J5	PICO_14	14 POLES PICOFLEX CONN. MALE P.C.B.	384040
J6	PICO_4	4 POLES PICOFLEX CONN. MALE P.C.B.	384042
J7	399028	FASTON CONNECTOR P.C.B.	399028
J8	399028	FASTON CONNECTOR P.C.B.	399028
J9	399028	FASTON CONNECTOR P.C.B.	399028
J10	384016	5 POLES PCB CONNECTOR MASCON	384016

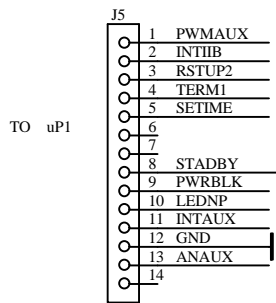
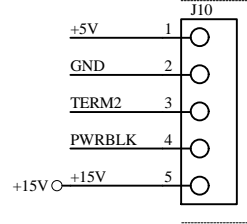
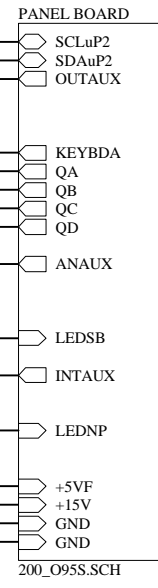
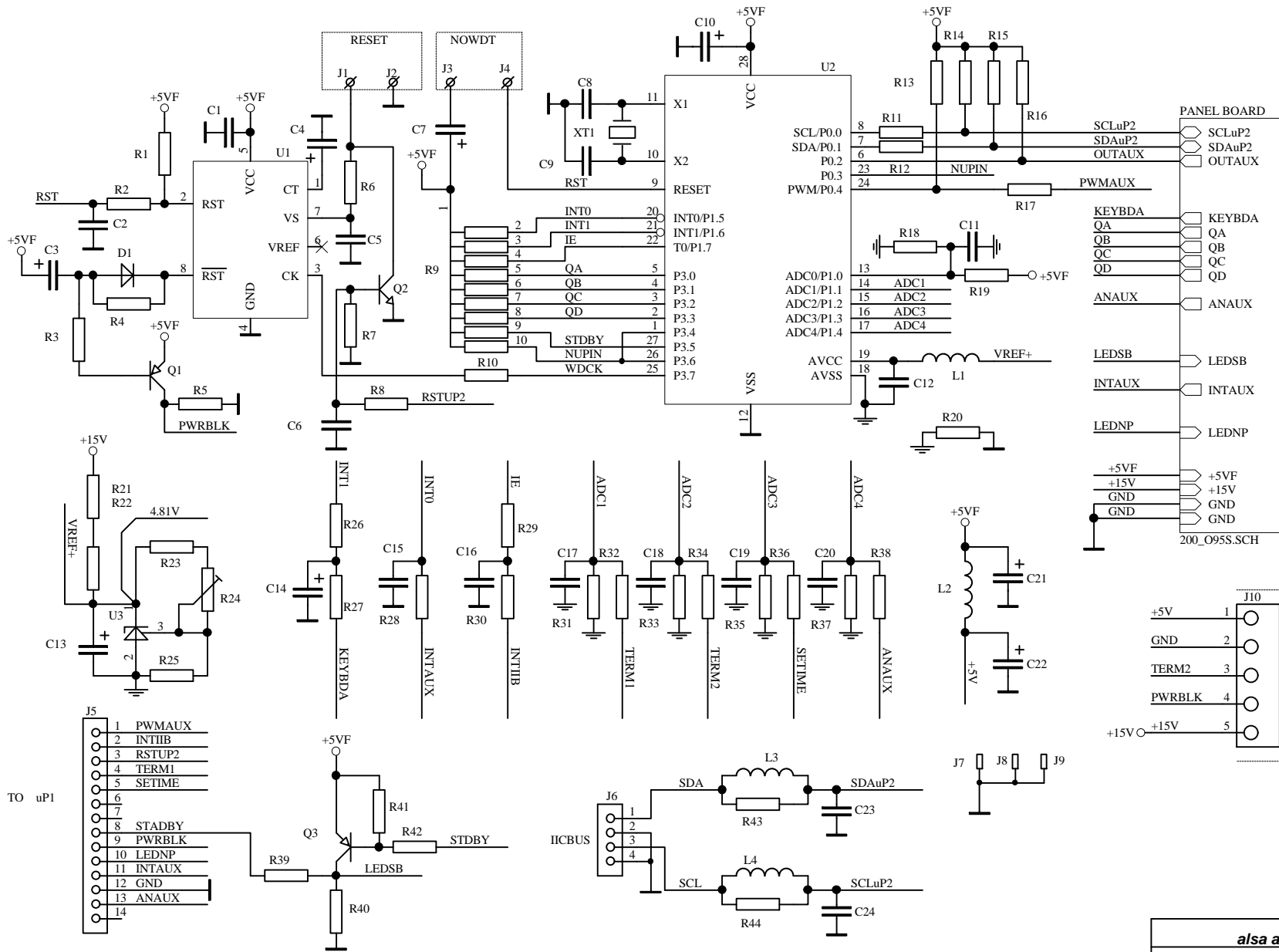

alsa apparecchi medicali s.r.l.		
EXCELL MCDS mod. 200 - 350		
BIS_095R - Sezione uP2		
alsa code: 801326	Rev.: 4.1	3/Dec/98
Drawn by:		Approval:



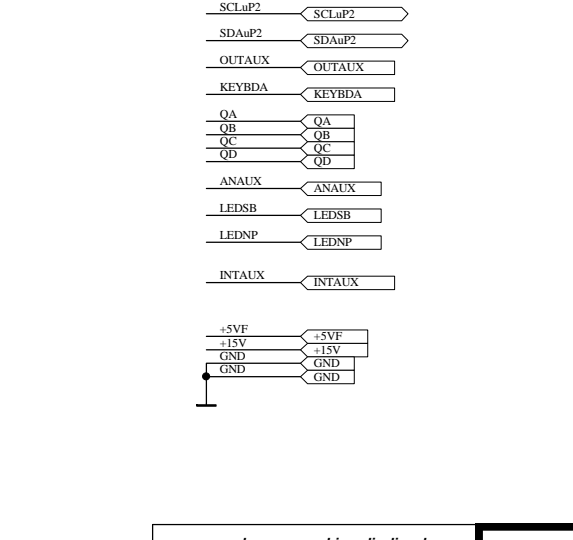
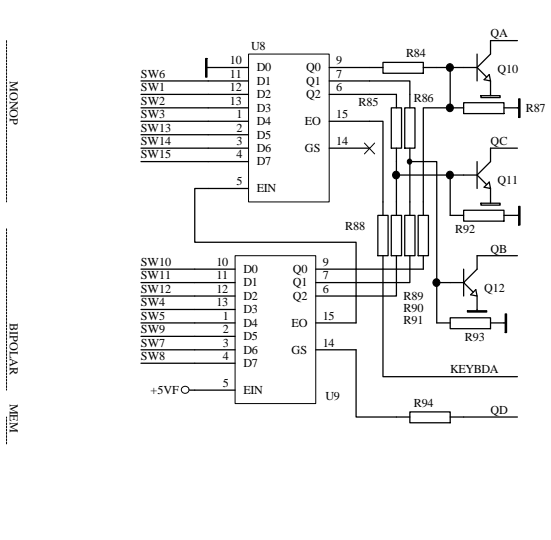
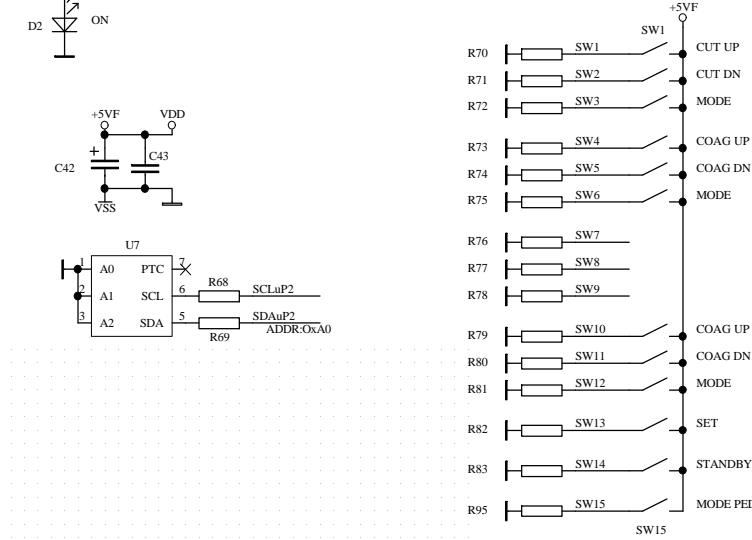
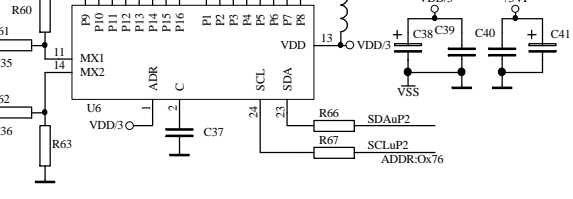
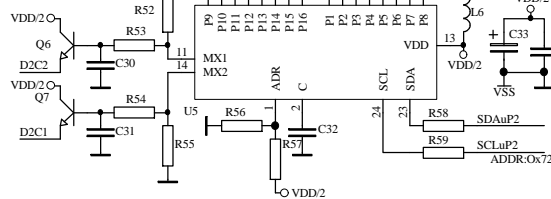
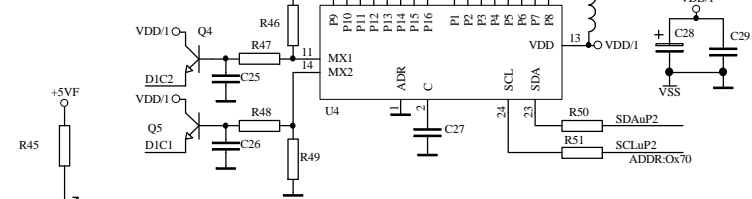
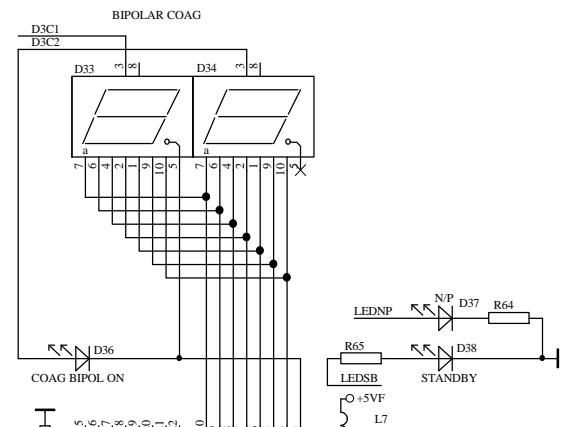
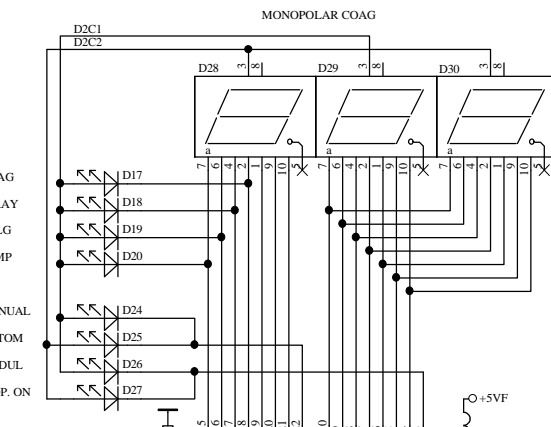
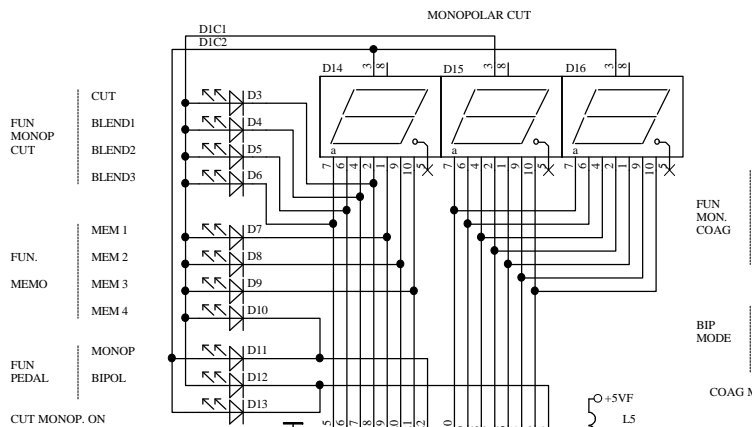

alsa apparecchi medicali s.r.l.		alsa botogna
EXCELL MCDS mod. 200 - 350		
BIS O95S - Display e Pannello Comandi		
alsa code: 801326 Rev.: 4.1B 4/Dec/98		
Drawn by:	Approval:	

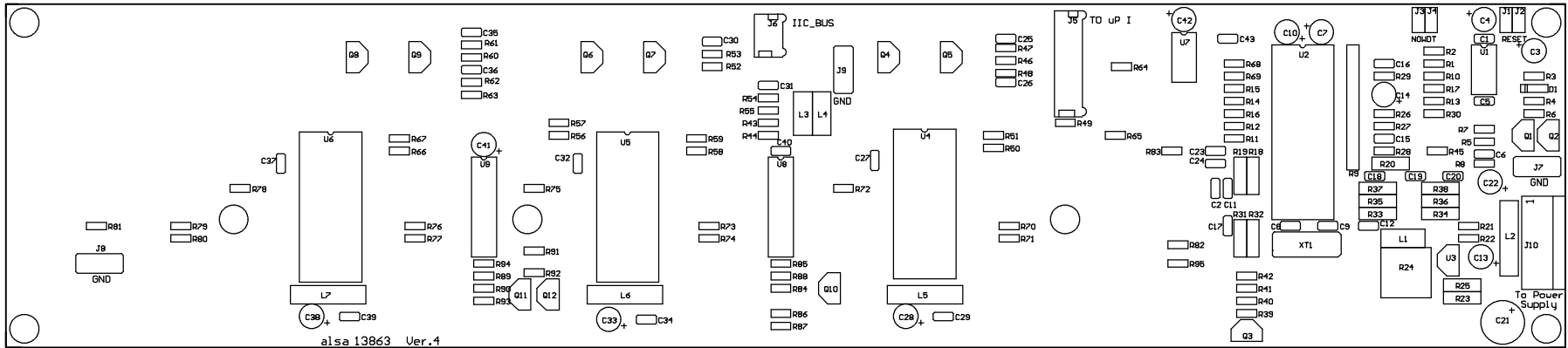

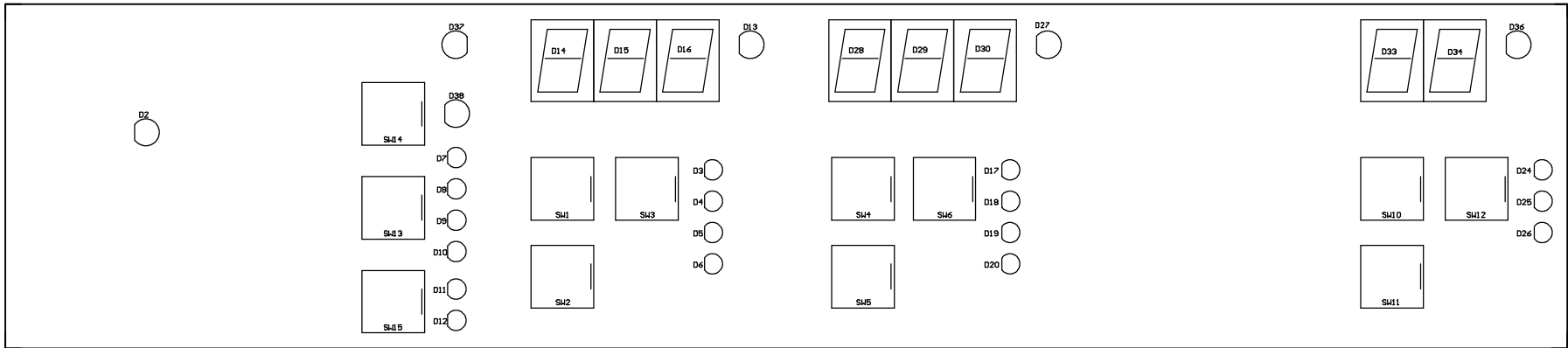

ELECTROSURGICAL UNIT EXCELL 200 MCDS- 350 MCDS**PANEL BOARD****alsa code: 801326 Rev.: 4.1****Last revised: 3-dec-98 Date: 12-gen-00 13.27**

Reference	Part Type	Description	alsa code
R1	10K	METAL FILM RESISTOR 1/4 W 5%	430339
R2	100	METAL FILM RESISTOR 1/4 W 5%	430336
R3	10K	METAL FILM RESISTOR 1/4 W 5%	430339
R4	10K	METAL FILM RESISTOR 1/4 W 5%	430339
R5	1K5	METAL FILM RESISTOR 1/4 W 5%	430199
R6	1K	METAL FILM RESISTOR 1/4 W 5%	430170
R7	4K7	METAL FILM RESISTOR 1/4 W 5%	430167
R8	10K	METAL FILM RESISTOR 1/4 W 5%	430339
R9	X_RNET10K	RESISTOR NETWORK 10K	430484
R10	1K	METAL FILM RESISTOR 1/4 W 5%	430170
R11	220	METAL FILM RESISTOR 1/4 W 5%	430358
R12	220	METAL FILM RESISTOR 1/4 W 5%	430358
R13	10K	METAL FILM RESISTOR 1/4 W 5%	430339
R14	10K	METAL FILM RESISTOR 1/4 W 5%	430339
R15	10K	METAL FILM RESISTOR 1/4 W 5%	430339
R16	10K	METAL FILM RESISTOR 1/4 W 5%	430339
R17	100	METAL FILM RESISTOR 1/4 W 5%	430336
R18	3K/1%	PRECISION RESISTOR 1% 0.6W	430459
R19	3K/1%	PRECISION RESISTOR 1% 0.6W	430459
R20	0/0	0 OHM RESISTOR	430446
R21	470	METAL FILM RESISTOR 1/4 W 5%	430169
R22	470	METAL FILM RESISTOR 1/4 W 5%	430169
R23	1270/1%	PRECISION RESISTOR 1% 0.6W	430492
R24	5KT	PRESET POTENTIOMETER CERMET	403052
R25	4120/1%	PRECISION RESISTOR 1% 0.6W	430483
R26	100	METAL FILM RESISTOR 1/4 W 5%	430336
R27	100	METAL FILM RESISTOR 1/4 W 5%	430336
R28	100	METAL FILM RESISTOR 1/4 W 5%	430336
R29	100	METAL FILM RESISTOR 1/4 W 5%	430336
R30	1K	METAL FILM RESISTOR 1/4 W 5%	430170
R31	11K/1%	PRECISION RESISTOR 1% 0.6W	430467
R32	1K/1%	PRECISION RESISTOR 1% 0.6W	430458
R33	11K/1%	PRECISION RESISTOR 1% 0.6W	430467
R34	1K/1%	PRECISION RESISTOR 1% 0.6W	430458
R35	11K/1%	PRECISION RESISTOR 1% 0.6W	430467
R36	1K/1%	PRECISION RESISTOR 1% 0.6W	430458
R37	11K/1%	PRECISION RESISTOR 1% 0.6W	430467
R38	1K/1%	PRECISION RESISTOR 1% 0.6W	430458
R39	100	METAL FILM RESISTOR 1/4 W 5%	430336
R40	470	METAL FILM RESISTOR 1/4 W 5%	430169
R41	22K	METAL FILM RESISTOR 1/4 W 5%	430179
R42	2K2	METAL FILM RESISTOR 1/4 W 5%	430343
R43	1K	METAL FILM RESISTOR 1/4 W 5%	430170
R44	1K	METAL FILM RESISTOR 1/4 W 5%	430170
R45	560	METAL FILM RESISTOR 1/4 W 5%	430178
R46	1K	METAL FILM RESISTOR 1/4 W 5%	430170
R47	100	METAL FILM RESISTOR 1/4 W 5%	430336
R48	100	METAL FILM RESISTOR 1/4 W 5%	430336
R49	1K	METAL FILM RESISTOR 1/4 W 5%	430170
R50	220	METAL FILM RESISTOR 1/4 W 5%	430358
R51	220	METAL FILM RESISTOR 1/4 W 5%	430358
R52	1K	METAL FILM RESISTOR 1/4 W 5%	430170
R53	100	METAL FILM RESISTOR 1/4 W 5%	430336
R54	100	METAL FILM RESISTOR 1/4 W 5%	430336
R55	1K	METAL FILM RESISTOR 1/4 W 5%	430170
R56	10K	METAL FILM RESISTOR 1/4 W 5%	430339
R57	15K	METAL FILM RESISTOR 1/4 W 5%	430345
R58	220	METAL FILM RESISTOR 1/4 W 5%	430358

Reference	Part Type	Description	alsa code
R59	220	METAL FILM RESISTOR 1/4 W 5%	430358
R60	1K	METAL FILM RESISTOR 1/4 W 5%	430170
R61	100	METAL FILM RESISTOR 1/4 W 5%	430336
R62	100	METAL FILM RESISTOR 1/4 W 5%	430336
R63	1K	METAL FILM RESISTOR 1/4 W 5%	430170
R64	330	METAL FILM RESISTOR 1/4 W 5%	430171
R65	330	METAL FILM RESISTOR 1/4 W 5%	430171
R66	220	METAL FILM RESISTOR 1/4 W 5%	430358
R67	220	METAL FILM RESISTOR 1/4 W 5%	430358
R68	220	METAL FILM RESISTOR 1/4 W 5%	430358
R69	220	METAL FILM RESISTOR 1/4 W 5%	430358
R70	1K8	METAL FILM RESISTOR 1/4 W 5%	430198
R71	1K8	METAL FILM RESISTOR 1/4 W 5%	430198
R72	1K8	METAL FILM RESISTOR 1/4 W 5%	430198
R73	1K8	METAL FILM RESISTOR 1/4 W 5%	430198
R74	1K8	METAL FILM RESISTOR 1/4 W 5%	430198
R75	1K8	METAL FILM RESISTOR 1/4 W 5%	430198
R76	1K8	METAL FILM RESISTOR 1/4 W 5%	430198
R77	1K8	METAL FILM RESISTOR 1/4 W 5%	430198
R78	1K8	METAL FILM RESISTOR 1/4 W 5%	430198
R79	1K8	METAL FILM RESISTOR 1/4 W 5%	430198
R80	1K8	METAL FILM RESISTOR 1/4 W 5%	430198
R81	1K8	METAL FILM RESISTOR 1/4 W 5%	430198
R82	1K8	METAL FILM RESISTOR 1/4 W 5%	430198
R83	1K8	METAL FILM RESISTOR 1/4 W 5%	430198
R84	22K	METAL FILM RESISTOR 1/4 W 5%	430179
R85	22K	METAL FILM RESISTOR 1/4 W 5%	430179
R86	22K	METAL FILM RESISTOR 1/4 W 5%	430179
R87	22K	METAL FILM RESISTOR 1/4 W 5%	430179
R88	100	METAL FILM RESISTOR 1/4 W 5%	430336
R89	22K	METAL FILM RESISTOR 1/4 W 5%	430179
R90	22K	METAL FILM RESISTOR 1/4 W 5%	430179
R91	22K	METAL FILM RESISTOR 1/4 W 5%	430179
R92	22K	METAL FILM RESISTOR 1/4 W 5%	430179
R93	22K	METAL FILM RESISTOR 1/4 W 5%	430179
R94	100	METAL FILM RESISTOR 1/4 W 5%	430336
R95	1K8	METAL FILM RESISTOR 1/4 W 5%	430198
C1	100n	CERAMIC CAPACITOR	400139
C2	100n	CERAMIC CAPACITOR	400139
C3	10u/T/35V	TANTALUM ELECTROLYTIC CAPACITOR	400134
C4	1U/T/35V	TANTALUM ELECTROLYTIC CAPACITOR	400173
C5	100n	CERAMIC CAPACITOR	400139
C6	10n	CERAMIC CAPACITOR	400251
C7	10u/T/35V	TANTALUM ELECTROLYTIC CAPACITOR	400134
C8	22p/C	CERAMIC CAPACITOR	400290
C9	22p/C	CERAMIC CAPACITOR	400290
C10	10u/T/35V	TANTALUM ELECTROLYTIC CAPACITOR	400134
C11	100n	CERAMIC CAPACITOR	400139
C12	10n	CERAMIC CAPACITOR	400251
C13	10u/T/35V	TANTALUM ELECTROLYTIC CAPACITOR	400134
C14	1U/T/35V	TANTALUM ELECTROLYTIC CAPACITOR	400173
C15	100n	CERAMIC CAPACITOR	400139
C16	100n	CERAMIC CAPACITOR	400139
C17	100n	CERAMIC CAPACITOR	400139
C18	100n	CERAMIC CAPACITOR	400139
C19	100n	CERAMIC CAPACITOR	400139
C20	100n	CERAMIC CAPACITOR	400139
C21	47u/E/50V	ELECTROLYTIC CAPACITOR	400296
C22	10u/T/35V	TANTALUM ELECTROLYTIC CAPACITOR	400134
C23	100p/NPO	NPO CERAMIC CAPACITOR	400260
C24	100p/NPO	NPO CERAMIC CAPACITOR	400260
C25	1N/C	CERAMIC CAPACITOR	400252

Reference	Part Type	Description	alsa code
C26	1N/C	CERAMIC CAPACITOR	400252
C27	2n2/C	CERAMIC CAPACITOR	400261
C28	10u/T/35V	TANTALUM ELECTROLYTIC CAPACITOR	400134
C29	100n	CERAMIC CAPACITOR	400139
C30	1N/C	CERAMIC CAPACITOR	400252
C31	1N/C	CERAMIC CAPACITOR	400252
C32	2n2/C	CERAMIC CAPACITOR	400261
C33	10u/T/35V	TANTALUM ELECTROLYTIC CAPACITOR	400134
C34	100n	CERAMIC CAPACITOR	400139
C35	1N/C	CERAMIC CAPACITOR	400252
C36	1N/C	CERAMIC CAPACITOR	400252
C37	2n2/C	CERAMIC CAPACITOR	400261
C38	10u/T/35V	TANTALUM ELECTROLYTIC CAPACITOR	400134
C39	100n	CERAMIC CAPACITOR	400139
C40	100n	CERAMIC CAPACITOR	400139
C41	10u/T/35V	TANTALUM ELECTROLYTIC CAPACITOR	400134
C42	10u/T/35V	TANTALUM ELECTROLYTIC CAPACITOR	400134
C43	100n	CERAMIC CAPACITOR	400139
D1	1N4148	DIODE	420010
D2	GL5HG8	GREEN LED LAMP 5MM	420037
D3	LEDG3	GREEN LED LAMP 3MM	420079
D4	LEDG3	GREEN LED LAMP 3MM	420079
D5	LEDG3	GREEN LED LAMP 3MM	420079
D6	LEDG3	GREEN LED LAMP 3MM	420079
D7	LEDG3	GREEN LED LAMP 3MM	420079
D8	LEDG3	GREEN LED LAMP 3MM	420079
D9	LEDG3	GREEN LED LAMP 3MM	420079
D10	LEDG3	GREEN LED LAMP 3MM	420079
D11	LEDG3	GREEN LED LAMP 3MM	420079
D12	LEDG3	GREEN LED LAMP 3MM	420079
D13	GL5HY8	YELLOW LED LAMP 5MM	420036
D14	HDSP5501	HIGH EFFICIENCY 7 SEGMENT DISPLAY	420080
D15	HDSP5501	HIGH EFFICIENCY 7 SEGMENT DISPLAY	420080
D16	HDSP5501	HIGH EFFICIENCY 7 SEGMENT DISPLAY	420080
D17	LEDG3	GREEN LED LAMP 3MM	420079
D18	LEDG3	GREEN LED LAMP 3MM	420079
D19	LEDG3	GREEN LED LAMP 3MM	420079
D20	LEDG3	GREEN LED LAMP 3MM	420079
D24	LEDG3	GREEN LED LAMP 3MM	420079
D25	LEDG3	GREEN LED LAMP 3MM	420079
D26	LEDG3	GREEN LED LAMP 3MM	420079
D27	GL5HB8	BLUE LED LAMP 5MM	420092
D28	HDSP5501	HIGH EFFICIENCY 7 SEGMENT DISPLAY	420080
D29	HDSP5501	HIGH EFFICIENCY 7 SEGMENT DISPLAY	420080
D30	HDSP5501	HIGH EFFICIENCY 7 SEGMENT DISPLAY	420080
D33	HDSP5501	HIGH EFFICIENCY 7 SEGMENT DISPLAY	420080
D34	HDSP5501	HIGH EFFICIENCY 7 SEGMENT DISPLAY	420080
D36	GL5HB8	BLUE LED LAMP 5MM	420092
D37	GL5HR8	RED LED LAMP 5MM	420025
D38	GL5HO8	INTERMITTENT 5MM LED LAMP	420093
Q1	BC557	PNP TRANSISTOR	427058
Q2	BC237B	NPN TRANSISTOR	427057
Q3	BC557	PNP TRANSISTOR	427058
Q4	BC237B	NPN TRANSISTOR	427057
Q5	BC237B	NPN TRANSISTOR	427057
Q6	BC237B	NPN TRANSISTOR	427057
Q7	BC237B	NPN TRANSISTOR	427057
Q8	BC237B	NPN TRANSISTOR	427057
Q9	BC237B	NPN TRANSISTOR	427057
Q10	BC237B	NPN TRANSISTOR	427057
Q11	BC237B	NPN TRANSISTOR	427057
Q12	BC237B	NPN TRANSISTOR	427057

Reference	Part Type	Description	alsa code
L1	100uH/275mA	INDUCTOR	422006
L2	6UH8/800mA	INDUCTOR	422007
L3	100uH/275mA	INDUCTOR	422006
L4	100uH/275mA	INDUCTOR	422006
L5	6UH8/800MA	INDUCTOR	422007
L6	6UH8/800MA	INDUCTOR	422007
L7	6UH8/800MA	INDUCTOR	422007
U1	MB3773	WATCH-DOG TIMER	482088
U2	87C752_MCDS	12 MHZ MICROCONTROLLER (PROGR.)	713921
U3	LM431	VOLTAGE REGULATOR	482078
U4	SAA1064	DISPLAY DECODER	482080
U5	SAA1064	DISPLAY DECODER	482080
U6	SAA1064	DISPLAY DECODER	482080
U7	PCF8582	EEPROM I ² _CBUS PHILIPS	482083
U8	4532	ENCODER 8 BIT	482081
U9	4532	ENCODER 8 BIT	482081
XT1	12Mhz/HC18	QUARTZ CRYSTAL 12 MHZ	252005
SW1	MTG_1241	PUSHBUTTON SCHURTER	416094
SW2	MTG_1241	PUSHBUTTON SCHURTER	416094
SW3	MTG_1241	PUSHBUTTON SCHURTER	416094
SW4	MTG_1241	PUSHBUTTON SCHURTER	416094
SW5	MTG_1241	PUSHBUTTON SCHURTER	416094
SW6	MTG_1241	PUSHBUTTON SCHURTER	416094
SW10	MTG_1241	PUSHBUTTON SCHURTER	416094
SW11	MTG_1241	PUSHBUTTON SCHURTER	416094
SW12	MTG_1241	PUSHBUTTON SCHURTER	416094
SW13	MTG_1241	PUSHBUTTON SCHURTER	416094
SW14	MTG_1241	PUSHBUTTON SCHURTER	416094
SW15	MTG_1241	PUSHBUTTON SCHURTER	416094
J1	PAD_CI	PAD	-----
J2	PAD_CI	PAD	-----
J3	PAD_CI	PAD	-----
J4	PAD_CI	PAD	-----
J5	PICO_14	14 POLES PICO FLEX CONN. MALE P.C.B.	384040
J6	PICO_4	4 POLES PICO FLEX CONN. MALE P.C.B.	384042
J7	399028	FASTON CONNECTOR P.C.B.	399028
J8	399028	FASTON CONNECTOR P.C.B.	399028
J9	399028	FASTON CONNECTOR P.C.B.	399028
J10	384016	5 POLES PCB CONNECTOR MASCON	384016

EXCELL 200/250/350/400 MCDS

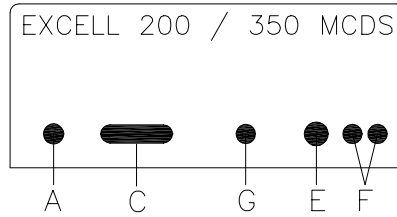
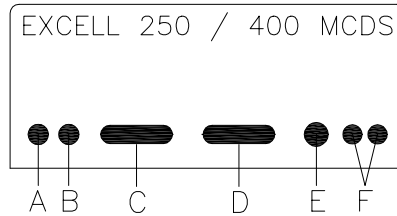
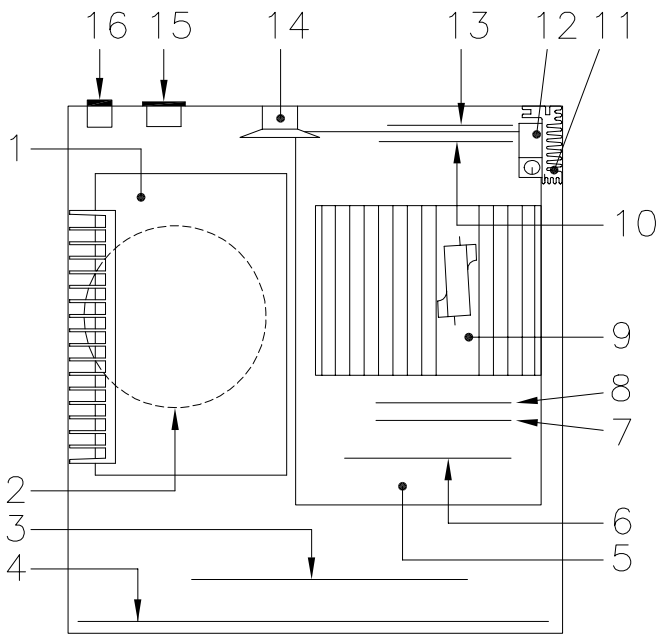

- 1) 801301: Power Supply Board
- 2) 801324: Trasformatore / Transformer
- 3) 801309: Double Switch Handle Board
- 4) 801310: Panel Board (Excell 250/400 MCDS)
801326: Panel Board (Excell 200/350 MCDS)
- 5) 801302: Mother Board
- 6) 801308: Double Handle and Neutral Plate Control Board
- 7) 801306: Power Reader Board 1
- 8) 801307: Power Reader Board 2
- 9) 801305: RF Power Board
- 10) 801303: Microcontroller Board
- 11) 713911: Dissipatore termico / Heat sink
- 12) 430486: Resistenza 150 ohm / 150 ohm resistor
- 13) 801304: RF Driver Board
- 14) 449125: Altoparlante / Loud speaker
- 15) 437029: Presa di rete / Power entry module
- 16) 416090: Interruttore di rete / Mains switch



A) Presa pedale / Pedal socket
384030: Presa a 3 poli / 3 pins socket



B) Presa pedale (Solo per sezione bipolare) / Pedal socket (only for bipolar section)
384028: Presa a 7 poli / 7 pins socket

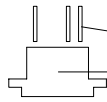

C) Presa attiva (solo per manici con comando manuale) / Socket (only for hand-switch handles)
712880: Inserto metallico (3 pz.) / Brass part (3 pcs)
703279: Corpo plastico / Plastic part

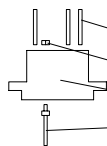

D) Presa attiva (per manici con comando a pedale e manuale) / Socket (for hand-switch or foot-switch handles)
712880: Inserto metallico (3 pz.) / Brass part (3 pcs)
325021: Dado M4 / M4 nut
703279: Corpo plastico / Plastic part
438031: Spinotto Ø 4 / Ø 4 mm plug

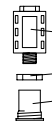

E) Presa piastra neutra / Neutral plate socket
437032: Presa jack / Panel jack socket
496020: Dado 1/2 G / 1/2 G nut
713604: Corpo plastico / Plastic part

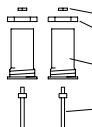

F) Presa bipolare (2 pz.) / Bipolar socket (2 pcs)
701364: Dado M2 / M2 nut
496027: Dado 3/8 G / 3/8 G nut
713897: Corpo plastico / Plastic part
438048: Spinotto Ø 2 / Ø 2 plug

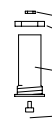

G) Presa manipolo-pedale / foot-switch handle socket
325021: Dado M4 / M4 nut
496027: Dado 3/8 G / 3/8 G nut
713653: Corpo plastico / Plastic part
438031: Spinotto Ø 4 / Ø 4 mm plug

EXCELL MCDS SERIES WIRINGS CONNECTIONS

