



# COLD POINT CORPORATION

Cold Point Corporation, Rome, New York 13440 Phone (315)339-2331 Fax (315)339-2358 Web: www.COLDPOINTCORP.com



## Replacement Chassis

# Installation Operation and Maintenance



Thank You for choosing COLD POINT products! We have designed and manufactured this unit to be safe and trouble free. As the installer of this unit, you play a major role in assuring it's intended performance and customer satisfaction. The important information provided here will help you install the unit correctly and eliminate call-backs. If you are in need of assistance that is not available or provided by your local installer/contractor feel free to write, call, fax or e-mail us at:

Cold Point Corp.  
7500 Cold Point Dr.  
Rome, NY 13440  
Phone:315.339.2331  
Fax: 315.339.2358  
e-mail: info@coldpointcorp.com

**Retain this manual for future reference. A copy should be left on premises with the maintenance and/or administrative department at the property.**

### '5QT' PRODUCT DESCRIPTION:

*Cold Point '5QT' Series* is direct replacement for *Carrier '50QT' series* 1½ & 2-ton reverse cycle defrost heat pump chassis. The chassis is a part of a complete system, which consists of the chassis, a wall sleeve/cabinet with louver that is typically built into the building exterior wall, ductwork, and wall thermostat. The chassis contains the compressor, indoor and outdoor heat exchangers, evaporator and condenser motors and fans, electric heaters, and all controls with exception of the wall thermostat. The chassis slides into the sleeve/cabinet for easy removal. The new chassis is **dimensionally identical** to the original for a fast, easy, and trouble free installation. Proven technology, quality components, careful design and testing, and the latest in reliability and efficiency advances assure long life, user satisfaction, and lower energy cost! These **full-range heat pump** units with **reverse cycle defrost** include: **bi-flow thermostatic expansion valve**, oversized **suction accumulator**, **electronic defrost** control, compressor **crankcase heater**, built-in **electric heaters** with

overheat protection, high efficiency 'PSC' evaporator and condenser **blower motors** & dynamically balanced **DWDI blower wheels**. Also standard are: **Rust-Block\*** corrosion protection system, evaporator **freeze protection**, **high-pressure over protection**, and

**lockout circuit.** *Cold Point Corp.* backs the '5QT' with a customer friendly **one-year parts and labor warranty** and **five-year compressor warranty**, (see *Warranty* document for details).

FIG. 1

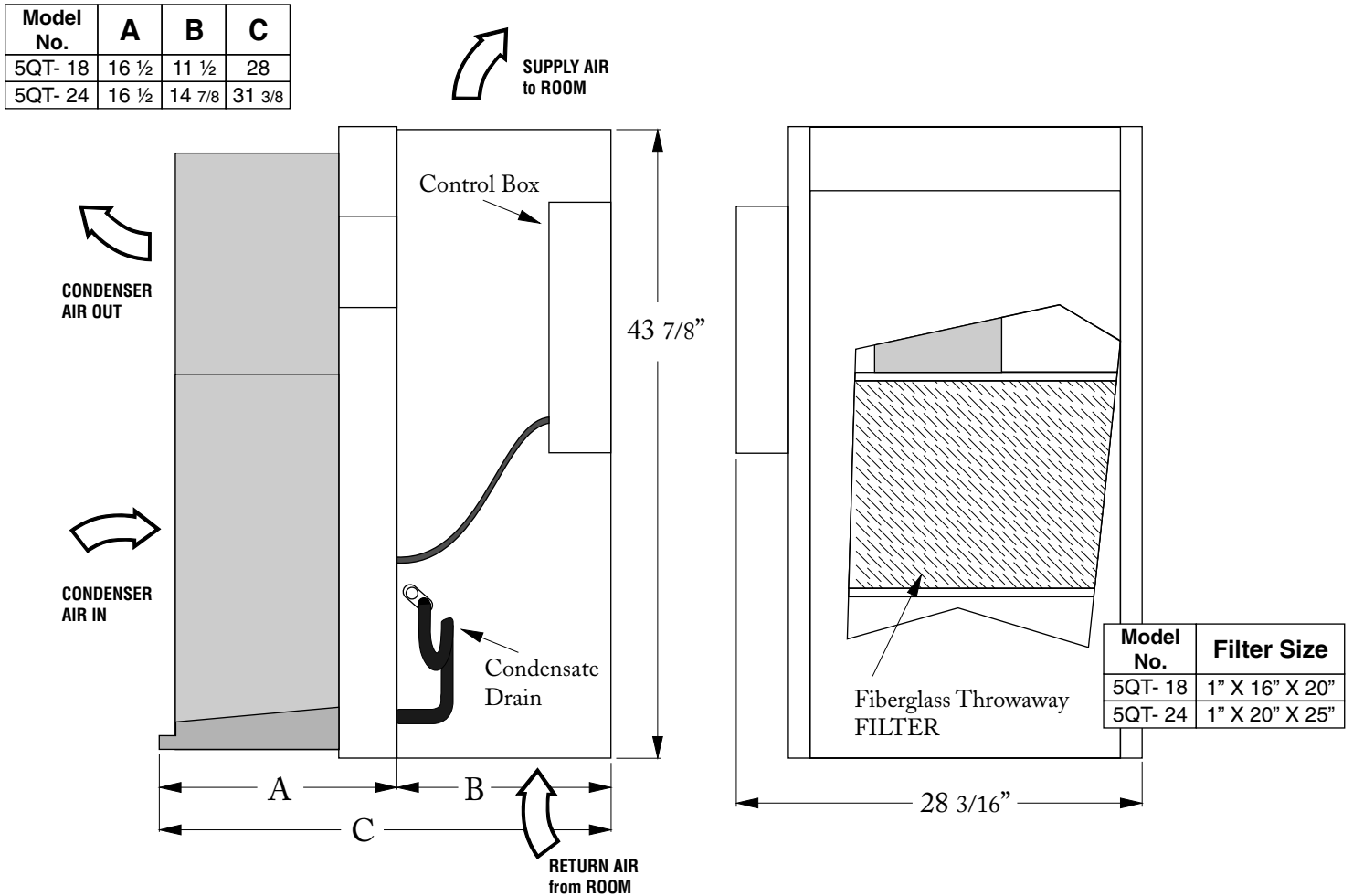

**5QT- Packaged Heat Pump Electrical Specifications**

Model No.	Voltage HZ/PH.	Comp. RLA	Comp. LRA	Evap. Mtr. HP	Evap. Mtr. AMPS	Cond. Mtr. HP	Cond. Mtr. AMPS	Total Amps	Min. CKT Ampacity	Max Fuse Size	Min Volts
5QT- 18	208/230/60/1	7.4	48.0	1/5	1.3	1/4	1.4	10.1	12	15	197
5QT- 24	208/230/60/1	9.6	60.0	1/5	1.3	1/4	1.4	12.3	15	20	197

**5QT- Electric Heat Pump Electrical Specifications**

Model No.	Voltage HZ/PH.	KW	Heater AMPS	Min. CKT Ampacity	Max Fuse Size
5QT- 18	208/230/60/1	7.8/9.6	37.5/41.8	47/53	50A/50A
5QT- 24					

**5QT- Packaged Heat Pump Performance Ratings\***

Model No.	Cooling		Heating		Comp. Type
	BTU/h	EER	BTU/h	COP	
5QT- 18	20,000	9.9	20,000	3.4	Recip.
5QT- 24	24,000	8.9	24,500	3.2	Recip.

\*Rated in Accordance with ARI

## GENERAL:

These instructions give information relative to COLD POINT '5QT' model units. Local codes, if different from these instructions, must be followed and supplement or supersede these instructions.

## UNPACKING AND INSPECTION:

The 5QT chassis is shipped completely assembled and in its own package. The exterior louver (optional) is shipped separately. The wall thermostat (optional) is shipped inside the chassis. All goods are inspected at the factory and released to the freight company in good condition. When received at the site, a visual inspection of all packages should be made immediately. Any evidence of rough handling or apparent damage should be noted on the delivery receipt and the material inspected in the presence of the carrier's representative. If damage is found a claim should be filed with the freight company immediately.

**Filter MUST be cleaned periodically for parts warranty to be in effect**

**"USE ON SINGLE OUTLET CIRCUIT ONLY."**

**"CAUTION"  
RISK OF ELECTRICAL SHOCK. DISCONNECT POWER BEFORE SERVICING UNIT.**

**"CAUTION"  
MOVING PARTS. DO NOT OPERATE UNIT WITH SERVICE PANEL REMOVED**

**CAUTION!!**

CONTAINS REFRIGERANT. SYSTEM CONTAINS OIL AND REFRIGERANT UNDER HIGH PRESSURE. RECOVER REFRIGERANT TO RELIEVE PRESSURE BEFORE OPENING THE SYSTEM. FAILURE TO FOLLOW PROPER PROCEDURES CAN RESULT IN PERSONAL ILLNESS OR INJURY OR SEVERE DAMAGE TO EQUIPMENT.

**CAUTION!!**

TO PREVENT AIR BY-PASS AND COIL FROSTING THIS PANEL MUST BE IN PLACE AT ALL TIMES.

## JOB SITE STORAGE:

These units are intended for in-wall use only. To protect the unit from damage due to the elements and prevent it from possibly becoming a contaminant source of IAQ problems, the unit should be stored indoors. If indoor storage is not possible, the following provisions must be met:

1. Place the unit on a dry surface or raise off the ground to assure adequate air circulation beneath the unit and to assure that no

portion of the unit contact standing water at any time.

2. Cover the unit with a water repellant tarp to protect them from the elements
3. Make provisions for continuous venting of the covered unit to prevent moisture from condensing on the unit surfaces.

## PRE-INSTALLATION SAFETY INSTRUCTIONS

**Failure to follow these instructions can result in fire or electrical shock causing serious personal injury or death and property damage.**

- Read all instructions carefully before proceeding with the installation. Keep this manual for future reference.
- Install or locate the unit only in accordance with these instructions.
- Use this unit only for its intended purpose as described in this manual.
- Check the rating plate on the new unit before installation to make certain the unit voltage is the same as the electrical supply. Do not proceed if there is a discrepancy.
- The unit must be connected to a properly grounded electrical supply. Failure to do so will cause a serious safety hazard!
- The use of extension cords is prohibited.
- Electrical supply must have overload fuse/breaker protection as stated on unit rating plate.
- Turn off the electrical supply before beginning the installation or before service panels are removed!
- Stop the installation if unit has damaged wiring, is not working properly, or has been damaged or dropped.

## !IMPORTANT! ALTERATIONS AND REPLACEMENT PARTS:

**Altering the product or replacing parts with non authorized factory parts will void the factory warranty and may result in adverse operational performance and / or a possible hazardous safety condition to service personnel and occupants. If you are in doubt as to how to service this unit or where to find factory replacement parts, call Cold Point Corp. @ 315.339.2331 for assistance.**

## IMPORTANT INSTALLATION CONSIDERATIONS:

The installation must comply with all of the following considerations. Any deficiencies must be corrected before completing the installation! Failure to comply will create unsafe and/or performance and service life problems and will void the product warranty.

- All wiring must comply with 'NEC' and local codes.
- Carpet, furniture, or other obstructions that will hinder free airflow to the unit must not block the return air.
- Shrubs, plants, fences, or structures must not obstruct outdoor airflow. Building modifications or structures must not block or obstruct free airflow to the outdoor section of the unit. Units must not be positioned such that the discharge air of one unit blows to the inlet of an adjacent unit.
- Outdoor air infiltration around the wall sleeve and chassis must be sealed. Failure to do so will overload the room and may result in comfort and energy cost problems.

## REMOVAL OF OLD CHASSIS:

- Locate power supply (breaker box) to unit.  
IMPORTANT: Determine how many breakers were used to power unit. Some units were powered using individual breakers for the electric heat and compressor circuits or a single breaker for both circuits.
- Disconnect the power supply by turning off the power at circuit breaker panel. Be sure to tag or lock the breaker(s) to prevent accidental or inadvertent re-energizing of circuit.
- Remove front wrapper cover to gain access to chassis. Remove all necessary hardware to separate chassis from wall sleeve. Slide chassis out from wall sleeve.

## BEFORE INSTALLING NEW CHASSIS:

- Inspect the condition of weather seal gaskets for shipping damage. Repair or replace if needed.
- Inspect the condition of wall sleeve. Repair if needed.  
**Check and clean drain in wall sleeve.**
- **IMPORTANT: Remove and save evaporator coil drain/trap hose, to be used on new chassis.** (see FIG. 1 on pg. 2)
- Verify Louver Type.
  - Stamped Louver- Replace with Cold Point Louver.
  - Aluminum Louver- Remove Baffle

Remove Baffle



**ALUMINUM LOUVER**



**STAMPED LOUVER  
(REPLACE)**

To reinstall unit, reverse the procedure outlined above. Always check to see that the chassis is sealed to the wall sleeve to prevent water and air leakage. Replace or add seals as needed.

**CAUTION** - Always replace access panels before turning on main power.

## ELECTRICAL WIRING:

NOTE: All electrical wiring must be done by a qualified electrician and in accordance with NEC and local codes.

The original Carrier chassis was installed using an electrical plug type connector, between the chassis control box and junction box mounted to wall sleeve. This will be the case for most of the existing installations. To adapt to the original installation remove the female electrical connector from the junction box mounted to wall sleeve. Run a power supply from the existing junction box to terminal block on the 5QT chassis.

In some cases you will find a disconnect box mounted inside of a closet or utility room wall. With this type of installation you can run the main power from the disconnect box directly to the terminal block on the new chassis.

The nameplate on the new chassis indicates the operating voltage, phase, ampacity, maximum over-current protection, and minimum voltage. The power supply must be in accordance with these requirements! Use only HACR type circuit breakers. Inadequate wiring and/or improper electrical supply can cause a safety hazard and/or fire and will likely result in failure of the compressor and other electrical components and voids the warranty. The use of an extension cord is not allowed.

The 5QT was designed to be wired using a single or double breaker system, depending on how the existing unit was wired. On a single breaker system, you will need to install jumper wires (supplied with each unit) at

the terminal block. With a double breaker system, both the compressor and electric heat will be wired separately at terminal block (see FIG. 2). All low volt connections will be made at defrost board.

**FIELD WIRING:**  
USE (E) TERMINAL ON DEFROST BOARD FOR (G) CONNECTION

**FIG. 2**

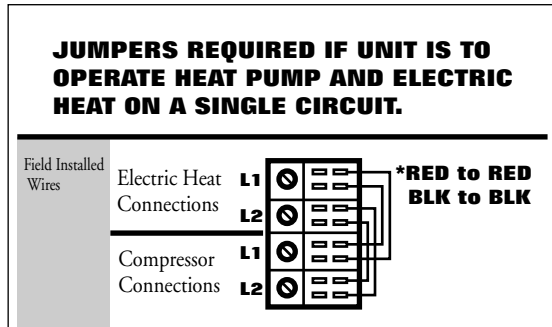

**START-UP, RUN TEST, and OPERATING INSTRUCTIONS:**

**CRANKCASE HEATER:** The 5QT is equipped with a crankcase heater. If the temperature is below 65°F, operate the crankcase heater 24 hours before starting unit.

Time spent to assure proper operation will eliminate call-backs and is time well spent to assure customer satisfaction.

COLD POINT 5QT series units are designed to operate from wall mounted thermostats of various designs including mechanical, mercury bulb, and electronic types. The following are general guidelines. Refer to the specific thermostat instructions, and unit wiring diagram for more detail.

**Note that many electronic thermostats have built in time delay circuitry. These features will affect the on-off timing of the cooling, heat pump, and fan operation. Some thermostats have programmable features. Refer to the thermostat instruction sheets for details of these various functions.**

**HEATING OPERATION:  
(HEAT PUMP with ELECTRIC HEAT)**

\*Recommend using 2-Stage thermostat.

- Set thermostat system switch to Heat.
- Set thermostat fan switch to Auto.
- Set the thermostat temperature to a setting warmer than the room temperature.
- The compressor, condenser fan and evaporator fan will run during heating cycle and produce warm air.

- If thermostat calls for 2nd stage heat, both heat pump and electric heat will run.
- The unit will continue to run until thermostat is satisfied.

**DEFROST CYCLE:**

- While running in heat pump mode if the defrost thermostat senses a temperature of 30°F, the interval between defrost will begin 30/60/90 min. (factory set at 60min.)
- At the end of 60 min. run time the condenser fan will stop and the unit will reverse cycle to cooling and electric heat will energize.
- The unit will continue to run in this mode until the defrost thermostat reaches 80°F or 10min., which ever is satisfied first.

- Unit will resume normal heating operation.

Note: Under certain conditions steam may be seen emanating from the outdoor section during defrost. This is a normal by product of frost elimination.

**COOLING OPERATION:**

- Set thermostat system switch to Cooling.
- Set thermostat fan switch to Auto.
- Set the thermostat temperature to a setting lower than room temperature.
- The compressor, condenser fan and evaporator fan will run during cooling cycle and produce cool air.
- The unit will continue to run until thermostat is satisfied.

**FINAL INSPECTION:**

Do a final visual inspection of the entire installation and confirm the following:

- The unit is clean and all tools and construction debris have been picked up.
- Room furnishings, carpets, and the like have been replaced in their original position.
- All controls and protective devices function properly.
- The unit air filter is properly installed.
- The unit delivering the proper amount of conditioned Air.

- Unit operation is acceptably quiet and free of vibration.
- Nothing is obstructing the supply air and return air to and from the unit.

#### **MAINTENANCE:**

Unit performance is maintained at optimum levels by implementing the following preventive measures:

#### **●FILTER MAINTENANCE**

COLD POINT 5QT units are furnished with a 1"X20"X25"throw away type air filter. The unit must not be operated without this filter installed. Filter should be inspected at least every three months, and replaced when dirty. Unit operation becomes very inefficient with dirty filters and system components are stressed. Unit warranty is void if filters are not maintained properly.

**Replace only with a filter with an equivalent pressure drop. Certain "High Efficiency" filters are not suitable and use of a non-approved type will Void the 5QT Warranty. If in doubt contact the factory for technical help in selecting the proper replacement filter.**

#### **●CONDENSATE DRAINS:**

Condensate drains can pick up lint and dirt, especially with dirty filters. Inspect, and if dirty, clean the condensate drain pan twice a year to avoid the possibility of overflow.

#### **●CHECK WIRING:**

Annually or as a part of a service maintenance check the tightness of the various wiring connections within the control panel.

#### **●FAN MOTORS:**

The direct-drive blower and fan motors have permanently sealed, lubricated bearings, and do not require periodic oiling. Adding a few drops of 20W non-detergent oil through the oil ports twice a year may however extend life of the bearings. **DO NOT** over oil.

#### **●MICROBIAL GROWTH:**

Microbial growth can occur in air conditioners within the air stream where moisture exists. ASHRAE standards 62-89 recommends that these surfaces be inspected and cleaned to limit contamination. This typically includes surfaces beginning at the finned coil, drain pan, insulation, and fan/blowers

#### **●INSPECTING AND CLEANING FINNED EVAPORATOR AND CONDENSER COILS:**

Coils become externally fouled as a result of normal

operation. Dirt on the surface of the coil reduces its ability to transfer heat that can result in comfort problems, increased resistance to airflow and result in increased operating energy costs. If the dirt on the surface of the coil becomes wet, such as commonly occurs with cooling coils, microbial growth can result which may cause unpleasant odors and serious health related indoor air quality problems. Coils should be inspected at least every six months or more often as necessary. The frequency of the required inspection/cleaning is dependent on the operating hours of the system, filter maintenance and efficiency, and dirt build-up. The following is the suggested method of cleaning coils:

- 1). Disconnect all electrical power to the unit.
- 2). Wear the appropriate personal protective equipment.
- 3). Gain access to the coil section of the unit (both sides).
- 4). Using a soft brush, remove loose debris from both sides of the coil.
- 5). Mix a high quality coil cleaning detergent with water according to the manufacturers instructions. If the detergent is strongly alkaline after mixing (8.5 pH or higher), it must contain a corrosion inhibitor. Carefully follow the cleaning solution manufacturers instructions regarding the use of the product.
- 6). Placed the mixed solution in a pump sprayer or high pressure sprayer. If a high pressure sprayer is used, note the following:
  - A. Maintain a minimum nozzle spray angle of 15 degrees.
  - B. Spray perpendicular to the coil face.
  - C. Protect other areas of the air handler and internal controls from contact with moisture or the cleaning solution.
  - D. Keep the nozzle at least 6 inches from the coil.
  - E. Do NOT exceed 600psi.
- 7). Spray the leaving air side of the coil first, then the entering air side. Use a block-off to prevent spray from going through the coil and into a dry section of the unit and/or system duct-work. Carefully follow the cleaning solution manufacturers usage instructions.
- 8). Thoroughly rinse both sides of the coil and the drain pan with cool, clean water.
- 9). Repeat steps 7 and 8 as necessary.
- 10). Using a fin brush straighten any coil fins that may have been damaged during the cleaning process.
- 11). Confirm that the drain line remains open following the cleaning process.
- 12). Replace all panels and parts.
- 13). Allow the unit to dry before putting unit back in service. Restore electrical power to the unit.
- 14). Be careful that the contaminated material does not come into contact with other areas of the unit or building. Properly dispose of all contaminated materials and used cleaning solution. Store unused solutions according to manufacturer's directions.



# 5QT SPARE PARTS LIST

## 208V

<b>Parts Description</b>	<b>Part No.</b>	<b>5QT-18</b>	<b>5QT-24</b>			
<b>High Pressure Switch</b>	<b>50060</b>	X	X			
<b>Crank Case Heater 48W, 240V</b>	<b>50025</b>	X	X			
<b>Compressor, 208/230V</b>	<b>10002</b>	X				
<b>Compressor, 208/230V</b>	<b>10021</b>		X			
<b>Evap Motor 208/230V</b>	<b>15008</b>	X	X			
<b>Condenser Motor 208/230V</b>	<b>15013</b>	X	X			
<b>Evap Coil</b>	<b>20036</b>	X	X			
<b>Condenser Coil</b>	<b>20118</b>	X	X			
<b>TXV Valve 1-1 1/2 ton Bi-Flow</b>	<b>40030</b>	X	X			
<b>Reversing Valve</b>	<b>40109</b>	X	X			
<b>Reversing Valve Solenoid</b>	<b>50181</b>	X	X			
<b>Evap Motor Capacitor 7.5/370</b>	<b>50027</b>	X	X			
<b>Comp./Cond. Motor Capacitor 30/5/370V</b>	<b>50116</b>	X	X			
<b>Electric Heater, 4.8 KW @ 230V (QTY. 2)</b>	<b>60103</b>	X	X			
<b>Electric Heater Limit Switch</b>	<b>60151</b>	X	X			
<b>Transformer 40VA, 24V</b>	<b>50003</b>	X	X			
<b>Compressor Contactor 30A, 1 1/2 Pole</b>	<b>50047</b>	X	X			
<b>Electric Heat Contactor 30A, 2 Pole</b>	<b>50048</b>	X	X			
<b>Control Board, Defrost</b>	<b>50081</b>	X	X			
<b>Relay, Evap Fan Motor</b>	<b>50131</b>	X	X			
<b>Defrost Thermostat</b>	<b>50172</b>	X	X			
<b>Louver (optional)</b>	<b>31297</b>	X	X			
<b>Air Filter 1" x 20" x 25"</b>	<b>70416</b>	X	X			



## All Product Limited Warranty

*Cold Point Corporation* warrants to the purchase/owner, that all products will be free from defects in material and workmanship under the normal use and maintenance.

### The warranty coverage period:

From the date of original installation: Twelve, (12) months for all components, and sixty, (60) months on unit compressors.

Or

From the date of original sale: Fifteen, (15) months for all components and Sixty-three, (63) months on unit compressor from the date of original sale. whichever comes first.

### What we will cover:

**PARTS:** *Cold Point Corp.* will replace any defective part with a new or rebuilt part at no charge. The replacement part then assumes the remaining portion of the warranty.

**LABOR:** Repair of defective units for the 12 month/ 15 month warranty coverage period. Labor will be reimbursed only in accordance with Cold Point Labor Allowance Policy Bulletin #PB001A. See Policy Bulletin for details.

### How:

**PARTS:** Replacement parts, except for compressors, will be provided at no charge upon receipt of an order. Failed compressor replacements must be authorized and returned to *Cold Point Corp.* Replacement compressors will be billed when shipped and credited upon receipt and inspection by *Cold Point Corp.* See Return Material Authorization Policy Bulletin #PB002 for details.

**LABOR:** *Cold Point Corp.* service department must be contacted for authorization of labor coverage prior to performing service work. Failure to do so will void the labor warranty.

### What we do not cover:

Labor or other costs incurred for removing, installing,

shipping, or handling of defective units.

Normal maintenance

Damage or repairs required as a consequence of faulty installation or application by others. Failure to start due to voltage conditions, blown fuses, open circuit breakers, or other damages due to the inadequacy or interruption of electrical service.

Damage or repairs needed as a consequence of any misapplication, abuse, improper servicing, unauthorized alteration, or improper operation.

Damage as a result of floods, wind, fires, lightning, accidents, corrosive atmosphere, or other conditions beyond the control of *Cold Point Corp.*

Products installed outside the United States or Canada.

Any damages to person or property of whatever kind, direct or indirect, special or consequential, whether resulting from use or loss of the product.

**Limit of Warranties:** This warranty is exclusive and in lieu of any implied warranties of merchantability and fitness for a particular purpose and all other warranties express or implied. The remedies provided for in this warranty are exclusive and shall constitute the only liabilities on the part of *Cold Point Corp.* including any statement made by any individual which shall be of no effect.

For Service, repair, or assistance:

- 1.) Contact the installer
- 2.) Call the nearest distributor
- 3.) Call, write, or e-mail:

*Cold Point Corp.*  
7500 Cold Point Dr.  
Rome, NY 13440  
Phone: 315.339.2331  
Fax: 315.339.2358  
Web: [www.coldpointcorp.com](http://www.coldpointcorp.com)



Before calling please gather and record the following information so that we are best able to help.

- \_\_\_ Unit Model No
- \_\_\_ Unit Serial number
- \_\_\_ Name of Job or Installation
- \_\_\_ Your Name
- \_\_\_ Your Company's Name
- \_\_\_ Your Company's Address
- \_\_\_ Your Company's Phone, Fax, and e-mail
- \_\_\_ Room Temperature -DB/WB
- \_\_\_ Outdoor Temperature- DB/ WB

- \_\_\_ Suction Pressure
- \_\_\_ Discharge pressure
- \_\_\_ Suction Superheat
- \_\_\_ Voltage @ contactor
- \_\_\_ Amp Reading (clamp-on)
- \_\_\_ Your Diagnosis or Question

Cold Point Corp.  
 7500 Cold Point Dr.  
 Rome, NY 13440  
 Phone:315.339.2331  
 Fax: 315.339.2358  
 e-mail: info@coldpointcorp.com

**RECORDS:**

Date of Installation \_\_\_\_\_

Model number \_\_\_\_\_

Serial number \_\_\_\_\_

Installing Contractor \_\_\_\_\_

Address \_\_\_\_\_

Phone No. \_\_\_\_\_

**SERVICE/MAINTENANCE:**

Date	Work Performed	BY
_____	_____	_____
_____	_____	_____
_____	_____	_____
_____	_____	_____
_____	_____	_____
_____	_____	_____

Notes: \_\_\_\_\_  
 \_\_\_\_\_  
 \_\_\_\_\_  
 \_\_\_\_\_  
 \_\_\_\_\_  
 \_\_\_\_\_  
 \_\_\_\_\_  
 \_\_\_\_\_  
 \_\_\_\_\_  
 \_\_\_\_\_  
 \_\_\_\_\_  
 \_\_\_\_\_