



**D E S I G N E D T O L E A D**

# BWC Series

Instructions for Field Conversion From:

- Natural Gas to LP
- LP to Natural Gas

## **DANGER**

These instructions include a procedure for adjusting the air-fuel mixture on this boiler. This procedure requires a combustion analyzer to measure the CO<sub>2</sub> (or Oxygen) and Carbon Monoxide (CO) levels in flue gas. Adjusting the air-fuel mixture without a proper combustion analyzer could result in unreliable boiler operation, personal injury, or death due to carbon monoxide poisoning.

## **WARNING**

This conversion kit shall be installed by a qualified service agency in accordance with the manufacturer's instructions and all applicable codes and requirements of the authority having jurisdiction. If the information in these instructions is not followed exactly, a fire, an explosion or production of carbon monoxide may result causing property damage, personal injury, or loss of life. The qualified service agency is responsible for proper installation of this kit. The installation is not proper and complete until the operation of the converted appliance is checked as specified in the manufacturer's instructions supplied with the kit.

## **IMPORTANT**

Not all BWC Series boilers may be used on both natural and LP gas. Before attempting a field conversion, refer to Table 1 to verify that the planned conversion is permitted.

In addition to these instructions, this kit consists of the following items:

Part Number	Description	Color
980236	Natural to LP Conversion Label Sheet ( 1 of 2)	Red
980246	Natural to LP Conversion Label Sheet ( 2 of 2)	Red
980237	LP to Natural Conversion Label Sheet ( 1 of 2)	Yellow
980247	LP to Natural Conversion Label Sheet ( 1 of 2)	Yellow

1) Make sure that the planned fuel conversion is listed in Table 1. If the planned conversion is not shown in Table 1, it is not permitted. Some of the models shown below may be equipped with either a Dungs or Honeywell gas valve. Refer to Figures 1 and 2 to identify the valve used on the model being converted.

**Table 1: Permitted Conversions**

Boiler Model	Gas Valve	Fuel Converted		Planned Installation Altitude
		From	To	
BWC070EN	Dungs GB-WND 055 (HO)	Natural Gas	LP	0-10200ft
BWC070EL	Dungs GB-WND 055 (HO)	LP	Natural Gas	0-10200ft
BWC090EN	Dungs GB-WND 055 (HO)	Natural Gas	LP	0-10200ft
BWC090EL	Dungs GB-WND 055 (HO)	LP	Natural Gas	0-10200ft
BWC120EN	Dungs GB-WND 055 (HO)	Natural Gas	LP	0-7800ft
BWC120EL	Dungs GB-WND 055 (HO)	LP	Natural Gas	0-10200ft
BWC150EN*	Dungs GB-WND 055 (RH)*	Natural Gas	LP	0-7800ft
BWC150EL	Dungs GB-WND 055 (RH)	LP	Natural Gas	0-10200ft
BWC151EN	Dungs GB-WND 055 (HO)	Natural Gas	LP	0-7800ft
BWC151EL	Dungs GB-WND 055 (HO)	LP	Natural Gas	0-10200ft
BWC225EN**	Honeywell VK8115	Natural Gas	LP	0-7800ft
BWC225EL	Honeywell VK8115	LP	Natural Gas	0-10200ft
BWC300EN	Dungs GB-WND 057	Natural Gas	LP	0-10200ft
BWC300EL	Dungs GB-WND 057	LP	Natural Gas	0-10200ft
BWC399EN	Dungs GB-WND 057	Natural Gas	LP	0-10200ft
BWC399EL	Dungs GB-WND 057	LP	Natural Gas	0-10200ft
BWC425EN	Dungs GB-WND 057	Natural Gas	LP	0-10200ft
BWC425EL	Dungs GB-WND 057	LP	Natural Gas	0-10200ft

\* Conversion of BWC150 EN boilers equipped with Honeywell gas valves to LP is not permitted.

\*\* Do not attempt to convert BWC225EN to LP at altitudes above 2000 ft unless the manufacturing date on the rating plate is after 6/1/10.

2) Conversion of BWC series boilers from one fuel to another is accomplished using the throttle screw on the gas valve. Figure 1 shows the location of the throttle screw on the Dungs GB-WND 055 valve. Figure 2 shows the location of the throttle screw on the Honeywell valve. Figure 3 shows the location of the throttle screw on the Dungs GB-WND 057 valve. Locate the throttle on the boiler being converted.

3) If conversion is being made on a new installation, install the boiler in accordance with the installation instructions supplied with the boiler. If an installed boiler is being converted, connect the new gas supply to the boiler, check for gas leaks, and purge the gas line up to the boiler in accordance with the National Fuel Gas Code (ANS Z223.1) or the requirements of the authority having jurisdiction.

4) Before attempting to start the boiler, make the number of turns to the throttle screw called for in the Table 2 below.

- When converting from Natural to LP gas, the screw is turned clockwise.
- When converting from LP to Natural Gas, the screw is turned counter-clockwise.

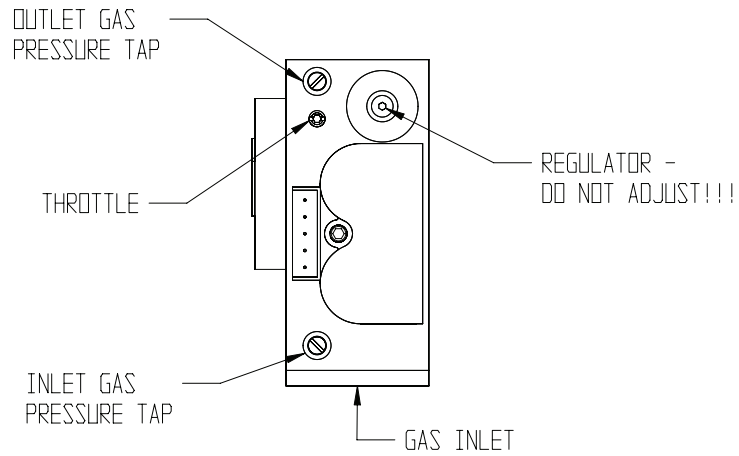

Figure 1a: Dungs "HO" Gas Valve Detail (BWC070, BWC090, BWC120, BWC151)

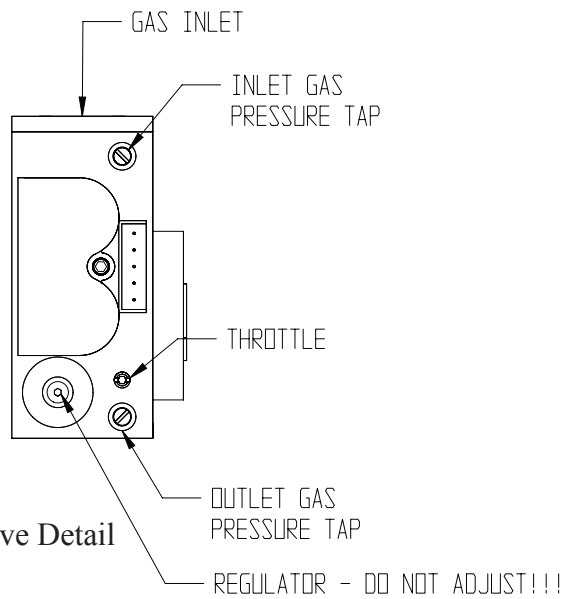

Figure 1b: Dungs "RH" Gas Valve Detail (BWC150)

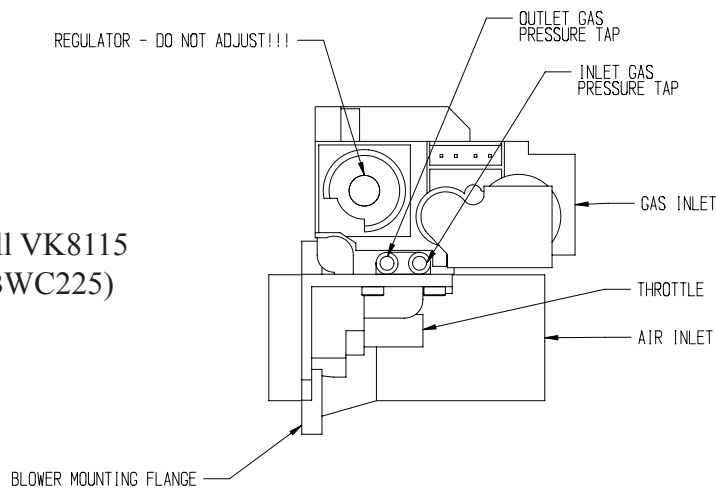
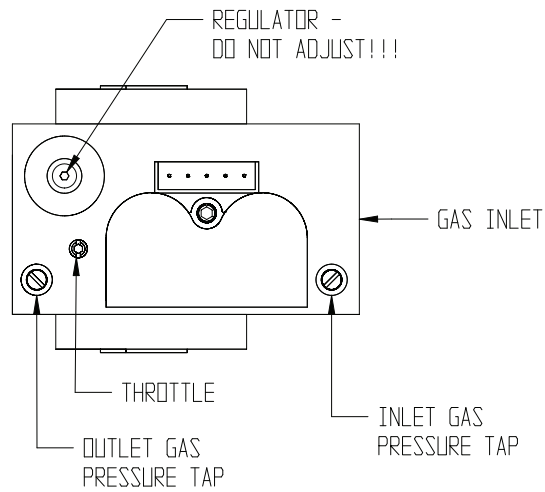

Figure 2: Honeywell VK8115 Gas Valve Detail (BWC225)

Figure 3: Dungs GB-WND 057 Gas Valve Detail (BWC300, BWC399, BWC425)



### WARNING

The pressure regulator has been factory set using precision instruments and must never be adjusted in the field. The gas valve outlet pressure is the same for both natural gas and propane. Make sure that all adjustments are made with the throttle, not the pressure regulator. Attempting to adjust the pressure regulator will result in damage to the gas valve and may cause property damage, personal injury or loss of life.

### WARNING

The throttle adjustments shown in Table 2 are approximate. The final throttle setting must be found using a combustion analyzer. Leaving the boiler in operation with a CO level in excess of the value shown in Table 3 could result in injury or death from carbon monoxide poisoning.

Table 2: Number of Throttle Turns

Boiler Model	Gas Valve	Full Turns at Various Altitudes			
		0-2000ft	2000-5200ft	5200-7800ft	7800ft-10200ft
BWC070	Dungs GB-WND 055 (HO)	2 3/4	2 3/4	2 3/4	2 3/4
BWC090	Dungs GB-WND 055 (HO)	2 3/4	2 3/4	2 3/4	2 3/4
BWC120	Dungs GB-WND 055 (HO)	4	4 1/2	4 1/2	
BWC150	Dungs GB-WND 055 (RH)	4 1/4	5	5	
BWC151	Dungs GB-WND 055 (HO)	4	4	4	
BWC225	Honeywell VK8115	3 1/2	3 1/2	3 1/2	3 1/2
BWC300	Dungs GB-WND 057	2 1/2	2 1/2	2 1/2	2 1/2
BWC399	Dungs GB-WND 057	2 1/2	2 1/2	2 1/2	2 1/2
BWC425	Dungs GB-WND 057	2 1/2	2 1/2	2 1/2	2 1/2

## IMPORTANT

**If the throttle is very far out of adjustment on the “rich” (counter-clockwise) side, the rules for adjusting the CO<sub>2</sub> will reverse: CO<sub>2</sub> will actually drop as the throttle is turned counterclockwise and increase as the throttle is turned clockwise. Under these conditions, the O<sub>2</sub> level will read 0% and the CO level will be extremely high (well over 1000PPM). If the boiler appears to be operating under these conditions, turn the throttle clockwise. If this is the problem, the CO<sub>2</sub> level will rise as the throttle is turned clockwise, eventually peaking at between 11% and 13% before falling. Once the CO<sub>2</sub> peaks, the CO level should start to fall. After this happens, continue turning the throttle clockwise until the CO<sub>2</sub> drops (or O<sub>2</sub> increases) to the level shown in Table 3.**

5) Attempt to start the boiler using the lighting instructions located inside the lower front cover of the boiler. If the boiler does not light on the first try for ignition, allow to boiler to make at least four more attempts to light. If boiler still does not light, turn the throttle counter clockwise in 1/4 turn increments, allowing the boiler to make at least three tries for ignition at each setting, until the boiler lights.

6) After the burner lights, force the burner to high fire by simultaneously pressing and holding the “Mode” button and “+“ button. After a few seconds, the display should flash “H”, indicating that the boiler has been driven to high fire. Allow the boiler to operate for approximately 5 minutes before taking combustion readings. Note: after 15 minutes, the boiler is automatically released from high fire hold. Be sure to restore high fire hold if additional time is needed to obtain high fire combustion readings.

7) Perform a combustion test. Boilers equipped with a concentric vent system have a flue gas sample tap located in the boiler vent collar (under the screw cap). For other vent systems, the sample probe may be inserted into the terminal. If this is not possible, remove the flue temperature sensor and insert the analyzer probe in the sensor opening. For the boiler to operate, this sensor will need to be remain connected to the wiring. If the flue gas sensor is removed, be sure to replace it after combustion testing is complete.

8) While the burner is at high fire adjust the throttle as needed to obtain the CO<sub>2</sub> (or O<sub>2</sub>) settings shown in the Table 3:

- To reduce the CO<sub>2</sub> (increase the O<sub>2</sub>) turn the throttle clockwise
- To increase the CO<sub>2</sub> (reduce the O<sub>2</sub>) turn the throttle counter-clockwise

Make adjustments in increments of 1/8 to 1/4 turn and allow the boiler at least a minute to respond to each adjustment before making another. In general, the CO level will be at its lowest somewhere in the CO<sub>2</sub> range shown in this table.

**Table 3a: Recommended Combustion Settings, Natural Gas**

Boiler Model	Altitude								
	0-2000ft			5200-7800ft			7800ft-10200ft		
	CO <sub>2</sub>	O <sub>2</sub>	Max CO	CO <sub>2</sub>	O <sub>2</sub>	Max CO	CO <sub>2</sub>	O <sub>2</sub>	Max CO
	(%)	(%)	PPM	(%)	(%)	PPM	(%)	(%)	PPM
BWC070	9.4	4.4	75	9.4	4.4	75	9.0	5.1	75
BWC090	9.5	4.3	75	9.5	4.3	75	9.1	4.9	100
BWC120	9.5	4.3	75	9.5	4.3	75	8.8	5.4	100
BWC150	8.7	5.6	75	8.7	5.6	75	8.7	5.6	100
BWC151	9.5	4.3	75	9.5	4.3	75	9.0	5.1	100
BWC225	9.0	5.1	75	9.0	5.1	100	8.8	5.4	100
BWC300	9.0	5.1	75	9.0	5.1	75	8.8	5.4	100
BWC399	9.0	5.1	75	9.0	5.1	75	8.8	5.4	100
BWC425	9.0	5.1	75	9.0	5.1	75	8.8	5.4	100

**Table 3b: Recommended Combustion Settings, LP Gas**

Boiler Model	Altitude								
	0-2000ft			5200-7800ft			7800ft-10200ft		
	CO <sub>2</sub>	O <sub>2</sub>	Max CO	CO <sub>2</sub>	O <sub>2</sub>	Max CO	CO <sub>2</sub>	O <sub>2</sub>	Max CO
	(%)	(%)	PPM	(%)	(%)	PPM	(%)	(%)	PPM
BWC070	10.4	5.1	75	10.4	5.1	75	10.2	5.4	100
BWC090	10.5	5.0	75	10.5	5.0	100	10.3	5.3	100
BWC120	10.5	5.0	75	10.5	5.0	100			
BWC150	10.1	5.6	75	10.1	5.6	100			
BWC151	10.5	5.0	75	10.5	5.0	100			
BWC225	10.2	5.4	75	10.2	5.4	100			
BWC300	10.2	5.4	75	9.9	5.8	100			
BWC399	10.2	5.4	75	9.9	5.8	100	9.9	5.8	100
BWC425	10.2	5.4	75	9.9	5.8	100	9.9	5.8	100

Note: The CO<sub>2</sub> and O<sub>2</sub> values shown in Table 3 are at high fire and are +/-0.1%.

9) Verify that the gas inlet pressure is between the upper and lower limits shown in Table 4 with all gas appliances (including the converted boiler) both on and off:

**Table 4: Inlet Pressure Limits**

Fuel	Inlet Pressure (inches w.c.)	
	Min.	Max.
Natural Gas	5.0	14.0
LP	11.0	13.0

10) Two sheets of labels are provided with this kit: one for conversions from natural to LP gas and one for conversions from LP to natural gas. Select the appropriate sheet of labels and apply them as follows:

- Apply the “Rating Plate Label” adjacent to the rating plate.
- Apply the “Gas Valve Label” to a conspicuous area on the gas valve.
- Apply the “Boiler Conversion Label” to a conspicuous surface on, or adjacent to, the outer boiler jacket. Fill in the date of the conversion and the name and address of the company making the conversion with a permanent marker.

11) Refer to the “Start-up and Checkout” section of the boiler installation manual and perform any checks not already completed.



---

Manufacturer of Hydronic Heating Products  
P.O. Box 14818 3633 I. Street  
Philadelphia, PA 19134  
[www.crownboiler.com](http://www.crownboiler.com)

PN: 980235  
BWC - 01/12 Rev2