

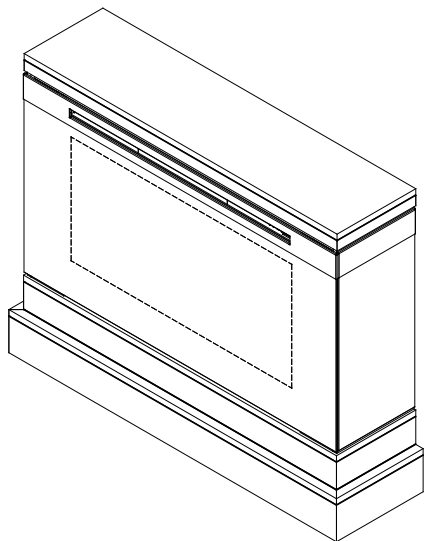

Better solutions through innovation



## Owner's Manual

Model  
DCF44

---







**IMPORTANT SAFETY INFORMATION:** Always read this manual first before attempting to install or use this fireplace. For your safety, always comply with all warnings and safety instructions contained in this manual to prevent personal injury or property damage.

To view the full line of Dimplex products, please visit [www.dimplex.com](http://www.dimplex.com)

7210050100R05



## Table of Contents

 Welcome & Congratulations . . . . .	3
 IMPORTANT INSTRUCTIONS . . . . .	4
 Installation . . . . .	7
 Operation . . . . .	8
 Maintenance . . . . .	13
 Warranty . . . . .	14
 Replacement Parts . . . . .	16

Always use a qualified technician or service agency to repair this fireplace.

**! NOTE:** Procedures and techniques that are considered important enough to emphasize.

**⚠ CAUTION:** Procedures and techniques which, if not carefully followed, will result in damage to the equipment.

**⚠ WARNING:** Procedures and techniques which, if not carefully followed, will expose the user to the risk of fire, serious injury, or death.

## **Welcome & Congratulations**

Thank you and congratulations for choosing to purchase an electric fireplace from Dimplex, the world leader in electric fireplaces.

**Please carefully read and save these instructions.**

**⚠ CAUTION:** Read all instructions and warnings carefully before starting installation. Failure to follow these instructions may result in a possible electric shock, fire hazard and will void the warranty.

Please record your model and serial numbers below for future reference: model and serial numbers can be found on the Model and Serial Number Label of your fireplace.

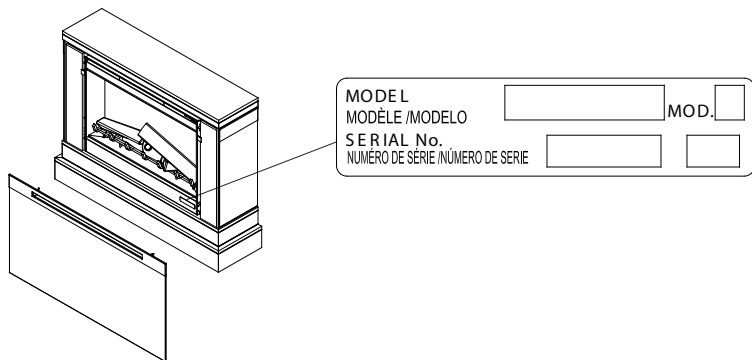

**NO NEED TO RETURN TO THE STORE**

Questions with operation or assembly? Require Parts Information?  
Product Under Manufacturer's Warranty?

**Contact us at:**  **[www.dimplex.com/customer\\_support](http://www.dimplex.com/customer_support)**  
For Troubleshooting and Technical Support

**OR**  **Toll-Free 1-888-DIMPLEX (1-888-346-7539)**  
Monday to Friday 8:00 a.m. to 4:30 p.m. EST  
Please have your model number and product serial number ready. (See above)

# IMPORTANT INSTRUCTIONS

When using electrical appliances, basic precautions should always be followed to reduce the risk of fire, electric shock, and injury to persons, including the following:

- ① Read all instructions before using the electric fireplace.
- ② The heater is hot when in use. To avoid burns, do not let bare skin touch hot surfaces. The trim around the heater outlet becomes hot during heater operation.
- ③ Extreme caution is necessary when any heater is used by or near children or invalids and whenever the unit is left operating and unattended.
- ④ Always unplug the electric fireplace when not in use.
- ⑤ Do not operate any heater after it malfunctions. Disconnect power at the service panel and have the heater inspected by a reputable electrician before reusing.
- ⑥ Do not operate any unit with a damaged cord or plug, or if the heater has malfunctioned, or if the electric fireplace has been dropped or damaged in any manner, contact Dimplex Technical Service at 1-888-346-7539.
- ⑦ Do not use outdoors.
- ⑧ The electric fireplace is not intended for use in bathrooms, laundry areas and similar indoor locations. Never locate heater where it may fall into a bathtub or other water container.
- ⑨ Do not run the cord under carpeting. Do not cover cord with throw rugs, runners, or the like. Arrange cord away from traffic area and where it will not be tripped over.
- ⑩ To disconnect the unit, turn the controls off, then remove the plug from the outlet.
- ⑪ Do not insert or allow foreign objects to enter any ventilation or exhaust opening as this may cause an electric shock or fire, or damage to the heater.
- ⑫ To prevent a possible fire, do not block air intake or exhaust in any manner. Do not use on soft surfaces, like a bed, where openings may become blocked.
- ⑬ All electrical heaters have hot and arcing or sparking parts inside. Do not use in areas where gasoline, paint, or flammable liquids are used or stored.
- ⑭ Do not modify the electric fireplace. Use it only as described in this manual. Any other use not recommended by the manufacturer.

# IMPORTANT INSTRUCTIONS

er may cause fire, electric shock or injury to persons.

- ⑮ Always plug heaters directly into a wall outlet/receptacle. Never use with an extension cord or relocatable power tap (outlet/power strip).
- ⑯ Do not burn wood or other materials in the electric fireplace.
- ⑰ Do not strike the fireplace glass.
- ⑱ Always use a certified electrician should new circuits or outlets be required.
- ⑲ Always use properly grounded, fused and polarized outlets.
- ⑳ Disconnect all power supply before performing any cleaning, maintenance or relocation of the unit.
- ㉑ When transporting or storing the unit and cord, keep in a dry place, free from excessive vibration and store so as to avoid damage.

 **WARNING:** Remote control contains small batteries. Keep away from children. If swallowed, seek medical attention immediately.

 **WARNING:** Do not install battery backwards, charge, put in fire or mix with used or other battery types - may explode or leak causing injury.

**! NOTE:** Changes or modifications not expressly approved by the party responsible for compliance could void user's authority to operate the equipment.



**CAUTION**  
RISK OF ELECTRIC SHOCK  
DO NOT OPEN  
NO USER-SERVICEABLE PARTS INSIDE



## SAVE THESE INSTRUCTIONS

# IMPORTANT INSTRUCTIONS

 **CAUTION:** This equipment has been tested and found to comply with the limits for a Class B digital device, pursuant to Part 15 of the FCC Rules. These limits are designed to provide reasonable protection against harmful interference in a residential installation. This equipment generates uses and can radiate radio frequency energy and, if not installed and used in accordance with the instructions, may cause harmful interference to radio communications. However, there is no guarantee that interference will not occur in a particular installation. If this equipment does cause harmful interference to radio or television reception, which can be determined by turning the equipment off and on, the user is encouraged to try to correct the interference by one of the following measures:

- Reorient or relocate the receiving antenna.
- Increase the separation between the equipment and receiver.
- Connect the equipment into an outlet on a circuit different from that to which the receiver is connected.
- Consult the dealer or an experienced radio/TV technician for help.

This device complies with Part 15 of the FCC Rules. Operation is subject to the following two conditions: (1) This device may not cause harmful interference, and (2) this device must accept any interference received, including interference that may cause undesired operation.

 **FCC CAUTION:** Any changes or modifications not expressly approved by the party responsible for compliance could void the user's authority to operate this equipment.

This device complies with Industry Canada licence-exempt RSS standard(s). Operation is subject to the following two conditions: (1) this device may not cause interference, and (2) this device must accept any interference, including interference that may cause undesired operation of the device.

Under Industry Canada regulations, this radio transmitter may only operate using an antenna of a type and maximum (or lesser) gain approved for the transmitter by Industry Canada. To reduce potential radio interference to other users, the antenna type and its gain should be so chosen that the equivalent isotropically radiated power (e.i.r.p.) is not more than that necessary for successful communication.

## Installation

**⚠ WARNING:** Ensure the power cord is not installed so that it is pinched or against a sharp edge and ensure that the power cord is stored or secured to avoid tripping or snagging to reduce the risk of fire, electric shock or injury to persons.

**⚠ WARNING:** Construction and electrical outlet wiring must comply with local building codes and other applicable regulations to reduce the risk of fire, electric shock and injury to persons.

**⚠ WARNING:** Do not attempt to wire your own new outlets or circuits. To reduce the risk of fire, electric shock or injury to persons, always use a licensed electrician.

**⚠ WARNING:** To reduce the risk of fire, do not store or use gasoline or other flammable vapors or liquids in the vicinity of the heater.

1. Select a suitable location that is not susceptible to moisture and is away from drapes, furniture and high traffic.

**⚠ CAUTION:** High temperature, risk of fire, keep electrical cords, drapery, furnishings, and other combustibles at least 3 feet (0.9 m) from the front of the heater.

2. For ease of electrical hook up you may wish to locate the fireplace near an existing

outlet.

**! NOTE:** A 15 Amp, 120 Volt circuit is required. A dedicated circuit is preferred but not essential in all cases. A dedicated circuit will be required if, after installation, the circuit breaker trips or fuse blows on a regular basis when the heater is operating. Additional appliances on the same circuit may exceed the current rating of the circuit breaker.

3. Store the fireplace in a safe dry and dust free location.

**! NOTE:** The dimensions of the fireplace are 44 in. (1118 mm) wide x 34 in. (883 mm) high x 11 5/8 in. (295 mm) deep. The fireplace does not require any additional venting.

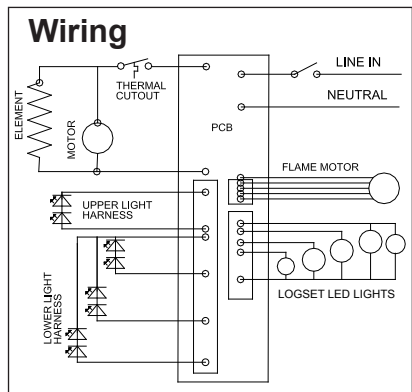

## 🔑 Operation

Figure 1

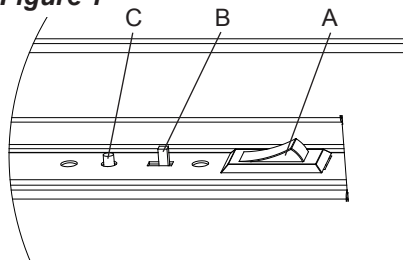

**⚠️ WARNING:** This electric firebox must be properly installed before it is used.

### Manual Controls

The manual controls for the fireplace are located in the upper right hand corner (Figure 1).

#### A. On/Off Switch

Supplies power to the 3-position manual control switch.

#### B. 3-Position Switch

**Remote (left position):** The unit is operated with the remote control.

**Flame (center position):** The flame effect is turned ON.

**Flame & Heat (right position):** The flame effect and heater are turned ON simultaneously. When the manual control is in the **Flame & Heat** position the heater does not run on the remote

operated thermostat.

**! NOTE:** When the 3-position switch is in the **Flame** and **Flame & Heat** positions, the fireplace unit will not operate with the remote control.

#### C. Initialization Button

Used to synchronize the remote control.

**! NOTE:** The heater on your fireplace may emit a slight, harmless odor when first used. This odor is a normal condition caused by the initial heating of internal heater parts and will not occur again.

### Resetting The Temperature Cutoff Switch

Should the heater overheat, an automatic switch will turn the heater off and it will not come back on without being reset. The temperature cutoff switch can be reset by unplugging the unit, waiting five minutes and plugging the unit back in.

**⚠️ CAUTION:** If you need to continuously reset the heater, unplug the unit and call Dimplex North America Limited at 1-888-346-7539. Please have your



## Operation

model and serial number ready when calling.

### Remote Control

The remote control has a range of approximately 50 feet (15.25 m), it does not have to be pointed at the fireplace and can pass through most obstacles (including walls). It is supplied with 243 independent frequencies to prevent interference with other units.

### Battery Installation

1. Depress tab on the battery cover on the back of the remote control and remove battery cover (Figure 2).
2. Install two AAA batteries into the remote control (included).
3. Ensure child lock is in the “unlocked” position.
4. Replace the battery cover.

**! NOTE:** When the “BAT”

**Figure 2**

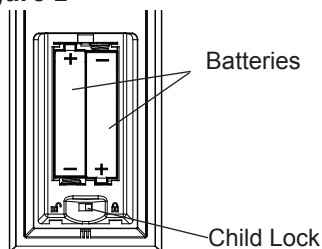

symbol is present on the remote control it is recommended to replace the batteries promptly, to maintain full functionality of the remote/fireplace. The remote control has a battery backup time of only several hours.



Battery must be recycled or disposed of properly. Check with your Local Authority or Retailer for recycling advice in your area.

### Remote Control Initializing/Reprogramming

1. Plug cord into 120 Volt wall outlet.
2. Ensure the On/Off switch located in the switch box on the fireplace in the upper right hand corner is in the **■** ON position.
3. Set the 3 position manual control to the **Remote** position (left position).
4. Press and hold the initialization button on the unit.
5. While holding the initialization button, press the Flame/Heat ON/OFF  button on the remote control.
6. Release the initialization

## Operation

button on the unit.

7. Press the Flame/Heat On/Off button  to turn the Flame/Heat function ON.

### Frequency Interference

If the fireplace does not respond properly to the remote control, the remote operating frequency may have to be reset. The remote control can send another frequency code to the circuit board to eliminate interference.

1. Simultaneously press the **“Temperature Down”** button and the **“Flame Speed Down”** button on the remote control.
2. **“COD”** will appear in place of the sleep timer digits.
3. Release the **“Temperature Down”** button and the **“Flame Speed Down”** button.
4. Press the initialization button on the unit.
5. Press the  button on the remote.

Your remote will now have a different frequency communicating with the fireplace.

### Remote Control Functions

(All letter references are to Figure 6)

#### B. Set Temperature

Press **F** button  to turn fireplace on.

Press **H** to raise thermostat.

Press **G** to lower thermostat.

Press both **H** and **G** to change °F to °C.

#### C. Dimmer

Press the **F** button  to turn the Flame/Heat on.

Repeatedly press the **J** or **I** button to decrease or increase the brightness of the upper lights.

#### D. Flame Speed

Press the **F** button  to turn the Flame/Heat on.

Press the **L** button to increase the speed of the flame.

Press the **K** to decrease the speed of the flame.

#### E. Sleep Timer

The Sleep Timer automatically shuts off the fireplace after a preset time (from 30 minutes to 8 hours).

Press the **F** button  to turn the fireplace on.

## 🔑 Operation

### Figure 3 - Remote Control Functions

- A. Room Temperature
- B. Set Temperature
- C. Dimmer
- D. Flame Speed Control
- E. Sleep Timer
- F. Flame & Heat On/Off
- G. Temperature Down
- H. Temperature Up
- I. Dimmer Down
- J. Dimmer Up
- K. Flame Speed Down
- L. Flame Speed Up
- M. Sleep Timer Down
- N. Sleep Timer Up

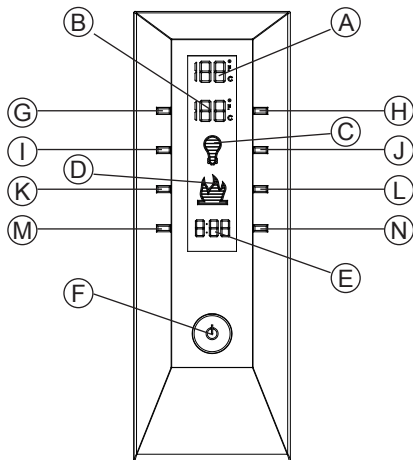

To set the sleep timer press the **N** button.

Set the timer from 30 minutes through 8 hours. The fireplace will automatically turn off when the sleep timer reaches zero (0) minutes.

The Sleep Timer can be cancelled at any time by pressing the **M** button repeatedly until the sleep timer displays nothing.

#### F. Flame & Heat On/Off Button

Press the **F** button  to turn the Flame/Heat function on.

When **B** is higher than **A** the heat will come on. To turn the heat off, lower the **B** so that it's setting is lower than the **A**. The default temperature setting is 72°F (22°C).

**! NOTE:** When using the remote control the heater runs on a thermostat. Press the **H** or **G** buttons to adjust the set temperature. Once the desired set temperature is reached the heater will turn off. The heater will cycle on and off to maintain the desired set temperature.

## Operation

### Disable Heat

If desired, depending on the season, the heater on the unit can be disabled. The unit will operate in the same fashion, with remainder of the controls.

**To Disable** - Press **M** and **H** at the same time. The temperature setting on the remote will no longer be visible.

**! NOTE:** The heat will not work in manual controls either.

**To Enable** - Press **I** and **K** at the same time. The temperature setting will now be visible again.

### Child Lock (Figure 4)

1. Depress tab on the battery cover on the back of the remote control and remove the battery cover (Figure 3).
2. Move **Child Lock** tab to the right to lock the remote control.
3. Move **Child Lock** tab back to the left to unlock the remote control.
4. Replace the battery cover.

**! NOTE:** To temporarily unlock the remote control press (in order) **G** then **H** then **I**.

When the remote control's backlight is illuminated the **Child Lock** is bypassed. When the backlight is off the **Child Lock** is re-activated.

**Figure 4**

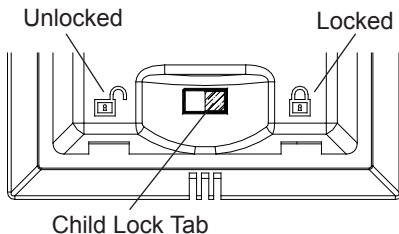



## Maintenance

**⚠ WARNING:** Disconnect power before attempting any maintenance or cleaning to reduce the risk of fire, electric shock or damage to persons.

**! NOTE:** The fireplace should not be operated with an accumulation of dust or dirt on or in the unit, as this can cause a build up of heat and eventual damage. For this reason the heater must be inspected regularly, depending upon conditions and at least at yearly intervals.

### Glass Cleaning

The glass is cleaned in the factory during the assembly operation. During shipment, installation, handling, etc., the glass may collect dust particles; these can be removed by dusting lightly with a clean dry cloth.

To remove fingerprints or other marks, the glass can be cleaned with a damp cloth. To prevent scratching, do not use abrasive cleaners or spray liquids on the glass surface.

### Fireplace Surface Cleaning

Use a cloth dampened with warm water only to clean painted surfaces of the electric fireplace. Do not use abrasive cleaners.

### Servicing

Except for installation and cleaning described in this manual, an authorized service representative should perform any other servicing.



## Warranty

### *Products to which this limited warranty applies*

This limited warranty applies to your newly purchased Dimplex electric compact fireplace. This limited warranty applies only to purchases made in any province of Canada *except* for Yukon Territory, Nunavut, or Northwest Territories or in any of the 50 States of the USA (and the District of Columbia) *except* for Hawaii and Alaska. This limited warranty applies to the original purchaser of the product only and is not transferable.

### *Products excluded from this limited warranty*

Products purchased in Yukon Territory, Nunavut, Northwest Territories, Hawaii, or Alaska are not covered by this limited warranty. Products purchased in these States, provinces, or territories are sold AS IS without warranty or condition of any kind (including, without limitation, any implied warranties or conditions of merchantability or fitness for a particular purpose) and the entire risk of as to the quality and performance of the products is with the purchaser, and in the event of a defect the purchaser assumes the entire cost of all necessary servicing or repair.

### *What this limited warranty covers and for how long*

Products covered by this limited warranty have been tested and inspected prior to shipment and, subject to the provisions of this warranty, Dimplex warrants such products to be free from defects in material and workmanship for a period of 12 months from the date of the first purchase of such product.

The limited 12 month warranty period also applies to any implied warranties that may

exist under applicable law. Some jurisdictions do not allow limitations on how long an implied warranty lasts, so the above limitation may not apply to the purchaser.

### *What this limited warranty does not cover*

This limited warranty does not apply to products that have been repaired (except by Dimplex or its authorized service representatives) or otherwise altered. This limited warranty does further not apply to defects resulting from misuse, abuse, accident, neglect, incorrect installation, improper maintenance or handling, or operation with an incorrect power source.

### *What you must do to get service under this limited warranty*

Defects must be brought to the attention of Dimplex Technical Service by contacting Dimplex at 1-888-346-7539, or 1367 Industrial Road, Cambridge Ontario, Canada N1R 7G8. Please have proof of purchase, catalogue/model and serial numbers available when calling. Limited warranty service requires a proof of purchase of the product.

### *What Dimplex will do in the event of a defect*

In the event a product or part covered by this limited warranty is proven to be defective in material or workmanship during the 12 month limited warranty period you have the following rights:

- Dimplex will in its sole discretion either repair or replace such defective product or part without charge. If Dimplex is unable to repair or replace such product or part, or if repair or replacement is not commercially practicable or cannot be timely made, Dimplex may, in lieu of repair or replacement,



## Warranty

choose to refund the purchase price for such product or part.

- Limited warranty service will be performed solely by dealers or service agents of Dimplex authorized to provide limited warranty services.
- The purchaser is responsible for removal and transportation of such product or part (and any repaired or replacement product or part) to and from the authorized dealer's or service agent's place of business.
- This limited warranty does not entitle the purchaser to on-site or in-home services. On-site or in-home services may be performed at the purchaser's specific request and expense at Dimplex's then-current rates for such services.
- Dimplex will not be responsible for, and the limited warranty services shall not include, any expense incurred for installation or removal of the product or part (or any replacement product or part) or any labour or transportation costs. Such costs shall be the purchaser's responsibility.

*What Dimplex and its dealers and service agents are also not responsible for:*

IN NO EVENT WILL DIMPLEX, OR ITS DIRECTORS, OFFICERS, OR AGENTS, BE LIABLE TO THE PURCHASER OR ANY THIRD PARTY, WHETHER IN CONTRACT, IN TORT, OR ON ANY OTHER BASIS, FOR ANY INDIRECT, SPECIAL, PUNITIVE, EXEMPLARY, CONSEQUENTIAL, OR INCIDENTAL LOSS, COST, OR DAMAGE ARISING OUT OF OR IN CONNECTION WITH THE SALE, MAINTENANCE, USE, OR INABILITY TO USE THE PRODUCT, EVEN IF DIM-

PLEX OR ITS DIRECTORS, OFFICERS, OR AGENTS HAVE BEEN ADVISED OF THE POSSIBILITY OF SUCH LOSSES, COSTS OR DAMAGES, OR IF SUCH LOSSES, COSTS, OR DAMAGES ARE FORESEEABLE. IN NO EVENT WILL DIMPLEX, OR ITS OFFICERS, DIRECTORS, OR AGENTS BE LIABLE FOR ANY DIRECT LOSSES, COSTS, OR DAMAGES THAT EXCEED THE PURCHASE PRICE OF THE PRODUCT. SOME JURISDICTIONS DO NOT ALLOW THE EXCLUSION OR LIMITATION OF INCIDENTAL OR CONSEQUENTIAL DAMAGES, SO THE ABOVE LIMITATION OR EXCLUSION MAY NOT APPLY TO THE PURCHASER.

### *How State and Provincial law apply*

This limited warranty gives you specific legal rights, and you may also have other rights which vary from jurisdiction to jurisdiction. The provisions of the United Nations Convention on Contracts for the Sale of Goods shall not apply to this limited warranty or the sale of products covered by this limited warranty.



## Replacement Parts

Flicker Motor . . . . .	3000240200KIT
Flicker Rod . . . . .	5901250100RP
Heater Assembly (with cutout). . . . .	2000330200RP
On/Off Switch . . . . .	2800070200RP
Remote Control Switchboard. . . . .	3000300300RP
Remote Control . . . . .	3001070100RP
Remote Control Receiver . . . . .	3001200100RP
Power Cord . . . . .	4100040300RP
Log Set . . . . .	0439070100RP
Partially Reflective Glass. . . . .	5900910100RP
Lower Light Assembly . . . . .	3001210100RP
Upper Light Assembly . . . . .	2500730100RP



**Dimplex North America Limited**  
 1367 Industrial Road  
 Cambridge ON  
 Canada N1R 7G8

© 2013 Dimplex North America Limited