

# Marshall Electronics

**V-LCD70P-HDMI**

7" High Resolution Field Monitor

---

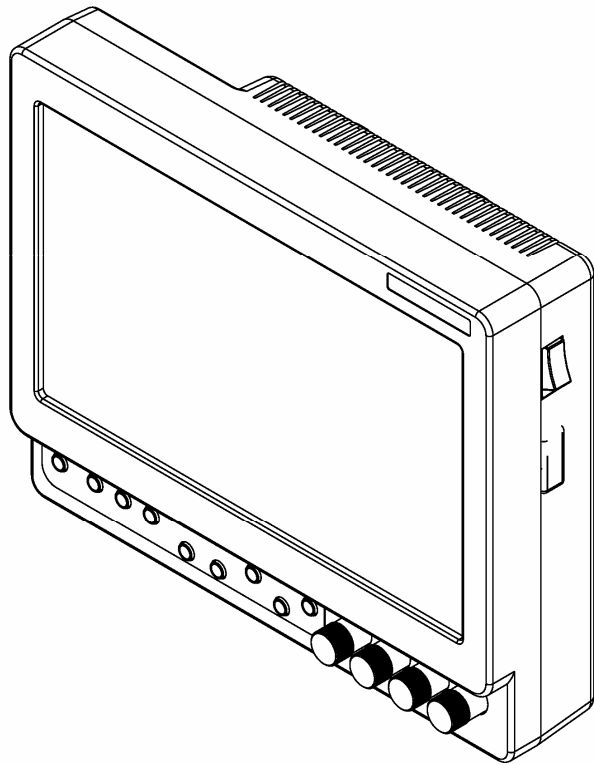

## Operating Instructions

This page intentionally left blank.

# Contents

<b>Product Overview</b> .....	4
<b>Features</b> .....	4
<b>Installation and Initial Setup</b> .....	5
Unpacking.....	5
Mounting.....	5
Changing the Battery Adapter.....	5
Connections and Power-On.....	5
<b>Front and Side Panel Features</b> .....	6
Power Button.....	6
Menu Navigation Buttons .....	6
User-Definable Function Buttons.....	6
Menu Navigation Buttons .....	6
Image Adjustment Knobs .....	6
Power Switch.....	6
Service Connecetor .....	6
<b>Rear Panel Features</b> .....	7
Component and Composite Input and Output.....	7
HDMI Input Connector .....	7
Power Input .....	7
Battery Adapter .....	7
1/4-20 Mounting Hole.....	7
<b>Compatible Input Formats</b> .....	8
<b>On-Screen Menu</b> .....	9
<b>STRUCTURE OVERVIEW</b> .....	9
<b>MAIN MENU AND NAVIGATION</b> .....	9
<b>VIDEO CONFIGURATION SUBMENU</b> .....	10
<i>Color Temperature Presets</i> .....	10
<i>RGB Bias and Gain</i> .....	10
<i>Check Field</i> .....	11
<i>Aspect Ratio Setting</i> .....	11
<i>Pixel-to-Pixel Mode</i> .....	12
<i>H/V Delay</i> .....	12
<i>Underscan</i> .....	12
<i>NTSC Black Level</i> .....	12
<b>MARKER CONFIGURATION SUBMENU</b> .....	13
<i>Markers</i> .....	13
<i>Center Marker</i> .....	13
<i>16:9 Markers / Full Screen Markers</i> .....	13
<i>4:3 Markers</i> .....	14
<i>Marker Background</i> .....	14
<b>FILTER CONFIGURATION SUBMENU</b> .....	15
<i>False Colors</i> .....	15
<b>FILTER CONFIGURATION SUBMENU</b> .....	16
<i>Peaking Filter (Focus Assist)</i> .....	16
<i>Mosquito Filter</i> .....	16
<b>SYSTEM CONFIGURATION SUBMENU</b> .....	17
<i>Input Format OSD</i> .....	17
<i>User-Definable Function Buttons</i> .....	17
<i>Freeze Input</i> .....	17
<i>Manufacturer Default</i> .....	17
<i>HDMI Input Format</i> .....	17
<b>Specifications</b> .....	18
<b>Maintenance</b> .....	19
<b>Warranty</b> .....	19

# Product Overview

---

The V-LCD70P-HDMI is a 7.0" high-definition widescreen LCD monitor featuring our completely digital TFT-MegaPixel active matrix LCD platform. With built-in focus assist and false color filters, this monitor is ideal as a light-weight high resolution viewfinder or focus-assist monitor. Our proprietary digital signal processing features 10-bit A/D conversion of all analog signals, with 4X over-sampling and 5-line super-adaptive 2D comb filtering of composite signals. De-interlacing is performed using our HyperProcess algorithm with motion adaptive interpolation. Multi-format compatibility accommodates virtually all video formats including NTSC/PAL, 480i/p, 720p, 1080i/p. The HDMI input also accepts VESA standards allowing the display to be used as a computer monitor. Adjustable color temperature enables the most precise color representation possible. Advanced features include aspect ratio settings, a variety of screen markers, underscan mode, blue-only mode, monochrome mode, H/V delay, Pixel-to-Pixel mode, and HDMI Input Format selection.

## Features

---

### ■ High-Resolution 7.0" Widescreen Panel

The V-LCD70P-HDMI features an all-digital TFT-MegaPixel active matrix LCD system with 1.2 million pixels. The LCD panel features a brightness of 250 cd/m<sup>2</sup> and a contrast ratio of 400:1 making the display ideal in a variety of environments and lighting conditions.

### ■ Multi-Format Compatibility

The V-LCD70P-HDMI accommodates many video standards with **Composite Video, YPbPr and HDMI** inputs. Accepted formats include NTSC/PAL, 480i/p, 576i/p, 720p, 1035i, 1080i, as well as VESA PC formats up to XGA (1024 x 768).

### ■ End-to-End Digital Signal Processing

Analog input signals are digitized using an advanced 10-bit process with 4x over-sampling, 5-line super-adaptive 2D comb filtering, and exacting color space conversion. Video is scaled to fit on the screen in the highest possible resolution using a state-of-the-art LSI that incorporates precision gamma correction and our HyperProcess motion adaptive interpolation for interlaced images.

### ■ ColorMatch Conversion with Color Temperature Adjustment

Emulation of SMPTE-C/EBU color space allows the V-LCD70P-HDMI to replace any broadcast CRT monitor. Presets include D55, D65 and D93. Bias and Gain adjustment for each color enables precise color matching and white balance.

### ■ Focus-Assist, False Color Filter, and other Advanced Features

Focus-Assist, False Color filter, Aspect ratio settings, underscan mode, blue-only mode, monochrome mode, and H/V delay are a few of the advanced features which make the V-LCD70P-HDMI at home in any broadcast environment. The HDMI Input allows display of incoming formats in the RGB or YCbCr color space. Pixel-to-Pixel mode also allows native display of any incoming image format.

### ■ Flexible Screen Markers

A variety of screen markers in 4:3, 16:9, and full screen modes allow accurate monitoring of the different aspect ratios used in broadcast environments.

### ■ User-Definable Function Buttons

Four user-definable function buttons on the front-panel allow quick access to numerous settings and features including focus-assist, false color filter, aspect ratio, screen markers, monochrome mode, color temperature, delay mode, and more.

### ■ User-Interchangeable Battery Adapters

Several battery adapter options accommodate a wide variety of professional batteries and camcorder batteries.

# Installation and Initial Setup

---

## ■ Unpacking

Carefully unpack the V-LCD70P-HDMI monitor and verify that the following items are included:

- V-LCD70P-HDMI Monitor
- V-PS12-5V-XLR Power Supply with 4-Pin Female XLR Connector
- Operating Instructions

Inspect the unit for any physical damage that may have occurred during shipping. Should there be any damage, immediately call Marshall Electronics Customer Service at (800) 800-6608. If you are not located within the continental United States, call +1 (310) 333-0606.

## ■ Mounting

The V-LCD70P-HDMI monitor features a ¼"-20 mounting hole on the underside of the enclosure, allowing the monitor to be mounted to a camera or other device using a variety of mounts.

## ■ Changing the Battery Adapter

The V-LCD70P-HDMI ships with a single battery adapter, specified at the time of ordering. Several other battery adapters are available to accommodate a variety of batteries.

- Six user-interchangeable "camcorder battery" adapters are available: **Canon**, **Panasonic**, **JVC**, **Sony BP**, **Sony NP-Q**, and **Sony NP-F**.

**Installation:** To uninstall one of the above battery adapters, remove the 5 screws on the adapter. Remove the adapter and carefully disconnect the 4-pin connector between the monitor and adapter. To install one of the above battery adapters, connect the 4-pin connector of the new battery adapter to the monitor, and re-install the 5 screws.

*Note: Do not change the pinout of the 4-pin connector on the battery adapter. This pinout is factory-configured according to each battery adapter.*

- **IDX** and **Anton Bauer** battery adapters are available, but must be factory installed. Contact Marshall Electronics Customer Service at (800) 800-6608 for further information.

## ■ Connections and Power-On

Plug the V-PS12-5V-XLR power supply into an AC power source (100-240 V @ 50/60 Hz). Attach the 4-pin female XLR connector to the back of the monitor. Please note that 12VDC can be also supplied directly to the monitor from a variety of sources. The monitor will draw no more than 1.0 Amps at 12 Volts in operation (12 Watts).

Connect the required cables for video signal input and output. (Power must be applied to the V-LCD70P-HDMI for the active loop-through outputs to be activated.) All BNC connectors are rated at 75Ω.

The unit defaults to 'ON' when power is supplied. Video will automatically be detected and displayed on the screen.

# Front and Side Panel Features

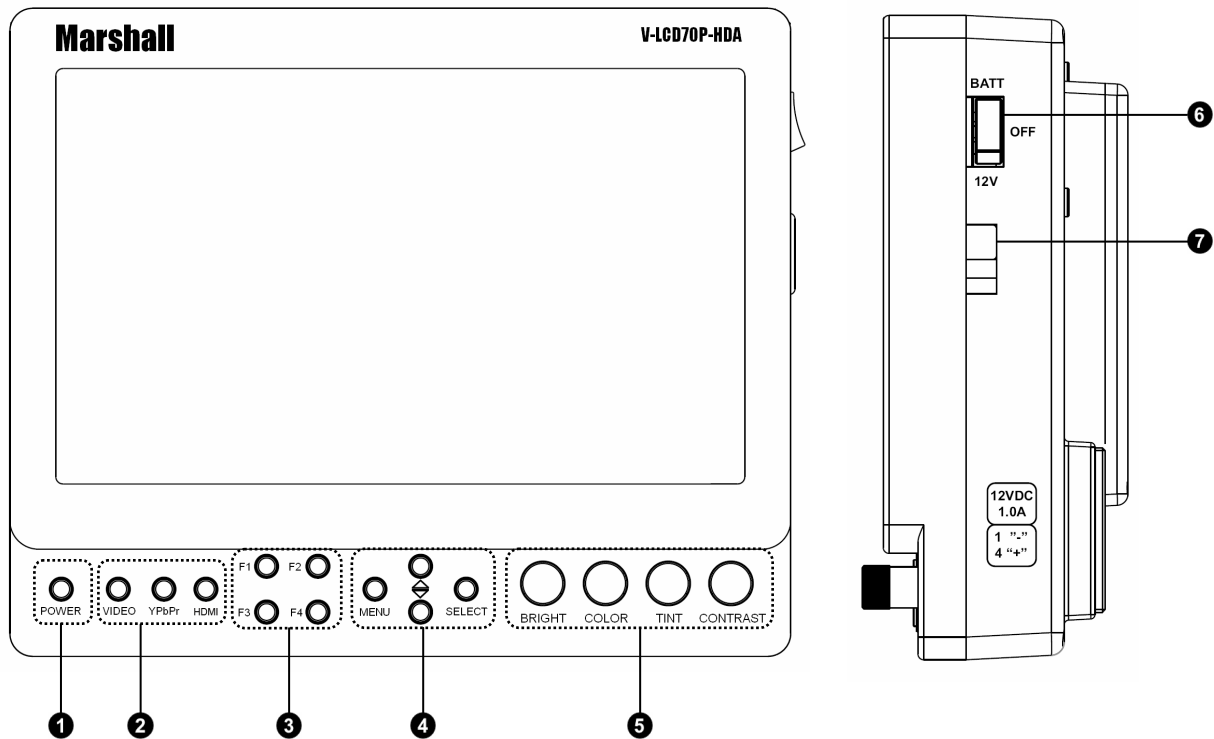

## 1 **Power Button**

Use the power button to toggle between ON and STANDBY modes. In the STANDBY state, the LED on the button will illuminate bright green. In the ON state, the LED will dimly illuminate green.

## 2 **Input Select Buttons**

Use the VIDEO, YPbPr, and HDMI buttons to select the corresponding analog or digital input. Video standards (NTSC/PAL, etc.) are automatically detected.

## 3 **User-Definable Function Buttons**

Four user-definable function buttons can be used for direct access to various settings. Functions are assigned using the on-screen menu (See **User-Definable Function Buttons – Page 17**).

## 4 **Menu Navigation Buttons**

Use the Menu, ▲, ▼, and **Select** buttons to display and navigate the on-screen menu (See **Main Menu and Navigation – Page 9**).

## 5 **Image Adjustment Knobs**

Use the image adjustment knobs to adjust color saturation, brightness and contrast of the image. The status of each image adjustment parameter is shown on the bottom left of the screen, with values ranging from 0 to 100. Default value is 50.

## 6 **Power Switch**

Use the hard power switch to supply power to the monitor, and choose the input from which the monitor draws power. The upper switch position uses the battery adapter, the lower switch position uses the XLR input, and the center position is OFF. Battery life can be preserved by setting this switch to the OFF position when the monitor is not in use.

## 7 **Service Connector**

This connector is for factory and future use.

# Rear Panel Features

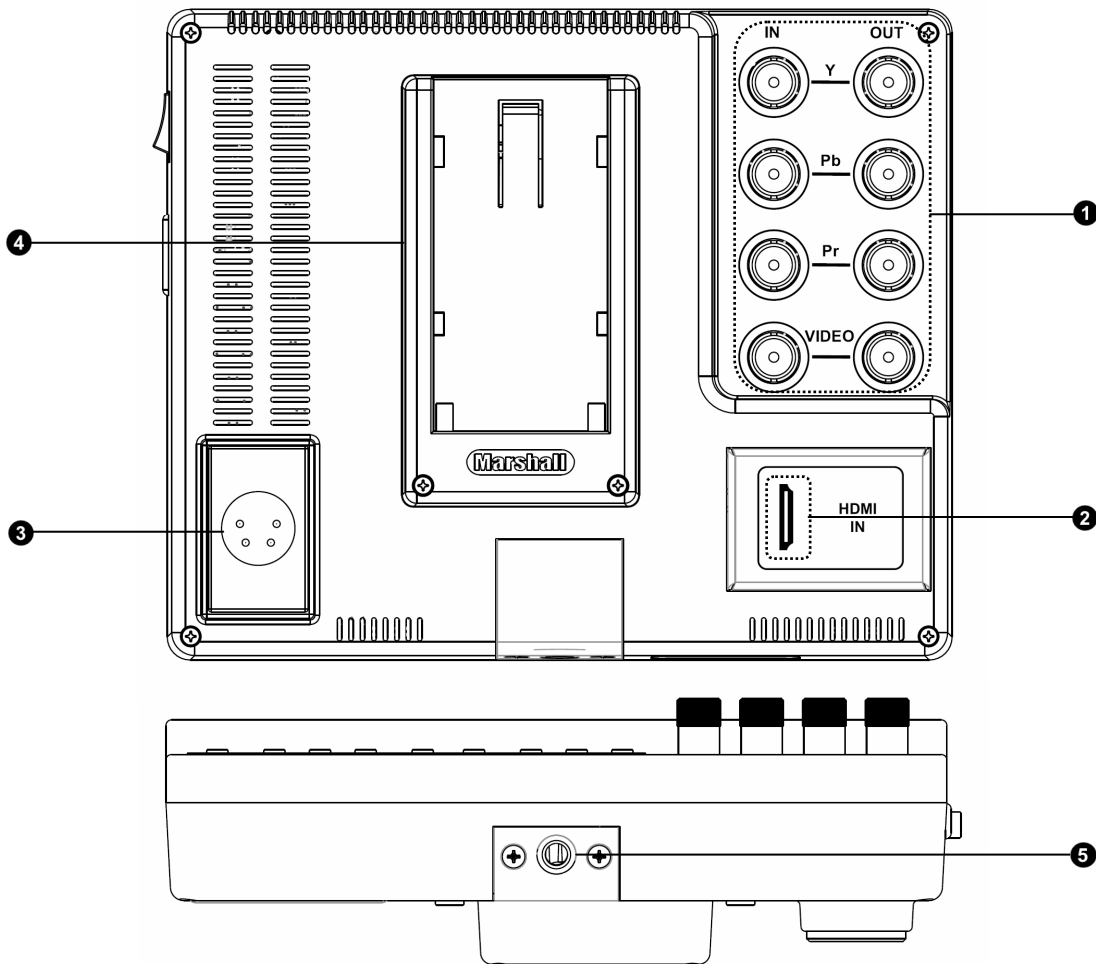

- 1 Component and Composite Input and Output**  
The V-LCD70P-HDMI has HD component (YPbPr), composite, and an HDMI input, as well as an active loop-through output for each analog input. See page 8 for supported video formats. The BNC inputs are internally terminated with 75 ohms.
- 2 HDMI Input Connector**  
Connect HDMI Sources here. Accepted input formats can be found on page 8.
- 3 Power Input**  
Connect 12VDC to the 4-Pin XLR power input connector. Power can be supplied from the included power supply, or from a variety of DC sources supplying at least 1 Amp at 12 Volts.

**IMPORTANT:** If using a power source other than the included power supply, be sure that the polarity of the DC input is correct:

- Pin 1: GND
- Pin 2: N/C
- Pin 3: N/C
- Pin 4: +12VDC

- 4 Battery Adapter**  
The V-LCD70P-HDMI can be powered from a variety of batteries. Several user-interchangeable battery adapters are available. See page 18 for available adapters.
- 5 1/4-20 Mounting Hole**  
Use the 1/4-20 mounting hole to attach the monitor to a camera or variety of mounting devices.

# Compatible Input Formats

---

Format	Composite	YPbPr	HDMI
NTSC	☺		
PAL	☺		
480i		☺	
576i		☺	
480p / 59.94		☺	☺
576p / 50		☺	☺
720p / 60		☺	☺
720p / 59.94		☺	☺
720p / 50		☺	☺
720p / 30		☺	☺
720p / 29.97		☺	☺
720p / 25		☺	☺
720p / 24			
720p / 23.98			
1035i / 60		☺	
1035i / 59.94		☺	
1080i / 60		☺	☺
1080i / 59.94		☺	☺
1080i / 50		☺	☺
1080psF / 24		☺	☺
1080psF / 23.98		☺	☺
1080p / 30		☺	☺
1080p / 29.97		☺	☺
1080p / 25		☺	☺
1080p / 24		☺	☺
1080p / 23.98		☺	☺
640 x 480 60 Hz			☺
640 x 480 72 Hz			☺
640 x 480 75 Hz			☺
800 x 600 56 Hz			☺
800 x 600 60 Hz			☺
800 x 600 72 Hz			☺
800 x 600 75 Hz			☺
1024 x 768 60 Hz			☺
1024 x 768 70 Hz			☺
1024 x 768 75 Hz			☺



# On-Screen Menu

## STRUCTURE OVERVIEW

Main Menu	Video Configuration	Color Temperature	D93, D65, D55, User
		RGB Bias and Gain	R, G, B Bias (0-100) / R, G, B Gain (0-100)
		Check Field	Off, Mono, Blue, Green, Red
		Ratio	Full Screen, 4:3, 16:9
		Pixel-to-Pixel	Off, On
		H/V Delay	Off, H & V Delay, V Delay, H Delay
		Underscan	Off, On
		NTSC Black Level	0 IRE, 7.5 IRE
	Marker Configuration	Markers	Off, On
		Center Marker	Off, On
		16:9 Markers	Off, 4:3, 13:9, 14:9, 1.85:1, 2.35:1, 95% Safe, 93% Safe, 90% Safe, 88% Safe, 85% Safe, 80% Safe
		Full Screen Markers	Off, 95% Safe, 93% Safe, 90% Safe, 88% Safe, 85% Safe, 80% Safe
		4:3 Markers	Off, 95% Safe, 93% Safe, 90% Safe, 88% Safe, 85% Safe, 80% Safe
		Marker Background	Normal, Black
	Filter Configuration	False Colors	Off, On
		Peaking Filter	Off, On
		Mosquito Filter	Off, On
	System Configuration	Input Format OSD	5 sec, Off, On
		Function on F1	Ratio, Check Field, Mosquito Filter, Peaking Filter, False Colors, Freeze Input, Aspect Markers, Center Marker, Markers, Underscan, H/V Delay, Pixel-to-Pixel
		Function on F2	Ratio, Check Field, Mosquito Filter, Peaking Filter, False Colors, Freeze Input, Aspect Markers, Center Marker, Markers, Underscan, H/V Delay, Pixel-to-Pixel
		Function on F3	Ratio, Check Field, Mosquito Filter, Peaking Filter, False Colors, Freeze Input, Aspect Markers, Center Marker, Markers, Underscan, H/V Delay, Pixel-to-Pixel
		Function on F4	Ratio, Check Field, Mosquito Filter, Peaking Filter, False Colors, Freeze Input, Aspect Markers, Center Marker, Markers, Underscan, H/V Delay, Pixel-to-Pixel
		Freeze Input	Freeze, Off
Manufacturer Default		Select	
HDMI Input		RGB, YCrCb	
Version Number Display		(Software Version Number Displayed)	

## MAIN MENU AND NAVIGATION

Access the main menu by pushing and holding the **MENU** button on the front panel of the monitor.

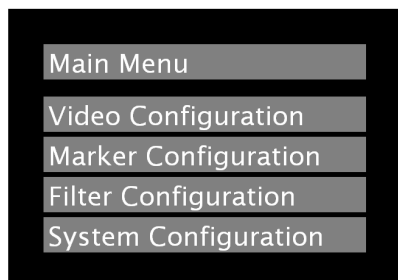

- Step through menu items using the ▲ and ▼ buttons.
- Choose a submenu or select a menu item by pressing **SELECT**.
- Return to the previous menu by pressing **MENU**.
- Exit the main menu by pressing **MENU**. The menu will automatically time out after about 15 seconds.

## VIDEO CONFIGURATION SUBMENU

Video Configuration	
Color Temperature	D65
RGB Bias and Gain	
Check Field	Off
Ratio	Full Screen
Pixel-to-Pixel	Off
H/V Delay	Off
Underscan	Off
NTSC Black Level	7.5 IRE

Video Configuration Submenu

### ■ Color Temperature

Use this setting to choose one of three color temperature presets:

- D55 (5500K)
- D65 (6500K)
- D93 (9300K)
- USER (Adjustable Color Bias and Gain)

### ■ RGB Bias and Gain

Select this submenu to fine-tune the monitor's color balance (R, G, B). This should only be done by someone experienced with video engineering, as this will alter the overall color shading of the screen. The purpose is to allow color matching to other types of monitors and/or displays. Note: The Color Temperature preset will automatically switch to USER when Color Bias settings are adjusted. It is normal for color bias adjustments to be very subtle.

When selecting the RGB Bias and Gain submenu, gain adjustment indicators will appear at the top of the screen, and bias adjustment indicators will appear at the bottom of the screen:

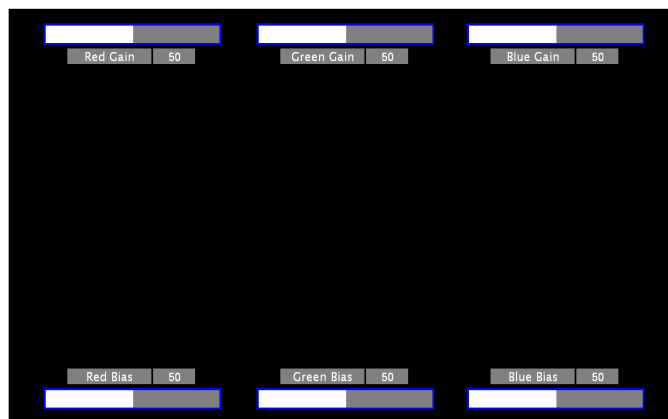

RGB Bias and Gain Submenu

Use the ▲ and ▼ buttons to select each individual bias or gain control. Press SELECT to begin adjusting the control. Use the ▲ and ▼ buttons to increase or decrease the value.

Alternately, the image adjustment knobs (Brightness, Color, Tint, Contrast) can be used to easily adjust the bias and gain settings as shown below. The knobs affect whichever row of controls (gain or bias) is currently selected.

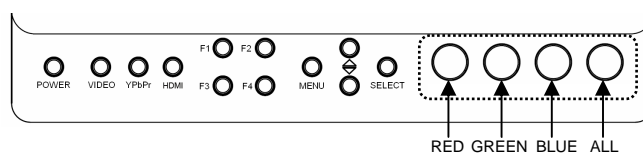

### VIDEO CONFIGURATION SUBMENU (continued)

#### ■ Check Field

Use the check field modes for monitor calibration or to analyze individual color components of an image. In Monochrome mode, all color is disabled and only a grayscale image is shown. In Blue, Green, and Red check field modes, only the selected color will be shown.

Use the following procedure when calibrating the monitor to SMPTE color bars with the following procedure:

1. Allow the monitor to warm up for at least 5-10 minutes.
2. Display SMPTE split-field color bars on the monitor using an external source.
3. Enable **Monochrome mode**.
4. Locate the pluge pattern (super black, black, and gray bars) at the lower-right corner of the screen. Adjust the **Brightness** knob until there is no visible difference between the super black and black bars, but the gray bar is still visible.
5. Adjust the **Contrast** knob until an even grayscale appears along the top bars.
6. Disable **Monochrome mode**.
7. Enable **Blue Check Field mode** and adjust the **Color** knob so that the outermost bars (white and blue) appear to match in brightness.
8. Composite NTSC only: Adjust the **Tint** knob until the third bar from the left (cyan) and the third bar from the right (magenta) appear to match in brightness.
9. Disable **Blue Check Field mode**.

#### ■ Aspect Ratio Settings

Use to switch between Full Screen, 4:3 and 16:9 aspect ratios.

As the V-LCD70P-HDMI monitor has a native resolution of 800 x 480 RGB pixels, incoming images are automatically scaled to fit the screen:

- In Full Screen, images are scaled to fill the entire 15x9 screen.
- In 4:3 mode, images are scaled to fill the maximum 4:3 portion of the screen (640 x 480), with black bars filling the remainder of the screen.
- In 16:9 mode, images are scaled to fill the maximum 16:9 portion of the screen (800 x 450), with black bars filling the remainder of the screen.



Full Screen



4:3 Mode



16:9 Mode

Note: The aspect ratio setting is ignored when Pixel-to-Pixel mode is enabled.

### VIDEO CONFIGURATION SUBMENU (continued)

#### ■ Pixel-to-Pixel Mode

Use this setting to enable Pixel-to-Pixel mode.

This mode bypasses the monitor's internal scaling function and displays incoming images in their native resolution and aspect ratio, with a one-to-one mapping:

- For incoming formats smaller than the native resolution of the LCD panel (800 x 480), the image will be displayed in the center of the screen using only the necessary LCD pixels. For example, NTSC images will occupy exactly 720 x 480 pixels. The surrounding pixels will be black.
- For incoming formats exceeding 800 x 480 pixels, only the center 800 x 480 of the incoming image will be displayed occupying the whole screen, with the remainder of the picture cropped. For example, 1080i formats will both be cropped to 800 x 480 and displayed full-screen.

Note: Pixel-to-Pixel mode disables aspect ratio control and H/V Delay.

#### ■ H/V Delay

Use this setting to enable one of three delay modes (H & V Delay, V Delay, H Delay):

- In H & V Delay mode, both horizontal sync and vertical sync are delayed, resulting in both horizontal and vertical blanking periods being shown on the screen.
- In V Delay mode, vertical sync is delayed so that the vertical blanking period is displayed on screen.
- In H Delay mode, horizontal sync is delayed so that the horizontal blanking period is displayed on the screen.

#### ■ Underscan

Use this setting to enable or disable Underscan mode:

- When Underscan is OFF, the active portion of the video signal is displayed on the screen, with 0% overscan.
- When Underscan is ON, the image size is slightly reduced. This allows the user to clearly view the edges of the active video area.

#### ■ NTSC Black Level

Set the NTSC Black Level according to the type of NTSC composite video input:

- 7.5 IRE: Use this setting for standard NTSC-M signals which use a 7.5 IRE setup (black level).
- 0 IRE: Use this setting for NTSC-J signals which have no setup, or a black level of 0 IRE.

Note: This setting is disabled for PAL composite input and all component/HDMI formats.

## MARKER CONFIGURATION SUBMENU



Marker Configuration	
Markers	On
Center Marker	Off
16:9 Marker	Off
Full Screen Markers	Off
4:3 Markers	Off
Marker Background	Normal

*Marker Configuration Submenu*

### ■ Markers

Use this setting to enable or disable all on-screen markers. This setting affects the center marker, full screen markers, 16:9 markers, and 4:3 markers.

### ■ Center Marker

Use this setting to display a center marker on the screen.

### ■ 16:9 Markers

Use these settings to superimpose one of 11 markers on the screen when in 16:9 mode.

- 4:3
- 13:9
- 14:9
- 1.85:1
- 2.35:1
- 95% Safe
- 93% Safe
- 90% Safe
- 88% Safe
- 85% Safe
- 80% Safe

#### 16:9 Marker Examples:



*OFF (No Marker)*



*2.35:1 Aspect Ratio*



*4:3 Aspect Ratio Marker*



*90% Safe Area*

## MARKER SETUP SUBMENU (continued)

### ■ 4:3 Markers / Full Screen Markers

Use this setting to superimpose one of 5 markers on the screen when in 4:3 or Full Screen mode. This setting is disabled when the aspect ratio is set to 16:9, or when Pixel-to-Pixel, Underscan, or H/V Delay is enabled.

- 95% Safe Area
- 93% Safe Area
- 90% Safe Area
- 88% Safe Area
- 85% Safe Area
- 80% Safe Area

#### 4:3 Marker Examples:

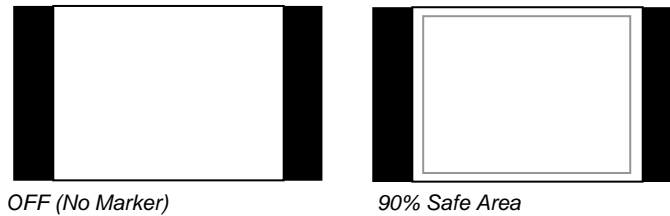

### ■ Marker Background

Use this setting to choose how selected markers are displayed on the screen:

- Normal     The marker is superimposed on the complete image.
- Black      Image area beyond the marker is shown at 0% intensity (black).

#### Example (80% Marker in 4:3 Mode):

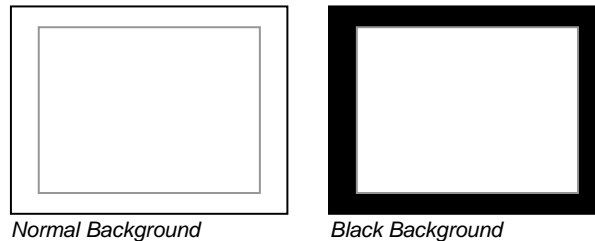

## FILTER CONFIGURATION SUBMENU

### ■ False Colors

This monitor has a false color filter to aid in the setting of camera exposure. As the camera Iris is adjusted, elements of the image will change color based on the luminance or brightness values. This enables proper exposure to be achieved without the use of costly, complicated external equipment. To best utilize this feature, you must understand the color chart below and have a basic understanding of camera exposure. Normally, when shooting subjects like people, it is common practice to set exposure of faces to the equivalent of approximately 56 IRE. The false color filter will show this area as the color PINK on the monitor. Therefore, as you increase exposure (open the IRIS), your subject will change color as indicated on the chart: PINK, then GREY, then a few shades of YELLOW. Over exposed subjects (above 101 IRE) on the monitor will be shown as RED. In addition, underexposed subjects will show as DEEP-BLUE to DARK-BLUE, with clipped-blacks indicated with a FUCHSIA-like color. Lastly, the color GREEN is used to indicate elements of the image that are approximately 45 IRE. This represents a 'neutral' or 'mid-level' exposure commonly used for objects (not people).

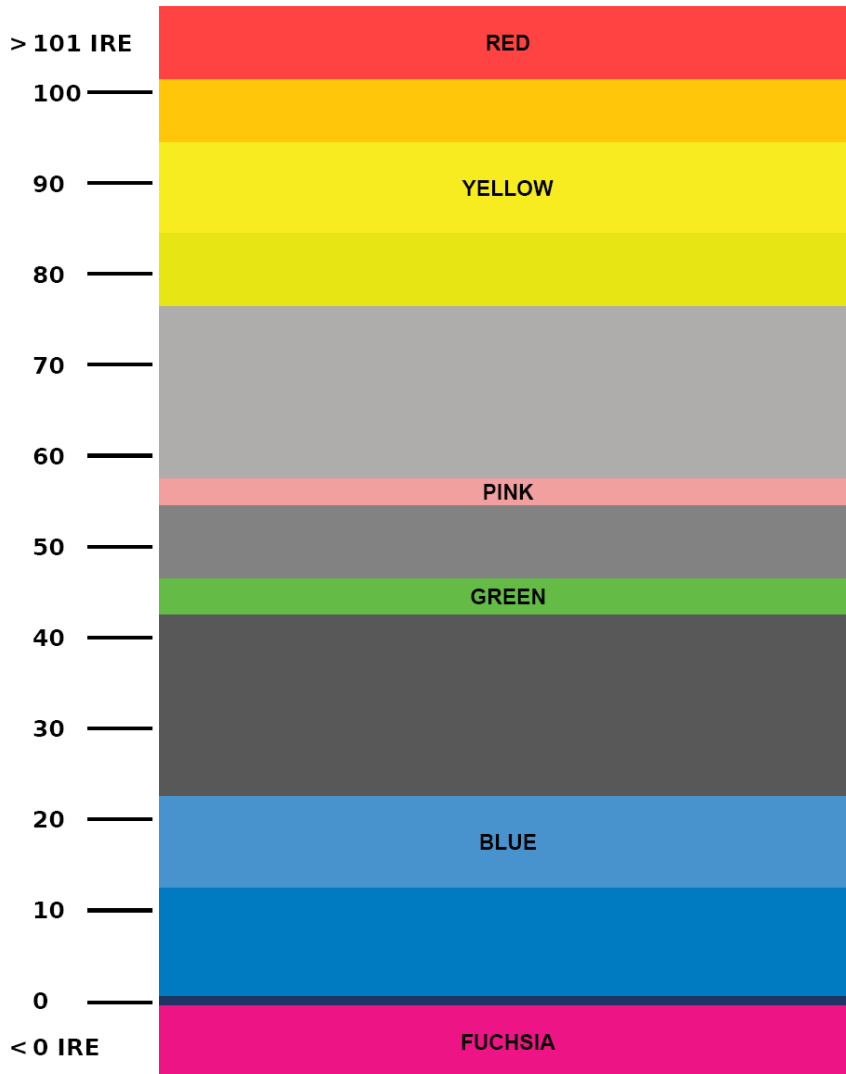

*False Color Key*

### FILTER CONFIGURATION SUBMENU (continued)

#### ■ Peaking Filter (Focus assist)

The Peaking Filter is used to aid the camera operator in obtaining the sharpest possible picture. When activated, all color will be removed from the display and a black-and-white image will remain. The internal processor will display RED color on the screen where sharp edges appear. When the camera operator adjusts (racks) the focus control (on the camera lens), different parts of the image will have RED colored edges. This indicates that the portion of the image is sharp – or in focus. Final focus is achieved by racking the camera lens focus control back and forth until the desired portion of the image has RED colored edges. Please note that this feature is most effective when the subject is properly exposed and contains enough contrast to be processed.

#### ■ Mosquito Filter

Use this setting to filter out “Mosquito Noise” – an artifact that appears as specs around edges of objects. This artifact is the result of video that has been compressed at some point. Video sources from DVD-Players, PDA's, Digital Cable Boxes, Camcorders, etc. often have this artifact.



### SYSTEM CONFIGURATION SUBMENU

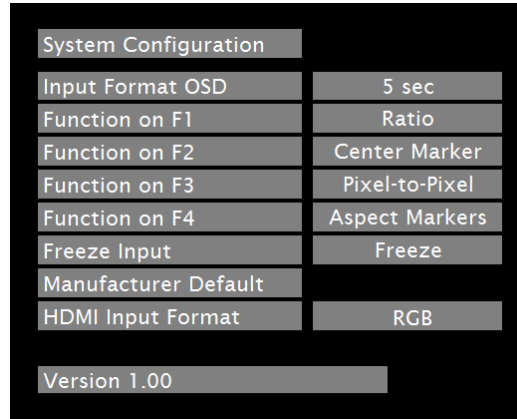

*System Configuration Submenu*

#### ■ Input Format OSD

Use this option to enable on-screen display of input/format status in the upper-left corner of the screen.

#### ■ User-Definable Function Buttons

Use the **Function on F1, F2, F3 and F4** menu items to define each function button on the front panel of the monitor. The following options are available for each button:

- Ratio
- Check Field
- Mosquito Filter
- Peaking Filter
- False Colors
- Freeze Input
- Aspect Markers
- Center Marker
- Markers
- Underscan
- H/V Delay
- Pixel-to-Pixel

#### ■ Freeze Input

Use the Freeze function to “freeze” the current image on the screen. Select this menu item again (Off) to return to the real-time video input.

#### ■ Manufacturer Default

Select this menu item to reset all adjustments and menu settings to the factory default configuration.

#### ■ HDMI Input Format

Use this setting to select the color space (RGB or YCrCb) of incoming HDMI video. This should match the color space of the video output settings on your playback device. Note that this option is disabled when viewing VESA (Computer) formats.

# Specifications

## ■ PANEL

Screen Size	7.0" Diagonal
Display Area (h x v)	152.40 x 91.44 mm
Aspect Ratio	15:9 (16:9 / 4:3 Selectable)
Pixels	800 x 480
Color Depth	18-bit (262,144 Colors)
Viewing Angle (h x v)	140° x 100° (CR >10)
Brightness	250 cd/m <sup>2</sup>
Contrast Ratio	400:1
Dot Pitch (h x v)	0.0635 x 0.1905 mm
Pixel Pitch (h x v)	0.1905 x 0.1905 mm

## ■ VIDEO INPUT/OUTPUT

### Video Input / Output

Supports SMPTE 170M, NTSC/PAL

### YP<sub>B</sub>P<sub>R</sub> Input / Output

Supports SMPTE 260M, 274M, 296M

### HDMI Input

HDMI 1.2, VESA Graphics Modes

## ■ CONNECTORS

### Video Input

Video	1 x BNC Female (75 Ω)
YP <sub>B</sub> P <sub>R</sub>	3 x BNC Female (75 Ω)

### HDMI Input

HDMI	1 x HDMI (Type A) Female
------	--------------------------

### Video Output (Active Loop-Through)

Video	1 x BNC Female (75 Ω)
YP <sub>B</sub> P <sub>R</sub>	3 x BNC Female (75 Ω)

### Power Input

4-Pin Male XLR

Pin 1:	GND
Pin 2:	N/C
Pin 3:	N/C
Pin 4:	+12VDC

## ■ ELECTRICAL

Power Consumption	1 Amp (Max) @ 12VDC (12 W Max)
Voltage Requirement	12VDC (10VDC-18VDC)

### V-PS12-5V-XLR Power Supply:

Input	100V-240V, 1.5A, 50-60Hz
Output	12VDC, 5A, 60W Max

## ■ BATTERY ADAPTER

Field-Interchangeable Battery Adapter Options  
(Sold Separately):

Marshall Adapter	Battery Type	Battery Voltage	Recommended Battery
CM	Canon	7.4 V	Canon BP-970G
PM	Panasonic	7.2 V	Panasonic CGA-D54
JM	JVC	7.2 V	JVC BN-V438U
SB	Sony BP	14.4 V	Sony BP-460
SM	Sony NP-Q	7.2 V	Sony NP-QM91
SL	Sony NP-F	7.2 V	Sony NP-F970

Factory Configured Battery Adapter Options:

Marshall Adapter	Battery Type	Battery Voltage	Recommended Battery
IDX	V-Mount	14.4 V	IDX E7S
AB	Anton Bauer	14.4 V	Anton Bauer Hytron 50

## ■ MECHANICAL

Dimensions (w x h x d): 6.85" x 5.67" x 1.95"

Additional Mounting: ¼"-20 Mounting Bracket

Weight (Monitor Only):	1.55 lbs
Operating Temperature	32°F to 95°F (0°C to 35° C)
Storage Temperature	-4°F to 104°F (-20°C to 40° C)

RoHs Do not dispose. Return to Manufacturer or Authorized Recycle Facility.

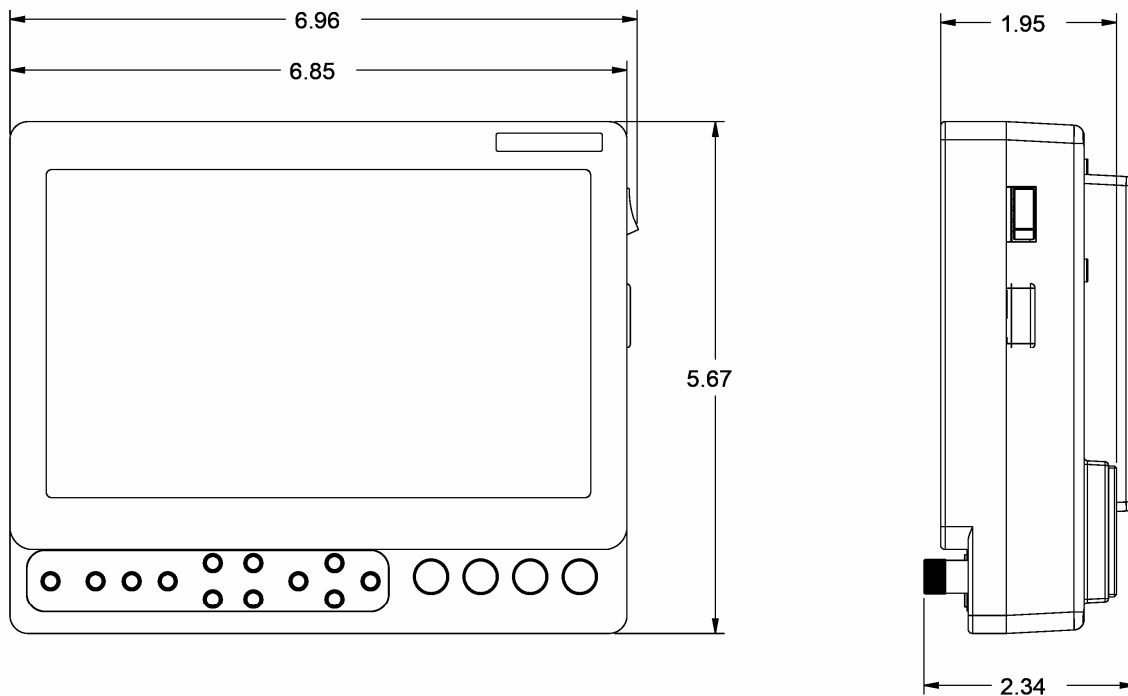

## Maintenance

### ■ Screen Cleaning

Periodically clean the screen surface using ammonia-free cleaning wipes (Marshall Part No. **V-HWP-K**). A clean micro-fiber cloth can also be used using only non-abrasive and ammonia-free cleaning agents. Do not use paper towels. Paper towel fibers are coarse and may scratch the surface of the polycarbonate faceplate or leave streaks on the surface. Antistatic and fingerprint resistant cleaning agents are recommended. Do not apply excessive pressure to the screen to avoid damaging the LCD.

### ■ Faceplate Dusting

Dust the unit with a soft, damp cloth or chamois. Dry or abrasive cloths may cause electrostatic charge on the surface, attracting dust particles. Neutralize static electricity effects by using the recommended cleaning and polishing practice.

## Warranty

Marshall Electronics warrants to the first consumer that this **V-LCD70P-HDMI** LCD monitor will, under normal use, be free from defects in workmanship and materials, when received in its original container, for a period of one year from the purchase date. This warranty is extended to the first consumer only, and proof of purchase is necessary to honor the warranty. If there is no proof of purchase provided with a warranty claim, Marshall Electronics reserves the right not to honor the warranty set forth above. Therefore, labor and parts may be charged to the consumer. This warranty does not apply to the product exterior or cosmetics. Misuse, abnormal handling, alterations or modifications in design or construction void this warranty. *It is considered normal for a minimal amount of pixels, not to exceed three, to fail on the periphery of the display active viewing area.* Marshall Electronics reserves the option to refuse service for display pixel failure if deemed unobtrusive to effective use of the monitor by our technicians. No sales personnel of the seller or any other person is authorized to make any warranties other than those described above, or to extend the duration of any warranties on behalf of Marshall Electronics, beyond the time period described above. Due to constant effort to improve products and product features, specifications may change without notice.

**Marshall Electronics, Inc.**

1910 East Maple Ave.

El Segundo, CA 90245

Tel: (800) 800-6608 / (310) 333-0606 • Fax: 310-333-0688

[www.LCDRacks.com](http://www.LCDRacks.com) • [sales@lcdracks.com](mailto:sales@lcdracks.com)

2009-0311b