

# Installation

**TDB3104**



**Terreon® 54" Semi-Circular Deep Bowl Washfountain with Air Metering Valve**

**WF3204**

**Terreon® Extra Height 54" Semi-Circular Classic Washfountain with 9" Deep Bowl and Air Metering Valve**

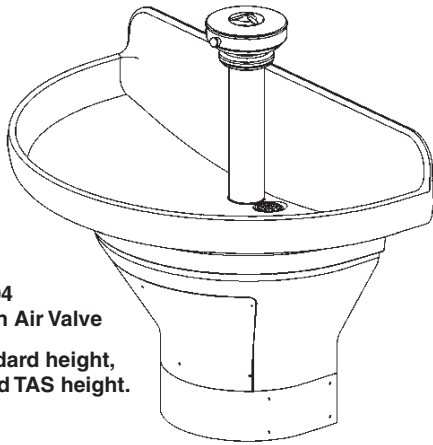

**TDB3104**  
with Push Button Air Valve  
Available in standard height,  
juvenile height, and TAS height.

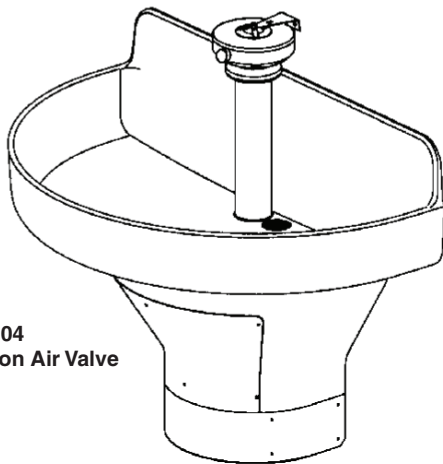

**WF3204**  
with Push Button Air Valve

## Table of Contents

Pre-Installation Information . . . . .	2
Semi-Circular Washfountain Dimensions . . . . .	3-4
Rough-In Specifications . . . . .	5-6
Installing the Drain . . . . .	7
Bowl/Pedestal Mounting and Assembly . . . . .	8
Installing Drain Spud in Bowl . . . . .	8
Connect Supply Tubing to Sprayhead . . . . .	9
Air Metering Valve Assembly . . . . .	10-13
Valve and Tubing Connections . . . . .	14
Adjust the Temperature . . . . .	15
Cleaning and Maintenance . . . . .	16-17
Soap Valve Parts List and Maintenance . . . . .	18-19
Sprayhead Parts List and Troubleshooting . . . . .	20
Actuator Module Assembly Components . . . . .	21
Metering Air Valve Maintenance . . . . .	22
Navigator® Mixing Valve Maintenance . . . . .	23



## IMPORTANT!

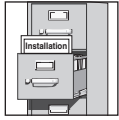

Read this entire installation manual to ensure proper installation. When finished with the installation, file this manual with the owner or maintenance department.



Separate parts from packaging and make sure all parts are accounted for before discarding any packaging material. If any parts are missing, do not begin installation until you obtain the missing parts.

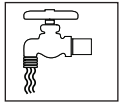

Make sure that all water supply lines have been flushed and then completely turned off before beginning installation. Debris in supply lines can cause valves to malfunction.

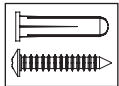

Hardware supplied by installer must be appropriate for wall construction. Wall anchors used must have a minimum pull-out rating of 1,000 lbs.



Product warranties may be found under "Product Information" on our web site at [www.bradleycorp.com](http://www.bradleycorp.com).

## Supplies Required by Installer

- (4) 1/2" lag bolts, screws or other fasteners to anchor washfountain pedestal
- 1/2" nominal copper tubing for hot and cold water supply lines.
- Standard P-trap (vented trap supplied by Bradley when required)
- 2" drain lines and fittings
- 1-1/2" vent or tie pipe on fixtures vented through washfountain column
- Teflon tape or pipe dope

## Pre-Installation Information

### Terreon® Material

The Washfountain is constructed of Terreon®, a densified solid surface material composed of polyester resin. Terreon is resistant to chemicals, stains, burns and impact. Surface damage can be easily repaired with everyday cleaners or fine-grit abrasives. Terreon is NAHB certified to meet ANSI Z124.3, Z124.6 and ANSI/ICPA SS-1-2001.

### Cylindrical air valve

The air valve pushbutton allows each user to activate an air metering valve (starting the flow of water) by pushing and releasing the pushbutton. The air metering valve is factory-preset to run for 10 seconds and can be adjusted to run from 5-60 seconds.

# Semi-Circular Washfountain Dimensions

## Model TDB3104

### 54" Semi-circular - side view

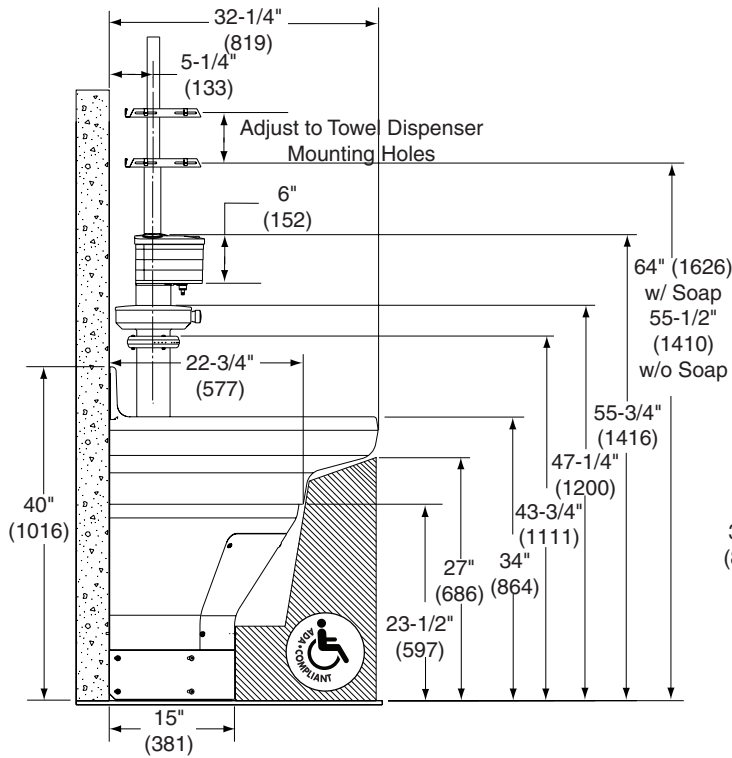

## Model TDB3104 (Juvenile Height)

### 54" Semi-circular - side view

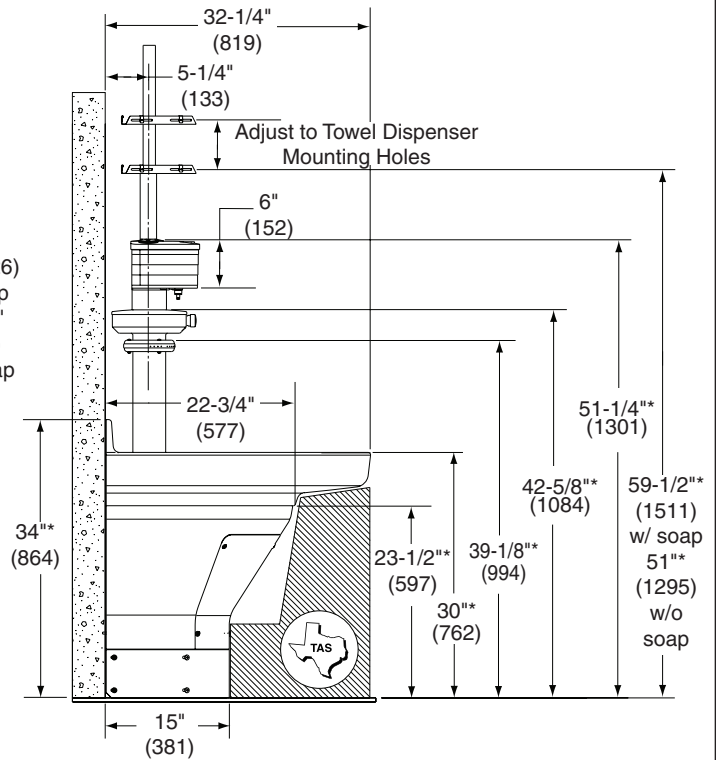

Model TDB3104 is ADA Compliant

Optional equipment may not comply with all ADA dimensional guidelines

\* Add 2" (51) for TAS height unit

## Model TDB3104

### 54" Semi-circular - rear view pedestal access

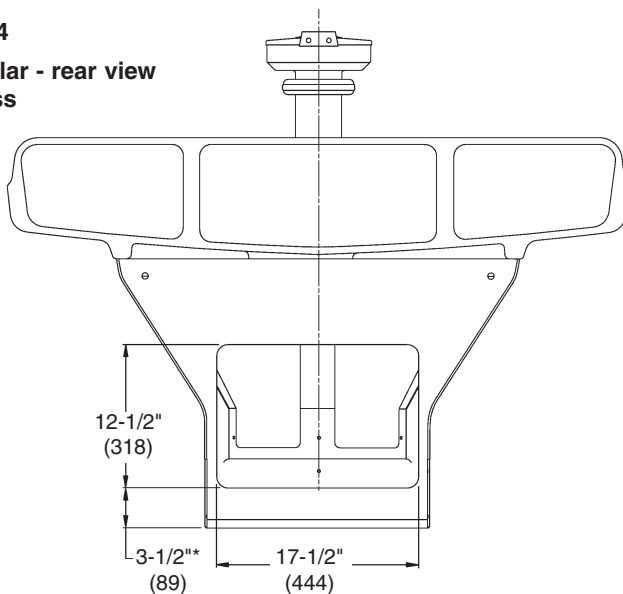

# Semi-Circular Washfountain Dimensions

Model WF3204

54" Semi-circular - side view

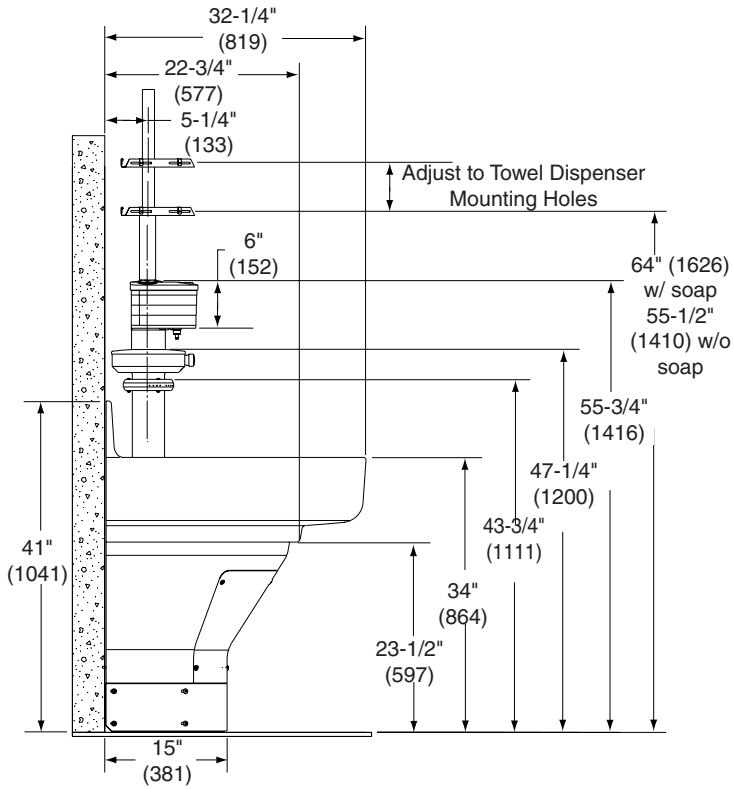

Model WF3204 is not ADA compliant

# Rough-In Specifications

(mm)

## Type A Drain

- Supplies from below or through wall
- Vent from below or through wall off-drain

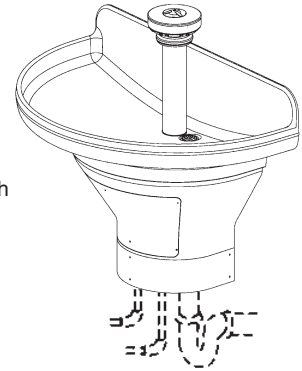
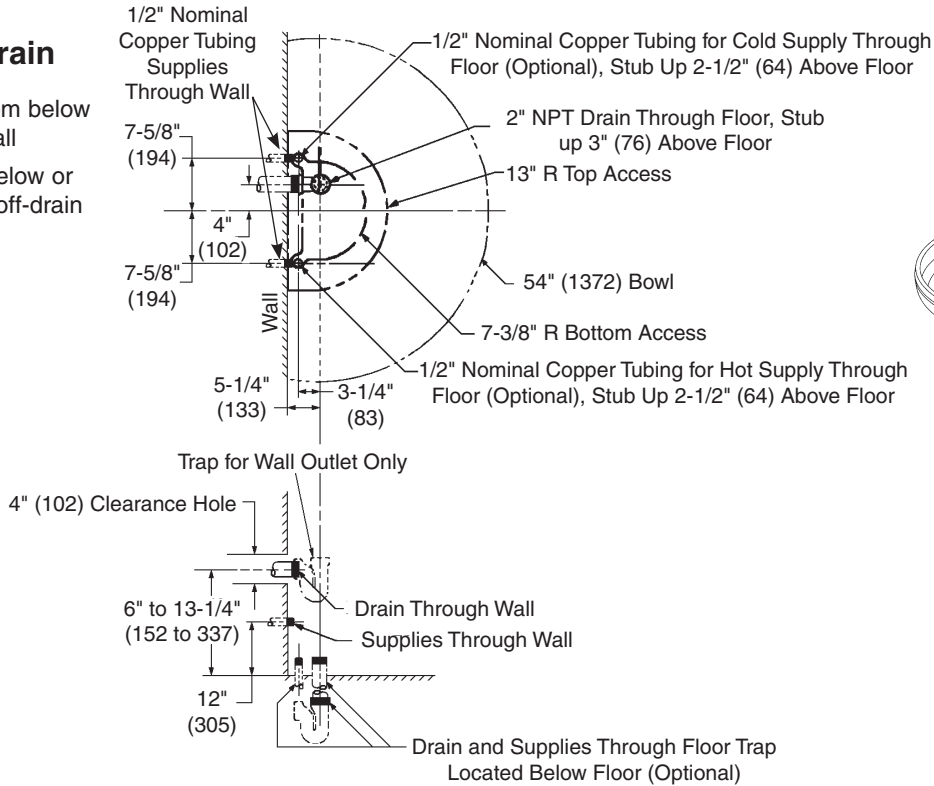

## Type B Drain

- Supplies from above
- Vent through ceiling off trap inside pedestal

(mm)

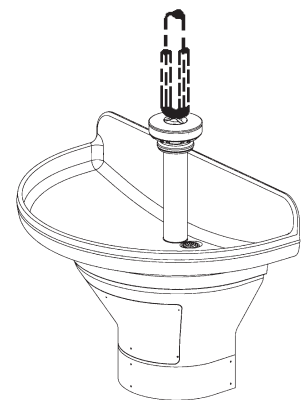
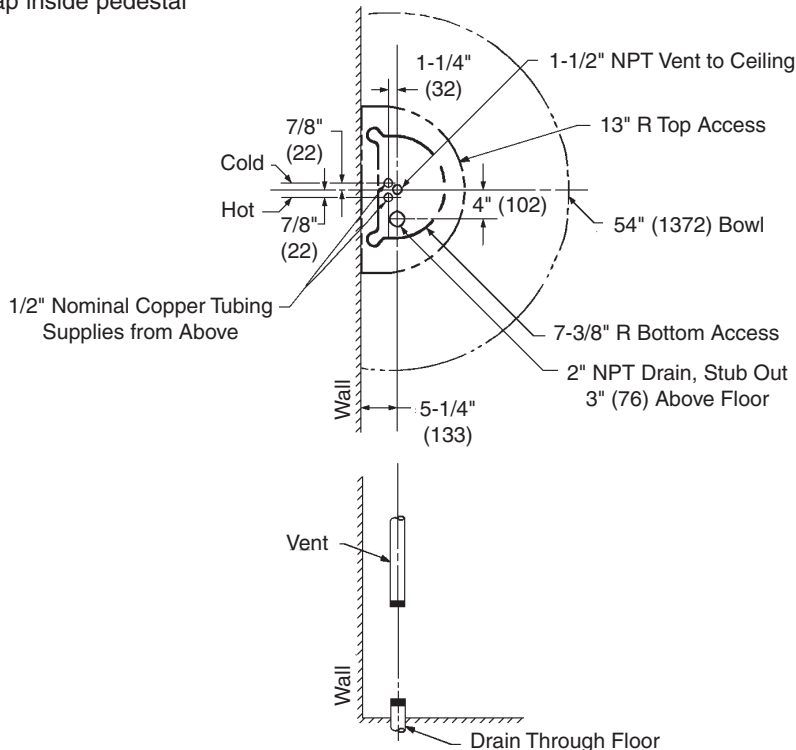

# Rough-In Specifications

(mm)

## Type H Drain

- Supplies from below or through wall
- Vented through ceiling off trap inside pedestal

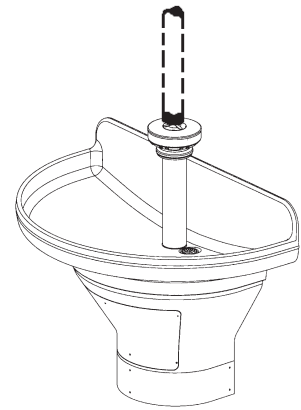
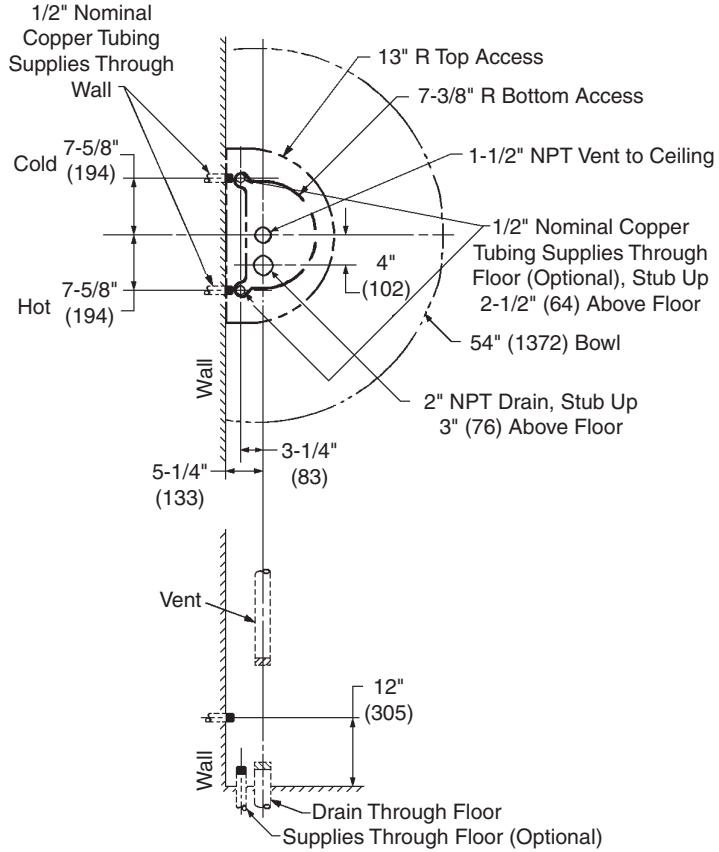

## Type O Drain

- Supplies from above
- Vented from below or through wall off drain

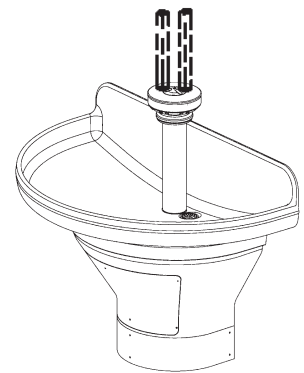
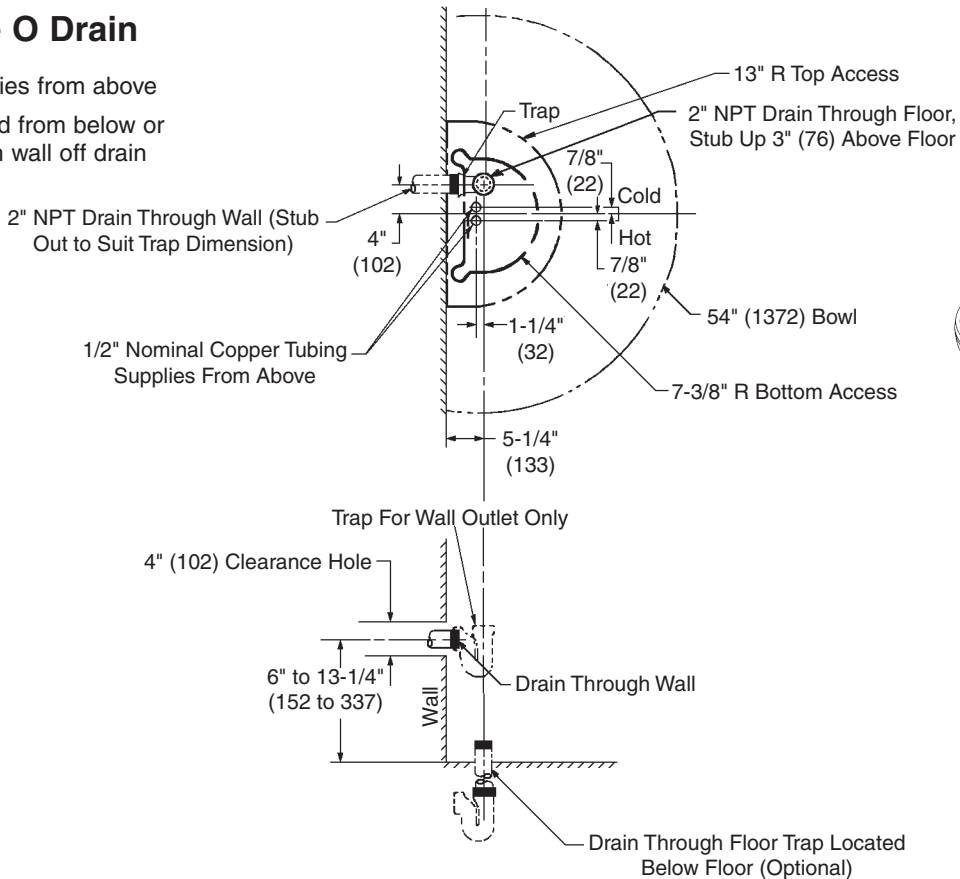

(mm)

# 1 Installing the Drain



All piping shown in dotted lines to be supplied by installer.

**A** Rough in supply and drain piping as required for your installation.

**B** Assemble the drain to the dimension for the bowl you are installing.

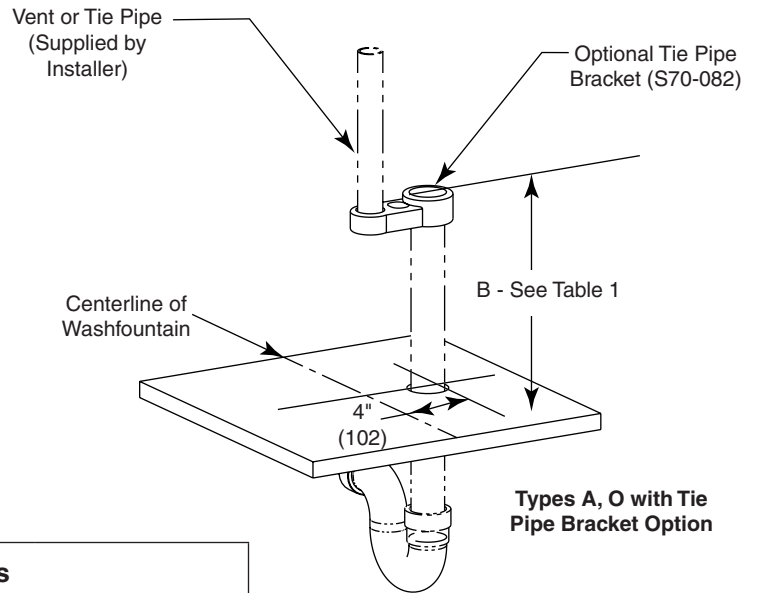
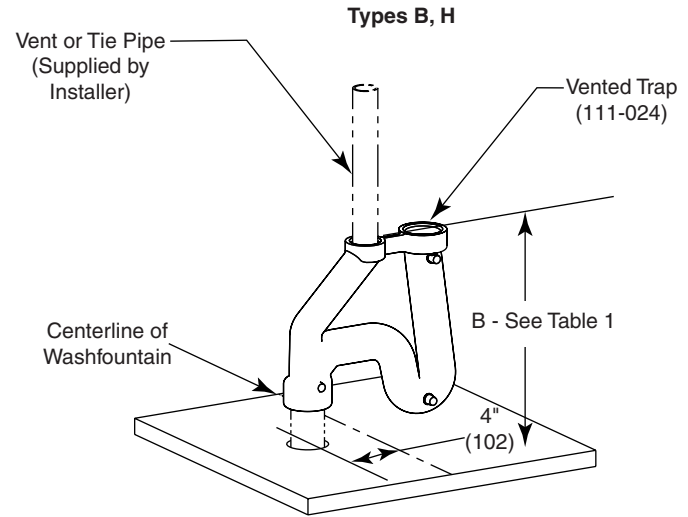
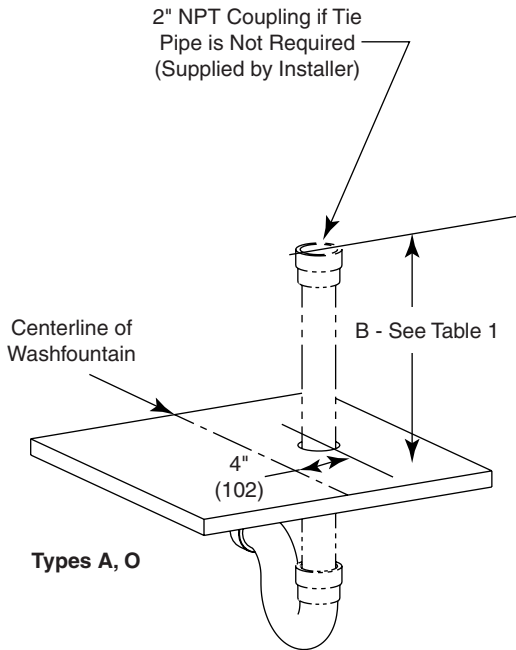

See Rough-In information for dimensions not shown.

**Table 1 — “B” Trap Dimensions**

Dim	Standard Height	Juvenile Height	TAS
B	23-3/8" (594mm)	22-1/2" (572mm)	24-1/2" (622mm)

## 2 Bowl/Pedestal Mounting and Assembly

**A** Position the pedestal at desired location and mark the position of the (2) pedestal wall mounting locations and (2) pedestal floor mounting locations.

TAS OPTION: Place TAS spacer on floor over the mounting holes. Place pedestal on top of the spacer.

**B** Secure pedestal to wall and floor with suitable fasteners, 1/2" anchors and bolts (supplied by installer).

**C** Using two to three people, carefully lift bowl onto pedestal.

**D** Position the bowl so that the threaded rods in the bowl mate with the slotted holes in the pedestal.

**E** Using 1/4" wing nuts and washers, secure the bowl to the pedestal, three places.

**CAUTION!** Bowl surface is very smooth. Approximate weight of bowl is 146 pounds (model TDB3104), 136 pounds (model WF3204) or 101 pounds (model TDB3104/JUV). Handle with Care!

Top View

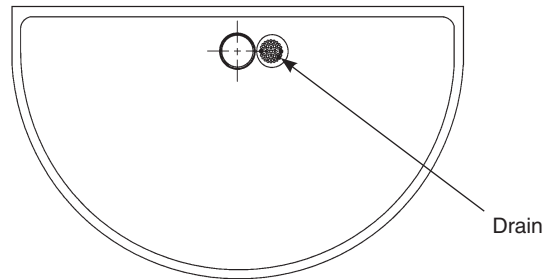

Front View

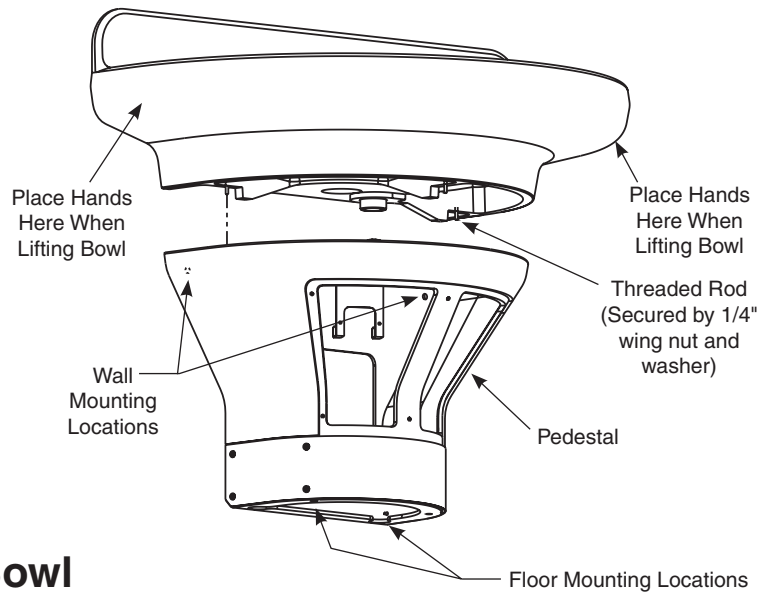

## 3 Installing Drain Spud in Bowl

**A** Loosely attach the drain spud to the bowl with the locknut and washer.

B TRAP OPTION: attach B trap to drain spud

Tie Pipe OPTION: attach tie pipe bracket to drain spud.

**B** Tighten the spud and lock nut against the bowl.

**C** Secure the strainer to drain spud with the screws provided.

**D** Connect spud (or B Trap or Tie Pipe Bracket) to drain.



Seal between drain spud and drain hole with plumber's putty (supplied by installer).

Drain Pre-Pack (S45-273)

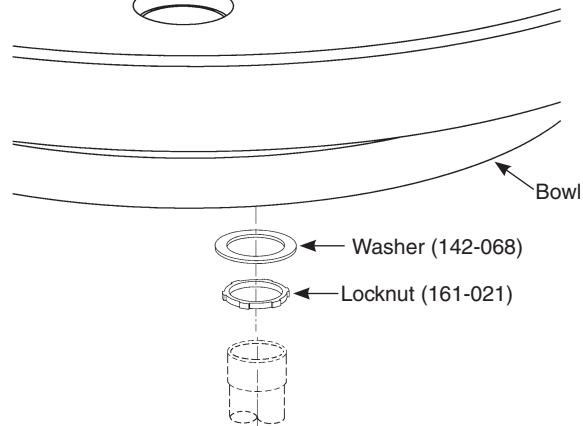
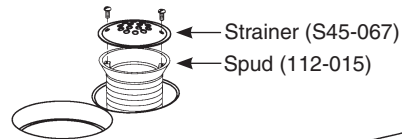



## 4 Connect Supply Tubing to Sprayhead

Install 3/8" supply tubing in the sprayhead using the male connector.

- Using a sharp razor, cut tubing squarely and remove any burrs. DO NOT pinch or crush end of tubing.
- Loosen nut on fitting. Moisten end of tube and push into fitting until it is firmly seated. Tighten nut to secure tube to fitting (make sure nut is securely tightened).
- If connector leaks, reseal tubing. If leaking persists, replace male connector, or call your Bradley representative for assistance.

**A**

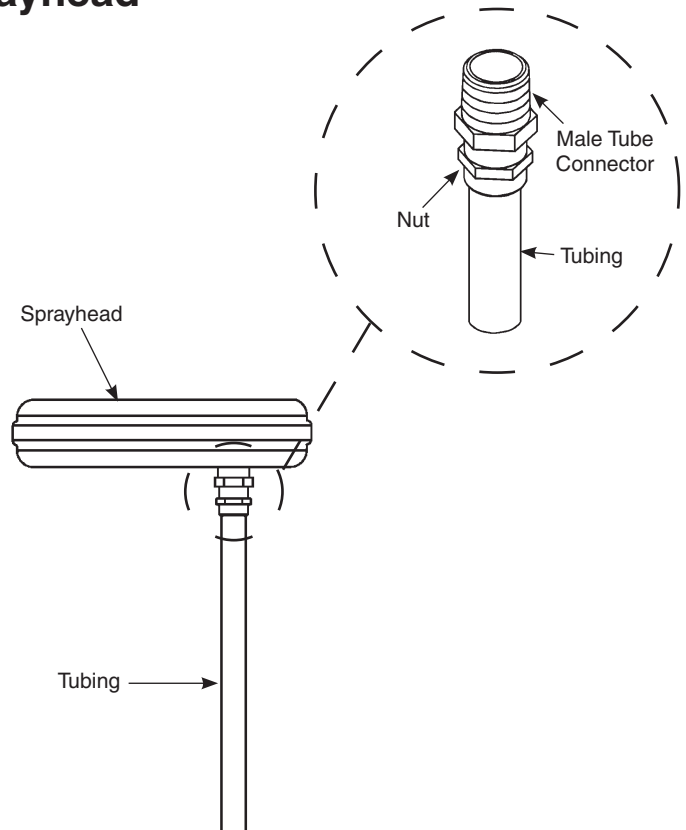

# 5a Air Metering Valve Assembly for A Drain and O Drain Units without Tie Pipe Option

**A** Install hemmed end (not sharp end) of support tube with gasket onto bowl.

**B** Place sprayhead with 3/8" tubing onto support tube. Run the tubing down through the support tube and connect to valve tube connector. Make sure the spray holes point away from the wall.

**C** Place the upper tie bar (notched at both corners of each end) on top of sprayhead parallel to wall. Connect the longer tie rod to the 4-1/4" tie rod using the coupling nut with hex head set screws. Run the tie rod assembly down through upper tie bar and secure from underneath the bowl using lower tie bar (no notches) and hex nut with socket head set screw.

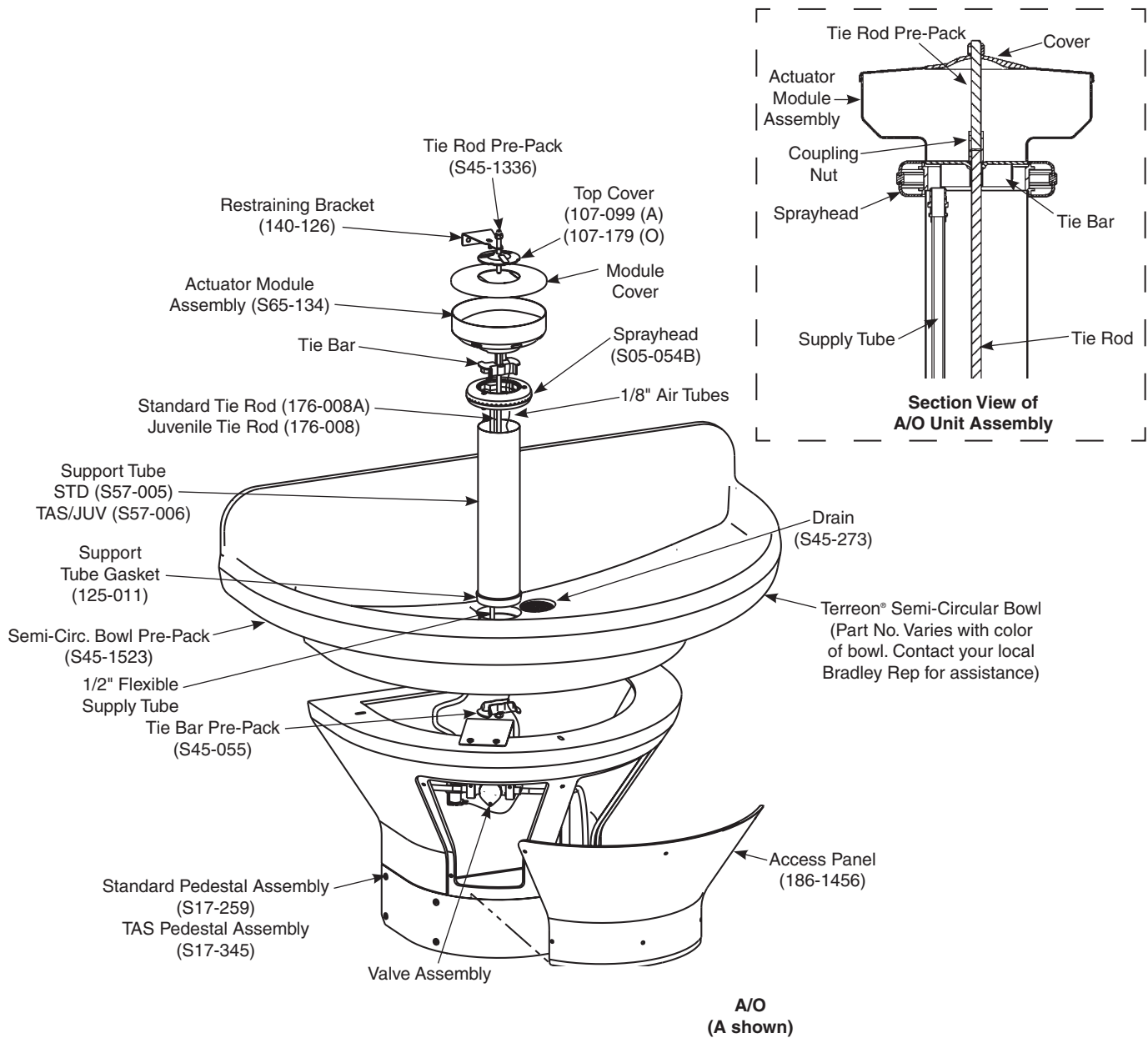

# 5a Air Metering Valve Assembly for A Drain and O Drain Units without Tie Pipe Option *continued...*

**D** Place the actuator module assembly on top of sprayhead. Rotate until actuator module locks in with tie bar. Drop 1/8" diameter tube down to valve assembly and connect to the air valve. Make sure air valve push button is facing away from the wall.

 Skip to step F for units without soap.

**E** For units with soap option, install the spacer, soap dispenser and cover using the third tie rod (8-5/8" long) and second coupling nut as shown. Secure with acorn nut and set screw.

**F** Secure actuator module cover and top cover with sprayhead restraining bracket, acorn nut and set screw.

**G** Connect supply stops onto stub-outs. Connect flexible hoses to supply stops.

Unit with "O" Drain and Actuator Module Shown, Also Available with "A" Drain

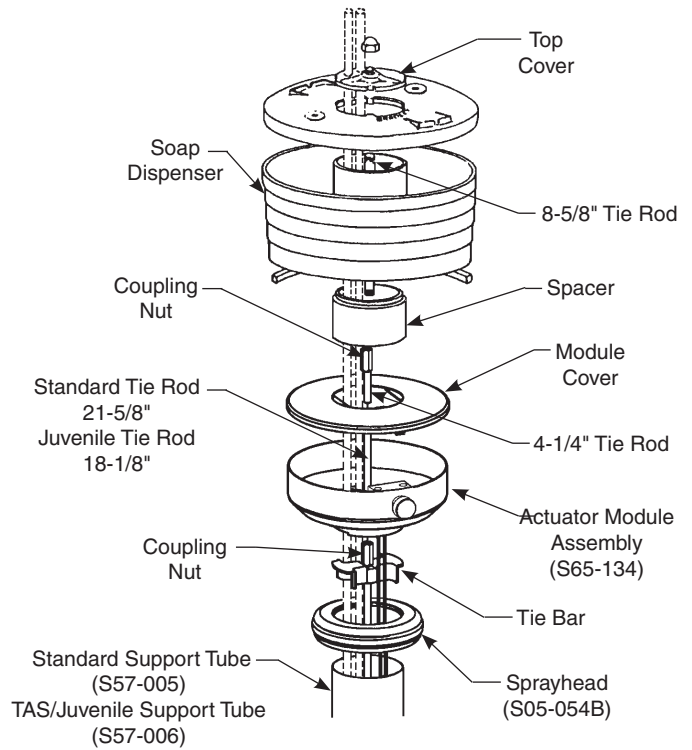

# 5b Air Metering Valve Assembly for B Drain and H Drain Units with Tie Pipe Option

**A** Install hemmed end (not sharp end) of support tube with gasket onto bowl.

**B** Place sprayhead with 3/8" tubing onto support tube. Run the tubing down through the support tube and connect to valve tube connector. Make sure the spray holes point away from the wall.

**C** Insert the 1-1/2" vent pipe (supplied by installer) down through the support tube and thread into vented trap.

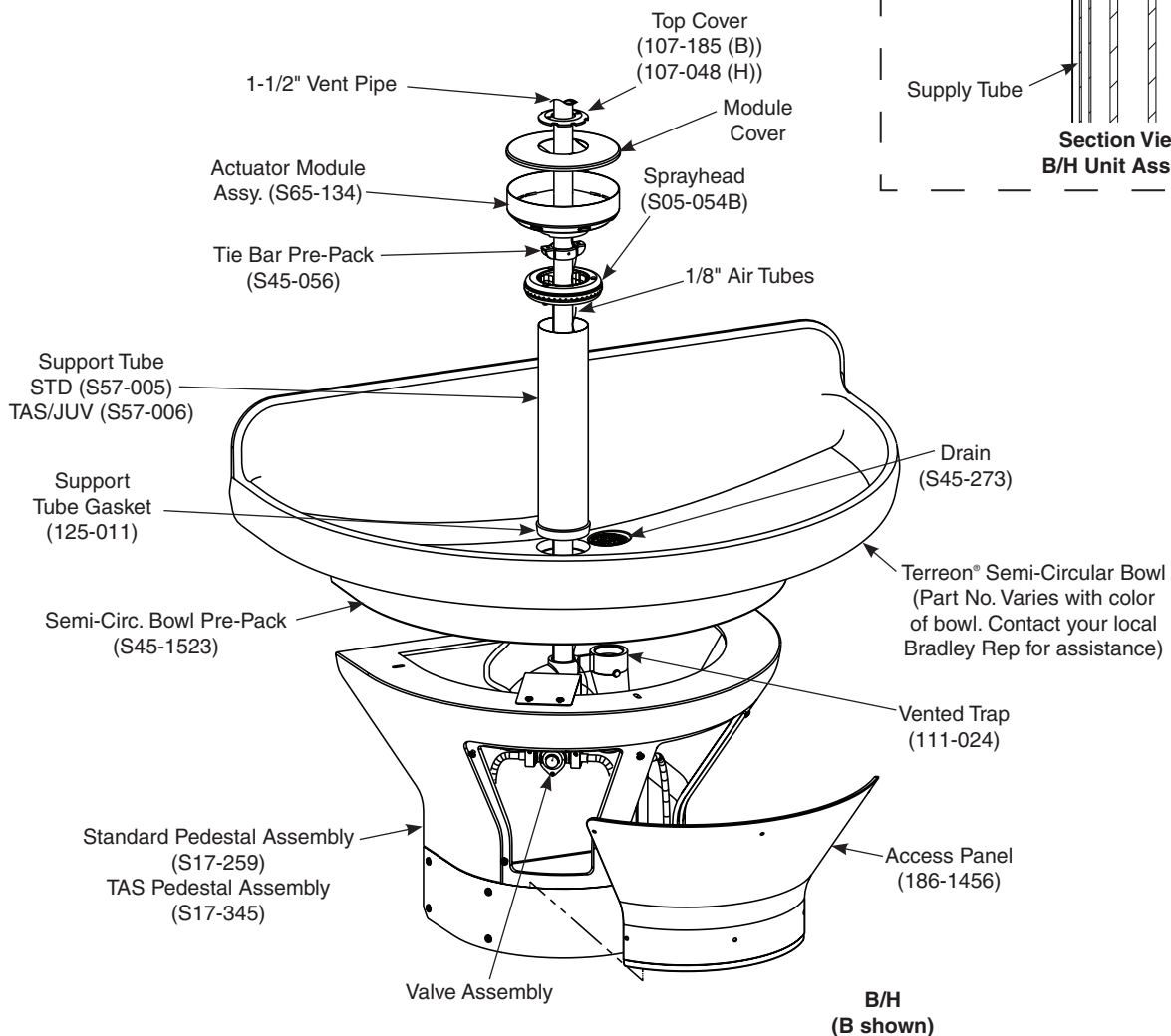
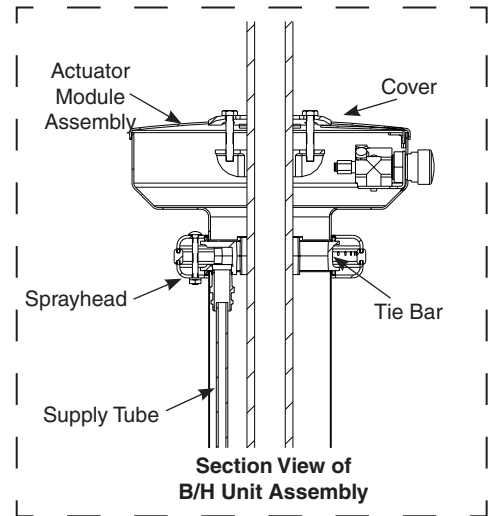

# 5b Air Metering Valve Assembly for B Drain and H Drain Units with Tie Pipe Option *continued...*

**D** Place the actuator module assembly on top of the sprayhead. Rotate until actuator module locks in with tie bar. Drop 1/8" diameter tube down to the valve assembly and connect to the air valve. Make sure air valve push button is facing away from wall.

 Skip to step F for units without soap.

**E** For units with soap option, slide the spacer and soap dispenser over the 1-1/2" pipe.

**F** Position the upper tie bar slightly below the module or soap dispenser and fasten securely to vent pipe with set screws provided. Secure top cover to tie bar with two cap screws provided.

**G** Connect supply stops onto stub-outs. Connect flexible hoses to supply stops.

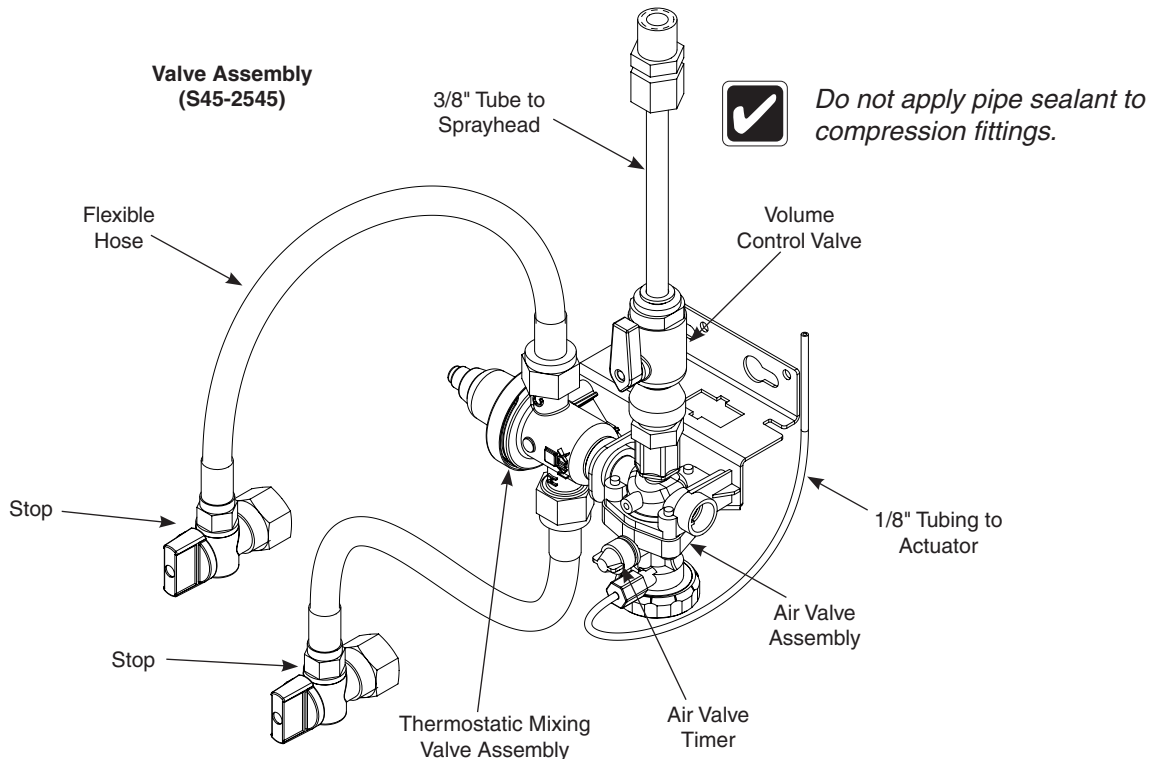
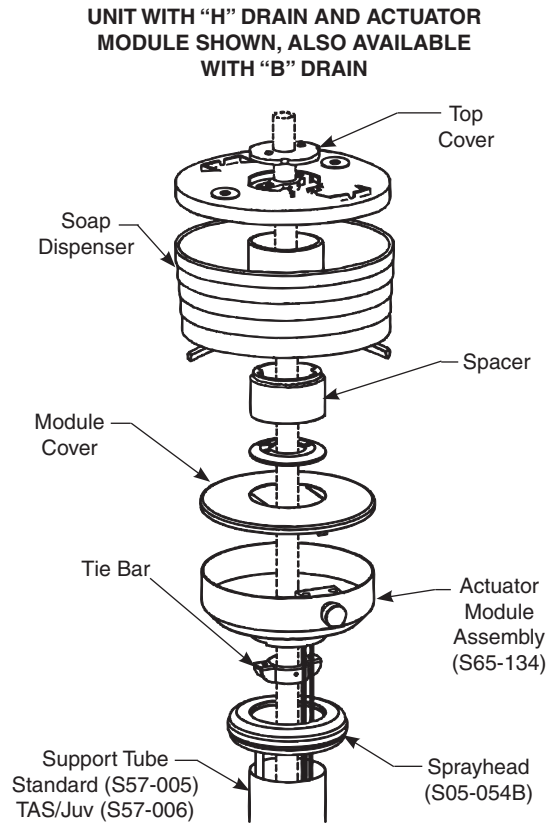

## 6 Valve and tubing connections



*Flush supply lines before making connections.  
Do not apply pipe sealant to compression fittings.*

**A** Attach hot and cold flexible supply lines to mixing valve assembly, two places. Make sure the hot supply is connected to the hot inlet on the valve (marked with the letter "H") and the cold supply is connected to the cold inlet on the valve (marked with the letter "C").

**B** Hang valve assembly on pedestal valve bracket.

**C** Use wire tie to secure valving to valve bracket.

**D** Turn supplies on. Open stop valves completely. Open volume control valve completely and check piping installation for leaks.

**E** Push actuator button until air is purged from the lines.

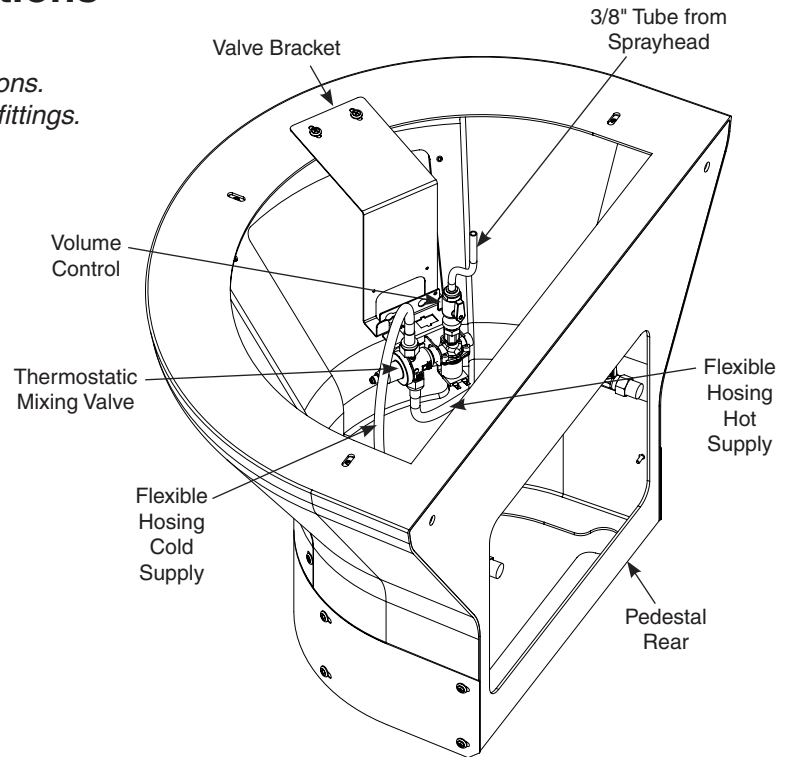

## 7 Adjust the Temperature



*This valve is NOT factory preset. Upon installation, the temperature of this valve must be checked and adjusted to ensure delivery of a safe water temperature. Water in excess of 110°F (43°C) may cause scalding.*

**A** Loosen Cap Screw about 1/4" (4-6 turns) and lift up cover (do not remove).

**B** Using cover, turn cartridge gently until desired water temperature is reached. Do not turn past stops as this may damage unit. Push cover down and tighten screw.

**C** Clean sprayhead if necessary. Adjust the volume control to control the flow of water.

**D** Attach pedestal access panel and kick plate with hardware provided.

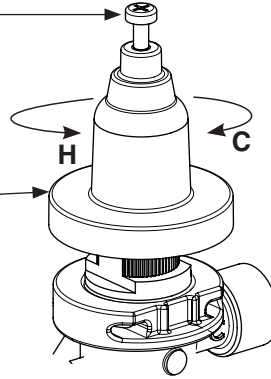

## Cleaning and maintenance instructions for Terreon®

**Material Description:** Terreon® is an NAHB Certified densified solid surface material composed of polyester resin and is resistant to chemicals, stains, burns and impact. Surface damage can be easily repaired with everyday cleansers or fine grit abrasives.

**Routine Cleaning:** Clean daily or as often as conditions require using a standard commercial or household cleaner such as Formula 409® or Windex®.

**Stubborn Stains:** Remove tough stains with Ajax®, Comet®, or Soft-Scrub® and a green Scotch-Brite® pad or lightly sand in a circular motion with 240 grit wet/dry sandpaper. The finish can be renewed with a maroon Scotch-Brite pad.

## Special Situations for Material

**Scratches:** Remove scratches with a green Scotch-Brite® pad. The finish can then be renewed with a maroon Scotch-Brite® pad.

**Hard Water Deposits:** Remove hard water deposits with a mild solution of vinegar and water. Always rinse the unit thoroughly after cleaning.

**Restoring the surface:** Use Hope's® Solid Surface cleaner and polish to refresh and protect the Terreon Solid Surface material. Bradley recommends additional care and maintenance for the darker colored Terreon. For complete instructions on this additional maintenance see Bradley document #1505.

**NOTICE! Do not use strong acid or alkaline chemicals and cleansers to clean Terreon. If these chemicals come in contact with the Terreon surface, wipe them off immediately and rinse with soapy water. Avoid contact with harsh chemicals such as paint remover, bleach, acetone, etc. Avoid contact with hot pans and objects.**

**Repair Kits:** Terreon repair kits are available. Contact your Bradley representative or distributor for part numbers and pricing.



*Repair kits are made to order and have a shelf life of 30 days.*

**Brand Names:** Use of brand names is intended only to indicate a type of cleaner. This does not constitute an endorsement, nor does the omission of any brand name cleaner imply its inadequacy. Many products named are regional in distribution, and can be found in local supermarkets, department and hardware stores, or through your cleaning service. It is emphasized that all products should be used in strict accordance with package instructions.

## Cleaning/Maintenance Instructions for Gel-coated Fiberglass

**Material Description:** The Terreon Washfountains referenced in this installation manual use a gel-coated fiberglass pedestal.

**Routine Cleaning:** The gel-coated pedestal should be cleaned daily or as often as needed with a mild solution of detergent and water. Always use a soft cloth to avoid damage to the finish.

**Repair Kits:** There are no repair kits available for fiberglass materials. However, replacement parts are available, contact your Bradley representative for pricing and part numbers.

**NOTICE! Do not expose gel-coated fiberglass to solvents as they will damage the material and may create harmful fumes.**

**Brand Names:** Use of brand names is intended only to indicate a type of cleaner. This does not constitute an endorsement, nor does the omission of any brand name cleaner imply its inadequacy. Many products named are regional in distribution, and can be found in local supermarkets, department and hardware stores, or through your cleaning service. It is emphasized that all products should be used in strict accordance with package instructions.



## Cleaning and maintenance instructions for stainless steel

**Material Description:** Stainless steel is extremely durable, and maintenance is simple and inexpensive. Proper care, particularly under corrosive conditions, is essential. Always start with the simplest solution and work your way toward the more complicated.

**Routine cleaning:** Daily or as often as needed use a solution of warm water and soap, detergent, or ammonia. Apply the cleaning solution per the manufacturer's instructions and always use a soft cloth or sponge to avoid damaging the finish.

**Stubborn Stains:** To remove stains from stainless steel use a stainless steel cleaner and polish such as Ball® stainless steel cleaner or a soft abrasive. Always follow the manufacturer's instructions and apply in the same direction as the polish lines.

**NOTICE! Never use ordinary steel wool or steel brushes on stainless steel. Always use stainless steel wool or stainless steel brushes.**

### Special Situations for Material

**Fingerprints and Smears:** To remove fingerprints or smears use a high quality stainless steel cleaner and polish in accordance with the manufacturer's instructions. Many of these products leave a protective coating that helps prevent future smears and fingerprints.

**Grease and Oil :** To remove grease and oil use a quality commercial detergent or caustic cleaner. Apply in accordance to the manufacturer's instructions and in the direction of the polish lines.

**Precautions:** Avoid prolonged contact with chlorides (bleaches, salts), bromides (sanitizing agents), thiocyanates (pesticides, photography chemicals, and some foods), and iodides on stainless steel equipment, especially if acid conditions exist.

**NOTICE! Do not permit salty solutions to evaporate and dry on stainless steel.**

The appearance of rust streaks on stainless steel leads to the belief that the stainless steel is rusting. Look for the actual source of the rust in some iron or steel particles which may be touching, but not actually a part of the stainless steel structure.

**NOTICE! Strongly acidic or caustic cleaners may attack the steel, causing a reddish film to appear. The use of these cleaners should be avoided.**

**Brand Names:** Use of brand names is intended only to indicate a type of cleaner. This does not constitute an endorsement, nor does the omission of any brand name cleaner imply its inadequacy. Many products named are regional in distribution, and can be found in local supermarkets, department and hardware stores, or through your cleaning service. It is emphasized that all products should be used in strict accordance with package instructions.

## Soap Valve — Liquid — S09-007S

### Parts List

Item	Part No.	Description	Attaching Parts S09-007S	
			Qty	
1	118-025	Valve Body	1	
2	110-007	Packing Nut	1	
3	135-001L	Spring	1	
4	125-001BU	Washer	1	
5	119-028	Plunger	1	
*	161-014	Nut	1	
*	124-001D	Washer	2	
*	142-002AH	Washer - Stainless Steel	1	

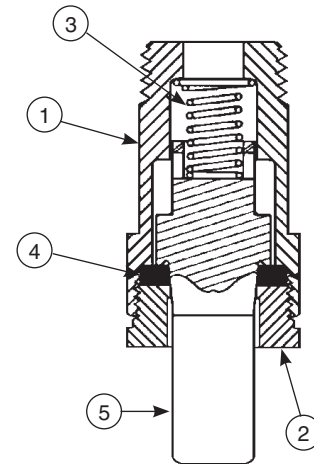

\* Not Illustrated

This valve delivers a measured amount of soap with each upward stroke. The soap dispenser has been standard on washfountains since 1983 and is not well-suited for very thick lotion soaps.

**NOTICE!** Lotion soap will clog liquid soap valves. Use only lotion soap valves with lotion soap.

## Soap Valve — Lotion — S09-057S

### Parts List

Item	Part No.	Description	Valve Assembly S09-057	Attaching Parts S09-057S
			Qty	Qty
1	124-001D	Washer	—	1
2	110-057	Nut	—	1
3	125-001AN	Stopper	—	1
4	159-114	Reinforcing Plate	—	1
5	124-001AT	Washer	—	1
6	160-176	Screw	—	1
7	S09-040	Valve	1	1
8	S53-045	Adaptor	1	1

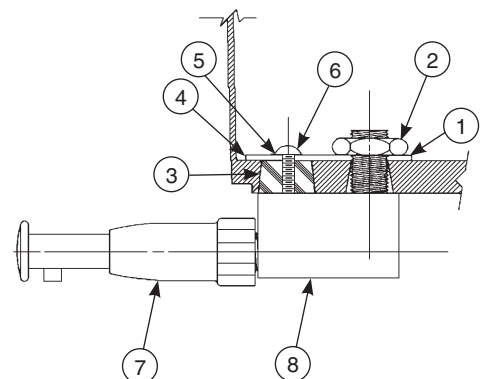

## Soap Valve — Powdered — S09-010A

### Parts List

Item	Part No.	Qty	Description
1	160-069	1	Screw, 1/4-20 RD
2	142-002X	1	Washer, 1/4 Split-Lock
3	S62-002	1	Agitator / Slide Assy.
4	192-004	1	Lever - Powdered Soap

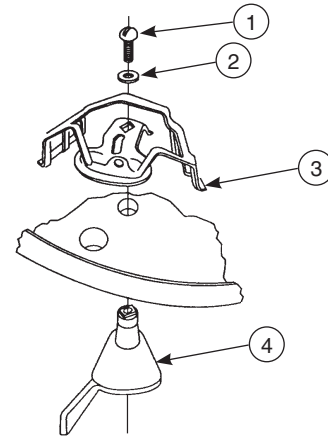

Reducer plugs are available for use with fine granulated soap to reduce the flow.



Valves can be changed from powdered to liquid by plugging the innermost, or “bearing” hole with rubber plug, part number 125-001AK. To change from liquid to powdered, the plug must be removed. If none is present, it will be necessary to drill out the bearing hole with a 1/2" or 5/8" drill. The plastic container configuration forms a natural template for locating the bearing hole.

## Soap Maintenance Tips

### Soap Recommendations

Quality soap dispensers require good quality soap and periodic maintenance to properly operate. Bradley soap dispensers will provide dependable, consistent operation over the long term when soap with reasonable viscosity and pH levels are used and when a minimal amount of periodic maintenance is performed on the valves.

Soap thickness is determined by a measurement called viscosity. Soap viscosity should be between 100 cps (centerpoise) and 2500 cps for all Bradley soap dispensers. Thinner soaps are perceived by the users as being “watered down” so users tend to take more than they need, resulting in waste. **Thick soaps flow slower and inhibit the “flushing” action of the valves, which allows the soap to congeal in the valve and cause clogs.**

The pH (acid) level of the soap should be in the range of 6.5 to 8.5. More acidic soaps (pH levels lower than 6.5) will corrode metal parts (even stainless steel!!) and degrade rubber and plastic components. They will also cause skin irritation. **Most inexpensive soaps (typically the pink lotion type) fall into this acidic category and will eventually cause valve failure and metal corrosion.** Base soaps (pH levels higher than 8.5) will cause swelling or degradation of rubber and plastic parts and skin irritation.

Generally, any quality soap meeting the viscosity and pH guidelines above will work well with Bradley soap dispensers. PCMX or Isopropanol based antibacterial soaps (within viscosity and pH limits) will also work with Bradley dispensers. Soaps satisfying these basic guidelines will provide consistent flow and reduce clogs.

Most soap dispenser problems are caused by soap that is too thick or corrosive, or by a lack of maintenance. Many soaps come in concentrate form which must be diluted with water. Often, the soap is improperly diluted or used straight out of the bottle, which causes clogging and valve failure. If proper soap is being used, valves that have never been cleaned are usually the source of dispensing problems. Bradley has entered into an agreement with Champion Brand Products to provide additional customer service for purchasers of our dispensers regarding soap issues. They are very helpful and can get to the bottom of almost any soap dispenser related problem. They also sell an excellent “Bradley approved” soap. Please see **Soap Instruction Sheet 215-1286** for details about soap valve cleaning or how to contact Champion. With proper maintenance and soap, Bradley dispensers will provide long term, trouble free operation.

### Soap Dispenser Maintenance Instructions

Bradley soap dispensers will provide dependable, consistent operation over the long term when the proper soap is used and when a minimal amount of periodic maintenance is performed on the valves. Valves must be maintained (cleaned) to function properly.

To ensure proper operation of your soap dispenser, follow these instructions:

- Once per month, unscrew valve from reservoir and soak it for 30 minutes in hot water.
- Push valve at least 20 times while it is soaking.
- Flush soap reservoir with hot water while valve is soaking.

In cases of extreme clogging, the valve should be disassembled and the parts should be soaked in hot water or cleaning solution to restore proper functioning. Soap dispensers that will not be used for extended periods of time (schools during summer break, etc.) should be drained, cleaned and left empty until put back into service. Soap left on the outside of dispensers can cause discoloration and corrosion of the reservoir (even on stainless steel units). All soap should be wiped or scrubbed off daily, then the outside of the dispenser should be rinsed with clear water and dried with a soft cloth.

## Sprayheads — Standard w/Neoprene Spray Ring Grommet



Repair kit does not include sprayhead grommet. Order as a separate item.

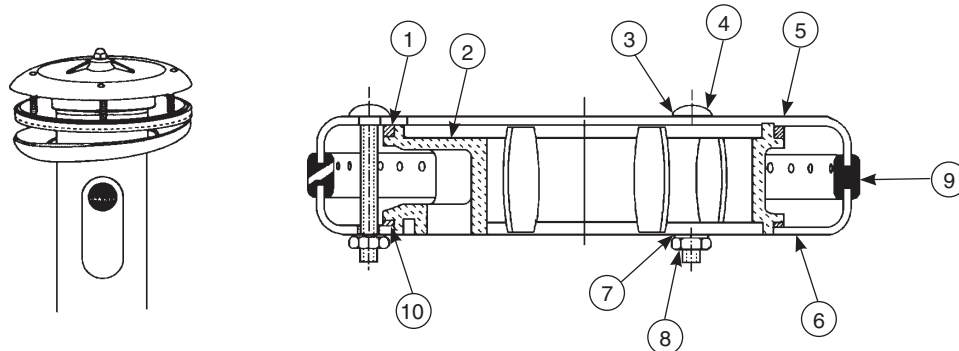

### Parts List

Item	Part No.	Description	Sprayhead Assembly S05-054B	Repair Kit S45-051
			Qty	
1	125-001DE	Neoprene Washer - Top	1	1
2	139-031	Sprayhead Manifold	1	—
3	124-001AL	Washer	3	4
4	160-211	Carriage Bolt	3	4
5	115-061	Sprayhead - Top	1	—
6	116-008	Sprayhead - Bottom	1	—
7	124-001AT	Washer	3	4
8	161-025	Nut	3	4
9	124-020D	Sprayhead Grommet - Semi-Circle	1	—
10	125-001DF	Neoprene Washer - Bottom	1	1

### Sprayhead Service Suggestions

Problem	Possible Cause	Solution
Water splashes over the rim of the bowl.	Foreign matter has reduced the size of the sprayhead slots, causing greater pressure at the open slots.	Clean the sprayhead: <ol style="list-style-type: none"> <li>1. Disassemble the sprayhead and dislodge any dirt, lime build-up and foreign debris with a wire brush.</li> <li>2. Sprayheads with rubber grommet spray rings may be cleaned by rubbing a coin over the grommet.</li> <li>3. Throttle down the volume control (water spray should strike the bowl without splashing outside of the bowl).</li> </ol>
Water flow diminishes from the sprayhead.	Strainer portion of the stop-strainer-check valve is plugged.	Remove and clean the strainer screen from the stop-strainer-check valve.



The sprayhead shown above includes a perforated neoprene spray ring grommet that is self-cleaning. The water pressure flexes the spray holes which slows accumulation of foreign matter and tends to “break loose” any such deposits that may have accumulated.

## Actuator Module Components

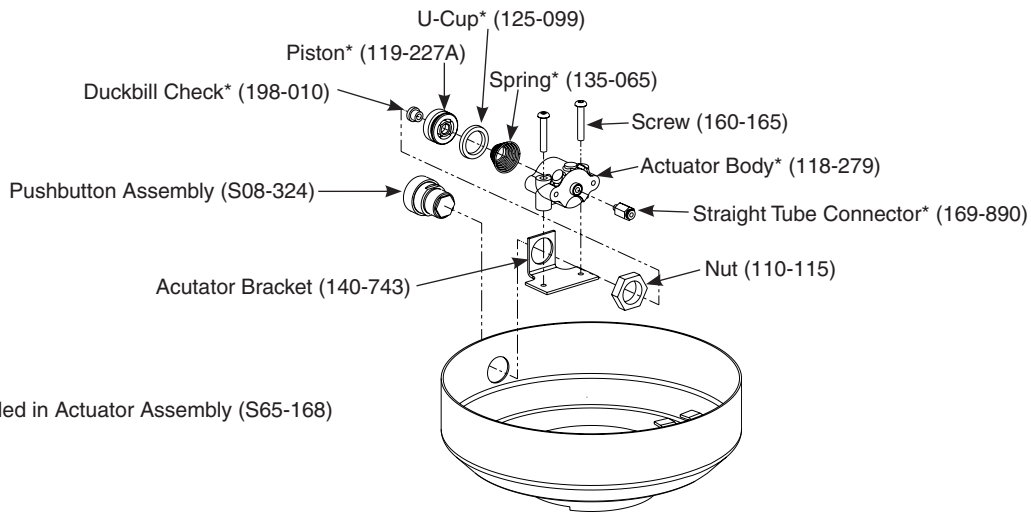

## Metering Air Valve Maintenance

### Adjust Air Valve Meter Time



The air valve timer is located next to the tube connector on the air valve body. The timer is capped with a filter to prevent build-up on the timer. The air valve timing can be adjusted from 5 to 60 seconds.

- A** Remove filter cap and use a screwdriver to tighten or loosen the timer. Turning the timer clockwise increases the time; turning the timer counterclockwise decreases the time.
- B** Continue to adjust until the timer is set at desired length.
- C** Replace filter cap over the timer.

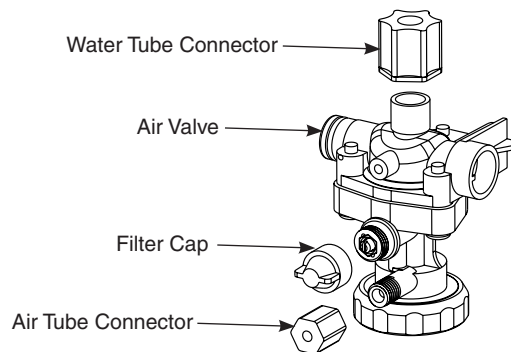

### Tube Connection Leaks

- A** Push in the white manual release button while pulling the tube out to disconnect the tube at the connector. No tools are needed.
- B** To correct a leak, press tubing firmly into the connector and make sure it is seated.
- C** If leak persists, remove tubing from the fitting and trim the tubing end square with a razor-sharp knife. If leak continues, replace the fitting or contact your Bradley representative for assistance.

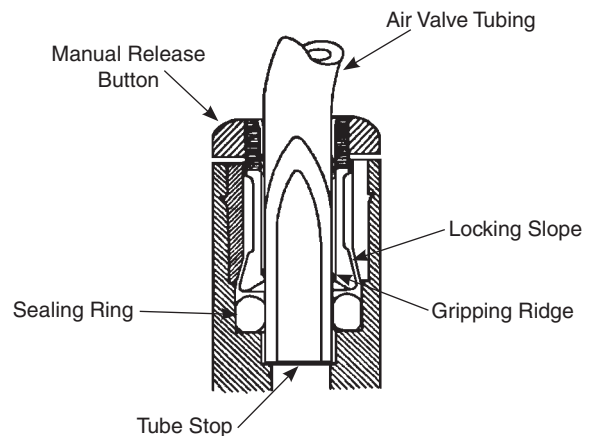

## Troubleshooting – Metering Air Valve



Turn off water supplies to the unit before troubleshooting.

Item	Qty.	Description
1	1	Diaphragm
2	1	Armature
3	1	Spring
4	1	AST 4 Valve Upper Body
5	1	Spring
6	1	Magnet/Diaphragm Assembly
7	1	AST 4 Valve Cover
8	1	AST 4 Valve Clamp Nut
9	1	AST 4 Valve Timer Assembly
10	2	O-Ring
11	1	AST 4 Valve Timer Cover
12	3	Screw, #8 x 7/8"
13	1	Compression Nut, 1/8" Tube
14	1	Compression Nut, 1/4" Tube
15	1	O-Ring

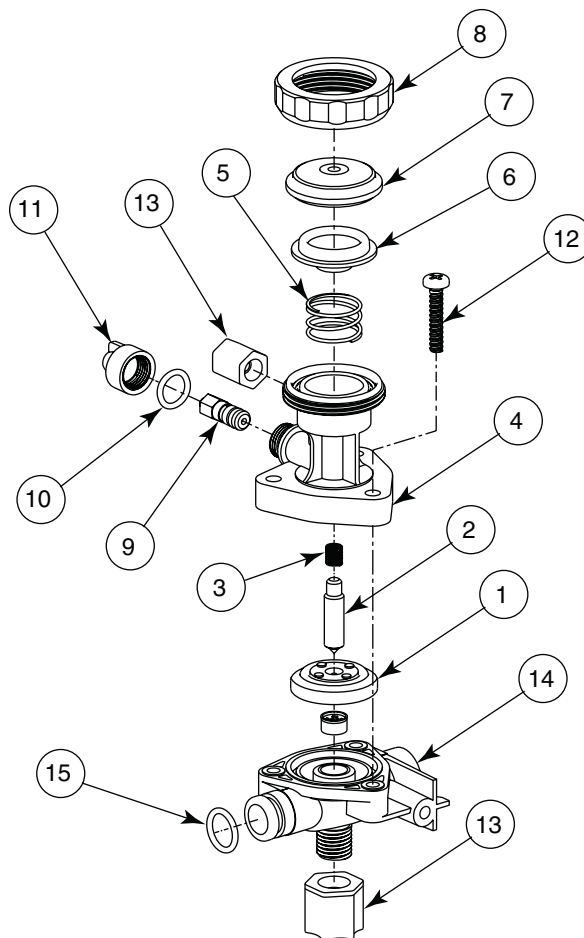

Problem	Cause	Solution
Valve will not shut off.	Timing mechanism is clogged.	Clean and inspect timing mechanism: 1. If compressed air is available, blow water and debris from timer cover of timing mechanism. 2. Turn adjusting screw out all the way. Clean and inspect screw and valve body. 3. Turn adjusting screw in to desired cycle time.
Valve will not turn on.	Water is not being supplied to unit.	Open all stops on mixing valve.
	Water pressure is over 80 PSI.	Install a pressure reducing valve.
	Failed diaphragm/magnet assembly.	Unscrew the valve clamp nut on valve. Remove valve cover. Gently press the diaphragm. The valve should activate. If not, replace the diaphragm/magnet assembly.
Timing can not be adjusted for more than 5 seconds.	There is an air leak.	Check the valve assembly: 1. Check all tubing and fittings for proper assembly. 2. Tighten cap and nut on 1/8" tubing.
Pushbutton does not work properly.	Air volume may not be sufficient to operate valve.	Check for leaks and lubricate U-cup: 1. Check all fittings for air leaks. 2. Disassemble pushbutton and lubricate U-cup seal (see pushbutton assembly diagram).
Water is dripping from the streamformers.	Debris has accumulated on valve seat or orifices.	Clean and inspect valve seat: 1. Remove screws and disassemble metering valve. 2. Clean valve seat and inspect for deep gouges or scratches. Replace valve body if necessary. 3. Remove any debris clogging off-center hole in rubber diaphragm.

# Thermostatic Mixing Valve Troubleshooting

Before attempting to troubleshoot the valve or disassemble the components, check for the following conditions:

- If stop valves are used, make sure that they are fully open.
- Make sure that the hot and cold inlet pipes are connected properly, and that there are no cross-connections or leaking stop valves.
- Check the hot water heater output to make sure that it is at least 10° F above the set temperature.



Be sure to close the appropriate shut-off valves prior to disassembly of the valve and reopen the valves after inspection and repair is complete.

Problem	Cause	Solution
External leaks.	Damaged cartridge or O-rings.	Replace cartridge with part number 269-1927
Improper water temperature or temperature fluctuation.	Hot water supply is not 10° above desired set point.	Increase hot water supply temperature
	Valve temperature is not properly set.	Adjust the temperature as shown on page 15, step 7.
Limited water flow.	Dirt and debris have built up in the valve or strainer.	<ol style="list-style-type: none"> <li>1. Check to make sure both hot and cold supplies are connected to the Navigator mixing valve and that they have water flow.</li> <li>2. Remove cover and U-clip. Remove the cartridge and clean the strainer. It is not required to grease cartridge, however if desired, use silicone grease only. Do not use grease on check valves.</li> </ol>

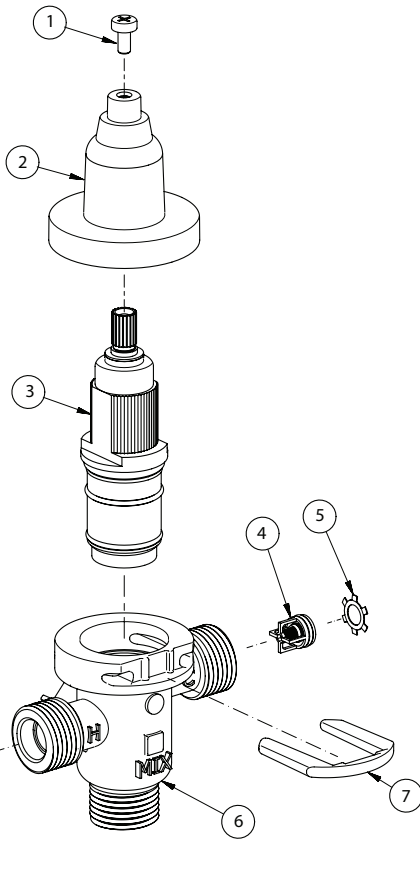

## Parts List

Item	Part No.	Description	Quantity
			S59-4000
1	160-463	Cap Screw	1
2	107-582	Cover	1
3	269-1927	Thermostatic Cartridge	1
4	198-014	Check Valve*	2
5	132-051	Retaining Ring*	2
6	118-319	Valve Body	1
7	146-079	U-Clip	1

\* Included with Prepack S65-326

**Tempered Line Adapter Option**  
**Part no. S39-804**  
 (replaces S59-4000 if tempered line is used)

Strainer (173-028)