



*O r i g i n s   S e r i e s*

# Use and Care Guide

**Wine Captain® Models:  
1115WC, 1175WC**



**1115WC**



**1175WC**

**1 Introduction**

Congratulations on your purchase of a U-Line refrigeration product. A pioneer in the field for more than 40 years, U-Line Corporation is the world's number one manufacturer of built-in, under-counter, specialty refrigeration and ice making products. U-Line dedicates 100% of its research and development to these products. The result: U-Line technology consistently leads the market with innovation, design, depth of product line and performance.

U-Line products are making life more convenient in homes, businesses, and hotels around the world. U-Line supports its products with a strong dealer network, and its commitment to quality even extends to environmentally safe packaging.

**IMPORTANT**

**READ all of the instructions in this guide completely before operating the unit for the first time.**

For future reference, keep this guide in a safe, accessible location. If you need additional information or assistance, please contact U-Line Corporation directly. Contact information appears on the rear cover of this guide.

If you have a problem with the operation of this product, the SERVICE section of this guide will assist you in quickly identifying common problems and provide information on possible causes and remedies. If your product needs service, contact U-Line directly.

**Warranty Registration**

Your U-Line Corporation Limited Warranty is located on the inside rear cover of this guide. To validate your warranty, the product and its original purchase date must be registered. A Warranty Registration Card has been included for this purpose in the package containing this manual. Complete and mail the Warranty Registration Card, or register your product online at [www.U-LineService.com](http://www.U-LineService.com) as soon as possible after purchase.

If your product registration is not on file and a request for warranty coverage is received, the date of sale to the U-Line Selling Dealer or Distributor will be established as the first date of warranty coverage for your product.

**Please Record Your Model Information**

When you request additional information or service, you will be asked for your products model and serial numbers. You can find this information on the serial plate located on the upper right or rear wall in the interior of your unit. This information also appears on the warranty registration card.



**Figure 1**

Please record the model number (**Figure 1, 1**), serial number (**Figure 1, 2**), date of purchase, and dealer contact information for your U-Line product below:

**Model Number:**

\_\_\_\_\_

**Dealer Name:**

\_\_\_\_\_

**Serial Number:**

\_\_\_\_\_

**Dealer Address:**

\_\_\_\_\_

**Purchase Date:**

\_\_\_\_\_

**Dealer Telephone:**

\_\_\_\_\_

**2 Table of Contents**

---

Introduction .....2  
    Warranty Registration .....2  
    Please Record Your Model Information .....2  
Table of Contents .....3  
Safety Precautions .....5  
    Safety Alert Definitions .....5  
    General Precautions .....5  
Product Features .....6  
    Origins Wine Captain® Models 1115WC, 1175WC .....6  
Operation .....7  
    Initial Startup .....7  
    Interior Lighting .....7  
    Electronic Control Panel .....8  
    Normal Operating Sounds .....9  
    Wine Stocking Recommendations .....9  
    Storage, Vacation, Moving .....10  
    Product Disposal .....10  
Wine Guide .....10  
    Wine Recommendations .....10  
Cleaning and Maintenance .....13  
    General Cleaning .....13  
    Maintenance .....13  
Service .....21  
    Before Calling for Service .....21  
    If Service is Required .....21  
    Replacement Parts .....21  
    Troubleshooting Guide .....22  
    Electronic Control Quick Guide .....23  
U-Line Corporation Limited Warranty .....27

This page intentionally left blank

### 3 Safety Precautions

#### IMPORTANT

PLEASE READ all instructions completely before attempting to install, operate, or service your unit.

- Proper installation procedures must be followed if this unit is being initially installed, or is moved to a new location after being in service. An **INSTALLATION GUIDE** for your unit, providing complete installation information is available from U-Line Corporation directly, and must be consulted before any installation is begun. U-Line contact information appears on the rear cover of this guide.
- This unit requires connection to a grounded (three-prong), polarized receptacle that has been placed by a qualified electrician in accordance with applicable electrical codes.

### Safety Alert Definitions

Safety items throughout this guide are labeled with a Danger, Warning or Caution based on the risk type:

#### DANGER

*Danger means that failure to follow this safety statement will result in severe personal injury or death.*

#### WARNING

Warning means that failure to follow this safety statement could result in serious personal injury or death.

#### CAUTION

Caution means that failure to follow this safety statement may result in minor or moderate personal injury, property or equipment damage.

### General Precautions

Use this appliance for its intended purpose only and follow these general precautions along with those listed throughout this guide:

#### DANGER

**RISK OF CHILD ENTRAPMENT.** Before you throw away your old refrigerator or freezer, take off the doors and leave shelves in place so that children may not easily climb inside.

#### WARNING

**SHOCK HAZARD - Electrical Grounding Required.**

- Never attempt to repair or perform maintenance on the unit until the electricity has been disconnected.
- Never remove the round grounding prong from the plug and never use a two-prong grounding adapter.
- Altering, cutting of power cord, removal of power cord, removal of power plug, or direct wiring can cause serious injury, fire and/or loss of property and/or life and will void the warranty.
- Never use an extension cord to connect power to the unit.
- Always keep your working area dry.

#### WARNING

The Anti-Tip Kit must be installed on this unit before it is used. Serious personal injury could occur.

#### CAUTION

- Use care when moving and handling the unit. Use gloves to prevent personal injury from sharp edges.
- If your model requires defrosting, **DO NOT** use any type of heater to defrost. Using a heater to speed up defrosting can cause personal injury and damage to the inner lining.

#### IMPORTANT

- Do not lift unit by door handle.
- Never install or operate the unit behind closed doors. Be sure front grille is free of obstruction. Obstructing free air flow can cause the unit to malfunction and may void the warranty.
- Failure to clean the condenser every three months can cause the unit to malfunction. This could void the warranty.
- Allow unit temperature to stabilize for 24 hours before use.
- If your model requires defrosting, never use an ice pick or other sharp instrument to help speed up defrosting. These instruments can puncture the inner lining or damage cooling unit.
- Use only genuine U-Line replacement parts. Imitation parts can damage the unit, affect its operation or performance and may void the warranty.

## 4 Product Features

### Origins Wine Captain® Models 1115WC, 1175WC

The Origins Wine Captain Models feature specially designed canted wine racks that allow for the proper horizontal storage of wine. The corks remain moist, which keeps air from entering the bottles. Model 1115WC will accommodate up to 24 bottles (750 mL size) and Model 1175WC will accommodate up to 48 bottles (750 mL size).

#### The Right Temperature for Wine

Your Wine Captain has been designed to provide three temperature zones within the cabinet so the specific storage requirements of your finest wines can be satisfied.

- An electronic control panel with digital display allows you to display the interior temperature in each zone. The unit is shipped from the factory with a default temperature of 50°F. The controller only controls the temperature of the middle zone. This zone can be set from 45-54°F. The upper zone will be approximately 5-6°F warmer and the lower zone will be approximately 5-6°F cooler than the middle zone. The electronic control and digital display provide an attractive appearance, and its method of control provides precise temperatures for storage of multiple types of wine.
- An interior light will illuminate automatically as the door is opened, providing easy visual identification of the wine. However, you can easily select two other modes of operation:
  - a. The interior light can be illuminated continuously, for a four-hour period, while the door is closed, providing an attractive display of your wine collection.
  - b. A blackout/Sabbath mode (not Star K certified) allows you to darken both interior lights and the LED display, while maintaining complete temperature control in the unit.
- The door features tinted thermal glass that protects your wines from potentially harmful light rays while providing a very fashionable appearance.
- Wine racks have a maple front trim that adds a fashionable appearance to the Wine Captain. The wood facing may be stained with a WATER-based stain, or replaced in its entirety with other woods or manufactured products (such as Corian® or Sandstone).
- Six sliding 3/4 extendable chrome wine racks provide easy access to all wine bottles.
- All models feature a black vinyl clad steel cabinet that provides a rich textured look, and resists scratching, peeling and flaking. Black models are equipped with a field-reversible door frame with a top mount integrated handle that is easy to maintain.

- Stainless steel units feature a wrapped stainless steel door frame and handle.
- Wine Captain Models are not recommended for outdoor use.
- Wine Captain Models installed in either a free-standing or built-in configuration must be anchored to prevent tipping, using the originally provided anti-tip kit.

Features and specifications are subject to change without notice.

**5 Operation**

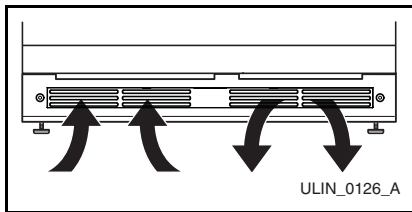

**Figure 2**

**IMPORTANT**

Proper air flow (Figure 2) is required for your unit to operate at its highest efficiency. A grille, located in the base of the unit, must not be blocked at any time, or your unit will not perform as expected.

**Initial Startup**

All U-Line units are shipped with controls that are preset. No initial adjustments are required.

**IMPORTANT**

U-Line recommends the unit be allowed to run overnight prior to loading with product.

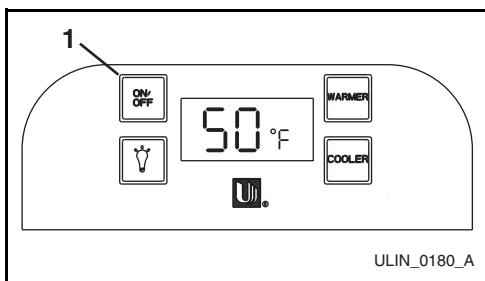
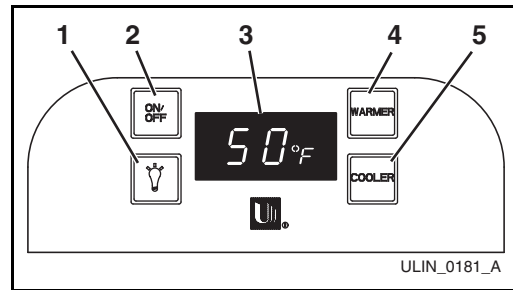

**Figure 3**

To turn the unit on or off, press and hold the ON/OFF button (Figure 3, 1) for approximately ten seconds and release. The display will show the unit set-point temperature when turned on and display OFF when the unit is off.

**Interior Lighting**

The interior of the cabinet can be illuminated whenever the door is opened or remained darkened for a 36-hour period (blackout/Sabbath mode [not Star K certified]).



**Figure 4**

The LIGHT button (Figure 4, 1) on the control panel is used to change the lighting functions.

To turn the lights and display off for a preset 36-hour interval (blackout/Sabbath mode [not Star K certified]):

1. Press and hold the LIGHT button (Figure 4, 1) for ten seconds and release (the °F symbol will flash briefly at the end of the ten second period).
2. The interior light and control display (Figure 4, 3) will go dark for the next 36 hours.

**NOTE:** Although the display will not be visible, the temperature controls in the unit remain active, and the interior temperature will be maintained.

3. To exit the blackout/Sabbath mode (not Star K certified) before the 36-hour period, repeat Step 1.

Another lighting mode is available. To illuminate the interior of the cabinet for a timed four-hour period:

1. Press and release the LIGHT button (Figure 4, 1) to switch from door-operated lighting control to the timed four hour lighting period (the °F symbol will flash briefly after the LIGHT button is pressed).
2. At the end of the four-hour period, the light will turn OFF and door-operated lighting control will resume.
3. To exit the timed lighting control before the end of the four-hour period, repeat Step 1.

## Electronic Control Panel

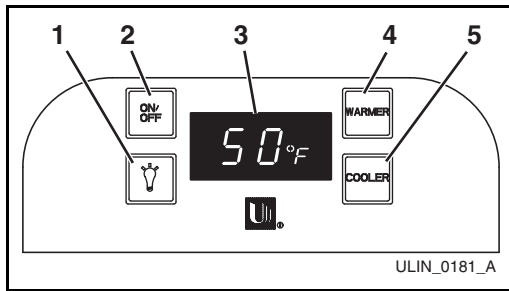

**Figure 5**

Your Wine Captain has been designed to provide three temperature zones within the cabinet so the specific storage requirements of your finest wines can be satisfied.

The electronic control with digital display (**Figure 5**) is configured to show a single temperature continuously. This set-point temperature is a base number used by the controller to maintain the temperature zones in your unit. The factory default set-point is 50°F. This set-point temperature is used as a gauge if further temperature adjustments are required.

A DISPLAY OFF mode is available through the control panel. This mode allows you to control whether the display (**Figure 5, 3**) will be on or off whenever the door is closed. The button sequence that follows will switch between both modes:

1. Press and hold the WARMER button (**Figure 5, 4**), and within five seconds press the ON/OFF button (**Figure 5, 2**) three times.
2. The display will be either visible or dark when the door is closed.
3. To return to the previous mode, repeat Step 1.

### Temperature Display Selection

U-Line products supplied for 110 VAC operation have temperatures displayed in a default Fahrenheit (°F) configuration (**Figure 5, 3**). Models supplied for 220 VAC operation have temperatures displayed in a default Celsius (°C) configuration.

The display can easily be adjusted for either type of temperature display. Press and hold the LIGHT button (**Figure 5, 1**) and within five seconds press the COOLER button (**Figure 5, 5**) three times to change the display as desired.

## Temperature Display

To display all zone temperatures:

1. Press and hold the WARMER button (**Figure 5, 4**) for approximately five seconds and release when the °F symbol in the display (**Figure 5, 3**) begins to flash.
2. The display (**Figure 5, 3**) will scroll through three individual readings at two second intervals per temperature.
  - The top horizontal bar in the symbol indicates the upper cabinet zone.
  - The middle horizontal bar in the symbol indicates the middle cabinet zone.
  - The bottom horizontal bar in the symbol indicates the lower cabinet zone.
3. The °F symbol in the display will indicate the individual zone temperature being displayed as they are the scrolling.
4. After the third scroll cycle is completed, the display will return to the set-point temperature.

## Checking Product Temperature

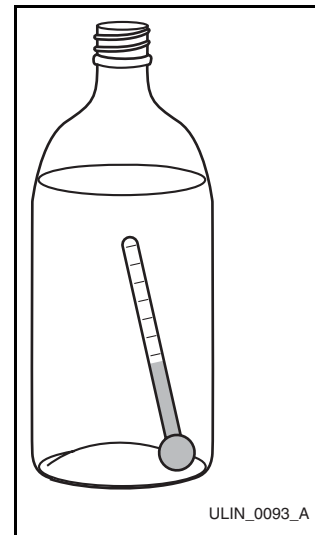

**Figure 6**

To check the actual product temperature in your unit, insert an accurate thermometer into a plastic (non-breakable) bottle that is partially filled with water. Tighten the bottle cap securely (**Figure 6**).

Place the bottle in the desired area for 24 hours. Refrain from opening the unit during the testing period. After 24 hours, check the temperature of the water. If required, adjust the temperature control in a small increment (See ADJUSTING TEMPERATURE).



Factors which affect the internal temperatures of the cabinet include:

- Temperature setting.
- Ambient temperature where installed.
- Number of times and length of time the door is opened and closed.
- Installation in direct sunlight or near a heat source.

### Adjusting Temperature

#### IMPORTANT

**Adjust the set-point temperature in single increments, and wait 24 hours for the temperature to stabilize before rechecking.**

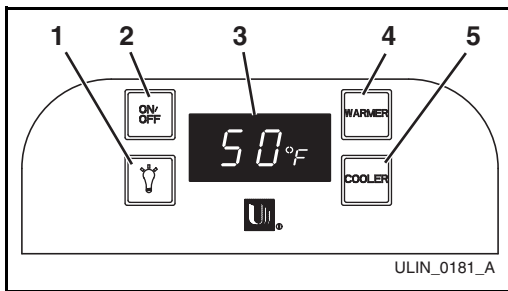

Figure 7

To adjust the set-point temperature:

1. Press and release either the WARMER (Figure 7, 4) or COOLER (Figure 7, 5) button to put the controller in the SET TEMPERATURE mode. The °F symbol will begin to flash.

**NOTE:** If no further action is taken, this mode will self cancel in five seconds, and the original set-point temperature will be displayed.

2. Within five seconds (while the °F symbol is flashing), press the WARMER or COOLER button as required to adjust the set-point temperature.
3. The change will be set five seconds after adjusting the temperature and the new set-point will be displayed (Figure 7, 3).

### Normal Operating Sounds

All models incorporate rigid foam insulated cabinets to provide high thermal efficiency and maximum sound reduction for its internal working components. In spite of this technology, your model may make sounds that are unfamiliar.

Normal operating sounds may be more noticeable because of the unit's environment. Hard surfaces such as cabinets, wood/vinyl/tiled floors and paneled walls have a tendency to reflect normal appliance operating noises.

Common refrigeration components, and a brief description of the normal operating sounds they make, are listed below. **NOTE:** Your product may not contain all of the components listed.

- Compressor: The compressor makes a hum or pulsing sound that may be heard when it operates.
- Evaporator: Refrigerant flowing through an evaporator may sound like boiling liquid.
- Condenser Fan: Air moving through a condenser may be heard.
- Automatic Defrost/Drain Pan: Water may be heard dripping or running into the drain pan when the unit is in the defrost cycle.

### Wine Stocking Recommendations

Specially designed wine racks allow for the proper horizontal storage of wine. The bottles are properly positioned so that the wine remains in contact with the cork to assure that the cork does not become dry.

Stock your unit as follows:

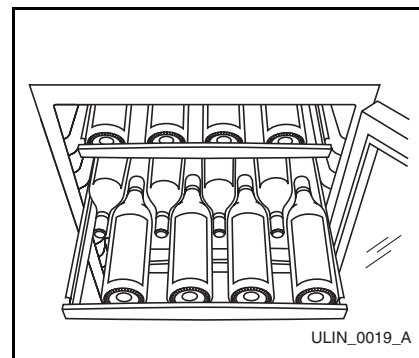

Figure 8

1. The wine racks should be stocked beginning with the lowest rack, at the back, and working forward. Stagger the bottles as shown (Figure 8).
2. Repeat Step 1 to stock the next higher rack, and continue until all racks are filled.

**NOTE: After stocking, allow unit to run 24 hours to stabilize product temperatures.**

## Storage, Vacation, Moving

If the unit will not be used for an extended period, or otherwise stored, follow these steps completely:

### **WARNING**

**Electrical Shock Hazard. Disconnect power before servicing. Before operating, replace all panels. Failure to do so may result in death or electrical shock.**

1. Remove all consumable contents from the unit.
2. Disconnect the power cord from its outlet, and leave it disconnected until the unit is returned to service.
3. Clean and dry the interior of the cabinet (See CLEANING AND MAINTENANCE: GENERAL CLEANING).
4. During periods of non-use, the cabinet must remain open to prevent the formation of mold and mildew. Open door a minimum of 2 in. (5 cm) to provide the necessary ventilation.

## Product Disposal

If the unit is being removed from service for disposal, check and obey all Federal, State and/or Local regulations regarding the disposal and recycling of refrigeration appliances, and follow these steps completely:

1. Remove all consumable contents from the unit.
2. Disconnect power to the unit and unplug the power cord from its outlet.

### **DANGER**

**RISK OF CHILD ENTRAPMENT. Before you throw away your old refrigerator or freezer, take off the doors and leave shelves in place so that children may not easily climb inside.**

3. Remove the cabinet door.

## 6 Wine Guide

### Wine Recommendations

To most, wine is a delicious mystery. We purchase it, uncork it, and savor its taste and beauty. But there is so much more to true wine appreciation. Many secrets are simply too good to keep bottled up. The U-Line Corporation is proud to present Spilling Wine Secrets online at [www.U-Line.com/resources/wine\\_secrets](http://www.U-Line.com/resources/wine_secrets). Take a moment to explore this section of our website to uncover wine myths, learn ideal storage conditions or ask our wine expert, Mr. Dave Barna, a specific question relating to wine. Mr. Barna will respond to your inquiry, and it may also be selected to appear on our Questions and Answers page.

### Wine Selections Suggestions

Selecting the right wine for the right occasion can sometimes be a seemingly awkward or difficult task for the beginning wine enthusiast. We would therefore like to present you with a few suggestions which may provide a little more confidence and enjoyment when choosing and serving your wines.

When selecting wines, keep an open mind and do not be afraid to be adventurous. Do not view the subject of wine so seriously it discourages you from learning and discovering for fear of embarrassment if something is incorrect. Wine is best viewed as a hobby and enjoyed.

When assembling your collection, try not to become obsessed with "Vintages." Although a chart can be a useful tool, generalizations about a specific year have led more than one collector to disappointment. In many instances an "Off Year" will provide a better value and more drinking enjoyment.

The primary guideline to the subject of wine is your own palate. Do not be afraid to make mistakes. Experiment, discover, but most of all, enjoy yourself and your new U-Line product.

### Suggestions for Matching Food and Wine

Although there are no hard fast rules for matching wine to food, observe some guidelines. Delicate dishes should be accompanied by lighter more delicate wines. Full-flavored foods should be matched with fuller-bodied wines.

As a general rule, one should aim to ascend in flavor and quality of wines served.

**Table 1**

Serve a:	Before a:
DRY wine	SWEET wine
WHITE wine	RED wine
YOUNG wine	OLD wine
LIGHT-BODIED wine	FULL-BODIED wine

Any step back in quality will be noticed. If a fine wine is tasted prior to a lesser wine, many of the fine wine's subtle qualities may be missed.

### Common Food and Wine Matches

**Table 2**

Foods	Wines
Fish, Shell Fish, Crab, Oysters	Dry White Wines, Light Sparkling or Extra Dry Champagne
Beef, Venison	Full-Bodied Red Wines
Pork, Veal, Lamb and Poultry	Light-Bodied Red Wines
Fruit	Sweet White and Sparkling Wines

## Guide to Common Styles of Wine

<b>Red Wines</b>		
Full-Bodied Dry	California French Italian	Zinfandel, Cabernet Rhone, Chateauf-neuf-du-Pape Barbaresco, Barolo
Medium-Bodied Dry	California French	Pinot Noir Bordeaux, Burgundy
Light-Bodied Dry	French Italian	Beaujolais Chianti, Bardolino
<b>White Wines</b>		
Full-Bodied Dry	California French	Chardonnay Montrachet, Meursault Puligny-Montrachet
Medium-Bodied Dry	California French	Sauvignon-Blanc Pouilly-Fuisse, Sancerre, Vouvray, Graves
Light-Bodied Dry	French	Chablis, Muscadet, Pouilly-Fume
Full-Bodied, Very Sweet	Germany Freny Hungary	Beerenauslese Sauternes Tokay
Medium-Bodied, Semi-Sweet	California Germany	Gewurtztraminer Liebfraumilch
Light-Bodied Off Dry	Germany	Rhine, Mosel, Riesling

## Common Tasting Terms

<b>Terminology</b>	<b>Description</b>
Acidity	A critical element of wine that is responsible for preserving the wines freshness. Excess acidity results in an overly tart and sour wine.
Balance	A desired trait where tannin, fruit and acidity are in total harmony. Wines with good balance tend to age gracefully.
Body	The weight and presence of wine in the mouth provided by the alcohol and tannin level. Full-bodied wines tend to have this strong concentration.
Bouquet	The blending of a wine's aroma within the bottle over a period of time, caused by volatile acidity.
Complex	A subjective term often used in tasting. A wine is said to be complex if it offers a variety of flavors and scents that continue to evolve as it develops.
Flabby	A wine that lacks structure, or is heavy to the taste, lacks acidity.
Full-Bodied	Wine high in alcohol and extract, generally speaking, fills the mouth, powerful.
Lean	Generally describes wines that are slim, lacking of generosity or thin.
Oaky	A desirable flavor imparted to wine if done in moderation. Most wines are aged in oak barrels one to three years, thereby receiving this toasty oak characteristic. However, if a weak wine is left in contact too long with an oak barrel it will tend to be overpowered with an oaky taste.
Tannin	Tannins are extracted from the grape skins and stems and are necessary for a well-balanced red wine. Tannins are easily identified in wine tasting as the drying sensation over the gums. Tannins generally fade as a wine ages.

## 7 Cleaning and Maintenance

### General Cleaning

#### Exterior Cleaning (As Required)

##### Black Models:

- Surfaces may be cleaned with a mild detergent and warm water solution. Do not use solvent-based or abrasive cleaners. Use a soft sponge and rinse with clean water. Wipe with a soft, clean towel to prevent water spotting.
- Clean any glass surfaces with a non-chlorine glass cleaner.

##### Stainless Models:

- Stainless door panels, handles and frames can discolor when exposed to chlorine gas, pool chemicals, salt water or cleaners with bleach.
- Keep your stainless unit looking new by cleaning with a good quality all-in-one stainless steel cleaner/polish on a monthly basis. For best results use Claire® Stainless Steel Polish and Cleaner, which can be purchased from U-Line Corporation (P/N 173348). Comparable products are acceptable. Frequent cleaning will remove surface contamination that could lead to rust. Some installations may require cleaning on a weekly basis.
- Do not clean with steel wool pads.**
- Do not use stainless steel cleaners/polishes on any glass surfaces.**
- Clean any glass surfaces with a non-chlorine glass cleaner.
- Do not use cleaners that are not specifically intended for stainless steel on stainless surfaces (this includes glass, tile and counter cleaners).**
- If any surface discoloring or rusting appears, clean it quickly with Bon-Ami® or Barkeepers Friend Cleanser® and a non-abrasive cloth. Always clean in the direction of the grain. Always finish this process with Claire Stainless Steel Polish and Cleaner or comparable product to prevent further problems.
- Using abrasive pads such as Scotchbrite™ will cause the graining in the stainless to become blurred.**
- Rust that is not cleaned up promptly can penetrate into the surface of the stainless steel and complete removal of the rust may not be possible.

#### Interior Cleaning (As Required)

- Disconnect power to the unit. Clean the interior and all removed components using a mild non-abrasive detergent and warm water solution applied with a soft sponge or non-abrasive cloth. Rinse the interior using a soft sponge and clean water.

- Do not use any solvent-based or abrasive cleaners. These types of cleaners may transmit taste to the interior products and damage or discolor the interior.**

### Maintenance

Proper maintenance of your U-Line product will ensure efficiency, top performance and long life. The maintenance intervals listed are based on normal conditions. You may want to shorten the intervals if you have pets or other special considerations.

### Defrosting

#### Automatic (Cycle) Defrost Models

Automatic defrost models do not produce frost in normal operating conditions. However, a frost pattern may be noticed on the interior walls if the unit is repeatedly opened in a high heat or high humidity location. If this frost pattern does not clear within 24 hours, your unit will require manual defrosting.

#### WARNING

**DO NOT use any type of electrical heating device, ice pick, knife or other sharp instrument to defrost; this could damage the inner lining or refrigeration system and void the warranty.**

#### IMPORTANT

**The drain pan was not designed to capture the water created when manually defrosting. To prevent water from overflowing the drain pan, place towels or other absorbent materials over the interior drain trough, under the evaporator (Figure 9, 1), before defrosting.**

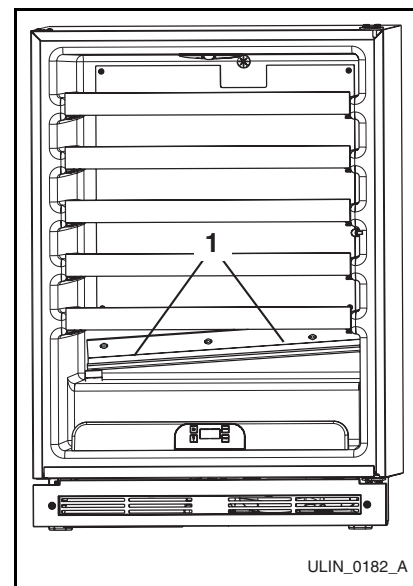

Figure 9

To defrost:

1. Turn unit off.
2. Remove all products from the interior and prop the door in an open position (2 in. (5 cm) minimum).
3. Allow the frost to completely melt naturally. Clean the interior and all removed components using a mild non-abrasive detergent and warm water solution applied with a soft sponge or non-abrasive cloth. **NOTE:** DO NOT use any solvent-based or abrasive cleaners. They will discolor or damage the interior.
4. Dampen a soft sponge or non-abrasive cloth in clean water and wipe down the cabinet interior and removed components to remove any detergent residue. Rinse the sponge or cloth in clean water and repeat as necessary until the cabinet and components are clean.
5. When the interior is dry, turn unit back on.

### Condenser Cleaning

#### Interval - Every Three Months

To maintain operational efficiency, keep the front grille free of dust and lint, and clean the condenser every three months. Depending on environmental conditions, more or less frequent cleaning may be necessary.

**⚠ WARNING**

**Disconnect electric power to the unit before cleaning the condenser.**

**⚠ WARNING**

**DO NOT touch the condenser fins. The condenser fins are SHARP and can be easily damaged.**

**IMPORTANT**

**DO NOT use any type of cleaner on the condenser unit.**

#### Model 1115WC

1. Disconnect power to the unit.

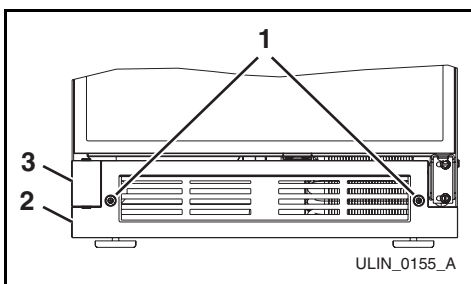
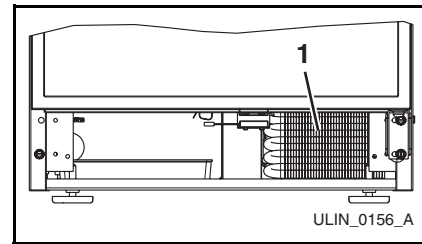

**Figure 10**

2. Loosen the two screws (**Figure 10, 1**) completely.

**NOTE:** Screws are held in the grille by o-ring retainers, and will not come free of the grille.

3. Remove grille (**Figure 10, 2**) and grille cap (**Figure 10, 3**) from unit.



**Figure 11**

4. Clean the condenser coil (**Figure 11, 1**) using a soft brush with a “combing” action or vacuum cleaner. Do not touch the condenser coil.

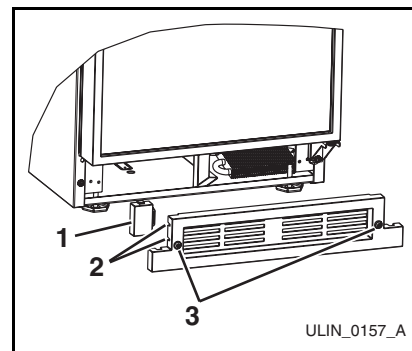

**Figure 12**

5. Make sure grille cap (**Figure 12, 1**) is behind grille in slots (**Figure 12, 2**) provided in grille before attaching grille to unit, and secure, but do not overtighten both grille screws (**Figure 12, 3**).

6. Reconnect power to the unit.

#### Model 1175WC

1. Disconnect power to unit.

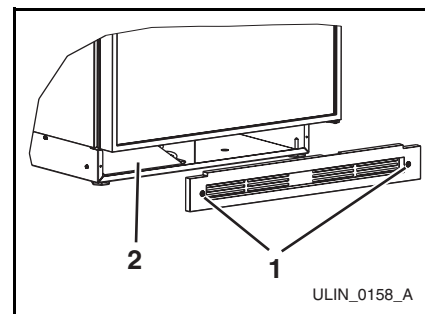

**Figure 13**

2. Loosen the two screws (**Figure 13, 1**) completely.

**NOTE:** Screws are held in the grille by o-ring retainers, and will not come free of the grille.

3. Remove grille from unit.

- Clean the condenser coil (**Figure 13, 2**) using a soft brush with a “combing” action or vacuum cleaner. Do not touch the condenser coil.

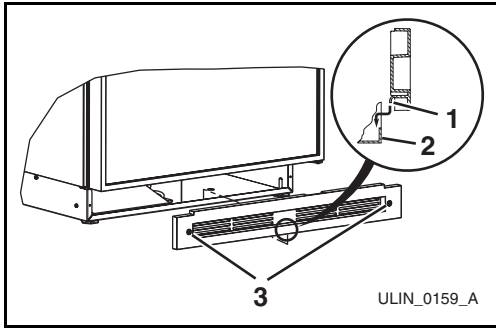

**Figure 14**

- Place the hook-hinge (**Figure 14, 1**) located on the rear bottom side of the grille onto the front lip (**Figure 14, 2**) of the unit base. Swing the grille up into position, and align the screw holes on the grille to the grille screw hole on the cabinet.
- Secure, but do not overtighten both grille screws (**Figure 14, 3**).
- Reconnect power to unit.

### Leveling

It is important that units equipped with adjustable feet are level, for proper door and ice maker (if equipped) operation.

To level units with adjustable feet:

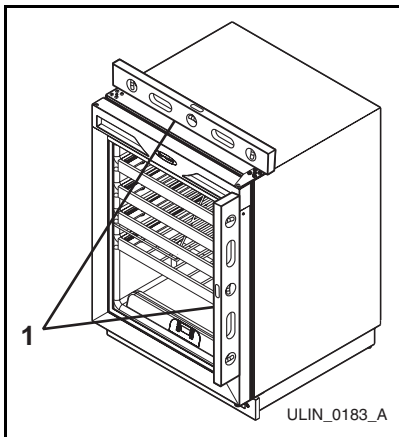

**Figure 15**

- Use a level to check the levelness of the unit from front to back and from side to side. Level should be placed along top edge and side edge as shown (**Figure 15**).

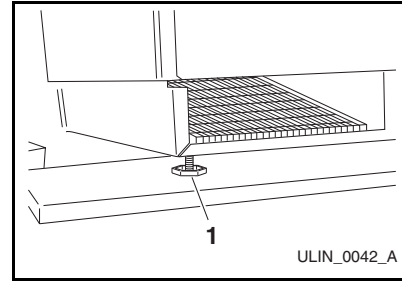

**Figure 16**

- If the unit is not level, adjust the feet on the corners of the unit as necessary (**Figure 16**).
- Check the levelness after each adjustment and repeat the previous steps until the unit is level.

### Door Alignment Check and Adjustment

#### IMPORTANT

Properly aligned, the door's gasket should be firmly in contact with the cabinet all the way around the door (no gaps). Carefully examine the door's gasket to assure that it is firmly in contact with the cabinet. Also make sure the door gasket is not pinched on the hinge side of the door.

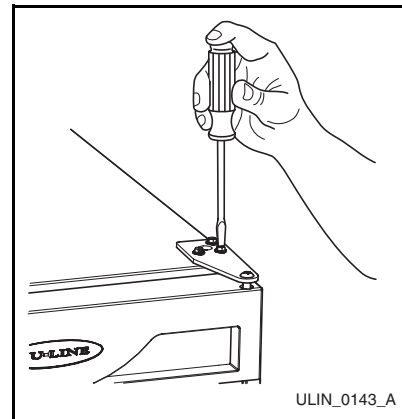

**Figure 17**

- Loosen (do not remove) top (**Figure 17**) and bottom hinge screws.
- Align door squarely with cabinet.
- Make sure gasket is firmly in contact with cabinet all the way around the door (no gaps).
- Tighten bottom hinge screws.
- Tighten top hinge screws.

## Door Reversal

Black model doors may be left- or right-hand opening. Stainless steel units are not field reversible.

### Model 1115WC

To reverse the door, perform the following:

1. Remove the grille and grille cap (two screws).

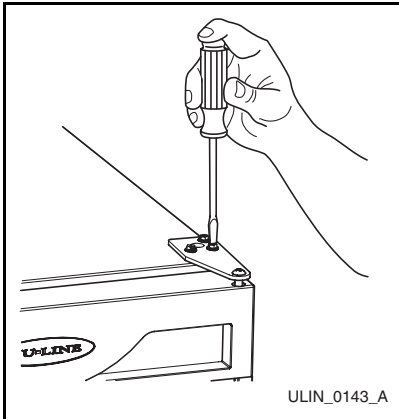

**Figure 18**

2. Remove top hinge from cabinet (three screws) (**Figure 18**). Hold door to keep it from falling.
3. Lift the door off the bottom hinge.

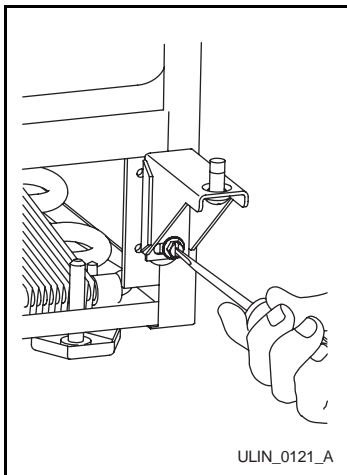

**Figure 19**

4. Remove bottom hinge from cabinet (two screws) (**Figure 19**).

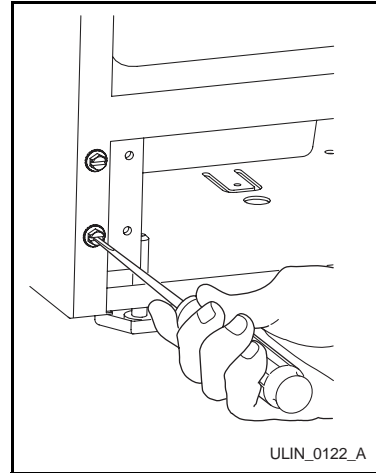

**Figure 20**

5. Remove screws on opposite side of cabinet (**Figure 20**). Note that there may be a nut behind one or both screws on either side.

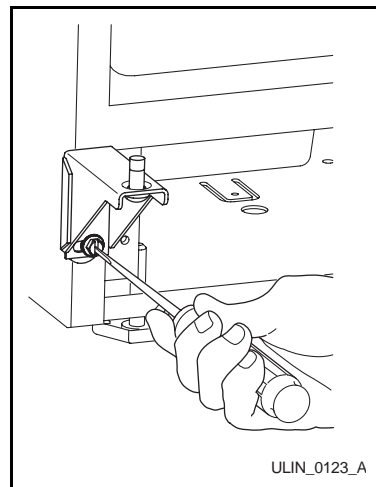

**Figure 21**

6. Install hinge on opposite side, bottom of cabinet (**Figure 21**). Replace nut on back side where installed. Align hinge outer edge with cabinet before tightening screws.

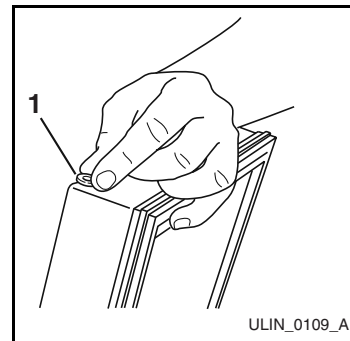

**Figure 22**



- Relocate plastic spacer/bushing (**Figure 22**) on bottom of door to opposite side, and place door on bottom hinge pin. Clean out bushing hole in door bottom with a screwdriver if necessary.

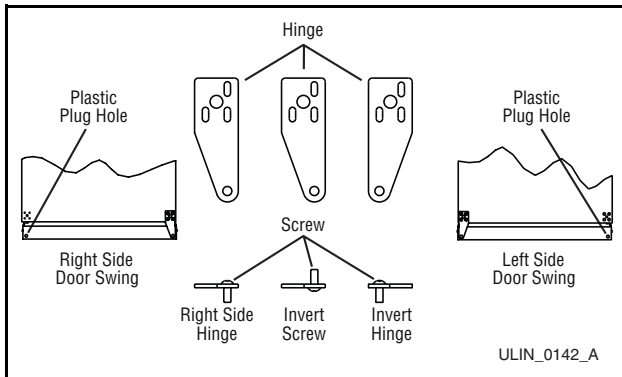

**Figure 23**

- Remove plastic hole plug (**Figure 23**) from door handle and relocate on opposite side.
- Remove pivot screw from top hinge, invert screw and reinstall pivot screw in top hinge. See **Figure 26**.

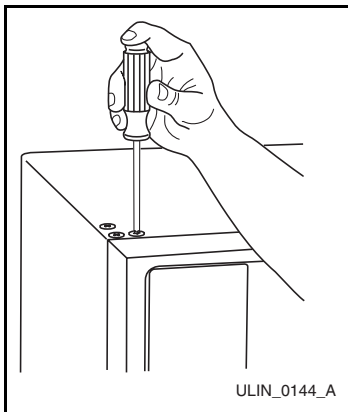

**Figure 24**

- Remove three plastic screw plugs (**Figure 24**) from hinge holes, top of cabinet, opposite side. Be careful not to scratch cabinet.
- Place door on lower hinge pin. Invert and install upper hinge on door.

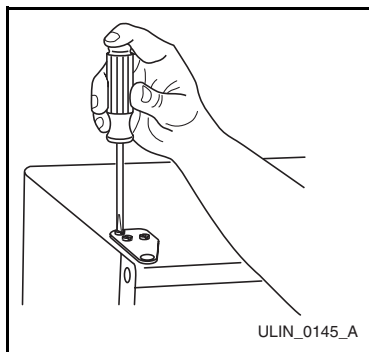

**Figure 25**

- Fasten upper hinge to unit (three screws) (**Figure 25**). Partially tighten screws.
- Adjust door to assure proper seal. Tighten upper and lower hinge screws securely.
- Replace three plastic plugs removed in Step 10 into holes on top of unit. Replace screws in holes in bottom of unit on opposite side.
- Replace the grille and grille cap. Be sure to place grille cap on opposite side of unit from where it was originally.

**Model 1175WC**

To reverse the door, perform the following:

- Remove the grille (two screws).

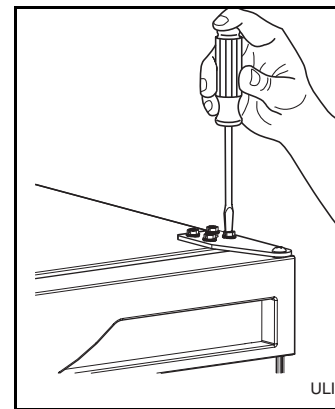

**Figure 26**

- Remove top hinge from cabinet (four screws) (**Figure 26**). Hold door to keep it from falling.
- Lift the door off the bottom hinge.

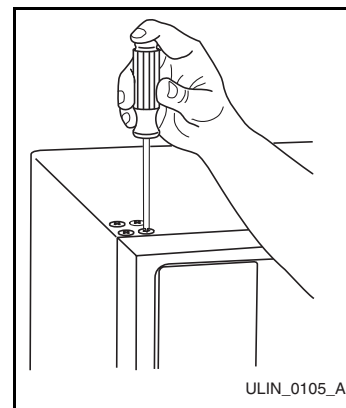

**Figure 27**

- Remove four plastic plugs (**Figure 27**) in hinge holes, top of cabinet, opposite side. Be careful not to scratch cabinet.

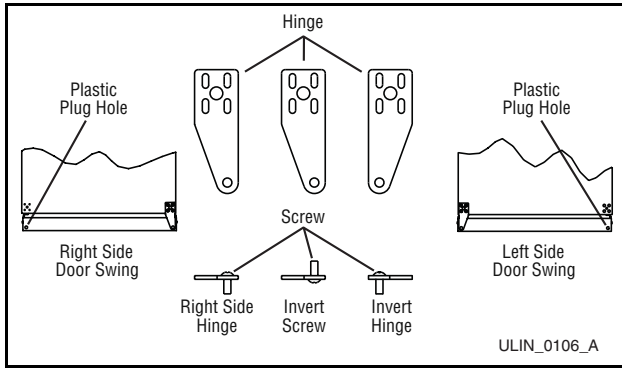

**Figure 28**

- Remove pivot screw from top hinge, invert screw and reinstall pivot screw in top hinge (**Figure 28**). Do not install hinge on cabinet at this time.

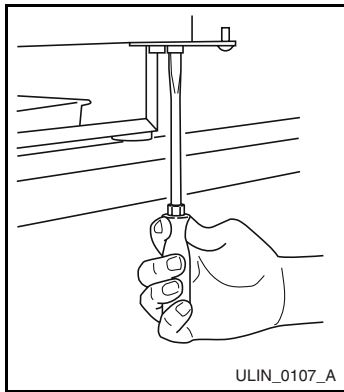

**Figure 29**

- Remove bottom hinge from cabinet (four screws) and screws on opposite side of cabinet (**Figure 29**).
- Remove pivot screw from bottom hinge, invert screw and reinstall pivot screw in hinge (**Figure 28**).

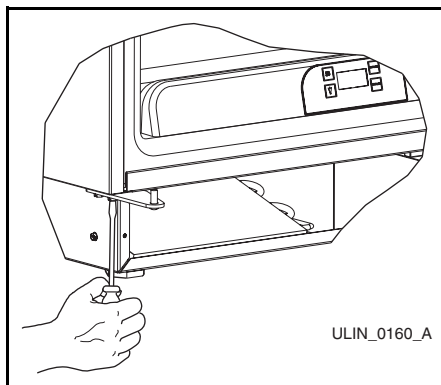

**Figure 30**

- Install bottom hinge on cabinet, opposite side, aligning flat edge of hinge with outer edge of unit (**Figure 30**). Partially tighten screws.

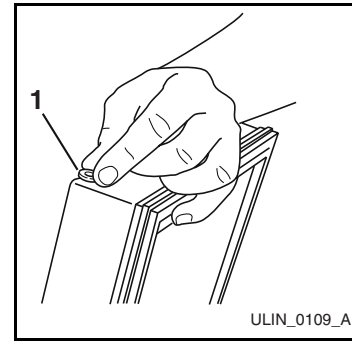

**Figure 31**

- Relocate plastic spacer/bushing (**Figure 31**) on bottom of door to the opposite side. Clean out bushing hole in door bottom if necessary.

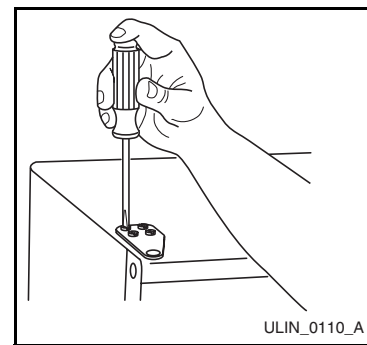
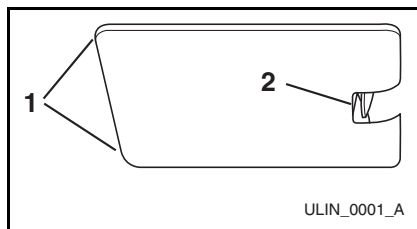

**Figure 32**

- Place door on lower hinge pin. Align flat edge of top hinge with outer edge of unit and fasten upper hinge to unit (four screws) (**Figure 32**). Partially tighten screws until door is aligned.
- Adjust door to assure proper seal. Tighten upper and lower hinge screws securely.
- Replace four plastic plugs removed in Step 4 into holes on top of unit. Replace screws in holes in bottom of unit on opposite side.
- Replace the grille.

## Light Bulb Replacement

To replace the light bulb in your U-Line unit:



**Figure 33**

1. Grasp the edges of the light housing lens (**Figure 33, 1**) opposite the exposed tab and gently push the lens toward the tab (**Figure 33, 2**).
2. Pull the edge of the lens down (**Figure 33, 1**) and swing it out of the light housing.

### IMPORTANT

**ALWAYS use a genuine U-Line replacement bulb (P/N 31317) in the light housing. Use of any other bulb within the housing will generate excessive heat, causing damage to the light housing and cabinet interior, and will compromise the precise temperature control of your unit.**

3. Replace the bulb only with a genuine U-Line P/N 31317 replacement.
4. Replace the lens by first inserting the tab side back into the housing at a slight angle. While gently pushing the lens towards the tab end, push the free end up into the housing, and release when you will hear a snap/click.

## Wine Rack Removal/Installation

To remove a rack from the cabinet:

1. Grasp the end of the rack, and gently slide it out until it stops.
2. Remove any bottles stored on the rack.

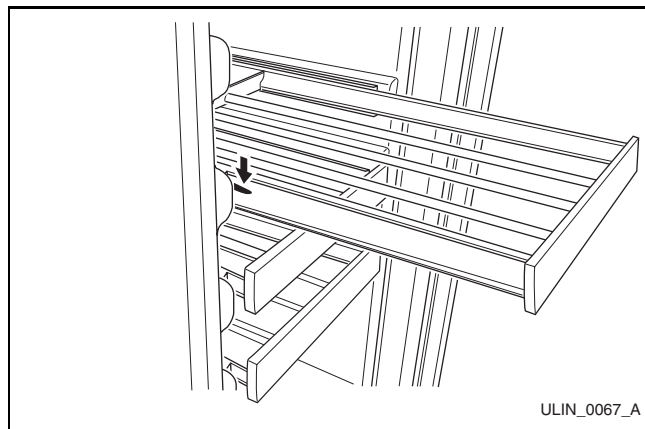

**Figure 34**

3. Press the left rack release lever (**Figure 34**) down, and at the same time, lift the corresponding right rack release lever up, and pull the rack out until it is free of the tracks and the cabinet.

### IMPORTANT

**Do not remove the track side rails from the cabinet.**

To insert a rack in the cabinet:

1. Align the left and right rack channels with the tracks in the cabinet, and ensuring an even track engagement on both sides, gently push the rack into the cabinet until it stops.
2. Before reloading the rack, ensure proper operation of the travel stops in the left and right track rails by pulling the rack out gently until it completely stops.

## Wood Trim Finishing

Interior components of your U-Line unit are equipped with a natural wood trim for appearance and durability. Although this wood trim has been coated with a clear sealer at the factory, it is recommended that the trim be stained (if desired), and receive a final finish coating prior to the unit going into full-time service.

### **WARNING**

**To prevent permanent damage to the inner liner of your unit, the wood trim MUST be removed from the unit for staining and/or finishing. Allow stain/finish to dry thoroughly (at least 24 hours per coat) in accordance with the product manufacturer's instructions prior to reinstallation. Failure to do so may cause the inner liner of the unit to have a permanent odor, which is not covered by the warranty.**

If staining the trim is desired, it must be done before the application of any type of final finish. Review the following staining/final finish and final finish-only guidelines when staining/ and or sealing the wood to ensure proper adhesion and durability of the finish.

**NOTE: Glass in door is tinted. Stain may look darker when door is closed.**

#### **Staining and final finish application:**

1. Remove all screws securing wood trim to interior components, and remove the trim from the cabinet interior.

**NOTE:** Your model may contain an electronic display panel in the lowest level trim piece. After removing the trim screws, and gently pulling the trim from its location, a wiring harness connector will become visible. Unplug the connector, and remove the trim from the interior.

### **IMPORTANT**

**DO NOT use oil-based stains on wood trim. Vapors from oil-based stains will permanently penetrate the liner and will not dissipate over time.**

2. Apply Minwax® Water-Based Wood Stain to wood with a synthetic bristle brush or a foam applicator. Allow stain to penetrate approximately three minutes. Before the stain is dry, take a stain dampened rag and remove any excess stain remaining. Wipe in the direction of the grain with medium pressure to achieve the desired stain color.
3. After two hours, repeat step 2. This will even out the color of the wood.
4. Allow stain to dry for a minimum of three hours before applying the final finish.
5. If desired, sand the wood with very fine sandpaper to smooth the surface after the staining process.

6. Remove all dust from the wood, and apply one coat of Minwax® Polycrylic® Protective Finish using a synthetic bristle brush to the wood. This finish should be applied in a thin coat following the direction of the grain. Apply the finish to the back and sides of the wood first, and allow it to dry for two hours. Apply the finish to the front side of the wood next, and allow it to dry for two hours. Sand with very fine 220 grit sandpaper. Apply two addition coats of the finish in the same manner, but do not sand the trim after the final third coat is applied.
7. Allow the final coat to dry for 24 hours before reinstalling the trim to the cabinet interior components.

#### **Final finish-only application:**

1. Remove all screws securing wood trim to interior components, and remove the trim.
2. Lightly scuff sand the wood trim with 280 or finer grit sandpaper.
3. Remove sanding dust with a clean, dry cloth.
4. The factory-applied seal is compatible with virtually all finishes. A low odor, water clean up, quick-drying finish such as Minwax® Polycrylic® Protective Finish is recommended (Minwax® Polycrylic® is an ultra fast-drying water-based finish). Apply a thin coat of a clear, protective finish, following the container label directions.
5. Lightly sand and reapply if desired.
6. Allow the final coat to dry for 24 hours before reinstalling the trim to the cabinet interior components.

**8 Service**

---

**Before Calling for Service**

If your U-Line product appears to be malfunctioning, read through the OPERATION section of this guide to ensure that the function of all controls are clearly understood. If the malfunction persists, the TROUBLESHOOTING GUIDE in this guide will assist you in quickly identifying common problems, and provide information on possible causes and remedies. Most often, this will resolve the problem without the need to call for service.

**If Service is Required**

If you do not understand a troubleshooting remedy, or your product needs service, contact U-Line Corporation directly. Contact information appears on the rear cover of this guide.

You will be asked for your product Model and Serial Numbers. This information should be recorded inside the front cover of this guide, following the products original purchase. It also appears on the Model and Serial number plate located on the upper right or rear wall of the interior of your product.

**Replacement Parts**

When you need replacement parts, always request that genuine U-Line replacements be used. U-Line products have been designed and engineered using components that work efficiently, and provide superior service life and performance. The use of aftermarket parts or components may affect the safety, operation, performance or durability of your product, and may also void its warranty.

## Troubleshooting Guide



### **ELECTROCUTION HAZARD**

**Never attempt to repair or perform maintenance on the unit until the main electrical power has been disconnected.**

**Troubleshooting - What to check when problems occur:**

PROBLEM	POSSIBLE CAUSE	REMEDY
Unit does not operate and electronic display is blank.	No electrical supply	Plug unit in or check circuit breaker.
No interior light	Loose or burned out bulb	Tighten or replace bulb (See MAINTENANCE; LIGHT BULB REPLACEMENT).
Unit not cold enough. Check temperatures (see OPERATION for approximate temperatures).	Control set too warm	Set control to a cooler setting (See OPERATION). Allow 24 hours for temperature to stabilize.
	High ambient temperature or exposure to direct sunlight	Reposition unit.
	Airflow to front grille blocked	Airflow must not be obstructed to front grille (See OPERATION).
	Dirty condenser coils	Clean condenser (See MAINTENANCE; CONDENSER CLEANING).
	Light staying on	Adjust door (See MAINTENANCE; DOOR ALIGNMENT CHECK AND ADJUSTMENT).
	Door gasket not sealing properly	Adjust door (See MAINTENANCE; DOOR ALIGNMENT CHECK AND ADJUSTMENT).
Unit is too cold. Check temperatures (see OPERATION for approximate temperatures).	Control set too cold	Set control to a warmer setting (See OPERATION). Allow 24 hours for temperature to stabilize.
Electronic display is blank and interior light is OFF with door OPEN.	Unit is in blackout/Sabbath mode (not Star K certified).	Exit blackout/Sabbath mode (not Star K certified) (See OPERATION).
Electronic display is blank and interior light is ON with door OPEN.	A display function has changed.	Touch and hold the WARMER button and touch and release the ON/OFF button three times, then release the temperature button. The display should become visible.
Electronic display shows repeating, randomly flashing symbols and partial characters.	A factory control mode has been inadvertently entered.	Touch and hold the warmer temperature button and touch and release the LIGHT button three times, then release the temperature button to exit the factory control mode. The set-point temperature should now be displayed.
Electronic display shows: 0, 1 to 16, or 99	A factory control mode has been inadvertently entered.	Repeatedly touch the WARMER button to advance any number shown to 99 and touch and release the LIGHT button. The set-point temperature should now be displayed.
Electronic display shows one or more of the following: E1, E2, E4, E5, E6, E7, E8, E9, E10, P1.	The unit is displaying an error code.	Record the error code(s) displayed and call for service.

## Electronic Control Quick Guide

Task	Touch	Touch	Display	Comment
Turn ON/OFF	Hold 10 seconds	Release when °F flashes.	or	
Adjust Temperature	or  Touch and release	or  Touch to change temperature		°F flashes after first touch, set-point saved after 5 seconds of inactivity and °F stops flashing.
View Actual Temp	Hold 5 seconds	Release when °F flashes.		WC models will scroll top/mid/bottom temps.
Change F/C	Hold		or	
Blackout Mode	Hold 10 seconds		Display (and cabinet light) will not operate in Blackout Mode.	Blackout will end in 36 hours, or hold again to terminate early.

### Glass Door Models Only

Cabinet Light				Light normally goes on/off with door opening. Pressing light button will turn interior light on for 4 hours, then it will turn off.
Display Off Mode				Display off when door is closed (unless cabinet light is turned on). Repeat to switch back.

**NOTE:** 38°F is an example; the display will vary with actual set-point.

### IMPORTANT

**Factory recommended set-point is 38°F for refrigerators and beverage centers, and 50°F for wine coolers.**

This page intentionally left blank



---

This page intentionally left blank

This page intentionally left blank

## U-Line Corporation Limited Warranty

U-Line Corporation warrants each U-Line product to be free from defects in materials and workmanship for a period of one year from the date of purchase; and warrants the sealed system (consisting of the compressor, the condenser, the evaporator, the hot gas bypass valve, the dryer and the connecting tubing) in each U-Line product to be free from defects in materials and workmanship for a period of five years from the date of purchase. During the initial one-year warranty period for all U-Line products U-Line shall: (1) at U-Lines option, repair any product or replace any part of a product that breaches this warranty; and (2) for all Marine, RV and Domestic U-Line products sold and serviced in the United States (including Alaska and Hawaii) and Canada, U-Line shall cover the labor costs incurred in connection with the replacement of any defective part. During years two through five of the warranty period for the sealed system, U-Line shall: (1) repair or replace any part of the sealed system that breaches this warranty; and (2) for all Marine, RV and Domestic U-Line products sold and serviced in the United States (including Alaska and Hawaii) and Canada, U-Line shall cover the labor costs incurred in connection with the replacement of any defective part of the sealed system. All other charges, including transportation charges for replacements under this warranty and labor costs not specifically covered by this warranty, shall be borne by you. This warranty is extended only to the original purchaser of the U-Line product. The Registration Card included with the product should be promptly completed by you and mailed back to U-Line or you can register on-line at [www.U-LineService.com](http://www.U-LineService.com).

The following are excluded from this limited warranty: installation charges; damages caused by disasters or acts of God, such as fire, floods, wind and lightening; damages incurred or resulting from shipping, improper installation, unauthorized modification, or misuse/abuse of the product; customer education calls; food loss/spoilage; door and water level adjustments (except during the first 90 days from the date of purchase); defrosting the product; adjusting the controls; door reversal; or cleaning the condenser.

If a product defect is discovered during the applicable warranty period, you must promptly notify either the dealer from whom you purchased the product or U-Line at P.O. Box 245040, Milwaukee, Wisconsin 53224 or at 414-354-0300. In no event shall such notification be received later than 30 days after the expiration of the applicable warranty period. U-Line may require that defective parts be returned, at your expense, to U-Lines factory in Milwaukee, Wisconsin, for inspection. Any action by you for breach of warranty must be commenced within one year after the expiration of the applicable warranty period.

**This limited warranty is in lieu of any other warranty, express or implied, including, but not limited to any implied warranty of merchantability or fitness for a particular purpose; provided however, that to the extent required by law, implied warranties are included but do not extend beyond the duration of the express warranty first set forth above. U-Lines sole liability and your exclusive remedy under this warranty is set forth in the initial paragraph above. U-Line shall have no liability whatsoever for any incidental, consequential or special damages arising from the sale, use or installation of the product or from any other cause whatsoever, whether based on warranty (express or implied) or otherwise based on contract, tort or any other theory of liability.**

Some states do not allow limitations on how long an implied warranty lasts or the exclusion or limitation of incidental or consequential damages, so the above limitations may not apply to you. This warranty gives you specific legal rights, and you may also have other rights which vary from state to state.



**For General Inquiries:**

P.O. Box 245040  
Milwaukee, Wisconsin  
53224-9540 U.S.A.  
Phone (800) 779-2547  
FAX (414) 354-5696  
[www.U-Line.com](http://www.U-Line.com)

**For Service and Parts Assistance:**

Phone (800) 779-2547  
(414) 354-0300  
FAX (414) 354-5696  
Email:  
[OnLineService@U-Line.com](mailto:OnLineService@U-Line.com)  
[www.U-LineService.com](http://www.U-LineService.com)  
E-mail:  
[OnlineParts@u-line.com](mailto:OnlineParts@u-line.com)

# *O r i g i n s      S e r i e s*

For more than four decades, U-Line has distinguished itself as the leader in built-in under-counter ice making, refrigeration and wine storage appliances.

An INSTALLATION MANUAL for your unit, providing complete installation information, is available for download at [www.U-Line.com](http://www.U-Line.com). Information for custom panel inserts per model, including panel size, and instructions are available by visiting [www.U-Line.com](http://www.U-Line.com).

When you need replacement parts, always request genuine U-Line replacements be used. Visit [www.U-Line.com](http://www.U-Line.com) to locate a parts distributor in your area.

*Echelon™* SERIES / *O r i g i n s* SERIES

U-Line Corporation, located in Milwaukee, WI, is a family operated manufacturer of built-in undercounter ice makers, Combo® ice maker/refrigerators, Wine Captain® wine storage units, refrigerators, refrigerated drawers and refrigerator/freezers.