

EUREKA

We live and breathe clean.™

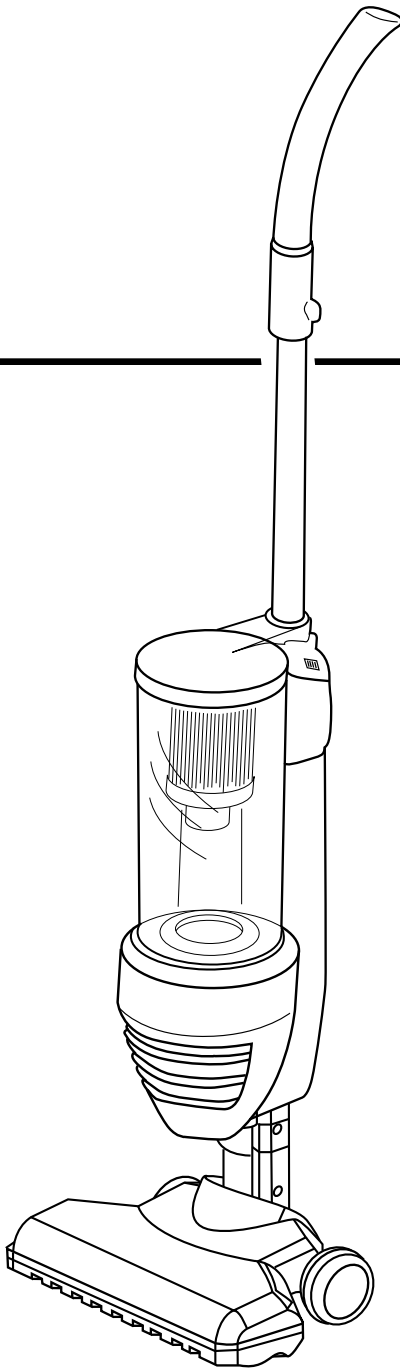

Vacuum Cleaner Household Type OWNER'S GUIDE 420 Series

IMPORTANT

Do not return to the store. For assembly problems or questions, for replacement of broken or missing items, or to order replacement parts and accessories to be shipped direct to you contact:

Eureka Customer Service toll free at 1-800-282-2886, 8 a.m. to 7:30 p.m. (CST), Monday - Friday and 10 a.m. to 6:30 p.m. Saturday. Or visit our web site, www.eureka.com

*En Mexico llame al (55) 5343-4384

Index

Important Information	2
Assemble.....	3
Use	4
Maintenance	4-5
Filter.....	4-5
Warranty	5

PLEASE RETAIN

We suggest you record the model, type and serial numbers below. They are located on the silver rating plate on your cleaner. For prompt and complete service information, always refer to these numbers when inquiring about service.

Model & Type _____

Serial No. _____

It is also important to keep your receipt as proof of date of purchase.

IMPORTANT SAFEGUARDS

When using an electrical appliance, basic precautions should always be followed, including the following:

READ ALL INSTRUCTIONS BEFORE USING THIS VACUUM CLEANER.

WARNING

To reduce the risk of fire, electric shock, or injury :

- Do not use outdoors or on wet surfaces.
- **Do not leave vacuum cleaner when plugged in.** Turn off the switch and unplug the electrical cord when not in use and before servicing.
- Do not allow to be used as a toy. Close attention is necessary when used by or near children.
- Use only as described in this manual. Use only manufacturer's recommended attachments.
- Do not use with damaged cord or plug. If vacuum cleaner is not working as it should, has been dropped, damaged, left outdoors, or dropped into water, return it to a service center before using.
- Do not pull or carry by cord, use cord as a handle, close door on cord, or pull cord around sharp edges or corners. Do not run vacuum cleaner over cord. Keep cord away from heated surfaces.
- Do not use extension cords or outlets with inadequate current carrying capacity.
- Turn off all controls before unplugging.
- Do not unplug by pulling on cord. To unplug, grasp the plug, not the cord.
- Do not handle plug or vacuum cleaner with wet hands or operate without shoes.
- Do not put any object into openings. Do not use with any opening blocked; keep free of dust, lint, hair, and anything that may reduce airflow.
- This vacuum cleaner creates suction and contains a revolving brushroll. Keep hair, loose clothing, fingers, and all parts of body away from openings and moving parts.
- Do not pick up anything that is burning or smoking, such as cigarettes, matches, or hot ashes.
- Do not use without dust cup or filter in place.
- Use extra care when cleaning on stairs.
- Do not use to pick up flammable or combustible liquids such as gasoline, or use in areas where they may be present.
- Store your cleaner indoors in a cool, dry area.
- Keep your work area well lighted.
- Unplug electrical appliances before vacuuming them.

SAVE THESE INSTRUCTIONS

To reduce the risk of electric shock, this appliance has a polarized plug (one blade is wider than the other). This plug will fit in a polarized outlet only one way. If the plug does not fit fully into the outlet, reverse the plug. If it still does not fit, contact a qualified electrician to install the proper outlet. Do not change the plug in any way.



DO NOT OIL the motors or brushroll. The motors and brushroll are permanently sealed and lubricated.

GENERAL INFORMATION

Use the cleaner to pick up dirt and dust particles. Avoid picking up hard or sharp objects that could damage the vacuum cleaner.

Service Information

The instructions in this booklet serve as a guide to routine maintenance. For additional service information, telephone our toll free number for the nearest Eureka Authorized Warranty Station. **You should know the model, type and serial number or date code when you call :**

**USA : 1-800-282-2886 Mexico : 5670-6169
Canada : 1-800-282-2886**

If you prefer, you can write to Electrolux Home Care Products North America, Consumer Service, P. O. Box 3900, Peoria, Illinois, 61612, USA. In Canada, write to Electrolux Home Care Products Canada, 866 Langs Drive, Cambridge, Ontario N3H 2N7. Refer to The Eureka Warranty for complete service information.

Automatic Motor Shut-Off

To protect from overheating, this vacuum cleaner is equipped with a thermostat which automatically shuts off the suction motor if it overheats. Should this happen:

1. **Turn off the switch and unplug the cleaner** because the thermostat will allow the cleaner to automatically start running again when the motor cools (approximately 30 minutes).
2. **Check the dust cup and filter** regularly, as a full dust cup or dirty filter could cause the motor to overheat.
3. **Call a Eureka Authorized Warranty Station** if the cleaner will not operate after cooling for approximately 30 minutes.

IDENTIFY PARTS

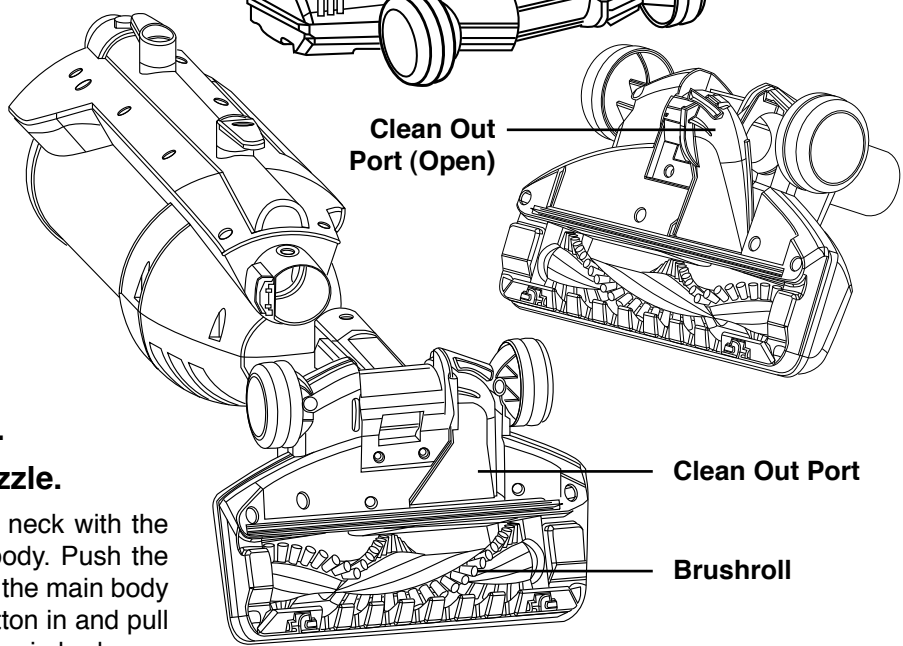
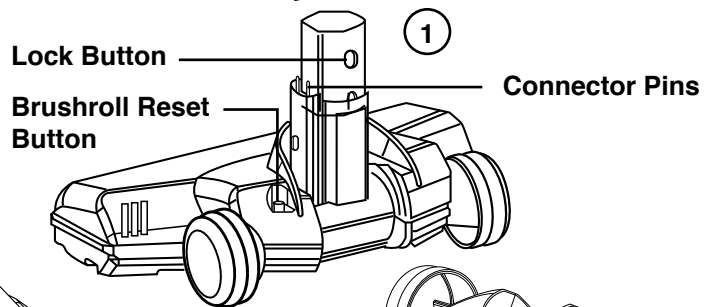
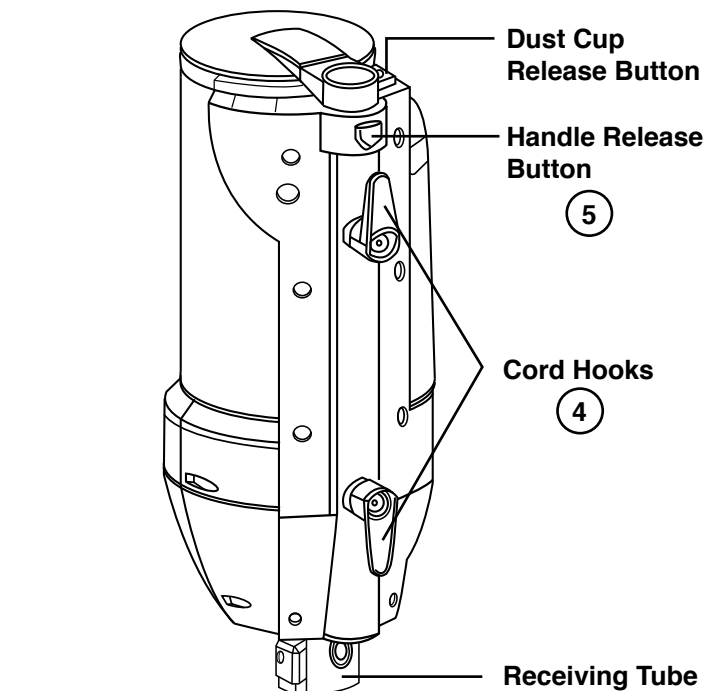
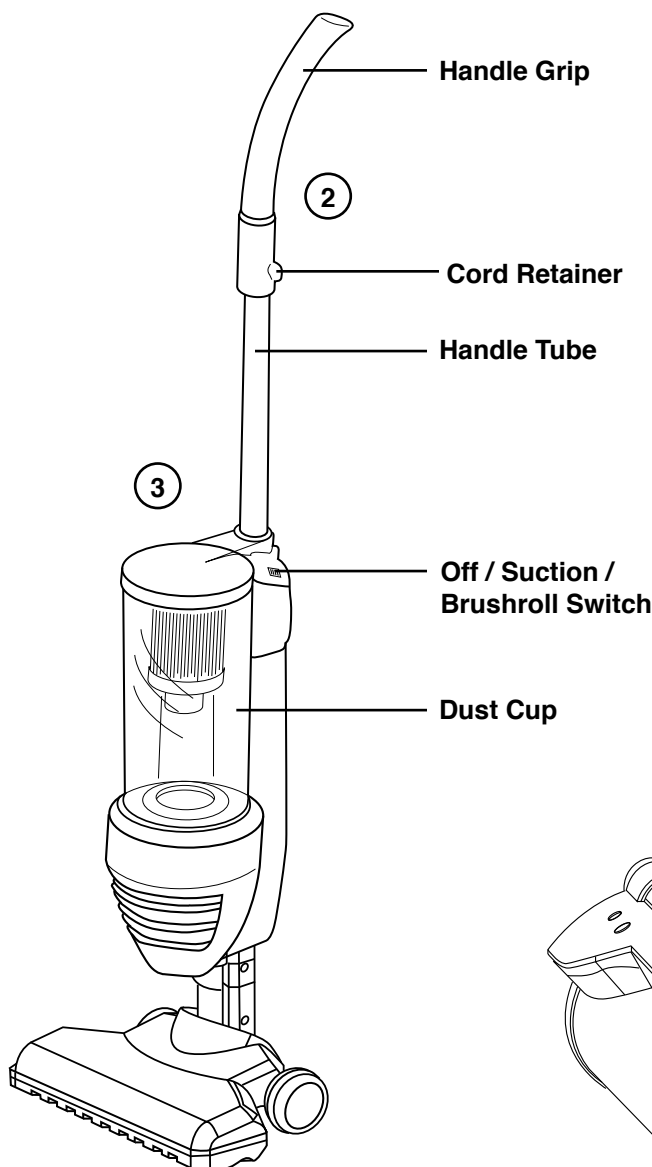

HOW TO ASSEMBLE

Assemble completely before using.

1. Attaching or Removing Floor Nozzle.

Align the lock button on the floor nozzle neck with the hole in the receiving tube on the main body. Push the lock button and slide the floor nozzle into the main body until it clicks into place. Push the lock button in and pull on the floor nozzle to remove it from the main body.

2. Attach Handle Grip.

Align the lock button on the handle tube with the hole in the handle grip. Push the lock button and slide the handle into place.

3. Attach handle tube to the cleaner.

Insert the end of the handle tube with the guide tabs into the cleaner. Push the handle release button to get the handle tube fully inserted. The handle is properly inserted when you hear a click.

4. Store Cord (using cord hooks).

Pull the electrical cord down around the lower cord hook, then wrap cord around upper and lower cord hooks. Fasten plug to electrical cord to prevent unwinding.

5. Store Unit.

Push the telescoping handle release button to lower the handle into its compact storage position. The handle is locked down when a click is heard.

HOW TO USE

Power Switch

1. This vacuum has a 3-position switch. O is Off, I is "Suction Only," and II is "Suction and Brushroll."
2. For bare floor cleaning use suction only (I). For carpet cleaning, use suction and brushroll (II).

The nozzle allows for low profile cleaning. Airflow under the nozzle automatically directs suction to the edges and corners for maximum full width cleaning.

HOW TO MAINTAIN

The instructions in this booklet serve as a guide to routine maintenance. To keep the cleaner operating at top efficiency empty the dust cup and clean the filter after each use. To maximize cleaner efficiency do not allow the dust cup to be filled past the bottom of the filter.

Empty Dust Cup

CAUTION: Turn off the power switch and unplug the electrical cord to service.

3. Push dust cup release button.
4. Pull the dust cup away from the main housing.
5. Rotate the dust cup lid counterclockwise to remove. The dust cup filter comes out with the dust cup lid.
6. Empty the dust cup into a waste container. (To clean filter refer to dust cup filter section.)
7. Put the lid back on dust cup. Be sure the gasket on the filter bottom is centered in the inner tube and the lid is aligned correctly on the cup. Rotate the dust cup lid clockwise until it locks.
8. Place the bottom of the dust cup in the main housing. Push the top of the dust cup back into place until it locks.

Remove a Clog in the Base

This model has a clean-out port which allows access into the bottom of the power nozzle in order to remove large debris that has become lodged in the airway. (See page 3 for location.)

CAUTION: Turn off the power switch and unplug the electrical cord to service.

1. On the bottom of the power nozzle, locate the transparent Clean-Out Port Door located between the wheels. (See page 3.)
2. Remove the port door by squeezing the latch at the back of the nozzle and rotating the port door forward. No tools are needed for this step.
3. Locate and remove clog from the power nozzle.
4. Reattach the clean-out port door by inserting the front edge into position and rotating the door into the base until the latch snaps into place. Ensure that the latch is secure. Do not use the vacuum without first reattaching the clean-out port door.
5. If needed, you may remove the power nozzle from the main body of the cleaner to locate the clog in the neck of the power nozzle.

Brushroll Reset Switch

This vacuum comes equipped with a Brushroll circuit protector which turns the brushroll off in the event of a stall situation. The reset switch is located at the rear of the power nozzle. (see page 3)

CAUTION: Turn off the power switch and unplug the electrical cord to service.

1. Turn off the vacuum and unplug it.
2. Remove the obstruction from the brushroll.
3. Plug the cleaner back in, press the reset switch and then turn the vacuum on to continue cleaning.
4. Periodically remove hair and threads from the brushroll.

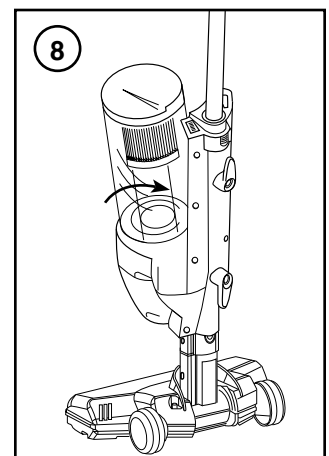
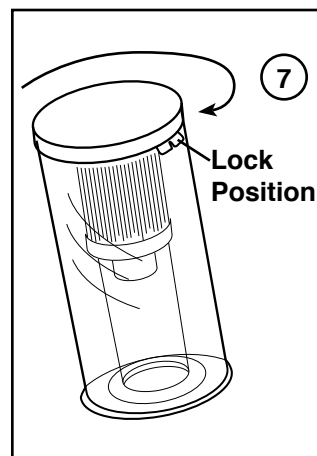
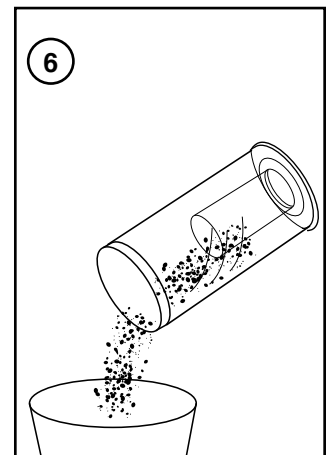
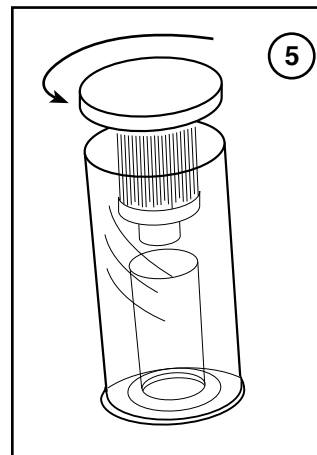
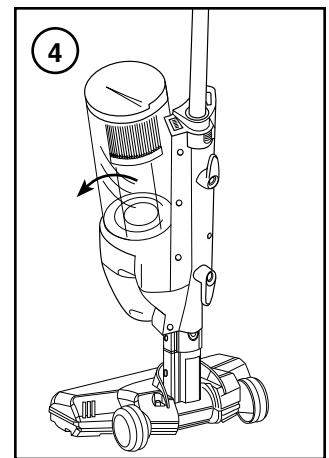
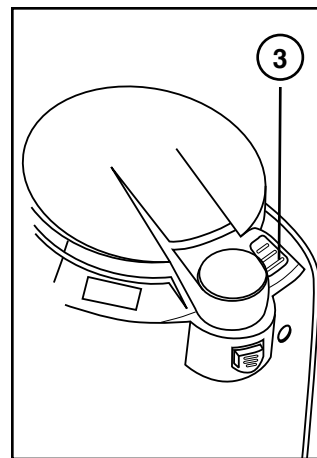
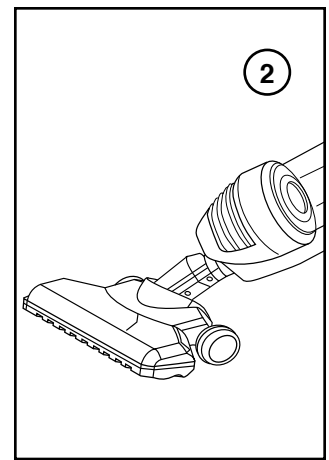
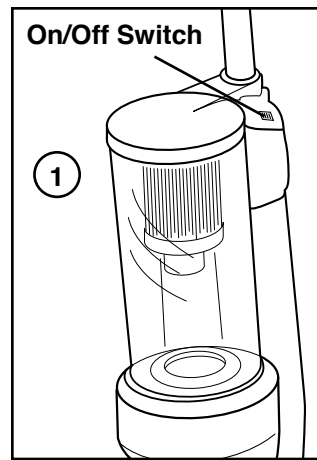

Clean Dust Cup Filter



CAUTION: Turn off the power switch and unplug the electrical cord to service.

Clean dust cup filter as necessary.

1. Remove dust cup.
2. Remove dust cup lid and filter assembly.
3. Shake and brush the dust and dirt from filter. If desired, launder the filter by hand in warm water using a mild detergent. The filter may be washed up to 6 times. Air dry thoroughly.



NOTE: The dust cup filter is not dishwasher safe. Do not put in dishwasher.

4. Replace filter in dust cup by twisting the dust cup lid firmly into place to ensure proper filter performance.
5. Place bottom of dust cup in main housing. Push top of dust cup back into place until it locks.

You may order replacement filters from Electrolux Home Care Products N.A., Consumer Service, P. O. Box 3900, Peoria, Illinois 61612. Order dust cup filter, part number 62351-3. To place an order please telephone 1-800-282-2886.

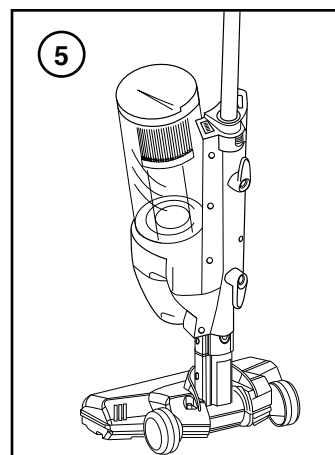
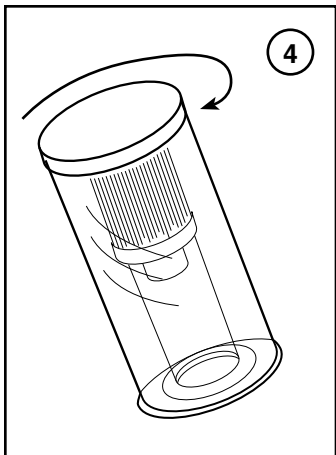
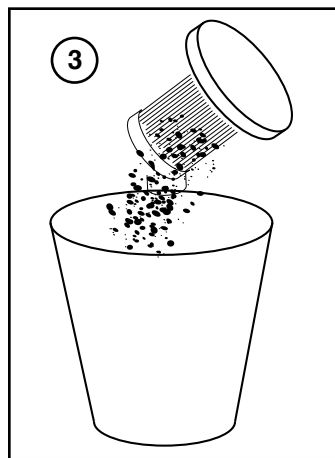
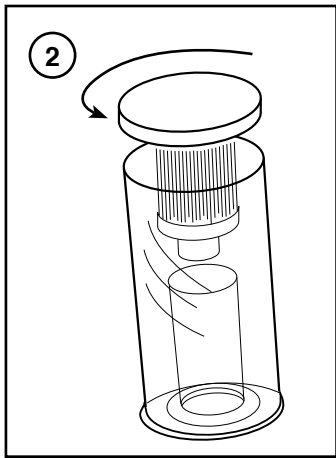

THE EUREKA LIMITED WARRANTY

What This Warranty Covers

Your Eureka cleaner is warranted to be free from all defects in material and workmanship in normal household use for a period of one year. The warranty is granted only to the original purchaser and members of his or her immediate household. The warranty is subject to the following provisions.

What This Warranty Does Not Cover

- Parts of the cleaner that require replacement under normal use, such as disposable dust bags, filters, drive belts, light bulbs, and brush roll bristles, impellers and cleaning.
- Damages or malfunctions caused by negligence, abuse, or use not in accordance with the Owner's Guide.
- Defects or damages caused by unauthorized service or the use of other than Genuine Eureka parts.

What the Manufacturer Will Do

The manufacturer will, at its option, repair or replace a defective cleaner or cleaner part that is covered by this warranty. As a matter of warranty policy, the manufacturer will not refund the consumer's purchase price.

Warranty Registration

Please fill out and return the warranty registration card accompanying your cleaner.

Obtaining Warranty Service

To obtain warranty service you must return the defective cleaner or cleaner part along with proof of purchase to any Eureka Authorized Warranty Station.

You will find the nearest location in the Yellow Pages, under "Vacuum Cleaners - Service and Repair." Be certain that the Warranty Station is "Eureka Authorized."

For the location of the nearest Eureka Authorized Warranty Station or for service information, telephone toll free:

USA: 1-800-282-2886
Mexico: (55) 5343-4384
Canada: 1-800-282-2886

If you prefer you can write to Electrolux Home Care Products North America, P O Box 3900, Peoria, Illinois 61612, USA. In Canada write to Electrolux Home Care Products Canada, 866 Langs Drive, Cambridge, Ontario N3H 2N7.

If it is necessary to ship the cleaner outside your community to obtain warranty repair, you must pay the shipping charges to the Eureka Authorized Warranty Station.

Return shipping charges will be paid by the Warranty Station. When returning parts for repair, please include the model, type, and serial number from the data plate on the cleaner.

Further Limitations and Exclusions

Any warranty that may be implied in connection with your purchase or use of the cleaner, including any warranty of Merchantability or any warranty for Fitness For A Particular Purpose is limited to the duration of this warranty. Some states do not allow limitations on how long an implied warranty lasts, so the above limitations may not apply to you.

Your relief for the breach of this warranty is limited to the relief expressly provided above. In no event shall the manufacturer be liable for any consequential or incidental damages you may incur in connection with your purchase or use of the cleaner. Some states do not allow the exclusion or limitation of incidental or consequential damages, so the above limitation or exclusion may not apply to you.

This warranty gives you specific legal rights. You may also have other rights which vary by state.



Questions & Answers about Genuine Eureka Products

Q: Why should I use only Genuine Eureka paper bags, belts, and parts in my Eureka vacuum cleaner?

A: Using Genuine Eureka Products, which are made to exacting specifications and engineered with emphasis on quality, performance, and customer satisfaction, ensures the long life and cleaning efficiency of your vacuum cleaner. Overall, this saves you money and helps to keep your home clean.

Q: How can I be sure I am using only genuine Eureka products in my vacuum cleaner?

A: Typically, packaged products and paper bags can be identified by a "Genuine Eureka Product" symbol (see illustration above). For further identification assistance, you may call our toll-free number, 1-800-282-2886, for the location of a nearby Eureka Authorized Warranty Station.

Q: Are there any differences between "made to fit" or "imitation" and Genuine Eureka paper bags, belts, and parts?

A: Yes, there are some very important differences in materials, quality, and reliability. Many customers have mistakenly purchased "imitation" paper bags and parts while thinking they purchased genuine. Unfortunately, many of these customers discovered the differences after they experienced related difficulties.

For Genuine Eureka Value, Accept No Imitations!