



**TECHNICAL INFORMATION**  
**CVA610 Coffee System**



# CVA610 Coffee System - Table of Contents

## 1.0 CONSTRUCTION & DESIGN

1.1 Appliance Overview	1
1.2 Technical Data	3
1.3 Layout of Components	5

## 2.0 INSTALLATION

Installation Procedures	7
-------------------------	---

## 3.0 COMMISSION and OPERATION

3.1 General Operation	9
3.1.1 Preparing Coffee	9
3.1.2 Canceling the Preparation	10
3.1.3 Steam Control	10
3.1.4 Hot Water Dispensing	11
3.1.5 Adjusting the Coffee Grinder	12
3.1.6 Filling the Coffee Bean Container	13
3.1.7 Filling the Water Tank	14

## 4.0 DESCRIPTION of FUNCTION

4.1 Door Switch	15
4.2 Overflow Switch	15
4.3 Brew Unit – Home Position	16
4.4 Brew Unit – Drive & Water Connections	17
4.5 Brewing Procedure	18
4.6 Waste Unit	21
4.7 Waste Unit Present Switch	21
4.8 Water Tank	23
4.9 Water Level Switch	24
4.10 Grinder Assembly	25
4.11 Grinder – Overload Protection	26
4.12 Ground Coffee – Dispensing	28
4.13 Brew Unit Drives	30
4.14 Water Pump	32
4.15 Flow meter	33
4.16 Heater – Data	33
4.17 Heaters	34

#### 4.0 DESCRIPTION of FUNCTION (Continued)

4.18 Water Path	36
4.18.1 Water Intake	37
4.18.2 Water Path - Coffee	37
4.18.3 Water Path – Hot Water	37
4.18.4 Water Path - Steam	37
4.18.5 Steam Valve and Steam Valve Switch	37
4.19 Heater Outlet Valve (Nipple)	38
4.20 Electronic Assembly	39

#### 5.0 SERVICE and MAINTENANCE

5.1 Lid – Removal	41
5.2 Mains Filter – Removal	41
5.3 Rear Panel – Removal	42
5.4 Adjustment Slide Switch Frame - Removal	43
5.5 Door Contact Switch - Removal	44
5.6 Base Plate - Removal	45
5.7 Drip Tray - Removal	46
5.8 Overflow Switch Actuator Float - Removal	47
5.9 Overflow Switch - Removal	48
5.10 Fluorescent Lamp – Removal	49
5.11 Lamp Starter - Removal	49
5.12 Rear Door Panel – Removal	50
5.13 Fascia Panel Cover – Replacement	51
5.14 Selector Switch - Removal	52
5.15 Display Module Electronic – Removal	53
5.16 Coffee Dispensing Nozzle – Removal	54
5.17 Coffee Dispensing Nozzle - Fitting	55
5.18 Steam Valve and Steam Valve Switch - Removal	56
5.19 Hot Water Nozzle - Removal	57
5.20 Hot Water Nozzle - Removal	58
5.21 Coffee Temperature - Check	58
5.22 Brew Unit – Removal (in start/home position)	58
5.23 Brew Unit – Removal (NOT in start//home position)	59
5.24 Brew Unit – Installation	61
5.25 Brew Unit – Cleaning Procedure	61

## 5.0 SERVICE and MAINTENANCE (Continued)

<u>5.26 Brew Unit – Filter Cleaning</u>	<u>62</u>
<u>5.27 Brew Unit – Degreasing via the Rinse Cycle</u>	<u>63</u>
<u>5.28 Brew Unit – Lubrication</u>	<u>65</u>
<u>5.29 Brew Unit – Manual Reset to “Home Position” (Brew Unit Not Installed)</u>	<u>66</u>
<u>5.30 Brew Unit Creamer Valve – Removal</u>	<u>67</u>
<u>5.31 Brew Unit Handle – Removal</u>	<u>67</u>
<u>5.32 Brew Unit Funnel – Removal</u>	<u>68</u>
<u>5.33 Brew Unit Ram – Service</u>	<u>69</u>
<u>5.34 Water Tank Level Indicator Float – Removal</u>	<u>71</u>
<u>5.35 Water Tank Sealing Ring – Removal</u>	<u>72</u>
<u>5.36 Lower Section of Tank Valve – Removal</u>	<u>73</u>
<u>5.37 Bean Container – Removal</u>	<u>75</u>
<u>5.38 Bean Container Guide – Removal</u>	<u>76</u>
<u>5.39 Grinder Unit – Disassembly</u>	<u>77</u>
<u>5.40 Grinder Unit – Assembly &amp; Basic Setting</u>	<u>80</u>
<u>5.41 Grinder Unit – Removal</u>	<u>81</u>
<u>5.42 Brew Unit Present Switch – Removal</u>	<u>83</u>
<u>5.43 Dispensing Solenoid – Removal</u>	<u>83</u>
<u>5.44 Dispenser Switch – Removal</u>	<u>83</u>
<u>5.45 Brew Unit Drives – Home Positioning</u>	<u>84</u>
<u>5.46 Waterpath / Flowmeter Check</u>	<u>84</u>
<u>5.47 Waterpath Leakage Test</u>	<u>85</u>
<u>5.48 Water Connections – Releasing</u>	<u>86</u>
<u>5.49 Water Connections – Fitting</u>	<u>87</u>

## 6.0 FAULT DIAGNOSIS

<u>6.1 Programming Mode</u>	<u>89</u>
<u>6.2 Service Mode</u>	<u>90</u>
<u>6.3 Displayed Messages</u>	<u>92</u>
<u>6.4 Uneven Filling</u>	<u>94</u>
<u>6.5 Brew Unit – Can't be removed from appliance</u>	<u>94</u>
<u>6.6 Brew Unit – Can't be installed</u>	<u>94</u>
<u>6.7Grinder Setting – Can't be set to finer position</u>	<u>95</u>

## CVA610 Coffee System – List of Figures

<u>1-1 Appliance Overview (Exterior)</u>	<u>1</u>
<u>1-2 Appliance Overview (Interior)</u>	<u>2</u>
<u>1-3 Product Dimensions</u>	<u>3</u>
<u>1-4 Overview of Components</u>	<u>5</u>
<u>2-1 Installation Information</u>	<u>7</u>
<u>3-1 Coffee cup placed under both dispensers</u>	<u>9</u>
<u>3-2 Pressing the Coffee Button</u>	<u>9</u>
<u>3-3 Displayed Message During Dispensing</u>	<u>9</u>
<u>3-4 Canceling the preparation</u>	<u>10</u>
<u>3-5 Steam Control</u>	<u>10</u>
<u>3-6 Cup placed under hot water dispenser</u>	<u>11</u>
<u>3-7 Hot Water Button</u>	<u>11</u>
<u>3-8 Grinder Adjustment Control</u>	<u>12</u>
<u>3-9 Filling the Coffee Bean Container</u>	<u>13</u>
<u>4-1 Door Contact Switch</u>	<u>15</u>
<u>4-2 Brew Unit in home position</u>	<u>16</u>
<u>4-3 Brew Unit drive connections</u>	<u>17</u>
<u>4-4 Brew Unit Filters</u>	<u>18</u>
<u>4-5 Brew Unit Components</u>	<u>19</u>
<u>4-6 Brew Unit releasing a “puck”</u>	<u>20</u>
<u>4-7 Waste Unit Present Switch</u>	<u>21</u>
<u>4-8 Waste Unit Magnet</u>	<u>22</u>
<u>4-9 Water Tank Valve</u>	<u>23</u>
<u>4-10 Water Level Switch</u>	<u>24</u>
<u>4-11 Water Level Switch Float</u>	<u>24</u>
<u>4-12 Grinder Assembly</u>	<u>25</u>
<u>4-13 Grinder Overload Protection Components</u>	<u>26</u>
<u>4-14 Grinder Cone Ball Positions</u>	<u>27</u>
<u>4-15 Coffee Dispensing Components</u>	<u>28</u>
<u>4-16 Dispensing Lever</u>	<u>29</u>
<u>4-17 Brew Unit Drive Components</u>	<u>30</u>
<u>4-18 Brew Unit Drive Assembly</u>	<u>31</u>
<u>4-19 Water Pump</u>	<u>32</u>
<u>4-20 Hot Water / Coffee Heater</u>	<u>34</u>
<u>4-21 Steam Heater</u>	<u>35</u>
<u>4-22 Water Path</u>	<u>36</u>
<u>4-23 Heater Drainage Nipple</u>	<u>38</u>

## CVA610 Coffee System – List of Figures (Continued)

<u>4-24 Electronic Board (Layout)</u>	<u>39</u>
<u>5-1 Lid and Securing Screws</u>	<u>41</u>
<u>5-2 Mains Filter Mounting</u>	<u>41</u>
<u>5-3 Rear Panel – Removal</u>	<u>42</u>
<u>5-4 Removing the Slide Switch Frame</u>	<u>43</u>
<u>5-5 Door Switch</u>	<u>44</u>
<u>5-6 Base Plate Removal</u>	<u>45</u>
<u>5-7 Drip Tray</u>	<u>46</u>
<u>5-8 Overflow Switch Float</u>	<u>47</u>
<u>5-9 Overflow Switch</u>	<u>48</u>
<u>5-10 Fluorescent Lamp Access and Removal</u>	<u>49</u>
<u>5-11 Starter Removal</u>	<u>49</u>
<u>5-12 Rear Door Panel – Removal</u>	<u>50</u>
<u>5-13 Fascia Panel Cover Assembly</u>	<u>51</u>
<u>5-14 Selector Switch</u>	<u>52</u>
<u>5-15 Rear View of Front Door w/ Panel Removed</u>	<u>53</u>
<u>5-16 Coffee Dispensing Components</u>	<u>54</u>
<u>5-17 Steam Valve and Steam Valve Switch</u>	<u>56</u>
<u>5-18 Hot Water Valve</u>	<u>57</u>
<u>5-19 Brew Unit Connection Socket</u>	<u>60</u>
<u>5-20 Brew Unit Connection Socket Retaining</u>	<u>60</u>
<u>5-21 Brew Unit Removal</u>	<u>61</u>
<u>5-22 Brew Unit Installation</u>	<u>62</u>
<u>5-23 Cleaning Tablet being placed into brew unit</u>	<u>63</u>
<u>5-24 Brew Unit – lubrication points (1)</u>	<u>65</u>
<u>5-25 Brew Unit – lubrication points (2)</u>	<u>65</u>
<u>5-26 Moving the Brew Unit to the home position</u>	<u>66</u>
<u>5-27 Brew Unit in reset position</u>	<u>66</u>
<u>5-28 Brew Unit (output and retaining lugs)</u>	<u>67</u>
<u>5-29 Rear of Brew Unit</u>	<u>68</u>
<u>5-30 Front of Brew Unit</u>	<u>68</u>
<u>5-31 Brew Unit Ram</u>	<u>69</u>
<u>5-32 Brew Unit Chamber</u>	<u>70</u>
<u>5-33 Brew Unit Ram and Filter Removed</u>	<u>70</u>
<u>5-34 Removing cap to tank float</u>	<u>71</u>
<u>5-35 Levering off the Lip Seal Cap</u>	<u>72</u>
<u>5-36 Removing the Lip Seal</u>	<u>72</u>
<u>5-37 Water Tank Lip Seal – Removal</u>	<u>73</u>



## **CVA610 Coffee System – List of Figures (Continued)**

<u>5-38 Underside view of the CVA610</u>	<u>74</u>
<u>5-39 Removing the Bean Container</u>	<u>75</u>
<u>5-40 Removing the Beans Container Guide</u>	<u>76</u>
<u>5-41 Accessing the Grinder</u>	<u>77</u>
<u>5-42 Upper section of the Grinder</u>	<u>78</u>
<u>5-43 Grinder</u>	<u>79</u>
<u>5-44 Grinder Removal</u>	<u>81</u>
<u>5-45 Grinder Coupling</u>	<u>82</u>
<u>5-46 Brew Unit Present Switch</u>	<u>83</u>
<u>5-47 Water System Connection</u>	<u>86</u>

## **CVA610 Coffee System – List of Tables**

<u>5-1 Programming Mode</u>	<u>89</u>
<u>5-2 Service Mode Navigation</u>	<u>91</u>
<u>5-3 Displayed Messages (part 1 of 2)</u>	<u>92</u>
<u>5-4 Displayed Messages (part 2 of 2)</u>	<u>93</u>



# 1.0 Construction and Design

## 1.1 Appliance Overview

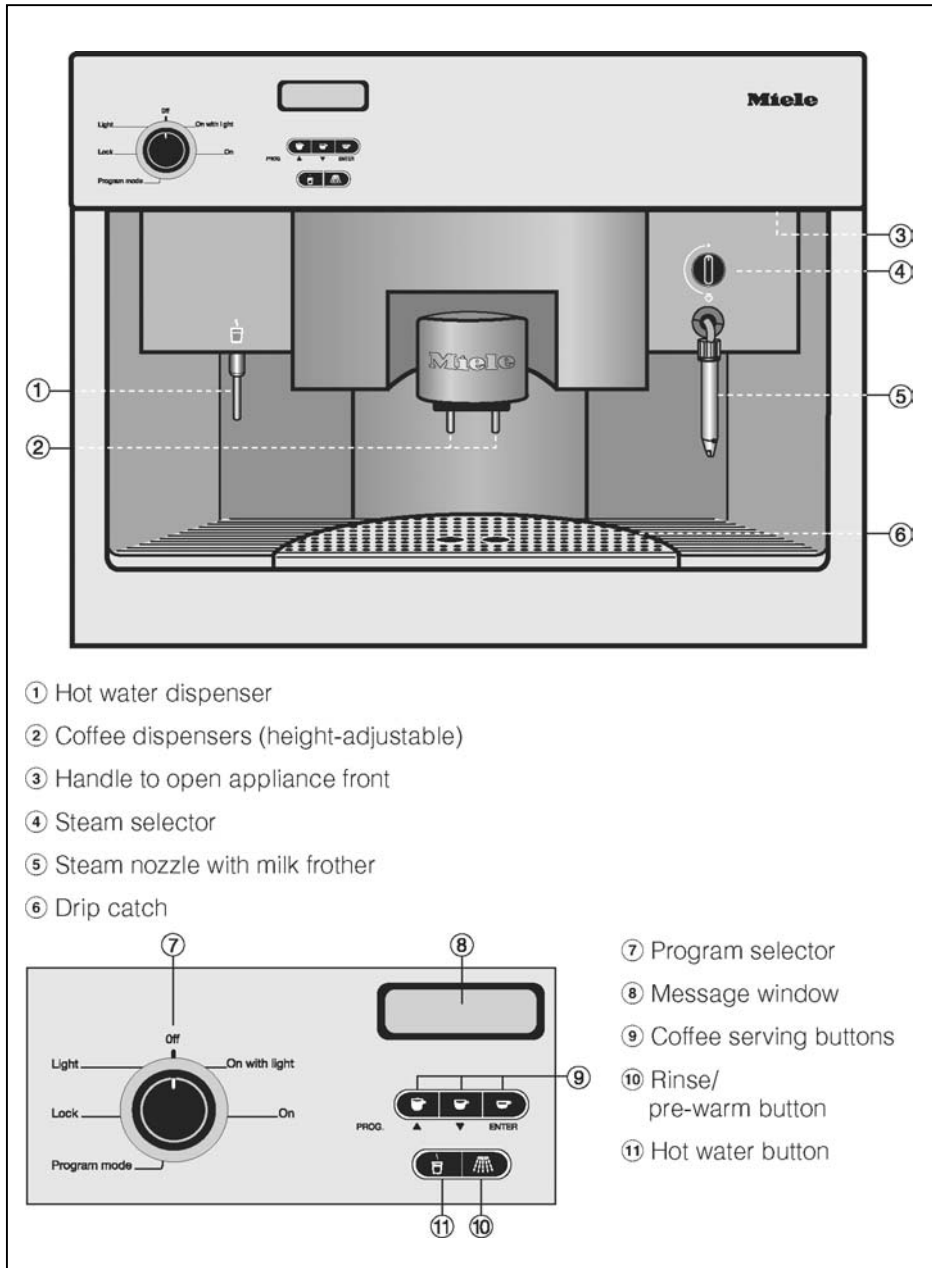

**Figure 1-1:** Appliance Overview (Front & Controls)

## Technical Information

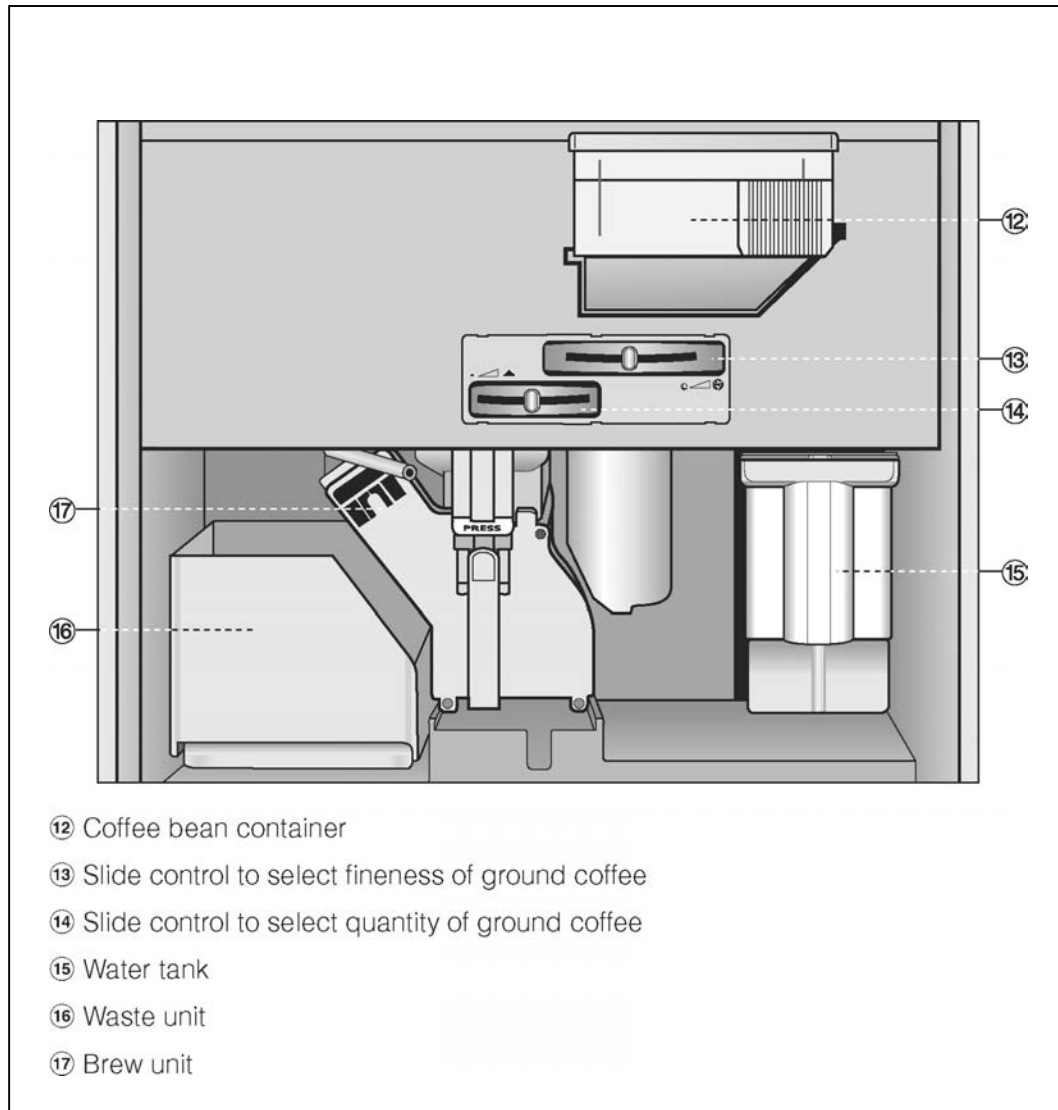
**Figure 1-2:** Appliance Overview (Interior)

## 1.2 Technical Data

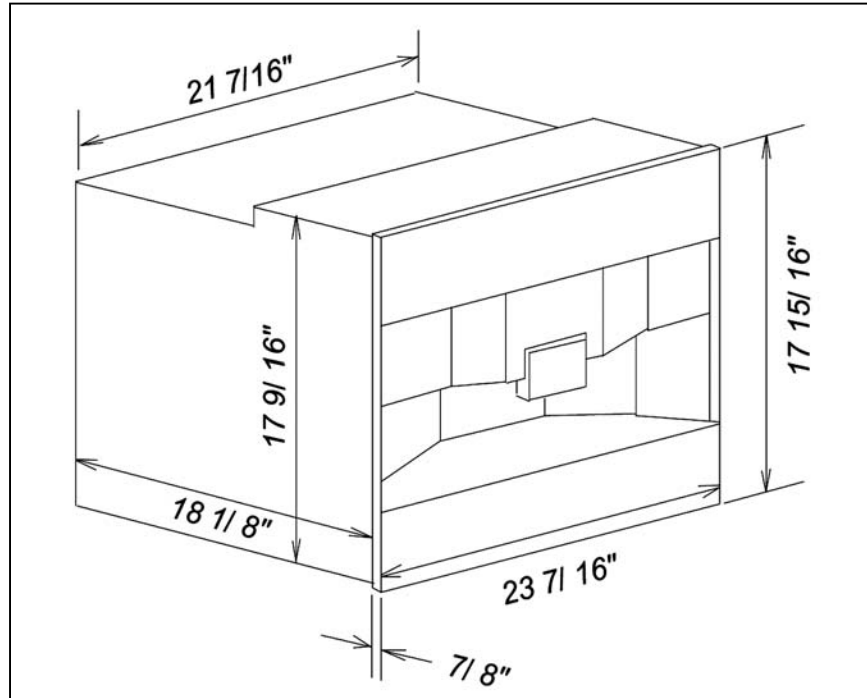

Figure 1-3: CVA610 Product Dimensions

### Electrical Information

The CVA610 Coffee System is equipped with a power cord and a molded NEMA 6-15P plug for connection to a 240 (208) V, 15 A, 60 Hz NEMA 6-15R (receptacle).

Technical Information

## 1.3 Layout of Components

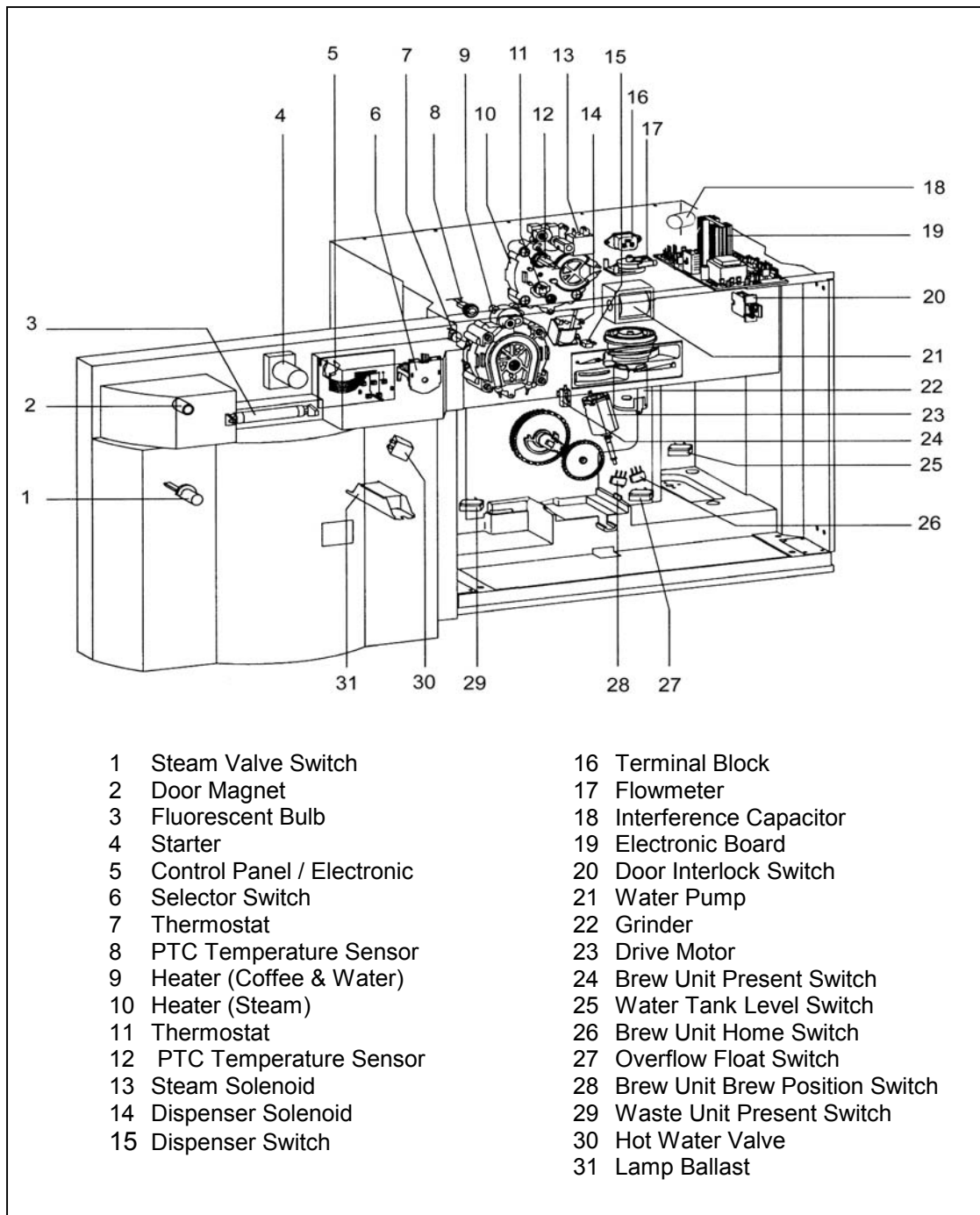

**Figure 1-4:** Overview of Components

Technical Information



## 2.0 Installation

 Make sure power is not supplied to the appliance while installation or maintenance work is performed.

Disconnect the power supply to the work area by unplugging the unit, tripping the circuit breaker or removing the fuse.

The coffee system must be installed into cabinetry before being operated.

- Plug the appliance into the electrical outlet.
- Push it all the way back into the cabinet, until there is a resistance.
- Open the front of the machine and partially tighten the screws.

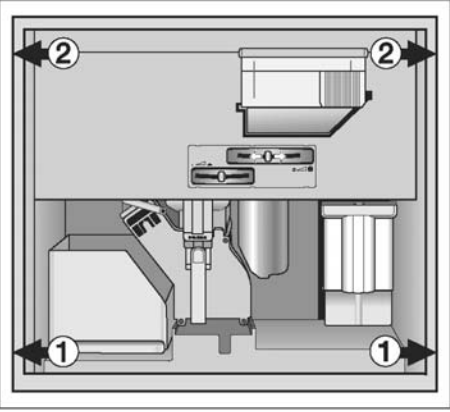

- Carefully turn the lower screws, ①, to center the machine in the cabinet.
- To secure the appliance in the cabinet, tighten the upper screws, ②, carefully by hand. Do not use an electric screwdriver.

**Figure 2-1:** Installation Information

**Note**

For further information, refer to the installation section of the Operating Manual -OR- the Miele installation Manual.

Technical Information

### 3. Commission and Operation

#### 3.1 General Operation

##### 3.1.1 Preparing Coffee

1. Place a cup under **both** coffee dispensers.

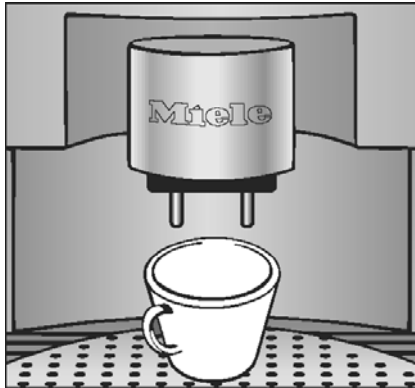

Figure 3-1: Coffee cup placed under both dispensers.

2. Press the desired coffee button once.



Figure 3-2: Pressing the coffee button

The coffee will be prepared.

The following message will appear in the message window, depending on the button pressed:



Figure 3-3: Displayed Message While Dispensing

## Technical Information

**3.1.2 Canceling the Preparation**

Press one of the coffee buttons to stop preparation immediately.



**Figure 3-4:** Canceling the preparation

**3.1.3 Steam Control**

- Turn the steam ON by turning the steam selector counter-clockwise.
- Turn the steam OFF by turning the steam selector clockwise.

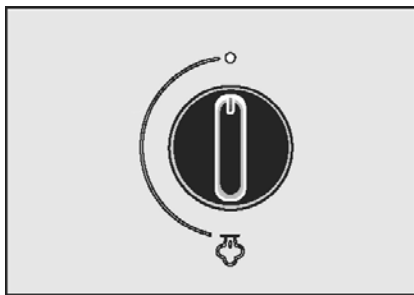

**Figure 3-5:** Steam Control

### 3.1.4 Hot Water Dispensing

1. Place a cup under the hot water dispenser.

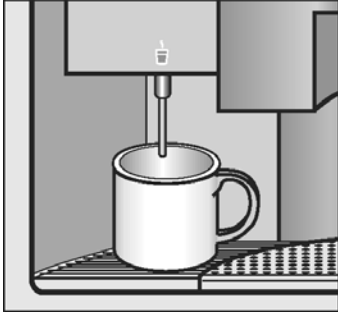

Figure 3-6: Cup placed under hot water dispenser

2. Press the hot water button. Hot water will be dispensed.
3. Press the hot water button again to stop the hot water flow.



Figure 3-7: Hot water button

#### **Service Tip**

The hot water dispensing stops automatically if...  
a specific volume (cup size) is programmed  
and  
the "Programmed Hot Water" feature is activated.

## Technical Information

**3.1.5 Adjusting the Coffee Grinder**

Controls:

- to the left for finer grinding
- to the right for coarser grinding.

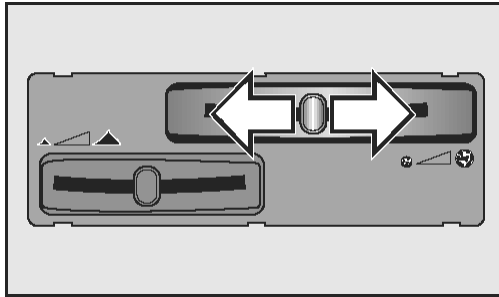

**Figure 3-8** Grinder Adjustment Controls

- If the coffee flows too quickly, the beans have been ground too coarsely. Adjust the grinder to a finer setting.
- If the coffee trickles, the beans have been ground too finer. Adjust the grinder to a coarser setting.

**Note**

- You should be able to feel the notches when moving the slide control.
- If the slide control will not move:  
Close the machine and dispense a cup of coffee. Then try to move the slide control again.

### 3.1.6 Filling the Coffee Bean Container

1. Carefully pull the container outward until the lid is visible.
2. Lift the lid (as shown in figure 3-9).
3. Fill the container with coffee beans to about 1" from the top.
4. Close the lid and push the container back into place.
5. Shut the appliance door.

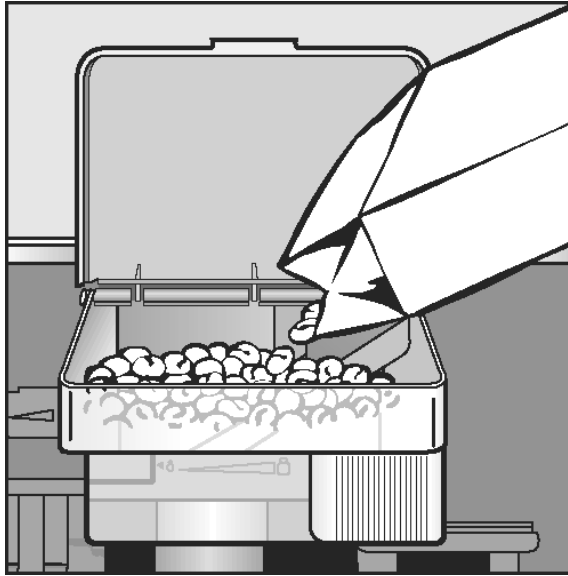

**Figure 3-9** Filling the Coffee Bean Container

#### **Important**

Only put pure espresso or coffee bean in the container. Anything else, including ground coffee, hot cocoa, instant coffee, or treated coffee beans (flavorings, caramel, or sugar) will damage the grinder.

#### **Service Tip**

Always remove all coffee beans before attempting to remove the bean container. Failure to do so will result in the beans spilling out! Refer to 5.37 for additional information.

## Technical Information

**3.1.7 Filling the Water Tank**

The Water Tank must be cleaned and filled with fresh water before each day of use. A reminder will appear in the message window when the unit is first turned on.

1. Open the front of the machine.
2. Lift the water tank up and out of the appliance.
3. Open the lid and fill the container with cold drinking water to within about 1" (2 cm) of the top.

**Important**

Never add hot water or any other liquids to the water tank.

4. Close the lid and place the tank in the machine, pushing it straight back. Ensure the tank is fully seated into position.



## 4.0 Description of Function

### 4.1 Door Switch (S24)

The Door Switch interrupts the main power circuit when the door is opened.

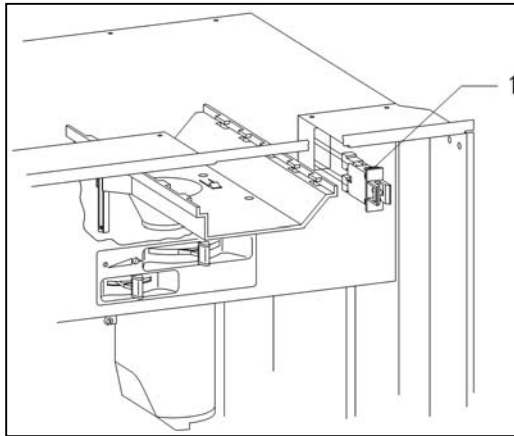

Figure 4-1: Door Contact Switch (S24)

### 4.2 Overflow Switch (B8/3)

The Overflow Switch is mounted to the bottom of the casing. The associated float (with internal magnet) is located within the drip tray. Should a leak develop, water flows into the drip tray. The float rises and the Overflow Switch becomes actuated. The electronic then displays the “Watersystem Fault” message.

## Technical Information

**4.3 Brew Unit – Home Position**

Refer to figure 4-2. The brew unit must be in the “home position” before it can be removed from the appliance.

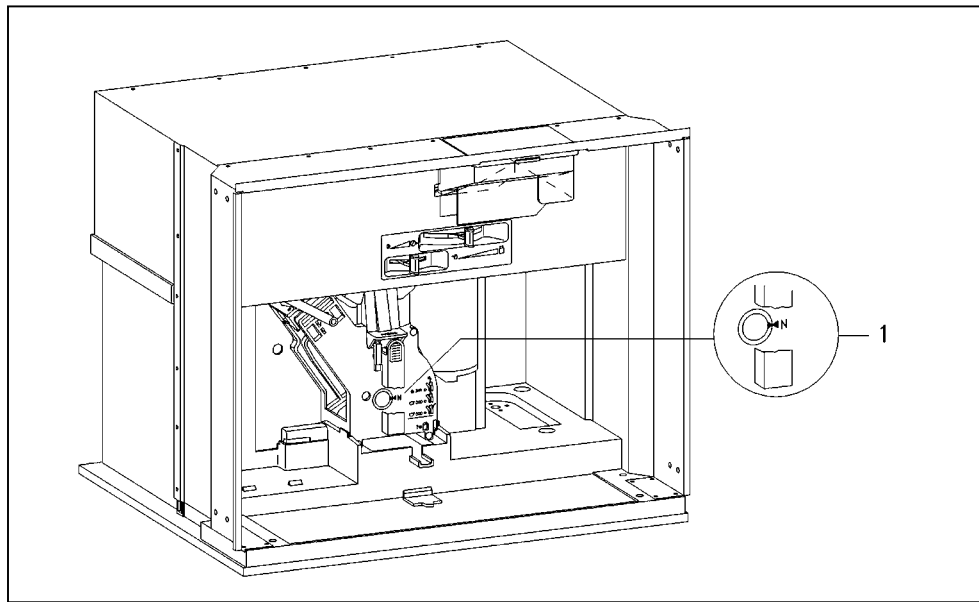

Fig. 4-2: Brew Unit in the “home” position

#### 4.4 Brew Unit – Drive and Water Connections

Refer to figure 4-3.

When the Brew Unit is installed, it locks into position. The Locking Mechanism Switch Lug (item 3), activates the Brew Unit Present Switch (item 4). The Drive Shaft (item 6), engages with the Drive Shaft Socket (item 1) to provide drive to the Brew Unit.

When the Brew Unit moves into the “Brewing Position” the Hot Water / Water Connection Socket (item 2) connects to the Nozzle on the Hot Water / Coffee Heater (item 5).

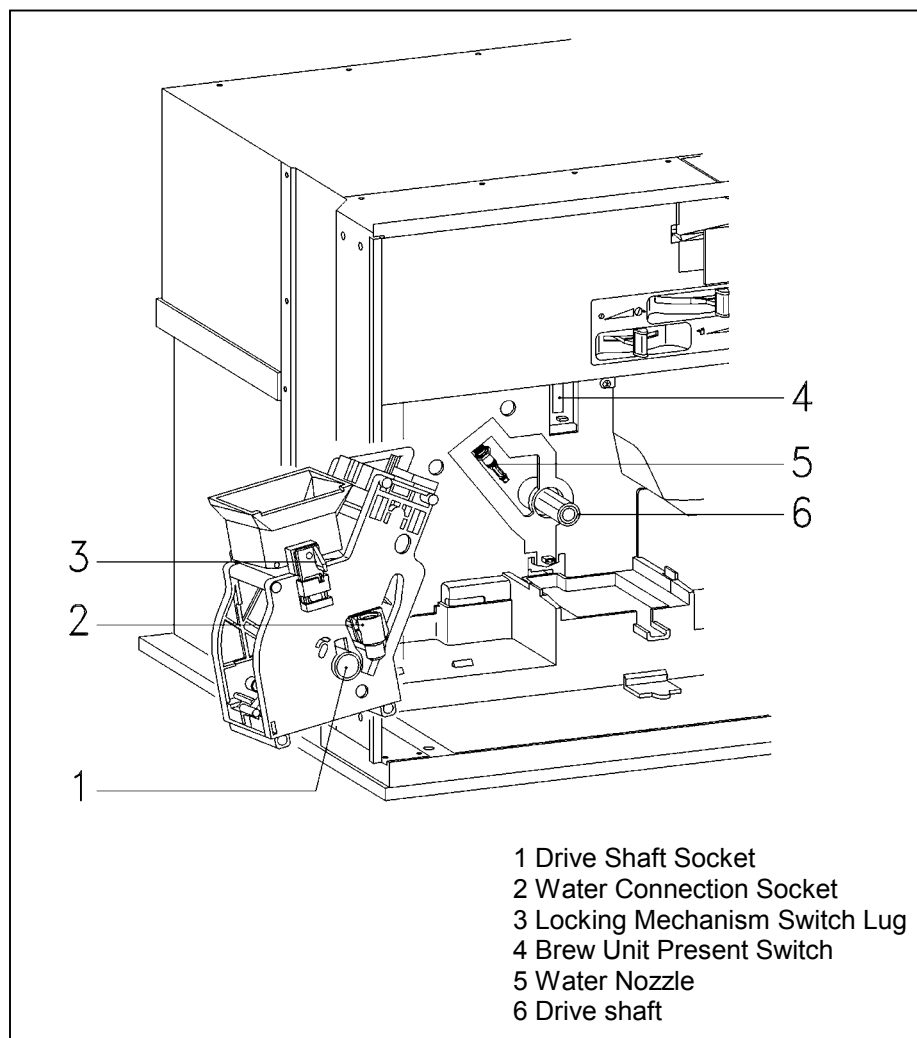
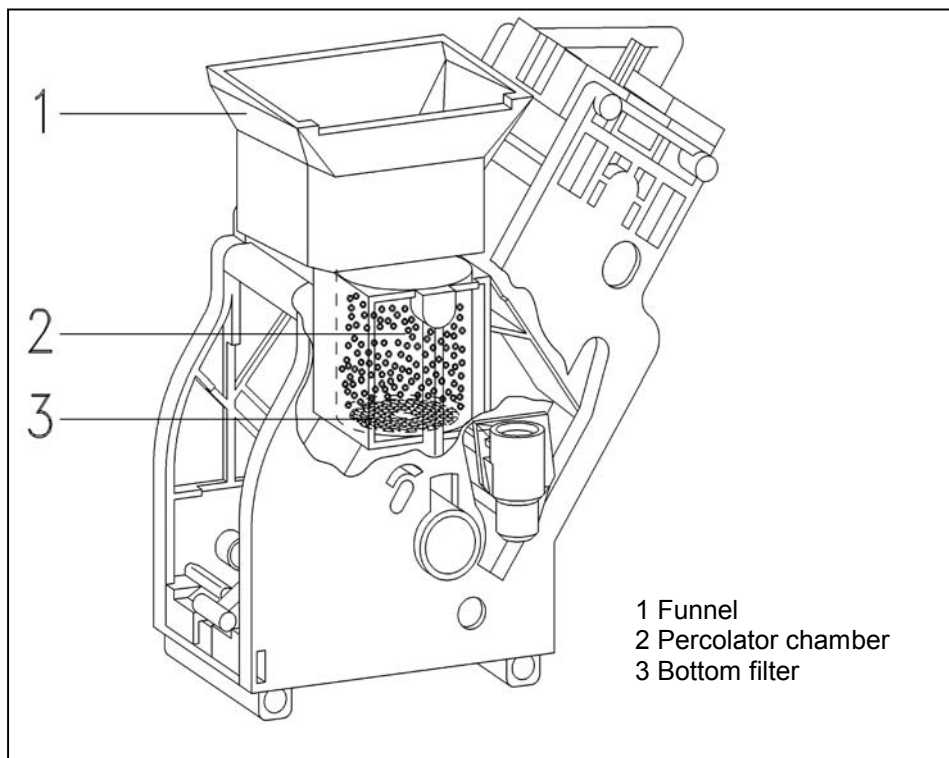

**Figure 4-3:** Brew Unit drive connections

## Technical Information

**4.5 Brewing Procedure**

1. The output of the Grinder provides ground coffee to the Dispenser Housing; until it filled (as determined by the dispenser switch).
2. The Grinder is then powered off by the Electronic.
3. The Dispenser Flap opens twice (two clicks can be heard) via the Dispenser Solenoid.
4. The ground coffee falls into the Brew Unit (via the funnel).

**Figure 4-4:** Brew Unit Filters

Refer to figure 4-5

5. The Brew Unit Drives move the Brew Unit into the “Brewing Position” (as determined by the Brew Position Switch). The grounds are compressed between the top filter (item 2) and bottom filter (item 5).
6. The Water Pump is energized to pump the water through the Hot Water / Coffee Nozzle and into the Brew Unit via the Water Connection Socket (item 4). The hot water forces through the brew unit and the compressed grounds (Pos 3) and exits the top of brew unit via the drain spout (item 1).

With the door of the appliance closed, the drain spout makes contact with the dispensing system on the front of the appliance. The users cup is filled with coffee, as the coffee flow exits.

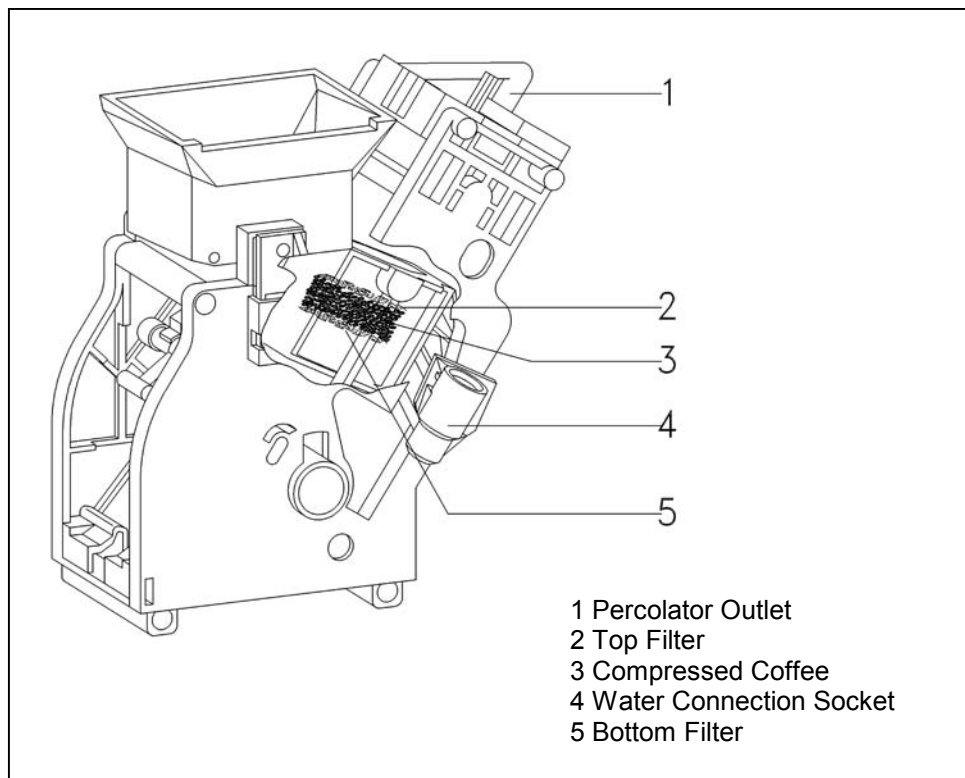
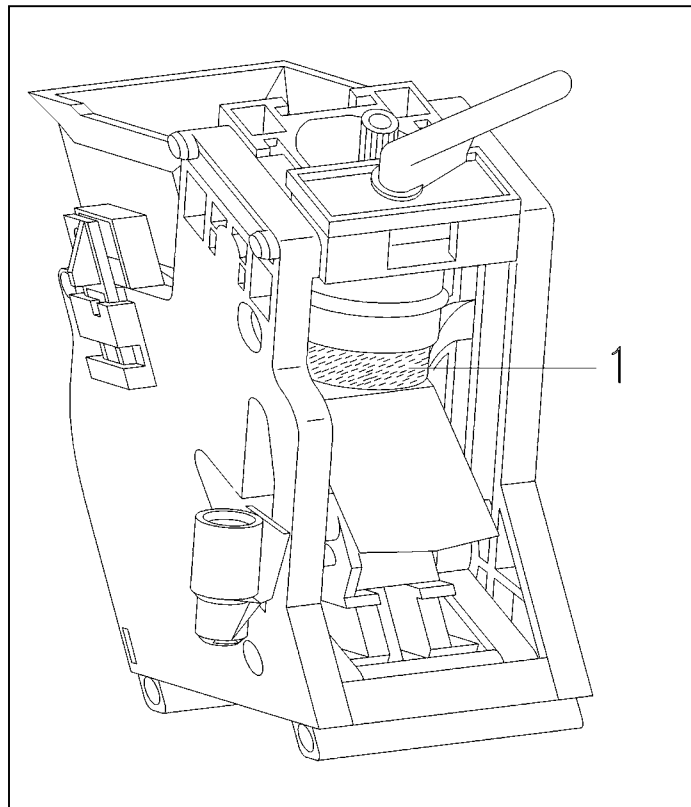

**Figure 4-5:** Brew Unit components.

## Technical Information

Refer to figure 4-6...

7. The drives are energized (in reverse) and move the Brew Unit toward the “home position” position. As this action occurs the coffee chamber moves upward and releases the used compressed coffee grounds. (item1).
8. The drives continue, returning the Brew Unit to the “home position” (as determined by the Home Position Switch.



**Figure 4-6:** Brew Unit, showing compressed coffee “puck”.

#### 4.6 Waste Unit

After coffee has been prepared, the compressed coffee grounds “puck” falls into the Waste Unit. The electronic monitors the number of the compressed “pucks”, until a specific value is reached. The electronic then displays the “Empty Waste Unit” message to the user.

#### 4.7 Waste Unit Present Switch

The Waste Unit Present Switch is mounted to the bottom of the CVA610 housing (behind the area of the Waste Unit) – as shown in the figure 4-7.

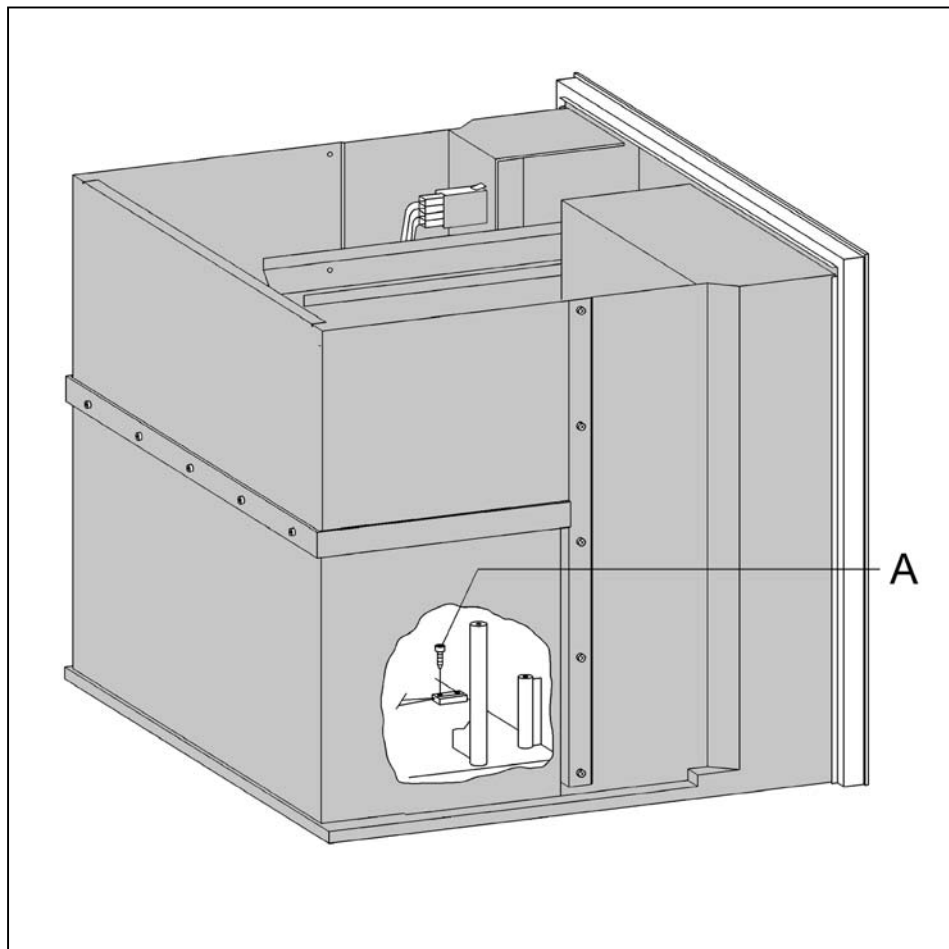
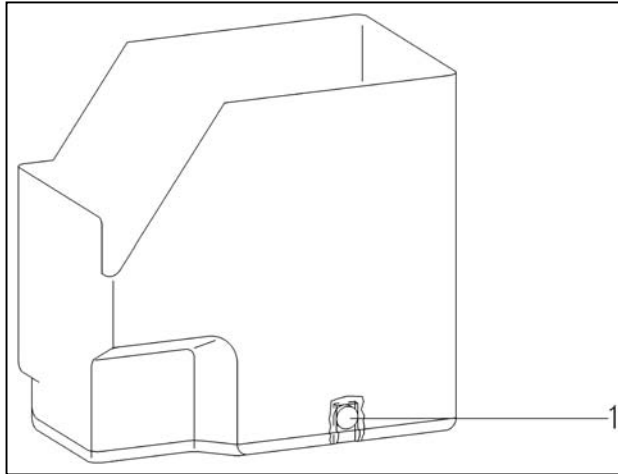

Figure 4-7: Waste Unit Present Switch.

## Technical Information

The actuating magnet (Figure 4-8, item 1) for the Waste Unit Present Switch is located at the bottom edge of the Waste Unit.



**Figure 4-8:** Waste Unit. (1) Magnet for Waste Unit Present Switch.

**Note**

On newer manufactured Waste Units, an additional magnet is present to keep the waste unit attached to the metal frame inside the appliance. The magnet for the Waste Unit Present Switch remains in the same location.



## 4.8 Water Tank

Refer to the figure 4-9.

The Water Tank holds the water for the coffee, hot water and steam. When the water tank is fitted in position, the sealing ring presses upward so water cannot leak.

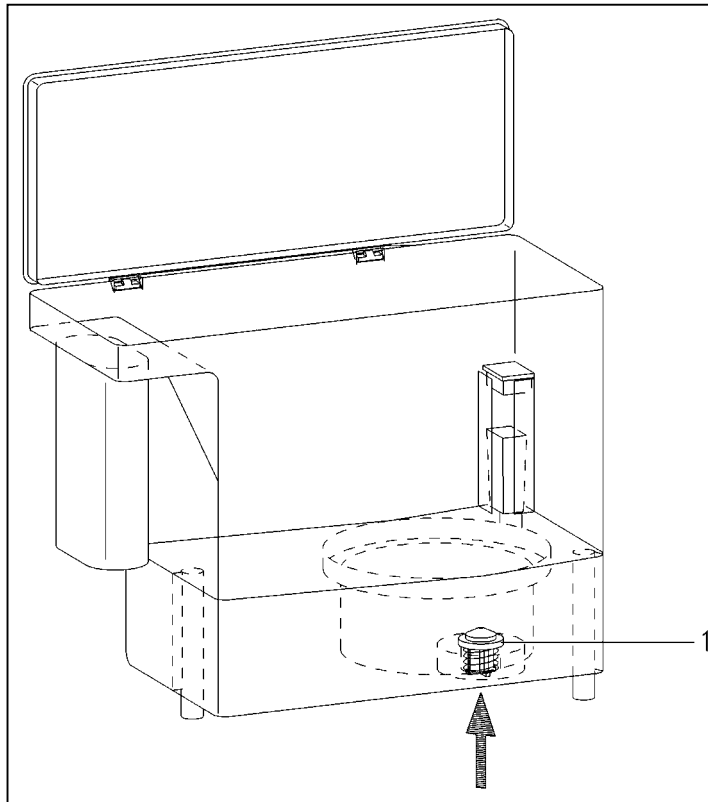
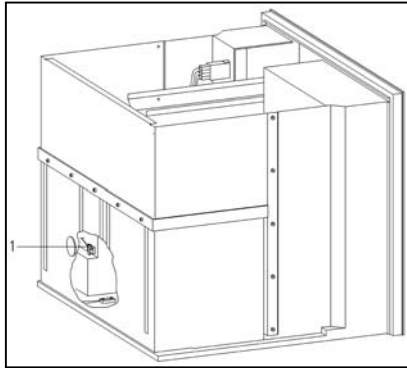

**Figure 4-9:** Water Tank (1) Valve Assembly.

When the Water Tank is removed from the appliance; a spring forces the sealing ring into a position so water cannot flow from the tank.

## 4.9 Water Level Switch

The Water Level Switch is located within the housing, in the area behind the Water Tank Cavity (as shown in figure 4-10).



**Figure 4-10:** Water Level Switch

The Actuating Magnet for the Water Level Switch is located within the float. The float is then installed into the Water Tank (as shown in figure 11, item 1).

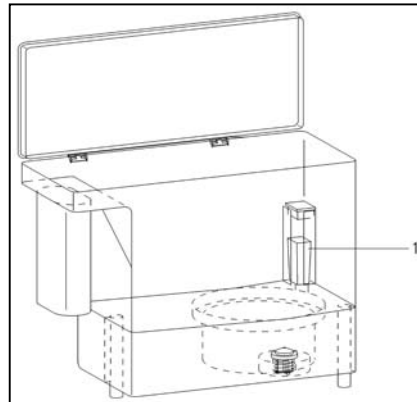

**Figure 4-11:** Water Level Switch Float

With the Water Tank installed and containing at least 900-1000 milliliters of water, the Water Level Switch contacts are closed.

When the water level drops below the minimum quantity, the Water Level Switch contacts open. At this time the quantity incoming water is monitored by the Electronic (via the flowmeter). Once 800 milliliters of water is measured, the “Fill Water Tank” message is displayed.

## 4.10 Grinder Assembly

Refer to figure 4-12.

- The grinding grade depends on the gap between the Grinding Cone (Item 1) and the Grinding Ring (Item 2).
- The gap is set via the Adjustment Lever, (Item 5) on the Adjustment Ring (Item 3). The smaller the gap, the finer the grind of coffee will be.

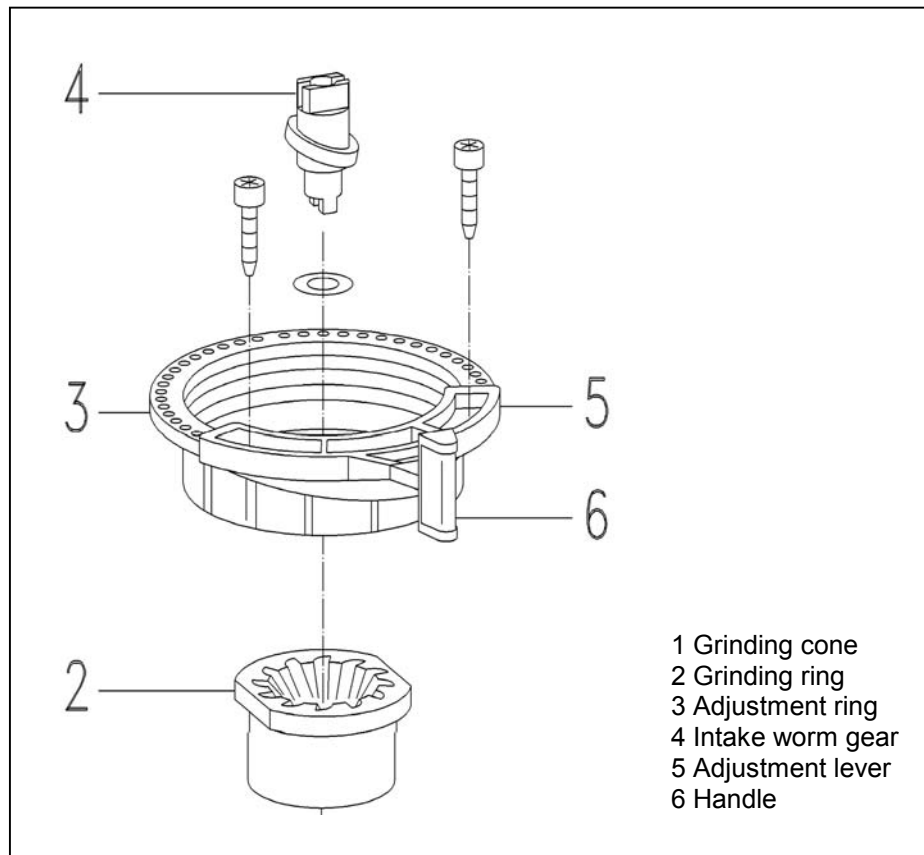

Figure 4-12: Grinder Assembly

### **Warning!**

To avoid binding the grinder, adjustments should be made in small steps.

## 4.11 Grinder - Overload Protection

Should the grinder become blocked by a foreign object (i.e. stone / pebble), the slip coupling interrupts the drive between the motor and the grinder.

Refer to figure 4-13...

The Grinder Motor (item 1) drives the Mounting (item 3) via the Carriers (item 2). This rotary force transfers through the Balls, (item 5) to the Grinder Cone (Item 6).

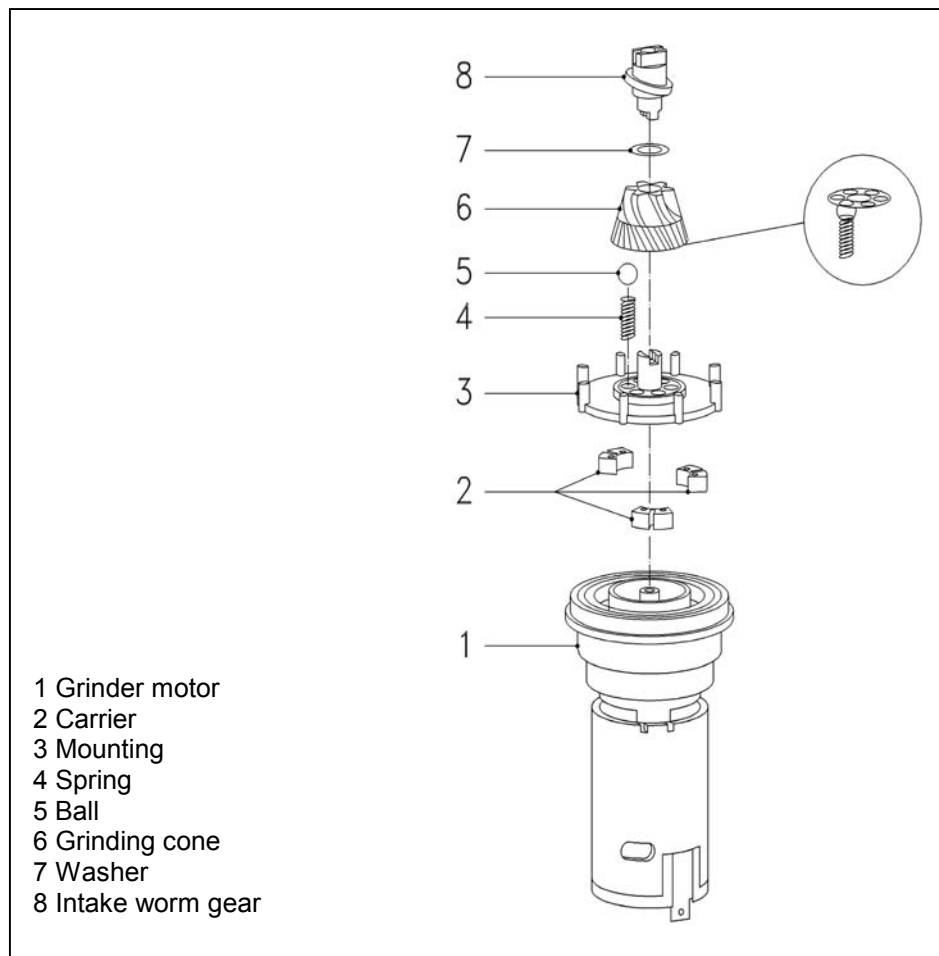

**Figure 4-13:** Components of the Grinder Overload Protection

Should the grinder cone become blocked, the Balls get pressed into the Mounting (as shown below in figure 4-14, Item C) resulting in the drive force being interrupted.

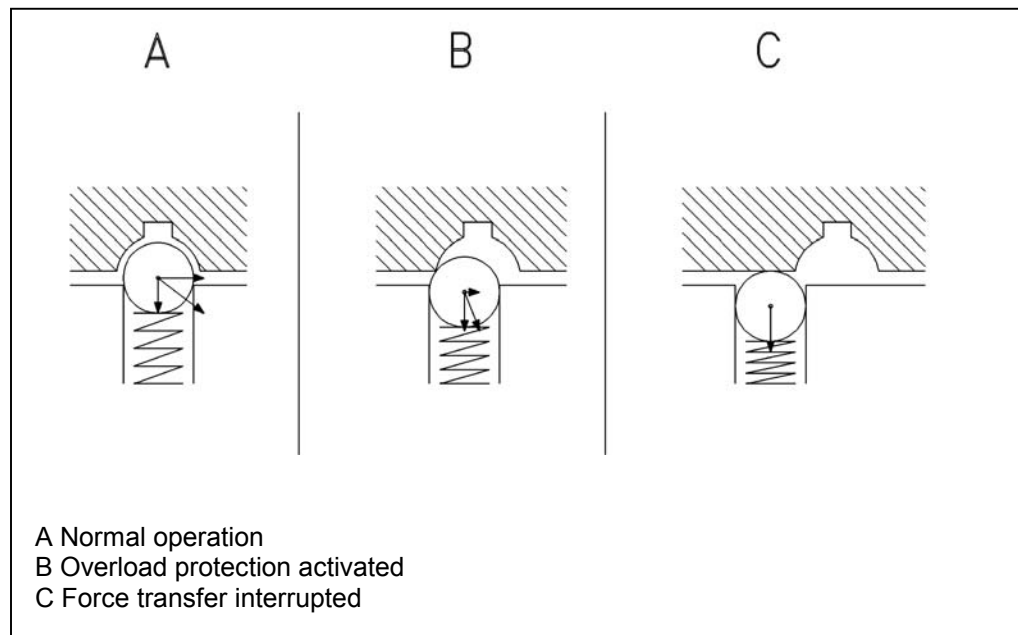

**Figure 4-14:** Grinder cone ball positions under various operating conditions.

## Technical Information

**4.12 Ground Coffee - Dispensing**

Refer to figure 4-15.

By adjusting the Dispenser Lever (item 1), the position of the Dispensing Switch (item 2) is modified. The change results in change to the volume of the dispenser container; hence the quantity of ground coffee changes. Each position along the setting alters the coffee quantity by about 0.5 grams.

The grinder fills the dispenser container with ground coffee. When the dispenser container is full, the Dispenser Switch is activated and the grinder motor is switched off.

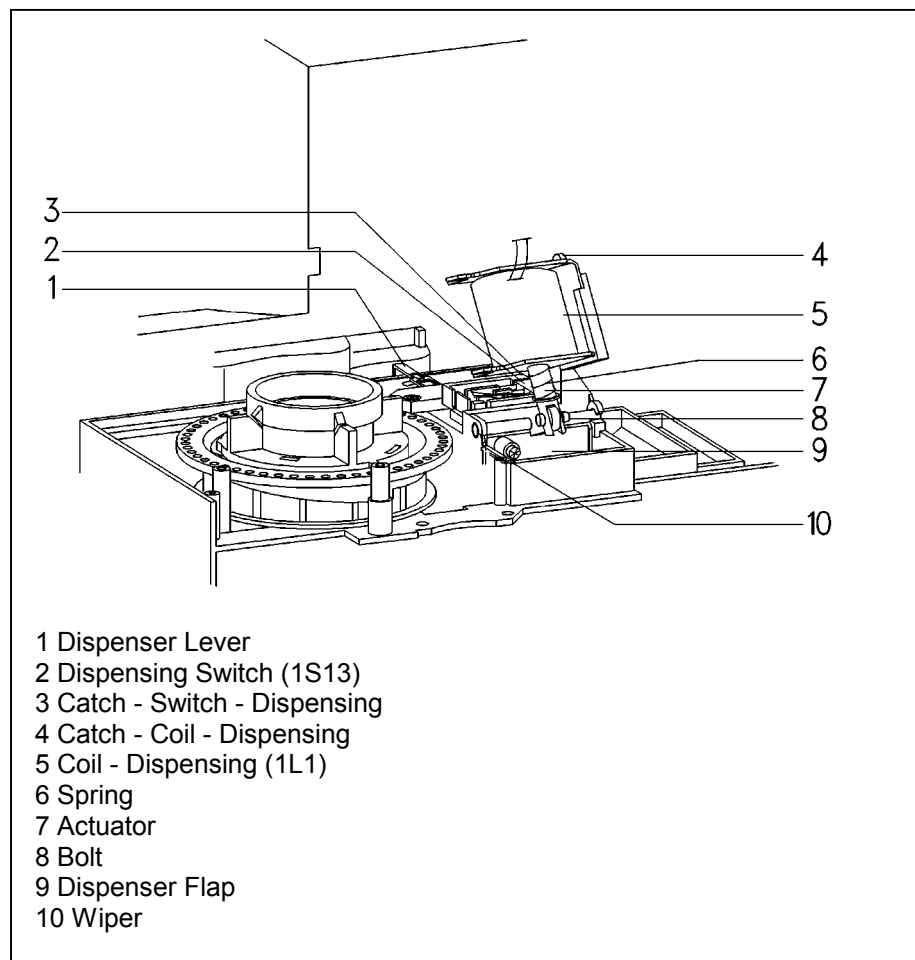

**Figure 4-15:** Coffee Dispensing Components

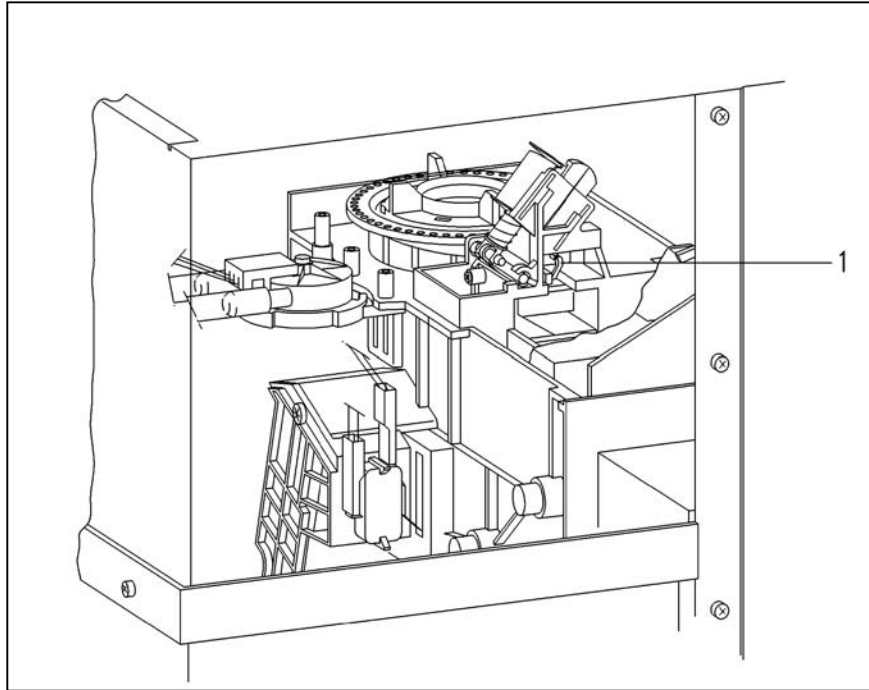

**Figure 4-16:** Dispensing Lever

The dispensing solenoid is activated twice by the electronic. During the initial activation the ground coffee drops into the brew unit. The second activation is to ensure no loose grounds block the channel, as the wiper passes and loosens any ground coffee residues.

If the dispenser container is not filled (i.e. no coffee beans) the Dispenser Switch is not activated and the “Fill Coffee Beans” message is displayed.

## Technical Information

**4.13 Brew Unit Drives**

Refer to figure 4-17...

The Brew Unit locks into position against the Drives Mounting Plate. The locking mechanism Switch Lug (Item 3) activates the Brew Unit Present Switch (Item 4). The Drive Shaft, (Item 6) engages with the Percolator Drive Shaft Socket,

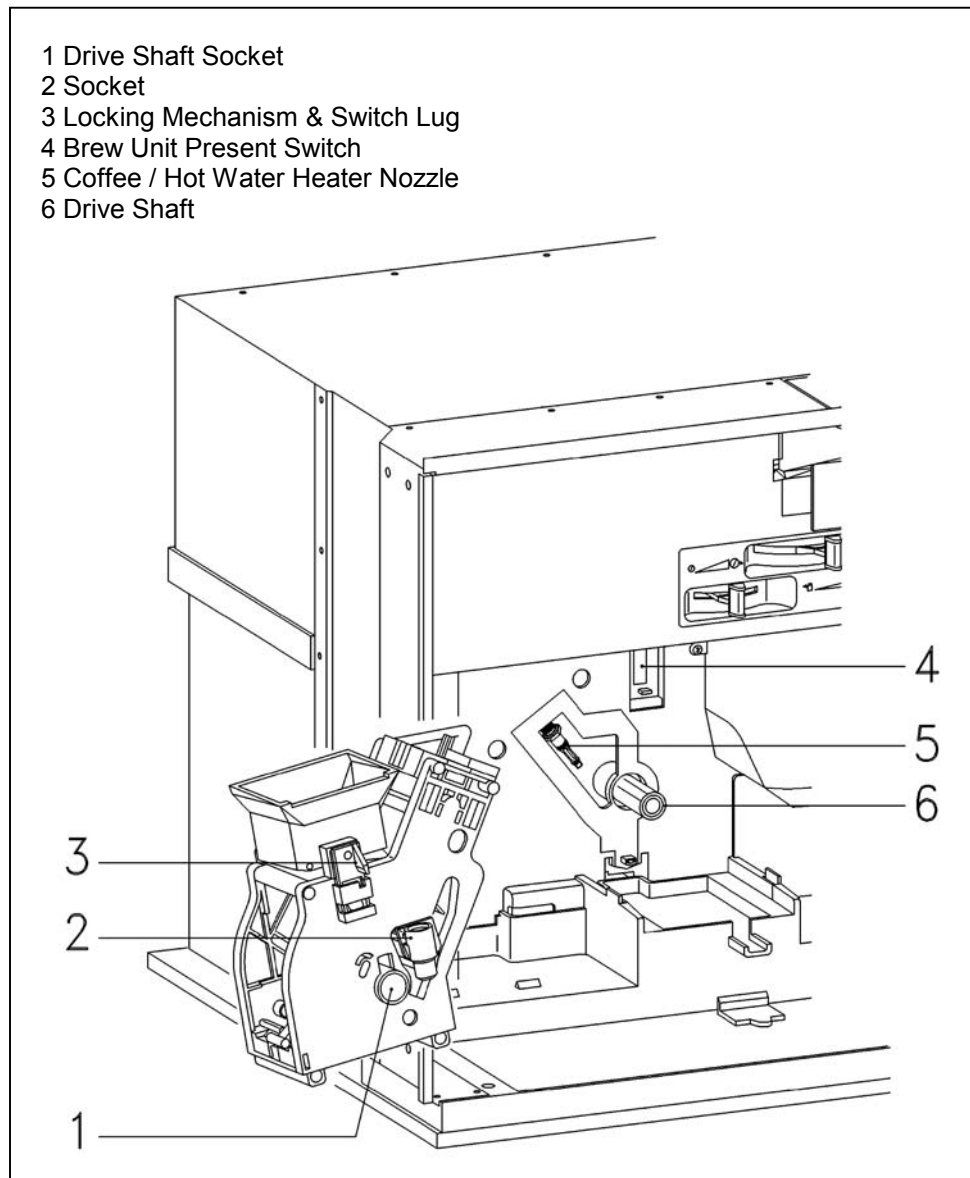
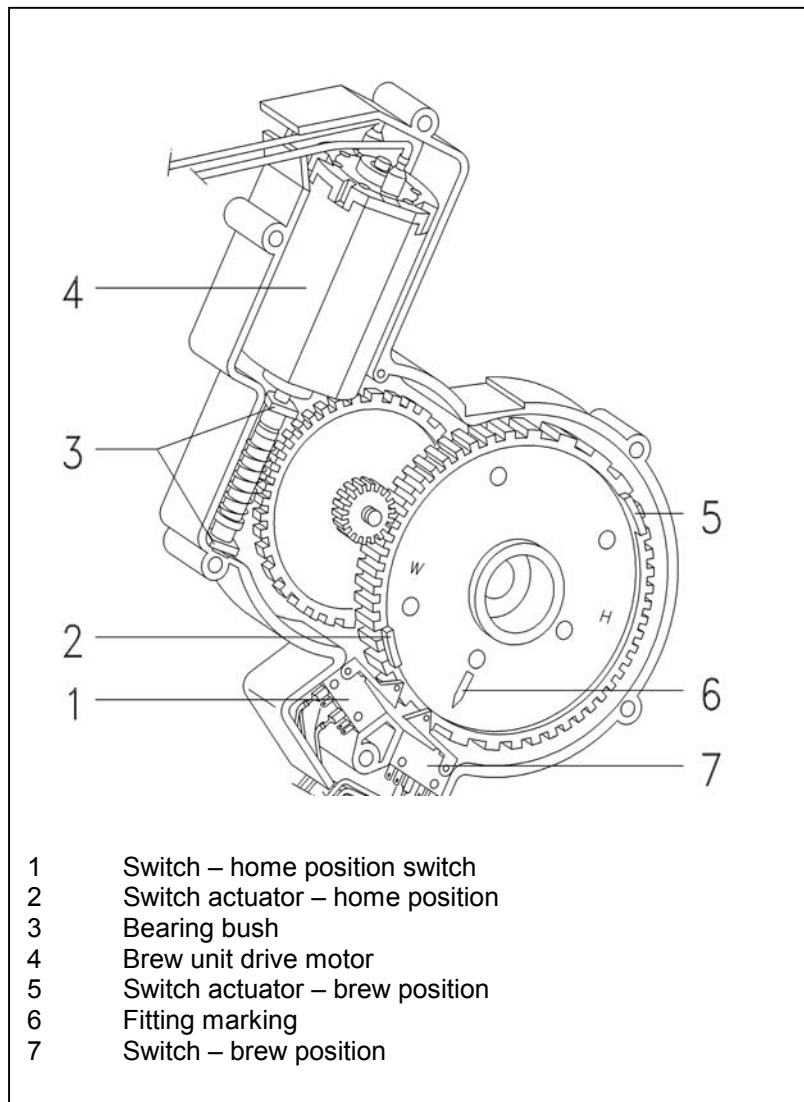

Figure 4-17: Components of the Brew Unit Drive Assembly.



Refer to figure 5-18.

The Drive Motor (Item 4) powers the Worm Gear (Item 3). The drive action is transferred to the Step-down Gear and then the Drive Gear. The center of the Drive Gear contains the Drive Shaft that connects to the Brew Unit Drive Shaft Socket. The drive gear The drive shaft cog wheel has two switch actuators, (Items 2 & 5) for the limit switches for the brew position and home position. The electronic unit registers the brew position and the home position via the limit switches, (Items 1 and 7).



**Figure 4-18:** Brew Unit Drive Assembly

## Technical Information

**4.14 Water Pump**

The pump is self-priming and can develop a pressure of up to approx. 16 bar. For espresso preparation a pressure of approx. 8 bar is required so that the water can be forced through the compressed ground coffee. A further increase in pressure does not improve beverage quality.

The pump is fitted with a safety valve which opens at 16 bar system pressure. If pressure is too high, water is passed from the safety valve via a hose to the fitting plate and from there to the housing under the percolator unit. The water is then passed through the door rear panel to the drip tray.

The pump is connected in series with a temperature limiter. The temperature limiter switches off the pump if a high temperature is developed.

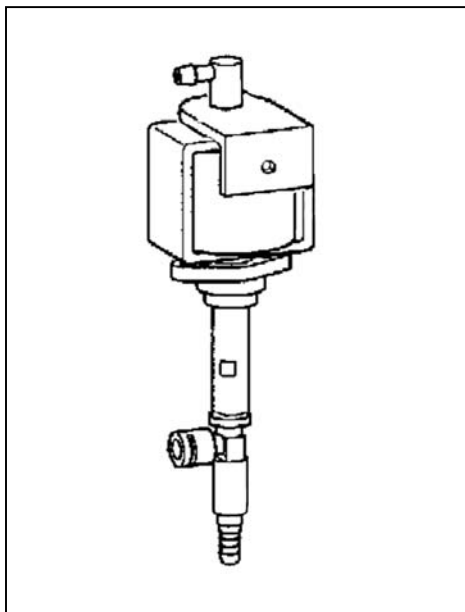

Figure 4-19: Water Pump

#### **4.15 Flow meter**

All water taken from the water container flows through the flow meter. The flow meter passes signals to the electronic unit proportional to the quantity of water passing through it.

The electronic unit then establishes the quantity of water that has flowed and stores the figure. Approx. 300 pulses from the flow meter indicate a flow of 100 ml water.

The electronic unit controls the required water quantity for beverage preparation and ensures that it remains constant. The service mode can be used to check the proper operation of the flow meter.

#### **4.16 Heater - Data**

##### **Coffee / Hot Water Heater 1R1 & 1R2**

Voltage 220(240) V

Power rating 1090 W / 437 W

##### **Steam Heater 2R1**

Voltage 220(240) V

Power rating 1100 W

## Technical Information

## 4.17 Heaters

Refer to the figure 4-20...

The Coffee / Hot Water consist of a large heater element (Item 1) and a smaller heater element (item 7). The Steam Heater has consist of one heater element (figure 4-21, Item 3).

Each Heater uses a temperature sensor (Item 5) that provides signals to the Electronic to monitor the temperature ; and control the cycling (switching) of the Heater Element(s).

Additionally, each Heater assembly is equipped with a Temperature Monitor (Item 3) connected electrically in series with the element. Should the temperature become excessive, the device electrically interrupts the power to the heater element.

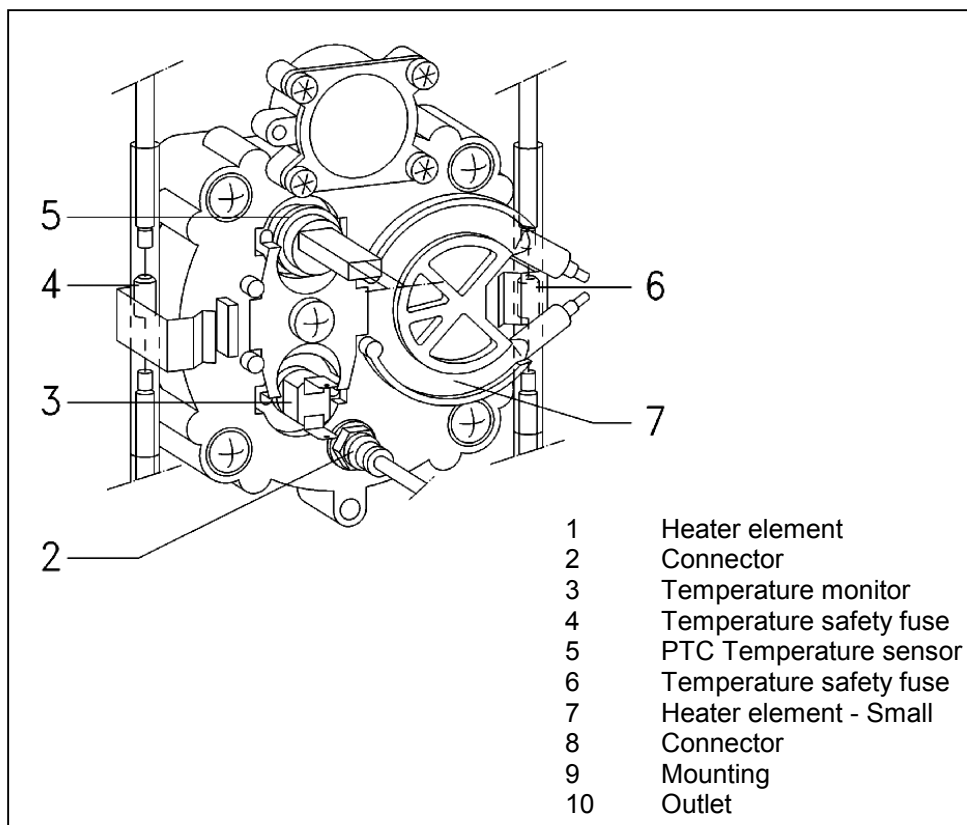
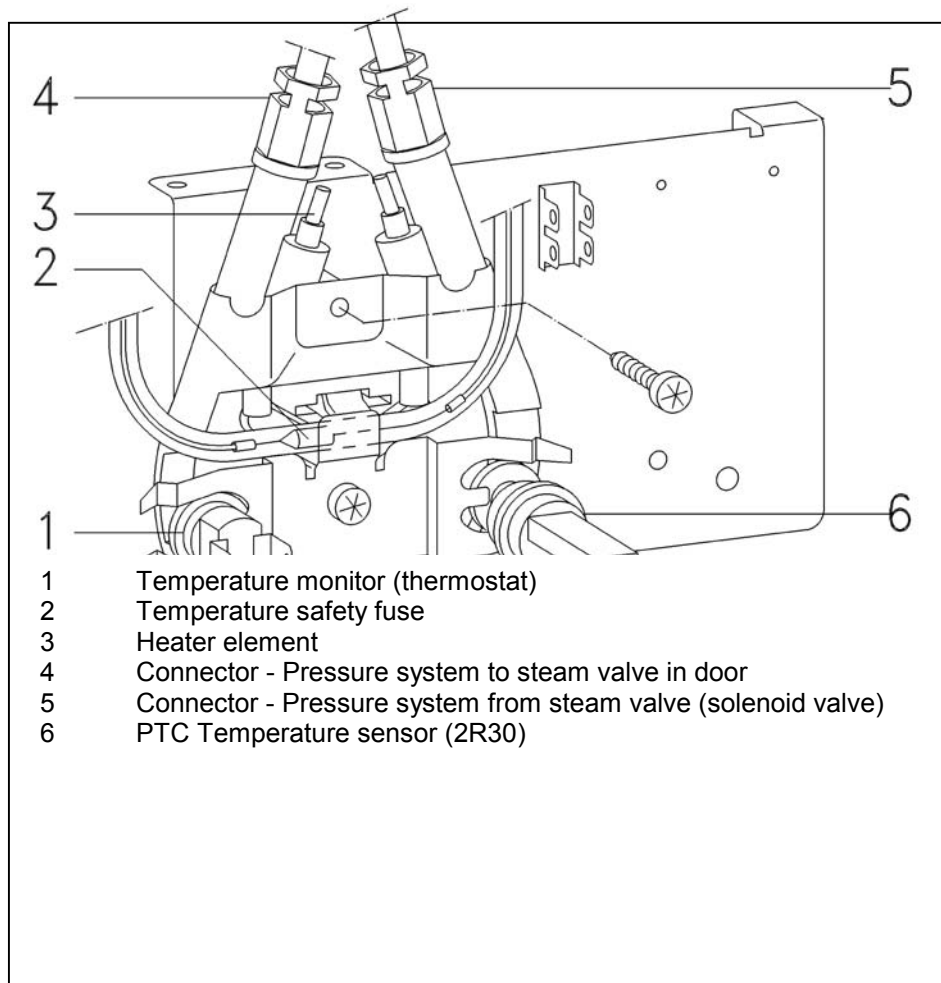

Figure 4-20: Hot Water / Coffee Heater (1R1 and 1R2)

The heating circuit also contains a Temperature Activated Safety Fuse. Should the temperature exceed a specific threshold due to an operating fault, the fuse blows and interrupts power to the element(s).

Should this fuse be blown, the cause must be located and resolved before replacing the fuse.

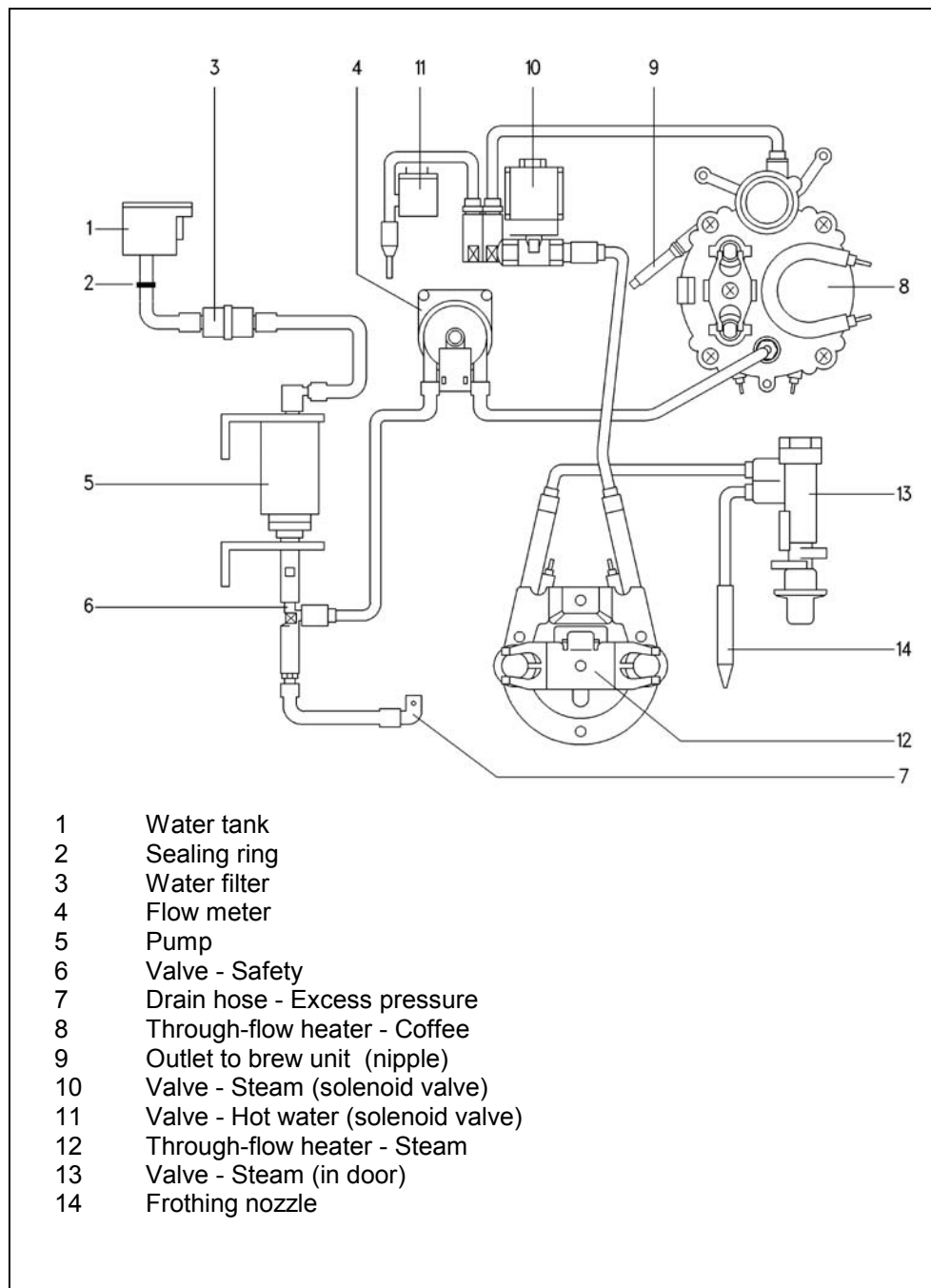

**Figure 4-21:** Steam Heater (2R1)

**4.18 Water Path****Figure 4-22: Water Path**

**4.18.1 Water Intake**

The Water Pump is responsible for taking in water from the Water Tank. The bottom of the pump contains a safety valve. The valve is designed to open should the system pressure exceed 16 bar (232 psi). A hose is connected to the valve to route the water away from the components.

**4.18.2 Water Path - Coffee**

Water exiting the Water Pump is pumped under pressure through the Flowmeter, through the Coffee / Hot Water Heater and through the Heater Outlet Valve (Nipple) into the Brew Unit. Water passes through the compressed coffee grounds and exits the Brew Unit as coffee. The coffee then flows to the dispenser tubes on the front of the appliance into the user cup.

**4.18.3 Water Path - Hot water**

Water exiting the Water Pump is pumped under pressure through the Flowmeter, through the Coffee Heater and through the Hot Water Valve and Hot Water Outlet.

**4.18.4 Water Path - Steam**

Water flows the same as the hot water system, except the water exiting the Coffee / Hot Water Heater is routed via Steam Solenoid into the Steam Heater. Steam exits the Steam Heater and exits via the Steam Valve and Frothing Nozzle.

**4.18.5 Steam Valve and Steam Valve Switch**

The Steam Valve is a mechanical valve regulated via a knob on the front of the appliance. As the knob is turned counterclockwise the amount of steam exiting the valve increases.

The Steam Valve Switch is mounted to the Steam Valve Bracket. When the Steam Valve is opened, the Steam Valve Switch is actuated.

The switch is monitored by the Electronic and when actuated, the Electronic energizes the Steam Solenoid (routing the exiting water from the Coffee / Hot Water to the Steam Heater).

## Technical Information

**4.19 Heater Outlet Valve (Nipple)**

The Heater Outlet Valve is normally closed. However, during the brewing process the Brew Unit is driven into the "Brew Position and mechanically opens valve. This allows the hot water (under pressure) to flow through the brew unit.

The Heater Outlet Valve uses several o-rings to ensure the connection between the Outlet Valve and the Brew Unit remain air and water tight. This ensures air does not entering the water path and disrupt the proper flow and pressure; and water does leak from the system.

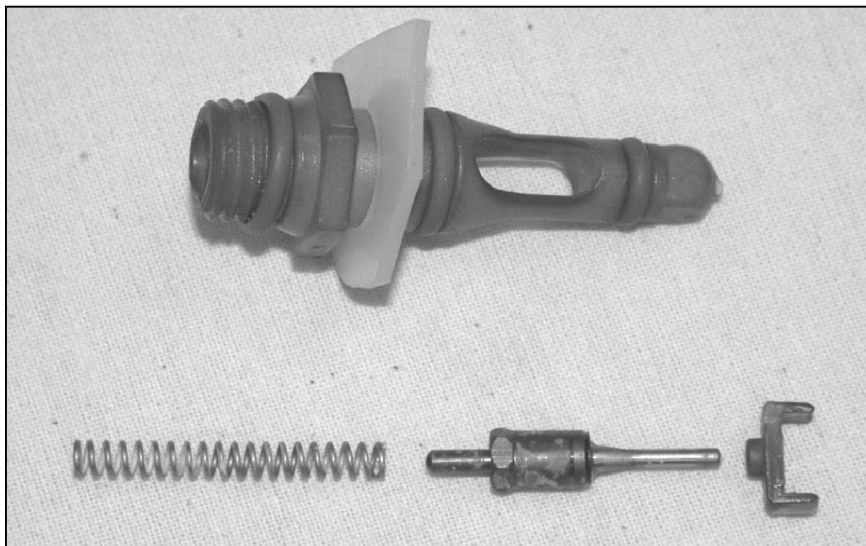

**Figure 4-23:** Heater Drainage (Nipple)

The two o-rings that form the seal to the brew unit can be accessed and replaced from the front / inside area of the appliance - once the brew unit removed.

To access the upper seal or for service on the valve; the Heater Assembly must be removed from the appliance. This permits easy disassembly of the valve for a thorough inspection. Although components of the valve are available separately, it is highly recommended the three components be replaced at one time.



## 4.20 Electronic Assembly

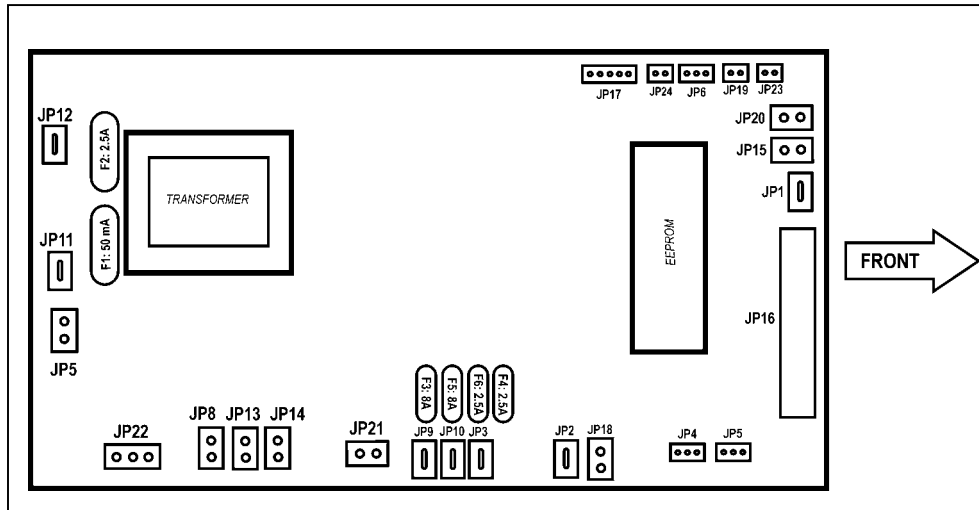

**Figure 4-24:** Preview of Electronic Board Assembly

For further information on the electronic modes  
– refer to section 6 “Fault Diagnosis”

Technical Information

## 5.0 Service and Maintenance

### 5.1 Lid - Removal

1. Remove the lid screws, as shown in Figure 5-1
2. Remove the lid.

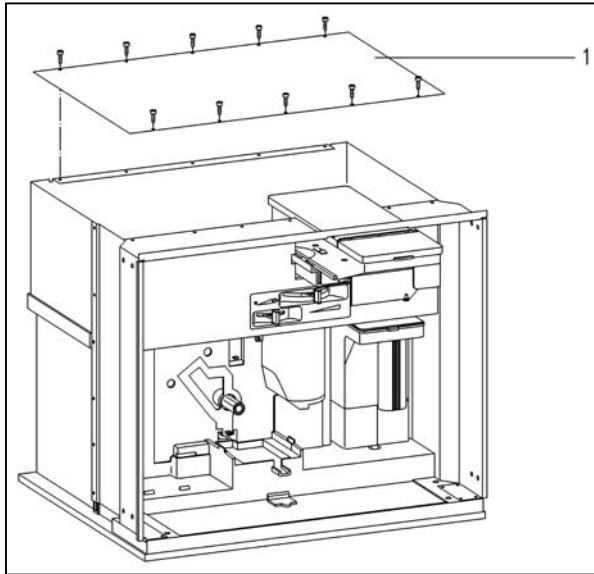

Figure 5-1: Lid and securing screws

### 5.2 Mains Filter (Z1) - Removal

1. Perform: Lid removal (5.1).
2. Remove the mains filter nut (Figure 2 - Item 1).
3. Remove the Filter.
4. Disconnect the mains filter electrical connections

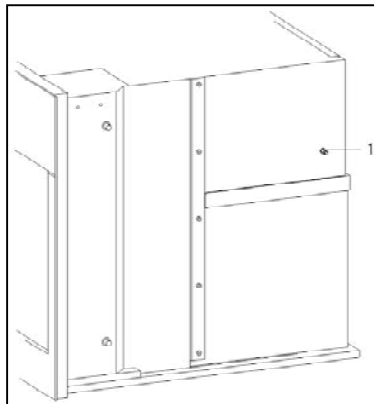
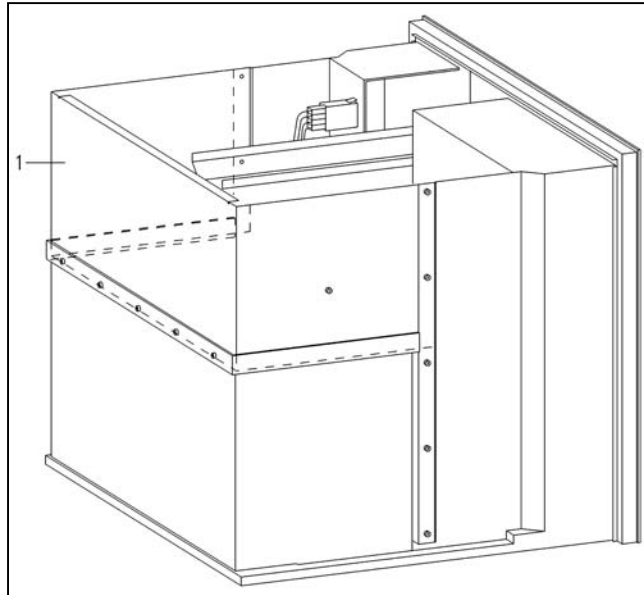

Figure 5-2: Mains Filter (Z1) Mounting Location

## Technical Information

**5.3 Rear Panel - Removal**

1. Remove the lid (5.1).
2. Remove the Mains Filter (5.2).
3. Remove the fixing screws from the rear panel.
4. Disconnect the earth lead from the rear panel.
5. Remove the rear panel upwards.

**Figure 5-3:** Rear Panel Removal

## 5.4 Adjustment Slide Switch Frame - Removal

1. Open the door.
2. Pull off the slide switch knobs.
3. Press the retaining lugs inwards with a small screwdriver (Figure 5-4).
4. Remove the frame.

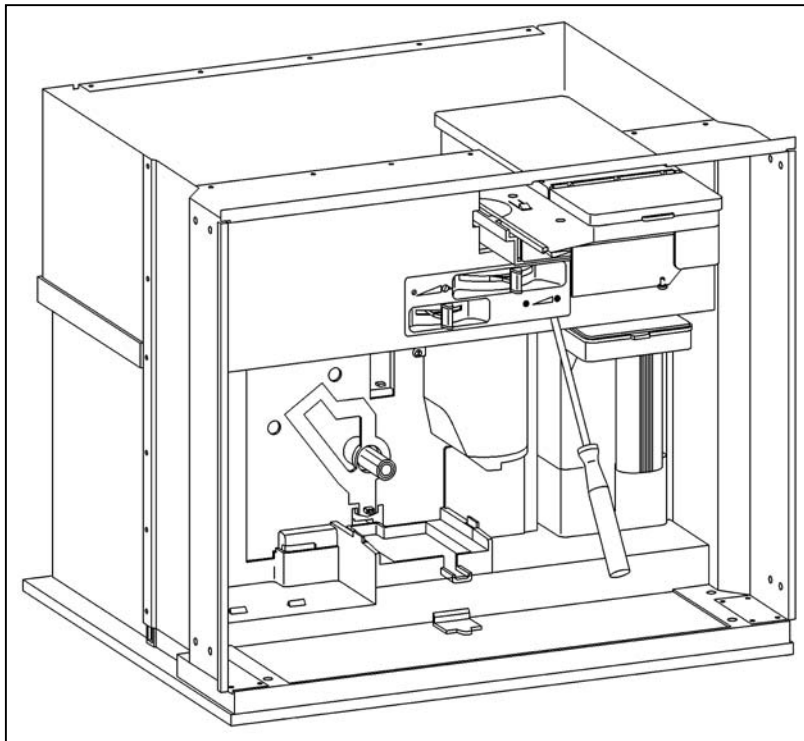

**Figure 5-4:** Removing the Adjustment Slide Switch Frame (Bezel).

## Technical Information

**5.5 Door Contact Switch (S24) - Removal**

Refer to figure 5-5 below...

1. Remove the lid (5.1)
2. Open the door.
3. Disconnect the door switch connections.
4. Press the switch retaining lugs inwards with a small screwdriver.
5. Remove the door switch to the front.

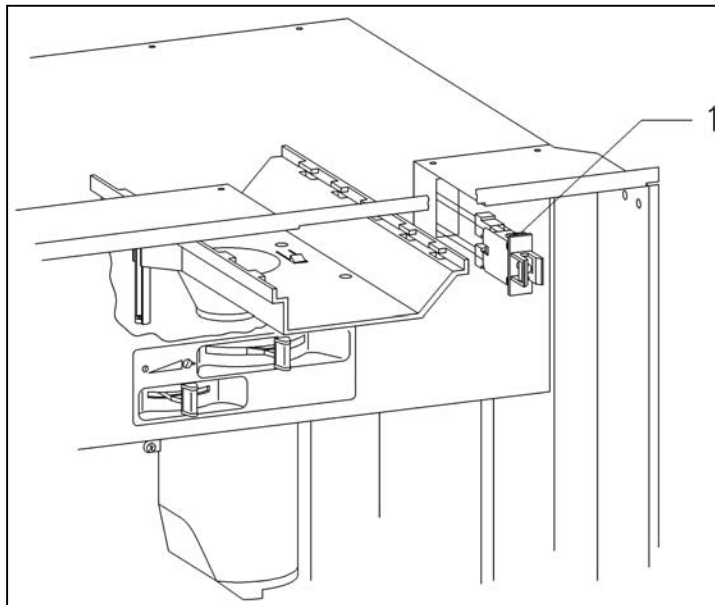

**Figure 5-5:** Door Switch (shown with appliance door in open position)

## 5.6 Base Plate - Removal

1. Remove the Lid, Mains and Rear Panel (5.1 to 5.3)
2. Open the door.
3. Remove the grounds container.
4. Remove the water tank.
5. Check if water is present in the drip tray with a finger through the opening under the water container.
6. If water is present, remove it via a suitable device / tool.
7. Remove the percolator unit.
8. Remove the coffee beans from their container.
9. Remove the base plate fixing screws.
10. Tilt the unit onto its rear.
11. Remove the base plate and disconnect its earth lead.

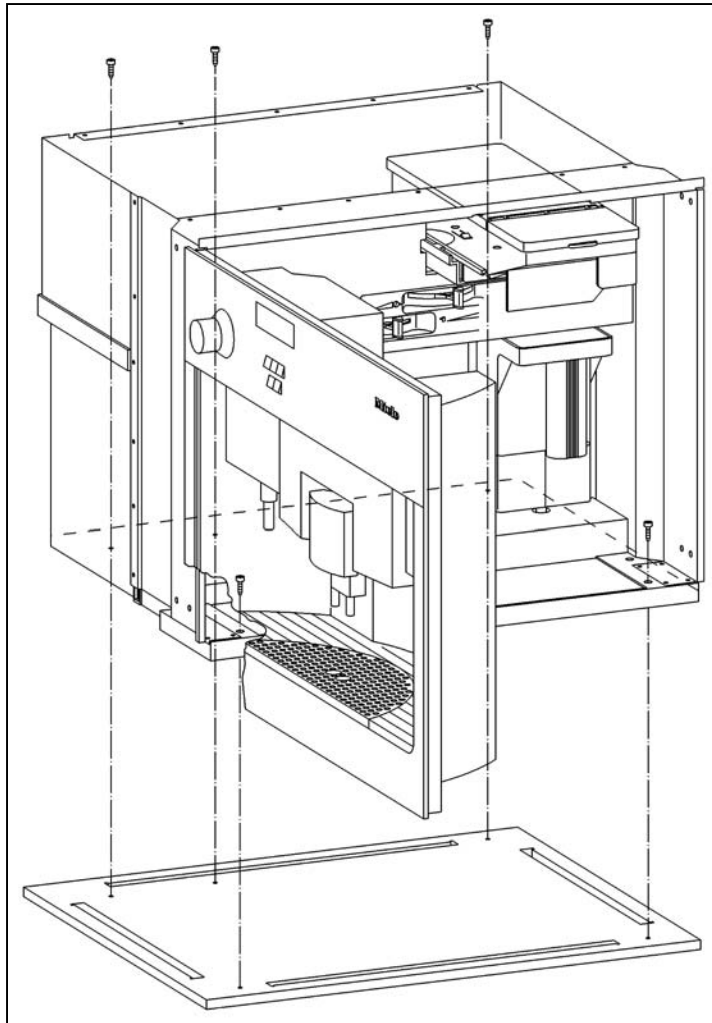
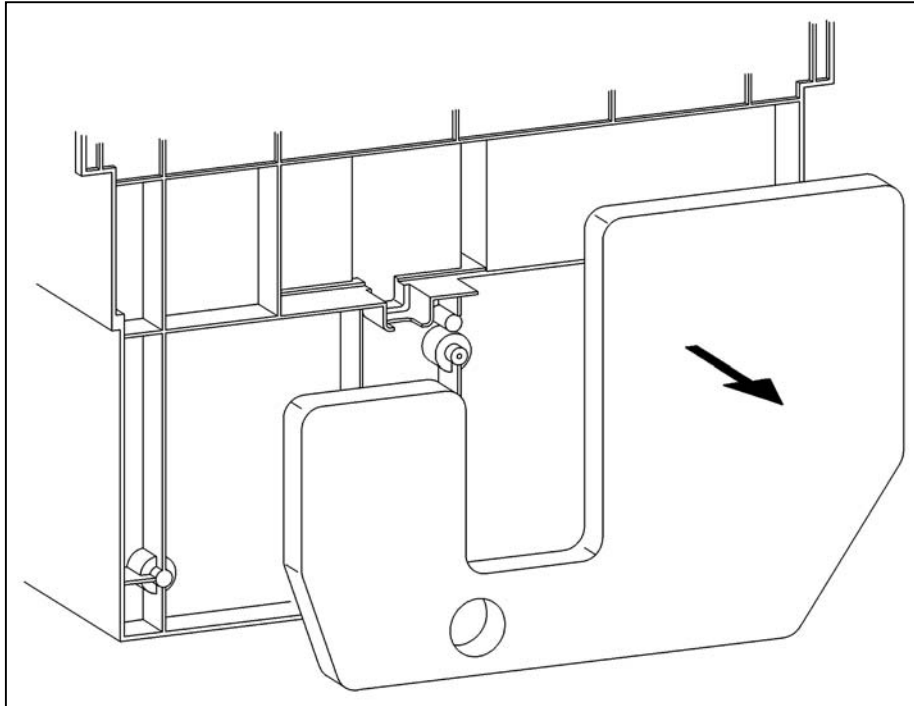

Figure 5-6: Base Plate – Removal

## Technical Information

**5.7 Drip Tray - Removal**

1. Remove the Lid, Mains and Rear Panel (5.1 to 5.3)
2. Remove the Base Plate (5.6)
3. Remove the drip tray.

**Figure 5-7:** Drip Tray



## 5.8 Overflow Switch Actuator Float - Removal

1. Remove the Lid, Mains and Rear Panel (5.1 to 5.3)
2. Remove the Base Plate (5.6)

**Note**

The orientation of the float before removal – ensure it is re-installed in the same direction.

3. Remove the Float.

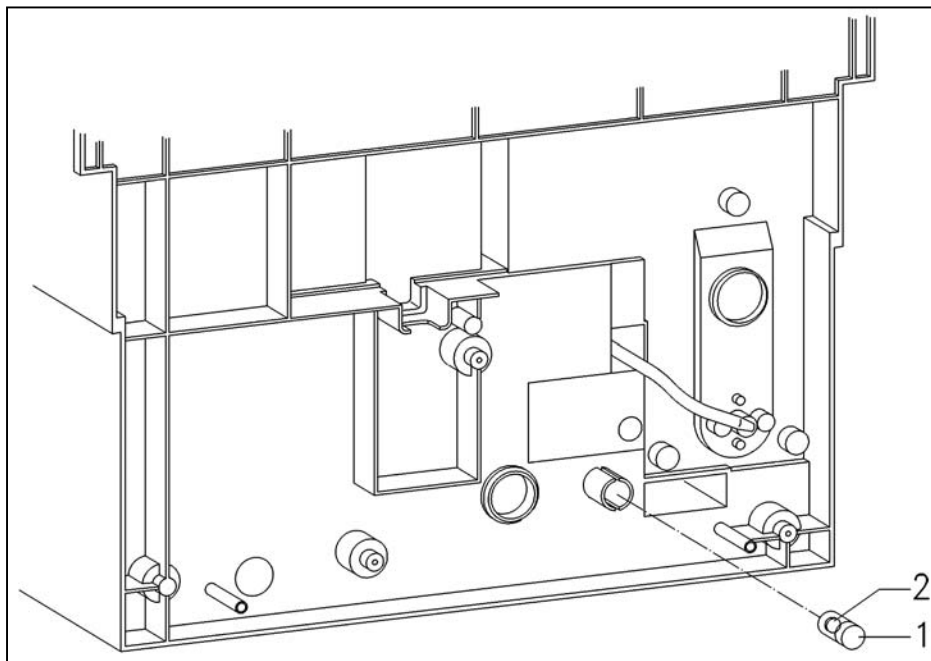
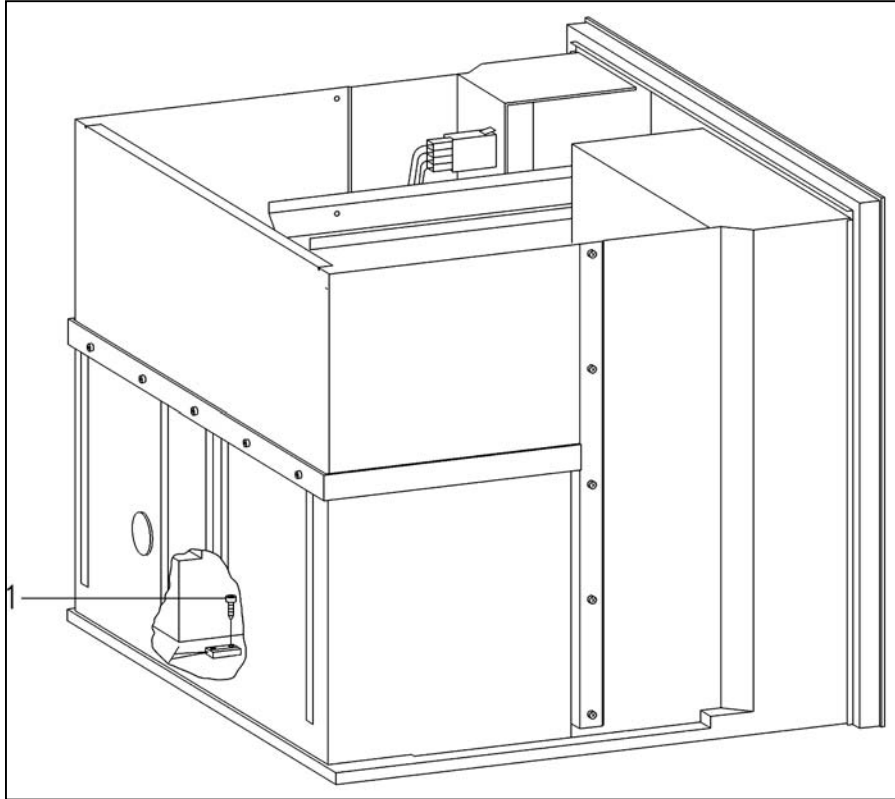

**Figure 5-8:** Overflow Switch Float

## Technical Information

**5.9 Overflow Switch (B8/3) - Removal**

1. Remove the Lid, Mains and Rear Panel (5.1 to 5.3)
2. Remove the overflow switch fixing screw (Figure 9 – Item 1).
3. Remove the overflow switch.
4. Disconnect the overflow switch connections from the electronic.

**Figure 5-9:** Overflow Switch

## 5.10 Fluorescent Lamp - Removal

Refer to the figure 5-10 below...

1. Open the door.
2. Unclip the cover and remove it.
3. Turn the lamp tube 90° in the direction to remove the lamp.

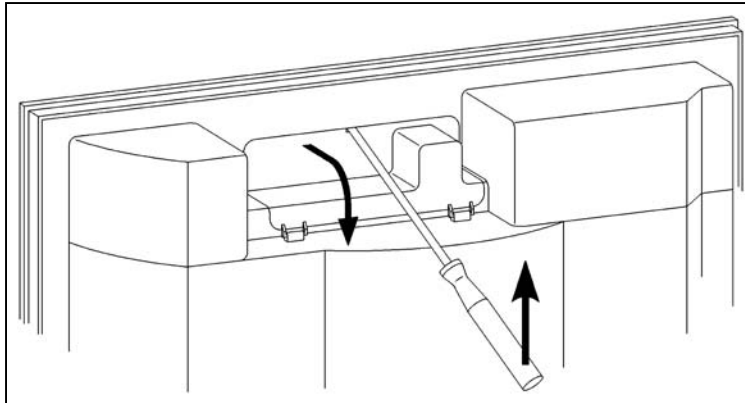

Figure 5-10: Fluorescent Lamp Access and Removal.

## 5.11 Lamp Starter - Removal

Refer to the figure 5-11 below...

1. Open the door.
2. Unclip the neon tube cover and remove it.
3. Turn the starter in the direction of the arrow.
4. Remove the starter.

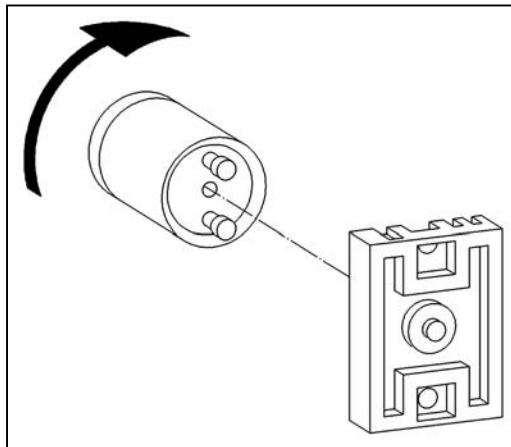

Figure 5-11: Starter Removal

## Technical Information

**5.12 Rear Door Panel - Removal**

Refer to figure 5-12.

1. Open the door.
2. Remove the upper rear panel fixing screws (Item 1).
3. Remove the lower rear panel fixing screws (Item 2).

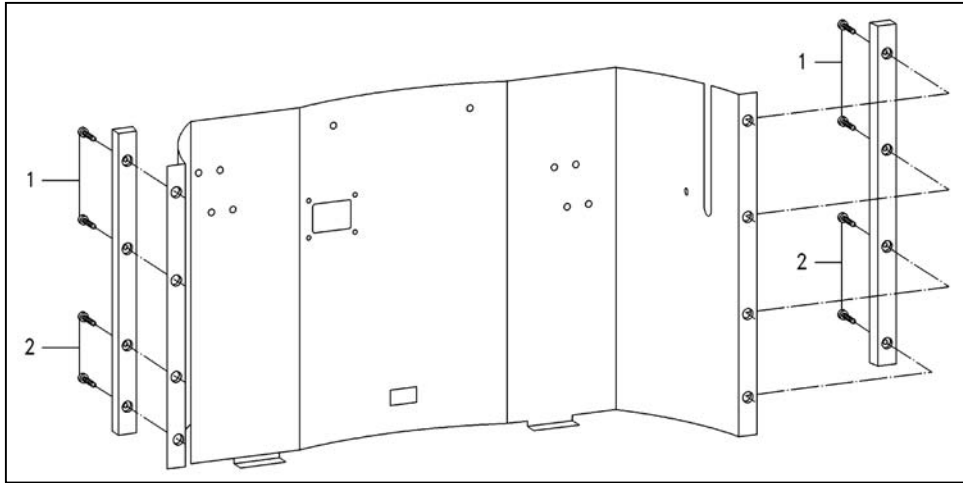

**Figure 5-12:** Rear Door Panel – Removal.

### 5.13 Fascia Panel Cover – Removal

1. Open the door.
2. Remove the Rear Door Panel (5.12).
3. Remove the cover fixing screws (Figure 12 – Item 3).
4. Remove the cover.

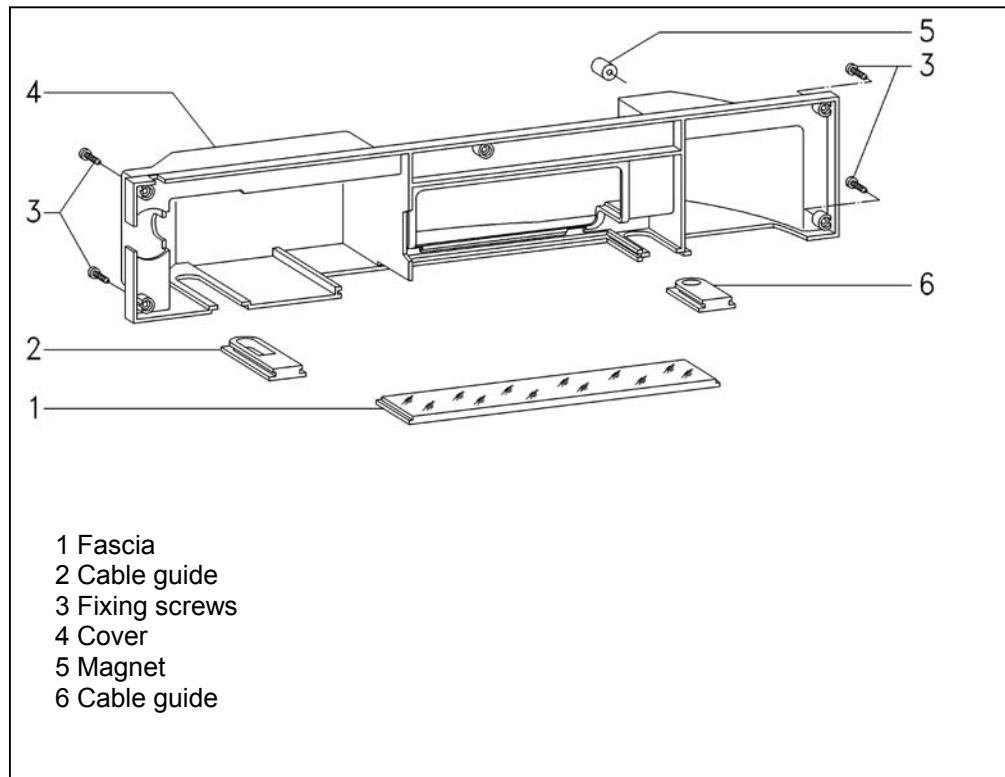

**Figure 5-13:** Fascia Panel Cover Assembly

## Technical Information

**5.14 Selector Switch - Removal**

Refer to figure 5-14.

1. Open the door.
2. Remove the Rear Door Panel and Fascia Panel Cover (5.12 & 5.13).
3. Disconnect the connections from the selector switch,
4. Remove the switch knob (Item 9).
5. Remove the selector switch with its housing from the fascia.
6. Remove the selector switch fixing screws.
7. Remove the selector switch from its housing.

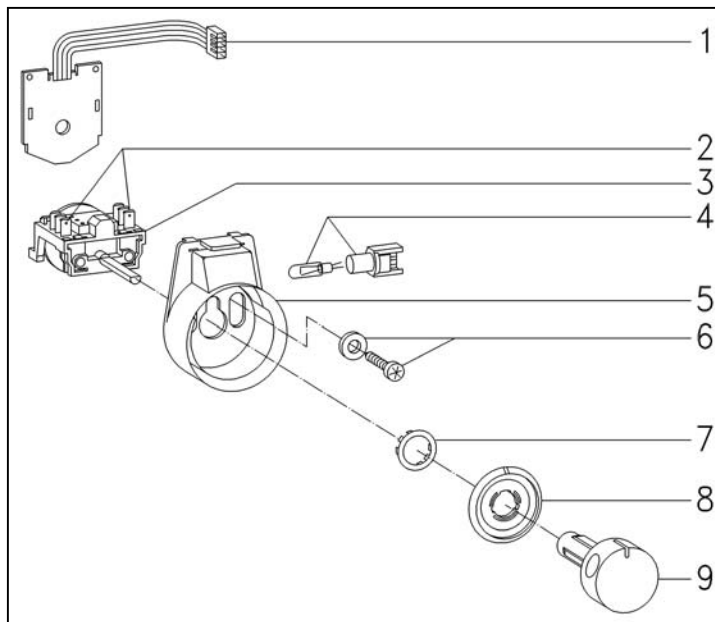
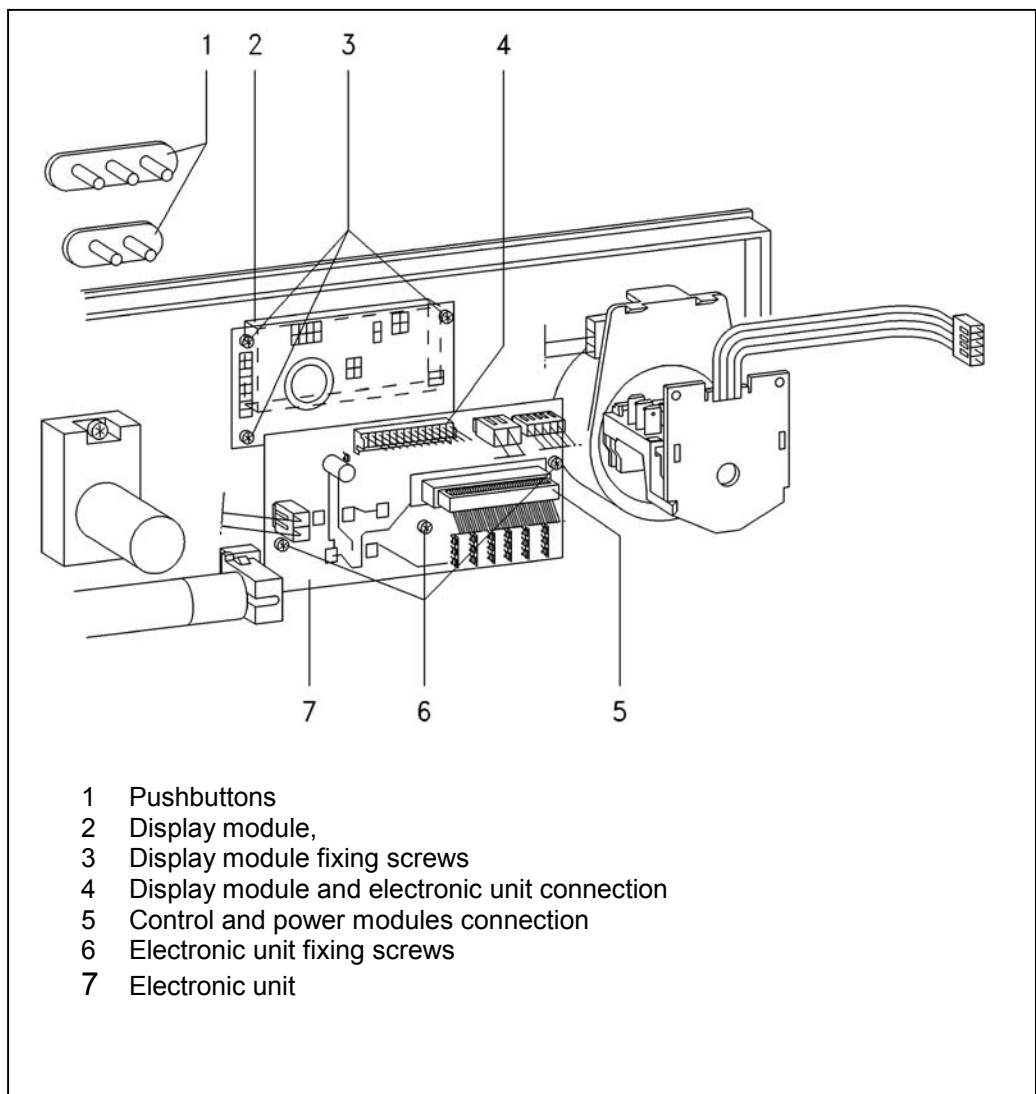

**Figure 5-14:** Selector Switch

## 5.15 Display Module Electronic - Removal

Refer to figure 5-15.

1. Open the door.
2. Remove the Rear Door Panel and Fascia Panel Cover (5.12 & 5.13).
3. Pull off the pushbutton knobs (Item 1).
4. Disconnect the connections from the electronic (Item 7).
5. Remove the electronic unit fixing screws (Item 6).
6. Remove the electronic unit.
7. Remove the display module fixing screws (Item 3).



**Figure 5-15:** Rear View of Front Door with Rear Panel Removed.

## 5.16 Coffee Dispensing Nozzle - Removal

Refer to Figure 5-16.

1. Open the door.
2. Remove the grille and drip tray from the door.
3. Remove the fixing screws from the white panel under and behind the nozzle.
4. Remove the white panel.

### Note

The two fixing screws for the moveable coffee-dispensing nozzle are on the rear of the dispenser unit.

5. Remove the 2 screws from the coffee-dispensing nozzle by hand.
6. Pull out the hose (Item 6), from the outlet, (Item 7).
7. Pull out the moveable coffee dispensing nozzle (Item 9), to its end stop.
8. Unclip the outlet and remove it.
9. Remove the moveable coffee dispensing nozzle.

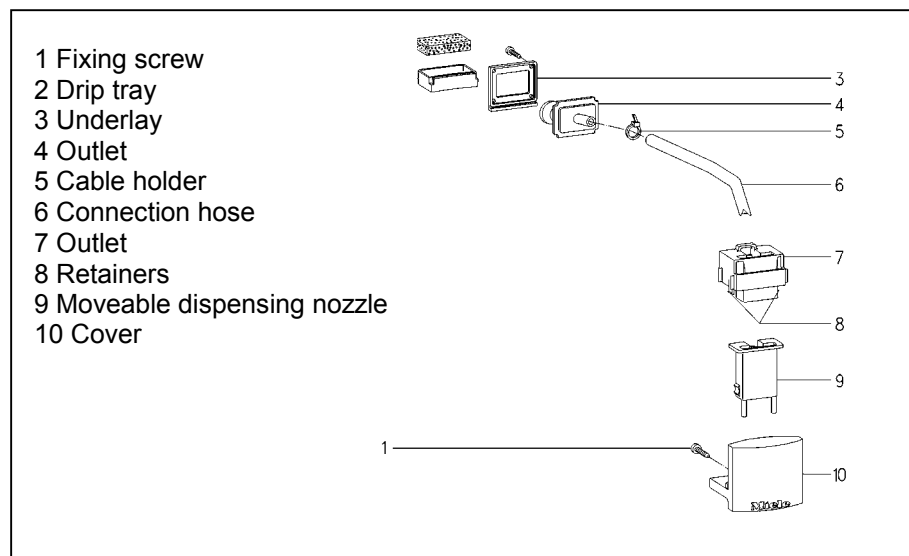

Figure 5-16: Components of the Coffee Dispensing Nozzle.



## 5.17 Coffee Dispensing Nozzle - Fitting

Refer to figure 5-16.

1. Slide the outlet (Item 7), onto the connection hose (Item 6).
2. Position the moveable coffee dispensing nozzle, (Item 9), in the cover (Item 10).
3. Clip the outlet (Item 7), in the cover (Item 10).

**Note**

The two fixing screws for the coffee dispensing nozzle should be tightened by hand only as they can easily be over tightened.

4. Fit the Coffee Dispensing Nozzle in the frame. Using a suitable bit, tighten the two fixing screws by hand.
5. Refit the white panel and screw it in position.

## Technical Information

**5.18 Steam Valve and Steam Valve Switch (S79) – Removal**

Refer to Figure 5-17.

1. Open the door.
2. Remove the Rear Door Panel and Fascia Panel Cover (5.12 & 5.13).
3. Pull off the switch knob (Item 8).
4. Remove the holder fixing screws (Item 3).
5. Remove the holder.
6. Remove the steam generator switch screws (Item 10).
7. Remove the steam generator switch.
8. Disconnect the steam generator switch connections.

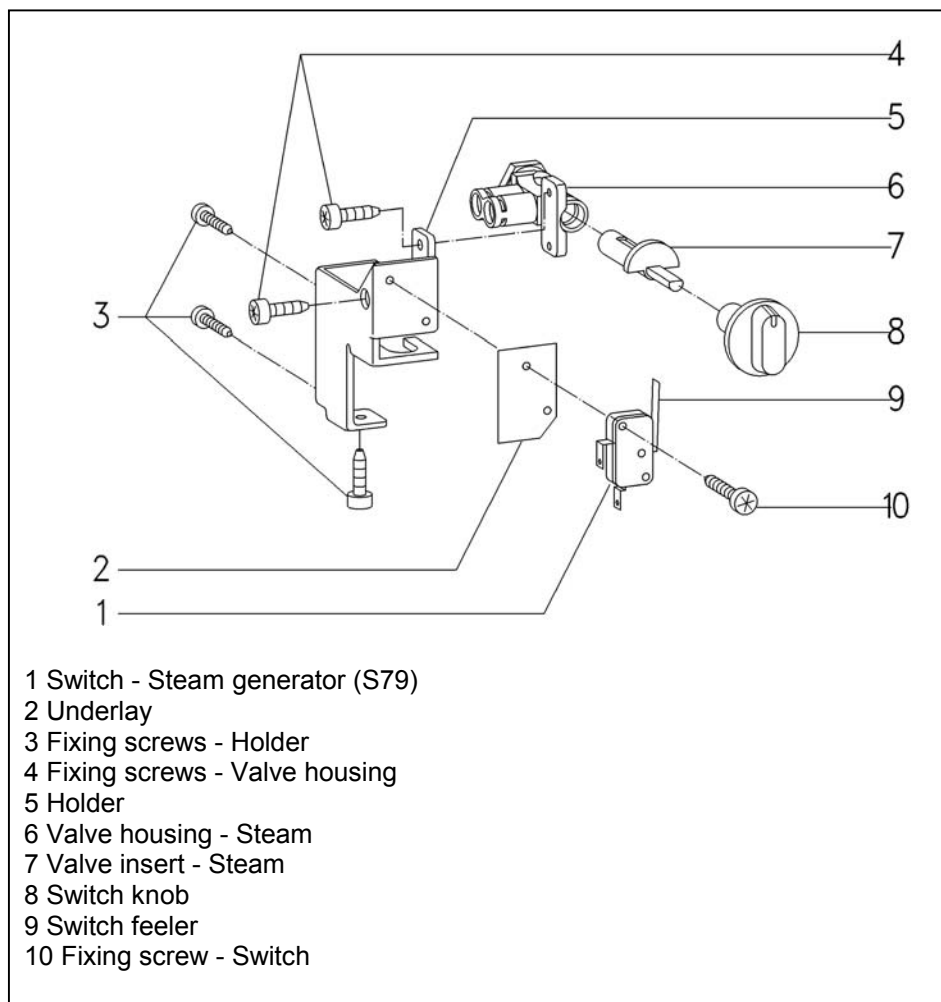
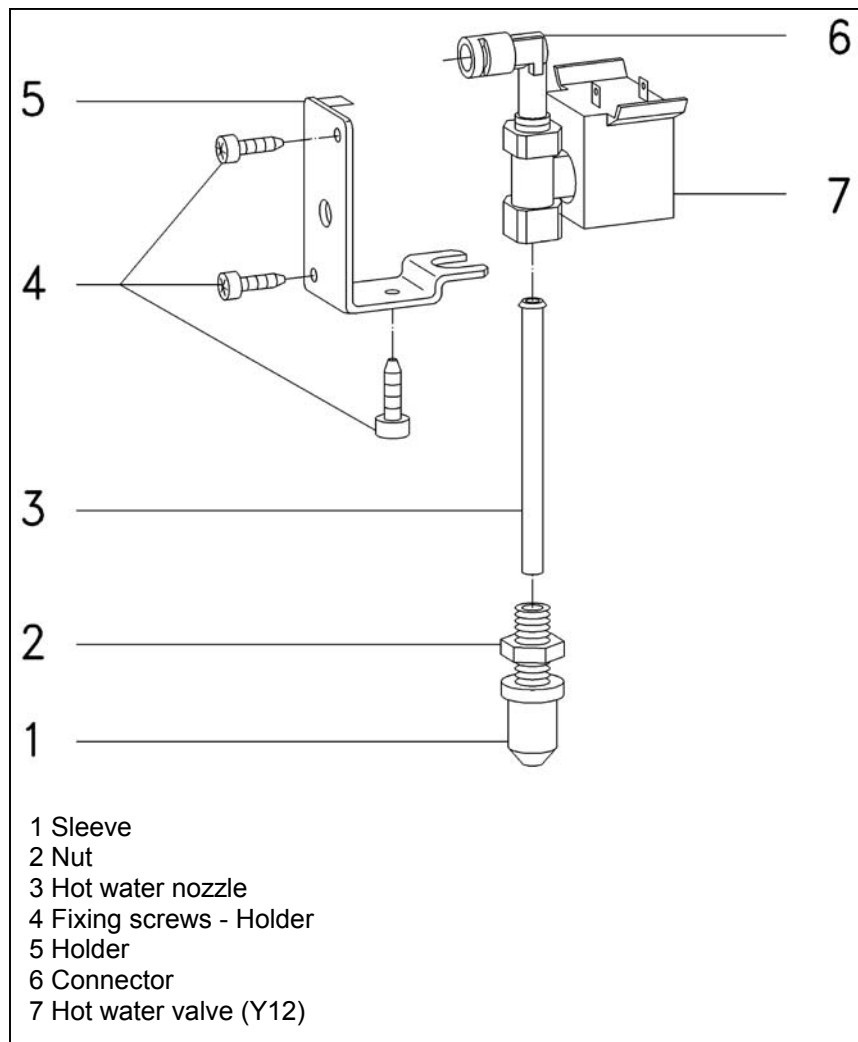

**Figure 5-17:** Components of Steam Valve and Steam Valve Switch

## 5.19 Hot Water Nozzle – Removal

Refer to figure 5-18.

1. Open the door.
2. Remove the Rear Door Panel and Fascia Panel Cover (5.12 & 5.13).
3. Loosen the nut (Item 2).
4. Remove the holder (Item 5).
5. Unscrew the sleeve, (Item 1) from the connector (Fig. 6).
6. Pull out the hot water nozzle (Item 3), from the connector.



**Figure 5-18:** Hot Water Valve Components

---

**Technical Information****5.20 Hot Water Valve (Y12) – Removal**

Refer to figure 5-18.

1. Open the door.
2. Remove the Rear Door Panel and Fascia Panel Cover (5.12 & 5.13).
3. Disconnect the connections from the hot water valve (Item 7).
4. Loosen the hot water valve nuts.
5. Pull out the hot water valve from the connector (Item 6).

**5.21 Coffee Temperature - Check**

1. Set the grinding grade to medium.
2. Set the coffee quantity to medium.
3. Set the coffee (medium size) temperature to medium (standard setting).
4. Set the number of pulses for the flow meter for 1 coffee to 350 (standard setting), see — . Diagnosis mode.
5. Prepare 3 coffees (medium size) one after the other.
6. When the fourth coffee is being dispensed, hold the sensor probe directly in the flow of coffee.

If the temperature at the coffee dispenser is 171° F - 194° F the unit is in order.

**5.22 Brew Unit — Removal (in start/home position)**

1. Open the door.
2. Remove the grounds container.
3. Hold the handle and press on the part marked PRESS.
4. Remove the percolator from the unit.

## 5.23 Brew Unit — Removal ( NOT in start/home position)

### **Warning**

This procedure will remove the brew unit from the appliance without damages. However., after the brew unit is removed; the drives must be carefully inspected (and repaired if necessary) then placed into the start (home) position via the service mode.

Before performing this procedure close the front door, turn the power on to initiate a drive reset during the start-up sequence.

Once “Ready...” is displayed; open the front door and attempt to remove the brew unit. If the brew unit still cannot be easily removed, continue as follows:

Refer to figures 5-19 and 5-20.

1. Open front door - Remove the waste container.
2. Locate the Philips screw (Figure 19 – Item 2).
3. Remove the Philips screw.
4. Use a small flat tip screwdriver to lift up on the retaining tab (Figure 20).
5. Grasp the brew unit handle and pull the brew unit out till the connection socket on the brew unit (Figure 19 – Item 1) unsnaps from the brew unit and remains inside the appliance attached to the water nozzle.
6. Remove the brew unit.
7. Slide the connection down to remove it from the appliance.
8. Re~install the connection socket to the brew unit.
9. Carefully inspect the drives for defects.
10. Test the starting (home) switch and brew unit position switch for proper operation.

## Technical Information

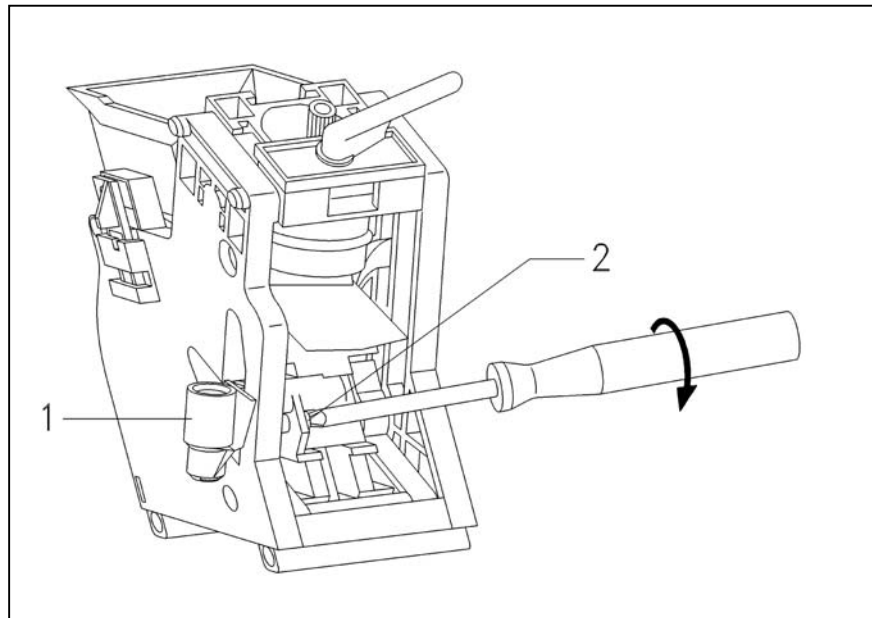

**Figure 5-19:** Brew Unit (1) Connection Socket (2) Retaining Screw

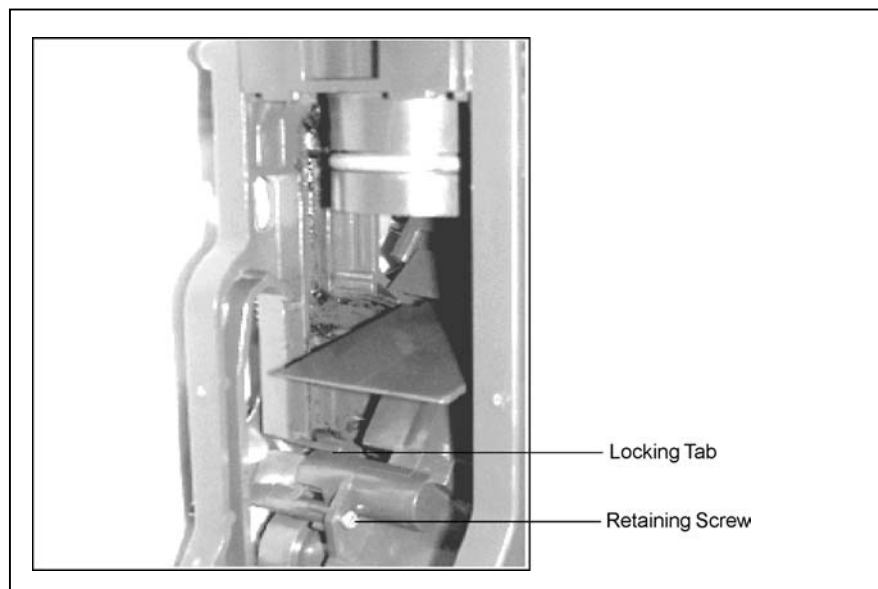

**Figure 5-20:** Brew Unit Connection Socket Retaining Screw and Retaining Tab.

## 5.24 Brew Unit - Installation

Slide the brew unit into position in the appliance until the locking mechanism engages with the drive mounting plate.

**Note**

Do not press the part marked PRESS during the installation of the brew unit.

## 5.25 Brew Unit – Cleaning Procedure

**Note**

- Clean the brew unit by hand only. The moving parts and the rubber gaskets SHOULD NOT be cleaned in a dishwasher.

- Lubricate the brew unit with silicon every 500 cups (see "Lubricating the brew unit").

1. Remove the waste unit. The brew unit can only be removed after the waste unit has been taken out.
2. Grasp the brew unit by the handle and press with the thumb on "PRESS". (Figure 21 – Item 1).

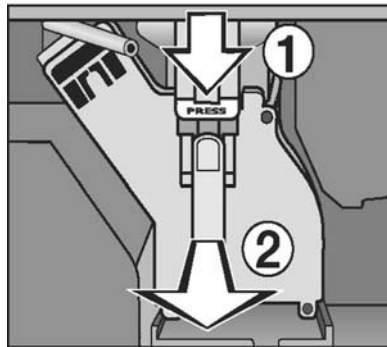

**Figure 5-21:** Brew Unit – Removal for Cleaning

## Technical Information

3. Pull the brew unit out (Figure 21 – Item 2).
4. Clean the brew unit thoroughly under running warm water without detergent.
5. Rub away coffee residues from the steel filters with a sponge.
6. Dry the funnel to prevent ground coffee from sticking.
7. After cleaning press "PRESS".

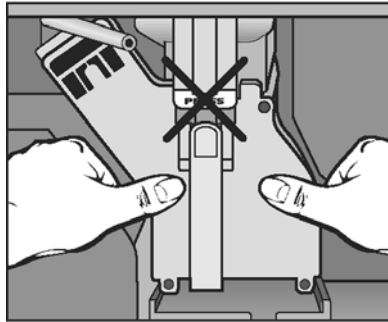

**Figure 5-22:** Brew unit installation

8. Push the brew unit in the track straight into the appliance without pressing "PRESS" until it clicks in place.

## 5.26 Brew Unit – Filter Cleaning

1. Wipe away coffee residues from the steel filter in the funnel of the brew unit with a sponge.
2. The filters can be removed for thorough cleaning.
3. Remove the brew unit.
4. Fit a 5mm Allen Wrench to the connection point in the brew unit. Turn counterclockwise while supporting the chrome filter from below. Remove the filter by lifting it from the brew unit.
5. Access the second filter by placing a long shaft Philips Screwdriver through the center of the funnel and remove the screw in the center of the filter.
6. Manually move the brew unit into the "brew position".
7. Turn brew upside down – filter will fall out.
8. Clean both sides of the filter with hot water and dry.
9. Re-install the second filter back in position.
10. Manually move the brew unit to the "home position"
11. Re-install the Philips screw in the center of the filter.
12. Return the first filter to the brew unit and secure by turning the Allen Wrench clockwise.



## 5.27 Brew Unit - Degreasing via the Rinse Cycle

### Note

The natural oil found in coffee can cause the brew unit to clog. The message "Rinsing cycle" will flash in the message window after 500 cups to remind you to clean the unit using "cleaning tablets"

These specialty-cleaning tablets can be purchased from Miele via the Technical Support Center at 1-800-999-1360.

1. Remove the waste unit.
2. Take out the brew unit and put the detergent tablet in the brew unit funnel. Fig. 5-23.

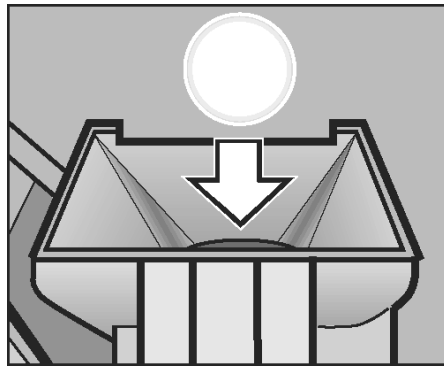

**Figure 5-23:** Cleaning tablet being placed into the brew unit funnel.

3. Return the brew unit and waste unit to the appliance and close the door.
4. Set a 3 cup (25 oz) container under the coffee dispensers.
5. Press the rinse/ pre-warm button. (The unit must be pre-heated and ready to use otherwise the button will not respond.)
6. The display will read:



7. Press ▼ to select "Rinsing cycle" with the asterisk.

---

**Technical Information**

8. Press ENTER. The display will read:



**RINSING CYCLE**

A small amount of water will flow out the coffee dispensers. After a pause more water will flow out. This process will run 4 times, dispensing 2 cups (17 oz) of hot water. The whole process lasts about 5 minutes.

At the end of the cleaning cycle the display will read:



**SELECT PRODUCT  
READY FOR USE**

The brew unit is now clean and ready to use.

## 5.28 Brew Unit – Lubrication

1. Remove the Brew Unit.

**Note**

- Check that the brew unit is in the basic position with the funnel slightly lifted and the socket in vertical position.
- Ensure the correct lubricant (Miele P/N 5132001) is used for this procedure. Lubricant is available through the Miele Technical Support Center at: 1-800-999-1360.

2. Refer to figure 5-24 below; lubricate the following:

- A: joints
- B: axel
- C: tracks
- D: gasket

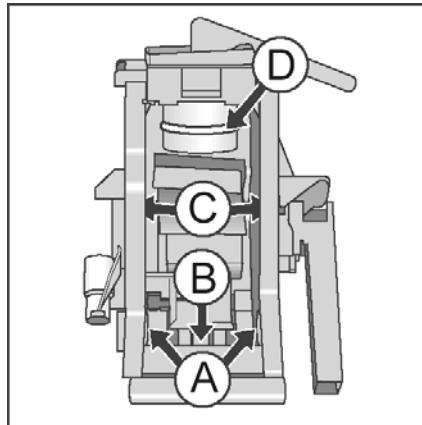

Figure 5-24: Brew unit lubrication points

3. Refer to figure 25 below; lubricate the following:

- E: bolt assembly
- F: joints

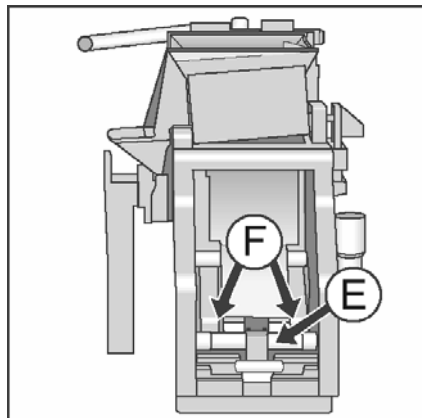

Figure 5-25: Brew unit lubrication points

4. Re-Install the Brew Unit into the appliance.

## Technical Information

**5.29 Brew Unit – Manual Reset to “Home Position”  
(Brew Unit not installed in appliance)**

Refer to figure 5-26

3. Press the latch **A**; and press the funnel down **B**.
4. Push the connection piece to the far left position **C**.
5. Press "PRESS" once.

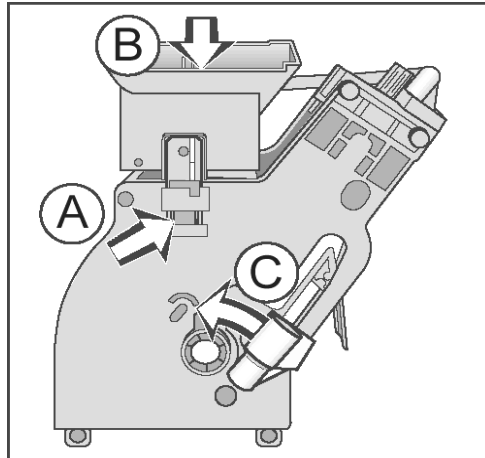

**Figure 5-26:** Moving the brew unit to home position.

6. The “home” position (Figure 27) after resetting the Brew Unit.  
The Brew Unit can now be reinstalled into the appliance.

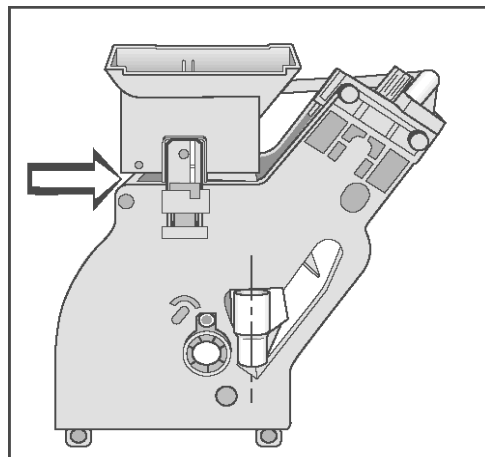

**Figure 5-27:** Brew unit in reset position.

### 5.30 Brew Unit Creamer Valve - Removal

1. Remove the Brew Unit
2. Remove the output fixing screws.
3. Remove the output.
4. Remove the spring with Creamer Valve.

### 5.31 Brew Unit Handle - Removal

1. Remove the Brew Unit from the appliance.
2. Press the handle retaining lugs inwards (Figure 5-28).
3. Remove the handle.

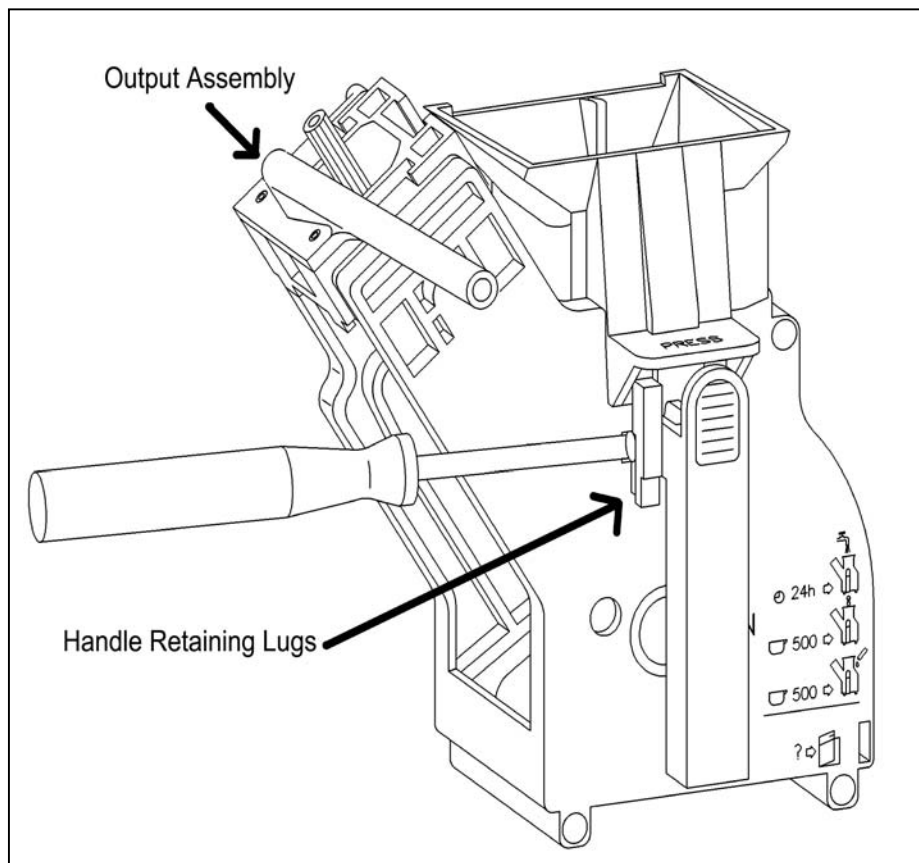

**Figure 5-28:** Brew Unit Highlighting the Output Assembly (Covers the Creamer Valve) and the Retaining Lugs Securing the Handle to the Assembly.

## Technical Information

**5.32 Brew Unit Funnel - Removal**

1. Remove the Brew Unit from the appliance.
2. Press the funnel locking lug (Figure 29, Item 1), so that the funnel is no longer raised.
3. Lever the funnel upwards out of its holder (Figure 5-30).

**Note**

When refitting the Funnel, ensure the spring (Figure 5-30, Item 1) is seated correctly.

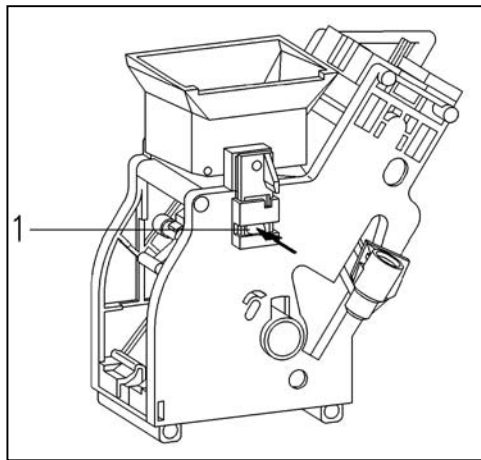

**Figure 5-29:** Rear of Brew Unit, highlighting the funnel lock

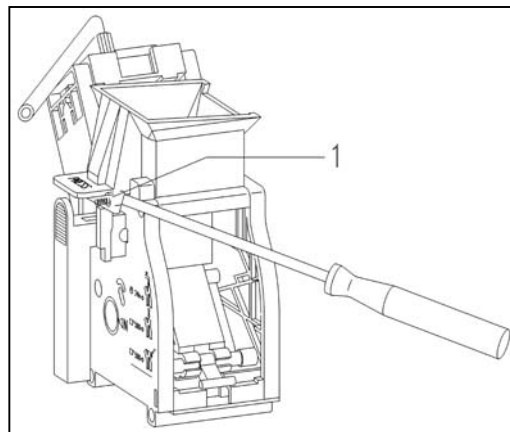

**Figure 5-30:** Front of Brew Unit, showing spring location and holder

### 5.33 Brew Unit Ram - Service

1. Remove the Brew Unit from the appliance.
2. Remove the funnel (5.32).
3. Remove the bottom filter screw and filter (Figure 5-31, Items 1 & 2).

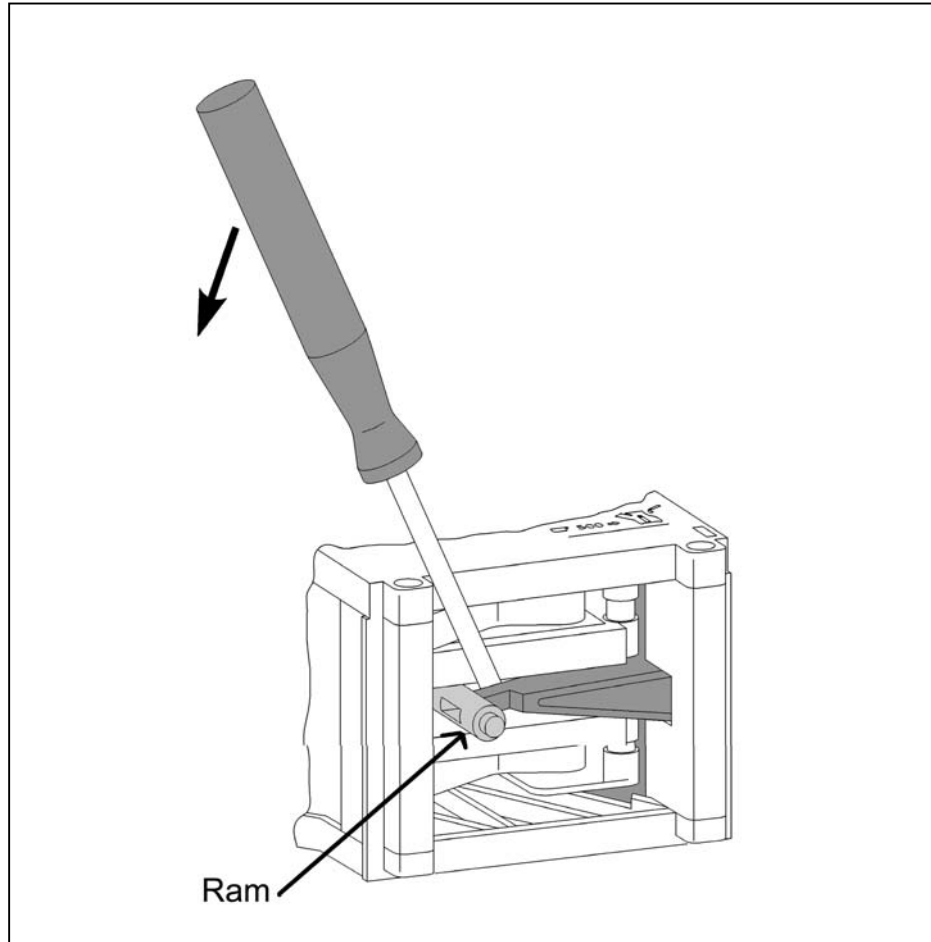
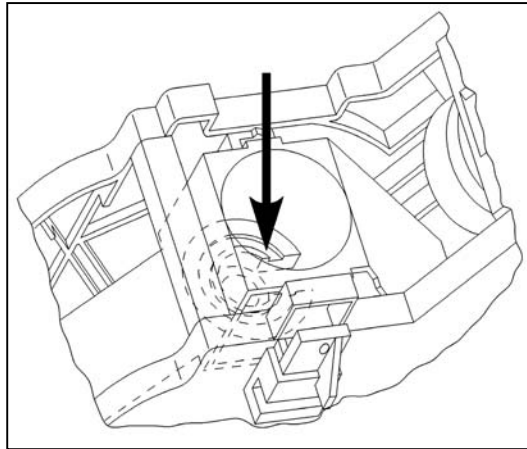

**Figure 5-31:** Releasing the ram from the bottom of the Brew Unit.

4. Unclip the lever from the ram.
5. Pull the ram outward to remove from the brew unit.

**Technical Information**

6. Clean the brewing chamber (Figure 32), ram and bottom filter by hand with warm water without detergent, then dry.
7. Apply silicone grease to the ram lubrication points (Figure 5-33, Item 3).



**Figure 5-32:** Brewing unit chamber inside the brew unit assembly.

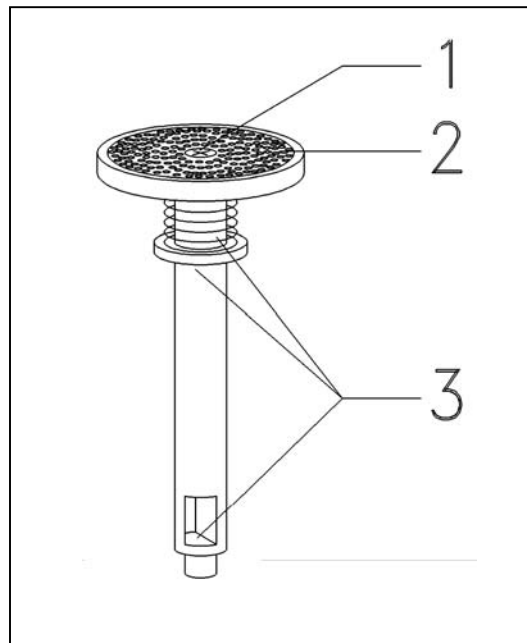
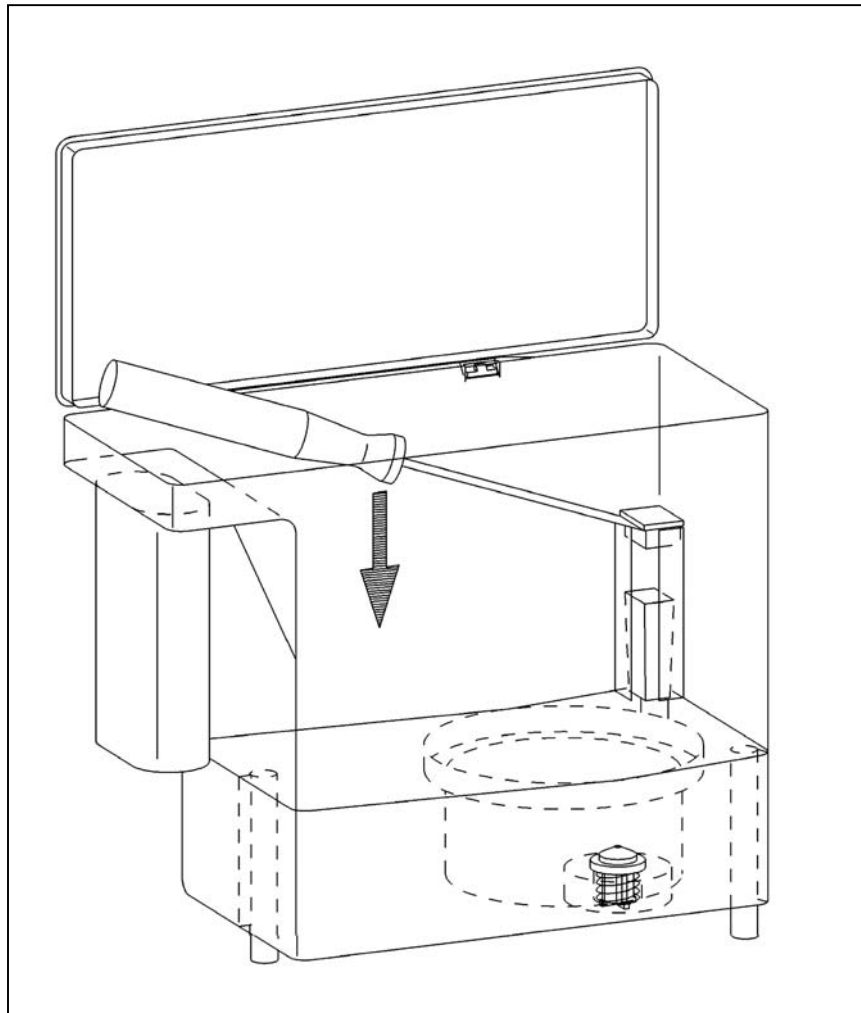

**Figure 5-33:** Ram assembly. (1) Filter Screw  
(2) Filter (3) Lubrication points



### 5.34 Water Tank Level Indicator Float - Removal

1. Open the door.
2. Remove the Water Tank.
3. Lever off the cap from the Water Tank level indicator.
4. Remove the Water Tank level indicator.

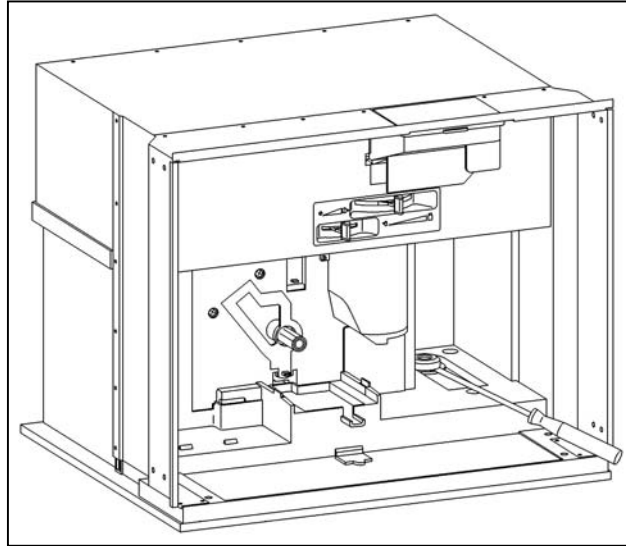

**Figure 5-34:** Removing the cap to access the float in the Water Tank

## Technical Information

**5.35 Water Tank Valve Sealing Ring - Removal**

1. Open the door.
2. Remove the Water Tank.



**Figure 5-35:** Levering off the Lip Seal Cap.

3. Lever off the Lip Seal Cap (Figure 35).
4. Remove the Lip Seal (Figure 16, Item 1).

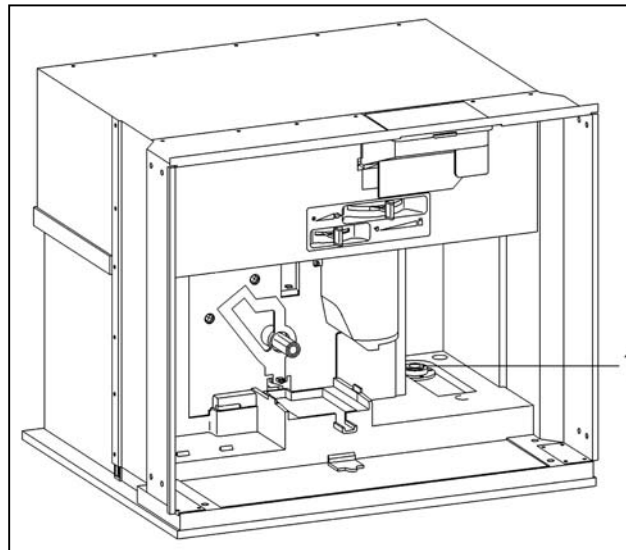

**Figure 5-36:** Removing the Lip Seal

### 5.36 Lower Section of Tank Valve - Removal

1. Open the door.
2. Remove the Water Tank.
3. Lip seal removal.
4. Remove the lower part of the valve fixing screws (Figure 37 – Item 1).

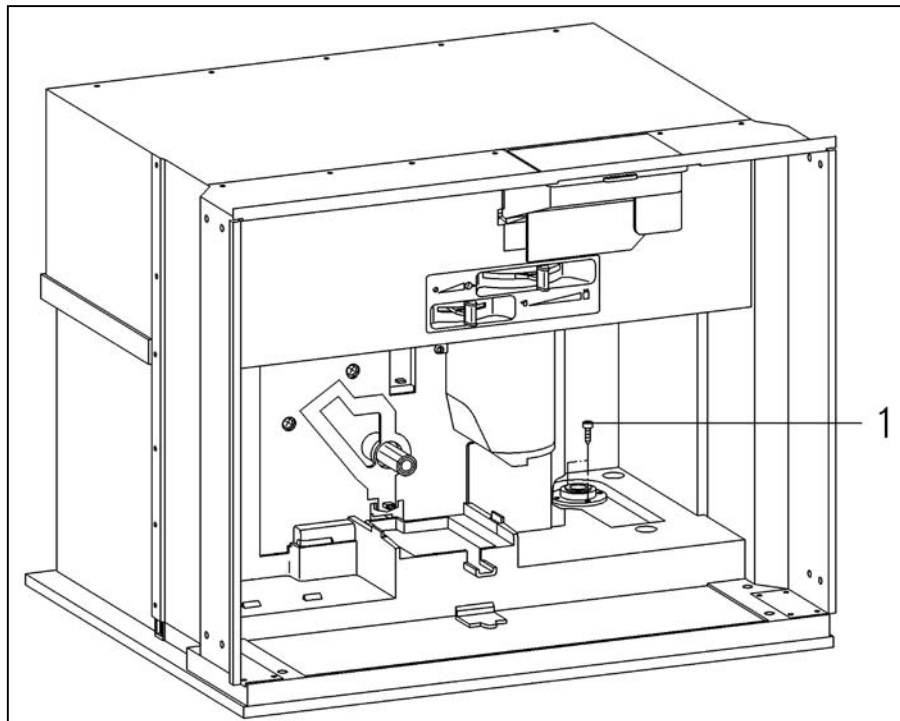

**Figure 5-37:** Water Tank Lip Seal - Removal.

## Technical Information

5. Remove the Bottom Plate and Drip Tray (5.6 & 5.7)
6. Disconnect the lower part of the valve connections,
7. Remove the lower part of the valve.

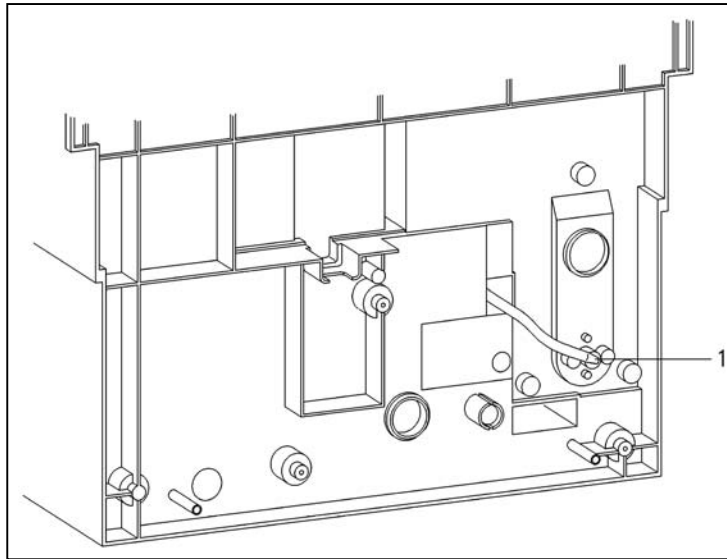

**Figure 5-38:** Underside view of the CVA610 with Base Plate and Drip Tray removed.

### 5.37 Bean Container - Removal

1. Open the door.
2. Remove the Beans Container end stop screw (Figure 39).
3. Hold a suitable vessel under the container to collect the beans that will fall from the opening in the Beans Container.

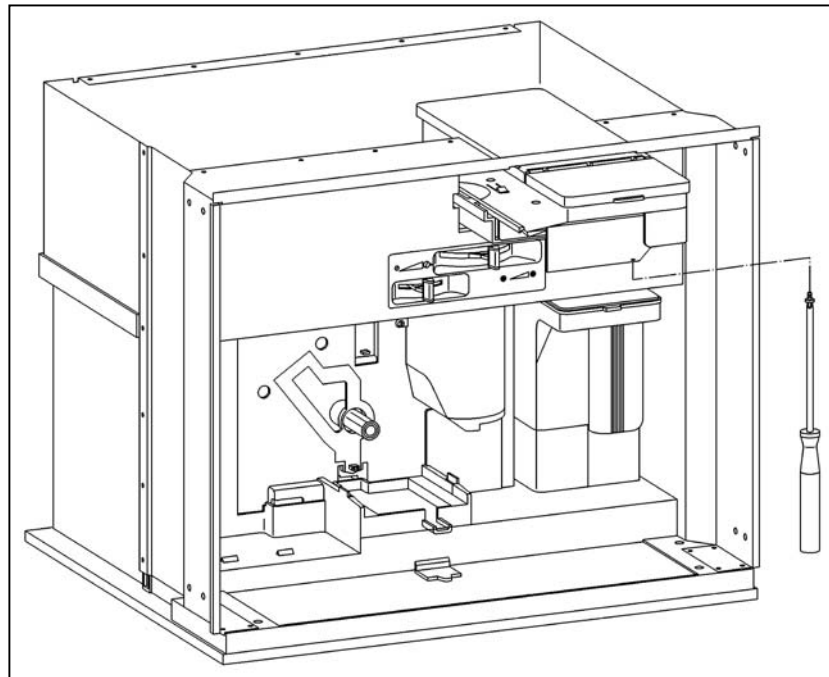

**Figure 5-39:** Removing the Bean Container.

## Technical Information

**5.38 Bean Container Guide - Removal**

1. Open the door.
2. Perform the Beans Container. (5.37)
3. Remove the Waste Container, Brew Unit and Water Tank.
4. Remove the Top Lid (5.1).
5. Remove the screws (Figure 5-40 - Item 2).
6. Remove the guide and carrier, (Figure 5-40 – Item 1).

**Note**

When refitting, first fit the carrier (Figure 5-40 – Item 1), in position and then fit the guide on the carrier.

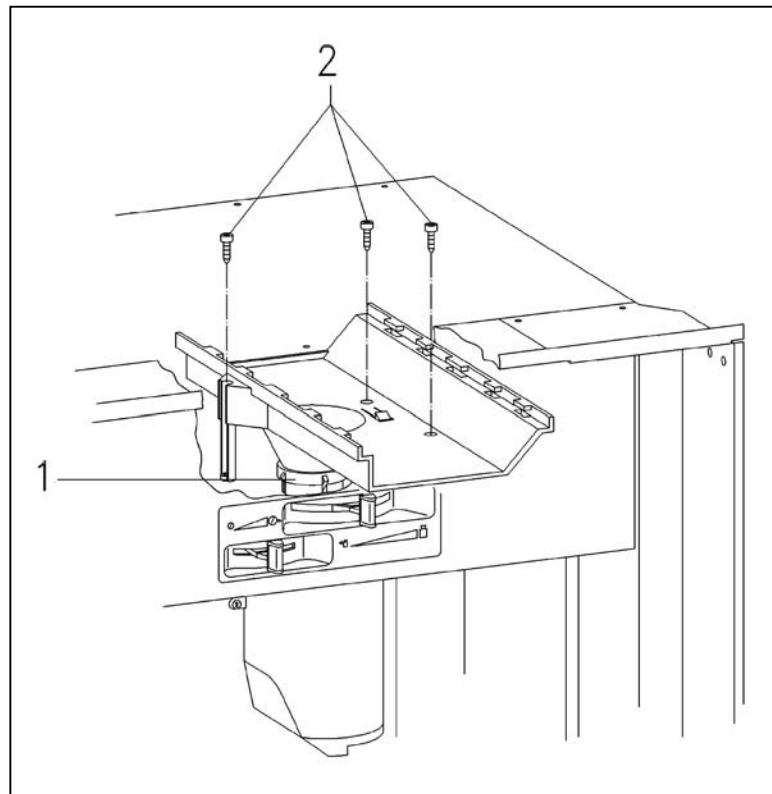

**Figure 5-40:** Removing the Beans Container guide

## 5.39 Grinder Unit - Disassembly

**Note**

The grinder ring (Figure 5-41, Item 5), and grinder cone (Figure 41 – Item 6), should always be replaced together.

1. Open the door.
2. Remove the Beans Container. (5.37).
3. Remove the Waste Container, Brew Unit and Water Tank.
4. Remove the Top Lid (5.1).
5. Remove the Beans Container Guide removal (5.38).
6. Set the Grinding Adjustment Lever to the mid setting.

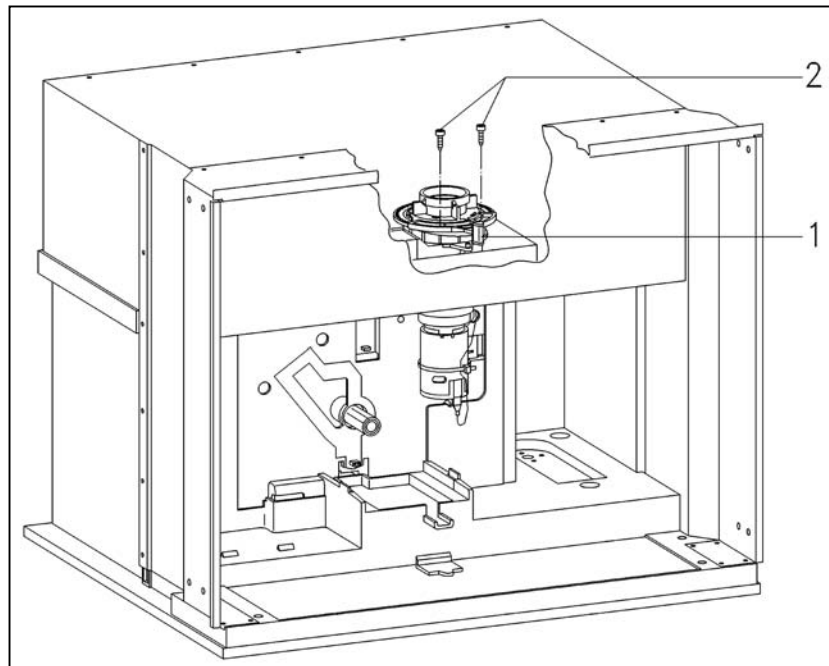
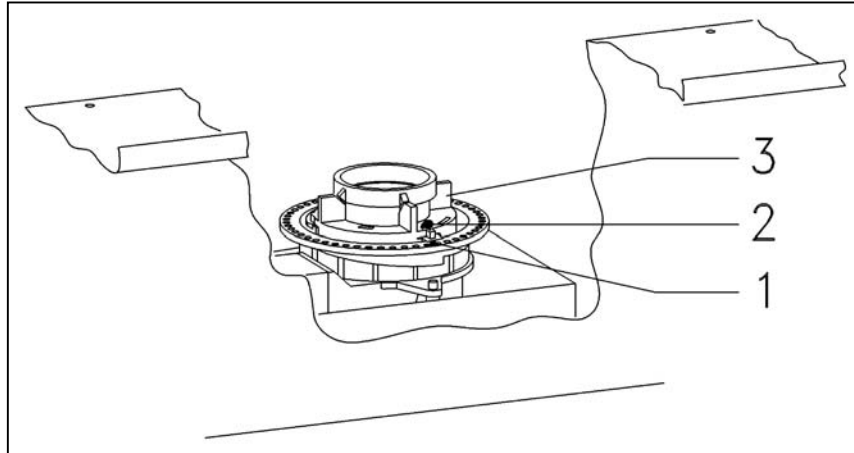

**Figure 5-41:** Accessing the grinder

7. Pull off the handle (Figure 5-41, Item 1).
8. Remove the adjustment lever fixing screws (Figure 5- 41, Item 2).
9. Remove the lever.

## Technical Information

10. Turn the adjustment ring (Figure 5-42, Item 1), counterclockwise until the blue marking aligns with the blue marking on the carrier (Figure 5-42, Item 2).



**Figure 5-42:** Upper Section of Grinder (1) Adjustment Ring, (2) Carrier & (3) Bracket.

11. Remove the bracket (Figure 5-42, Item 3)
12. Remove coffee residues, e.g. with a vacuum cleaner.

**Note**

The grinding cone fixing screw has a left-hand thread.

13. Remove the grinding cone fixing screw (Figure 5-43, Item 1) by turning it clockwise.
14. Remove the intake worm gear (Figure 5-43, Item 2).
15. Remove the washer (Figure 5-43, Item 3).



**Note**

When the grinding cone (Figure 5-43, Item 6), is removed the balls, (Figure 5-43, Item 8), may stick to it and then fall off.

Refer to figure 5-43.

16. Remove the grinding cone (Item 6).

17. Remove the balls (Item 8).

18. Remove the mounting (Item 7).

19. Remove the springs (Item 9).

20. Remove the carriers (Item 10).

21. Remove the felt ring (Item 11).

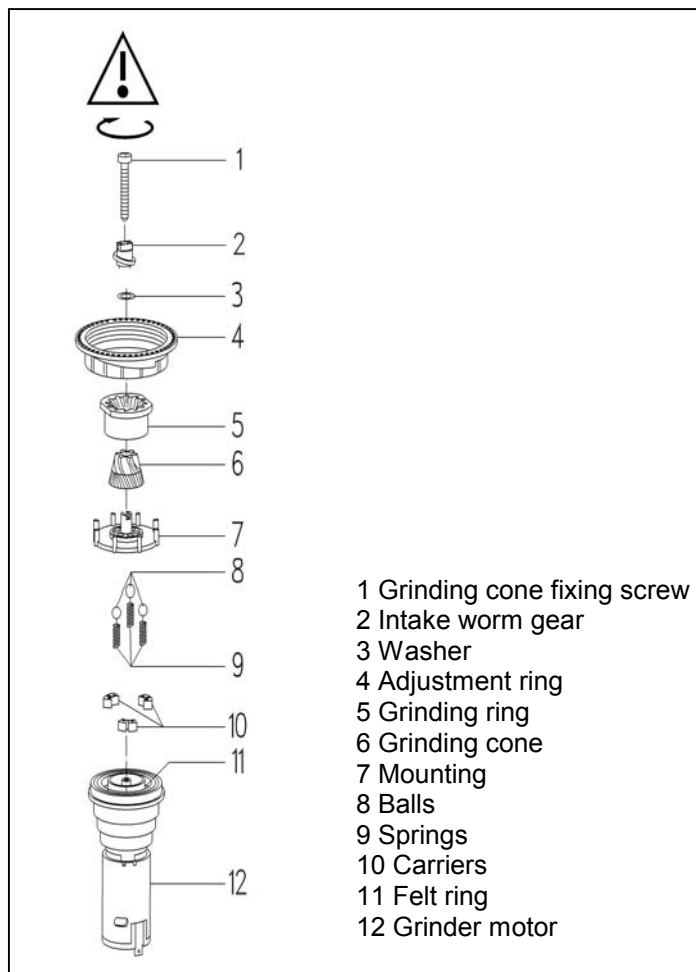

**Figure 5-43:** Grinder

## Technical Information

**5.40 Grinder Unit - Assembly & Basic Setting**

Refer to Figure 5-43 on the previous page...

**Note**

The grinder ring (Item 6), and grinder cone, (Item 5), should only be exchanged together.

1. Fit the felt ring (Item 11).
2. Fit the carriers (Item 10).
3. Fit the mounting (Item 7).
4. Fit the springs (Item 9).
5. Fit the balls (Item 8).
6. Fit the grinding cone (item 6); ensure the balls are seated in the grinding cone.
7. Fit the washer (Item 3).
8. Fit the intake worm gear (Item 2), press it down, and turn it until the coupling engages.

**Note**

The grinding cone fixing screw (Item 1), has a left-hand thread.

9. Tighten the grinding cone fixing screw, (Item 1), counter clockwise. Ensure the intake worm gear coupling has engaged properly.

**Note**

Before setting the grinder, remove all coffee from the grinder.

10. Fit the bracket (Item 3).
11. The blue marking on the carrier (Item 2), has the same position as the blue marking on the adjustment ring (item 1); both point toward the front of the appliance.
12. Turn the adjustment ring clockwise as far as possible.
13. Turn the adjustment ring counterclockwise by 6 settings so that the adjustment lever can be secured at a mid setting.
14. Fit the adjustment lever such that the grinder is set to a medium grinding grade.
15. Tighten the adjustment lever fixing screws.
16. Push on the handle.

## 5.41 Grinder Unit - Removal

1. Open the door.
2. Perform the Beans container removal (5.37).
3. Remove the Waste Container, Brew Unit and Water Tank.
4. Remove the Top Lid (5.1)
5. Remove the Beans Container Guide (5.38).
6. Adjustment slide switch frame removal (5.4).
7. Remove the adjustment lever fixing screws.
8. Remove the adjustment lever.
9. Remove the cover fixing screws (Figure 5-44, Item 4).
10. Remove the cover.

### Note

Mark the polarity of the plug (Figure 5-44, Item 1), connected to the electronic unit.

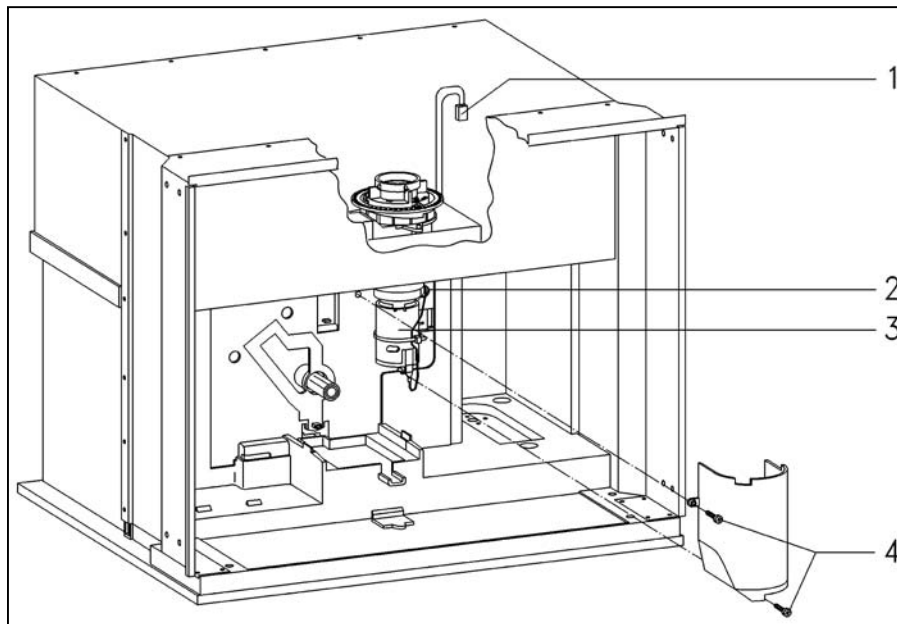

**Figure 5-44:** Accessing the grinder for complete removal

**Technical Information**

11. Remove the plug from the Electronic.
12. Lift the grinder upwards from the dampers (Figure 5-45, Item 2).

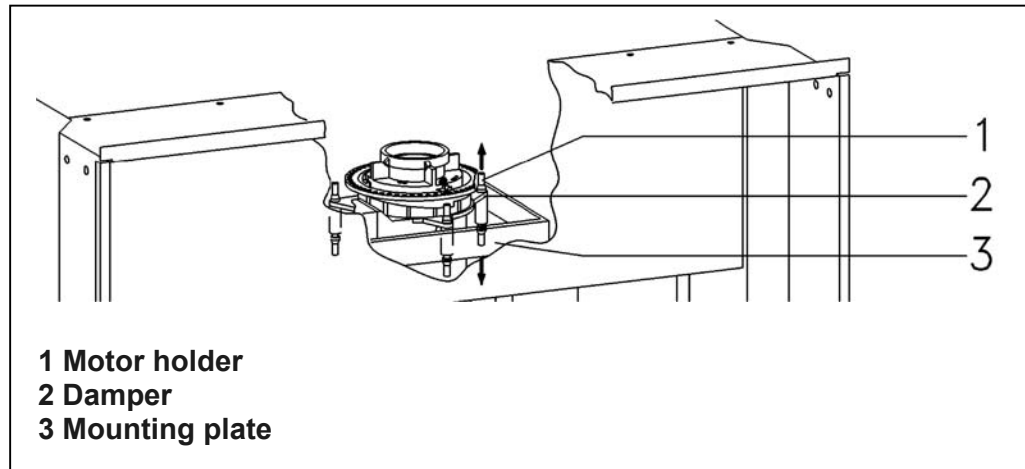

**Figure 5-45:** Grinder coupling

**Note**

When refitting the grinder, the dampers should be seated in the mounting plate and motor holder to ensure the grinder coupling is set to an optimal position and grinder noise is kept to a minimum.

## 5.42 Brew Unit Present Switch - removal

1. Remove the Top Lid.
2. Remove the Rear Panel.
3. Disconnect the switch (Figure 5-46, Item 2).
4. Press the retainers outward to remove the switch.

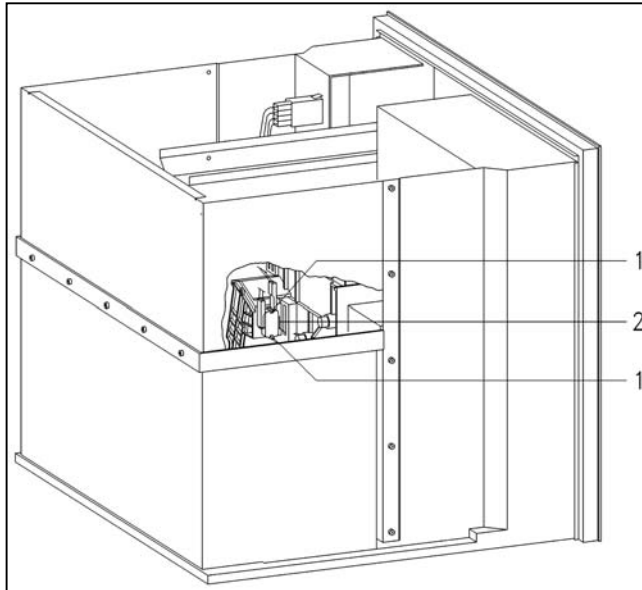

Figure 5-46: Brew unit present switch location and removal.

## 5.43 Dispensing Solenoid - Removal

1. Remove the Top Lid (5.1).
2. Remove the Rear Panel (5.3).
3. Remove the Beans Container (5.37).
4. Remove the Beans Container Guide (5.38).
5. Press the coil retainers outwards. Slide the coil upwards out of the guide.
6. Disconnect the coil connections.

## 5.44 Dispenser Switch - Removal

7. Remove the Top Lid (5.1).
8. Remove the Rear Panel (5.3).
9. Remove the Beans Container (5.37).
1. Remove the Beans Container Guide (5.38).
2. Remove the Dispensing Solenoid (5.34)
3. Press the switch retainers outwards. Remove the switch.
4. Disconnect the connections.

## Technical Information

**5.45 Brew Unit Drives – Home Positioning**

1. Remove the Brew Unit from the appliance.
2. Re-install the Waste Unit.
3. Close the door.
4. Turn the selector switch to one of the operating settings.
5. Allow the drives to reset into the home position.

**5.46 Waterpath / Flowmeter Check**

CAUTION: Hot Water will flow from the water spout during this procedure!

- 1) Fill the Water reservoir completely
- 2) Place the appliance into the Service Mode
- 3) Quickly turn the selector knob left to the "Programming" position
- 4) Press and hold all three coffee buttons -

The display will show the following...

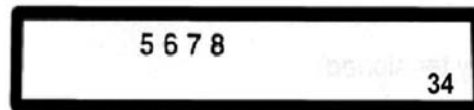

Does a pulsing (flickering) "8" appear in the first line of the display ?

NO

YES

The Flowmeter and the electronic are detecting the pulses from water moving through the water path (Normal Operating Conditions)  
Proceed to step 5

Does water flow from the hot water tube during the test ?

NO

YES

The water is not flowing through the water path - check for mechanical flow problems (obstructions) and that pump is operating.

- Unplug JP5 from the electronic.
- Place a jumper at JP5 between the rear & center pins on the electronic
- Place the unit into the Service Mode

Does the display show a solid "8" in the first line of the display ?

NO

YES

Replace the electronic

Replace the flowmeter

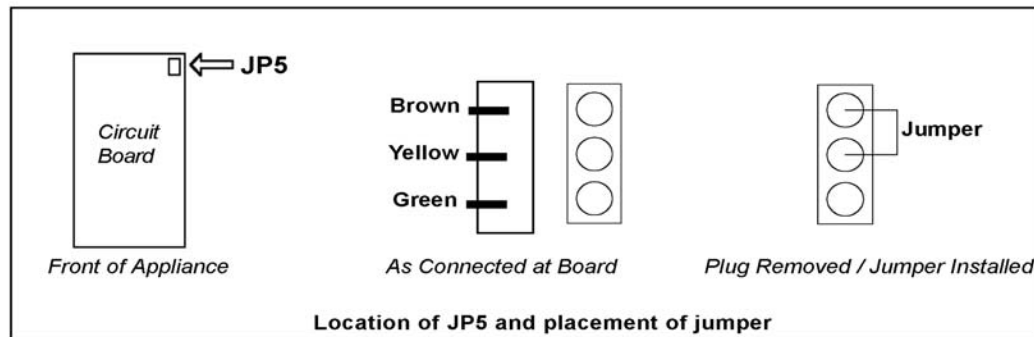

5) Release the three coffee buttons - Reconnect JP5 if disconnected earlier

During step 4...If water flowed from the hot water tube proceed to step 6.

If water did not flow from the hot water spout - correct problem before proceeding to step 6

6) Press the three coffee buttons again - observe the number displayed in the bottom right side of the display

**Is the displayed value 30 or higher ?**

**NO**

**Check...**

- Sufficient water is present
- Water path is clear of calcareous deposits
- Water lines are clear / not crimped etc..
- Heaters, flowmeter, filter etc...flow water
- Water valves fully open
- Water line connections don't leak

**YES**

The water path is clear and operating correctly

## 5.47 Water Path Leakage Test

Should water be present in bottom of the appliance (i.e. Watersystem Fault); or a leak is suspected the following procedure can be used to locate the source of the leak.

### Caution

The Heaters are hot during this test, and hot water under pressure could leak from the system.

1. Fill the Water Tank
2. Place the appliance into the Service Mode
3. Quickly turn the selector knob to the "Programming" position
4. Press and hold all three coffee buttons - check for signs of leakage (dripping, squirting etc...) hold buttons as long as necessary.
5. Release the three coffee buttons to end the test

## Technical Information

If the steps 1-5 do not disclose any leaks - continue as follows.

6. Fill the Water Tank
7. Place the appliance into the Service Mode
8. Quickly turn the selector knob to the "Operation" position
9. Press and hold all three coffee buttons for 30 seconds
10. Quickly turn the selector knob to the "Programming" position
11. Press and hold all three coffee buttons - check for signs of leakage (dripping, squirting etc...)
12. Release the three coffee buttons to end the test

## 5.48 Water Connections – Releasing

**Danger - Risk of burning or scalding!**

Components may be hot.

Pressurized Steam could exist in the system.

Before any service work is performed, allow time to cool.

Refer to Figure 5-47 below

1. Remove the retaining spring (Item 1).
2. Pull out the hose from the connector.
3. Remove the sealing rings (Item 2).

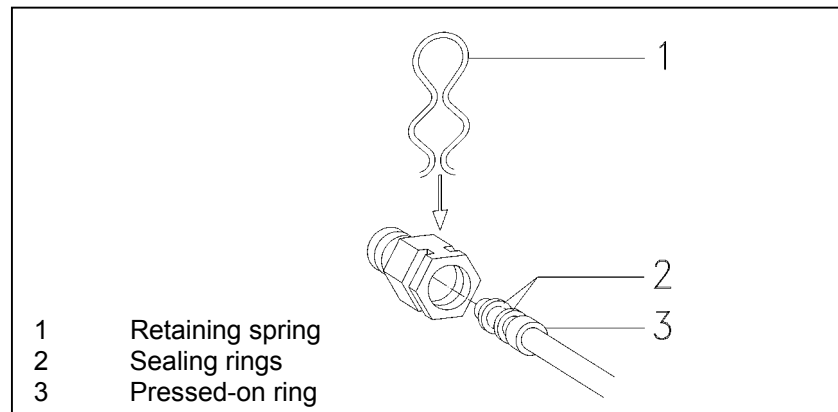

**Figure 5-47:** Water system connections with clip



**5.49 Water Connections - Fitting**

1. Check the Sealing Rings for damage - replace as necessary.
2. Fit the Sealing Rings on the hose.
3. Insert the Hose into the Connector.
4. Fit the Retaining Spring behind the Pressed-On Ring.
5. Ensure the Hose cannot be pulled from its Connector.

**Note**

The Pressed-On Rings cannot be replaced as a separate component. Should replacement be necessary the hose (as an assembly) must be replaced.

Technical Information

## 6. Fault Diagnosis

### 6.1 Programming Mode

The Programming Mode is available for access by the customer. The Programming Mode allows various options and / or features to be configured.

To access the Programming Mode, simply turn the selector knob to the "Program Mode" position

<b>Language</b>	German, Dutch, Portuguese, Spanish, English, Italian or French
<b>Rinsing</b>	on, off
<b>Water hardness</b>	hardness levels 1 to 4
<b>Temperature long coffee</b>	minimum, low, medium, high, maximum
<b>Temperature coffee</b>	minimum, low, medium, high, maximum
<b>Temperature short (espresso) coffee</b>	minimum, low, medium, high, maximum
<b>Pre-brewing</b>	on, off,
<b>Pre-grinding</b>	off, on
<b>Program hot water</b>	off, on
<b>Total coffee</b>	number of coffee servings
<b>Descaling</b>	automatic descaling program
<b>Standby timer</b>	to put unit in, selectable in 15 minute periods

Table 5-1: Programming Mode

## Technical Information

## 6.2 Service Mode

The Service Mode is used to check the status of various input switches and operate components in the appliance. The Service Mode is designed for accessed by qualified service personnel only.

### Initial requirements

- Switch off the appliance
- Ensure the front door is closed

### Access

1. Press and hold the SMALL COFFEE button and the HOT WATER button.
2. Refer to the Service Mode chart on the following page... turn the selector knob to the desired position.
3. Release the SMALL COFFEE and HOT WATER buttons.
4. Press the applicable button to activate the function listed.

### Acknowledgement Indicator

The following is an example indicates the appliance is in the Service Mode...

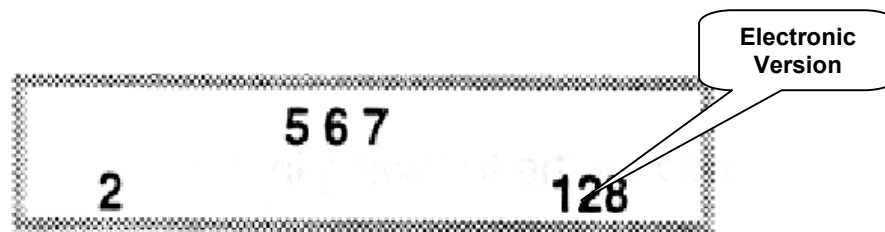

The display indicates the switches currently actuated.

1. Brewing position switch (brew unit drives)
2. Home position switch (brew unit drives)
3. Dispenser switch
4. Steam valve switch
5. Waste container present switch
6. Brew unit present switch
7. Water tank level switch
8. Flow meter pulse (not always displayed)
- A. Drip tray filled (water system fault)

**Service Mode - Navigation**

LOCK	Large Coffee	Displays Water Temperature for Water Heater and Steam Heater in Celsius.
	Med Coffee	Displays firmware version
	Small Coffee	(not used)
	Hot Water	(not used)
	Rinse	(not used)
PROGRAM MODE	Large Coffee	Water Pump ON
	Med Coffee	Steam Solenoid ON
	Small Coffee	Hot Water Valve ON
	Hot Water	Displays 5
	Rinse	Displays 4
LIGHT	Large Coffee	Button Test "1" displayed
	Med Coffee	Button Test "2" displayed
	Small Coffee	Button Test "3" displayed
	Hot Water	Button Test "5" displayed
	Rinse	Button Test "4" displayed
ON W/ LIGHT	Large Coffee	Drive motor ON till Brew Position Switch is contacted
	Med Coffee	Drive motor ON (reverse direction) till Home Switch is contacted
	Small Coffee	Grinder ON
	Hot Water	(not used)
	Rinse	Dispenser Solenoid ON
ON	Large Coffee	Hot Water / Coffee Side Heater Element ON
	Med Coffee	Hot Water / Coffee Upper Heater Element ON
	Small Coffee	Steam Heater Element ON
	Hot Water	Front Lights (CVA615)
	Rinse	(not used)

**Table 5-2:** Service Mode

Technical Information

**6.3 Displayed Messages**

<i>Displayed Message</i>	<i>Information</i>
<b>BREW UNIT BLOCKED</b>	<p>The brew unit is dirty. The brew unit is blocked. The brew unit is Jammed.</p> <ul style="list-style-type: none"> <li>• Clean / inspect brew unit / check drives</li> </ul>
<b>EXPEL AIR</b>	<p>Air is present with the water system –</p> <ul style="list-style-type: none"> <li>• Perform “Expel Air” procedure.</li> </ul>
<b>FILL COFFEE BEANS</b>	<p>The beans container is empty OR The grinder may be jammed.</p> <ul style="list-style-type: none"> <li>• Add coffee beans to the beans container.</li> <li>• Clean the conical grinder (top of grinder)</li> </ul>
<b>BREW UNIT MISSING</b>	<p>Brew unit is not installed OR Not installed correctly.</p> <ul style="list-style-type: none"> <li>• Reinstall the brew unit</li> <li>• Check brew unit present switch</li> </ul>
<b>DESCALING</b>	<ul style="list-style-type: none"> <li>• Perform the Descale Procedure.</li> </ul>
<b>WASTE UNIT MISSING</b>	<p>Waste unit is not installed OR the waste unit is not installed correctly</p> <ul style="list-style-type: none"> <li>• Re-install the waste unit</li> <li>• Check magnet on rear of waste unit</li> <li>• Check brew unit present switch</li> </ul>

**Table 5-3:** Displayed messages (continued on table 5-4)

<i>Displayed Message</i>	<i>Information</i>
<b>STANDBY...</b>	The appliance is in the energy saving <ul style="list-style-type: none"> <li>• Press ENTER</li> </ul>
<b>WATER SYSTEM FAULT</b>	The level switch has been actuated by water being present in the base of the appliance <ul style="list-style-type: none"> <li>• Clear unit of water from lower pan and locate / repair source of leak.</li> <li>• Check level switch for proper operation</li> </ul>
<b>FILL WATER TANK</b>	The water tank level switch is not actuated – water tank float is below the switch level <ul style="list-style-type: none"> <li>• Refill the water tank</li> <li>• Check that float and switch operate</li> </ul>
<b>EMPTY WATERTANK</b>	<ul style="list-style-type: none"> <li>• Check that flowmeter is plugged into the correct position of the electronic</li> </ul>
<b>WARMING UP...</b>	Appliance is warming up, as warming up the “...” in the display disappear

**Table 5-4:** Displayed messages (continued from table 5-3)

## Technical Information

**6.4 Uneven Filling - When two cups of coffee/espresso are being prepared at the same time**

1. Ensure the appliance is level – correct as necessary.
2. Clean the coffee nozzle.

**6.5 Brew Unit – Can't be removed from appliance**

The brew unit is not in the starting (home) position.

- Reset the brew unit to the starting (home) position via the service mode.

The brew unit is jammed and cannot be removed by resetting the appliance (i.e. shutting the door and turning on the power).

1. Perform the manual removal procedure.
2. Inspect the brew unit and/or drives to locate fault.

**6.6 Brew Unit – Can't be installed**

Ensure the handle section marked “PRESS” is pressed during installation of the Brew Unit. This area is only pressed during removal of the Brew Unit.

The brew unit is not in the starting (home position).

- Perform the “Brew Unit — manual resetting procedure (5.29).

The Drive Shaft is not in the starting (home) position.

1. Reset the brew unit to the starting (home) position via the service mode.
2. Inspect the Brew Unit and/or drives to locate fault (i.e. defective switch etc...)



## **6.7 Grinding Setting – Can't be set to a finer position (adjustment lever blocked)**

Check for ground coffee between the grinding ring and grinding cone. The ground coffee may have clogged the gap between the ring and cone.

1. Set the adjustment lever to the finest setting possible.
2. Prepare a coffee.
3. Set the adjustment lever to a finer setting.

Advise the customer the grinder should only be adjusted in small increments

Technical Information

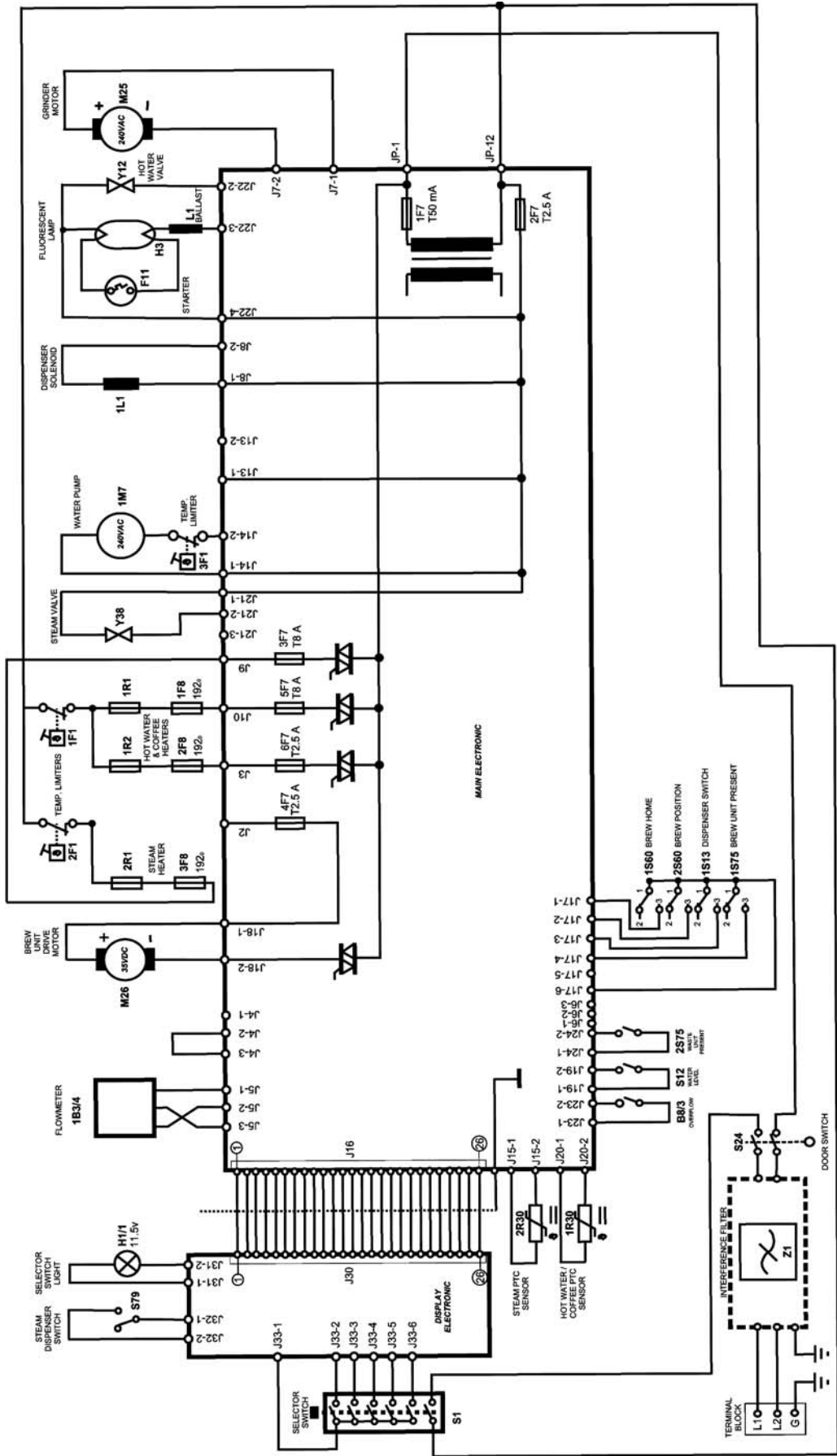

CVA-610  
U.S.A.