



C2750D4I

C2550D4I

# User Manual

Version 1.1

Published December 2013

Copyright©2013 ASRock Rack INC. All rights reserved.

---

## Copyright Notice:

No part of this manual may be reproduced, transcribed, transmitted, or translated in any language, in any form or by any means, except duplication of documentation by the purchaser for backup purpose, without written consent of ASRock Rack Inc.

Products and corporate names appearing in this manual may or may not be registered trademarks or copyrights of their respective companies, and are used only for identification or explanation and to the owners' benefit, without intent to infringe.

## Disclaimer:

Specifications and information contained in this manual are furnished for informational use only and subject to change without notice, and should not be constructed as a commitment by ASRock Rack. ASRock Rack assumes no responsibility for any errors or omissions that may appear in this manual.

With respect to the contents of this manual, ASRock Rack does not provide warranty of any kind, either expressed or implied, including but not limited to the implied warranties or conditions of merchantability or fitness for a particular purpose.

In no event shall ASRock Rack, its directors, officers, employees, or agents be liable for any indirect, special, incidental, or consequential damages (including damages for loss of profits, loss of business, loss of data, interruption of business and the like), even if ASRock Rack has been advised of the possibility of such damages arising from any defect or error in the manual or product.



This device complies with Part 15 of the FCC Rules. Operation is subject to the following two conditions:

- (1) this device may not cause harmful interference, and
- (2) this device must accept any interference received, including interference that may cause undesired operation.

## CALIFORNIA, USA ONLY

The Lithium battery adopted on this motherboard contains Perchlorate, a toxic substance controlled in Perchlorate Best Management Practices (BMP) regulations passed by the California Legislature. When you discard the Lithium battery in California, USA, please follow the related regulations in advance.

“Perchlorate Material-special handling may apply, see

[www.dtsc.ca.gov/hazardouswaste/perchlorate](http://www.dtsc.ca.gov/hazardouswaste/perchlorate)”

**ASRock Rack Website:** <http://www.asrock.com>

---

# Contents

|  |           |
|--|-----------|
| <b>1 Introduction .....</b>                      | <b>5</b>  |
| 1.1 Package Contents.....                        | 5         |
| 1.2 Specifications.....                          | 6         |
| 1.3 Unique Features.....                         | 12        |
| 1.4 Motherboard Layout.....                      | 13        |
| 1.5 I/O Panel .....                              | 17        |
| 1.6 Block Diagram.....                           | 18        |
| <b>2 Installation .....</b>                      | <b>19</b> |
| 2.1 Pre-installation Precautions .....           | 19        |
| 2.2 Screw Holes.....                             | 19        |
| 2.3 Installation of Memory Modules (DIMM) .....  | 20        |
| 2.4 Expansion Slots .....                        | 22        |
| 2.5 Jumpers Setup .....                          | 23        |
| 2.6 Onboard Headers and Connectors .....         | 24        |
| 2.7 Driver Installation Guide.....               | 30        |
| <b>3 UEFI SETUP UTILITY.....</b>                 | <b>31</b> |
| 3.1 Introduction .....                           | 31        |
| 3.1.1 UEFI Menu Bar.....                         | 31        |
| 3.1.2 Navigation Keys .....                      | 32        |
| 3.2 Main Screen.....                             | 33        |
| 3.3 Advanced Screen.....                         | 34        |
| 3.3.1 Storage Configuration .....                | 35        |
| 3.3.2 ACPI Configuration.....                    | 36        |
| 3.3.3 Super IO Configuration.....                | 37        |
| 3.3.4 Serial Port Console Redirection .....      | 38        |
| 3.3.5 PCI Subsystem Settings.....                | 39        |
| 3.3.6 PLX 8608 Configuration .....               | 40        |
| 3.3.7 Voltage .....                              | 41        |
| 3.4 Hardware Health Event Monitoring Screen..... | 42        |
| 3.5 Intel RCSetup.....                           | 43        |
| 3.5.1 Processor Configuration.....               | 44        |
| 3.5.2 Clock Generation Configuration .....       | 46        |
| 3.5.3 North Bridge Chipset Configuration.....    | 47        |
| 3.5.4 South Bridge Chipset Configuration .....   | 48        |
| 3.5.5 System Event Log .....                     | 50        |

---

|          |   |           |
|----------|---|-----------|
| 3.6      | Server Management.....                        | 51        |
| 3.7      | Event Logs .....                              | 52        |
| 3.8      | Security Screen.....                          | 53        |
| 3.9      | Boot Screen .....                             | 54        |
| 3.10     | Exit Screen.....                              | 55        |
| <b>4</b> | <b>Software Support .....</b>                 | <b>56</b> |
| 4.1      | Install Operating System.....                 | 56        |
| 4.2      | Support CD Information .....                  | 56        |
| 4.2.1    | Running Support CD .....                      | 56        |
| 4.2.2    | Drivers Menu.....                             | 56        |
| 4.2.3    | Utilities Menu.....                           | 56        |
| 4.2.4    | Contact Information .....                     | 56        |
| <b>5</b> | <b>Troubleshooting .....</b>                  | <b>57</b> |
| 5.1      | Troubleshooting Procedures .....              | 57        |
| 5.2      | Technical Support Procedures .....            | 59        |
| 5.3      | Returning Merchandise for Service.....        | 59        |
| <b>6</b> | <b>Net Framework Installation Guide .....</b> | <b>60</b> |

---

# Chapter 1: Introduction

Thank you for purchasing ASRock Rack **C2750D4I / C2550D4I** motherboard, a reliable motherboard produced under ASRock Rack's consistently stringent quality control. It delivers excellent performance with robust design conforming to ASRock Rack's commitment to quality and endurance. In this manual, chapter 1 and 2 contains the introduction of the motherboard and step-by-step hardware installation guide. Chapter 3 and 4 contains the configuration guide of BIOS setup and information of the Support CD.



Because the motherboard specifications and the BIOS software might be updated, the content of this manual will be subject to change without notice. In case any modifications of this manual occur, the updated version will be available on ASRock Rack's website without further notice. You may find the latest VGA cards and CPU support list on ASRock Rack's website as well. ASRock Rack website <http://www.asrock.com>  
If you require technical support related to this motherboard, please visit our website for specific information about the model you are using.  
[www.asrock.com/support/index.asp](http://www.asrock.com/support/index.asp)

## 1.1 Package Contents

ASRock Rack **C2750D4I / C2550D4I** Motherboard  
(Mini-ITX Form Factor: 6.7-in x 6.7-in, 17.0 cm x 17.0 cm)  
1 x User Manual  
1 x Support CD  
6 x Serial ATA (SATA) Data Cables (Optional)  
1 x I/O Panel Shield

---

## 1.2 Specifications

### C2750D4I

|                         |                            |  |
|-------------------------|----------------------------|--|
| <b>Physical Status</b>  | Form Factor                | Mini-ITX   |
|                         | Dimension                  | 6.7" x 6.7" (17.0 cm x 17.0 cm)  |
| <b>Processor System</b> | CPU                        | Intel® Octa Core Avoton C2750 Processor  |
|                         | Socket                     | FCBGA1283 SOC  |
| <b>System Memory</b>    | Max. Capacity              | 64GB DDR3 ECC UDIMM  |
|                         | Socket                     | - 4 x 240-pin DDR3 DIMM slots<br>- Support up to 64GB DDR3 ECC and UDIMM   |
|                         | Type                       | - Dual Channel DDR3 memory technology<br>- Supports DDR3 1600/1333 ECC and UDIMM   |
|                         | Voltage                    | 1.5V, 1.35V  |
| <b>Expansion Slot</b>   | PCIe 2.0 x 8               | 1 slot (x8 mode)   |
| <b>Storage</b>          | SATA Controller            | Intel® C2750 : 2 x SATA3 6.0 Gb/s, 4 x SATA2 3.0 Gb/s  |
|                         | Additional SATA Controller | - Marvell SE9172: 2 x SATA3 6.0 Gb/s<br>- Marvell SE9230: 4 x SATA3 6.0 Gb/s   |
| <b>Ethernet</b>         | Interface                  | Gigabit LAN 10/100/1000 Mb/s   |
|                         | LAN Controller             | - 2 x Intel® i210<br>- Supports Wake-On-LAN<br>- Supports Energy Efficient Ethernet 802.3az<br>- Supports Dual LAN with Teaming function<br>- Supports PXE |

|                           |                        |   |
|---------------------------|------------------------|---|
| <b>Management</b>         | BMC Controller         | ASPEED AST2300 : IPMI (Intelligent Platform Management Interface) 2.0 with iKVM support   |
|                           | IPMI Dedicated GLAN    | 1 x Realtek RTL8211E for dedicated management GLAN  |
|                           | Features               | - Watch Dog<br>- NMI  |
| <b>Graphics</b>           | Controller             | ASPEED AST2300  |
|                           | VRAM                   | DDR3 16MB   |
|                           | Output                 | Supports D-Sub with max. resolution up to 1920x1200 @ 60Hz  |
| <b>Rear Panel I/O</b>     | VGA Port               | 1 x D-Sub   |
|                           | USB 2.0 Port           | 2   |
|                           | LAN Port               | - 2 x RJ45 Gigabit Ethernet LAN ports<br>- 1 x RJ45 Dedicated IPMI LAN port<br>- LAN Ports with LED (ACT/LINK LED and SPEED LED)                          |
|                           | Serial Port            | 1 (COM1)  |
|                           | UID Button/<br>UID LED | 1   |
| <b>Internal Connector</b> | Auxiliary Panel Header | 1 (includes location button & LED, front LAN LED)   |
|                           | IPMB Header            | 1   |
|                           | Fan Header             | 6 x 4-pin   |
|                           | ATX Power              | 1 (24-pin)  |
|                           | USB 2.0 Header         | 1 (support 1 via headers or 2 via headers controlled by USB_SEL1 and USB_SEL2 jumper)   |
|                           | Front Panel            | 1   |
| <b>System BIOS</b>        | BIOS Type              | 64Mb AMI UEFI Legal BIOS  |
|                           | BIOS Features          | - Plug and Play (PnP)<br>- ACPI 1.1 Compliance Wake Up Events<br>- SMBIOS 2.3.1 Support<br>- DRAM Voltage Multi-adjustment<br>- ASRock Rack Instant Flash |

|                         |             |   |
|-------------------------|-------------|---|
| <b>Hardware Monitor</b> | Temperature | - CPU Temperature Sensing<br>- Motherboard Temperature Sensing  |
|                         | Fan         | - CPU/Rear/Front Fan Tachometer<br>- CPU Quiet Fan (Allow CPU Fan Speed Auto-Adjust by CPU Temperature)<br>- CPU/Rear/Front Fan Multi-Speed Control   |
|                         | Voltage     | Voltage Monitoring: +12V, +5V, +3.3V, CPU Vcore, DRAM, +1.1V, +1.0V, +BAT, 3VSB, 5VSB   |
| <b>Supported OS</b>     | OS          | Microsoft® Windows®:<br>Server 2008 R2 SP1(x64)<br>Server 2012 (x64)<br>Linux:<br>CentOS 6.4/5.10 (x32 and x64) (only support AHCI mode)<br>SUSE Enterprise Linux Server 11 SP1 (x32 and x64)<br>FreeBSD 9.1 (x32 and x64)<br>Fedora Core 19 (x64)<br>UBuntu 12.04/12.10 (x64)<br>Virtual:<br>VMWare ESXi 5.5 |
| <b>Environment</b>      | Temperature | Operation temperature: 10°C ~ 35°C<br>/ Non operation temperature: -40°C ~ 70°C   |

\* For detailed product information, please visit our website: <http://www.asrock.com>



Since Intel® Edisonville platform does not support RSTe feature, it is decided by OS inbox driver behavior.

The Avoton processor integrated I/O's SATA2/3 driver is used inbox not Intel®. So according to Windows® 2008 R2 OS operation behaviors, it needs to take about ~60sec refresh timer when users unplug SATA device.

You have to go in manually to detect the drive and recognize it.

In other words, the operation system will quickly response the SATA plug in/out status about ~10sec when users install the RSTe driver if the platform supports it.



---

## C2550D4I

|                         |                            |  |
|-------------------------|----------------------------|--|
| <b>Physical Status</b>  | Form Factor                | Mini-ITX   |
|                         | Dimension                  | 6.7" x 6.7" (17.0 cm x 17.0 cm)  |
| <b>Processor System</b> | CPU                        | Intel® Quad-Core Avoton C2550 Processor  |
|                         | Socket                     | FCBGA1283 SOC  |
| <b>System Memory</b>    | Max. Capacity              | 64GB DDR3 ECC UDIMM  |
|                         | Socket                     | - 4 x 240-pin DDR3 DIMM slots<br>- Support up to 64GB DDR3 ECC and UDIMM   |
|                         | Type                       | - Dual Channel DDR3 memory technology<br>- Supports DDR3 1600/1333 ECC and UDIMM   |
|                         | Voltage                    | 1.5V, 1.35V  |
| <b>Expansion Slot</b>   | PCIe 2.0 x 8               | 1 slot (x8 mode)   |
| <b>Storage</b>          | SATA Controller            | Intel® C2550 : 2 x SATA3 6.0 Gb/s, 4 x SATA2 3.0 Gb/s  |
|                         | Additional SATA Controller | - Marvell SE9172: 2 x SATA3 6.0 Gb/s<br>- Marvell SE9230: 4 x SATA3 6.0 Gb/s   |
| <b>Ethernet</b>         | Interface                  | Gigabit LAN 10/100/1000 Mb/s   |
|                         | LAN Controller             | - 2 x Intel® i210<br>- Supports Wake-On-LAN<br>- Supports Energy Efficient Ethernet 802.3az<br>- Supports Dual LAN with Teaming function<br>- Supports PXE |

|                       |                           |   |
|-----------------------|---------------------------|---|
| <b>Management</b>     | BMC Controller            | ASPEED AST2300 : IPMI (Intelligent Platform Management Interface) 2.0 with iKVM support   |
|                       | IPMI Dedicated GLAN       | 1 x Realtek RTL8211E for dedicated management GLAN  |
|                       | Features                  | - Watch Dog<br>- NMI  |
| <b>Graphics</b>       | Controller                | ASPEED AST2300  |
|                       | VRAM                      | DDR3 16MB   |
|                       | Output                    | Supports D-Sub with max. resolution up to 1920x1200 @ 60Hz  |
| <b>Rear Panel I/O</b> | VGA Port                  | 1 x D-Sub   |
|                       | USB 2.0 Port              | 2   |
|                       | LAN Port                  | - 2 x RJ45 Gigabit Ethernet LAN ports<br>- 1 x RJ45 Dedicated IPMI LAN port<br>- LAN Ports with LED (ACT/LINK LED and SPEED LED)                          |
|                       | Serial Port               | 1 (COM1)  |
|                       | UID Button/<br>UID LED    | 1   |
|                       | <b>Internal Connector</b> | Auxiliary Panel Header  |
| IPMB Header           |                           | 1   |
| Fan Header            |                           | 6 x 4-pin   |
| ATX Power             |                           | 1 (24-pin)  |
| USB 2.0 Header        |                           | 1 (support 1 via headers or 2 via headers controlled by USB_SEL1 and USB_SEL2 jumper)   |
| Front Panel           |                           | 1   |
| <b>System BIOS</b>    | BIOS Type                 | 64Mb AMI UEFI Legal BIOS  |
|                       | BIOS Features             | - Plug and Play (PnP)<br>- ACPI 1.1 Compliance Wake Up Events<br>- SMBIOS 2.3.1 Support<br>- DRAM Voltage Multi-adjustment<br>- ASRock Rack Instant Flash |

|                         |             |   |
|-------------------------|-------------|---|
| <b>Hardware Monitor</b> | Temperature | - CPU Temperature Sensing<br>- Motherboard Temperature Sensing  |
|                         | Fan         | - CPU/Rear/Front Fan Tachometer<br>- CPU Quiet Fan (Allow CPU Fan Speed Auto-Adjust by CPU Temperature)<br>- CPU/Rear/Front Fan Multi-Speed Control   |
|                         | Voltage     | Voltage Monitoring: +12V, +5V, +3.3V, CPU Vcore, DRAM, +1.1V, +1.0V, +BAT, 3VSB, 5VSB   |
| <b>Supported OS</b>     | OS          | Microsoft® Windows®:<br>Server 2008 R2 SP1(x64)<br>Server 2012 (x64)<br>Linux:<br>CentOS 6.4/5.10 (x32 and x64) (only support AHCI mode)<br>SUSE Enterprise Linux Server 11 SP1 (x32 and x64)<br>FreeBSD 9.1 (x32 and x64)<br>Fedora Core 19 (x64)<br>UBuntu 12.04/12.10 (x64)<br>Virtual:<br>VMWare ESXi 5.5 |
| <b>Environment</b>      | Temperature | Operation temperature: 10°C ~ 35°C<br>/ Non operation temperature: -40°C ~ 70°C   |

\* For detailed product information, please visit our website: <http://www.asrock.com>



Since Intel® Edisonville platform does not support RSTe feature, it is decided by OS inbox driver behavior.

The Avoton processor integrated I/O's SATA2/3 driver is used inbox not Intel®. So according to Windows® 2008 R2 OS operation behaviors, it needs to take about ~60sec refresh timer when users unplug SATA device.

You have to go in manually to detect the drive and recognize it.

In other words, the operation system will quickly response the SATA plug in/out status about ~10sec when users install the RSTe driver if the platform supports it.

---

## 1.3 Unique Features

### **Instant Flash**

Instant Flash is a BIOS flash utility embedded in Flash ROM. This convenient BIOS update tool allows you to update your BIOS without entering operating systems first like MS-DOS or Windows®. With this utility, you can press the <F6> key during the POST or the <F2> key to enter into the BIOS setup menu to access Instant Flash. Just launch this tool and save the new BIOS file to your USB flash drive, floppy disk or hard drive, then you can update your BIOS only in a few clicks without preparing an additional floppy diskette or other complicated flash utility. Please be noted that the USB flash drive or hard drive must use FAT32/16/12 file system.

# 1.4 Motherboard Layout

## C2750D4I

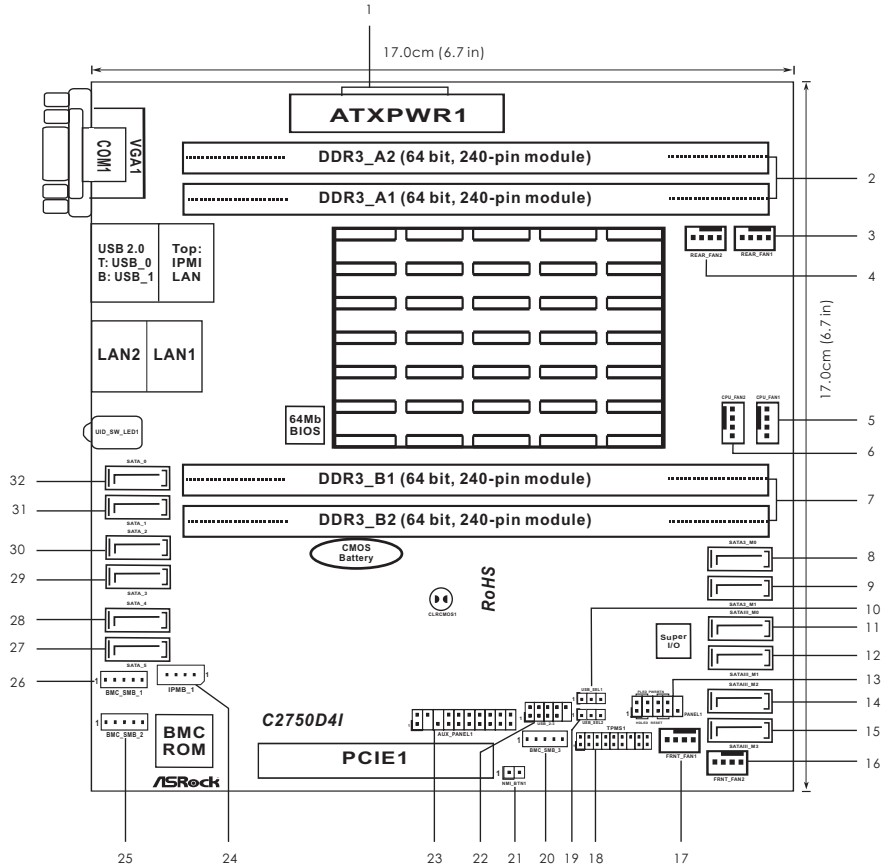

---

|    |   |
|----|---|
| 1  | ATX Power Connector (ATXPWR1)                       |
| 2  | 2 x 240-pin DDR3 DIMM Slots (DDR3_A1, DDR3_A2)      |
| 3  | Rear Fan Connector (REAR_FAN1)                      |
| 4  | Rear Fan Connector (REAR_FAN2)                      |
| 5  | CPU Fan Connector (CPU_FAN1)                        |
| 6  | CPU Fan Connector (CPU_FAN2)                        |
| 7  | 2 x 240-pin DDR3 DIMM Slots (DDR3_B1, DDR3_B2)      |
| 8  | SATA3 Connector (SATA3_M0, White)                   |
| 9  | SATA3 Connector (SATA3_M1, White)                   |
| 10 | USB Selection Jumper (USB_SEL1)                     |
| 11 | SATA3 Connector (SATAIII_M0, White)                 |
| 12 | SATA3 Connector (SATAIII_M1, White)                 |
| 13 | System Panel Header (PANEL1)                        |
| 14 | SATA3 Connector (SATAIII_M2, White)                 |
| 15 | SATA3 Connector (SATAIII_M3, White)                 |
| 16 | Front Fan Connector (FRNT_FAN2)                     |
| 17 | Front Fan Connector (FRNT_FAN1)                     |
| 18 | TPM Header (TPMS1)                                  |
| 19 | USB Selection Jumper (USB_SEL2)                     |
| 20 | BMC SMB Header (BMC_SMB3)                           |
| 21 | Non Maskable Interrupt Button (NMI_BTN1)            |
| 22 | USB 2.0 Header (USB_2-3)                            |
| 23 | Auxiliary Panel Header (AUX_PANEL1)                 |
| 24 | Intelligent Platform Management Bus header (IPMB_1) |
| 25 | BMC SMB Header (BMC_SMB2)                           |
| 26 | BMC SMB Header (BMC_SMB1)                           |
| 27 | SATA2 Connector (SATA_5, Blue)                      |
| 28 | SATA2 Connector (SATA_4, Blue)                      |
| 29 | SATA2 Connector (SATA_3, Blue)                      |
| 30 | SATA2 Connector (SATA_2, Blue)                      |
| 31 | SATA3 Connector (SATA_1, White)                     |
| 32 | SATA3 Connector (SATA_0, White)                     |

---

# C2550D4I

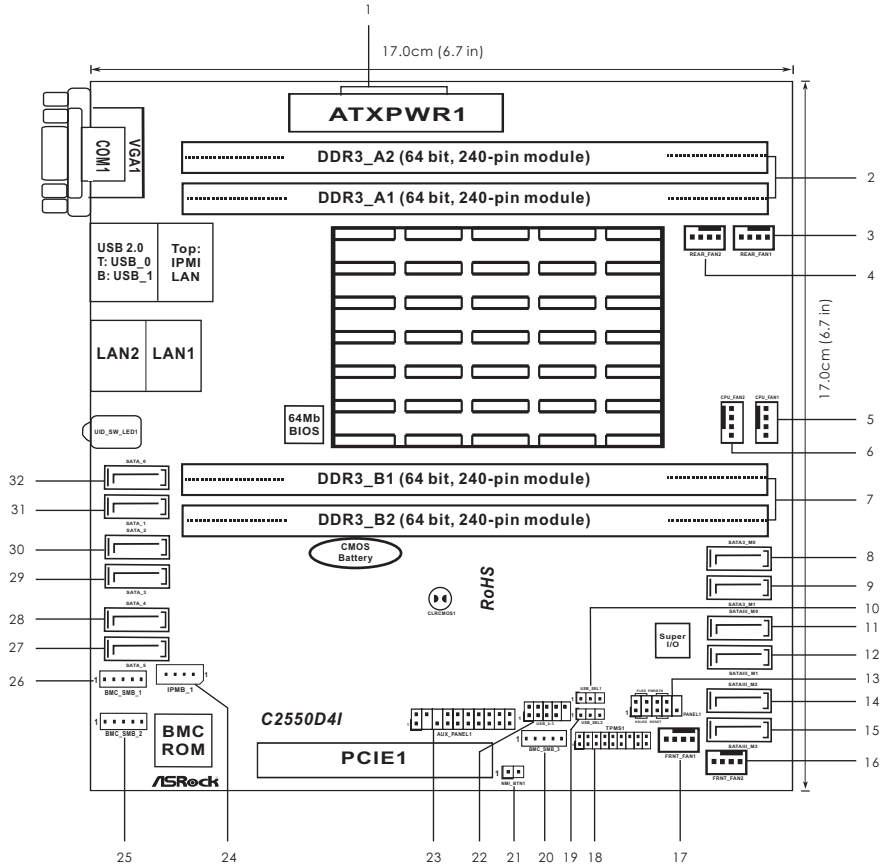

---

|    |   |
|----|---|
| 1  | ATX Power Connector (ATXPWR1)                       |
| 2  | 2 x 240-pin DDR3 DIMM Slots (DDR3_A1, DDR3_A2)      |
| 3  | Rear Fan Connector (REAR_FAN1)                      |
| 4  | Rear Fan Connector (REAR_FAN2)                      |
| 5  | CPU Fan Connector (CPU_FAN1)                        |
| 6  | CPU Fan Connector (CPU_FAN2)                        |
| 7  | 2 x 240-pin DDR3 DIMM Slots (DDR3_B1, DDR3_B2)      |
| 8  | SATA3 Connector (SATA3_M0, White)                   |
| 9  | SATA3 Connector (SATA3_M1, White)                   |
| 10 | USB Selection Jumper (USB_SEL1)                     |
| 11 | SATA3 Connector (SATAIII_M0, White)                 |
| 12 | SATA3 Connector (SATAIII_M1, White)                 |
| 13 | System Panel Header (PANEL1)                        |
| 14 | SATA3 Connector (SATAIII_M2, White)                 |
| 15 | SATA3 Connector (SATAIII_M3, White)                 |
| 16 | Front Fan Connector (FRNT_FAN2)                     |
| 17 | Front Fan Connector (FRNT_FAN1)                     |
| 18 | TPM Header (TPMS1)                                  |
| 19 | USB Selection Jumper (USB_SEL2)                     |
| 20 | BMC SMB Header (BMC_SMB3)                           |
| 21 | Non Maskable Interrupt Button (NMI_BTN1)            |
| 22 | USB 2.0 Header (USB_2-3)                            |
| 23 | Auxiliary Panel Header (AUX_PANEL1)                 |
| 24 | Intelligent Platform Management Bus header (IPMB_1) |
| 25 | BMC SMB Header (BMC_SMB2)                           |
| 26 | BMC SMB Header (BMC_SMB1)                           |
| 27 | SATA2 Connector (SATA_5, Blue)                      |
| 28 | SATA2 Connector (SATA_4, Blue)                      |
| 29 | SATA2 Connector (SATA_3, Blue)                      |
| 30 | SATA2 Connector (SATA_2, Blue)                      |
| 31 | SATA3 Connector (SATA_1, White)                     |
| 32 | SATA3 Connector (SATA_0, White)                     |

---



## 1.5 I/O Panel

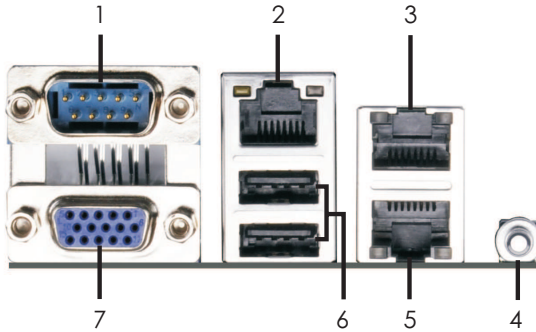

- 1 Serial Port (COM1)
- 2 Dedicated IPMI LAN Port\*
- 3 LAN RJ-45 Port (LAN1)\*\*
- 4 UID Switch/LED (UID\_SW\_LED1)
- 5 LAN RJ-45 Port (LAN2)\*\*
- 6 USB 2.0 Ports (USB\_0-1)
- 7 D-Sub Port (VGA1)

\* There are two LEDs on each LAN port. Please refer to the table below for the LAN port LED indications.

| Dedicated IPMI LAN Port LED Indications |                    |           |                    |
|---|--------------------|-----------|--------------------|
| Activity/Link LED                       |                    | SPEED LED |                    |
| Status                                  | Description        | Status    | Description        |
| Off                                     | No Link            | Off       | 10Mbps connection  |
| Blinking                                | Data Activity      | Orange    | 100Mbps connection |
| On                                      | 100Mbps connection | Green     | 1Gbps connection   |

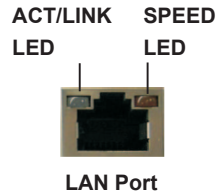

\*\* There are two LEDs on each LAN port. Please refer to the table below for the LAN port LED indications.

| LAN Port (LAN1, LAN2) LED Indications |                    |           |                    |
|---------------------------------------|--------------------|-----------|--------------------|
| Activity/Link LED                     |                    | SPEED LED |                    |
| Status                                | Description        | Status    | Description        |
| Off                                   | No Link            | Off       | 10Mbps connection  |
| Blinking                              | Data Activity      | Off       | 100Mbps connection |
| On                                    | 100Mbps connection | Green     | 1Gbps connection   |

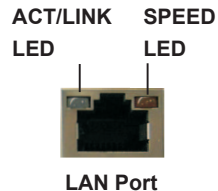

# 1.6 Block Diagram

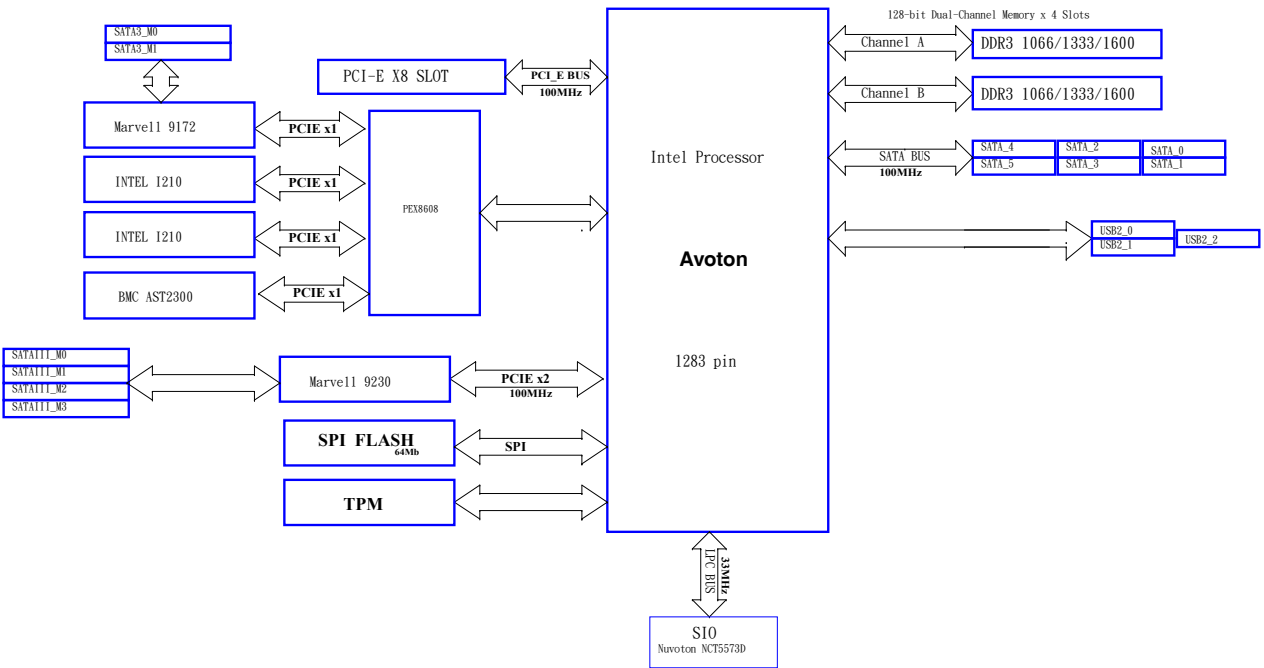

---

## **Chapter 2: Installation**

Before you install the motherboard, study the configuration of your chassis to ensure that the motherboard fits into it.

### **2.1 Pre-installation Precautions**

Take note of the following precautions before you install motherboard components or change any motherboard settings.

1. Make sure to unplug the power cord before installing or removing the motherboard. Failure to do so may cause physical injuries to you and damages to motherboard components.
2. In order to avoid damage from static electricity to the motherboard's components, NEVER place your motherboard directly on a carpet. Also remember to use a grounded wrist strap or touch a safety grounded object before you handle the components.
3. Hold components by the edges and do not touch the ICs.
4. Whenever you uninstall any components, place them on a grounded anti-static pad or in the bag that comes with the components.
5. When placing screws to secure the motherboard to the chassis, please do not over-tighten the screws! Doing so may damage the motherboard.

### **2.2 Screw Holes**

Place screws into the holes indicated by circles to secure the motherboard to the chassis.

---

## 2.3 Installation of Memory Modules (DIMM)

This motherboard provides four 240-pin DDR3 (Double Data Rate 3) DIMM slots, and supports Dual Channel Memory Technology.



1. For dual channel configuration, you always need to install identical (the same brand, speed, size and chip-type) DDR3 DIMM pairs.
2. It is unable to activate Dual Channel Memory Technology with only one or three memory module installed.
3. It is not allowed to install a DDR or DDR2 memory module into a DDR3 slot; otherwise, this motherboard and DIMM may be damaged.
4. Please install the memory module on DDR3\_A1 for the first priority.

### Dual Channel Memory Configuration

| Priority | DDR3_A1<br>(Blue) | DDR3_A2<br>(White) | DDR3_B1<br>(Blue) | DDR3_B2<br>(White) |
|----------|-------------------|--------------------|-------------------|--------------------|
| 1        | Populated         |                    | Populated         |                    |
| 2        | Populated         | Populated          | Populated         | Populated          |



The DIMM only fits in one correct orientation. It will cause permanent damage to the motherboard and the DIMM if you force the DIMM into the slot at incorrect orientation.

---

1

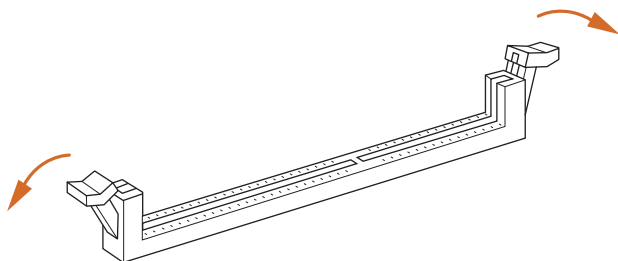

2

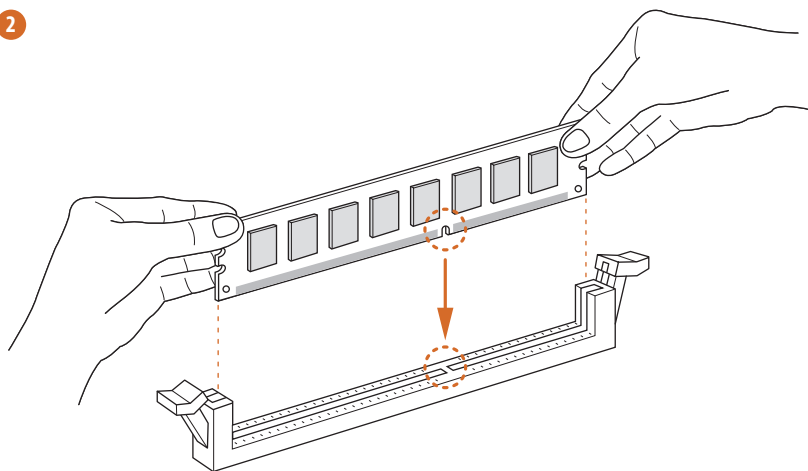

3

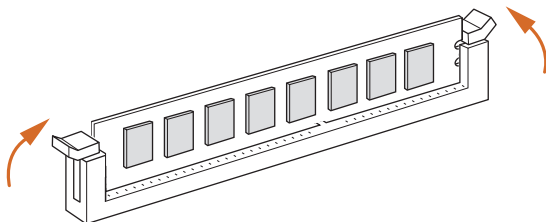

---

## 2.4 Expansion Slot (PCI Express Slot)

There is 1 PCI Express slot on the motherboard.

### **PCIe slot:**

PCIe1 (PCIe 2.0 x8 slot) is used for PCI Express x8 lane width graphics cards.

### **Installing an expansion card**

- Step 1. Before installing an expansion card, please make sure that the power supply is switched off or the power cord is unplugged. Please read the documentation of the expansion card and make necessary hardware settings for the card before you start the installation.
- Step 2. Remove the system unit cover (if your motherboard is already installed in a chassis).
- Step 3. Remove the bracket facing the slot that you intend to use. Keep the screws for later use.
- Step 4. Align the card connector with the slot and press firmly until the card is completely seated on the slot.
- Step 5. Fasten the card to the chassis with screws.
- Step 6. Replace the system cover.

---

## 2.5 Jumpers Setup

The illustration shows how jumpers are setup. When the jumper cap is placed on pins, the jumper is “Short”. If no jumper cap is placed on pins, the jumper is “Open”. The illustration shows a 3-pin jumper whose pin1 and pin2 are “Short” when jumper cap is placed on these 2 pins.

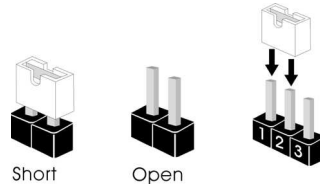

---

### USB Selection Jumpers

(3-pin USB\_SEL1)  
(see p.13 or 15, No. 10)

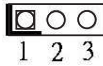

**1-2:**

Default

**2-3:**

USB Selection

(3-pin USB\_SEL2)  
(see p.13 or 15, No. 19)

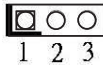

Support 2 via rear USB2 ports and 1 via front USB headers controlled by USB\_SEL1:1-2 and USB\_SEL2:1-2  
Support 1 via rear USB2 ports and 2 via front USB headers controlled by USB\_SEL1:2-3 and USB\_SEL2:2-3

---

## 2.6 Onboard Headers and Connectors



Onboard headers and connectors are NOT jumpers. Do NOT place jumper caps over these headers and connectors. Placing jumper caps over the headers and connectors will cause permanent damage to the motherboard!

---

### Serial ATA3 Connectors

(SATA\_0:

see p.13 or 15, No. 32)



SATA\_0



SATA3\_M0

(SATA\_1:

see p.13 or 15, No. 31)



SATA\_1



SATA3\_M1

(SATA3\_M0:

see p.13 or 15, No. 8)

(SATA3\_M1:

see p.13 or 15, No. 9)

(SATAIII\_M0:

see p.13 or 15, No. 11)

(SATAIII\_M1:

see p.13 or 15, No. 12)

(SATAIII\_M2:

see p.13 or 15, No. 14)

(SATAIII\_M3:

see p.13 or 15, No. 15)



SATAIII\_M0



SATAIII\_M1



SATAIII\_M2



SATAIII\_M3

These eight Serial ATA3

(SATA3) connectors support SATA data cables for internal storage devices.

The current SATA3 interface allows up to 6.0 Gb/s data transfer rate.

---

### Serial ATA2 Connectors

(SATA\_2:

see p.13 or 15, No. 30)

(SATA\_3:

see p.13 or 15, No. 29)

(SATA\_4:

see p.13 or 15, No. 28)

(SATA\_5:

see p.13 or 15, No. 27)



SATA\_2



SATA\_3



SATA\_4



SATA\_5

These four Serial ATA2

(SATA2) connectors support SATA data cables for internal storage devices.

The current SATA2 interface allows up to 3.0 Gb/s data transfer rate.



---

## USB 2.0 Header

(9-pin USB\_2-3)

(see p.13 or 15, No. 22)

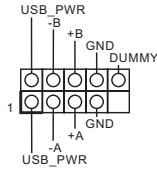

Besides two default USB 2.0 ports on the I/O panel, there is one USB 2.0 header on this motherboard. Each USB 2.0 header can support two USB 2.0 ports.

---

## TPM Header

(17-pin TPMS1)

(see p.13 or 15, No. 18)

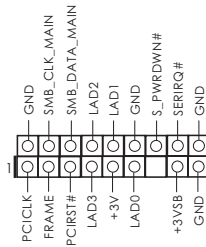

This connector supports Trusted Platform Module (TPM) system, which can securely store keys, digital certificates, passwords, and data. A TPM system also helps enhance network security, protects digital identities, and ensures platform integrity.

---

## System Panel Header

(9-pin PANEL1)

(see p.13 or 15, No. 13)

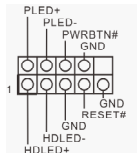

This header accommodates several system front panel functions.



Connect the power switch, reset switch and system status indicator on the chassis to this header according to the pin assignments below. Note the positive and negative pins before connecting the cables.

### **PWRBTN (Power Switch):**

Connect to the power switch on the chassis front panel. You may configure the way to turn off your system using the power switch.

### **RESET (Reset Switch):**

Connect to the reset switch on the chassis front panel. Press the reset switch to restart the computer if the computer freezes and fails to perform a normal restart.

### PLED (System Power LED):

Connect to the power status indicator on the chassis front panel. The LED is on when the system is operating. The LED keeps blinking when the system is in S3 sleep state. The LED is off when the system is in powered off (S5).

### HDLED (Hard Drive Activity LED):

Connect to the hard drive activity LED on the chassis front panel. The LED is on when the hard drive is reading or writing data.

The front panel design may differ by chassis. A front panel module mainly consists of power switch, reset switch, power LED, hard drive activity LED and etc. When connecting your chassis front panel module to this header, make sure the wire assignments and the pin assignments are matched correctly.

## Auxiliary Panel Header

(18-pin AUX\_PANEL1)  
(see p.13 or 15, No. 14)

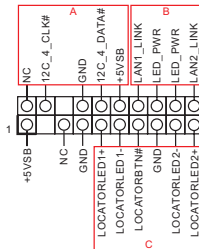

This header supports multiple functions on the front panel, including front panel SMB, internet status indicator.



### A. Front panel SMBus connecting pin (6-pin FPSMB)

This header allows you to connect SMBus (System Management Bus) equipment. It can be used for communication between peripheral equipment in the system, which has slower transmission rates, and power management equipment.

### B. Internet status indicator (2-pin LAN1\_LED, LAN2\_LED)

These two 2-pin headers allow you to use the Gigabit internet indicator cable to connect to the LAN status indicator. When this indicator flickers, it means that the internet is properly connected.

### C. Locator LED (6-pin LOCATOR)

This header is for the locator switch and LED on the front panel.

---

## Front and Rear Fan Connectors

(4-pin FRNT\_FAN1)  
(see p.13 or 15, No. 17)

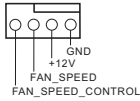

(4-pin FRNT\_FAN2)  
(see p.13 or 15, No. 16)

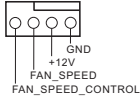

(4-pin REAR\_FAN1)  
(see p.13 or 15, No. 3)

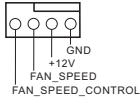

(4-pin REAR\_FAN2)  
(see p.13 or 15, No. 4)

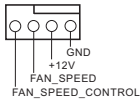

Please connect the fan cables to the fan connectors and match the black wire to the ground pin. All fans supports Fan Control.

---

## CPU Fan Connectors

(4-pin CPU\_FAN1)  
(see p.13 or 15, No. 5)

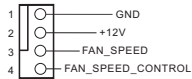

(4-pin CPU\_FAN2)  
(see p.13 or 15, No. 6)

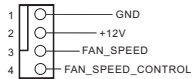

Please connect the CPU fan cable to the connector and match the black wire to the ground pin.



Though this motherboard provides a 4-Pin CPU fan (Quiet Fan) connector, 3-Pin CPU fans can still work successfully even without the fan speed control function. If you plan to connect a 3-Pin CPU fan to the CPU fan connector on this motherboard, please connect it to Pin 1-3.

**Pin 1-3 Connected** ←



3-Pin Fan Installation

### ATX Power Connector

(24-pin ATXPWR1)

(see p.13 or 15, No. 1)

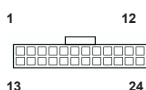

Please connect an ATX power supply to this connector.



Though this motherboard provides a 24-pin ATX power connector, it can still work if you adopt a traditional 20-pin ATX power supply. To use a 20-pin ATX power supply, please plug your power supply along Pin 1 and Pin 13.

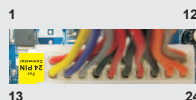

20-Pin ATX Power Supply Installation

### Intelligent Platform Management Bus header

(4-pin IPMB\_1)

(see p.13 or 15, No. 24)

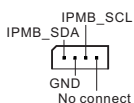

This 4-pin connector is used to provide a cabled baseboard or front panel connection for value added features and 3rd-party add-in cards, such as Emergency Management cards, that provide management features using the IPMB.

### Non Maskable Interrupt Button Header

(2-pin NMI\_BTN1)

(see p.13 or 15, No. 21)



Please connect a NMI device to this header.

---

### BMC SMB Headers

(5-pin BMC\_SMB\_1)  
(see p.13 or 15, No. 26)



This header is used for the  
SM BUS devices.

(5-pin BMC\_SMB\_2)  
(see p.13 or 15, No. 25)



(5-pin BMC\_SMB\_3)  
(see p.13 or 15, No. 20)



---

## **2.7 Driver Installation Guide**

To install the drivers to your system, please insert the support CD to your optical drive first. Then, the drivers compatible to your system can be auto-detected and listed on the support CD driver page. Please follow the order from top to bottom to install those required drivers. Therefore, the drivers you install can work properly.

---

## Chapter 3: UEFI SETUP UTILITY

### 3.1 Introduction

This section explains how to use the UEFI SETUP UTILITY to configure your system. The UEFI chip on the motherboard stores the UEFI SETUP UTILITY. You may run the UEFI SETUP UTILITY when you start up the computer. Please press <F2> or <Del> during the Power-On-Self-Test (POST) to enter the UEFI SETUP UTILITY, otherwise, POST will continue with its test routines.

If you wish to enter the UEFI SETUP UTILITY after POST, restart the system by pressing <Ctl> + <Alt> + <Delete>, or by pressing the reset button on the system chassis. You may also restart by turning the system off and then back on.



Because the UEFI software is constantly being updated, the following UEFI setup screens and descriptions are for reference purpose only, and they may not exactly match what you see on your screen.

#### 3.1.1 UEFI Menu Bar

The top of the screen has a menu bar with the following selections:

- Main** For setting system time/date information
- Advanced** For advanced system configurations
- H/W Monitor** Displays current hardware status
- IntelRCSetup** For Intel CPU and chipset settings
- Server Mgmt** For managing the server
- Event Logs** For event log configuration
- Security** For security settings
- Boot** For configuring boot settings and boot priority
- Exit** Exit the current screen or the UEFI Setup Utility

---

### 3.1.2 Navigation Keys

Use < ← > key or < → > key to choose among the selections on the menu bar, and use < ↑ > key or < ↓ > key to move the cursor up or down to select items, then press <Enter> to get into the sub screen. You can also use the mouse to click your required item.

Please check the following table for the descriptions of each navigation key.

| Navigation Key(s) | Function Description                               |
|-------------------|--|
| + / -             | To change option for the selected items            |
| <Tab>             | Switch to next function                            |
| <PGUP>            | Go to the previous page                            |
| <PGDN>            | Go to the next page                                |
| <HOME>            | Go to the top of the screen                        |
| <END>             | Go to the bottom of the screen                     |
| <F1>              | To display the General Help Screen                 |
| <F7>              | Discard changes and exit the SETUP UTILITY         |
| <F9>              | Load optimal default values for all the settings   |
| <F10>             | Save changes and exit the SETUP UTILITY            |
| <F12>             | Print screen                                       |
| <ESC>             | Jump to the Exit Screen or exit the current screen |



---

## 3.2 Main Screen

When you enter the UEFI SETUP UTILITY, the Main screen will appear and display the system overview.

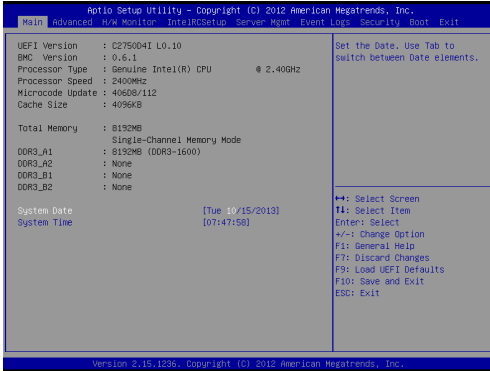

---

### 3.3 Advanced Screen

In this section, you may set the configurations for the following items: Storage Configuration, ACPI Configuration, Super IO Configuration, Serial Port Console Redirection, PCI Subsystem Settings, PLX 8608 Configuration and Voltage.

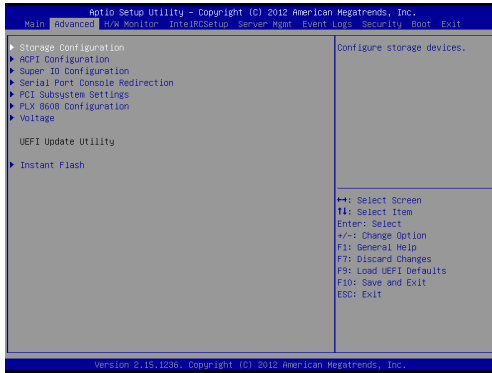

Setting wrong values in this section may cause the system to malfunction.

#### Instant Flash

Instant Flash is a UEFI flash utility embedded in Flash ROM. This convenient UEFI update tool allows you to update system UEFI without entering operating systems first like MS-DOS or Windows®. Just save the new UEFI file to your USB flash drive, floppy disk or hard drive and launch this tool, then you can update your UEFI only in a few clicks without preparing an additional floppy diskette or other complicated flash utility. Please be noted that the USB flash drive or hard drive must use FAT32/16/12 file system. If you execute Instant Flash utility, the utility will show the UEFI files and their respective information. Select the proper UEFI file to update your UEFI, and reboot your system after the UEFI update process is completed.

### 3.3.1 Storage Configuration

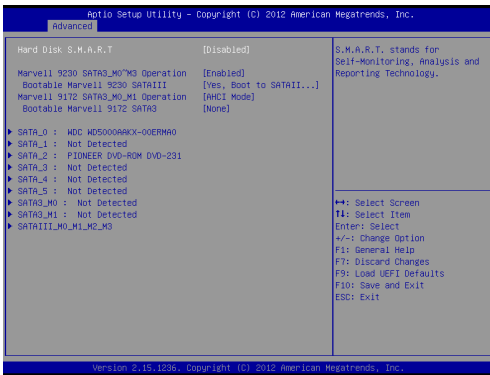

#### Hard Disk S.M.A.R.T.

Use this to enable or disable S.M.A.R.T. (Self-Monitoring, Analysis, and Reporting Technology).

#### Marvell 9230 SATA3\_M0~M3 Operation

This item is for Marvell 9230 SATA3\_M0~M3 ports. Use this to select Marvell SATA3 mode. Configuration options: [Enabled] and [Disabled]. The default value is [Enabled].

#### Bootable Marvell 9230 SATAIII

Use this to enable or disable Marvell SATA Boot ROM.

#### Marvell 9172 SATA3\_M0\_M1 Operation

This item is for Marvell 9172 SATA3\_M0 and M1 ports. Use this to select Marvell SATA3 mode. Configuration options: [Disabled], [IDE Mode], [AHCI Mode] and [RAID Mode]. The default value is [AHCI Mode].

#### Bootable Marvell 9172 SATA3

Use this to enable or disable Marvell SATA Boot ROM.



We recommend to use Intel® SATA ports (SATA\_0 to SATA\_5 ports) for your bootable devices. This will minimum your boot time and get the best performance. But if you still want to boot from Marvell SATA3 controller, you can still enable this in UEFI.

---

## 3.3.2 ACPI Configuration

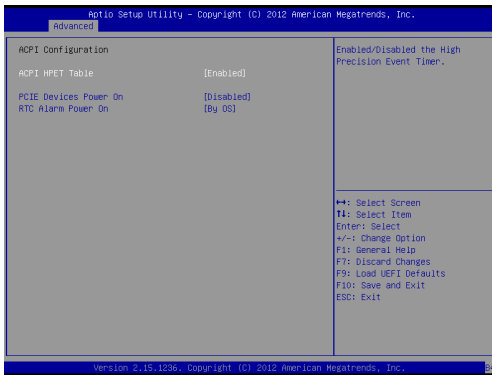

### ACPI HPET Table

Enable the High Precision Event Timer for better performance.

### PCIe Devices Power On

Use this item to enable or disable PCIe devices to turn on the system from the power-soft-off mode.

### RTC Alarm Power On

Use this item to enable or disable RTC (Real Time Clock) to power on the system.

---

### 3.3.3 Super IO Configuration

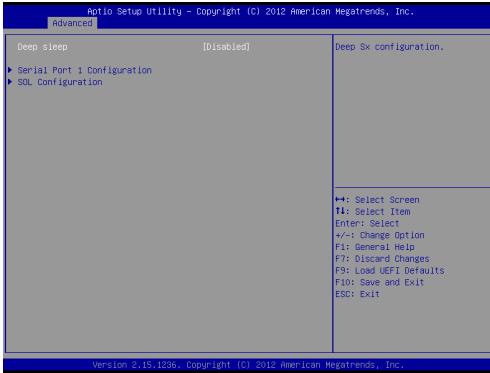

#### Deep Sleep

Use this to configure Deep Sleep. The default value is [Disabled].

#### Serial Port 1 Configuration

Use this item to configure the onboard serial port 1.

#### SOL Configuration

Use this item to configure the onboard serial port 2.

---

### 3.3.4 Serial Port Console Redirection

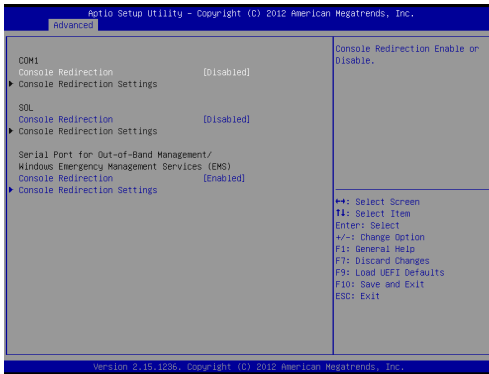

#### Console Redirection

Use this option to enable or disable Console Redirection.

#### Console Redirection Settings

Use this option to configure Console Redirection Settings.

---

### 3.3.5 PCI Subsystem Settings

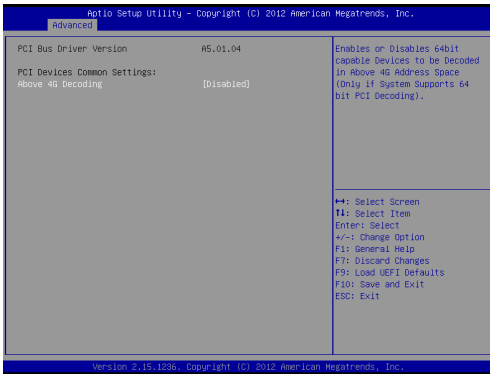

#### Above 4G Decoding

Use this option to enable or disable 64bit capable devices to be decoded in above 4G address space (only if system supports 64bit PCI decoding).

---

### 3.3.6 PLX 8608 Configuration

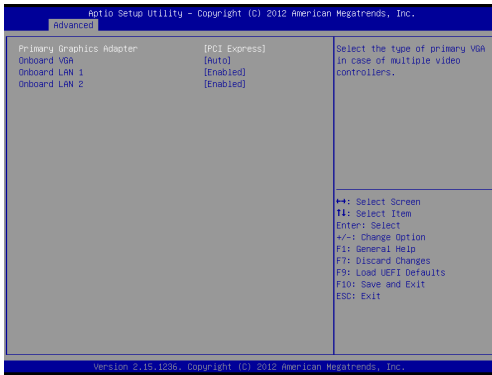

#### Primary Graphics Adapter

This allows you to select [Onboard] or [PCI Express] as the boot graphic adapter priority. The default value is [PCI Express].

#### Onboard VGA

This allows you to enable or disable the Onboard VGA feature.

#### Onboard LAN1

This allows you to enable or disable the Onboard LAN1 feature.

#### Onboard LAN2

This allows you to enable or disable the Onboard LAN2 feature.



---

### 3.3.7 Voltage



#### DRAM Voltage

Use this to select DRAM Voltage. The default value is [Auto].

---

### 3.4 Hardware Health Event Monitoring Screen

In this section, it allows you to monitor the status of the hardware on your system, including the parameters of the CPU temperature, motherboard temperature and the critical voltage.

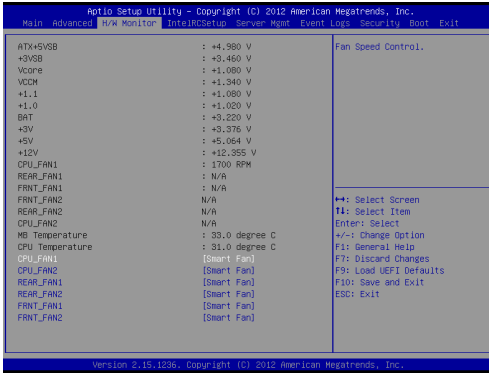

#### CPU\_FAN1 Setting

This allows you to set the speed of CPU fan 1. The default value is [Smart Fan].

#### CPU\_FAN2 Setting

This allows you to set the speed of CPU fan 2. The default value is [Smart Fan].

#### REAR\_FAN1 Setting

This allows you to set the speed of REAR Fan 1. The default value is [Smart Fan].

#### REAR\_FAN2 Setting

This allows you to set the speed of REAR Fan 2. The default value is [Smart Fan].

#### FRNT\_FAN1 Setting

This allows you to set the speed of FRNT Fan 1. The default value is [Smart Fan].

#### FRNT\_FAN2 Setting

This allows you to set the speed of FRNT Fan 2. The default value is [Smart Fan].

---

### 3.5 IntelRCSetup

In this section, you may set the configurations for the following items: Processor Configuration, Clock Generation Configuration, North Bridge Chipset Configuration, South Bridge Chipset Configuration and System Event Log.

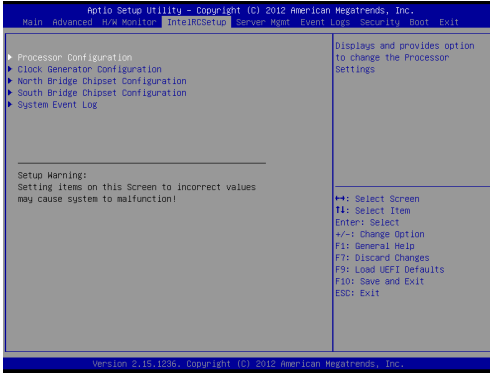

Setting wrong values in this section may cause the system to malfunction.

---

## 3.5.1 Processor Configuration

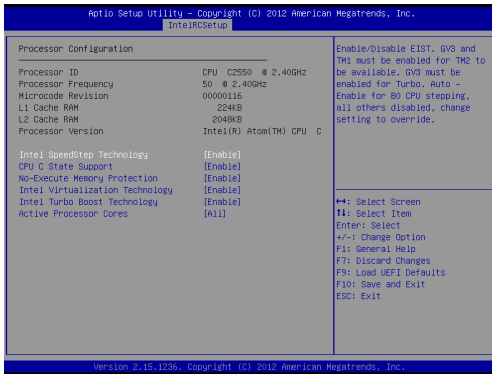

### Intel SpeedStep Technology

Intel SpeedStep technology is Intel's new power saving technology. Processors can switch between multiple frequencies and voltage points to enable power saving. The default value is [Enabled]. Configuration options: [Enabled] and [Disabled]. This item will be hidden if the current CPU does not support Intel SpeedStep technology.



Please note that enabling this function may reduce CPU voltage and lead to system stability or compatibility issues with some power supplies. Please set this item to [Disabled] if above issues occur.

### CPU C State

Use this to enable or disable the support of CPU C State.

### No-Execute Memory Protection

Processors with No-Execution Memory Protection Technology may prevent certain classes of malicious buffer overflow attacks.

### Intel Virtualization Technology

When this option is set to [Enabled], a VMM (Virtual Machine Architecture) can utilize the additional hardware capabilities provided by Vanderpool Technology. This option will be hidden if the installed CPU does not support Intel Virtualization Technology.

---

### **Intel Turbo Boost Technology**

Use this item to enable or disable Intel Turbo Boost Mode Technology. Turbo Boost Mode allows processor cores to run faster than marked frequency in specific conditions. The default value is [Enabled].

### **Active Processor Cores**

Use this item to select the number of cores to enable in each processor package. The default value is [All].

---

## 3.5.2 Clock Generation Configuration

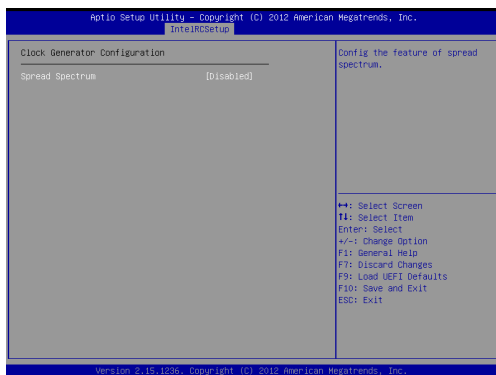

### Spread Spectrum

Enable Spread Spectrum to reduce electromagnetic interference for passing EMI tests. Disable to achieve higher clock speeds when overclocking.

---

### 3.5.3 North Bridge Chipset Configuration

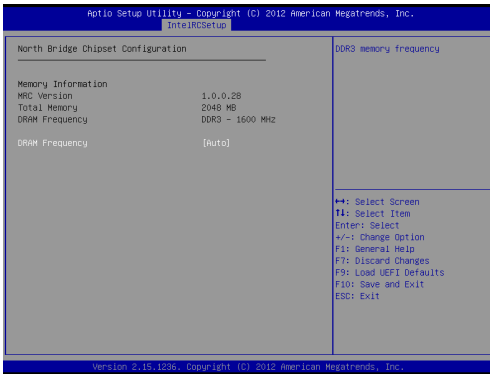

#### DRAM Frequency

If [Auto] is selected, the motherboard will detect the memory module(s) inserted and assign the appropriate frequency automatically.

---

## 3.5.4 South Bridge Chipset Configuration

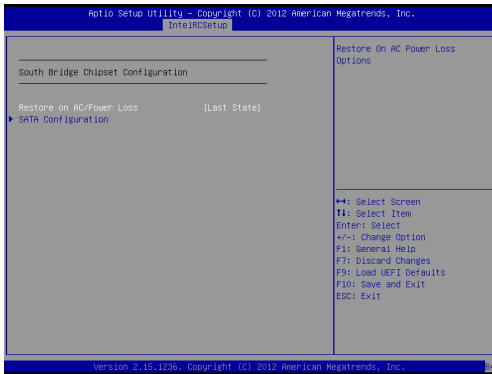

### Restore on AC/Power Loss

Select the power state after a power failure. If [Power Off] is selected, the power will remain off when the power recovers. If [Power On] is selected, the system will start to boot up when the power recovers.

### SATA Configuration

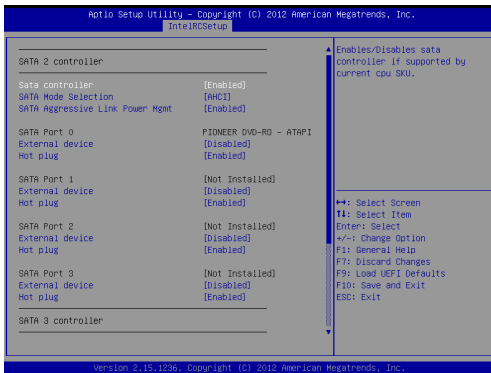

### SATA Controller

Use this item to enable or disable the SATA Controller feature.

### SATA Mode Selection

Use this to select SATA mode.



---

## **SATA Aggressive Link Power Management**

Use this item to configure Aggressive Link Power Management.

---

## 3.5.5 System Event Log

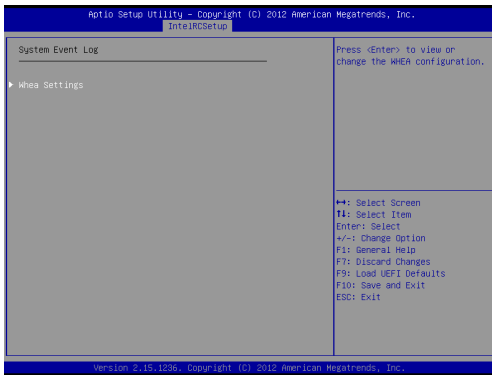

### Whea Settings

Use this option to configure Windows Hardware Error Architecture.

---

## 3.6 Server Management

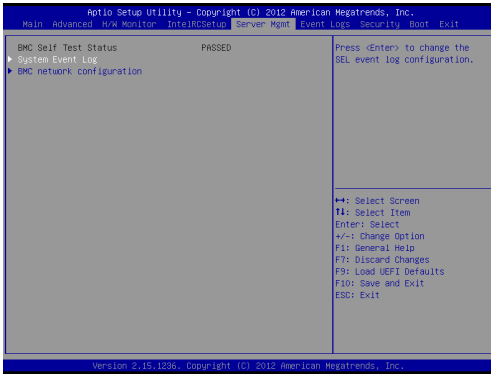

### System Event Log

Enter to configure System Event Logging features during boot.

### BMC Network Configuration

Enter to configure BMC Network parameters.

---

## 3.7 Event Logs

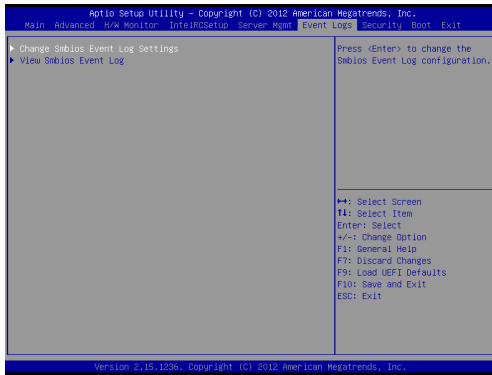

### Change Smbios Event Log Settings

This allows you to configure the Smbios Event Log Settings.

### View Smbios Event Log

This allows you to view the Smbios Event Log.

---

## 3.8 Security Screen

In this section, you may set or change the supervisor/user password for the system. For the user password, you may also clear it.

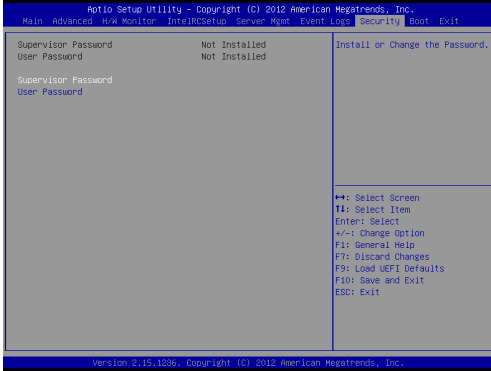

---

### 3.9 Boot Screen

In this section, it will display the available devices on your system for you to configure the boot settings and the boot priority.



#### Setup Prompt Timeout

This shows the number of seconds to wait for setup activation key.

#### Bootup Num-Lock

If this item is set to [On], it will automatically activate the Numeric Lock function after boot-up.

#### PCI ROM Priority

In case of multiple option ROMs (Legacy and EFI Compatible), specifies what PCI optionROM to launch. Configuration options: [Legacy ROM] and [EFI Compatible ROM].

#### Full Screen Logo

Use this item to enable or disable OEM Logo. The default value is [Enabled].

#### AddOn ROM Display

Use this option to adjust AddOn ROM Display. If you enable the option "Full Screen Logo" but you want to see the AddOn ROM information when the system boots, please select [Enabled]. Configuration options: [Enabled] and [Disabled]. The default value is [Enabled].

#### Boot From Onboard LAN

Allow the system to be waked up by the onboard LAN.

---

---

## 3.10 Exit Screen

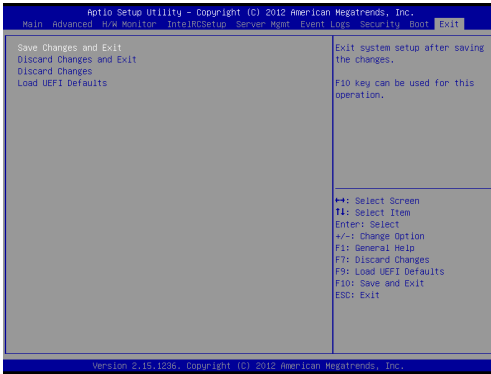

### Save Changes and Exit

When you select this option, the following message “Save configuration changes and exit setup?” will pop-out. Select [Yes] to save the changes and exit the UEFI SETUP UTILITY.

### Discard Changes and Exit

When you select this option, the following message “Discard changes and exit setup?” will pop-out. Select [Yes] to exit the UEFI SETUP UTILITY without saving any changes.

### Discard Changes

When you select this option, the following message “Discard changes?” will pop-out. Select [Yes] to discard all changes.

### Load UEFI Defaults

Load UEFI default values for all the setup questions. F9 key can be used for this operation.

---

## **Chapter 4: Software Support**

### **4.1 Install Operating System**

This motherboard supports Microsoft® Windows® Server 2008 R2 / Linux compliant. Because motherboard settings and hardware options vary, use the setup procedures in this chapter for general reference only. Refer your OS documentation for more information.

### **4.2 Support CD Information**

The Support CD that came with the motherboard contains necessary drivers and useful utilities that enhance the motherboard's features.

#### **4.2.1 Running The Support CD**

To begin using the support CD, insert the CD into your CD-ROM drive. The CD automatically displays the Main Menu if "AUTORUN" is enabled in your computer. If the Main Menu does not appear automatically, locate and double click on the file "ASRSETUP.EXE" in the Support CD to display the menu.

#### **4.2.2 Drivers Menu**

The Drivers Menu shows the available device's drivers if the system detects installed devices. Please install the necessary drivers to activate the devices.

#### **4.2.3 Utilities Menu**

The Utilities Menu shows the application softwares that the motherboard supports. Click on a specific item then follow the installation wizard to install it.

#### **4.2.4 Contact Information**

If you need to contact ASRock Rack or want to know more about ASRock Rack, you're welcome to visit ASRock Rack's website at <http://www.asrock.com>; or you may contact your dealer for further information.



---

# Chapter 5: Troubleshooting

## 5.1 Troubleshooting Procedures

Follow the procedures below to troubleshoot your system.



Always unplug the power cord before adding, removing or changing any hardware components. Failure to do so may cause physical injuries to you and damages to motherboard components.

1. Disconnect the power cable and check whether the PWR LED is off.
2. Unplug all cables, connectors and remove all add-on cards from the motherboard. Make sure that the jumpers are set to default settings.
3. Confirm that there are no short circuits between the motherboard and the chassis.
4. Install a CPU and fan on the motherboard, then connect the chassis and power LED.

### **If there is no power...**

1. Confirm that there are no short circuits between the motherboard and the chassis.
2. Make sure that the jumpers are set to default settings.
3. Check the settings of the 115V/230V switch on the power supply.
4. Verify if the battery on the motherboard provides ~3VDC. Install a new battery if it does not.

### **If there is no video...**

1. Try replugging the monitor cables and power cord.
2. Check for memory errors.

### **If there are memory errors...**

1. Verify that the DIMM modules are properly seated in the slots.
2. Use recommended DDR3 1600/1333/1066 ECC DIMMs.
3. If you have installed more than one DIMM modules, they should be identical with the same brand, speed, size and chip-type.
4. Try inserting different DIMM modules into different slots to identify

---

faulty ones.

5. Check the settings of the 115V/230V switch on the power supply.

### **Unable to save system setup configurations...**

1. Verify if the battery on the motherboard provides ~3VDC. Install a new battery if it does not.
2. Confirm whether your power supply provides adequate and stable power.

### **Other problems...**

1. Try searching keywords related to your problem on ASRock Rack's FAQ page:  
<http://www.asrock.com/support/faq.asp>
2. Try downloading and updating the latest UEFI on ASRock Rack's website:  
<http://www.asrock.com/support/download.asp>

---

## 5.2 Technical Support Procedures

If you have tried the troubleshooting procedures mentioned above and the problems are still unsolved, please contact ASRock Rack's technical support with the following information:

1. Your contact information
2. Model name, BIOS version and problem type.
3. System configuration.
4. Problem description.

You may contact ASRock Rack's technical support at:

<http://www.asrock.com/support/tsd.asp>

## 5.3 Returning Merchandise for Service

For warranty service, the receipt or a copy of your invoice marked with the date of purchase is required. By calling your vendor or going to our RMA website (<http://www.asrock.com/support/index.asp?cat=RMA>) you may obtain a Returned Merchandise Authorization (RMA) number.

The RMA number should be displayed on the outside of the shipping carton which is mailed prepaid or hand-carried when you return the motherboard to the manufacturer. Shipping and handling charges will be applied for all orders that must be mailed when service is complete.

This warranty does not cover damages incurred in shipping or from failure due to alteration, misuse, abuse or improper maintenance of products.

Contact your distributor first for any product related problems during the warranty period.

---

## Chapter 6: Net Framework Installation Guide

To let Intel® RSTe works properly, it is required to install Net Framework. Please follow the steps below to enable “.Net Framework” feature on Microsoft® Windows® Server 2008 R2.

### Installing .Net Framework 3.5.1 (For Server 2008 R2)

1. Double-click the **Server Manager** icon in the Windows system tray.

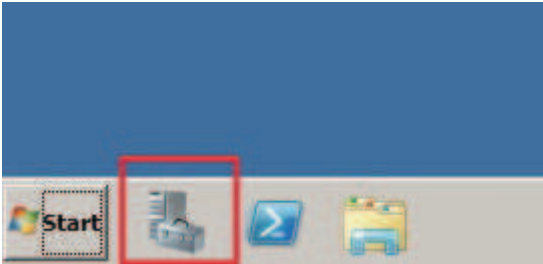

2. Click **Add Features** in the right hand pane.

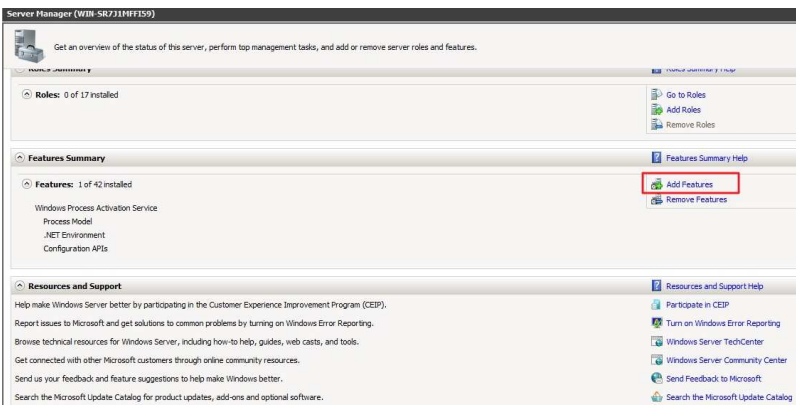

### 3. Check the box next to **.Net Framework 3.5.1** and then click **Next**.

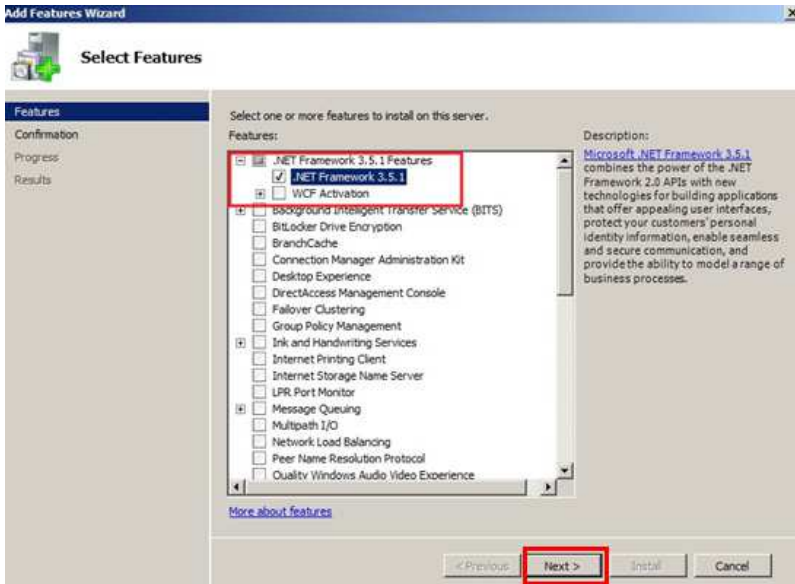

Click **Next** to continue.

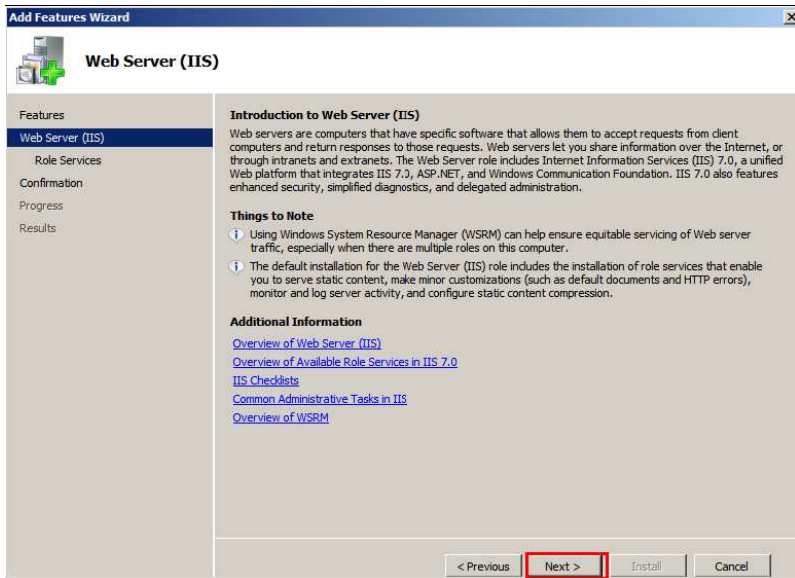

4. Click **Install** to start installing .Net Framework 3.5.1.

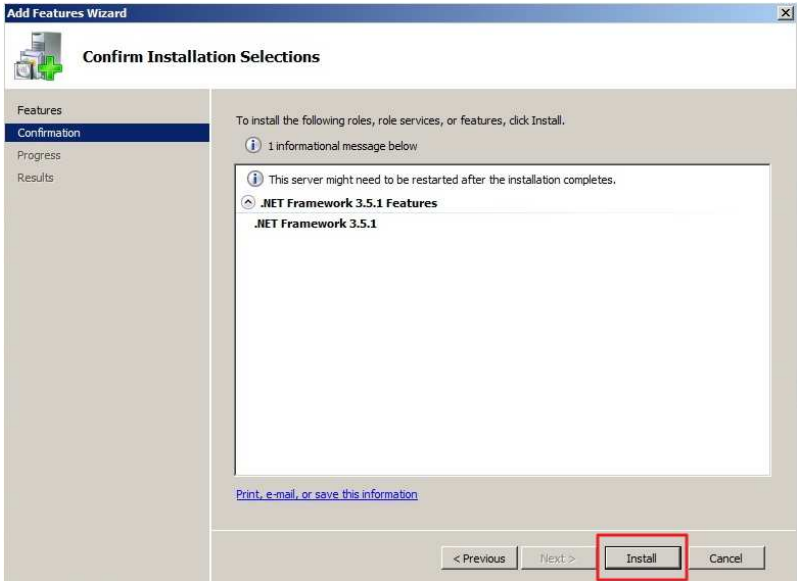

5. After the installation completes, click **Close**.

