

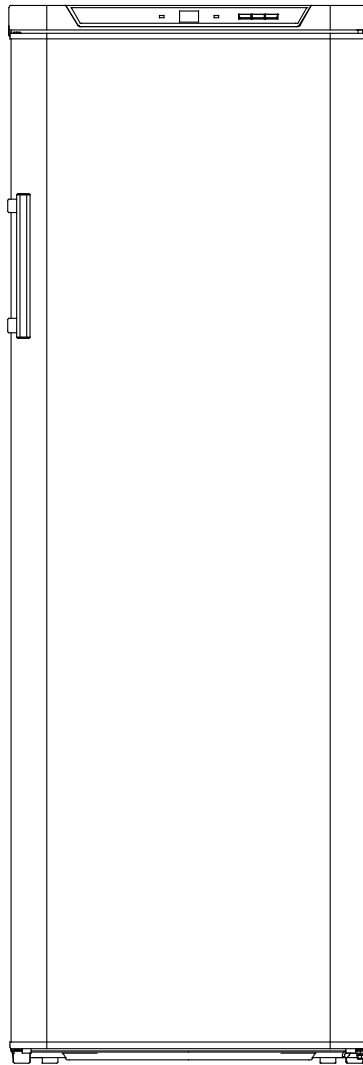

**UPRIGHT REFRIGERATOR USER MANUAL**



**FR-450**



# Operating Instructions

**Dear customer,**

To enable you to use your new **REFRIGERATOR** effectively and safely, please read this instruction book carefully before you use the appliance, which contains important information for installation, safe use and maintenance of this appliance. Please keep the book for future reference and remember to pass it on to the new owner. The following symbols will be found in the book to guide you through the instructions:

Guide to use the instruction book			
	Warnings		Operating instructions
	Tips and notes		

**Warnings** are stressed with a warning triangle or with signal words (Warning!, Important!), which are provided in the interest of your safety. Ensure that you understand them all before installing and using this appliance.

**Tips and notes** will inform you with necessary knowledge of how to use the appliance economically and environmentally.

**Operating instructions** presented in the section of “Trouble shooting” contain instructions for correction of possible malfunctions by users.

# INDEX

	Page No.
<b>Important Safety Instructions</b> .....	4
<b>Installation Instructions</b> .....	5
<b>Description of the Appliance</b> .....	6
<b>Using Your Appliance</b> .....	7
<b>Thermostat Control</b> .....	8
<b>Change the Reversible Door</b> .....	9
<b>Hints and Tips</b> .....	11
<b>Trouble Shooting</b> .....	12
<b>Correct Positioning</b> .....	13

## Important Safety Instructions

These warnings are provided in the interest of your safety. Ensure that you understand them all before installing or using this appliance. Your safety is of paramount importance. If you are still unsure about the meaning of these warnings, contact the supplier for assistance.

### Intended use

The refrigerator is designed for domestic use only, in detail for storage of edible foods at low temperature. If the refrigerator is used for other purposes such as commercial applications or used incorrectly, the manufacturer accepts no liability for any damage that may occur. Alterations or changes to the refrigerator are not permitted for reasons of safety.

### Prior to initial start-up

Check the appliance for transport damage. Under no circumstances should a damaged appliance be plugged in. In the event of serious damage, contact your supplier.

### Refrigerant

Refrigerant gas is contained within the refrigerant circuit of the appliance. Ensure that none of the components of the refrigerant circuit becomes damaged during transportation and installation.

If the refrigerant circuit should be damaged:

- Avoid opening near flames and sources of ignition.
- Thoroughly ventilate the room in which the appliance is situated.



Other warnings include:

- **WARNING** — Keep ventilation openings, in the appliance enclosure or in the built-in structure, clear of obstruction.
- **WARNING** — Do not use mechanical devices or other means to accelerate the defrosting process, other than those recommended by the manufacturer.
- **WARNING** — Do not damage the refrigerant circuit.
- **WARNING** — Do not use electrical appliances inside the food storage compartments of the recommended by the manufacturer.
- **WARNING** — The appliance is not intended for use by young children without supervision.
- **WARNING** — Young children should be supervised to ensure that they do not play with the appliance.
- **WARNING** — When disposing of the appliance do so only at an authorized waste disposal centre. Do not expose to flame.
- **WARNING** — If the supply cord is damaged, it must be replaced by the manufacturer or their service agent or a similarly qualified person in order to avoid a hazard.

## **Safety of children**

Packaging (e.g. wraps, polystyrene) can be dangerous for children. There is a risk of suffocation! Keep packaging materials away from children!

Remember to dispose the old appliance that is unusable. Pull out the mains plug, cut off the mains cable, break or remove spring or bolt catches if fixed. And ensure that children cannot lock themselves in the appliance when playing (there is risk of suffocation) or involve themselves in other dangers, for children cannot recognize the hazard present in household appliances themselves. Therefore, it is very important for parents to have adequate supervision in case children play with the appliance!

## **Daily operation**

Containers with flammable gases or liquids can leak at low temperatures. There is a risk of explosion! Do not store any container with flammable materials such as spray cans in the refrigerator.

Do not operate any electrical appliance in the refrigerator (e.g. electric ice cream makers, mixers etc.).

Before cleaning the appliance, always switch off the appliance and unplug it, or put the house fuse or switch off on the circuit breaker.

## **In case of malfunction**

If a malfunction occurs, please look first in the “Trouble Shooting” section for help. If the information given there does not help, ask your supplier for help. Under no circumstances should you attempt to repair the appliance yourself, as repairs carried out by inexperienced persons may cause injuries or serious malfunctions.

# **Installation Instructions**

## **Installation Requirements**

The appliance should be placed in a dry and well-ventilated room. As the performance and energy consumption of the refrigerator can be affected by the ambient temperature, the following instructions should be ensured:

- Do not expose the appliance to direct sunlight,
- Do not install the appliance close to radiators, cookers or other sources of heat,
- Place the appliance in a location where the ambient temperature corresponds to the climate classification for which it is designed. You can find the climate classification on the circuit-diagram-serial-plate located at the left-upper side of the appliance. The following table shows this climate classification and its matching ambient temperature:

Climate classification	Ambient temperature
SN	10~32°C
N	16~32°C
ST	18~38°C
T	18~43°C

Your appliance will be heavy when loaded with foods and must therefore be placed on a strong firm floor and ensure the power socket is accessible.

## Ventilation Requirements

Ensure that the air can circulate freely around the cabinet. There should be 100mm between the top of the appliance and any overhanging furniture, and a gap of 25mm on either side of the appliance.

Ensure that the appliance does not stand on the electrical supply cable. Parts that heat up should not be exposed. Whenever possible the back of the appliance should be close to a wall but remember to leave the suitable distance required for ventilation.

## Leveling

The appliance should be level in order to eliminate rocking. To make the appliance level, it should be upright and both adjusters should be firmly contacted with the floor. You can also adjust the level by screwing out the appropriate level adjuster at the front (use your fingers or a suitable spanner), but much care should be taken when moving this appliance as it may be heavy.

## Description of the Appliance

### View of the appliance

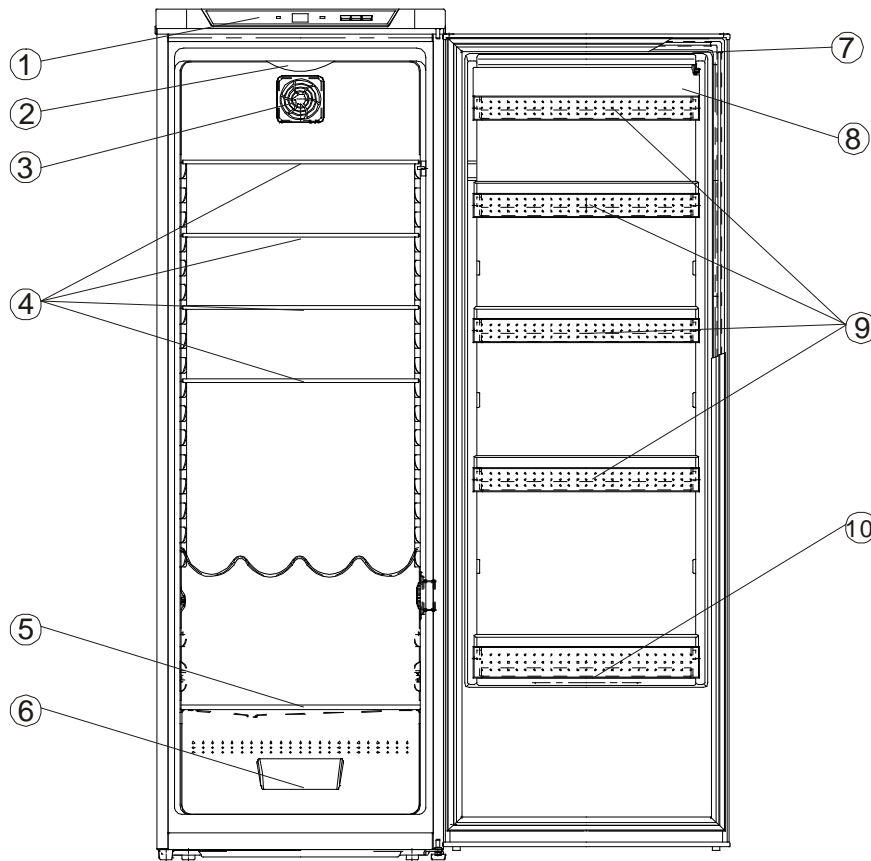

1. Control panel   2. Lamp (inside)   3. Air outlet   4. Shelf   5. Crisper cover  
6. Crisper drawer   7. Door rack cover   8. Egg rack(inside)   9. Door rack   10. Door lower rack

### Note:

Due to the updated modifications of our products, your refrigerator may differ slightly from this Instruction Manual, but the functions and using methods remain the same.

## Refrigerator Chamber

The refrigerator compartment is for storing food that does not need to be frozen. Temperatures in the refrigerator compartment differ in each section, to accommodate different types of food, as shown in the diagram below:

- ① Suitable for storing cake, cooked-foods, sweetmeats, canned foods, meat, dairy products, etc.
- ② Suitable for storing fruits, vegetables, salads, etc.
- ③ Suitable for storing eggs.
- ④ Suitable for storing small bottles, etc.
- ⑤ Suitable for storing butter, cheese, etc.

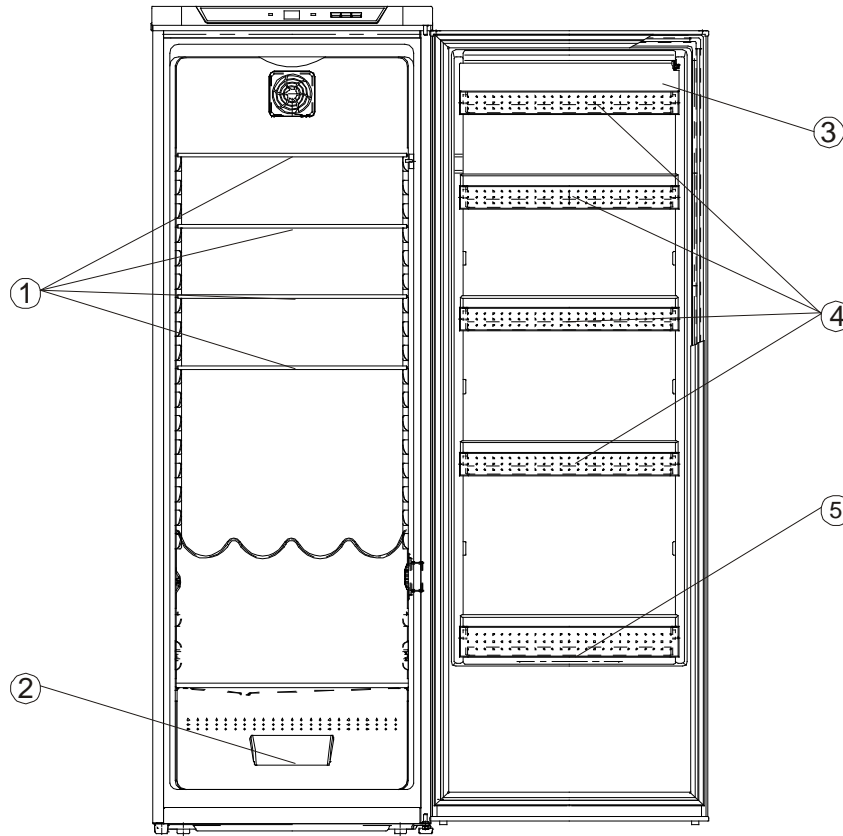

### Shelf of refrigerator chamber

There are five adjustable shelves in the refrigerator chamber, which can be removed for cleaning.

### Crisper cover

This is for controlling the temperature in the crisper drawer to prevent vegetables losing moisture. The controlling knob on the cover can be used to regulate the humidity in the drawer. By closing the controls, that will decrease the humidity.

## Using Your Appliance

This appliance is designed for domestic use only, specifically for the storage of edible foods. And it is designed to operate in ambient temperatures (surrounding air temperature) between 16 °C and 38 °C. If the ambient temperature is either colder or warmer, the appliance will not work effectively and correctly. Should the ambient temperature be exceeded for a long period of time, the temperature in the **REFRIGERATOR** will rise above -18 °C and food spoilage may occur.

## Before use

Remove all securing tapes. Wash the inside of the appliance with lukewarm water added with a little bicarbonate of soda (5ml to 0.5 liter of water). Do not use soap or detergent as the smell may linger. After cleaning, dry the appliance thoroughly.

## To start the appliance

### Operating instructions

1. Allow the appliance to stand for 2 hours after installation.
2. Plug in the appliance and turn on the power.
3. Turn the thermostat control to the required setting. A midway setting is usually suitable for normal operation.
4. Leave the appliance switched on for approximately 4 hours to reach the correct temperature before placing food inside.

## Thermostat Control

The thermostat control panel controls the temperature inside the refrigerator compartment or **REFRIGERATOR** compartment, and is located on the top cover plate.

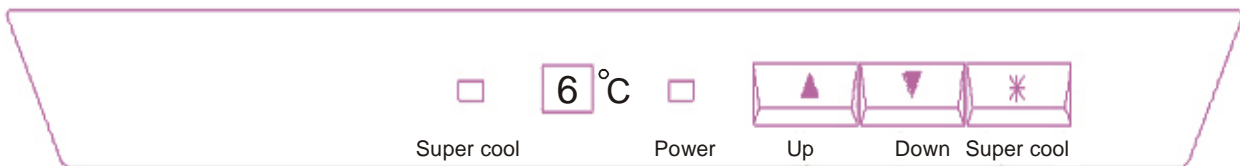

### ● INDICATOR LIGHT OF POWER

When the refrigerator gets connection to power, it starts to work and the indicator light of power is on. When the refrigerator loses connection to power, the indicator light is off.

### ● THERMOSTAT OF THE REFRIGERATOR

If you press the ▲ or ▼ button, you can select the temperature ranging from +1°C to +10°C. If you press and hold the ▲ or ▼ button for longer than 1 second, the temperature will increase or decrease rapidly. When you adjust temperature, the temperature display will flash. If you don't touch any button for about 5 seconds, the selected temperature will be set up and flash stops. Then the temperature display shows the current actual temperature inside the refrigerator.

### ● SUPER COOL

By simply pressing the super cool button, the refrigerator will operate in the super cool mode. The indicator light of super cool will be on. In super cool mode, the temperature inside the refrigerator will drop rapidly until the temperature reaches your setting. Then the refrigerator will automatically quit the super cool mode. The indicator light of super cool will be off. Before that you can also manually quit the super cool mode by pressing the super cool button again.

### ● ALARM

If the door is left open for 2 minutes, the alarm will sound to remind you closing the door. If the door is still open, the alarm will sound 3 times per 30 seconds and last for 10 minutes. Then the alarm will automatically stop.



## Change the Reversible Door

The refrigerator is supplied with the door hinges on the right side. If you wish to change the opening direction, follow the instructions below:

### Warning!

When changing the side at which the door opens, the appliance must not be connected to the mains. Remove plug from the mains beforehand.

### Tip:

Food in the fridge should always be covered or packaged, to prevent drying and tainting of other food.

### The following are suited for packaging:

- Polyethylene airtight bags and wraps
- Plastic containers with lids
- Special plastic covers with elastic
- Aluminium foil

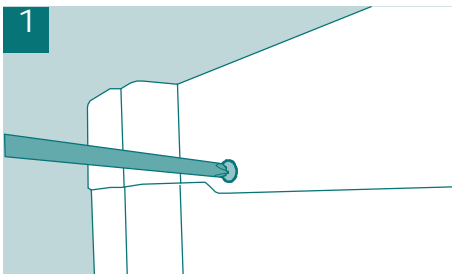
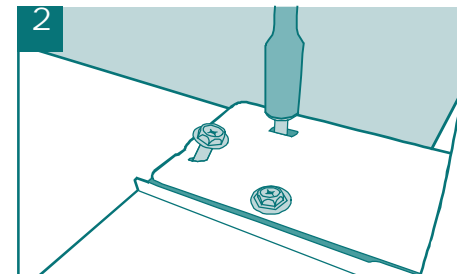
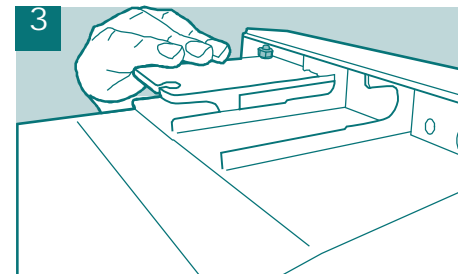
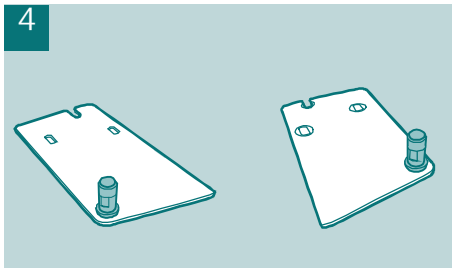
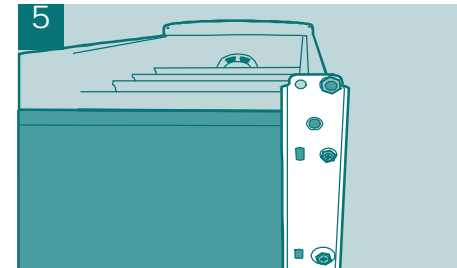
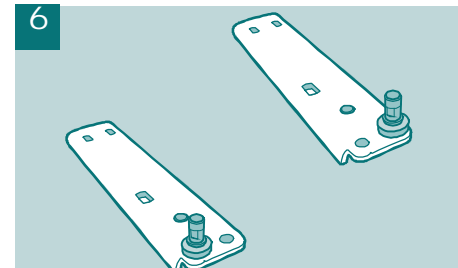
		
<p>Remove the three screws at the rear and the two screws at the top of the Larder Fridge and remove the lid.</p>	<p>Use an 8mm spanner to remove the bolts from the top bracket.</p>	<p>Lift the hinge bracket out of the recess in the door.</p>
		
<p>Remove the pin from the bracket with a 10mm spanner/socket. Replace in the same hole through the other side. Remove the door.</p>	<p>Lay the Larder Fridge backward. Remove the bottom hinge bracket using an 8mm socket or spanner.</p>	<p>Remove the pin and replace on the opposite side using a 10mm socket or spanner. Reattach bottom bracket to the Larder Fridge. Replace leveling feet. Stand upright and replace door.</p>

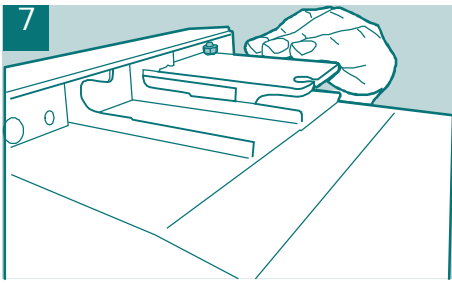

7  
Insert top hinge bracket into the recess on top of the door. Bolt into place using the three bolts removed earlier.

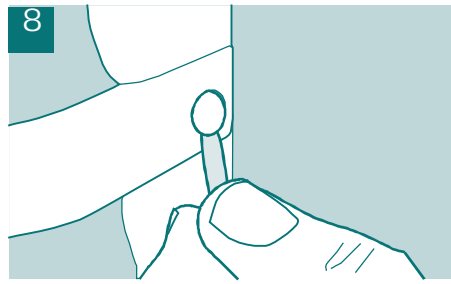

8  
Remove blanking plates from the door handle to reveal screws. Remove the two screws that secure the handle.

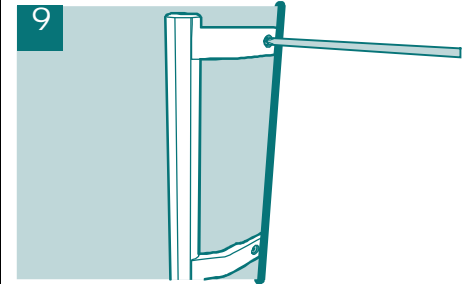

9  
Cover the holes left by the removed screws with the blanking plates. Re-secure the door handle on the other side. Cover screws with the blanking plates.

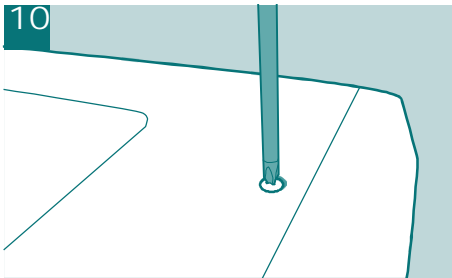

10  
Replace and secure the lid of the Larder Fridge with the two top screws and the three rear screws from step 1.

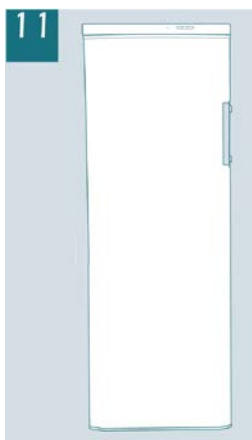

11  
Check the door is aligned horizontally and vertically. Re-adjust the adjustable feet.

## Hints and Tips

### Food storage

Avoid buying frozen food if you cannot store it.

Storage in original food containers is advisable. Place already frozen foods into the refrigerator as soon as possible, and be sure to:

- Not store too many items in the drawers.
- Allow air to circulate around each item.
- Not to store uncovered food.

Ensure the foods placed in the refrigerator are dated and labeled, and used them in date order, so you can consume them at its best.

### Energy saving advice

Do not place the appliance close to heat sources such as cookers, dishwashers or radiators. Make sure the appliance is placed in a cool well-ventilated room so that the air can circulate very well.

Avoid unnecessary frosting in the cabinet by packing all foodstuffs into sealed packages. Avoid keeping the door open for a long time, as warm air will enter the cabinet and the cold air inside will leak out of the cabinet, which will cause energy wasting. Ensure that there is no obstruction preventing the door from closing properly.

### In the event of a power failure

If there is a power failure while the appliance is in operation, do not open the door. If the temperature inside your **REFRIGERATOR** should rise, causing food to defrost, do not refreeze the food.

#### The following guidelines will assist you:

- Ice cream: Once thawed should be discarded.
- Fruit and vegetables: If soft should be cooked as soon as possible.
- Bread and cakes: Can be refrozen without danger.
- Shellfish: Should be refrigerated and used up quickly.
- Cooked dishes: i.e. casseroles, should be refrigerated and used up.
- Large pieces of meat: Can be refrozen if there are ice crystals remaining within them.
- Small joints: Should be cooked and then refrozen as cooked dishes.
- Chicken: Should be cooked and refrozen as a fresh dish.

## Trouble Shooting

### Noises during Operation

The following noises are normal characteristics of the appliance when it works:

- Whenever the compressor switches on or off, a click can be heard.
- As soon as the compressor is in operation, you can hear it humming.
- When refrigerant flows into thin tubes, you can hear bubbling or splashing noises.
- Even after the compressor has been switched off, the noise of splashing can be heard for a short time.

Repairs to the **REFRIGERATOR** may only be conducted by qualified service engineers. Improper repairs can lead to significant hazards for users. If your appliance needs repairing, please contact your specialist dealer.

PROBLEM	SOLUTION
The refrigerator does not operate	Check that it is properly plugged in, that the fuse has not blown or that the circuit-breaker has not tripped.
The REFRIGERATOR is too warm	Check the thermostat and make sure that the door stays open as little as possible. Also check that the door closes properly.
The motor runs continuously	Make sure that the REFRIGERATOR is well ventilated, leaving gaps as mentioned in the “Installation” chapter. Also check that your appliance is not exposed to a direct source of heat. You may also have placed too much food inside or the door may not close properly.

## Correct Positioning

### Good ventilation

For the purpose of safety, reliance, low power consumption and durability to your fridge, a space should be left around the refrigerator. please keep 100mm of space between the back of the appliance and the wall.

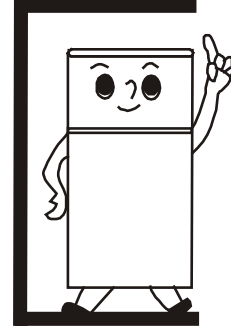

### Power supply

The refrigerator is only suitable to a single-phase alternating current of 220-240V, (50±1) Hz.

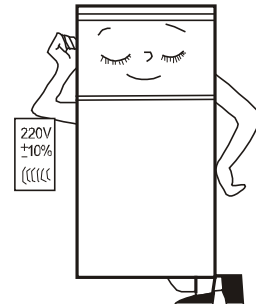

### Power Cord

The cord should be neither lengthened nor folded into a coil during operation. Moreover, it is imperative not to keep the power cord close to, or touching the compressor at the back of the fridge, as the surface temperature is quite warm while operating, and touching may melt the insulation and cause electrical leakage.

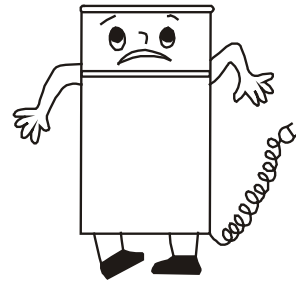

### Protection from Moisture

Avoid placing the fridge in a place where heavy moisture is present, to minimize the possibility of rusting any metal parts. It is imperative that the fridge not be directly sprayed with water, as it will cause poor insulation and current leakage may occur.



### **Level Surface**

The surface on which fridge is to be placed, must be flat and solid. It should not be laid on any soft material such as foam plastic, etc. if the fridge is not on level, adjust the casters.

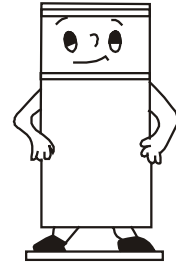

### **Protection from Heat**

The fridge should be far away from any heat source or direct sunshine.



### **Keep Away from Danger**

It is not advisable for the fridge to be placed near any combustibles such as gas, petrol, alcohol, lacquer, banana oil, etc.

The above-mentioned objects can not be stored in the refrigerator.

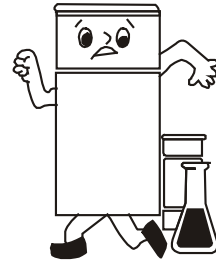

### **Moving**

When moving the fridge, do not lie it horizontally or lower it at an angle less than 45°.

