

# Air Heater Unit



Feel the drive

*Air Top 2000 ST B Additional Heater*

*Air Top 2000 ST D Additional Heater*



\*2001/56\*0022

## Installation Instructions

### VW T5

Gasoline and Diesel

from Model Year 2004

For left-hand drive vehicles only



#### **WARNING!**

**Hazard warning:**

**Incorrect installation or repair of Webasto heating systems may cause a fire or result in the emission of carbon monoxide, which can be fatal. Serious or fatal injuries can be caused as a result.**

**Specialist company training, technical documentation, specialized tools and equipment are required to install and repair Webasto heating and cooling systems.**

**NEVER attempt to install or repair Webasto heating or cooling systems if you have not successfully completed the company training and thereby acquired the required technical skills, or if you do not have access to the required technical documentation, tools and equipment needed to carry out correct installation and repairs.**

**ALWAYS follow all Webasto installation and repair instructions and observe all warnings.**

**Webasto does not accept any liability for defects and damage that are attributable to installation by untrained staff.**

**Table of Contents**

|  |    |   |    |
|--|----|---|----|
| Validity   | 2  | Fuel Removal on Vehicles                |    |
| Heater Units   | 3  | with Additional or Auxiliary Heater     | 14 |
| Foreword   | 3  | Exhaust System                          | 15 |
| General Instructions   | 3  | Optional Exhaust Muffler                | 15 |
| Special tools  | 3  | Optional Hot Air System                 | 16 |
| Explanatory Notes on the Document                                  | 4  | Optional Recirculating Air              | 19 |
| General Installation Diagram                                       | 5  | Electrical Connections                  | 20 |
| Preliminary Work   | 6  | Optional Combination Timer              | 20 |
| Heater Unit Installation Location                                  | 6  | External Temperature Sensor             | 20 |
| Preparing Installation Location                                    | 7  | Remote Option (Telestart)               | 21 |
| Preparing Heater Unit  | 8  | Fault Code Deactivation                 | 26 |
| Installing Heater Unit   | 9  | Final Work                              | 27 |
| Combustion Air   | 10 | Operating Instructions for End Customer | 28 |
| Fuel Connection  | 11 | Template for Fuel Sender                | 29 |
| Metering Pump  | 12 | Template for Fuel Standpipe             | 30 |
| Fuel Removal on Vehicles<br>without Additional or Auxiliary Heater | 13 |   |    |

**Validity**

| Manufacturer | Model       | Type | EG-BE No./ABE |
|--------------|-------------|------|---------------|
| Volkswagen   | Transporter | T5   | L148          |

**Foreword**

These installation instructions apply to VW T5 vehicles with a Gasoline and Diesel engine (van with partition wall) from model year 2004 and later, assuming technical modifications to the vehicle do not affect installation, any liability claims excluded.

Vehicles and equipment variants, which are not listed in these installation instructions, have not been tested. However, installation according to these installation instructions may be possible. Depending on the version and the equipment variants of the vehicle, changes may be necessary relative to these "installation instructions" during installation and must be adjusted accordingly.

However, where this is the case the stipulations in the "installation instructions" and "operating and maintenance instructions" for the *Air Top 2000 ST* should be observed.

The installation location of heater controls and the routing of the air ducting parts must be coordinated with the final customer prior to installation!

**WARNING!**

Original load-bearing components of the vehicle and/or component used for crash safety may not be modified for the hot air and recirculating air ducting!

**General Instructions**

Installation should be carried out according to the general, standard rules of technology. Unless specified otherwise, fasten hoses, lines and wiring harnesses to original vehicle lines and wiring harnesses using cable ties.

Sharp edges should be fitted with edge protectors (split-open plastic hose).

Spray unfinished body areas, e.g. drilled holes, with anti-corrosion wax (Tectyl 100K, Order No. 111329).

**Heater Units/Installation Kit**

| Quantity | Description   | Order No.: |
|----------|---|------------|
| 1        | Standard Delivery Scope <i>Air Top 2000 ST</i> Gasoline | 9008324C   |
| 1        | Standard Delivery Scope <i>Air Top 2000 ST</i> Diesel   | 9008321C   |
| 1        | Comfort Delivery Scope <i>Air Top 2000 ST</i> Gasoline  | 9008325C   |
| 1        | Comfort Delivery Scope <i>Air Top 2000 ST</i> Diesel    | 9008322C   |
| 1        | Installation kit for VW T5 Gasoline and Diesel          | 9014156A   |

The installation kit contains the bracket with fastening parts.  
The required air ducting parts must be ordered as an option from the Webasto Accessories Catalog in accordance with the customer order!



**To be ordered as an option for vehicles without factory-installed additional heater:**

| Quantity | Description    | Order No.: |
|----------|----------------|------------|
| 1        | Fuel standpipe | 1300823B   |

**To be ordered as an option for vehicles with factory-installed additional heater:**

| Quantity | Description             | Order No.: |
|----------|-------------------------|------------|
| 1        | 6x5x6 mm fuel standpipe | 1310367A   |

**To be ordered as an option when using fresh-air mode:**

| Quantity | Description                 | Order No.: |
|----------|-----------------------------|------------|
| 1        | External temperature sensor | 9005004B   |

**To be ordered as an option when using Telestart:**

| Quantity | Description              | Order No.: |
|----------|--------------------------|------------|
| 1        | Bag for retrofitting T80 | 9014433B   |

The materials used for this application example - in accordance with validity on page 2 - are contained in the following list. In case of deviations in accordance with the customer order, the materials actually required can be ordered from the currently valid Webasto Accessories Catalog.



| Quantity | Description  | Order No.: |
|----------|--|------------|
| 1        | Flexible tube PAK, inside dia.= 60 mm (cut to length)              | 398497     |
| 1        | Flexible tube PAK, inside dia.= 55 mm (cut to length)              | 441376     |
| 5        | Clamp, 50-70 mm dia.   | 139645     |
| 1        | Air outlet, D1a = 60 mm; D2a = 92 mm; L = 65 mm                    | 87389A     |
| 1        | Air outlet, D1a = 55 mm; D2a = 87 mm; 45°                          | 107836     |
| 1        | Distributor with butterfly valve, outside dia.. = 55 mm; L = 95 mm | 101374     |
| 1        | Reducing piece, D1a = 60 mm; D2a = 55 mm; L = 35 mm                | 29852A     |

**Special tools**

- Torque wrench for 2.0 - 10 Nm
- Metric thread-setter kit
- Blind rivet tool

**Explanatory Notes on Document**

To provide you with a quick overview of the individual working steps, you will find an identification mark on the outside top right corner of the page in question.

**Mechanical system**



**Electrical system**



**Hot air system**

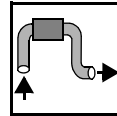

**Fuel connection**



**Exhaust system**

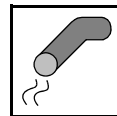

**Combustion air**



Special features are highlighted using the following symbols:



Specific risk of injury or fatal accidents.



Specific risk of damage to components.



Specific risk of fire or explosion.



Reference to general installation instructions of Webasto components or to the manufacturer's vehicle-specific documents.



Reference to a special technical feature.

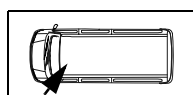
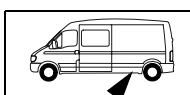

The arrow in the vehicle icon indicates the position on the vehicle and the viewing angle.

General Installation Diagram

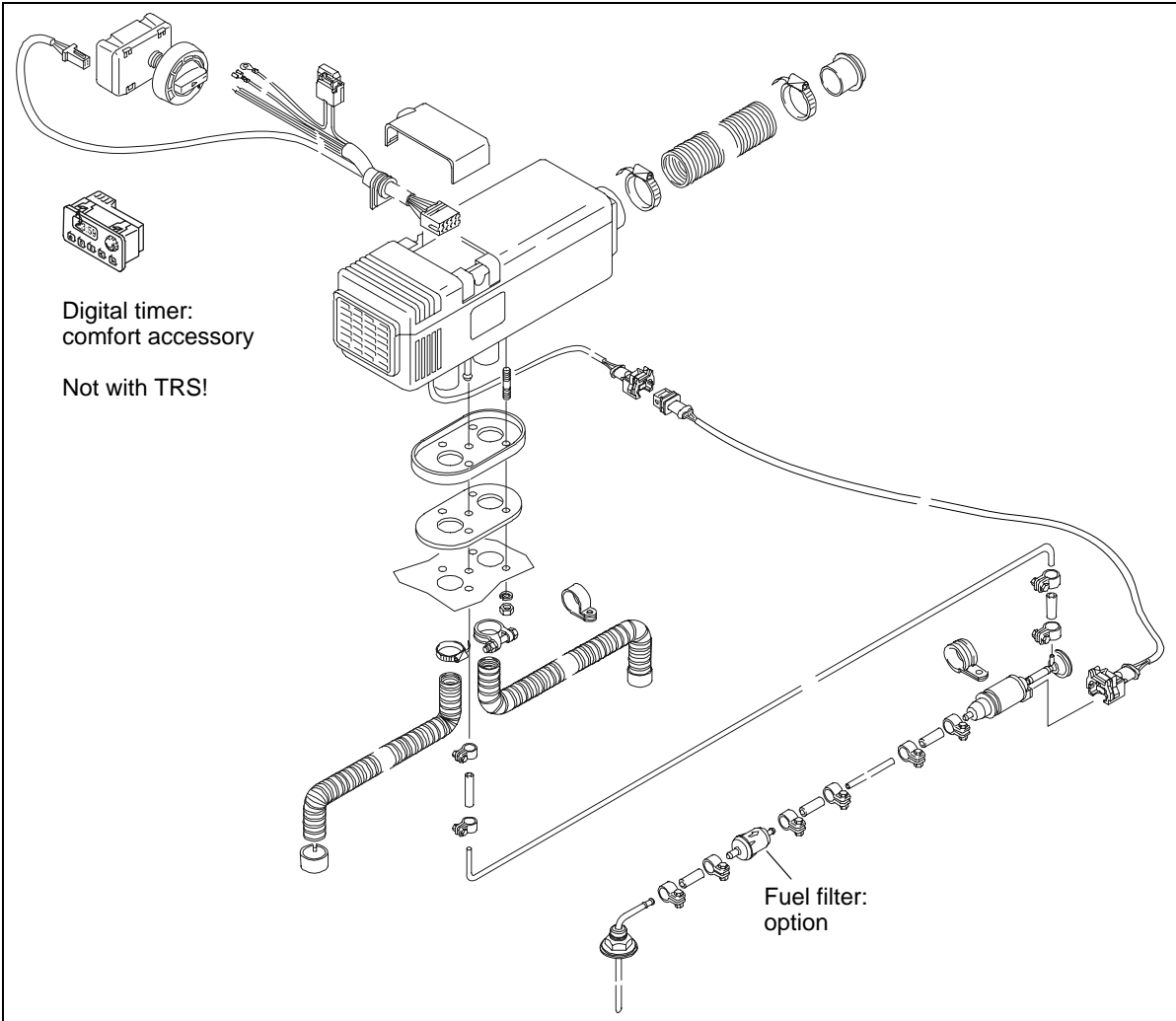

Installation diagram for AT 2000 ST

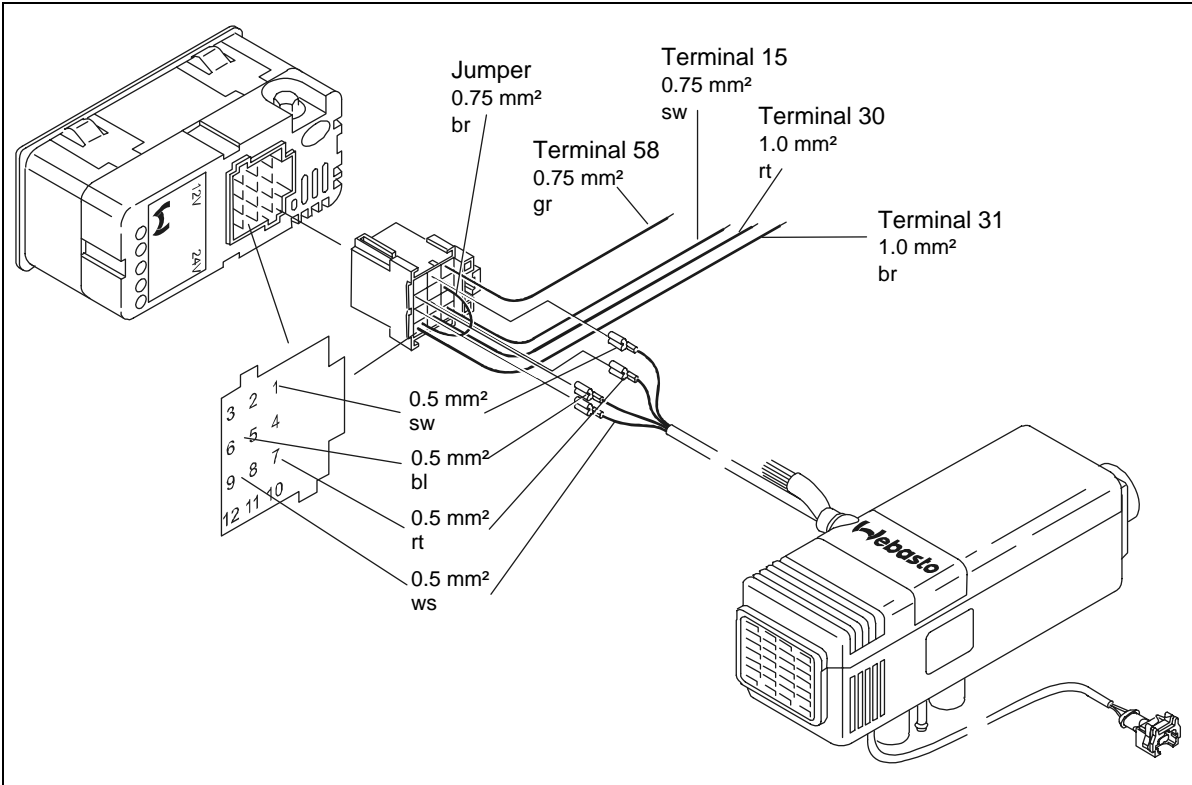

Connection diagram for comfort digital timer

## Preliminary Work

### WARNING!

- Disconnect the battery "earth" or "ground" connection.
- Copy the factory number from the original type label to the duplicate type label.
- Remove years that do not apply from the duplicate label.
- Attach the duplicate label (type label) in the appropriate place.
- Open fuel tank cap, ventilate tank.
- Close the tank cap again.
- Remove the underbody protection on the right and left (if present).
- Remove the fuel tank (only on vehicles without installed auxiliary or additional heater).
- Remove the fuel-tank sending unit in accordance with the manufacturer's instructions (only on vehicles without installed auxiliary or additional heater).
- Remove the trim on the front passenger side entrance (only with recirculating air mode).
- Remove the lower instrument panel trim on the driver's side.

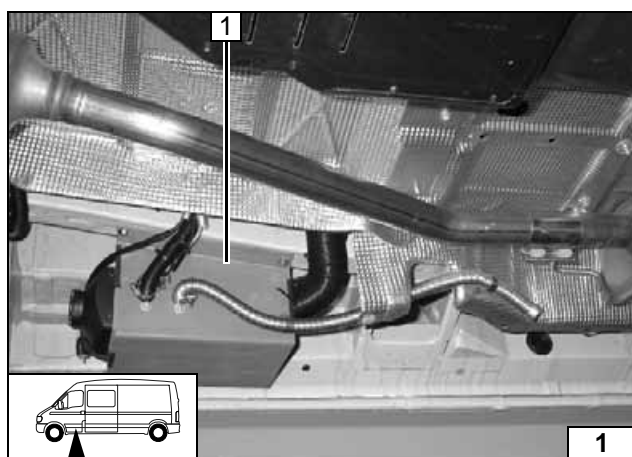

### Heater unit installation location

1 Heater unit

Installation location

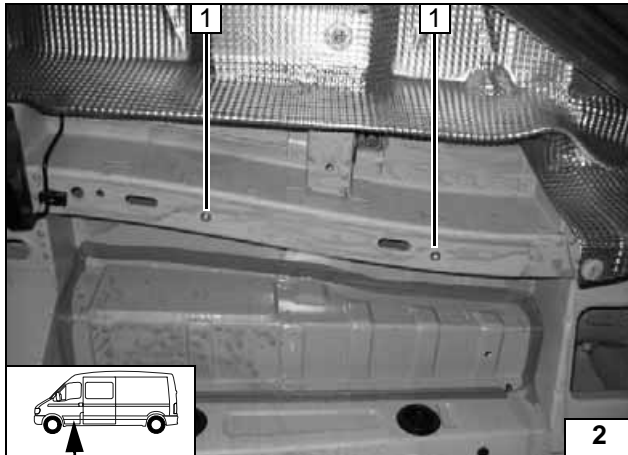
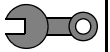

**Preparing installation location**

- 1 Rivet nut (2x) in existing holes

**Installing rivet nuts**

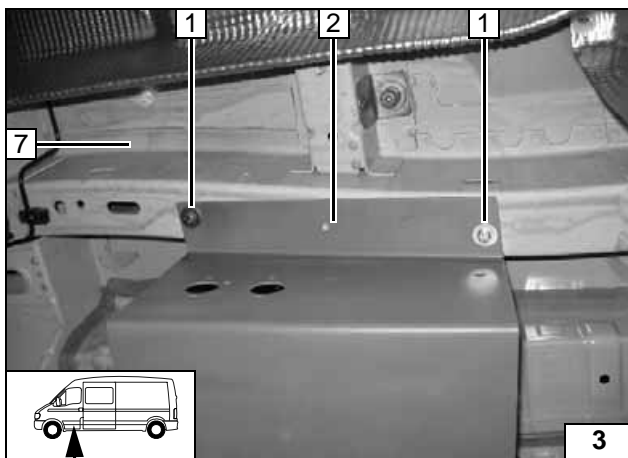

- 2 Bracket
- 1 M6x20 bolt, large diameter washer on rivet nuts

**Loosely mount bracket**

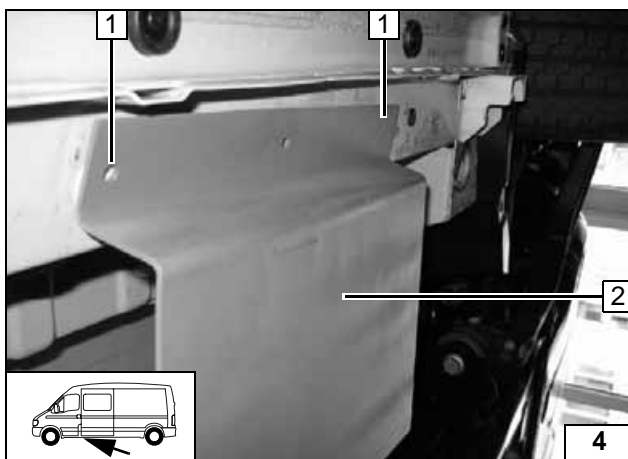

- 1 Copy hole pattern [2x] to door sill
- 2 Remove bracket, drill 9.1 mm dia. hole; install rivet nuts

**Copying hole pattern**

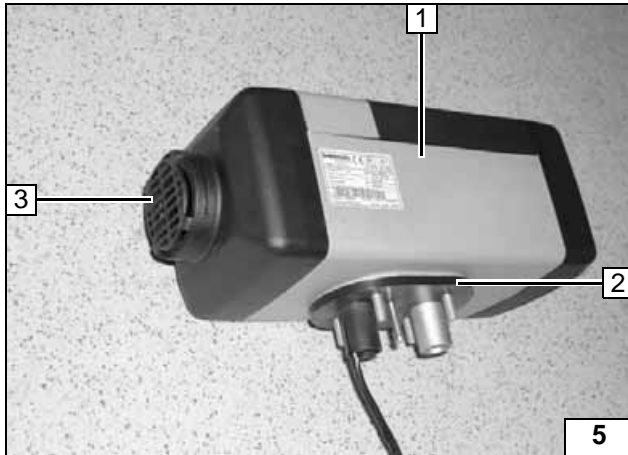
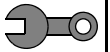

**Preparing heater unit**

With fresh-air mode, an underride protection as shown in Figure 33 must be installed if not present!

- 1 Heater unit
- 2 Mount base seal
- 3 Protective grill



**Preparing heater unit**

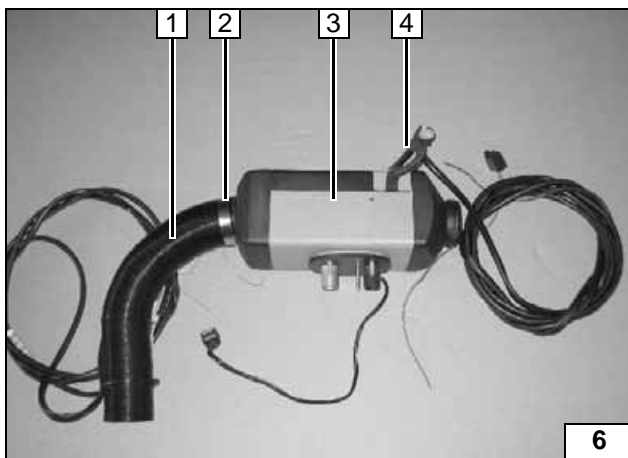

Cut approx. 360 mm off 60 mm dia. flexible tube.

- 3 Heater unit
- 4 Wiring harness
- 1 60 mm dia. flexible pipe, 360 mm long
- 2 50-70 mm dia. hose clamp



**Premounting heater unit**

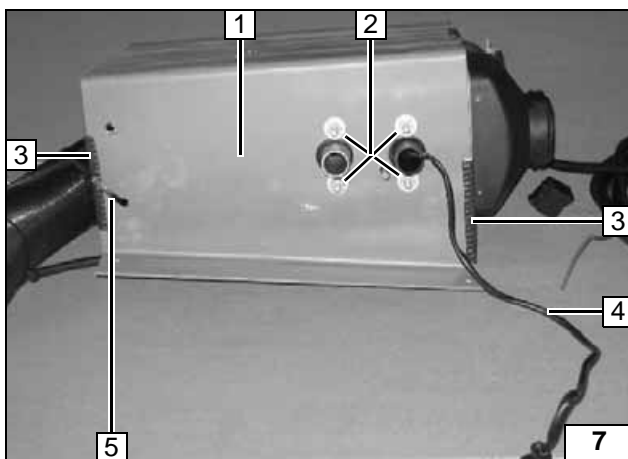

Route through wire of metering pump 4 downward.  
Fasten hot-air flexible tube on bracket with cable tie.

- 1 Bracket
- 2 Large diameter washer, spring lockwasher, M6 nut [4x each]
- 3 Mount edge protection, 70 mm long [2x]
- 5 Cable tie



**Installing bracket**

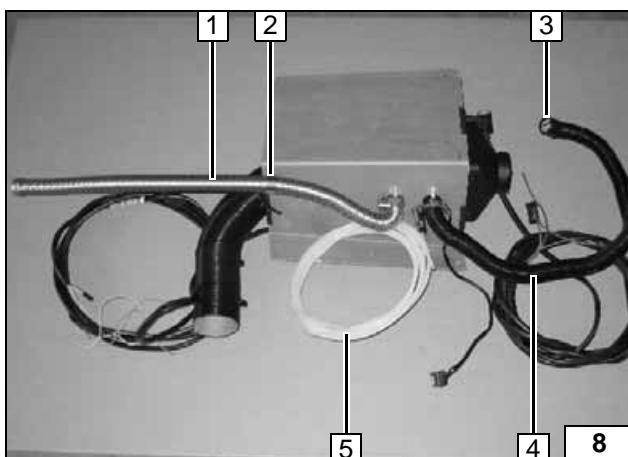

- 1 Exhaust pipe, hose clamp
- 2 P-clamp, 10 mm spacer sleeve, M6x20 bolt, flanged nut
- 4 Combustion-air intake pipe, 27 mm dia. hose clamp
- 3 Protective cap
- 5 Mecanyl fuel line, hose section, 10 mm dia. hose clamp [2x]



**Installing lines**



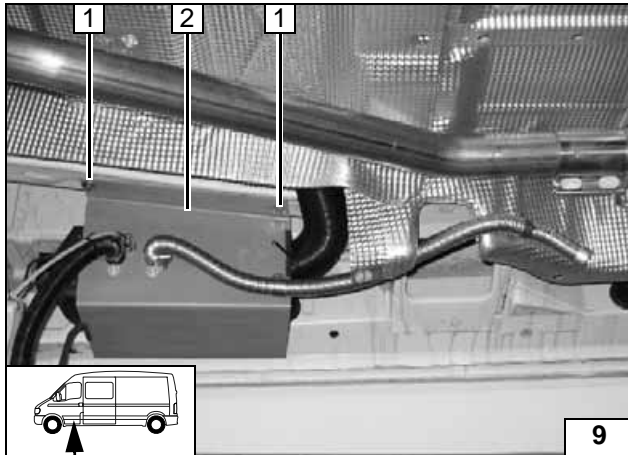
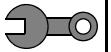

**Installing heater unit**

- 2 Preassembled heater unit
- 1 M6x20 bolt, spring lockwasher, flanged nut [2x each]

Installing heater unit

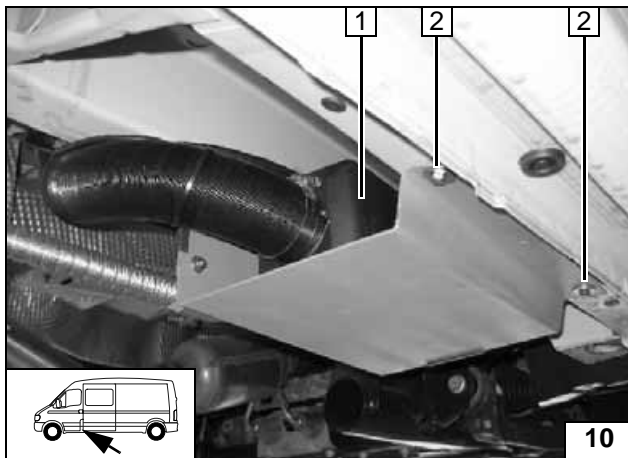

- 1 Preassembled heater unit
- 2 M6x20 bolt, spring lockwasher, flanged nut [2x each]

Installing heater unit

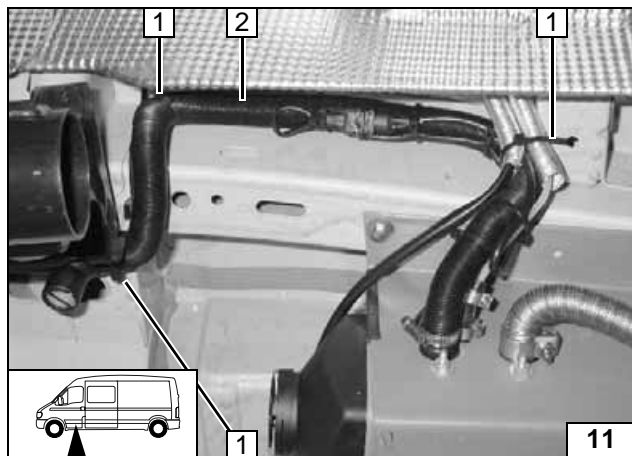

### Combustion air

Shape combustion-air intake pipe as shown in picture.

- 2 Combustion-air intake pipe
- 1 Cable tie



Installing intake pipe



## Fuel Connection

### CAUTION!

Open the vehicle's fuel tank cap, ventilate the tank and then re-close the tank lock.

Catch any fuel running off with an appropriate container.

Install fuel line and metering-pump wiring harness so that they are protected against stone impact. Unless specified otherwise, always fasten using cable ties.

Mount the fuel line and wiring harness with rub protection on sharp edges.

### WARNING!

The fuel line and wiring harness are routed to the metering pump in as shown in the wiring harness routing diagram.

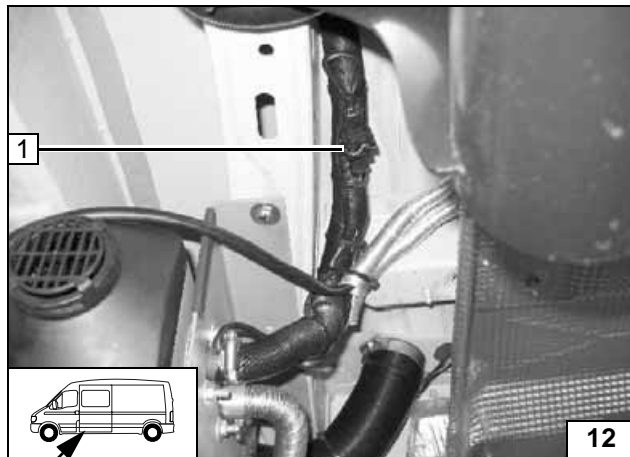

Complete connector with single wire seal [2x], tab connector and connector housing on wire of metering pump from heater unit and connect to wiring harness of metering pump.

- 1 Plug connection on wiring harness of metering pump

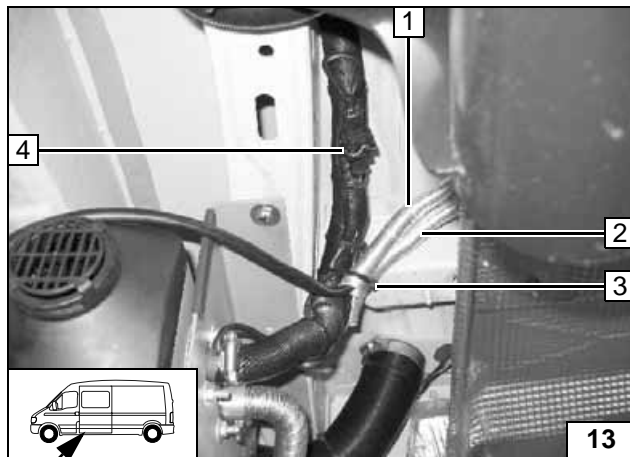

Cut heat protection hose as shown in Figure 12 and 13. Pull wiring harness of power supply and wiring harness of metering pump and Mecanyl fuel line into one heat protection hose each.

- 1 Wiring harness of power supply in heat protection hose
- 2 Mecanyl fuel line and wiring harness of metering pump in heat protection hose
- 3 Cable tie

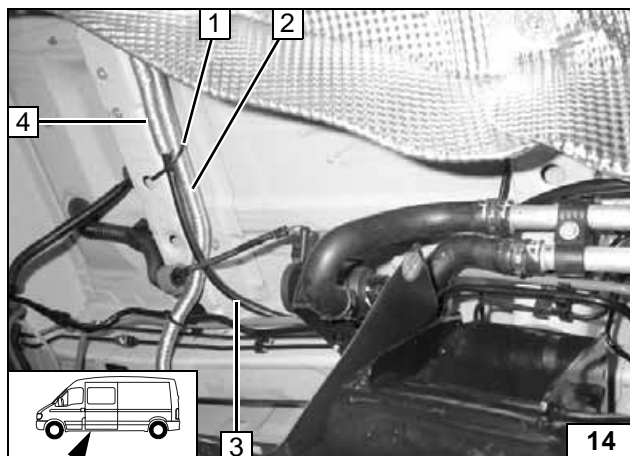

Route wiring harness of power supply and wiring harness of metering pump and Mecanyl fuel line over heat guard plate on left-hand side of vehicle. Route wiring harness of power supply further to battery.

- 4 Wiring harness of power supply in heat protection hose
- 2 Mecanyl fuel line and wiring harness of metering pump in heat protection hose
- 3 Wiring harness of power supply
- 1 Cable tie



Connect-  
ing wiring  
harness of  
metering  
pump



Installing  
lines



Installing  
lines

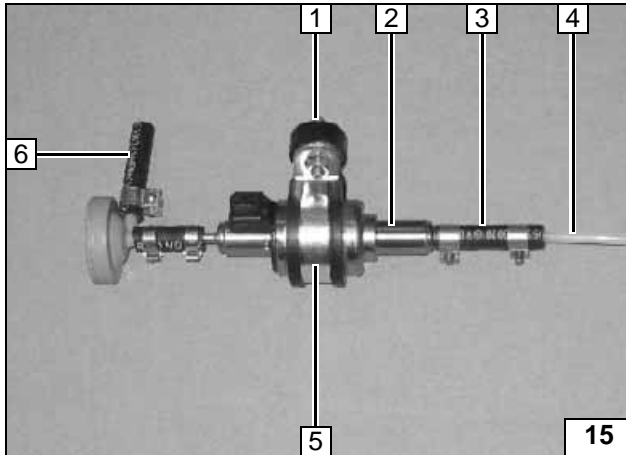

### Metering pump

Cut Mecanyl fuel line to length at installation location of metering pump.

- 2 Metering pump
- 5 Rubber-coated pipe clamp
- 1 Silentblock, flanged nut
- 4 Hose section, 10 mm dia. hose clamps [2x]
- 6 Hose section, 10 mm dia. hose clamp
- 4 Remaining end of Mecanyl fuel line
- 3 Hose section, 10 mm dia. hose clamps [2x]

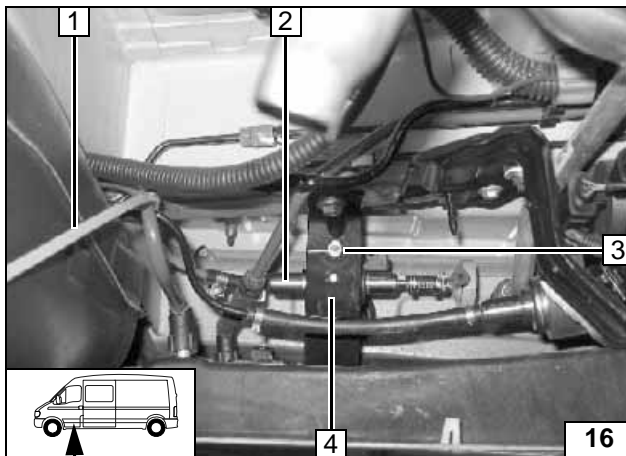

Ensure proper installation position of metering pump, see "Installation Instructions". Installation location on left on strut before vehicle fuel tank!

- 2 Preassembled metering pump
- 3 Flanged nut on silent block in existing hole
- 4 Original vehicle strut
- 1 Remaining end of Mecanyl fuel line

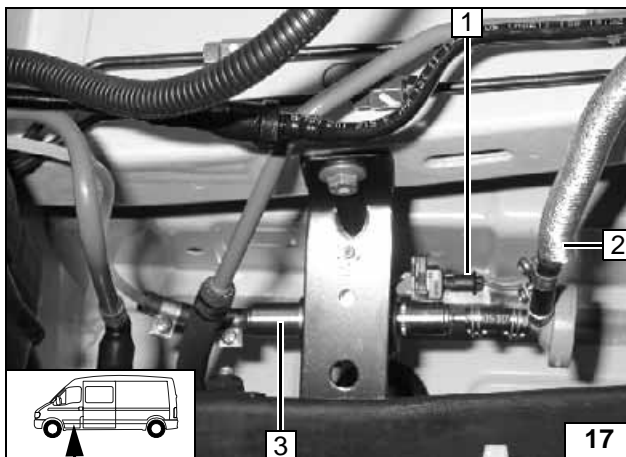

Fuel line from heater unit on pressure side of metering pump [side with connector].

- 3 Preassembled metering pump
- 1 Wiring harness for metering pump, single-wire sealing [2x], tab connector, connector housing
- 2 Fuel line from heater unit, 10 mm dia. hose clamp on premounted hose section



**Preassembling metering pump**



**Installation location of metering pump**

**Connecting metering pump**

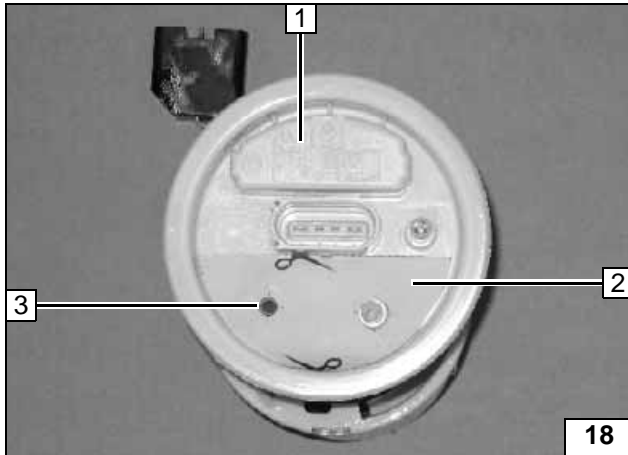

**Fuel Removal on Vehicles without Additional or Auxiliary Heater**

Remove fuel tank according to manufacturer's specifications. Remove fuel-tank sending unit according to manufacturer's specifications.  
Cut out template and lay on.

- 1 Fuel-tank sending unit
- 2 Template
- 3 Copy hole pattern, 6 mm dia. hole

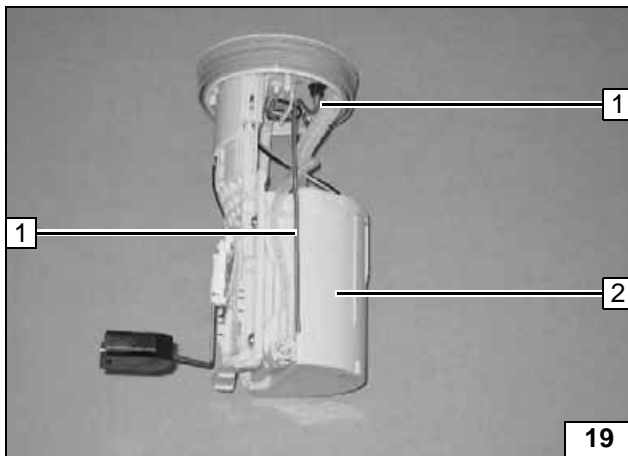

Shape fuel standpipe according to template, cut to length and install, see "installation instructions".

- 2 Fuel-tank sending unit
- 1 Fuel standpipe

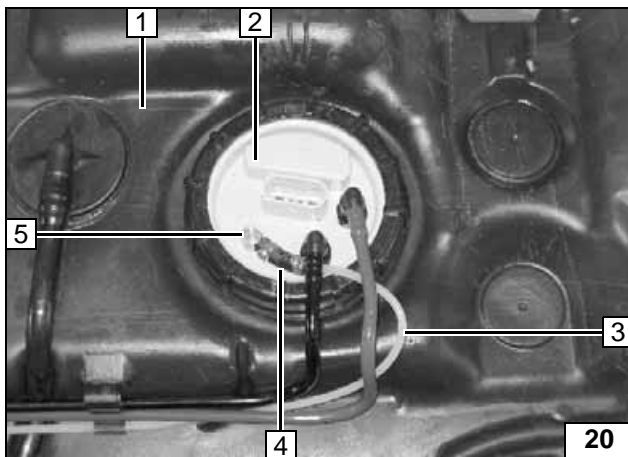

Install fuel-tank sending unit according to manufacturer's specifications.

- 1 Fuel tank
- 2 Fuel-tank sending unit
- 5 Fuel standpipe
- 3 Remaining end of Mecanyl fuel line
- 4 Hose section, 10 mm dia. Caillau clamp [2x]

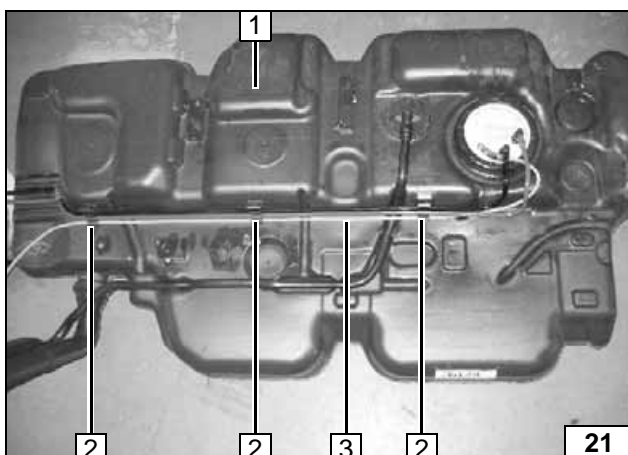

Clip fuel line from fuel standpipe 3 into existing fastening points 2. Remount fuel tank.

- 1 Fuel tank
- 3 Remaining end of Mecanyl fuel line
- 2 Fastening points [3x]



**Removing fuel**



**Installing fuel standpipe**



**Connecting fuel line**



**Installing fuel line**

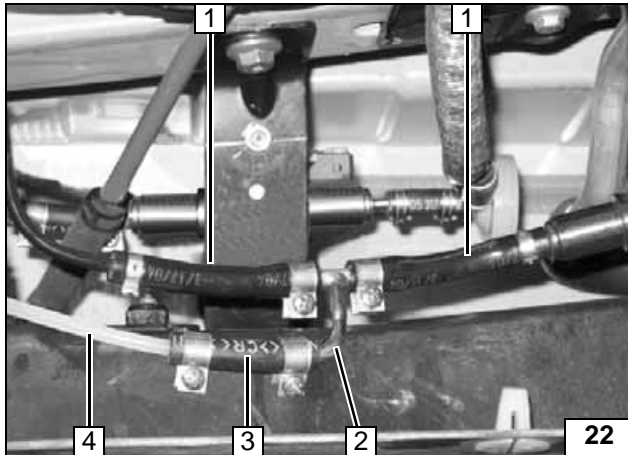

### Fuel Removal on Vehicles with Additional or Auxiliary Heater

Cut off fuel line to additional or auxiliary heater as shown.  
Mount fuel standpipe in cutting point as shown.

- 1 Fuel line to additional or auxiliary heater
- 2 Fuel standpipe, 10 mm dia. hose clamp [2x].
- 4 Remaining end of Mecanyl fuel line from metering pump
- 3 Hose section, 10 mm dia. hose clamp [2x]



**Removing fuel**

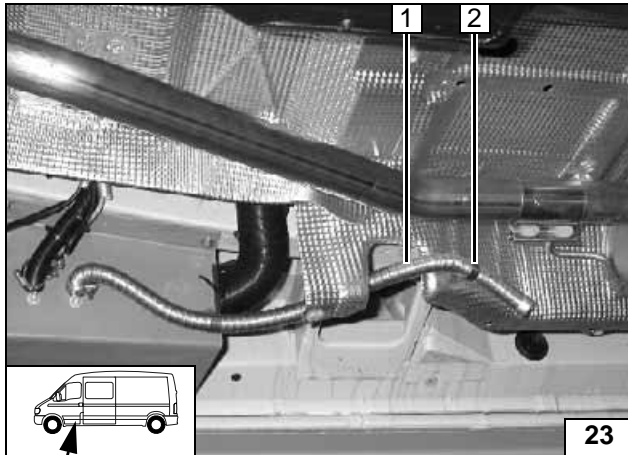
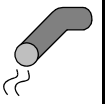

**Exhaust system**

Align exhaust pipe as shown.  
Drill 2 mm dia. condensed-water drain hole at lowest point in exhaust pipe.  
Ensure sufficient distance to neighboring components.

- 1 Exhaust pipe
- 2 P-clamp, 10 mm spacer sleeve, self-tapping screw



**Fastening exhaust pipe**

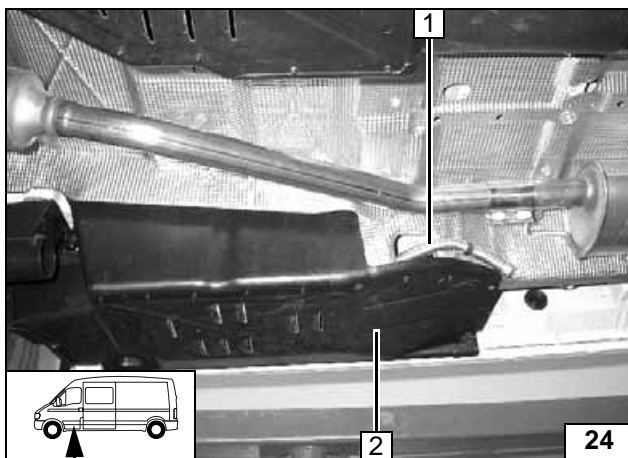

**Optional Exhaust Muffler**

Installation of exhaust muffler as shown in Figure 26 is not possible on a vehicle with underdrive protection equipment!

- 1 Exhaust pipe
- 2 Underdrive protection



**Exhaust muffler**

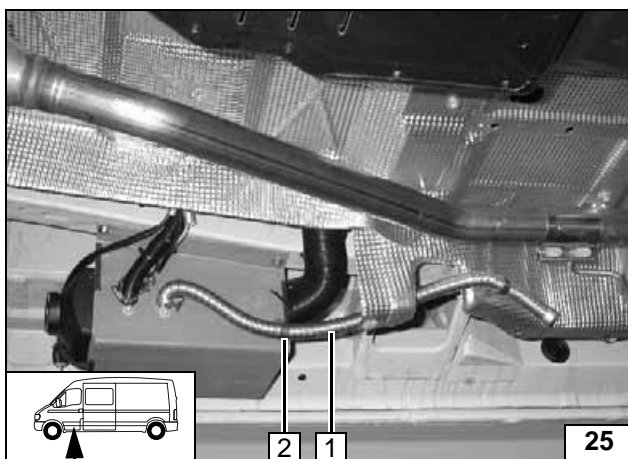

Remove p-clamp at position 2 again.

- 1 Exhaust pipe
- 2 P-clamp



**Removing p-clamp**

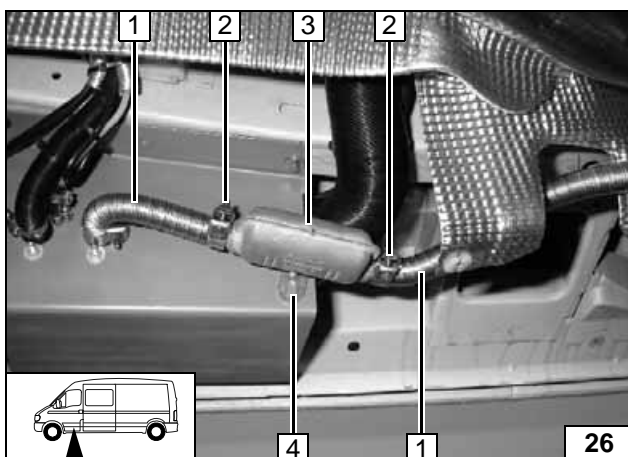

Cut off exhaust pipe as shown in Figure and mount muffler.

- 1 Exhaust pipe
- 5 Angle bracket, M6x20 bolt, flanged nut on bracket
- 3 Exhaust muffler, M6x20 bolt, flanged nut on angle bracket
- 2 Hose clamp [2x]



**Installing muffler**

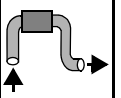

### Optional Hot Air System

**WARNING!**

The routing of the air ducting parts shown is an application example on the van with a partition wall. Should other versions and equipment variants be used, then the appropriate adjustments must be made. Before installation, the routing of the air ducting parts must be coordinated with the end customer!

Install flexible tubes so that they are kink-free. Unless specified otherwise, always fasten using brackets and cable ties.

The hot air ducting on this version example is executed as shown in the following diagram:

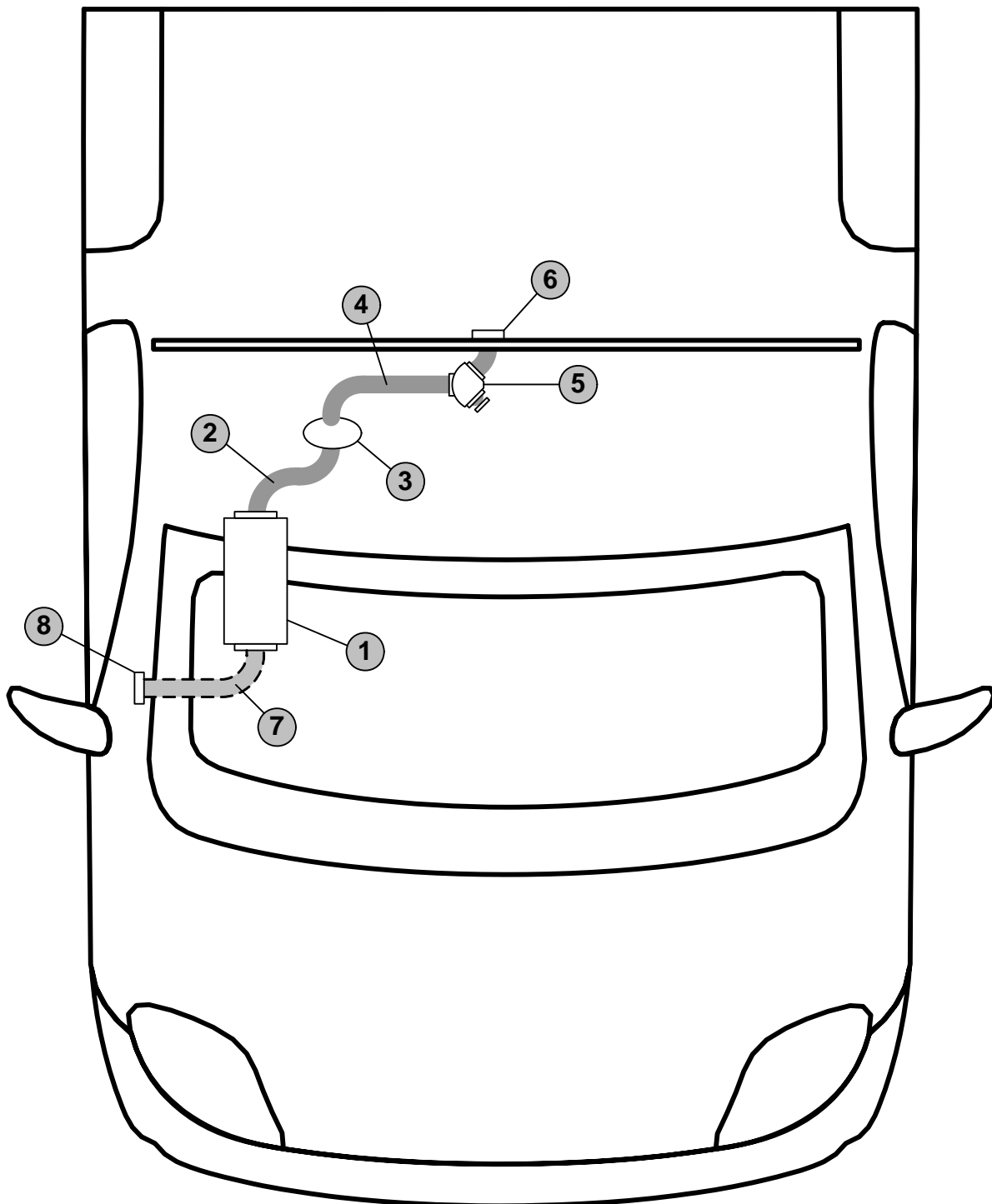
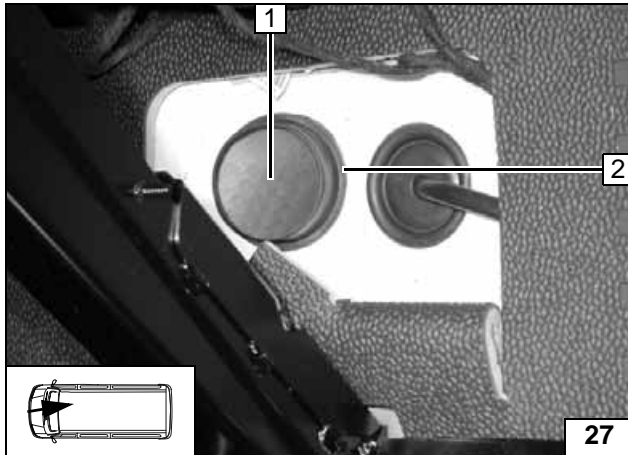
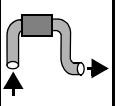

Diagram for hot air ducting

- 1 = Heater unit
- 2 = Flexible tube, 60 mm dia.
- 3 = Dia. 55x60 mm adapter
- 4 = Flexible tube, 55 mm dia.
- 5 = Air distributor
- 6 = Air outlet
- 7 = Flexible tube, 60mm dia.
- 8 = Air outlet







**Optional Hot Air System**

Fold back cover under front passenger seat. Lay on dia. 55x60 adapter as shown.

- 2 Dia. 55x60 mm adapter
- 1 Copy hole pattern, 60 mm dia. hole



**Hole under front passenger seat**

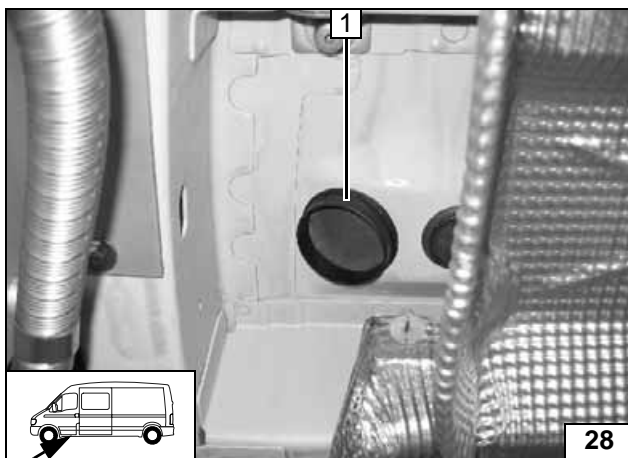

Mount adapter in hole from above and glue in with Sicaflex.

- 1 Dia. 55x60 mm adapter



**Gluing in adapter**

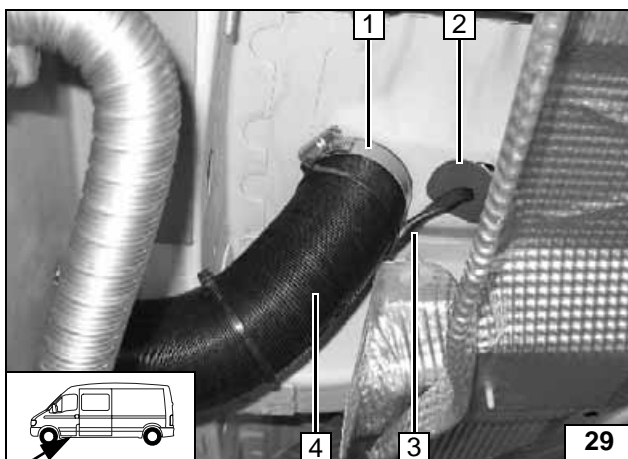

Mount 60 mm dia. flexible tube on adapter. Route wiring harness of controls through protective rubber plug into passenger compartment.

- 4 60 mm dia. flexible pipe, 360 mm long
- 1 50-70 mm dia. hose clamp [2x]
- 3 Wiring harness of controls
- 2 Protective rubber plug



**Pass throughs into passenger compartment**

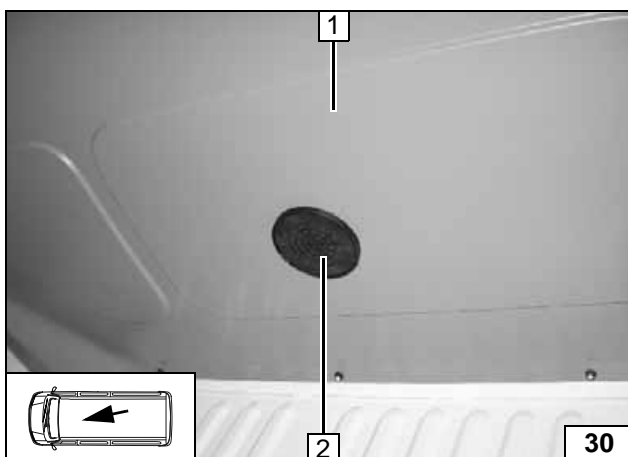

55 mm dia. hole at position 2 in partition wall. Mount air outlet and fasten with blind rivets.

- 1 Partition wall
- 2 Air outlet



**Hole in partition wall**

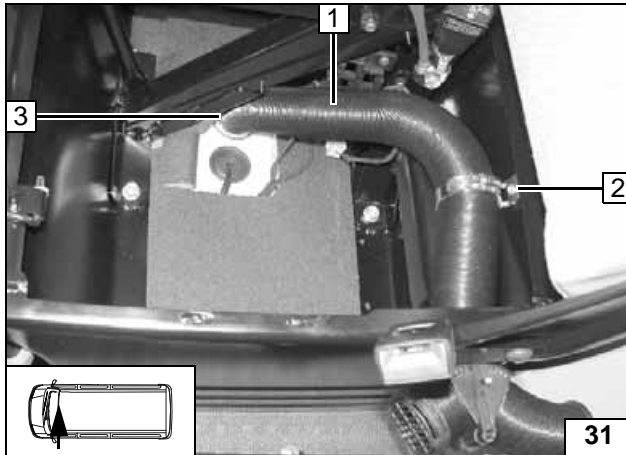
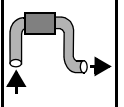

Cut 55 mm dia. flexible tube **1** to length as shown and mount on adapter **3**.

- 1** 55 mm dia. flexible tube
- 3** 50-70 mm dia. hose clamp
- 2** Bracket with hose clamp, self-tapping screw [2x]



**Routing under front passenger seat**

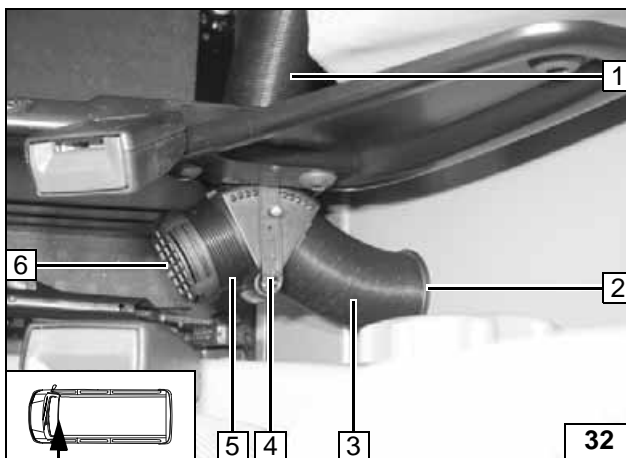

Cut 55 mm dia. flexible tube **3** and **5** to length as shown. Mount air distributor as shown. Air outlet must be aligned so that hot air is not directed at controls (e.g. handbrake lever)!

- 1** 55 mm dia. flexible tube from Adapter
- 4** Air distributor, adjustable
- 3** 55 mm dia. flexible tube to air outlet
- 5** 55 mm dia. flexible tube
- 2** Air outlet
- 6** End cap



**Mounting distributor**

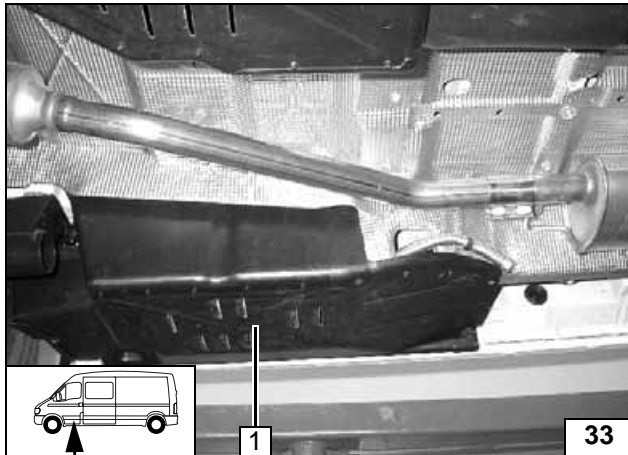
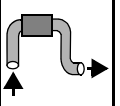

**Optional Recirculating Air**

No underride protection is required for the option recirculating air mode!

- 1 Underride protection



**Underride protection**

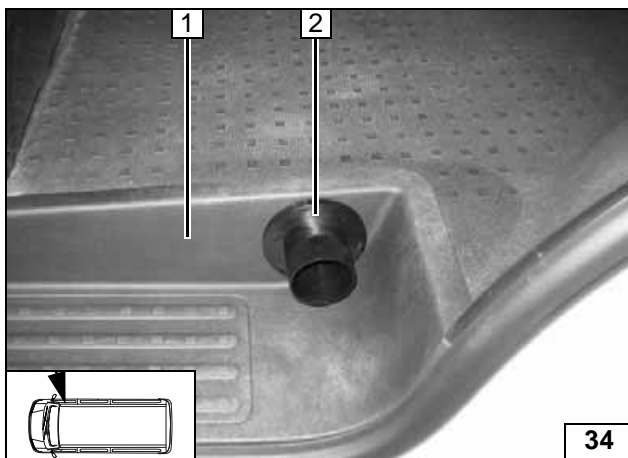

Lay air outlet on entrance trim on front passenger side as shown; copy inside dia. and hole pattern for fastening [3x] to trim. Remove air outlet and drill 60 mm dia. hole in trim and entrance on front passenger side.

- 1 Entrance trim on front passenger side
- 2 Air outlet



**Installing air outlet**

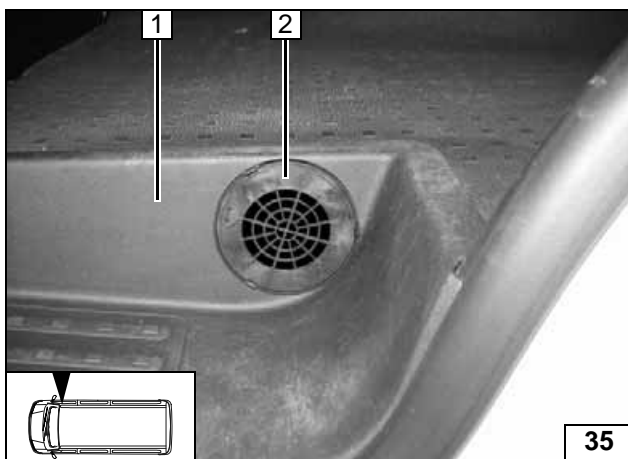

Hole for fastening air outlet [3x] in trim. Mount air outlet in trim and fasten with blind rivets.

- 1 Entrance on front passenger side
- 2 Air outlet



**60 mm dia. hole in entrance**

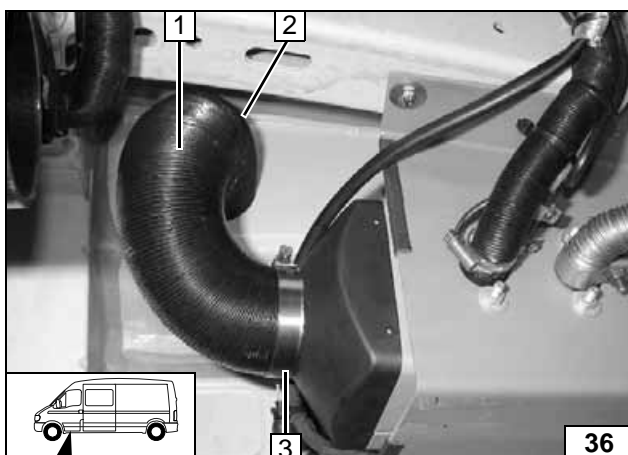

Remove protective grill at position 3. Cut 60 mm dia. flexible tube 1 to length as shown and mount on air outlet 3. Seal off pass through at position 2 with Sicalflex.

- 1 60 mm dia. flexible tube
- 2 Air outlet
- 3 50-70 mm dia. hose clamp



**Installing intake hose**

Following installation, seal off pass through at position 2 with Sicalflex.



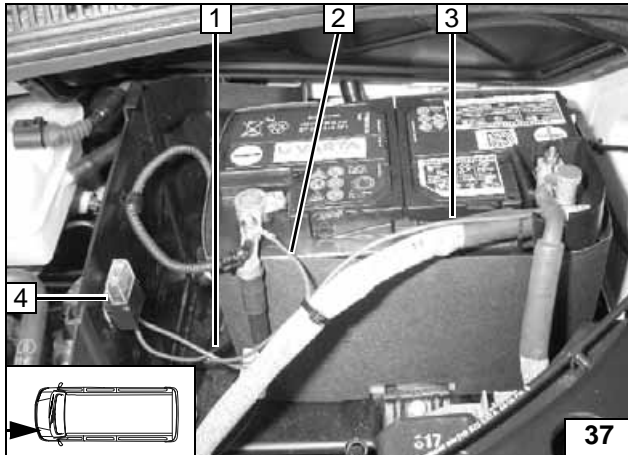

**Electrical Connections**

- 4 Fuse holder retaining plate, M4x12 bolt, washer, M4 nut
- 1 Wiring harness of power supply for heater unit
- 2 Ground wire on negative battery terminal
- 3 Positive wire on positive battery terminal

**Installing fuse holder**

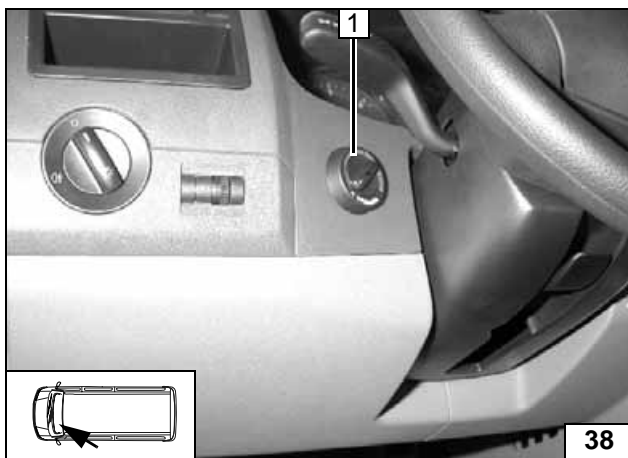

- 1 Thermostat



**Installing heater control**

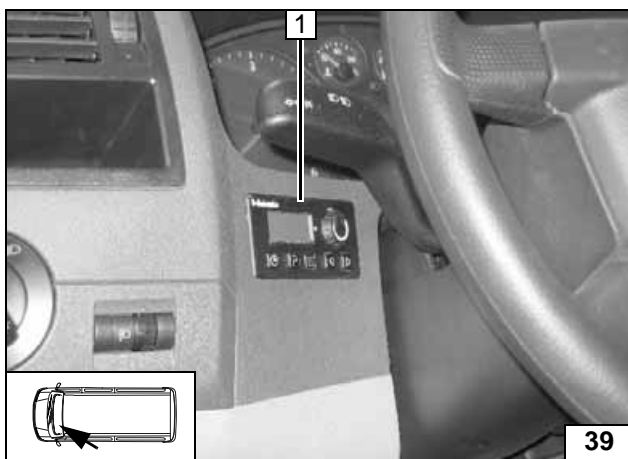

**Combination timer option**

- 1 Combination timer



**Installing combination timer**

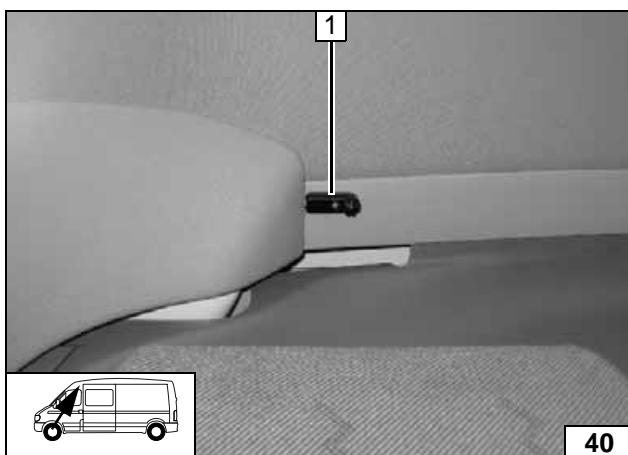

**External temperature sensor**

Installation is not carried out in recirculating air mode!

- 1 External temperature sensor



**Installing temperature sensor**



**Remote option (Telestart)**

Connect receiver for Telestart as shown in wiring diagram.

- 1 M5x16 bolt, flanged nut on existing hole
- 2 Telestart
- 3 Telestart bracket



**Installing receiver**

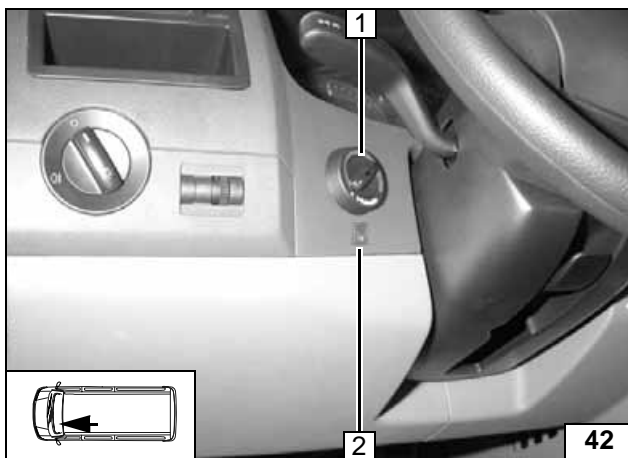

Only applies for combination of standard heater control with Telestart!  
Connect switch as shown in wiring diagram.

- 1 Standard heater control
- 2 Switch



**Installing switch**

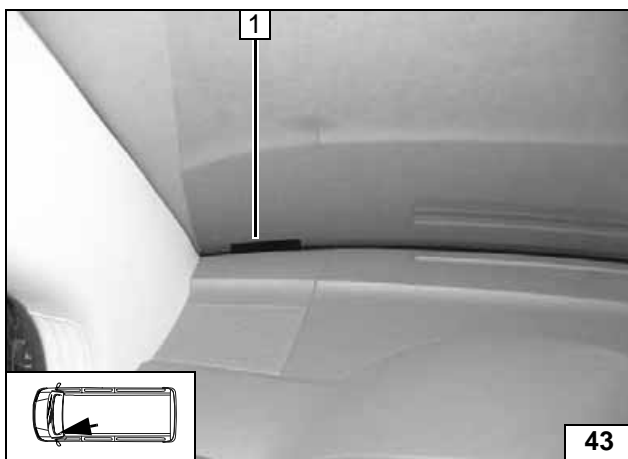

- 1 Antenna

**Installing antenna**

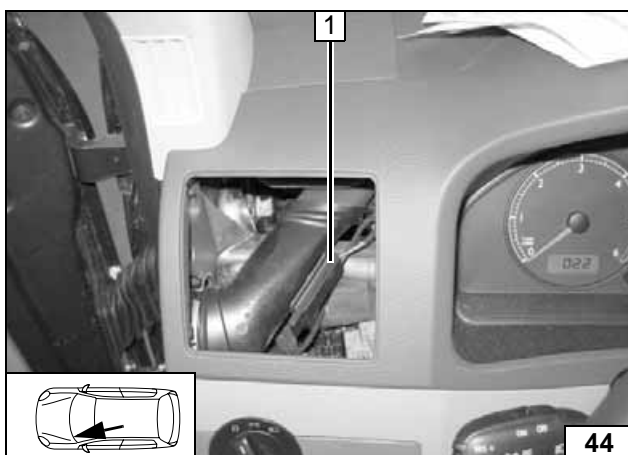

**Only with Telestart HTM 100**

- 1 Fasten temperature sensor with double-sided adhesive tape

**Installing temperature sensor**



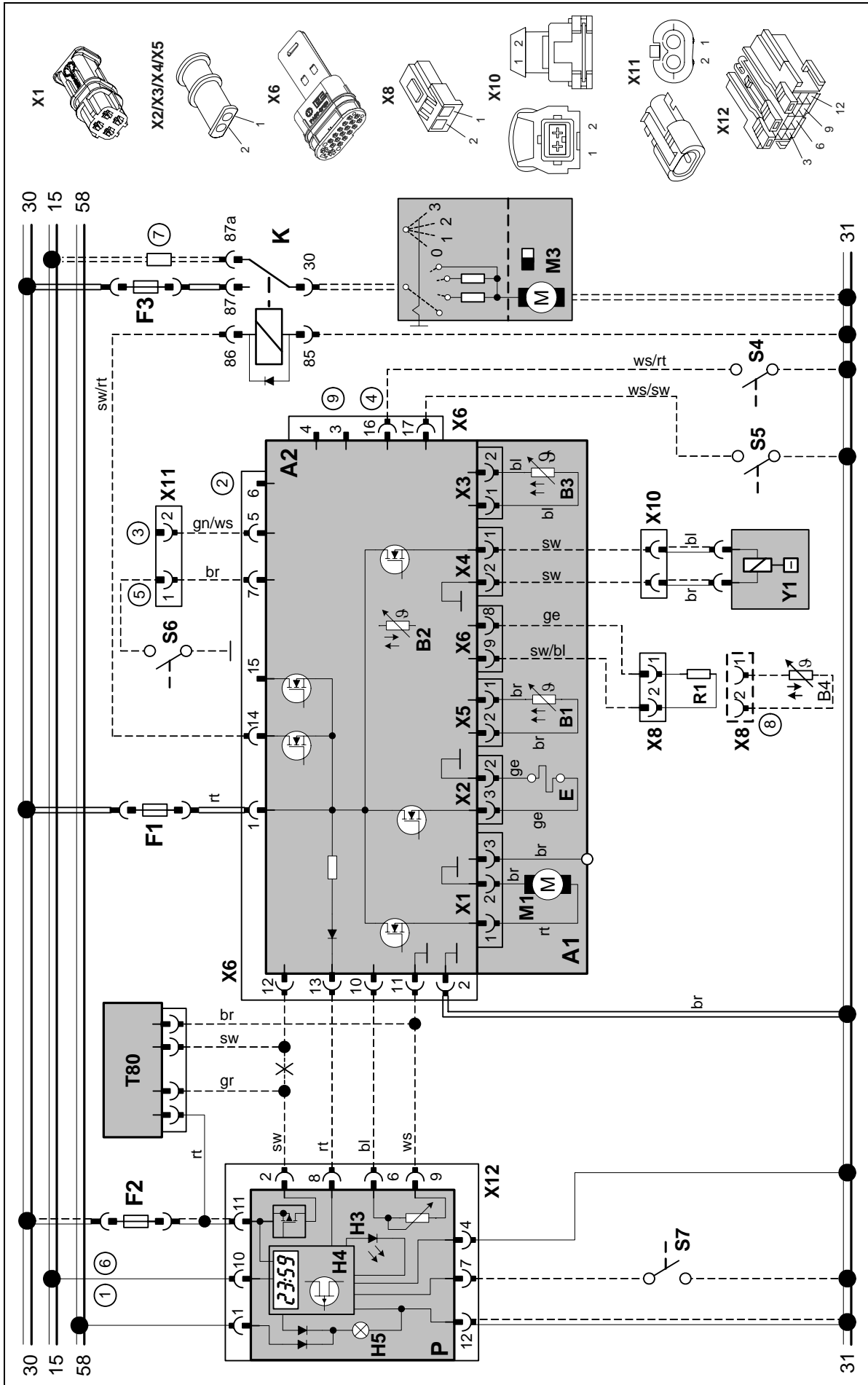

System wiring diagram with combination timer, Telestart and vehicle fan



|   |   |
|---|---|
| ① | <b>With positive wire from terminal (15/75) to connection 10:</b><br>Continuous operation with immediate heating as long as ignition is switched on<br><b>Without positive wire on connection 10:</b><br>Heating time is variably programmable (10 min. to 120 min.), default setting is 120 min. |
| ② | K-wire diagnosis  |
| ③ | W bus   |
| ④ | Input pin (Pin 16/Connector X6, wire color on wiring harness: white/red (ws/rt)):<br>"Ventilate" (fan speed is dependent on position of heater control)   |
| ⑤ | CO <sub>2</sub> setting (see workshop manual)   |
| ⑥ | <b>NOTE:</b><br>If a connection is made to Terminal 30, continuous heating operation is possible with ignition switched off! In this case, no connection may be made to Terminal 15/75!   |
| ⑦ | Fuse present in vehicle   |
| ⑧ | If an external temperature sensor (B4) is used, then the resistor R1 is replaced with the temperature sensor (B4)   |
| ⑨ | Connection only for ADR vehicles  |
| ⑩ | <b>NOTE:</b><br>Gray (gr) and violet (vi) wires required for ADR function   |
| ⑪ | Stop signal for battery isolator switch. The stop input (if present) of the isolator switch (S2) must be connected to the control unit, Pin 15/Connector X6   |

Legend for  
Wiring Dia-  
grams

| Wiring Colors |        |
|---------------|--------|
| rt            | red    |
| gr            | gray   |
| sw            | black  |
| br            | brown  |
| gn            | green  |
| bl            | blue   |
| ge            | yellow |
| or            | orange |
| vi            | violet |
| ws            | white  |

| Wiring Cross-Sections |                      |                      |
|-----------------------|----------------------|----------------------|
|                       | < 7.5 m              | 7.5 - 15 m           |
| - - - - -             | 0.5 mm <sup>2</sup>  | 0.75 mm <sup>2</sup> |
| =====                 | 0.75 mm <sup>2</sup> | 1.0 mm <sup>2</sup>  |
| - - - - -             | 1.0 mm <sup>2</sup>  | 1.5 mm <sup>2</sup>  |
| =====                 | 1.5 mm <sup>2</sup>  | 2.5 mm <sup>2</sup>  |
| =====                 | 2.5 mm <sup>2</sup>  | 4.0 mm <sup>2</sup>  |
| =====                 | 4.0 mm <sup>2</sup>  | 6.0 mm <sup>2</sup>  |

Legend for  
Wiring Dia-  
grams





| Pos. | Name                                  | Remarks   |
|------|---------------------------------------|---|
| A1   | Heater unit                           | Air Top 2000 ST   |
| A2   | Control unit                          |   |
| B1   | Flame detector                        | Only on gasoline unit   |
| B2   | Temperature sensor                    | Internal  |
| B3   | Overheating sensor                    | Overheating protection  |
| B4   | Temperature sensor                    | External  |
| E    | Glow element                          |   |
| F1   | 24 V 15 A/12 V 20 A fuse              | Blade fuse, SAE J 1284  |
| F2   | Fuse, 3 A                             | Blade fuse, SAE J 1284  |
| F3   | 25 A fuse                             | Blade fuse, SAE J 1284  |
| H1   | LED, green (in Pos. S1)               | Operation indicator   |
| H3   | LED, red (in Pos. P)                  | Lighting for immediate heating button, ready display, switch-on check |
| H4   | Heating symbol in display (in Pos. P) | Operation indicator   |
| H5   | Lamps (in Pos. P)                     | Display and button lighting   |
| H6   | Lamp (at least 1.2 W)                 | Switch-on check for feed device                                       |
| K    | Relay with freewheeling diode         | For vehicle fan   |
| M1   | Engine                                | Combustion and hot air fan  |
| M3   | Engine                                | Vehicle fan   |
| P    | Combination digital timer (1531)      | Digital timer and setpoint encoder                                    |
| R1   | Resistor 620 $\Omega$                 | Only with internal temperature sensor                                 |
| S1   | Heater control                        | Setpoint encoder switch   |
| S2   | Isolator switch, 1 or 2-pin           | Emergency-Stop-switch   |
| S3   | Switch                                | On and for feed device  |
| S4   | Switch                                | Ventilation   |
| S5   | Switch                                | Rollover sensor   |
| S6   | Switch                                | CO <sub>2</sub> setting   |
| S7   | Momentary-contact switch              | Immediate heating button on remote control                            |
| S8   | Battery isolator switch               |   |
| S9   | Additional switch                     | Telestart switch-off function   |
| V1   | Diode                                 |   |
| V2   | Diode                                 |   |
| X1   | Plug connection, 2-pin                | At Pos. A2 (ST B)   |
| X2   | Plug connection, 2-pin                | At Pos. A2 (ST V)   |
| X3   | Plug connection, 2-pin                | At Pos. A2 (ST U)   |
| X4   | Plug connection, 2-pin                | At Pos. A2 (ST Z)   |
| X5   | Plug connection, 2-pin                | At Pos. A2 (ST Y)   |
| X6   | Plug connection, 2-pin                | At Pos. A2 (ST X)   |
| X7   | Plug connection, 12-pin               | At Pos. A2 (ST1)  |
| X8   | Plug connection, 2-pin                |   |
| X9   | Plug connection, 4-pin                | At Pos. S1  |
| X10  | Plug connection, 2-pin                |   |
| X11  | Plug connection, 2-pin                | At Pos. Y1  |
| X12  | Plug connection, 12-pin               | At Pos. P   |
| Y1   | Metering pump                         |   |
| Y2   | Solenoid valve                        | For feed device   |

Legend for  
Wiring Dia-  
grams



## Shut-down on fault

Faults in individual heater unit components and malfunctions during the entire operation are recognized in the control unit.

The heater unit is shut down (fault lock-out) if:

- No or faulty start-up
- Temperature sensor defective
- Open or short circuit in overheating sensor
- Overheating sensor mounted incorrectly
- Break or short circuit in glow element
- Fan motor overloaded, blocked, short circuit or open circuit
- Fault in metering pump circuit or overheating protection (only during start-up phase)
- Undervoltage < 10.5 V or overvoltage >16 V and longer than 20 sec. (on heater unit with 12 V)
- Undervoltage < 21 V or overvoltage >32 V and longer than 20 sec. (on heater unit with 24 V)
- Control unit defective
- Overheating
- Flame detector (only on gasoline heater units)

In case of overheating, the fuel feed is interrupted. A run-on is carried out as with manual shut-down. Following the run-on, the heater unit is in the fault lock-out mode. The overheating is indicated by the operation indicator flashing 10 times.

Eliminate fault cause.

For fault release, briefly switch the heater unit off and then on again (at least 2 sec.).

If serious malfunctions, such as overheating, or no start-up occurs increasingly frequently, then the heater unit is permanently locked (F12 or F13) and can only be returned to operation following repairs by specially trained Webasto experts.

## Fault code output:

### Note:

When equipped with a heater control, fault code output is carried out after a malfunction occurs by the switch-on check/fault code display flashing. After 5 rapid flashing pulses, the fault code output is carried out with a sequence of long flashing pulses in accordance with the numbers in the table below. When equipped with a combination timer, a fault output appears in the display of the digital timer after a fault occurs. When using the heater control, the fault number is indicated by the operating indicator lamp flashing:

| Display | Fault Code  |
|---------|---|
| F00     | Control unit fault/incorrect data record/customer bus faulty      |
| F01     | No start-up (after 2 starting attempts)/no flame formation        |
| F02     | Flame failure (repeated >3)                                       |
| F03     | Undervoltage or overvoltage                                       |
| F04     | Premature flame detection   |
| F05     | Flame detector (gasoline heater unit) open or short circuit       |
| F06     | Open or short circuit in temperature sensor                       |
| F07     | Open or short circuit in metering pump                            |
| F08     | Open circuit, short circuit, overloading or blocking in fan motor |
| F09     | Break or short circuit in glow element                            |
| F10     | Overheating: As a result, continuous heater unit lock-out         |
| F11     | Open or short circuit in overheating sensor                       |
| F12     | Heater unit lock-out  |
| F13     | Continuous heater unit lock-out                                   |
| F14     | Overheating sensor in incorrect position                          |
| F15     | Open circuit in setpoint encoder                                  |



Legend for  
Fault Code  
Output

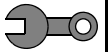

## Final Work

### WARNING!

Reassemble the disassembled components in reverse order.

Check all hoses, hose, spring and Caillau clamps, as well as all electrical connections for firm seating. Secure all loose cables using cable ties.

Spray the heater unit components with anti-corrosion wax (Tectyl 100K, Order No. 111329).

- Connect the battery
- Set the digital timer.
- Check the proper operation of the air heater, see the operating instructions/installation instructions.
- Attach the "Switch off additional heater before refueling" sticker to the left-hand B-pillar.



# Webasto

*Feel the drive*

Webasto AG  
Postfach 80 - 82132 Stockdorf, Germany - Hotline +49-  
(0)1805-932278  
Hotfax +49-(0)395-5592-353 - <http://www.webasto.de>

**Operating Instructions for End Customer**

Please remove page and add to the vehicle operating instructions.



Only for vehicles with standard heater control and Telestart!

On vehicles with additional heater or auxiliary heater from factory, the fuel level may not be below 1/4 of a tank for proper operation of the *Air Top 2000 ST* air heater!

Before parking the vehicle, make the following settings:

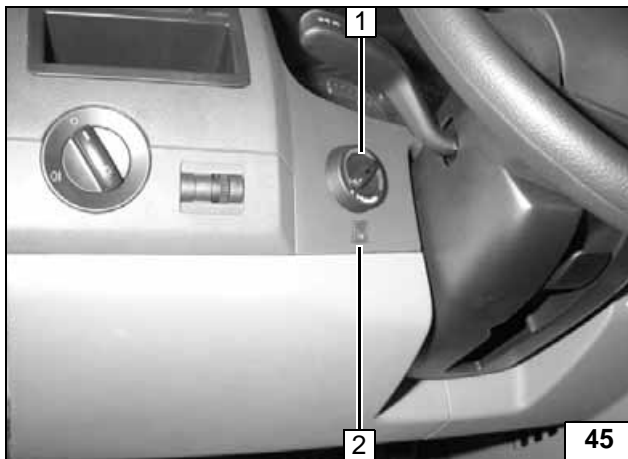

1. Switch S9 2 set to "Open"
2. Temperature on standard heater control 1 set to "warm" (start-up after switch-on on hand-held transmitter)

**Version A:  
Switching  
on heater  
with Tele-  
start**

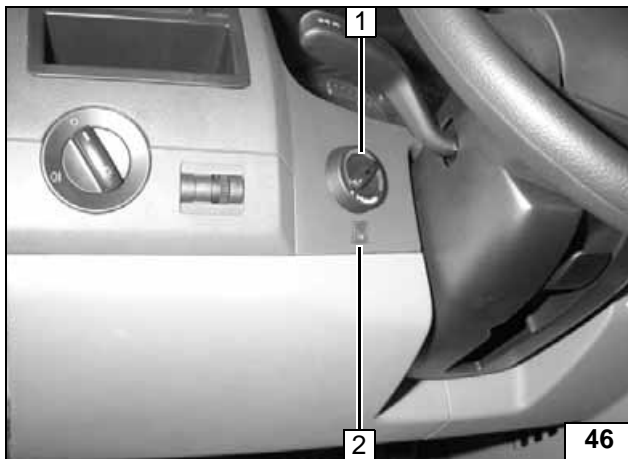

1. Switch S9 2 set to "Close"
2. Temperature on standard heater control 1 set to "warm" (immediate start-up)

**Version B:  
Switching  
on heater  
with heat-  
er control**

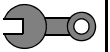

## Template for Fuel sender

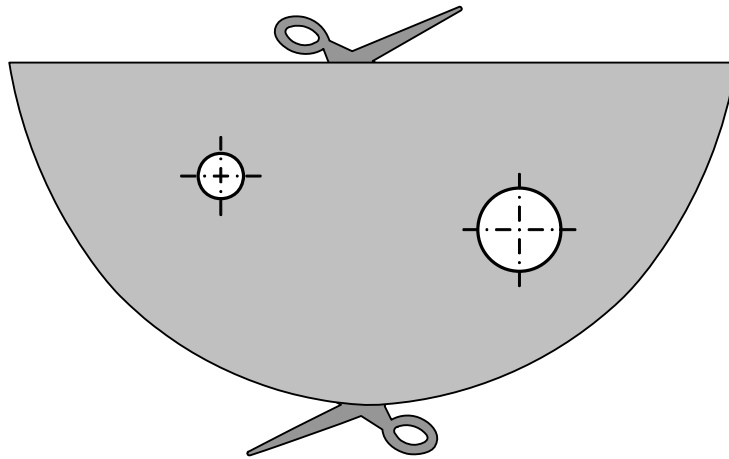

100 mm



Scale 1:1

Compare the size of the printed version with dimension lines.  
Permitted tolerance a maximum of 2%.

Correct major differences in the printer settings or request an original printout.

100 mm

0

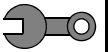

## Template for Fuel Standpipe



Scale 1:1

Compare the size of the printed version with dimension lines.  
Permitted tolerance a maximum of 2%.

Correct major differences in the printer settings or request an  
original printout.

0

100 mm