

## ORDERING REPLACEMENT PARTS

If you encounter any difficulties with this product, or if you need to order replacement parts, call the ICON Health & Fitness, Ltd. office, or write:

ICON Health & Fitness, Ltd.  
Customer Service Department  
Unit 4, Revie Road Industrial Estate  
Beeston  
Leeds, LS11 8JG  
UK

Tel:

**08457 089 009**

Outside the UK: 0 (044) 113 387 7133  
Fax: 0 (044) 113 387 7125

When ordering parts, please be prepared to give the following information:

- the MODEL NUMBER of the product (PFEVEX19010)
- the NAME of the product (PROFORM® 980 S EKG exercise cycle)
- the SERIAL NUMBER of the product (see the front cover of this manual)
- the KEY NUMBER and DESCRIPTION of the part(s) (see the PART LIST and the EXPLODED DRAWING on pages 22 and 23).

# PRO-FORM

## 980 S EKG

Class HC Fitness Product

Model No. PFEVEX19010  
Serial No. \_\_\_\_\_

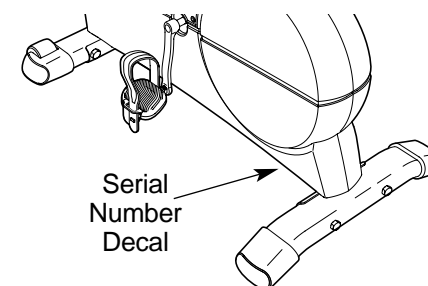

### QUESTIONS?

As a manufacturer, we are committed to providing complete customer satisfaction. If you have questions, or if there are missing or damaged parts, please call:

**08457 089 009**

Or write:  
ICON Health & Fitness, Ltd.  
Customer Service Department  
Unit 4  
Revie Road Industrial Estate  
Beeston  
Leeds, LS11 8JG  
UK

email: [csuk@iconeurope.com](mailto:csuk@iconeurope.com)

### ⚠ CAUTION

Read all precautions and instructions in this manual before using this equipment. Keep this manual for future reference.

## USER'S MANUAL

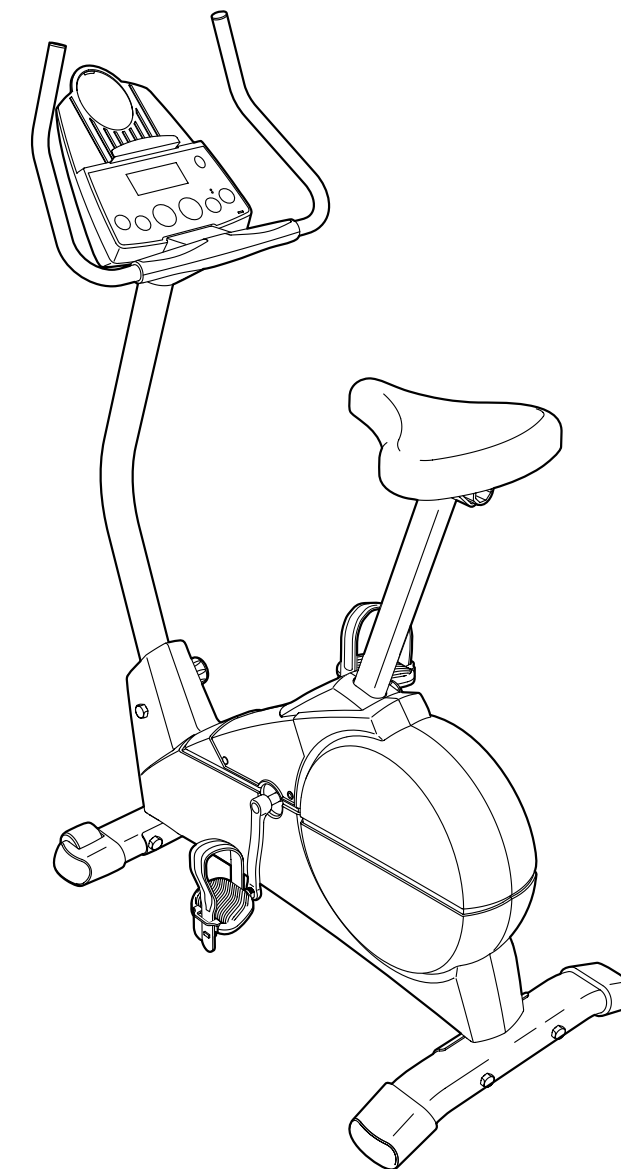

Visit our website at  
[www.proform.com](http://www.proform.com)

# PRO-FORM

## 980 S EKG

### TABLE OF CONTENTS

IMPORTANT PRECAUTIONS .....	3
BEFORE YOU BEGIN .....	4
ASSEMBLY .....	5
HOW TO OPERATE THE EXERCISE CYCLE .....	9
MAINTENANCE AND TROUBLE-SHOOTING .....	19
CONDITIONING GUIDELINES .....	20
PART LIST .....	22
EXPLODED DRAWING .....	23
ORDERING REPLACEMENT PARTS .....	Back Cover

### EXPLODED DRAWING—Model No. PFEVEX19010

R0202A

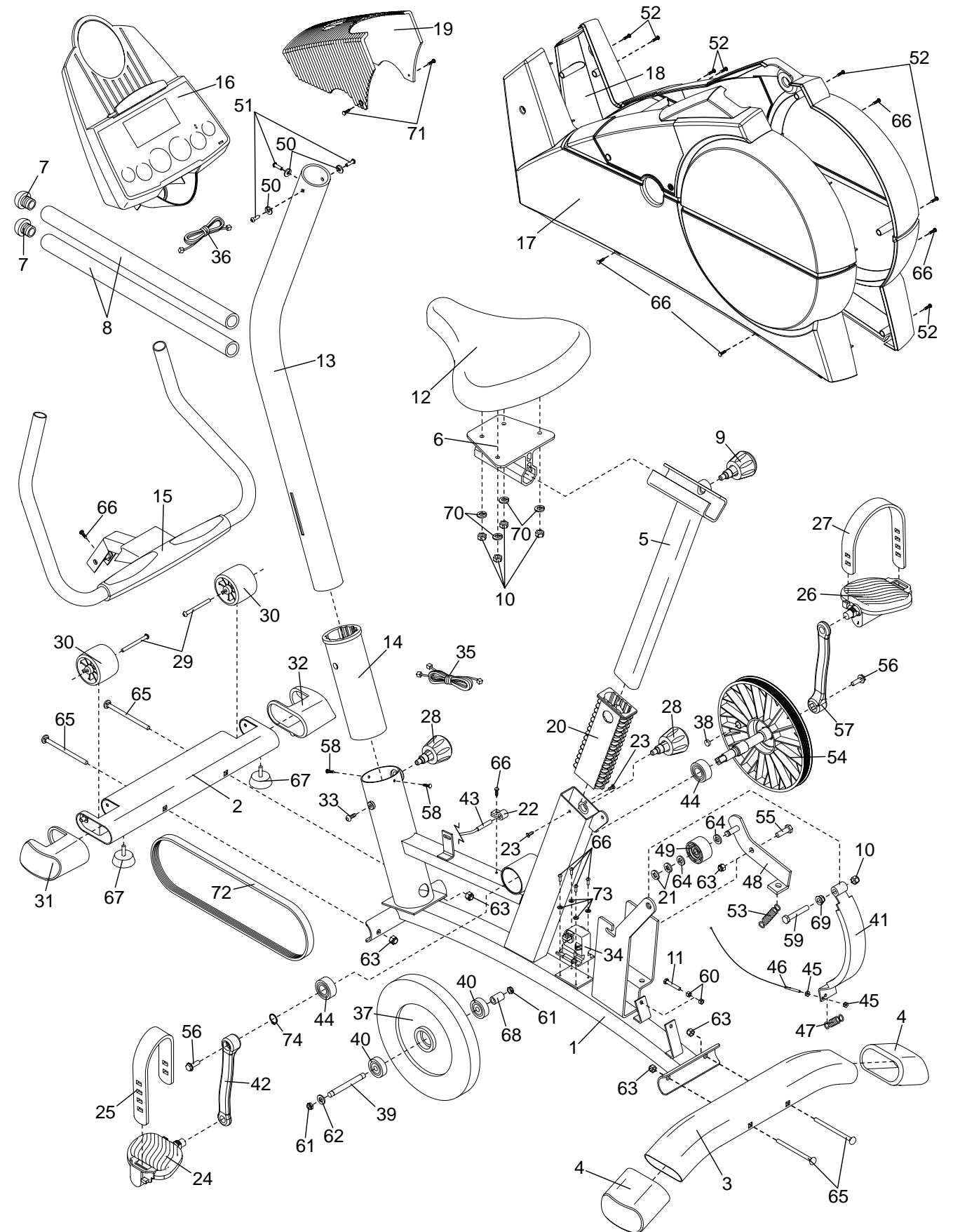

# EXPLODED DRAWING—Model No. PFEVEX19010

R0202A

Key No.	Qty.	Description	Key No.	Qty.	Description
1	1	Frame	41	1	“C” Magnet
2	1	Front Stabiliser	42	1	Left Crank Arm
3	1	Rear Stabiliser	43	1	Reed Switch/Wire
4	2	Rear Endcap	44	2	Crank Bearing
5	1	Seat Post	45	2	M5 Nut
6	1	Seat Bracket	46	1	Adjustment Cable
7	2	Handlebar Endcap	47	1	Return Spring
8	2	Foam Grip	48	1	Idler Arm
9	1	Seat Adjustment Knob	49	1	Idler Wheel w/Bearing
10	5	M8 Nylon Locknut	50	3	M10 Black Split Washer
11	1	M6 x 38mm Screw	51	3	M10 x 27mm Button Screw
12	1	Seat	52	7	M4 x 25mm Screw
13	1	Upright	53	1	Idler Arm Spring
14	1	Upright Bushing	54	1	Pulley
15	1	Handgrip Pulse Sensor/Handlebar	55	1	M10 x 25mm Flat Bolt
16	1	Console	56	2	Flange Screw
17	1	Left Side Shield	57	1	Right Crank Arm
18	1	Right Side Shield	58	2	M4 x 7mm Screw
19	1	Side Shield Cover	59	1	M8 x 47mm Button Bolt
20	1	Seat Upright Bushing	60	2	M6 Nut
21	2	M8 Push Nut	61	2	M8 Nylon Jam Nut
22	1	Reed Switch Clamp	62	1	Flywheel Washer
23	2	M4 x 5mm Screw	63	5	M10 Black Nylon Locknut
24	1	Left Pedal	64	2	Idler Washer
25	1	Left Pedal Strap	65	4	M10 x 112mm Carriage Bolt
26	1	Right Pedal	66	11	M4 x 16mm Screw
27	1	Right Pedal Strap	67	2	Leveling Foot
28	2	Adjustment Knob	68	1	Flywheel Spacer
29	2	M6 x 72mm Button Screw	69	1	M8 Flange Nut
30	2	Wheel	70	4	M8 Split Washer
31	1	Left Front Endcap	71	2	M4 x 12mm Round Head Screw
32	1	Right Front Endcap	72	1	Belt
33	1	M6 x 25.4mm Button Screw	73	4	Motor Washer
34	1	Adjustment Motor	74	1	Crank Axle Snap Ring
35	1	Lower Wire Harness	#	1	User’s Manual
36	1	Upper Wire Harness	#	1	Allen Wrench
37	1	Flywheel	#	1	Audio Cable
38	1	Magnet	#	1	Adapter
39	1	Flywheel Axle	#	1	Splitter
40	2	Flywheel Bearing			

Note: “#” indicates a non-illustrated part. Specifications are subject to change without notice. See the back cover of this manual for information about ordering replacement parts.

## IMPORTANT PRECAUTIONS

**⚠ WARNING:** To reduce the risk of serious injury, read the following important precautions before using the exercise cycle.

1. Read all instructions in this manual before using the exercise cycle.
2. It is the responsibility of the owner to ensure that all users of the exercise cycle are adequately informed of all precautions. Use the exercise cycle only as described in this manual.
3. Use the exercise cycle indoors on a level surface. Keep the exercise cycle away from moisture and dust. Place a mat under the exercise cycle to protect the floor.
4. Inspect and properly tighten all parts regularly. Replace any worn parts immediately.
5. Keep children under the age of 12 and pets away from the exercise cycle at all times.
6. Wear appropriate clothing when exercising; do not wear loose clothing that could become caught on the exercise cycle. Always wear athletic shoes for foot protection.
7. The exercise cycle should not be used by persons weighing more than 114 kg (250 lbs.).
8. Always keep your back straight when using the exercise cycle; do not arch your back.
9. If you feel pain or dizziness whilst exercising, stop immediately and cool down.
10. The exercise cycle does not have a freewheel; the pedals will continue to move until the flywheel stops.
11. The pulse sensor is not a medical device. Various factors, including the user's movement, may affect the accuracy of heart rate readings. The pulse sensor is intended only as an exercise aid in determining heart rate trends in general.
12. The exercise cycle is intended for home use only. Do not use the exercise cycle in a commercial, rental, or institutional setting.

**⚠ WARNING:** Before beginning this or any exercise program, consult your physician. This is especially important for persons over the age of 35 or persons with pre-existing health problems. Read all instructions before using. ICON assumes no responsibility for personal injury or property damage sustained by or through the use of this product.

## BEFORE YOU BEGIN

Congratulations for selecting the new PROFORM® 980 S EKG exercise cycle. Cycling is one of the most effective exercises for increasing cardiovascular fitness, building endurance, and toning the entire body. The PROFORM® 980 S EKG offers an impressive array of features to let you enjoy this healthful exercise in the convenience and privacy of your home.

**For your benefit, read this manual carefully before you use the exercise cycle.** If you have questions

after reading the manual, please call our Customer Service Department at **08457 089 009**. To help us assist you, please note the product model number and serial number before calling. The model number is PFEVEX19010. The serial number can be found on a decal attached to the exercise cycle (see the front cover of this manual).

Before reading further, please familiarise yourself with the parts that are labeled in the drawing below.

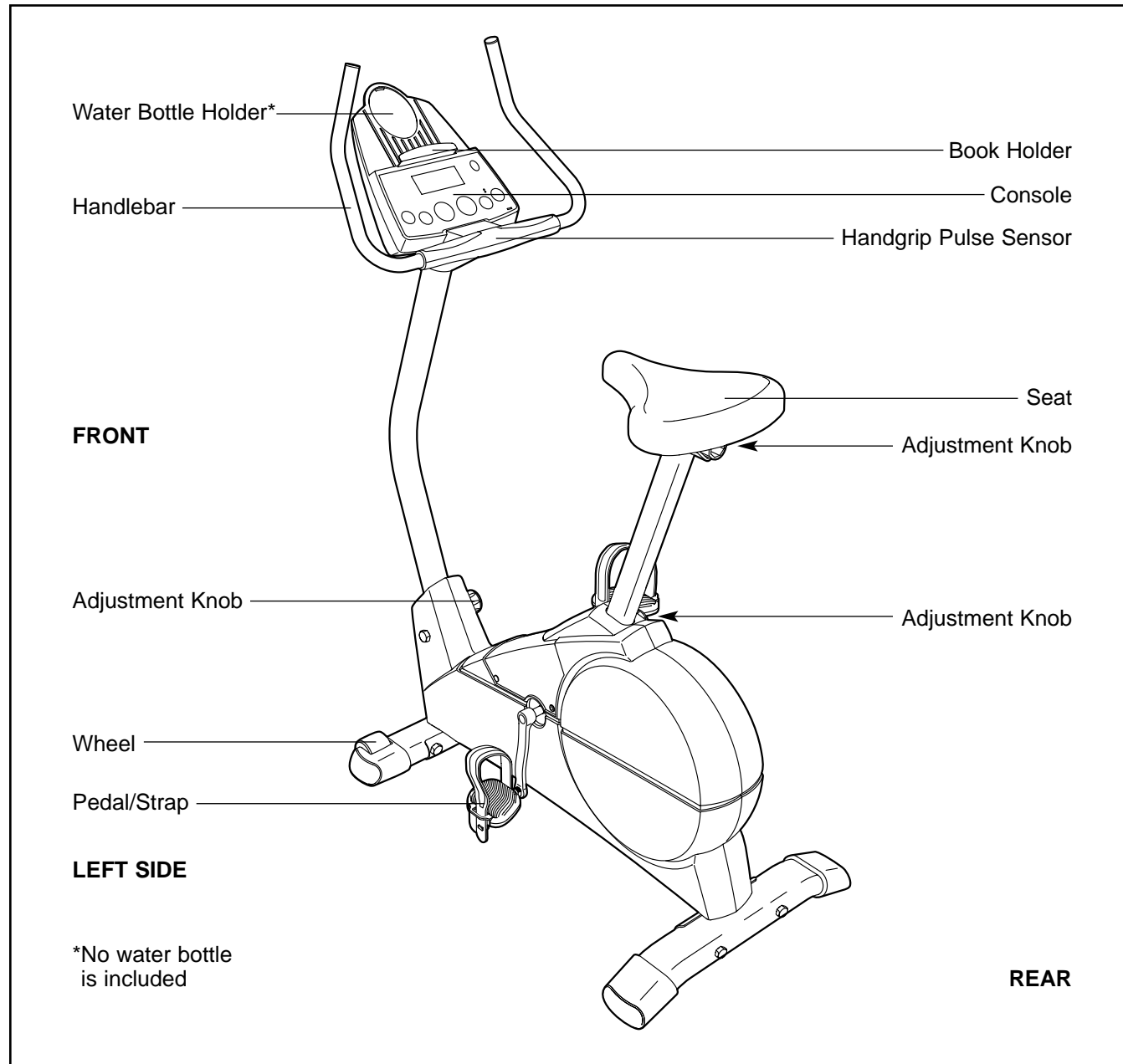

## SUGGESTED STRETCHES

The correct form for several basic stretches is shown at the right. Move slowly as you stretch—never bounce.

### 1. Toe Touch Stretch

Stand with your knees bent slightly and slowly bend forward from your hips. Allow your back and shoulders to relax as you reach down toward your toes as far as possible. Hold for 15 counts, then relax. Repeat 3 times. Stretches: Hamstrings, back of knees and back.

### 2. Hamstring Stretch

Sit with one leg extended. Bring the sole of the opposite foot toward you and rest it against the inner thigh of your extended leg. Reach toward your toes as far as possible. Hold for 15 counts, then relax. Repeat 3 times for each leg. Stretches: Hamstrings, lower back and groin.

### 3. Calf/Achilles Stretch

With one leg in front of the other, reach forward and place your hands against a wall. Keep your back leg straight and your back foot flat on the floor. Bend your front leg, lean forward and move your hips toward the wall. Hold for 15 counts, then relax. Repeat 3 times for each leg. To cause further stretching of the achilles tendons, bend your back leg as well. Stretches: Calves, achilles tendons and ankles.

### 4. Quadriceps Stretch

With one hand against a wall for balance, reach back and grasp one foot with your other hand. Bring your heel as close to your buttocks as possible. Hold for 15 counts, then relax. Repeat 3 times for each leg. Stretches: Quadriceps and hip muscles.

### 5. Inner Thigh Stretch

Sit with the soles of your feet together and your knees outward. Pull your feet toward your groin area as far as possible. Hold for 15 counts, then relax. Repeat 3 times. Stretches: Quadriceps and hip muscles.

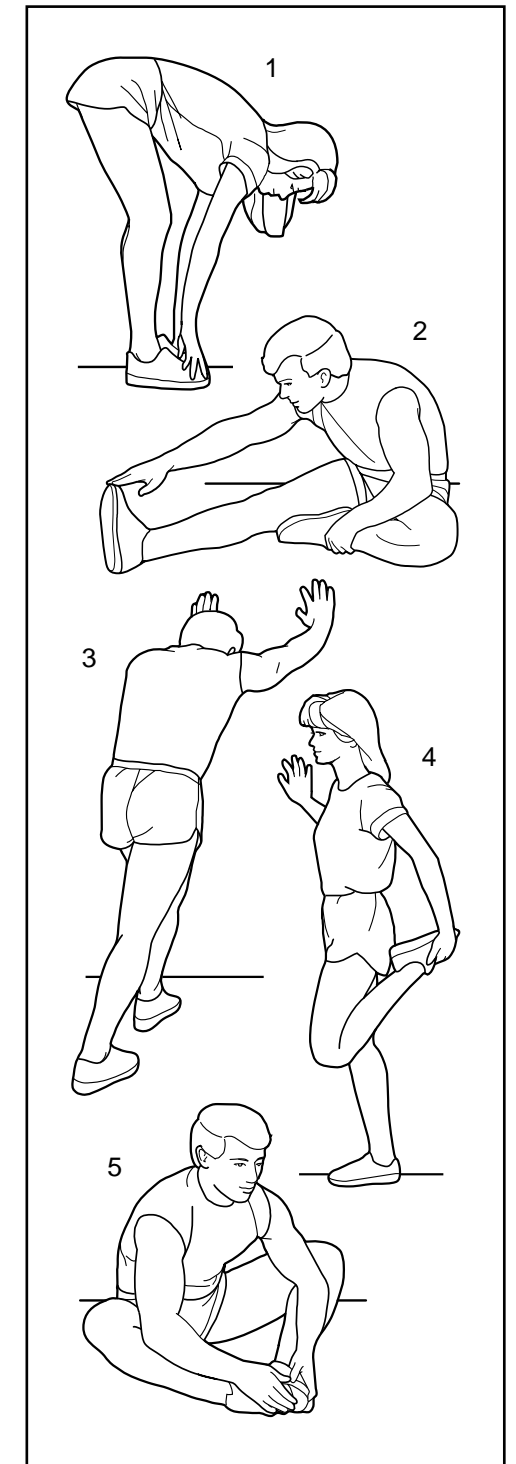

## CONDITIONING GUIDELINES

The following guidelines will help you to plan your exercise program. Remember that proper nutrition and adequate rest are essential for successful results.

**⚠ WARNING:** Before beginning this or any exercise program, consult your physician. This is especially important for persons over the age of 35 or persons with pre-existing health problems.

The pulse sensor is not a medical device. Various factors may affect the accuracy of heart rate readings. The pulse sensor is intended only as an exercise aid in determining heart rate trends in general.

### EXERCISE INTENSITY

Whether your goal is to burn fat or to strengthen your cardiovascular system, the key to achieving the desired results is to exercise with the proper intensity. The proper intensity level can be found by using your heart rate as a guide. The chart below shows recommended heart rates for fat burning, maximum fat burning, and cardiovascular (aerobic) exercise.

165	155	145	140	130	125	115	♥
145	138	130	125	118	110	103	♥
125	120	115	110	105	95	90	♥
20	30	40	50	60	70	80	

To find the proper heart rate for you, first find your age at the bottom line of the chart (ages are rounded off to the nearest ten years). Next, find the three numbers above your age. The three numbers are your "training zone." The lowest number is the recommended heart rate for fat burning; the middle number is the recommended heart rate for maximum fat burning; the highest number is the recommended heart rate for aerobic exercise.

### Fat Burning

To burn fat effectively, you must exercise at a relatively low intensity level for a sustained period of time.

During the first few minutes of exercise, your body uses easily accessible carbohydrate calories for energy. Only after the first few minutes of exercise does your body begin to use stored fat calories for energy. If your goal is to burn fat, adjust the intensity of your exercise until your heart rate is near the lowest number in your training zone as you exercise. For maximum fat burning, adjust the intensity of your exercise until your heart rate is near the middle number in your training zone as you exercise.

### Aerobic Exercise

If your goal is to strengthen your cardiovascular system, your exercise must be "aerobic." Aerobic exercise is activity that requires large amounts of oxygen for prolonged periods of time. This increases the demand on the heart to pump blood to the muscles, and on the lungs to oxygenate the blood. For aerobic exercise, adjust the intensity of your exercise until your heart rate is near the highest number in your training zone.

### WORKOUT GUIDELINES

Each workout should include the following three parts:

**A warm-up**, consisting of 5 to 10 minutes of stretching and light exercise. A proper warm-up increases your body temperature, heart rate, and circulation in preparation for exercise.

**Training zone exercise**, consisting of 20 to 30 minutes of exercising with your heart rate in your training zone. (During the first few weeks of your exercise program, do not keep your heart rate in your training zone for longer than 20 minutes.)

**A cool-down**, with 5 to 10 minutes of stretching. This will increase the flexibility of your muscles and will help to prevent post-exercise problems.

### EXERCISE FREQUENCY

To maintain or improve your condition, plan three workouts each week, with at least one day of rest between workouts. After a few months of regular exercise, you may complete up to five workouts each week, if desired. Remember, the key to success is make exercise a regular and enjoyable part of your everyday life.

## ASSEMBLY

**Assembly requires two persons.** Place all parts of the exercise cycle in a cleared area and remove the packing materials. Do not dispose of the packing materials until assembly is completed.

**Assembly requires the included tools and your own adjustable spanner**  **and Phillips screwdriver** .

Use the part drawings below to identify the small parts used in assembly. The number in parenthesis below each drawing refers to the key number of the part, from the PART LIST on page 22. The second number refers to the quantity needed for assembly. **Note: Some small parts may have been pre-attached for shipping. If a part is not in the parts bag, check to see if it has been pre-attached.**

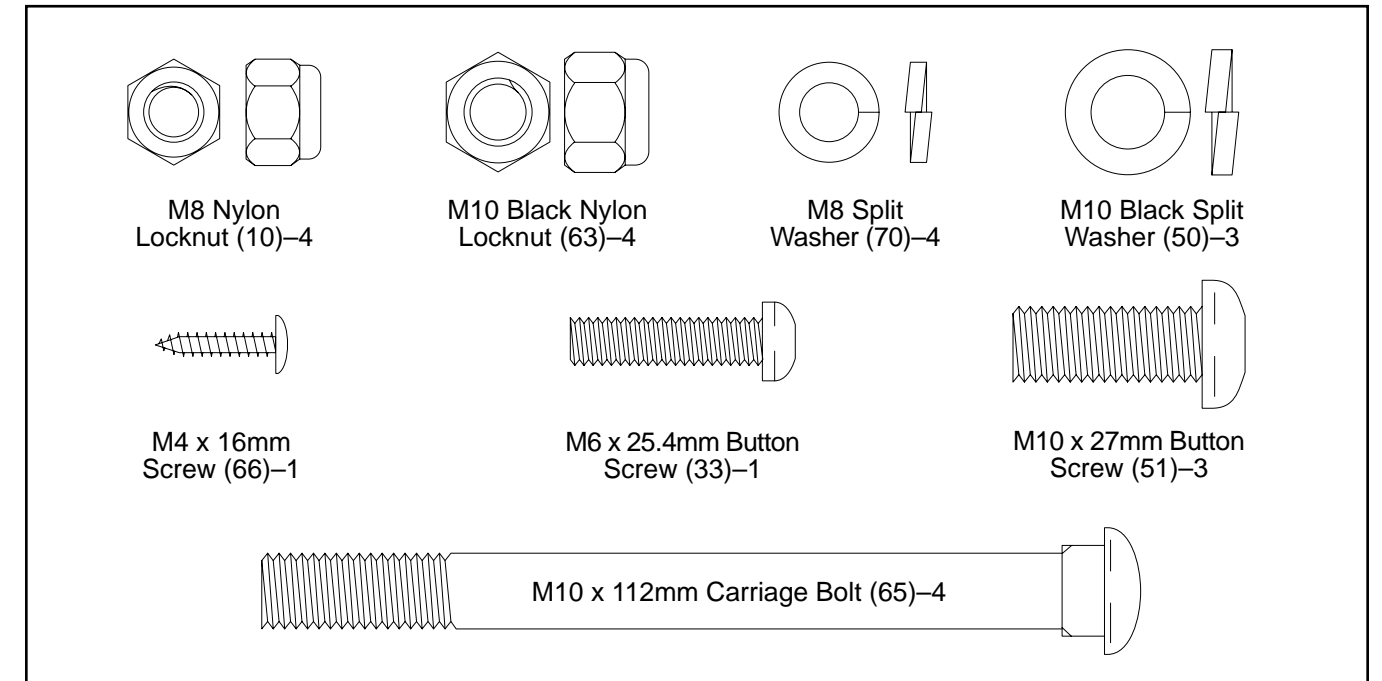

1. Identify the Front Stabiliser (2), which has Wheels (30) on the ends. Whilst another person lifts the front of the Frame (1) slightly, attach the Front Stabiliser to the Frame with two M10 x 112mm Carriage Bolts (65) and two M10 Black Nylon Locknuts (63). **Make sure that the Front Stabiliser is turned so the Wheels are not touching the floor.**

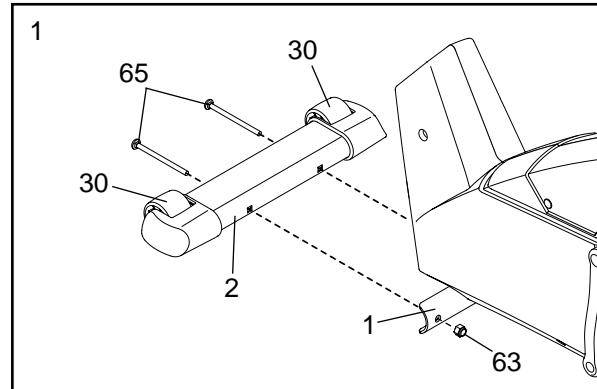

2. Whilst another person lifts the back of the Frame (1) slightly, attach the Rear Stabiliser (3) to the Frame with two M10 x 112mm Carriage Bolts (65) and two M10 Black Nylon Locknuts (63).

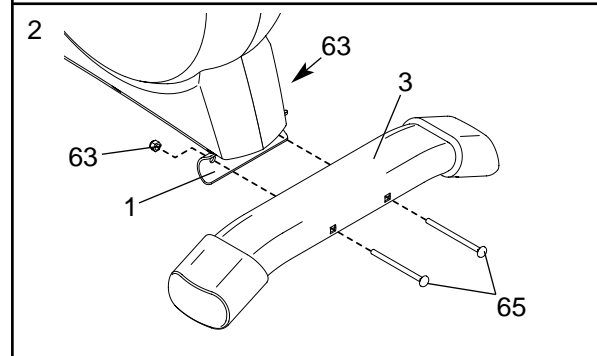

3. Whilst another person holds the Upright (13) in the position shown, connect the Upper Wire Harness (36) to the Lower Wire Harness (35). **Carefully pull the upper end of the Upper Wire Harness to remove any slack from the Wire Harnesses; make sure the connectors do not catch on the indicated rod.**

Turn the indicated Adjustment Knob (28) counterclockwise two or three turns to loosen it. Next, pull the Knob, insert the Upright (13) into the Frame (1), and then release the Knob. **Be careful to avoid pinching the Wire Harnesses (35, 36). Move the Upright up and down slightly until the pin on the Knob snaps into one of the holes in the Upright.** Then, turn the Knob clockwise until it is tight.

Tighten the M6 x 25.4mm Button Screw (33) into the Frame (1) and into the slot in the side of the Upright (13).

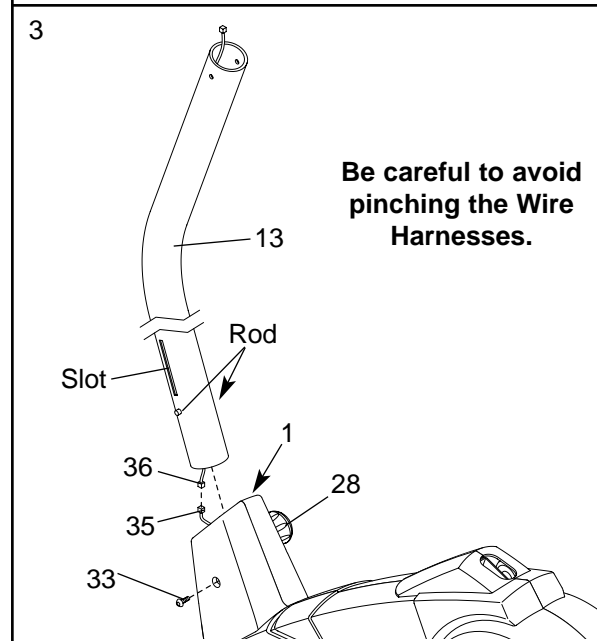

4. The Console (16) requires four 1.5 v ("D") batteries (not included); alkaline batteries are recommended. Press the tab on the battery cover, and lift off the battery cover. Insert four batteries into the battery compartment. **Make sure that the batteries are oriented as shown by the diagram inside the battery compartment.** Reattach the battery cover.

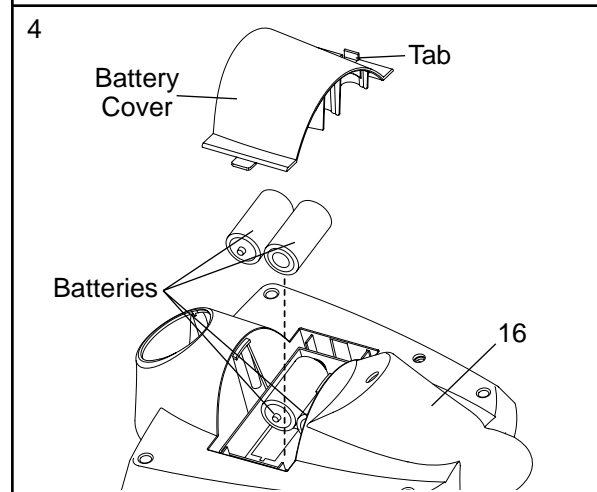

## MAINTENANCE AND TROUBLESHOOTING

Inspect and tighten all parts of the exercise cycle regularly. Replace any worn parts immediately.

To clean the exercise cycle, use a damp cloth and a small amount of mild soap. **Important: To avoid damage to the console, keep liquids away from the console and keep the console out of direct sunlight.**

### BATTERY REPLACEMENT

If the console display becomes dim, the batteries should be replaced; most console problems are the result of low batteries. Refer to assembly step 4 on page 6 for replacement instructions. Note: The console requires four 1.5 V ("D") batteries.

### HOW TO LEVEL THE EXERCISE CYCLE

After the exercise cycle has been moved to the location where it will be used, make sure that both ends of front stabiliser are touching the floor. If the exercise cycle rocks slightly during use, turn one or both of the leveling feet under the front stabiliser until the rocking motion is eliminated.

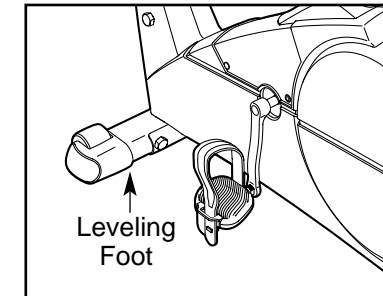

### HANDGRIP PULSE SENSOR TROUBLE-SHOOTING

- Avoid moving your hands whilst using the handgrip pulse sensor. Excessive movement may interfere with heart rate readings.
- Do not hold the metal contacts too tightly; doing so may interfere with heart rate readings.

- For the most accurate heart rate reading, hold the metal contacts for about 15 seconds.
- For optimal performance of the handgrip pulse sensor, keep the metal contacts clean. The contacts can be cleaned with a soft cloth—never use alcohol, abrasives, or chemicals.

### HOW TO MOVE THE EXERCISE CYCLE

To move the exercise cycle, first stand in front of the exercise cycle, hold the handlebars, and place one foot on the front stabiliser. Pull the handlebars until the exercise cycle can be moved on the front wheels. Carefully move the exercise cycle to the desired location and then lower it.

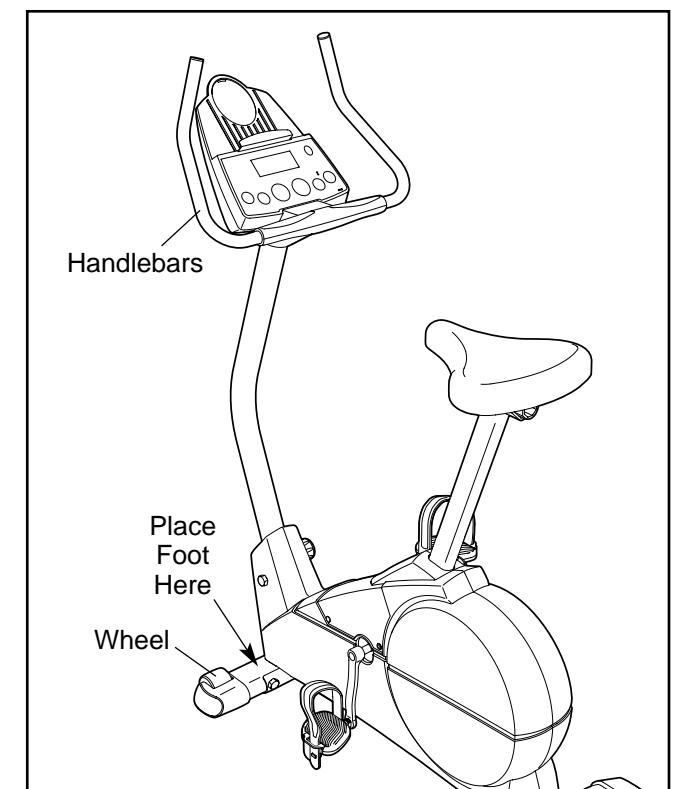

## HOW TO USE PROGRAMS DIRECTLY FROM OUR WEB SITE

Our Web site at [www.iFIT.com](http://www.iFIT.com) allows you to play iFIT.com audio and video programs directly from the internet. To use programs from our Web site, the exercise cycle must be connected to your home computer. See HOW TO CONNECT YOUR COMPUTER on page 15. In addition, you must have an internet connection and an internet service provider. A list of specific system requirements will be found on our Web site.

Follow the steps below to use a program from our Web site.

### 1 Turn on the console.

Refer to step 1 on page 12.

### 2 Select the iFIT.com mode.

Each time the console is turned on, the manual mode will be selected. To select the iFIT.com mode, press the iFIT.com button, press the iFIT.com button. The indicator on the button will light and the letters IF will appear in the upper right corner of the display.

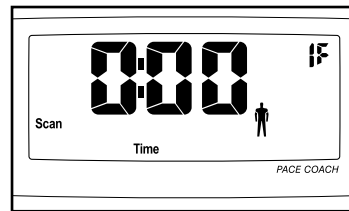

### 3 Go to your computer and start an internet connection.

### 4 Start your Web browser, if necessary, and go to our Web site at [www.iFIT.com](http://www.iFIT.com).

### 5 Follow the desired links on our Web site to select a program.

Read and follow the on-line instructions for using a program.

### 6 Follow the on-line instructions to start the program.

When you start the program, an on-screen count-down will begin.

### 7 Return to the exercise cycle and begin exercising.

When the on-screen countdown ends, the program will begin. The program will function in almost the same way as a Smart program (refer to step 3 on page 13). However, an electronic "chirping" sound will alert you when the resistance and/or the target pace is about to change.

### 8 Follow your progress with the feedback modes.

Refer to step 4 on page 12.

### 9 Measure your heart rate if desired.

Refer to step 5 on page 12.

### 10 When you are finished exercising, the console will automatically turn off after a few minutes.

Refer to step 6 on page 12.

## THE OPTIONAL CHEST PULSE SENSOR

The optional chest pulse sensor provides hands-free operation and continuously monitors your heart rate during your workouts. **To purchase the optional chest pulse sensor, call 08457 089 009.**

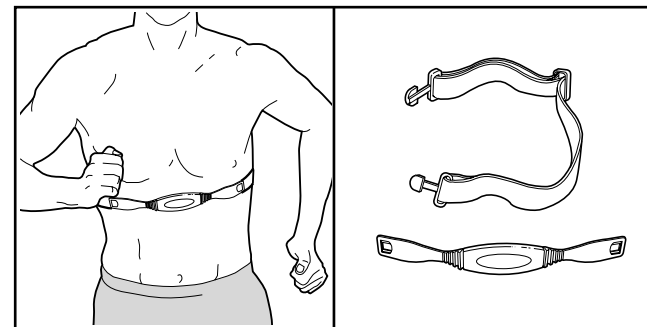

- Connect the wire harness on the Handgrip Pulse Sensor (15) to the indicated wire harness on the Console (16). Insert both wire harnesses into the opening in the bottom of the Console. Then, insert the metal tube on the Handgrip Pulse Sensor into the opening in the bottom of the console. **Be careful not to pinch the Wire Harnesses.**

Refer to the inset drawing. Tighten an M4 x 16mm Screw (66) into the indicated bracket on the Console (16) and into the metal tube on the Handgrip Pulse Sensor (15).

Snap the bookrack onto the Console (16) where shown.

- Whilst another person holds the Console (16) in the position shown, connect the wire harness on the Console to the Upper Wire Harness (36). Insert the excess wire harness into the Upright (13).

Attach the Console (16) to the Upright (13) with three M10 x 27mm Button Screws (51) and three M10 Black Split Washers (50). **Be careful to avoid pinching the Wire Harnesses.**

- Turn the indicated Adjustment Knob (28) counterclockwise two or three turns to loosen it. Next, pull the Knob, insert the Seat Post (5) into the Frame (1), and then release the Knob. **Move the Seat Post up and down slightly until the pin on the Knob snaps into one of the holes in the Seat Post.** Then, turn the Knob clockwise until it is tight.

- Attach the Seat (12) to the Seat Bracket (6) with four M8 Nylon Locknuts (10) and four M8 Split Washers (70). Note: The Nylon Locknuts and the Split Washers may be pre-attached to the underside of the Seat.

Turn the Seat Adjustment Knob (9) counterclockwise two or three turns to loosen it. Next, pull the Knob, slide the Seat Bracket (6) into the top of the Seat Post (5), and then release the Knob. **Move the Seat Bracket forward and backward slightly until the pin on the Knob snaps into one of the holes in the Seat Bracket.** Then, turn the Knob clockwise until it is tight.

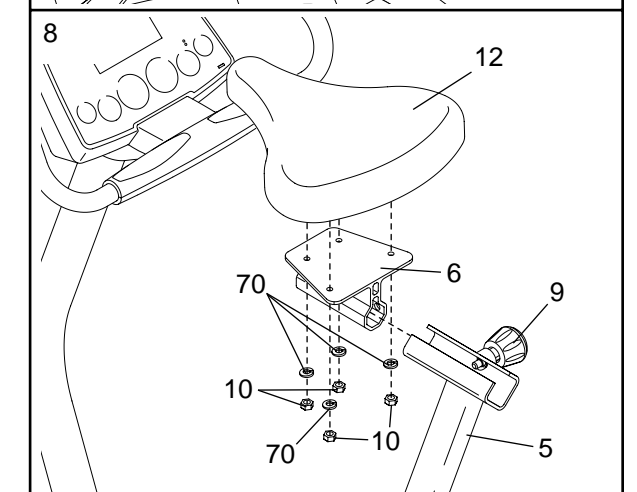
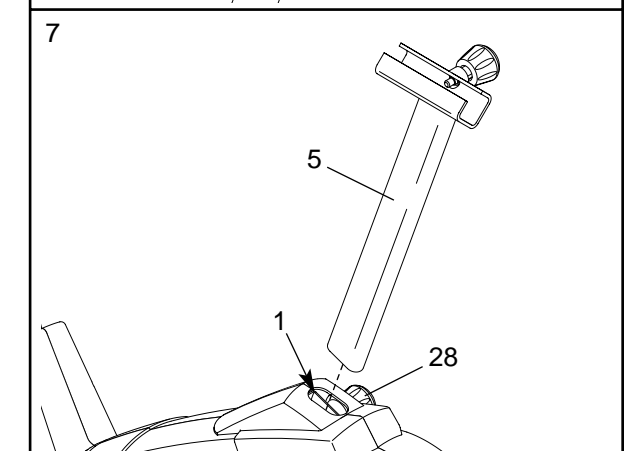
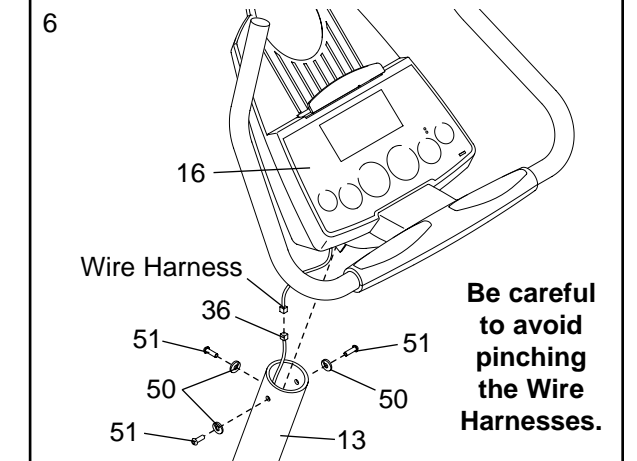
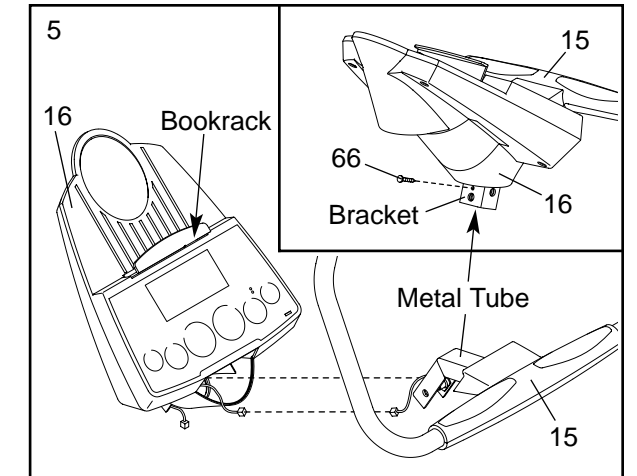

9. Identify the Left Pedal (24), which is marked with an "L." Using an adjustable spanner, **firmly tighten** the Left Pedal counterclockwise into the Left Crank Arm (42). Tighten the Right Pedal (not shown) clockwise into the Right Crank Arm. **Important: Tighten both Pedals as firmly as possible. After using the exercise cycle for one week, retighten the Pedals. For best performance, the Pedals must be kept tightened.**

Adjust the Left Pedal Strap (25) to the desired position, and press the end of the Pedal Strap onto the tab on the Left Pedal (24). Adjust the Right Pedal Strap (not shown) in the same way.

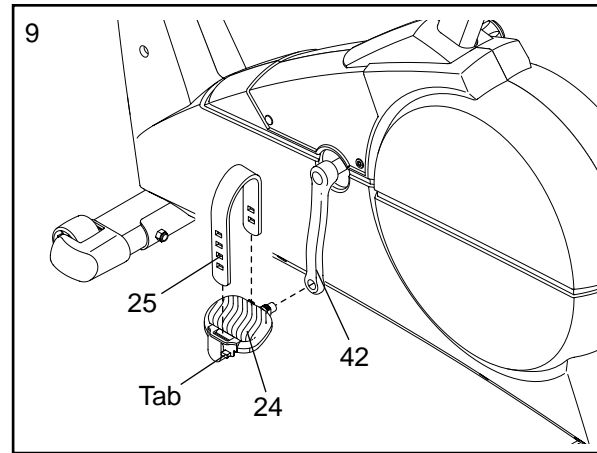

10. **Make sure that all parts are properly tightened before you use the exercise cycle.** Note: After assembly is completed, some extra parts may be left over. Place a mat beneath the exercise cycle to protect the floor.

### INSTALLING THE RECEIVER FOR THE OPTIONAL CHEST PULSE SENSOR

If you purchase the optional chest pulse sensor (refer to page 18), follow the steps below to install the receiver and the jumper wire included with the chest pulse sensor.

1. Remove the four indicated screws from the back of the Console (16). Lift off the front of the Console.

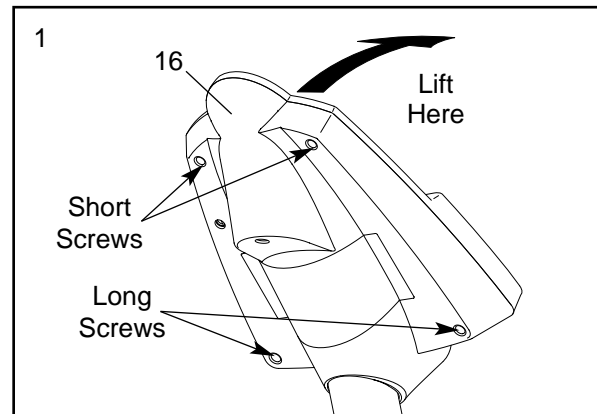

2. Plug the jumper wire (A) into the indicated jack on the Console (16). Connect the other end of the jumper wire to the wire on the receiver (B). **Note: Discard any other wires included with the chest pulse sensor.**

Next, peel the paper off the adhesive pad on the back of the receiver (B). Orient the receiver as shown, and press it onto the Console (16) in the indicated location.

Refer to step 1 above. Reattach the front of the Console (16) with the four screws. **Make sure that no wires are pinched.**

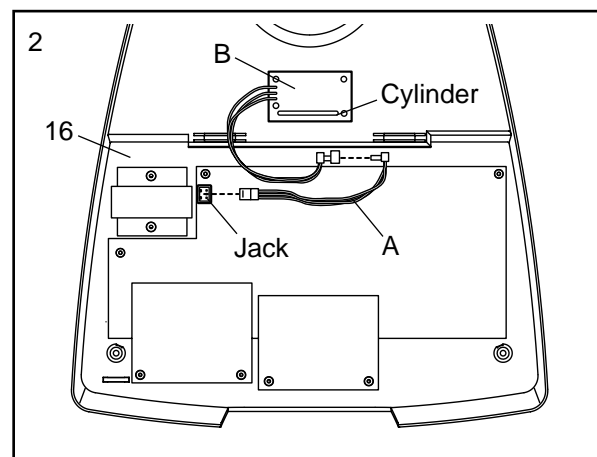

### HOW TO USE iFIT.COM CD AND VIDEO PROGRAMS

To use iFIT.com CDs or videocassettes, the exercise cycle must be connected to your portable CD player, portable stereo, home stereo, computer with CD player, or VCR. See HOW TO CONNECT YOUR CD PLAYER, VCR, OR COMPUTER on page 14. **Note: For information about the availability of iFIT.com CD's or videocassettes, send an e-mail to workouts@iFIT.com, and we'll notify you as soon as iFIT.com CD's and videocassettes are available.**

Follow the steps below to use an iFIT.com CD or video program.

- 1 Turn on the console.**

Refer to step 1 on page 12.

- 2 Select the iFIT.com mode.**

Each time the console is turned on, the manual mode will be selected. To select the iFIT.com mode, press the iFIT.com button. The indicator on the button will light and the letters IF will appear in the upper right corner of the display.

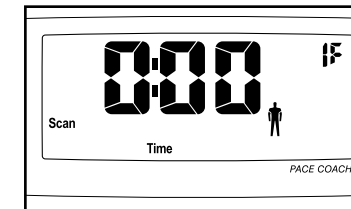

- 3 Insert the iFIT.com CD or videocassette.**

If you are using an iFIT.com CD, insert the CD into your CD player. If you are using an iFIT.com videocassette, insert the videocassette into your VCR.

- 4 Press the play button on your CD player or VCR.**

A moment after the play button is pressed, your personal trainer will begin guiding you through your workout. Simply follow your personal trainer's instructions.

The program will function in almost the same way as a Smart program (refer to step 3 on page 13). However, an electronic "chirping" sound will alert you when the resistance and/or the target pace is about to change.

**Note: If the resistance and/or the target pace does not change when a "chirp" is heard:**

- **Make sure that the indicator on the iFIT.com button is lit.**
- **Adjust the volume of your CD player or VCR. If the volume is too high or too low, the console may not detect the program signals.**
- **Make sure that the audio cable is properly connected and that it is fully plugged in.**

- 5 Follow your progress with the feedback modes.**

Refer to step 4 on page 12.

- 6 Measure your heart rate if desired.**

Refer to step 5 on page 12.

- 7 When you are finished exercising, the console will automatically turn off after a few minutes.**

Refer to step 6 on page 12.



## HOW TO CONNECT YOUR VCR

**Note: If your VCR has an unused AUDIO OUT jack, see instruction A below. If the AUDIO OUT jack is being used, see instruction B. If you have a TV with a built-in VCR, see instruction B. If your VCR is connected to your home stereo, see HOW TO CONNECT YOUR HOME STEREO on page 15.**

A. Plug one end of the audio cable into the jack beneath the console of the exercise cycle. Plug the other end of the cable into the included adapter. Plug the adapter into the AUDIO OUT jack on your VCR.

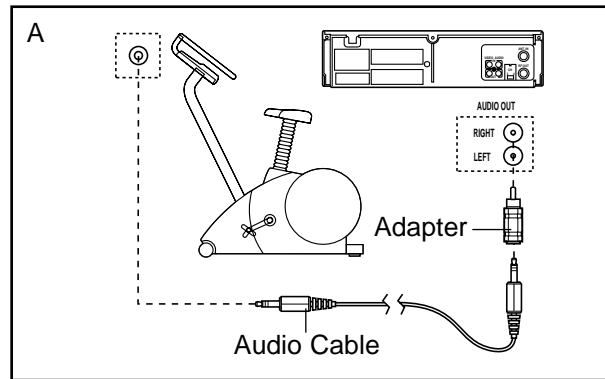

B. Plug one end of the audio cable into the jack beneath the console of the exercise cycle. Plug the other end of the cable into the included adapter. Plug the adapter into an RCA adapter (available at electronics stores). Next, remove the wire that is currently plugged into the AUDIO OUT jack on your VCR and plug the wire into the unused side of the RCA adapter. Plug the RCA adapter into the AUDIO OUT jack on your VCR.

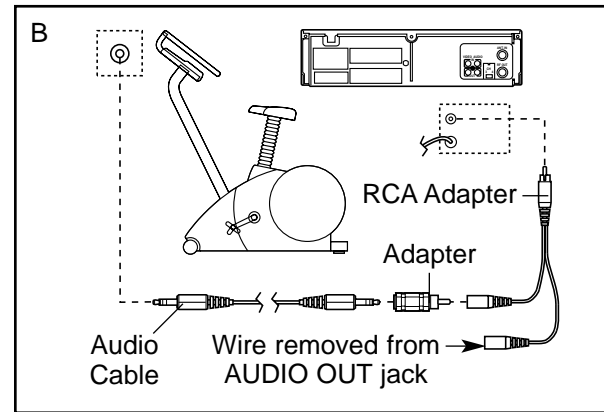

## HOW TO OPERATE THE EXERCISE CYCLE

### HOW TO ADJUST THE SEAT POST

For effective exercise, the seat should be at the proper height. As you pedal, there should be a slight bend in your knees when the pedals are in the lowest position. To adjust the height of the seat, first turn the indicated knob counterclockwise two or three turns to loosen it (if the knob is not loosened enough, it may scratch the seat post). Next, pull the knob, slide the seat post to the desired height, and then release the knob. **Move the seat post up and down slightly until the pin on the knob snaps into one of the holes in the seat post.** Then, turn the knob clockwise until it is tight.

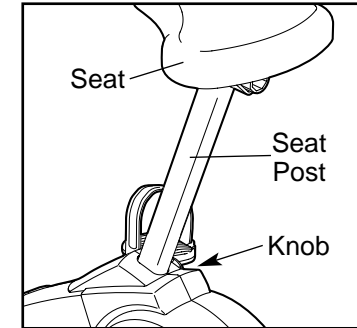

### HOW TO ADJUST THE SEAT

The seat can be adjusted to the position that is the most comfortable for you. To adjust the seat, first turn the indicated knob counterclockwise two or three turns to loosen it (if the knob is not loosened enough, it may scratch the seat bracket). Next, pull the knob, slide the seat to the desired position, and then release the knob. **Move the seat bracket forward and backward slightly until the pin on the knob snaps into one of the holes in the seat bracket.** Then, turn the knob clockwise until it is tight.

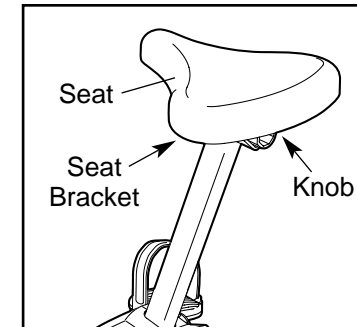

### HOW TO ADJUST THE UPRIGHT

The upright can be adjusted to the height that is the most comfortable for you. To adjust the upright, first turn the indicated knob counterclockwise two or three turns to loosen it (if the knob is not loosened enough, it may scratch the upright). Next, pull the knob, slide the upright to the desired height, and then release the knob. **Move the upright up and down slightly until the pin on the knob snaps into one of the holes in the upright.** Then, turn the knob clockwise until it is tight.

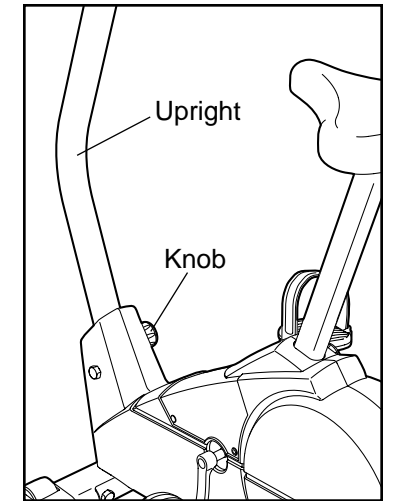

### HOW TO ADJUST THE PEDAL STRAPS

To adjust the pedal straps, first pull the ends of the straps off the tabs on the pedals. Adjust the straps to the desired position, and press the ends of the straps back onto the tabs.

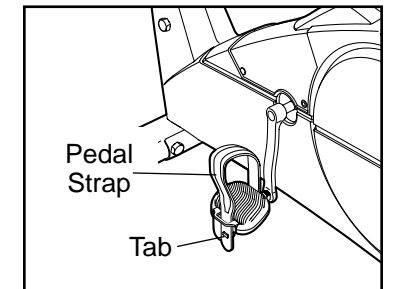

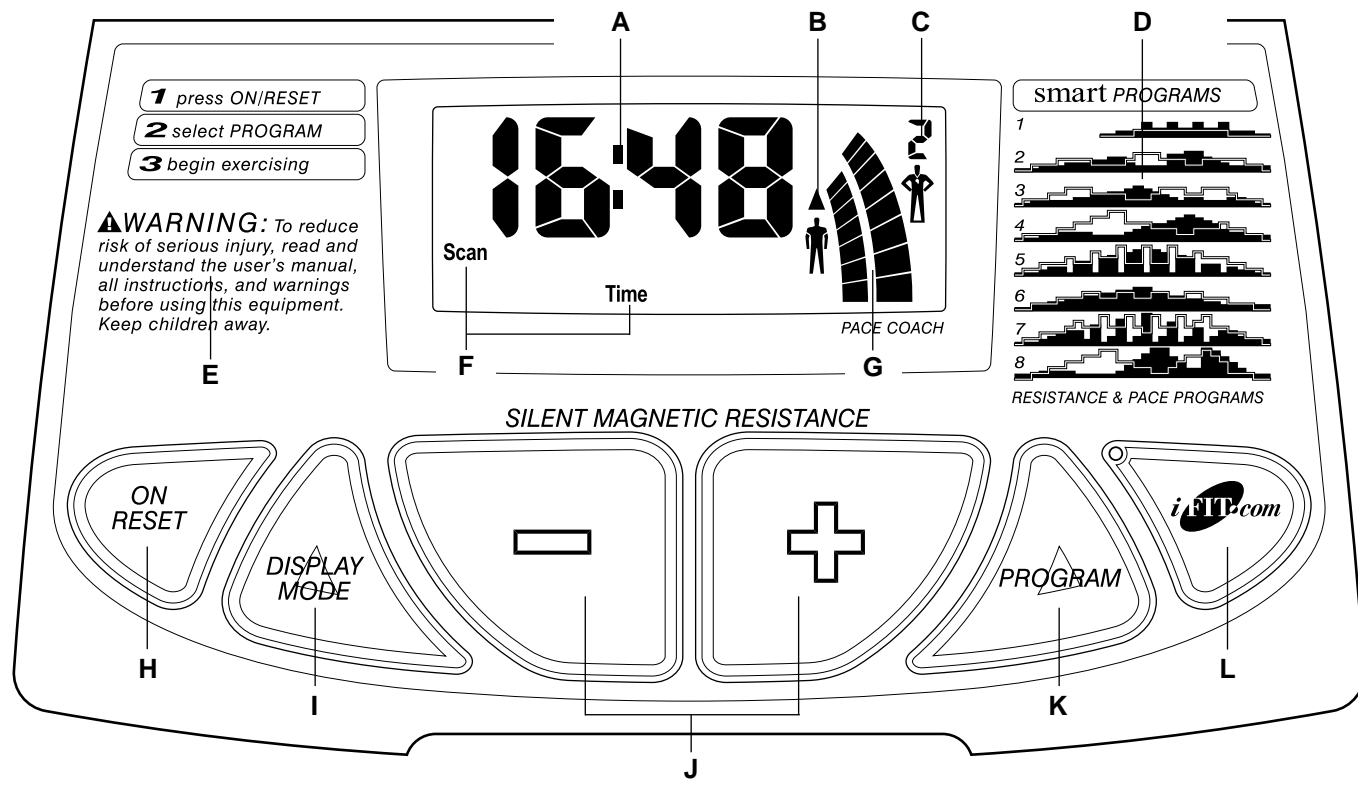

### FEATURES OF THE CONSOLE

The advanced console offers a selection of features designed to make your workouts more enjoyable and effective. When the manual mode of the console is selected, the resistance of the exercise cycle can be adjusted with a touch of a button. As you exercise, the console will provide continuous exercise feedback. You can even measure your heart rate using the built-in handgrip pulse sensor. (For information about an optional chest pulse sensor, refer to page 18.)

The console also offers eight Smart workout programs. Each program automatically changes the resistance of the exercise cycle and prompts you to increase or decrease your pace as it guides you through an effective workout.

The console also features new iFIT.com interactive technology. iFIT.com technology is like having a personal trainer right in your home. Using the included audio cable, you can connect the exercise cycle to your home stereo, portable stereo, or computer and play special iFIT.com CD programs. iFIT.com CD programs

automatically control the resistance of the exercise cycle and prompt you to vary your pace as a personal trainer coaches you through every step of your workout. High-energy music provides added motivation. Each CD features two programs designed by certified personal trainers.

In addition, you can connect the exercise cycle to your VCR and TV and play iFIT.com video programs (videocassettes are available separately). Video programs offer the same benefits as iFIT.com CD programs, but add the excitement of working out with a class and an instructor.

With the exercise cycle connected to your computer, you can also go to our new Web site at [www.iFIT.com](http://www.iFIT.com) and access audio programs and video programs directly from the internet.

**For information about the availability of iFIT.com CD's or videocassettes, send an e-mail to [workouts@iFIT.com](mailto:workouts@iFIT.com), and we'll notify you as soon as iFIT.com CD's and videocassettes are available.**

### HOW TO CONNECT YOUR HOME STEREO

**Note: If your stereo has an unused LINE OUT jack, see instruction A below. If the LINE OUT jack is being used, see instruction B.**

- A. Plug one end of the audio cable into the jack beneath the console of the exercise cycle. Plug the other end of the cable into the included adapter. Plug the adapter into the LINE OUT jack on your stereo.

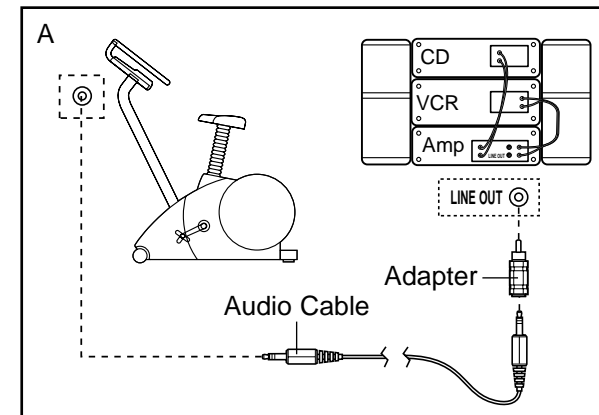

- B. Plug one end of the audio cable into the jack beneath the console of the exercise cycle. Plug the other end of the cable into the included adapter. Plug the adapter into an RCA Y-adapter (available at electronics stores). Next, remove the wire that is currently plugged into the LINE OUT jack on your stereo and plug the wire into the unused side of the RCA Y-adapter. Plug the RCA Y-adapter into the LINE OUT jack on your stereo.

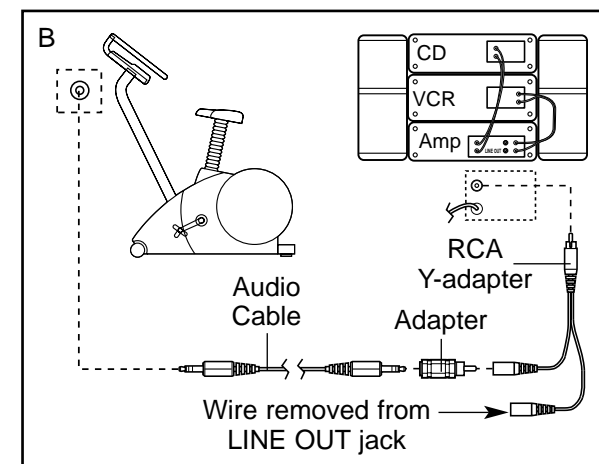

### HOW TO CONNECT YOUR COMPUTER

**Note: If your computer has a 3.5mm LINE OUT jack, see instruction A. If your computer has only a PHONES jack, see instruction B.**

- A. Plug one end of the audio cable into the jack beneath the console of the exercise cycle. Plug the other end of the cable into the LINE OUT jack on your computer.

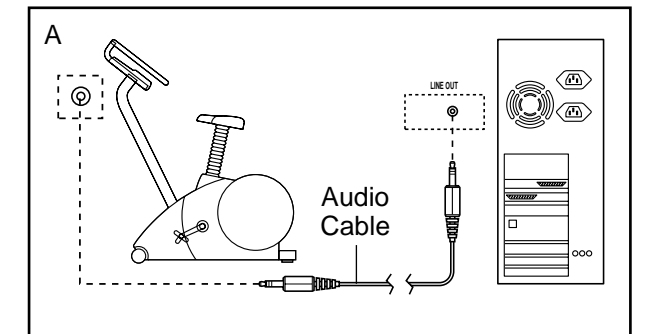

- B. Plug one end of the audio cable into the jack beneath the console of the exercise cycle. Plug the other end of the cable into a 3.5mm Y-adapter (available at electronics stores). Plug the Y-adapter into the PHONES jack on your computer. Plug your headphones or speakers into the other side of the Y-adapter.

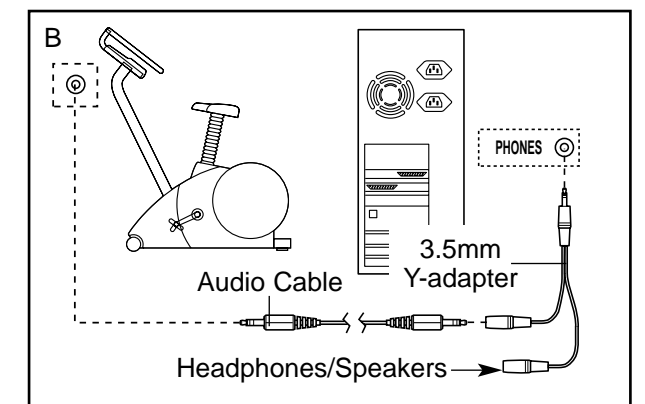

## HOW TO CONNECT YOUR CD PLAYER, VCR, OR COMPUTER

To use iFIT.com CDs, the exercise cycle must be connected to your portable CD player, portable stereo, home stereo, or computer with CD player. See pages 14 to 16 for connecting instructions. To use iFIT.com videocassettes, the exercise cycle must be connected to your VCR. See page 16 for connecting instructions. To use iFIT.com programs directly from our Web site, the exercise cycle must be connected to your home computer. See page 15 for connecting instructions.

## HOW TO CONNECT YOUR PORTABLE CD PLAYER

**Note:** If your CD player has separate LINE OUT and PHONES jacks, see instruction A below. If your CD player has only one jack, see instruction B.

- A. Plug one end of the audio cable into the jack beneath the console of the exercise cycle. Plug the other end of the cable into the LINE OUT jack on your CD player. Plug your headphones into the PHONES jack.

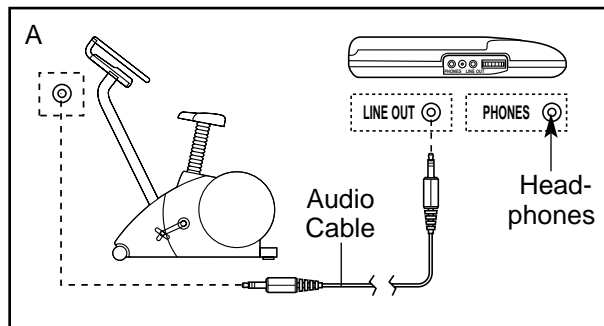

- B. Plug one end of the audio cable into the jack beneath the console of the exercise cycle. Plug the other end of the cable into a 3.5mm Y-adaptor (available at electronics stores). Plug the Y-adaptor into the PHONES jack on your CD player. Plug your headphones into the other side of the Y-adaptor.

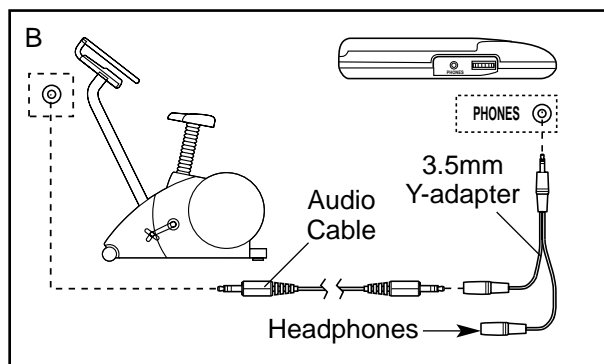

## HOW TO CONNECT YOUR PORTABLE STEREO

**Note:** If your stereo has an RCA-type AUDIO OUT jack, see instruction A below. If your stereo has a 3.5mm LINE OUT jack, see instruction B. If your stereo has only a PHONES jack, see instruction C.

- A. Plug one end of the audio cable into the jack beneath the console of the exercise cycle. Plug the other end of the cable into the included adapter. Plug the adapter into an AUDIO OUT jack on your stereo.

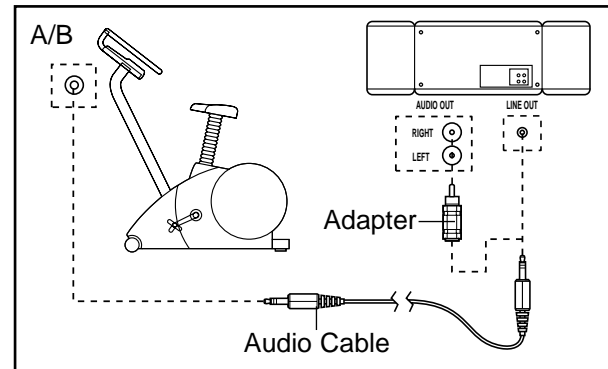

- B. Refer to the drawing above. Plug one end of the audio cable into the jack beneath the console of the exercise cycle. Plug the other end of the cable into the LINE OUT jack on your stereo. Do not use the adapter.

- C. Plug one end of the audio cable into the jack beneath the console of the exercise cycle. Plug the other end of the cable into a 3.5mm Y-adaptor (available at electronics stores). Plug the Y-adaptor into the PHONES jack on your stereo. Plug your headphones into the other side of the Y-adaptor.

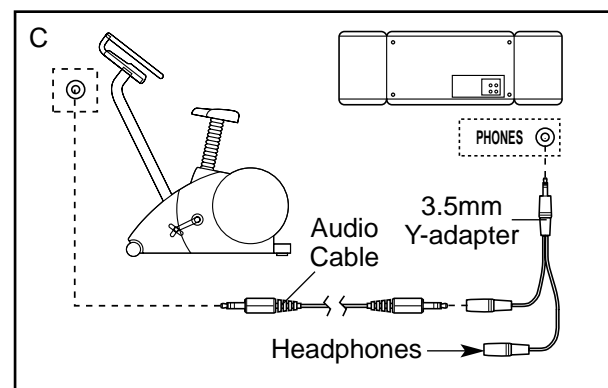

## CONSOLE DESCRIPTION

Refer to the drawing on page 10. **Note:** If there is a thin sheet of clear plastic on the face of the console, remove it.

- A. Exercise feedback display—This display features seven modes that give you instant exercise feedback: your current speed, the elapsed time (or the time remaining in a Smart program), the distance that you have pedaled, the resistance level, the approximate numbers of calories and fat calories you have burned (see FAT BURNING on page 20), and your heart rate (when you use the handgrip pulse sensor or the optional chest pulse sensor [refer to page 18 for information about the chest pulse sensor]). If the scan mode is selected, the display will change from one mode to the next every six seconds. Or, you can select a single mode for continuous display.

**Note:** The console can show speed and distance in either miles or kilometres. To change the unit of measurement, hold down the On/Reset button for six seconds. The mode indicators (see F below) will show which unit of measurement is selected. When the batteries are replaced, it may be necessary to reselect the desired unit of measurement.

- B. Increase and decrease arrows—During Smart programs and iFIT.com programs, these arrows will prompt you to increase or decrease your pace to match the target pace.

- C. Manual mode/program indicators—When a Smart program is selected, the upper right corner of the display will show a 1, 2, 3, 4, 5, 6, 7, or 8, depending on which Smart program is selected. When the iFIT.com mode is selected, the upper right corner will show the letters IF. When the manual mode is selected, the upper right corner will be blank.

- D. Program profiles—These profiles show how the resistance of the exercise cycle and the target pace will change during Smart programs. For example, profile number 6 shows that during Smart program 6, the resistance will gradually increase during the first half of the program, and then gradually decrease during the last half; the target pace will alternately increase and decrease throughout the program.

- E. Warnings—See page 3.

- F. Feedback mode indicators—These indicators show

which feedback mode (scan, speed, time, distance, resistance level, calories, fat calories, or heart rate) is currently shown. **Note:** When the distance is shown, the word Miles or the letters Kms will appear; when your speed is shown, the letters MPH or Km/H will appear.

- G. Pace indicators—When the manual mode is selected, only the left pace indicator will appear. This indicator shows your exercise pace. As you increase or decrease your pace, the indicator will increase or decrease in height. When a Smart program or the iFIT.com mode is selected, both pace indicators will appear. The left indicator will show your actual exercise pace, and the right indicator will show the current target pace. During the program, the target pace will periodically change; as the right indicator changes in height, simply adjust your pace so that both indicators are at the same height. **Important:** The target pace is a goal pace. Your actual pace may be slower than the target pace, especially during the first few months of your exercise program. Make sure to exercise at a pace that is comfortable for you.

- H. On/Reset button—When the console is off, pressing this button will turn on the display. When the console is on, pressing this button will reset the display. This button is also used to select the unit of measurement for speed and distance (see A at the left).

- I. Display Mode button—This button is used to select the feedback modes. The modes will be selected in the following order: scan, speed, time, distance, resistance level, calories, fat calories, and heart rate (when the handgrip pulse sensor or the optional chest pulse sensor is used).

- J. + and – buttons—These buttons control the resistance of the exercise cycle. There are ten resistance levels; level 10 is the most challenging.

- K. Program button—This button is used to select the manual mode and Smart programs.

- L. iFIT.com button—This button is used to select the iFIT.com mode. The indicator on the button will light when the iFIT.com mode is selected.

To use the manual mode of the console, refer to page 12. To use a Smart program, refer to page 13. To use iFIT.com CDs or videos, refer to page 17. To use a program directly from our Web site, refer to page 18.

## HOW TO USE THE MANUAL MODE

### 1 Turn on the console.

Note: The console requires four 1,5 V ("D") batteries (not included). If you have not installed batteries, refer to step 4 on page 6 and install batteries.

To turn on the console, press the On/Reset button or begin pedaling.

### 2 Select the manual mode.

Each time the console is turned on, the manual mode will be selected. If a Smart program or the iFIT.com mode

has been selected, select the manual mode by pressing the Program button repeatedly until the upper right corner of the display is blank.

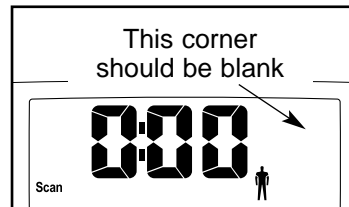

### 3 Begin exercising and adjust the resistance of the exercise cycle.

As you exercise, adjust the resistance of the exercise cycle as desired by pressing the + and - buttons. There are ten resistance levels; level 10 is the most challenging. Note: After the buttons are pressed, it will take a few seconds for the selected setting to be reached.

### 4 Follow your progress with the feedback modes and the left bar graph.

When the console is turned on, the scan mode will be selected. As you exercise, the display will show your current speed, the elapsed time, the distance that you have pedaled, the current resistance level, and the approximate numbers of calories and fat calories you have burned. In addition, your heart rate will be shown when you use the handgrip pulse sensor (refer to step 5 at the right) or the optional chest pulse sensor (refer to page 18).

Note: Each time the resistance level changes, the

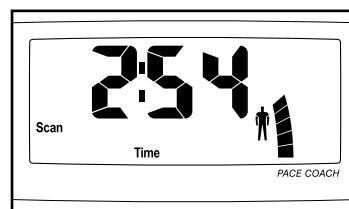

console will show the resistance level for six seconds. When a Smart program is selected, the display will show the time remaining in the program instead of the elapsed time.

In addition, the left pace indicator will appear in the display to show your exercise pace. As you increase or decrease your pace, the indicator will increase or decrease in height.

If desired, you can select a single feedback mode for continuous display. Press the Display Mode button repeatedly until only the MPH (or Km/H), Time, Miles (or Kms), Resist., Cals., or Fat Cals. indicator appears in the display. Make sure that the Scan indicator does not appear.

### 5 Measure your heart rate if desired.

Note: If you wear the optional chest pulse sensor and hold the handgrip pulse sensor at the same time, the console may not display your heart rate accurately.

If there are thin sheets of plastic on the metal contacts on the handgrip pulse sensor, peel off the plastic. To use the handgrip pulse sensor,

place your hands on the metal contacts. Your palms must be on the upper contacts and your fingers must be touching the lower contacts. Avoid moving your hands. When your pulse is detected, the heart-shaped indicator in the display will flash each time your heart beats. After a moment, two dashes (--) will appear and then your heart rate will be shown.

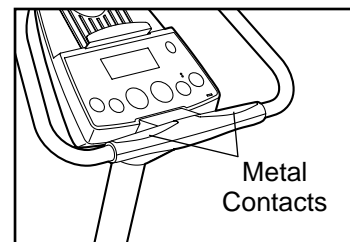

For the most accurate heart rate reading, continue to hold the handgrips for about 15 seconds. Note: When you first hold the handgrips, the display will show your heart rate continuously for 15 seconds. The display will then show your heart rate along with the other feedback modes.

### 6 When you are finished exercising, the console will automatically turn off after a few minutes.

If the pedals are not moved and the console buttons are not pressed for a few minutes, the console will automatically turn off to conserve the batteries.

## HOW TO USE A SMART PROGRAM

### 1 Turn on the console.

Refer to step 1 on page 12.

### 2 Select one of the eight Smart programs.

Each time the console is turned on, the manual mode will be selected. To select a Smart program, press the Program button repeatedly until the number 1, 2, 3, 4, 5, 6, 7, or 8 appears in the upper right corner of the display.

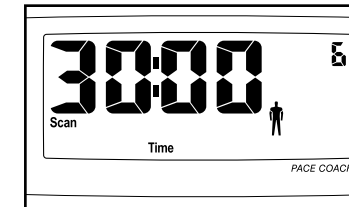

The profiles on the right side of the console show how the resistance of the exercise cycle and the target pace will change during the Smart programs. For example, profile number 6 shows that during Smart program 6, the resistance will gradually increase during the first half of the program, and then gradually decrease during the last half; the target pace will alternately increase and decrease throughout the program.

### 3 Start the program.

To start the program, simply begin exercising. Each Smart program consists of either twenty or thirty, one-minute periods. One resistance setting and one pace setting are programmed for each period. (The same resistance setting and/or pace setting may be programmed for consecutive periods.)

During the program, the resistance of the exercise cycle will automatically change as shown by the applicable profile on the console. If the current resistance level is too high or too low, you

can change the resistance level by pressing the + and - buttons. However, when the current period of the program is completed, the resistance level will automatically change if a different resistance setting is programmed for the next period.

The target pace settings for the program will be shown by the right pace indicator in the display. (The left indicator will show your

actual exercise pace.) As the right indicator changes in height during the program, simply adjust your pace so that both indicators are at the same height. If your pace is slower than the current target pace, the increase arrow will appear in the display to prompt you to increase your pace; if your pace is faster than the target pace, the decrease arrow will appear. **Important: The target pace settings for the program are intended only to provide a goal. Your actual pace may be slower than the target pace settings, especially during the first few months of your exercise program. Make sure to exercise at a pace that is comfortable for you.**

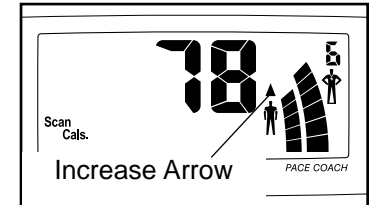

During the program, the display will show the time remaining in the program. If you continue exercising after the program is completed, the display will continue to show your exercise feedback.

### 4 Follow your progress with the feedback modes.

Refer to step 4 on page 12.

### 5 Measure your heart rate if desired.

See step 5 on page 12.

### 6 When you are finished exercising, the console will automatically turn off after a few minutes.

Refer to step 6 on page 12.