

Vinotemp®

A PROUD HERITAGE OF EXPERIENCE & QUALITY

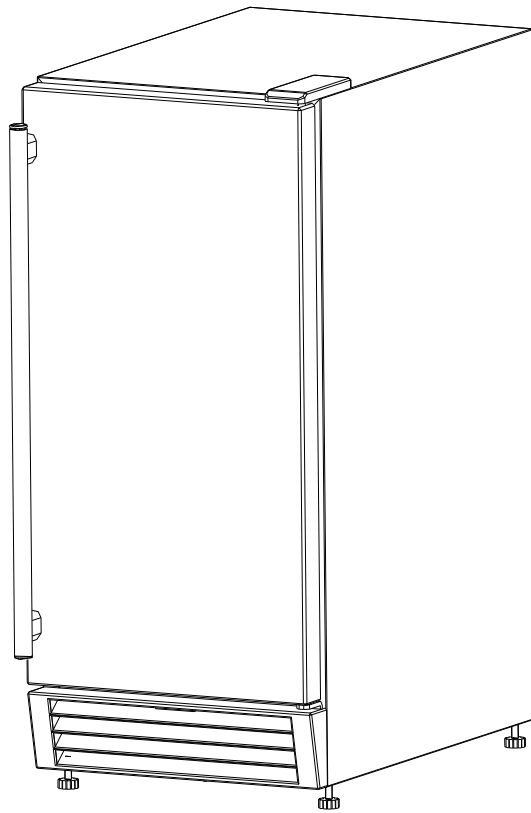

OUTDOOR REFRIGERATOR

VT-REFOUT15

OWNER'S MANUAL



WWW.VINOTEMP.COM

General Operating Instructions

Remove all external and internal packaging from your appliance. Be sure that all parts have been included before discarding any packaging materials. You may want to keep the box and packing materials for use at a later date.

Upon receipt and inspection of unit, the supply cord must be replaced if it is damaged. Contact our customer service at 1-800-777-8466 or info@vinotemp.com.

READ ALL INSTRUCTIONS BEFORE USING THIS APPLIANCE
- Save these instructions -

TABLE OF CONTENTS

IMPORTANT SAFETY INSTRUCTIONS	4
ELECTRICAL CONNECTION	5
CORD INSTRUCTIONS	5
PARTS AND SPECIFICATIONS	6
TECHNICAL DATA	6
INSTALLATION INSTRUCTIONS.....	7
OPERATING YOUR REFRIGERATOR	8
CARE AND MAINTENANCE	9
TROUBLESHOOTING GUIDE	10
TERMS AND CONDITIONS	11
SERVICE & IMPORTANT NOTICE	12

IMPORTANT SAFETY INSTRUCTIONS



To reduce the risk of fire, electrical shock or injury when using your appliance, follow these basic precautions:

- Do not operate this or any other appliance with a damaged cord.
- Always unplug the appliance before performing any care or maintenance.
- Exercise caution and use reasonable supervision when appliance is used near children. Never allow children to operate, play with or crawl inside the appliance. Keep packing materials away from children.
- Do not clean appliance with flammable fluids. Do not store or use gasoline or other flammable vapors and liquids in the vicinity of this or any other appliance. The fumes can create a fire hazard or explosion.
- Do not use solvent-based cleaning agents or abrasives on the interior. These cleaners may damage or discolor the interior.
- Do not operate if housing panels are removed or damaged.
- When disposing of refrigerator appliances, special handling is often required. It is the consumer's responsibility to comply with federal and local regulations when disposing of this product.
- Do not attempt to repair or replace any part of your appliance unless it is specifically recommended in this manual. All other servicing should be referred to a qualified technician.
- Locate the unit away from direct sunlight and sources of heat (stove, heater, radiator, etc).
- To protect against electric shock, do not immerse appliance, plug or cord in water or other liquids. Avoid locating the unit in moist areas. In a rainy environment, a water-proof covering is recommended.
- Do not use this appliance for other than its intended purpose.
- Place the appliance on a solid, level surface. If the unit is placed on a stand, the front surface must be at least 3 inches from the edge of the stand so as to avoid accidental tipping of the appliance during normal usage.
- The unit is an electrical appliance. To avoid injury or death from electrical shock, do not operate the unit with wet hands, while standing on a wet surface or while standing in water.
- Condenser water from evaporator drains into a hole in the floor of the storage compartment and is channeled into a drain pan located at the back of the unit on the compressor. Heat transferred from the compressor evaporates any water that has collected in the pan. Ensure that the drain hole in the floor of the unit is clear and unobstructed.
- During long periods of inactivity, remove the appliance contents and unplug the unit. Clean it and leave the door open slightly to avoid possible formation of condensation, mold or odors.
- Allow unit to stand upright for 24 hours prior to first plugging it in.
- **WARNING:** Risk of child entrapment and suffocation. Before you throw away this or an old unit, remove the door. Leave the shelves in place, so that children may not climb inside.

ELECTRICAL CONNECTION



Improper use of the grounded plug can result in the risk of electrical shock. If the power cord is damaged, frayed or shows cracks or abrasions across its length, have it replaced at an authorized service center.

For your protection, this unit is equipped with a 3-conductor cord set that has a molded 3-prong grounding-type plug, and should be used in combination with a properly connected grounding-type outlet.

- Do not under any circumstances cut or remove the third ground prong from the power cord supplied. For personal safety, this appliance must be properly grounded.
- The cord should be secured behind the unit and not left exposed or dangling to prevent accidental injury.
- Never unplug the unit by pulling the power cord. To disconnect the appliance, always grip the plug firmly and pull straight out from the wall outlet.
- When moving the unit, be careful not to damage the power cord.
- The electrical socket must have good grounding. The ground wire cannot be connected with a gas pipe, heating pipe, water pipe, telephone line or lightning rod. It cannot be replaced with the neutral wire of single-phase power. In addition to the ground wire, an electrical leakage circuit breaker is also required.

CORD INSTRUCTIONS

For your protection, this unit should be properly grounded. Unit is equipped with a 3-conductor cord set that has a molded 3-prong grounding-type plug, and should be used in combination with a properly connected grounding-type outlet as shown in figure A.

It is not recommended to use this unit with an extension cord or power board. Please ensure that the appliance is plugged directly into the electrical outlet.

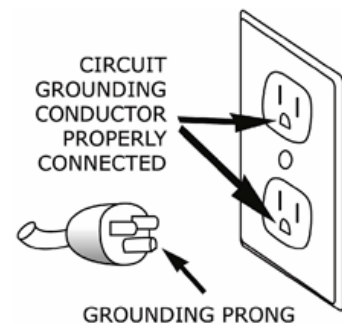

PARTS AND SPECIFICATIONS

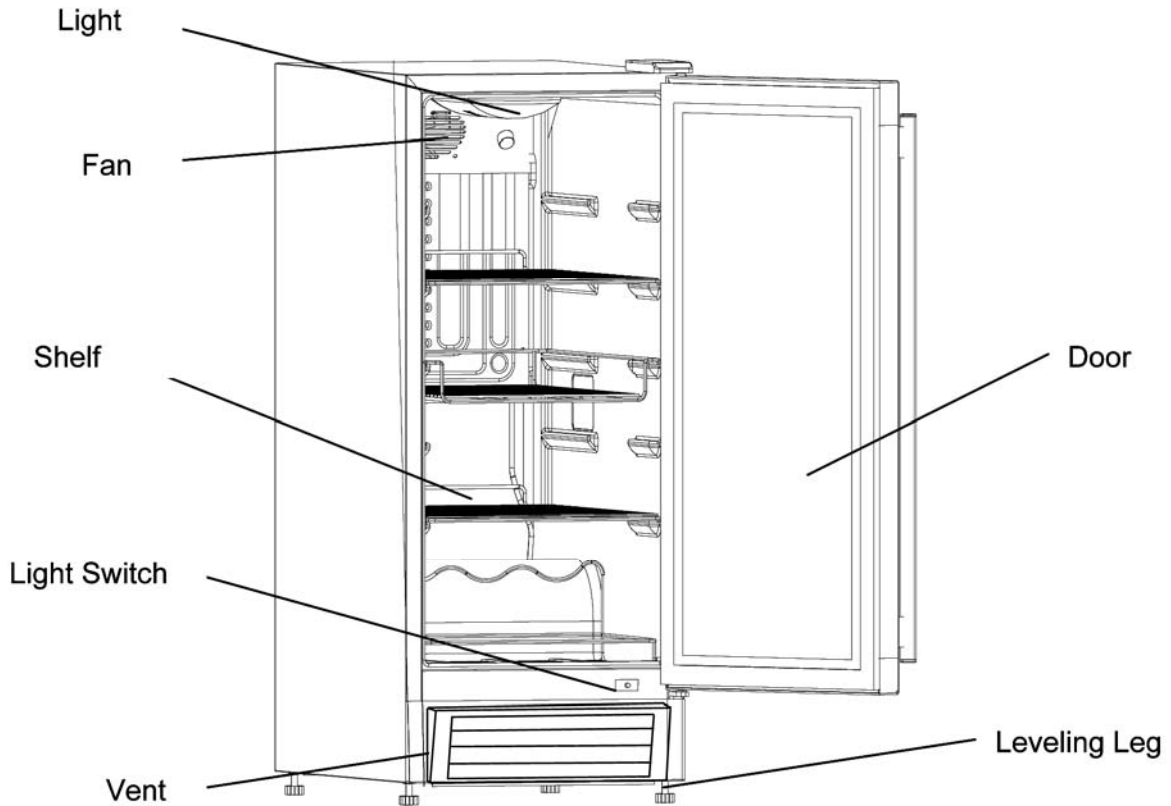

TECHNICAL DATA

Model No.	VT-REFOUT15
Voltage	AC 115V
Frequency	60 Hz
Rated Current	2.0A
Input Power	150W
Power Consumption	1.47kwh/24hr
Refrigerant	R134a, 1.94oz
High/Low side pressure (psig)	190/90
Ambient Temperature Range	25°-100°F
Control Temperature Range	35°- 50°F
Capacity	90L
Approx. Net Weight	69 lbs
Approx. Dimensions (W x D x H)	14.63" x 24.38" x 33.50"

INSTALLATION INSTRUCTIONS

Before Using Your Unit

- Remove all packing material before using your refrigerator.
- Check to be sure the appliance is in good condition and that you have all of the following parts:
 - 3 chrome-plated wire shelves
 - 1 wire basket
 - 1 instruction manual
- Use a soft, dry cloth to wipe down the outside of the refrigerator thoroughly. Clean the interior surface with a soft cloth and lukewarm water.

IMPORTANT: Before connecting the unit to a power source, let it stand upright for approximately 24 hours. This will reduce the possibility of malfunction in the cooling system from handling during transportation.

Locating Your Unit

- Position the refrigerator in a dry and well-ventilated place. Avoid placing the refrigerator near any source of heat or moisture, or in direct sunlight. The recommended ambient temperature should be between 25° and 100°F.
- The refrigerator is designed to be free-standing or built-in. The bottom front vent of the unit should be free of obstruction.
- Place your refrigerator on a solid, level surface (other than carpet). This will ensure vibration and noise-free operation.
- When positioning the refrigerator, leave a minimum clearance of ½ an inch at the back of the unit, 1 inch at the top of the unit and ¼ inch on both sides. This is to ensure proper circulation.

NOTE: Upon plugging the refrigerator into an electrical outlet, let the unit run for at least 30 minutes before making any adjustments.

Installing the legs or casters

Four casters are provided with the refrigerator. They are ideal for rolling the unit from place to place outdoors. Use two or more people when installing or removing casters or legs.

1. Tip unit to the right so there is a ¾-foot clearance at the left of the unit.
2. Remove the leveling legs, and tighten one of the casters with lock in the front screw hole and tighten one of the casters without lock in the back screw hole.
3. Repeat the two steps above with the exception of tipping the unit to the left now, to tighten the other two casters. The casters are now installed.
4. The unit should be level. If the floor conditions do not allow the unit to sit level, adjust the wheel by turning it counter-clockwise to increase the height and clockwise to reduce the height.

OPERATING YOUR REFRIGERATOR

IMPORTANT: Before connecting your refrigerator to the power source, let the unit stand upright for 24 hours. This will reduce the possibility of a malfunction in the cooling system from handling during transportation.

Controls

The refrigerator has a rotary temperature control knob (thermostat) inside the unit featuring three primary settings (**OFF-COLD-COLDEST**), in order of increasing coldness. The refrigerator also has a heater inside the cabinet, and is designed for outdoor use.

NOTE: To prevent excessive strain on the compressor, do not leave the unit at the COLDEST setting for more than an hour at a time.

Turning the Refrigerator On

Turn the temperature control knob (thermostat) clockwise past the OFF setting.

NOTE: If the refrigerator is unplugged or the power is cut off, allow 8 minutes before restarting or plugging it back in. The unit will not operate properly in less than 8 minutes.

Setting the Temperature

Adjusting the thermostat clockwise (toward the COLDEST setting) will result in the compressor running for a longer time to lower the temperature inside the refrigerator.

Initially, set the thermostat to the midpoint between the COLD and COLDEST settings. The compressor will run continuously for a few hours until the internal temperature stabilizes. The compressor will then run normally, turning on and off periodically.

- **Ambient temperature above 40°F:** Turn the thermostat to the range between COLD and COLDEST to cool foods.
- **Ambient temperature below 40°F:** Turn the thermostat counter-clockwise, first to the COLD setting and continue to the OFF setting. The compressor will stop working and the heater will turn on automatically to maintain the temperature at a suitable level.
- **Ambient temperature below 25°F:** Do not use the unit to store anything.

When operating the unit for the first time, allow the internal temperature to stabilize and the compressor to run normally before putting food inside the refrigerator.

NOTE: As cold air falls and warm air rises, there will be a slight temperature variation from the bottom of the unit to the top. The temperature at the bottom of the refrigerator will always be slightly colder.

Internal Light

This unit has an internal light so you can easily see stored items. The light will turn on when the door is open and turn off when the door is closed.

Shelving

The wire racks in the refrigerator are chrome-plated to prevent rust. The unit has 3 adjustable chrome-plated flat wire shelves and a wire basket to hold cans and bottles. These racks are removable and reversible. To remove a rack, remove any cans or bottles from the rack and pull it out until it stops. Then lift up the front of the rack and remove it from the unit.

CARE AND MAINTENANCE

IMPORTANT: Always unplug your refrigerator before cleaning or performing maintenance. Never use harsh cleansers or scouring pads to clean any part of the refrigerator.

Cleaning the Refrigerator

- **Exterior:** Use a cloth dampened with warm soapy water. Dry thoroughly with a soft cloth. To clean the door gasket, use only warm soapy water.
- **Interior:** First remove all food items and the refrigerator shelves and basket. Wash the inside cabinet with a plain water and baking soda solution (about 2 tablespoons of baking soda to a quart of water). Rinse then dry the inside cabinet. Do not use soaps, detergents, powder or spray cleaners which can cause odors inside the refrigerator. Wash the shelves and basket in a mild detergent solution and dry with a soft cloth.

Moving the Refrigerator

- Remove all food items from the refrigerator.
- Securely tape down all loose items inside the refrigerator.
- Turn the leveling screw up to the base to avoid damage.
- Tape the door shut.
- Ensure the unit stays upright during transportation. Protect the outside of the unit with a blanket or similar item.

Changing the Light Bulb

The light bulb can be replaced with any standard U-shaped, 2-pin compact fluorescent bulb of 5, 7 or 9 Watts. Do not use any unusual force to remove the old bulb. No tools should be necessary. Follow steps A through D to remove the old light bulb. To insert the new bulb, reverse steps. Insert the new light bulb into the lamp bracket. Affix the lamp cover onto the bracket by gently pushing it upward into place.

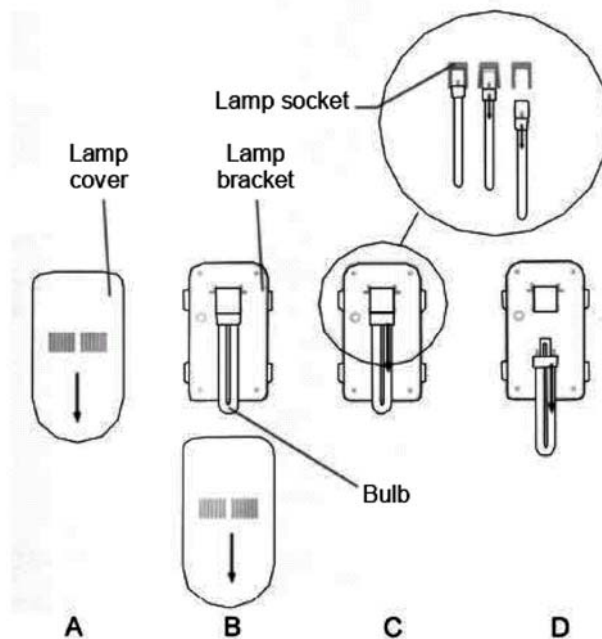

PROBLEMS WITH YOUR REFRIGERATOR

Most common problems can be solved easily, saving you the cost of a possible service call. Try the suggestions below to see if you can solve the problem before contacting Vinotemp at info@vinotemp.com.

TROUBLESHOOTING GUIDE

PROBLEM	POSSIBLE CAUSE
Refrigerator does not turn on	<ul style="list-style-type: none"> • Ensure refrigerator is plugged in to electrical outlet. • Check for a blown fuse. • Check if circuit breaker has been tripped. • Temperature control is set to OFF.
Refrigerator makes too much noise or vibration	<ul style="list-style-type: none"> • Check that the refrigerator is level. Adjust the leveling legs accordingly.
Refrigerator is too warm	<ul style="list-style-type: none"> • Check that refrigerator door is properly closed and sealed. • Check for correct temperature setting. • Ensure that the refrigerator door hasn't been opened too frequently.
Door does not close properly	<ul style="list-style-type: none"> • Check that the refrigerator is level. Adjust the leveling legs accordingly. • The door was reversed and not properly installed. • Check that shelves are not out of position. • Door gasket is dirty.
Light does not work	<ul style="list-style-type: none"> • Check and change the light bulb if necessary.
Refrigerator turns on and off frequently	<ul style="list-style-type: none"> • The ambient temperature may be outside the recommended range. • Check that the door is properly closed and sealed. • Check that refrigerator has proper clearances. • Check for correct temperature setting. • The door is opened too often. • A large amount of food has recently been added to the unit. Give the unit time to adjust.

TERMS AND CONDITIONS

Vinotemp International ("Seller") and the person or entity that acquires these goods from Seller ("Purchaser") hereby fully agree to the following terms and conditions of the sale: Shipping fees are the responsibility of the Purchaser whether freight prepaid or freight collect. Seller assumes no responsibility for the goods sold to the Purchaser once the goods have left the Seller's premises, including, but not limited to, late delivery by the moving carrier, or for events caused by any difficulty carrier incurs in attempting to fit the goods into the Purchaser's place of business or residence due to the size of the goods or otherwise. Purchaser assumes all responsibility for delivery, payment of freight, access, measurement, installation, hook-up, wiring, moving and storage of the goods. The transportation of all goods is subject to the terms and conditions which the moving carrier imposes on Purchaser including, but not limited to, additional charges imposed per flight of stairs, and/or additional charges resulting from the carrier's inability to safely and/or adequately use the building elevator to lift the goods to an upper floor. Any claim for damages incurred during shipment by the carrier of the goods are insured and handled directly with the carrier and must be noted at time of delivery. Any damages due to manufacture defects will be handled directly with Vinotemp International, subject to the limited warranty.

All sales are final, and unless authorized in writing by the Seller, Purchaser may not return the goods, under any circumstance. If Purchaser refuses to accept the goods, under any circumstance, the Purchaser is liable for the return and cost of freight both ways, and if Seller does take back the goods, there will be a restocking charge that is 35% of the purchase price of the goods. (Product must be in original packaging). Built-to-Order products (including Cabinets, Racking, and Accessories) are non-returnable. Purchaser must notify Seller of non-conforming goods within four days of delivery, after which time all goods are deemed accepted. If an order has been placed and production has started, cancellation of your order will be a 15% charge.

If Purchaser tenders payment with a check that has insufficient funds (NSF), or stops payment on a check or credit card for any reason, Purchaser agrees to pay for all costs associated with the Seller's collection or litigation of such a claim, including without limitation extra damages, court costs and attorneys' fees. Finance charges begin the date of invoice. Collection fees plus NSF fee of \$50 will be added to your invoice, which you agree to promptly pay. Title to the goods does not pass until payment is received in full by Seller and Seller retains a security interest in the goods until they are paid for in full.

LIMITED WARRANTY: Seller warrants that the goods will be free of defects in materials and workmanship as follows: Furniture style (wood) wine cabinets: all cooling unit parts for a period of 5 (five) years; cabinetry and labor (uninstalled) for a period of 12 (twelve) months from date of sale. For the metal cabinet wine units: parts and labor for cooling system and cabinetry for a period of 12 (twelve) months from date of sale. Thermoelectric Units: 90 (ninety) days from the date of sale (including Wine Coolers, Beer Dispensers, Humidor, Portofino Wood Cellars, and Refrigerators). Wine-Mate Split Systems and installed products are parts only for 1 year, no labor. Other Wine-Mate Cooling Systems are 5 years parts, 1 year labor. Wine Accessories and Racking Systems are not warranted. For a scratch and dent/refurbished unit, warranty is 3 months from your dated invoice (parts for function only, not cosmetic). There is no warranty on parts purchased separately. Removal and re-installation of unit is not included in warranted labor. Purchaser's exclusive remedy is limited, at Seller's option; to repair or replace defective part[s] with either new or factory reconditioned part[s]. Purchaser is responsible for shipping the unit pre-paid to designated facility and Seller will pay return shipping charges in the continental United States for items repaired under warranty within 12 (twelve) months from date of sale. Since the natural variation in texture, density, grain, color, tone and shade of wood is unavoidable; Seller does not guarantee the texture, color, tone or shade of the wood: nor does seller guarantee the colorfastness of wood or against peeling, chipping, cracking or scratching. Note: Unfinished wood is subject to warping; all wood surfaces must be sealed before placing cellar into service. Improper placement of the unit will void the warranty. By Vinotemp in writing, any third party repair facility must be pre-approved before providing parts free of charge. This limited warranty does not cover damage due to such things as accident, misuse, abuse, mishandling, neglect, acts of God, fires, earthquakes, floods, high winds, government, war, riot or labor trouble, strikes, lockouts, delay of carrier, unauthorized repair, or any other cause beyond the control of the Seller, whether similar or dissimilar to the foregoing. Seller is not responsible for any damages caused to Purchaser's property resulting from the good. This limited warranty applies only inside the Continental US. (Alaska, Puerto Rico and Hawaii are not warranted.)

For Element Grills (via Element Products LLC), grills have a 1 year comprehensive parts warranty on entire product. Three years limited parts warranty covering the stainless burner and a thirty day limited parts warranty on grill accessories. If grill is defective and unused plus all packaging and parts are intact, we will either replace the grill or provide service to repair the grill. Returned product must accompany all original packaging and parts and is subject to our 35% restocking fee (and freight both ways).

With Wine-Mate products, if the customer calls and the product is "defective", you must obtain a letter from your qualified refrigeration technician at the customers cost, to verify that the unit was installed properly, with proper ventilation and the unit is truly malfunctioning due to manufacture defect.

Purchaser understands and acknowledges that the goods sold here are wine cellars, cigar humidors, and/or other similar units which house wine or cigars. Purchaser assumes all risk of using these units, including risk of spoilage, humidity variations, temperature variations, leaks, fire, water damage, mold, mildew, dryness and similar and any other perils that might occur.

Seller is not responsible for incidental or consequential damages, and there are no warranties, expressed or implied, which extend beyond the Limited Warranty described above. The implied warranties of merchantability and of fitness for a particular purpose are hereby expressly disclaimed. Some states do not allow the exclusion of incidental or consequential damages, or a waiver of the implied warranties of fitness and/or merchantability, so the above limitations may not apply to you. This warranty gives you specific legal rights and you may also have other rights which vary from state to state.

In the event of any dispute between Seller and Purchaser arising out of or relating to these terms and conditions or to the goods sold generally, Purchaser must first file a written claim with Seller within ten days of the occurrence giving rise to the claim and wait an additional thirty days for a response before initiating any legal action. The sale and all terms are subject to California law. Any legal proceeding arising out of or relating to these terms and conditions or to the goods sold generally shall be brought solely and exclusively in the County of Los Angeles. In no event may Purchaser initiate any legal proceeding more than six months after the occurrence of the event giving rise to the dispute.

The above terms and conditions are the only ones governing this transaction and Seller makes no oral representations of any kind. These Terms and Conditions can only be modified in writing, signed by both Purchaser and Seller. 10/10

SERVICE & IMPORTANT NOTICE

Upon receipt and inspection of unit, the supply cord must be replaced if it is damaged. Contact our customer service at 1-800-777-8466 or info@vinotemp.com.

The manufacturer has a policy of continuous improvement on its products and reserves the right to change materials and specifications without notice.

WARNING:

**Please do not place the unit within reach of children.
For adult use only.**

Contact info@vinotemp.com with any questions or visit

www.vinotemp.com



17621 S. Susana Road
Rancho Dominguez, CA 90221
www.vinotemp.com

Vinotemp is a registered trademark of Vinotemp International. All products, features, and services are subject to change without notice. We cannot guarantee the accuracy of the contents of this document. We disclaim liability for errors, omissions, or future changes.

© 2011 Vinotemp International. All rights reserved.