

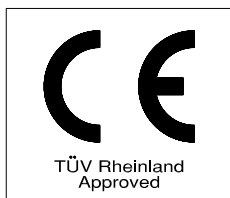

Automatic BANDSAWS

H-330A

FULL STROKE INSTRUCTION MANUAL



MEGA MACHINE CO., LTD.

DOC NO : H330A-FULL-100.U

CTRL NO : 06

UPDATE : 2007/9/13

DOC VER : A1

FOREWORD

We hope that the owner of this automatic circular sawing machine will have years of trouble-free service. The machine has been built to the highest standards to enable fast accurate cutting to be obtained.

In order that the best results can be achieved from your MEGA circular sawing Machine, we would ask all operators and maintenance engineers to **READ THIS MANUAL CAREFULLY BEFORE STARTING THE MACHINE.** The manual contains full instructions on installation, operation, lubrication, maintenance and trouble-shooting.

As MEGA MACHINE COMPANY LIMITED is constantly improving the design of its machines, there may be some instance where this book differs somewhat from the machine with which you are concerned. So, always quote the Serial Number of your machine, when ordering spare parts or in correspondence relating to the machine.

MODEL : H330A

Serial Number :

Request for service and spare parts should be made to :

ADDRESS: NO. 180, INDUSTRIAL ROAD, TAI-PING CITY,
41107 TAICHUNG, TAIWAN R. O. C.

E-MAIL: mega@ms1.hinet.net; mega@mail.mold.net.tw

URL: www.bandsaw.com.tw

TEL: 886 4 22712877(PRES.) FAX:886 4 22715016

TABLE OF CONTENTS

1. Introductory Illustrations

1.1 Principal parts -----	1-1
---------------------------	-----

2. Specifications

2.1 Specifications -----	2-1
--------------------------	-----

3. Installation

3.1 moving and lifting -----	3-1
------------------------------	-----

3.2 Foundation layout and Set-up -----	3-2
--	-----

4. Operation

4.1 Control Panel -----	4-1
-------------------------	-----

4.2 Operating preparation -----	4-3
---------------------------------	-----

4.3 Manual Operation -----	4-4
----------------------------	-----

4.4 Automatic operation -----	4-5
-------------------------------	-----

4.5 Special Operation -----	4-5
-----------------------------	-----

4.6 Break -In Operation -----	4-5
-------------------------------	-----

Addition 1 Amplifying Valve (Optional) -----	4-6
--	-----

5. Maintenance

5.1 Hydraulic Circuit -----	5-1
-----------------------------	-----

5.2 Oiling and Lubrication -----	5-2
----------------------------------	-----

5.3 Others -----	5-3
------------------	-----

6. Trouble Shooting Guide

6.1 Sawing Problems and Solution -----	6-1
--	-----

6.2 Minor Operating Troubles and Remedies -----	6-2
---	-----

6.3 Error information -----	6-3
-----------------------------	-----

7. Reference Charts

7.1 Standard cutting Chart -----	7-1
----------------------------------	-----

7.2 Standard cutting Chart -----	7-2
----------------------------------	-----

7.3 Standard cutting Chart -----	7-3
----------------------------------	-----

Addition 2 Electrical Circuit -----	
-------------------------------------	--

1. INTRODUCTORY ILLUSTRATIONS

1.1 Principal Parts

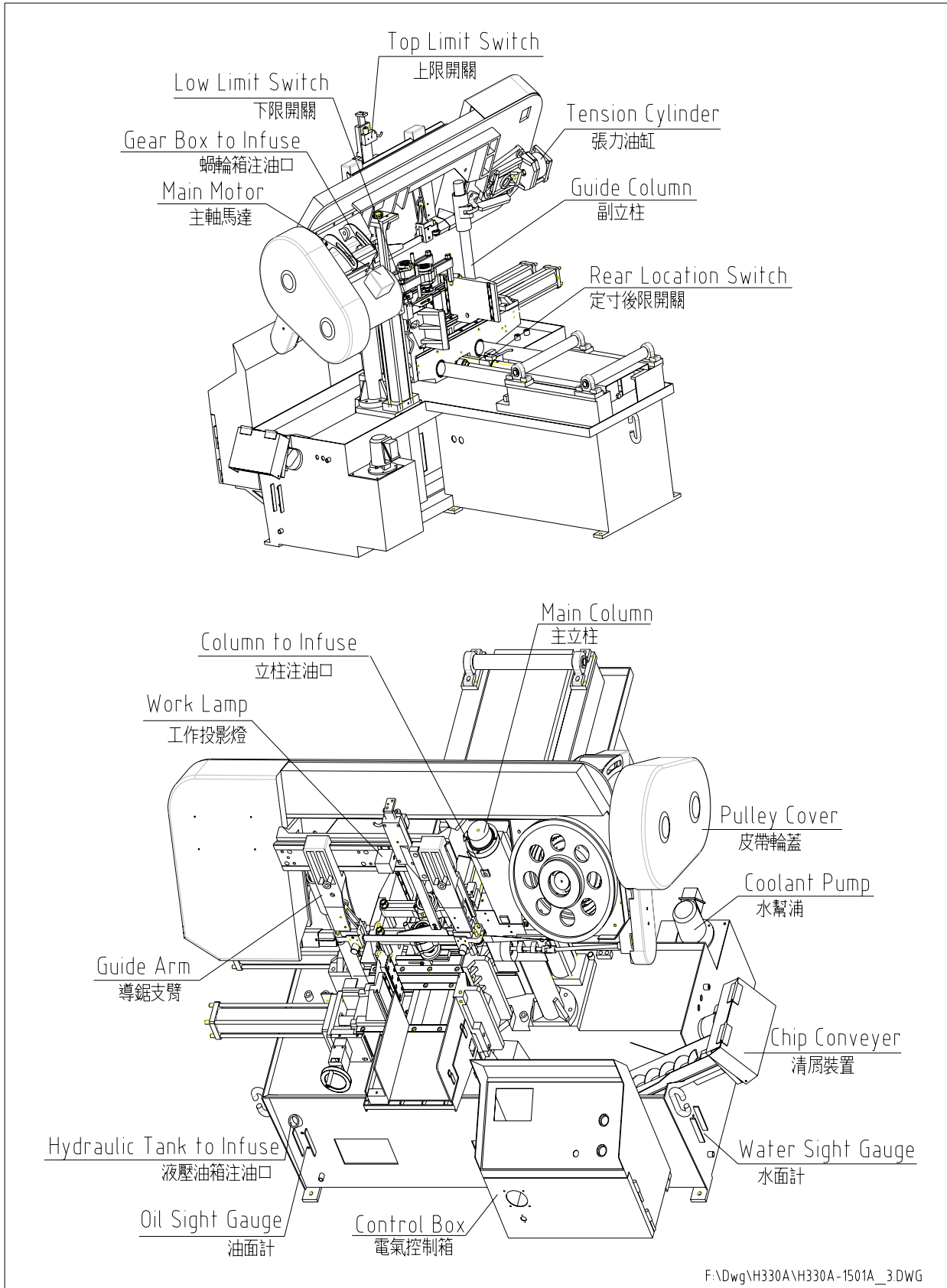

2 SPECIFICATIONS

2.1 SPECIFICATIONS

MODEL		H330A
SPECIFICATIONS		
Cutting Capacity	(Mm)	φ 330 □ 350W*330H
	(In)	φ 13 □ 13.7W*13H
Bundle Cutting	(Mm)	264W*150H
Blade Size	(Mm)	32*1.06*3920
	(In)	1 1/4*0.042*154.33
Blade Speed	(M/Min)	25, 32, 42, 55, 70, 80 Variable Speed 20-80 M/Min
	(F/Min)	82, 105, 138, 180, 230, 260 Variable Speed 65-260F/Min
Motor Output	(KW)	Blade-3.75, HYD-0.75, Coolant-0.1
	(HP)	Blade-5, HYD-1, Coolant- 1/8,
Shipping Volume	(Mm)	2270*2100*1700
	(In)	89.4L*82.7w*66.9H
Weight Net/Gross	KG,lb	1450 KG / 1850 lb. 3190 KG / 4070 lb.

Specifications subject to change without notice for improvement and modification.

2.2 STANDARD ACCESSORIES

1. Tools with tool box 1 set
2. 7 ft.(2M) long roller table 1 set
3. Band-cleaning wire brush 1 pieces
4. Band saw blade 1 piece
5. Vertical guide rollers 1 set
6. Instruction manual 1 copy

3. INSTALLATION :

3.1 Moving and Lifting :

Unpack your machine carefully , and use a crane or forklift to set it in position.

If a crane is used to lift the machine attach the lifting cable carefully to the machine as shown in the fig 2. If forklift is used then fig 3.

Sufficient space should be left around the machine to allow safe handling of materials , and inspection and maintenance operation. Should there be other machinery causing vibration or dust that near your machine, then precautions must be taken to keep your machine away from of vibration and dust.

(1) Use Crane :

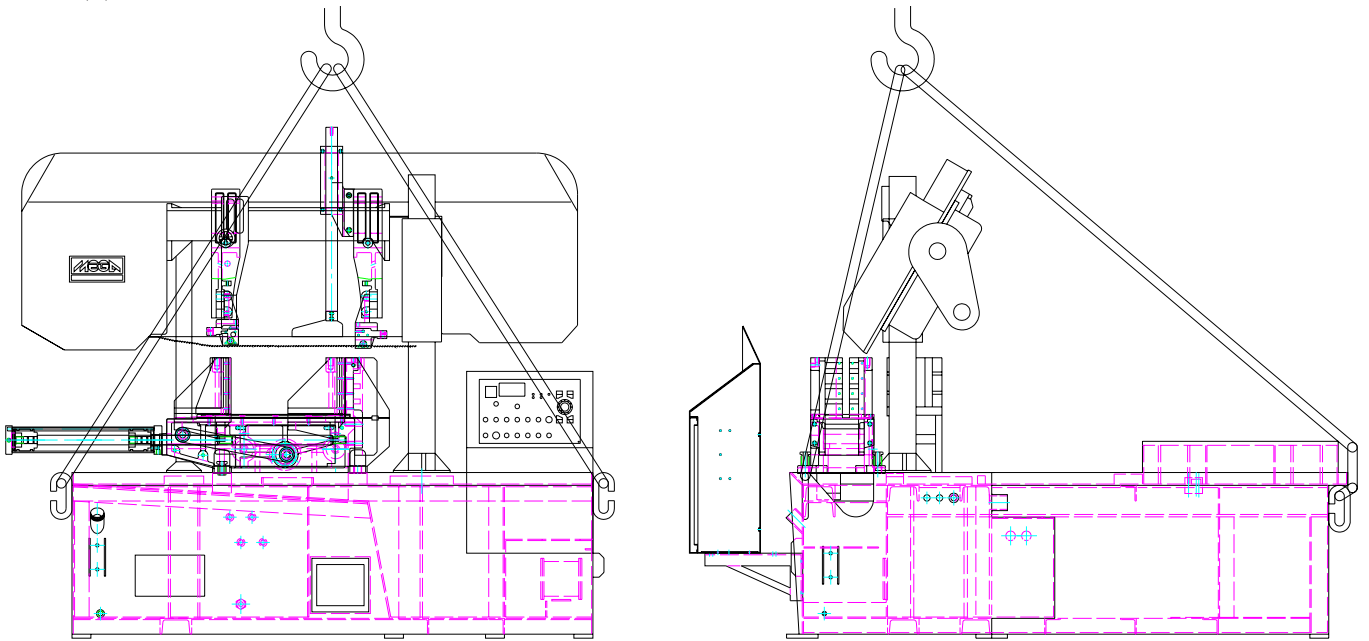

Fig 2

(2) Use Forklift :

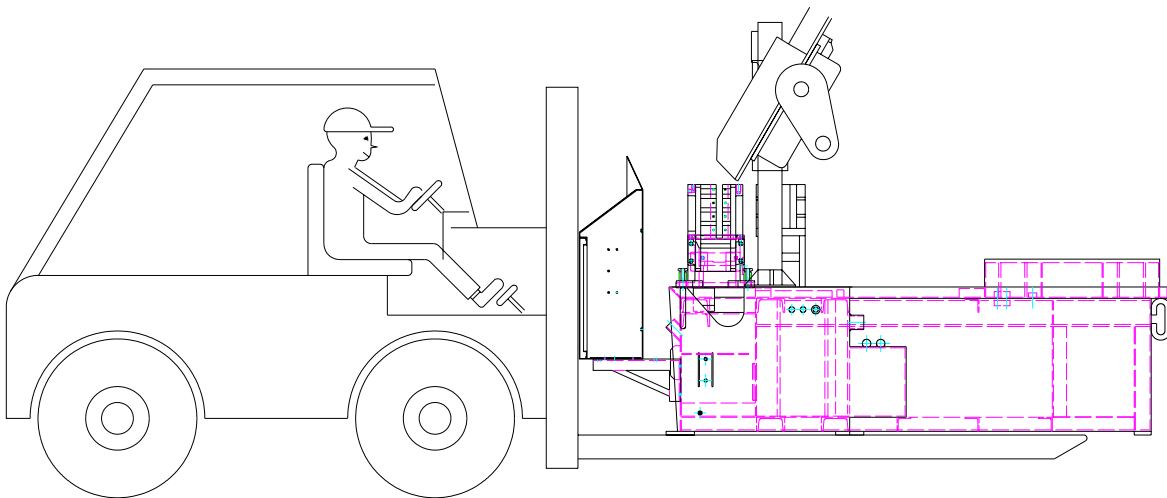

Fig 3

3.2 Foundation layout and set-up :

3.2.1 Foundation :

The foundation should be constructed of reinforced concrete and must be level and flat. After the proper leveling position has been obtained , anchor the machine with anchor bolts.

The position of anchor bolts and floor dimensions are shown in fig 4:

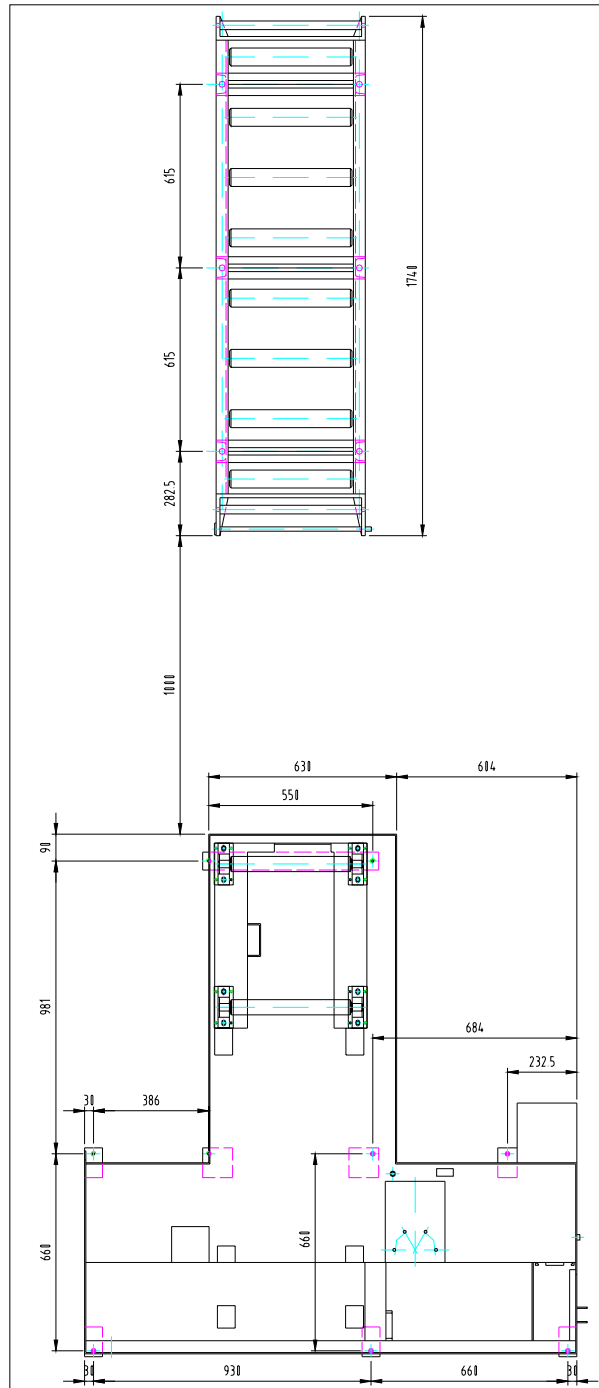

- Contact portion with floor
- Position of anchor bolts

Fig. 4

※ All leveling bolts should support the weight of the machine evenly .

3.2.2 Leveling :

The production accuracy of all precision machinery depends on the accuracy which the machine is installed . Manufacturing tolerance of the machine can only be guaranteed if the machine is firmly and properly installed . Once the machine is lowered on the prepared foundation . Machinist levels should be used alternately on the vice slide plates and the work feed table , and adjust the left-and-right and fore-and-aft level of the machine with leveling bolt .

The fore-and-aft level should be adjusted so that the level of the rear end is approximately 10 mm (3/8" - 1/2") higher than the level of the front end , to provide proper return of the cutting fluid , and easy operation of car feeding .

The left-and-right level should be adjusted so that the level of the left end is approximately 3 mm (1/8") higher than the level of the right end , to provide proper return of the cutting fluid , After the proper leveling position has been obtained anchor the machine with anchor bolts .

CAUTION : All leveling bolts should support the weight of the machine evenly .

Leveling as fig 5 below :

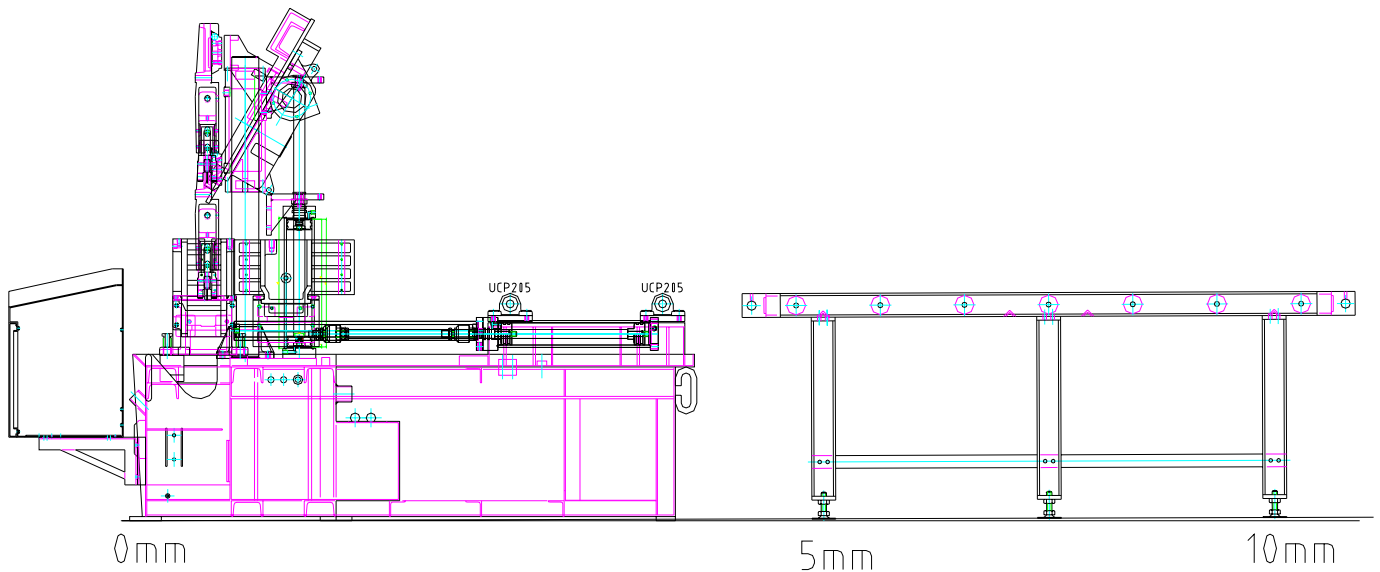

FIG 5

3.2.3 Cleaning and oiling :

After the machine has been placed in position , thoroughly remove its rust preventive coating using a suitable cleaning solvent and then apply a coat of machine oil . To clean the machine , Kerosene is preferable to gasoline . It does not evaporate and level dried slushy compound on finished surfaces. Rags are better than waste as they leave no lint or strings. The machine as received by you. has been completely drained of all oil. Before any attempt is made to run it Before any motor connections are made every detail of the following oiling instruction must be complied with. Refer to the oiling chart in chapter 7.

Especially, don't forget to fill up the cutting fluid mixture.

Usually, the ratio of cutting fluid to water should be 1:30 - 1:50. Check the sight gauge to ascertain the fluid level in the tank every day.

Transmission gear box, bar feed gear box, hydraulic oil tank should to topped up monthly. Oil levels should be strictly observed, for it is of primary importance for proper operation and long lift .

3.2.4 Power Source Connection :

- A. Power Source - This machine is equipped with **5HP main motor** and **1HP hydraulic motor** , and **1/8HP coolant motor**. Connect the power supply cable to the circuit breaker(N.F.B.) terminals. The power supply to your machine should agree with the wiring voltage that is indicated on the label attached to the electrical enclosure and main motor.
- B. Earth - Be sure to connect the earth cable to the earth terminal.
- C. Starting - After making the necessary wiring connections, turn the power switch on the control Panel clockwise to turn power on, depress the vice limit switch (if necessary, e.g. if there is no stock bar clamped in the vice) and push the button to see if the saw head moves upward. If the saw head does not rise , the hydraulic pump motor is rotating in the wrong direction. If the motor runs in the wrong direction, turn off the power switch and disconnect the power supply cable, Then interchange any two phase connections.

4. OPERATION (Type 1)

4.1 Control Panel

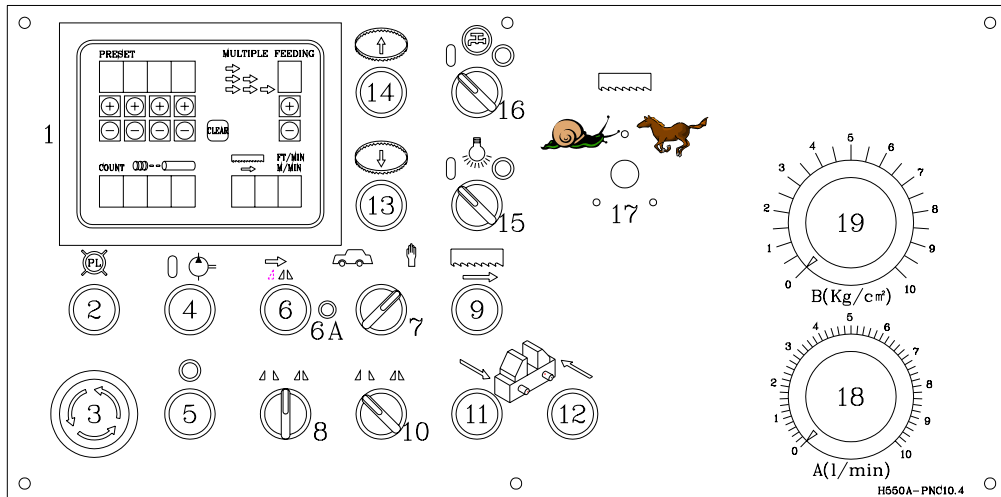

(1) PNC Control Panel

Cutting Piece Counter – This counter is used to preset the number of cuts required on the automatic operation.

When the counter reaches the preset number, the machine stops automatically. To activate the counter, preset the counter switch with number at least “1”.

Clear – This key is used to clear the counted number cut already and to have new number input available.

Multiple stroke feed counter – This counter makes it possible to multiply the number of index cycles when off-cut pieces longer than 400mm are required.

Maximum 9-time stroke can be set.

Blade speed LED-Display -- This blade speed tachometer indicates how fast the saw blade is running in meter per minute by LED display.

To see digital cut length counter

$$S = \frac{L (\text{length req.}) + K (\text{blade thickness})}{N (\text{multiple feed times})} - K$$

EXAMPLE:

$$S = \frac{1200 + 1.5}{3} - 1.5 = 400.5 - 1.5 = 399$$

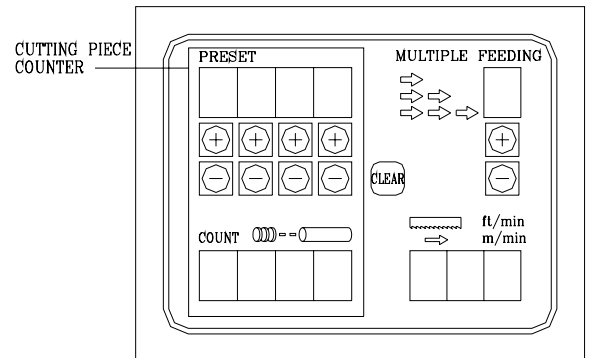

L = Required cut length

K = Cutting loss (Blade thickness)

N = Multiple feeding times

S = Digital counter length setting

Total bar feed needed = length + blade thickness

Single step feed = length + K

Multiple step feed only needs 1 allowance for blade

Thickness ...hence...L + K divided by number of steps

Then less K = Digital counter setting length....

- (2) **PILOT LAMP** -- This light will come on when the power supply is on.
- (3) **EMERGENCY STOP** -- This switch is used for emergency case to stop the machine only.
Turn this switch clockwise makes power source on. When this switch is pressed, all machine's operation stop immediately.
- (4) **HYDRAULIC "ON" BUTTON** -- When this button is depressed, the hydraulic pump motor operates.
- (5) **POWER SWITCH OFF** -- This switch is used for turning off the power by depressing it.
- (6) **FRONT VISE TO CONFIRM SWITCH** -- The front vise clamp the workpiece when turn switch NO.(8) right and press button NO.(6) 1.5sec in the same time. Then the front vise hold the workpiece after the lamp NO.(6A) light.
- (7) **AUTO - MANUAL SELECTOR** -- For continuous cutting , turn this selector to left "AUTO".
To individually operate each function, turn this switch to right "manual".
- (8) **FRONT VISE SWITCH** -- The switch control the front vise jaws in manual mode, The front vise clamp when turn the switch to right. Then if release the switch, the switch come back to the middle position, the vise doesn't hold the workpiece. If operator would like to hold the workpiece, he would follow the (6) illustration.
The front vise open little by little if the guide arm is under the front vise when the switch turn to left. And the front vise open continuously if the guide arm is above the front vise. At last, if release the switch, the switch come back to the middle position.
- (9) **BLADE DRIVE BUTTON** -- When this button is pressed, both the saw blade motor and the cutting fluid pump operate and saw head begins to descend. The saw head descends quickly until the feeler of the quick approach device comes into contact with the workpiece and thereafter, it will descend at the designated cutting speed.
- (10) **REAR VISE SWITCH** -- This switch control the rear vise jaws in manual mode, switched to the left makes the front vise open. and switched to the right makes the front vise clamp.
- (11) **MANUAL FEED FORWARD BUTTON** --When this button is pressed the workpiece moves forward. The workpiece stops advancing when the button is released.
NOTE: Turn (8) **VISE SWITCH** right position before depress switch (9) **BLADE DRIVE** to cutting.
- (12) **MANUAL FEED BACKWARD BUTTON** --When this button is pressed the workpiece moves backward. The workpiece stops moving when the button is released.
NOTE: Don't depress (11) and (12) two switches, if the workpiece are clamped by both front and rear vises in the meantime.
- (13) **QUICK APPROACH BUTTON** -- While this button is pressed, the saw head descends quickly. This button is used to cause the saw blade to approach the work quickly when the saw blade is at a distance from the workpiece. When the feeler of the quick approach device comes into contact with the work, the saw head stops descending at that position even this button is still pressed.
- (14) **SAW FRAME RAISE BUTTON** -- When this button is pressed, the saw blade motor stops and the saw head ascends. The saw head stops ascending at that position when the button is released.
- (15) **WORK BEAM LIGHT SWITCH** -- When this switch is set at "1" the work light illuminates.
- (16) **AUTO CHIP CONVEYOR & COOLANT SWITCH** -- When this switch is set at "1" the cutting fluid pump operates and cutting fluid will be injected even though the saw blade motor is not in operation. Use this switch when removing saw chips with the cutting fluid (without the blade running).
- (17). **INVERTER CONTROL KNOB (OPTIONAL)**-- Please turn left for being slow speed wanted, turn right for being fast speed wanted. Please refer to (JPS) Inverter Instruction Manual or Please refer to (TOSHIBA) Inverter Instruction Manual
- (18) **FEED RATE CONTROL KNOB** -- When this control dial is turned clockwise the feed rate of the cutting increases, when it is turned counter clockwise, the feed rate decreases.
- (19) **CUTTING PRESSURE CONTROL KNOB** -- When this control dial is turned clockwise the cutting pressure increases, when it is turned count clockwise, the cutting pressure decreases.

4. OPERATION (Type 2)

4.1 Control Panel

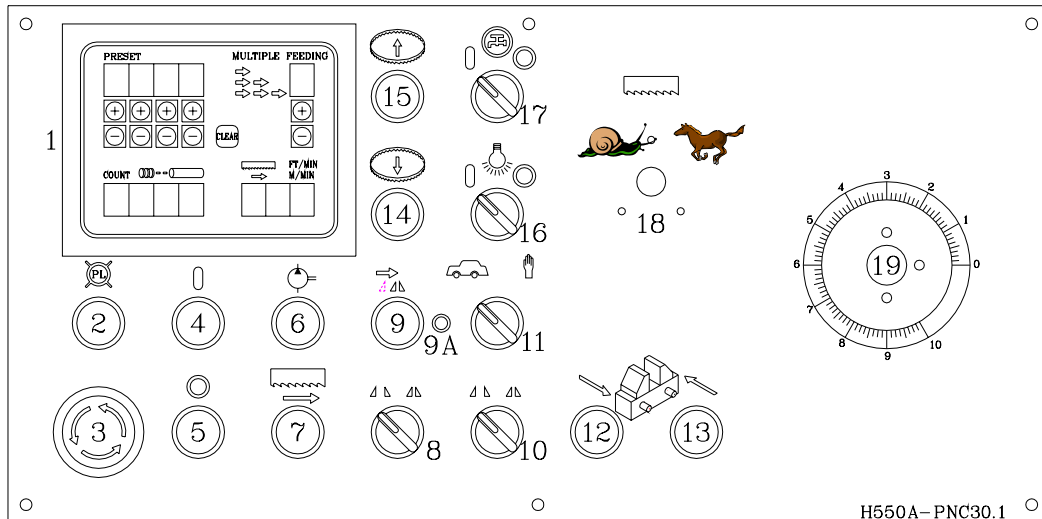

(1) PNC Control Panel

Cutting Piece Counter – This counter is used to preset the number of cuts required on the automatic operation. When the counter reaches the preset number, the machine stops automatically. To activate the counter, preset the counter switch with number at least “1”.

Clear – This key is used to clear the counted number cut already and to have new number input available.

Multiple stroke feed counter – This counter makes it possible to multiply the number of index cycles when off-cut pieces longer than 400mm are required. Maximum 9-time stroke can be set.

Blade speed LED-Display -- This blade speed tachometer indicates how fast the saw blade is running in meter per minute by LED display.

To see digital cut length counter

$$S = \frac{L (\text{length req.}) + K (\text{blade thickness})}{N (\text{multiple feed times})} - K$$

EXAMPLE:

$$S = \frac{1200 + 1.5}{3} - 1.5 = 400.5 - 1.5 = 399$$

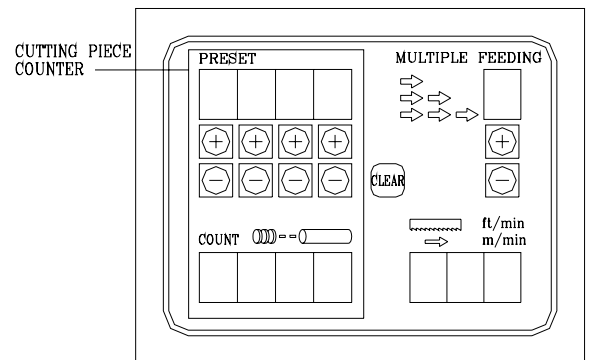

L = Required cut length	N = Multiple feeding times
K = Cutting loss (Blade thickness)	S = Digital counter length setting

Total bar feed needed = length + blade thickness

Single step feed = length + K

Multiple step feed only needs 1 allowance for blade

Thickness ...hence...L + K divided by number of steps

Then less K = Digital counter setting length....

- (2) **PILOT LAMP** -- This light will come on when the power supply is on.
- (3) **EMERGENCY STOP** -- This switch is used for emergency case to stop the machine only.
Turn this switch clockwise makes power source on. When this switch is pressed, all machine's operation stop immediately.
- (4) **POWER SWITCH ON** -- This switch is used for turning on the power by depressing it.
- (5) **POWER SWITCH OFF** -- This switch is used for turning off the power by depressing it.
- (6) **HYDRAULIC "ON" LAMP** -- When NO.(4) button is depressed, the hydraulic pump motor operates. This lamp is light.
- (7) **BLADE DRIVE BUTTON** -- When this button is pressed, both the saw blade motor and the cutting fluid pump operate and saw head begins to descend. The saw head descends quickly until the feeler of the quick approach device comes into contact with the workpiece and thereafter, it will descend at the designated cutting speed.
- (8) **FRONT VISE SWITCH** -- The switch control the front vise jaws in manual mode, The front vise clamp when turn the switch to right. Then if release the switch, the switch come back to the middle position, the vise doesn't hold the workpiece. If operator would like to hold the workpiece, he would follow the (9) illustration.
The front vise open little by little if the guide arm is under the front vise when the switch turn to left. And the front vise open continuously if the guide arm is above the front vise. At last, if release the switch, the switch come back to the middle position.
- (9) **FRONT VISE TO CONFIRM SWITCH** -- The front vise clamp the workpiece when turn switch NO.(8) right and press button NO.(9) 1.5sec in the same time. Then the front vise hold the workpiece after the lamp NO.(9A) light.
- (10) **REAR VISE SWITCH** -- This switch control the rear vise jaws in manual mode, switched to the left makes the front vise open. and switched to the right makes the front vise clamp.
- (11) **AUTO - MANUAL SELECTOR** -- For continuous cutting , turn this selector to left "AUTO".
To individually operate each function, turn this switch to right "manual".
- (12) **MANUAL FEED FORWARD** --When this button is pressed the workpiece moves forward.
The workpiece stops advancing when the button is released.
NOTE: Turn (8) VISE SWITCH right position before depress switch (7) BLADE DRIVE to cutting.
- (13) **MANUAL FEED BACKWARD** --When this button is pressed the workpiece moves backward.
The workpiece stops moving when the button is released.
NOTE: Don't depress (12) and (13) two switches, if the workpiece are clamped by both front and rear vises in the meantime.
- (14) **QUICK APPROACH BUTTON** -- While this button is pressed, the saw head descends quickly.
This button is used to cause the saw blade to approach the work quickly when the saw blade is at a distance from the workpiece. When the feeler of the quick approach device comes into contact with the work, the saw head stops descending at that position even this button is still pressed.
- (15) **SAW FRAME RAISE BUTTON** -- When this button is pressed, the saw blade motor stops and the saw head ascends. The saw head stops ascending at that position when the button is released.
- (16) **WORK BEAM LIGHT SWITCH** -- When this switch is set at "1" the work light illuminates.
- (17) **COOLANT SWITCH** -- When this switch is set at "1" the cutting fluid pump operates and cutting fluid will be injected even though the saw blade motor is not in operation.
Use this switch when removing saw chips with the cutting fluid (without the blade running).
- (18) **INVERTER CONTROL KNOB (OPTIONAL)**-- Please turn left for being slow speed wanted, turn right for being fast speed wanted. Please refer to (JPS) Inverter Instruction Manual or Please refer to (TOSHIBA) Inverter Instruction Manual
- (19) **FEED RATE CONTROL KNOB** -- When this control dial is turned clockwise the feed rate of the cutting increases, when it is turned counter clockwise, the feed rate decreases.

4. OPERATION (Type 3)

4.1 Control Panel

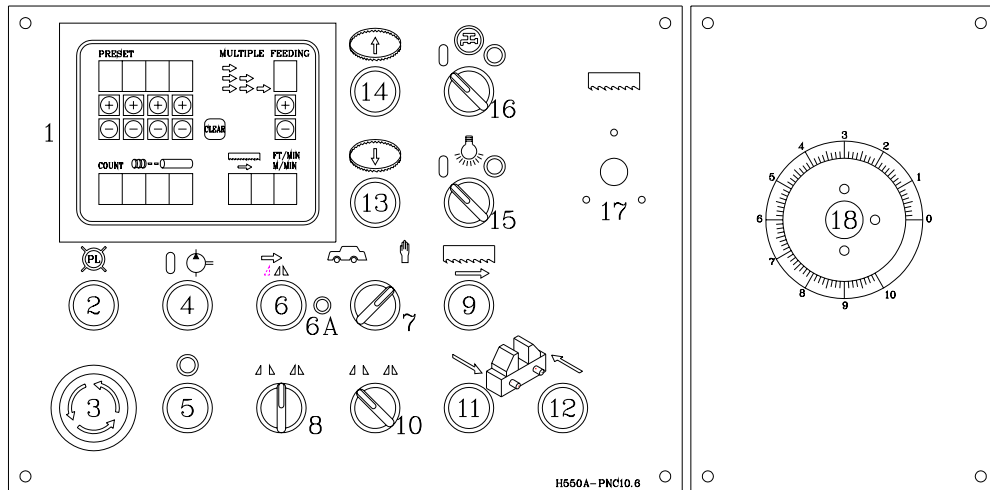

PATH F:\DWG\H550A\Pnc-10

(1) PNC Control Panel

Cutting Piece Counter – This counter is used to preset the number of cuts required on the automatic operation. When the counter reaches the preset number, the machine stops automatically. To activate the counter, preset the counter switch with number at least “1”.

Clear – This key is used to clear the counted number cut already and to have new number input available.

Multiple stroke feed counter – This counter makes it possible to multiply the number of index cycles when off-cut pieces longer than 400mm are required. Maximum 9-time stroke can be set.

Blade speed LED-Display -- This blade speed tachometer indicates how fast the saw blade is running in meter per minute by LED display.

To see digital cut length counter

$$S = \frac{L (\text{length req.}) + K (\text{blade thickness})}{N (\text{multiple feed times})} - K$$

EXAMPLE:

$$S = \frac{1200 + 1.5}{3} - 1.5 = 400.5 - 1.5 = 399$$

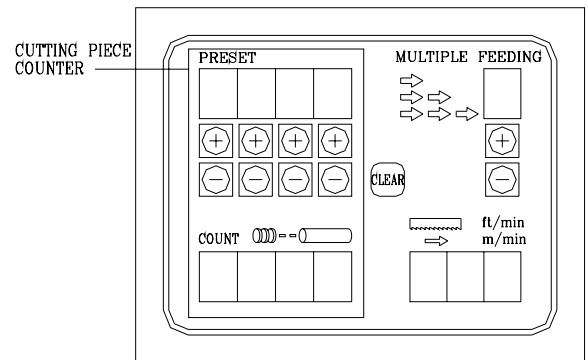

L = Required cut length	N = Multiple feeding times
K = Cutting loss (Blade thickness)	S = Digital counter length setting

Total bar feed needed = length + blade thickness

Single step feed = length + K

Multiple step feed only needs 1 allowance for blade

Thickness ...hence...L + K divided by number of steps

Then less K = Digital counter setting length....

- (2) **PILOT LAMP** -- This light will come on when the power supply is on.
- (3) **EMERGENCY STOP** -- This switch is used for emergency case to stop the machine only.
Turn this switch clockwise makes power source on. When this switch is pressed, all machine's operation stop immediately.
- (4) **HYDRAULIC "ON" BUTTON** -- When this button is depressed, the hydraulic pump motor operates.
- (5) **POWER SWITCH OFF** -- This switch is used for turning off the power by depressing it.
- (6) **FRONT VISE TO CONFIRM SWITCH** -- The front vise clamp the workpiece when turn switch NO.(8) right and press button NO.(6) 1.5sec in the same time. Then the front vise hold the workpiece after the lamp NO.(6A) light.
- (7) **AUTO - MANUAL SELECTOR** -- For continuous cutting, turn this selector to left "AUTO".
To individually operate each function, turn this switch to right "manual".
- (8) **FRONT VISE SWITCH** -- The switch control the front vise jaws in manual mode, The front vise clamp when turn the switch to right. Then if release the switch, the switch come back to the middle position, the vise doesn't hold the workpiece. If operator would like to hold the workpiece, he would follow the (6) illustration.
The front vise open little by little if the guide arm is under the front vise when the switch turn to left. And the front vise open continuously if the guide arm is above the front vise. At last, if release the switch, the switch come back to the middle position.
- (9) **BLADE DRIVE BUTTON** -- When this button is pressed, both the saw blade motor and the cutting fluid pump operate and saw head begins to descend. The saw head descends quickly until the feeler of the quick approach device comes into contact with the workpiece and thereafter, it will descend at the designated cutting speed.
- (10) **REAR VISE SWITCH** -- This switch control the rear vise jaws in manual mode, switched to the left makes the front vise open. and switched to the right makes the front vise clamp.
- (11) **MANUAL FEED FORWARD BUTTON** --When this button is pressed the workpiece moves forward. The workpiece stops advancing when the button is released.
NOTE: Turn (8) **VISE SWITCH** right position before depress switch (9) **BLADE DRIVE** to cutting.
- (12) **MANUAL FEED BACKWARD BUTTON** --When this button is pressed the workpiece moves backward. The workpiece stops moving when the button is released.
NOTE: Don't depress (11) and (12) two switches, if the workpiece are clamped by both front and rear vises in the meantime.
- (13) **QUICK APPROACH BUTTON** -- While this button is pressed, the saw head descends quickly. This button is used to cause the saw blade to approach the work quickly when the saw blade is at a distance from the workpiece. When the feeler of the quick approach device comes into contact with the work, the saw head stops descending at that position even this button is still pressed.
- (14) **SAW FRAME RAISE BUTTON** -- When this button is pressed, the saw blade motor stops and the saw head ascends. The saw head stops ascending at that position when the button is released.
- (15) **WORK BEAM LIGHT SWITCH** -- When this switch is set at "1" the work light illuminates.
- (16) **AUTO CHIP CONVEYOR & COOLANT SWITCH** -- When this switch is set at "1" the cutting fluid pump operates and cutting fluid will be injected even though the saw blade motor is not in operation. Use this switch when removing saw chips with the cutting fluid (without the blade running).
- (17). **INVERTER CONTROL KNOB (OPTIONAL)**-- Please turn left for being slow speed wanted, turn right for being fast speed wanted. Please refer to (JPS) Inverter Instruction Manual or Please refer to (TOSHIBA) Inverter Instruction Manual
- (18) **FEED RATE CONTROL KNOB** -- When this control dial is turned clockwise the feed rate of the cutting increases, when it is turned counter clockwise, the feed rate decreases.

4. OPERATION (Type 4)

4.1 Control Panel

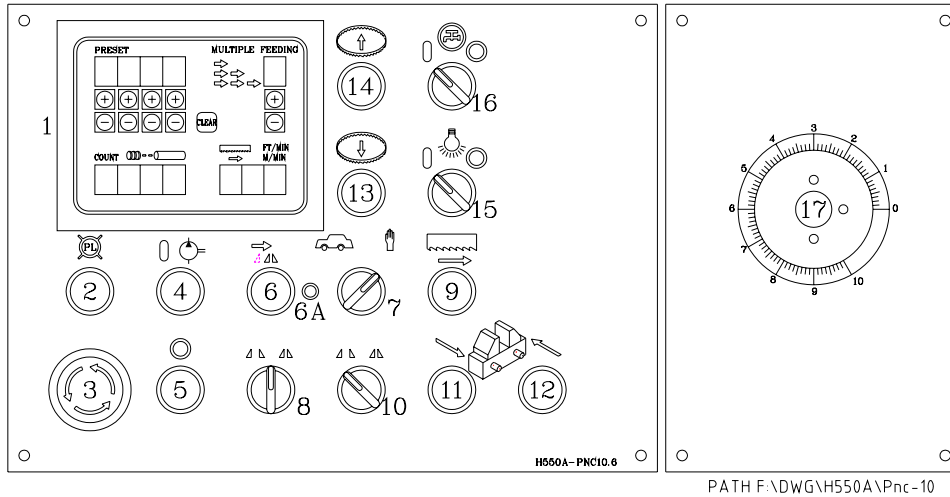

(1) PNC Control Panel

Cutting Piece Counter – This counter is used to preset the number of cuts required on the automatic operation. When the counter reaches the preset number, the machine stops automatically. To activate the counter, preset the counter switch with number at least “1”.

Clear – This key is used to clear the counted number cut already and to have new number input available.

Multiple stroke feed counter – This counter makes it possible to multiply the number of index cycles when off-cut pieces longer than 500mm are required. Maximum 9-time stroke can be set.

Blade speed LED-Display -- This blade speed tachometer indicates how fast the saw blade is running in meter per minute by LED display.

To see digital cut length counter

$$S = \frac{L (\text{length req.}) + K (\text{blade thickness})}{N (\text{multiple feed times})} - K$$

EXAMPLE:

$$S = \frac{1200 + 1.5}{3} - 1.5 = 400.5 - 1.5 = 399$$

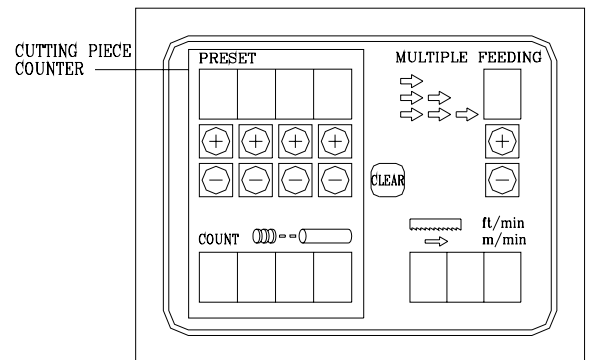

L = Required cut length

K = Cutting loss (Blade thickness)

N = Multiple feeding times

S = Digital counter length setting

Total bar feed needed = length + blade thickness

Single step feed = length + K

Multiple step feed only needs 1 allowance for blade

Thickness ...hence...L + K divided by number of steps

Then less K = Digital counter setting length....

- (2) **PILOT LAMP** -- This light will come on when the power supply is on.
- (3) **EMERGENCY STOP** -- This switch is used for emergency case to stop the machine only.
Turn this switch clockwise makes power source on. When this switch is pressed, all machine's operation stop immediately.
- (4) **HYDRAULIC "ON" BUTTON** -- When this button is depressed, the hydraulic pump motor operates.
- (5) **POWER SWITCH OFF** -- This switch is used for turning off the power by depressing it.
- (6) **FRONT VISE TO CONFIRM SWITCH** -- The front vise clamp the workpiece when turn switch NO.(8) right and press button NO.(6) 1.5sec in the same time. Then the front vise hold the workpiece after the lamp NO.(6A) light.
- (7) **AUTO - MANUAL SELECTOR** -- For continuous cutting, turn this selector to left "AUTO".
To individually operate each function, turn this switch to right "manual".
- (8) **FRONT VISE SWITCH** -- The switch control the front vise jaws in manual mode, The front vise clamp when turn the switch to right. Then if release the switch, the switch come back to the middle position, the vise doesn't hold the workpiece. If operator would like to hold the workpiece, he would follow the (6) illustration.
The front vise open little by little if the guide arm is under the front vise when the switch turn to left. And the front vise open continuously if the guide arm is above the front vise. At last, if release the switch, the switch come back to the middle position.
- (9) **BLADE DRIVE BUTTON** -- When this button is pressed, both the saw blade motor and the cutting fluid pump operate and saw head begins to descend. The saw head descends quickly until the feeler of the quick approach device comes into contact with the workpiece and thereafter, it will descend at the designated cutting speed.
- (10) **REAR VISE SWITCH** -- This switch control the rear vise jaws in manual mode, switched to the left makes the front vise open. and switched to the right makes the front vise clamp.
- (11) **MANUAL FEED FORWARD BUTTON** --When this button is pressed the workpiece moves forward. The workpiece stops advancing when the button is released.
NOTE: Turn (8) **VISE SWITCH** right position before depress switch (9) **BLADE DRIVE** to cutting.
- (12) **MANUAL FEED BACKWARD BUTTON** --When this button is pressed the workpiece moves backward. The workpiece stops moving when the button is released.
NOTE: Don't depress (11) and (12) two switches, if the workpiece are clamped by both front and rear vises in the meantime.
- (13) **QUICK APPROACH BUTTON** -- While this button is pressed, the saw head descends quickly. This button is used to cause the saw blade to approach the work quickly when the saw blade is at a distance from the workpiece. When the feeler of the quick approach device comes into contact with the work, the saw head stops descending at that position even this button is still pressed.
- (14) **SAW FRAME RAISE BUTTON** -- When this button is pressed, the saw blade motor stops and the saw head ascends. The saw head stops ascending at that position when the button is released.
- (15) **WORK BEAM LIGHT SWITCH** -- When this switch is set at "1" the work light illuminates.
- (16) **AUTO CHIP CONVEYOR & COOLANT SWITCH** -- When this switch is set at "1" the cutting fluid pump operates and cutting fluid will be injected even though the saw blade motor is not in operation. Use this switch when removing saw chips with the cutting fluid (without the blade running).
- (17) **FEED RATE CONTROL** -- When the control dial is turned counter clockwise, the feed rate of the saw blade increases, when it is turned clockwise, the feed rate depresses.

4.2 OPERATING PREPARATION

There are several steps will be taken before start the machine.

(1) CHOOSE PROPER SAW BLADE :

Select the saw blade best suited to the workpiece to be cut, Size and shape of the workpiece , and type of material should all be considered when selecting the saw blade to be used . There is a refernce chart in chapter 9 which can help you to select the right saw blade and cutting conditions .

(2) UNPACK THE SAW BLADE :

Usually the saw blade is packed in 3 circle ,unpack it one circle first grip the part to release another 2 circles gradually , tear off the saw-cap protective shield , inspect the blade teeth , make sure that the cutting edge of the blade teeth point to the right . If they point to the left the blade should be turned over.

(3) PLACE THE SAW BLADE ONTO BOTH THE DRIVE AND DRIVEN WHEELS ----

- a. Turn the hydraulic blade tension handle clockwise , to fully loosen the driven wheel .
- b. Open both the drive and driven wheel covers , place the saw blade onto both the drive and driven wheels. Check the cutting edge of the saw blade , to ensure that it point to the right.
- c. Insert the saw blade into both the left and right blade guides so that the back edge of the saw blade touches the back-up roller of each guide .
- d. The back edge of the saw blade should make contact with the flange of the drive and driven wheel , turn count -clockwise the hydraulic blade tension handle to tighten the saw blade , Then the blade is properly tensioned .
- e. Don't forget to tighten the insert adjusting screw .

(4) WORKPIECE CLAMPING :

- a. Raise the saw frame , open the vise , place the workpiece on the roller table .
- b. Gently push the workpiece into the roller-feed vise, taking care not hit the feed rollers.
- c. Clamp the workpiece in vise.

(5) ADJUST THE BLADE GUIDE ARM :

Properly position the blade guide arms according to the diameter (or the width) of the workpiece to be cut.

- a. loosen the insert adjusting screw.
- b. loosen the lock lever of the blade guide arm, and manually move the blade guide arm to suit the width of material using the scale provided.
- c. After adjusting the blade guide arm position ,tighten the lock lever.
- d. Finger tighten the insert adjusting screw.

(6) ADJUST THE POSITION OF THE WIRE BRUSH :

- a. loosen the lock lever of the wire brush case.
- b. Manually move the wire brush case so that wire brush just contacts the cutting edge of the saw blade.
- c. Tighten the lock lever.

(7) ADJUST THE FEED RATE :

Select suitable feed rate for the workpiece to be cut. This varies according to the size and shape of the workpiece, type of material, and what type of saw blade is being used. As a guide hard materials, wide workpiece or structural sections and tubing have to be cut at a slower rate than mild steel bar.

As concerns the saw blade, high speed steel is better than carbon steel, and bi-metal alloy is better than high speed steel. Roughly the ratio of feed speeds could be 1:2:3

(8) CUTTING LENGTH PRESET :

To preset the length of the workpiece to be cut, use the precise cutting piece counter which is at front left side of the machine.

a. Turn the handle wheel and watch the counter to the length you want to cut. The calibration is 0.10 mm. for example: 400.1 mm

b. Tighten the lock screw.

(9) SELECT THE SAW BLADE SPEED :

There are 6 speeds provided : 25, 32, 42, 55, 70, 80 M/min

If an optional variable speed drive is equipped the speed to be 20 to 80 M/Min steplessly.

4.3 MANUAL OPERATION :

Place the workpiece to be cut on the work table, decide how long you want the off-cut, and carry out all the procedures as described above in [4.2] Operating Preparation.

- (1) Depress the RAISE button to lift the saw frame until the cutting edge of the saw blade clears the workpiece by 1/2 to 3/4 inch.
- (2) Turn the AUTO-MANUAL selector to manual.
- (3) Adjust the spacing of the blade guide arms.
- (4) Preset the required cutting length of the workpiece.
- (5) *In control panel – The front vise clamp the workpiece when turn switch NO.(8) right and press button NO.(6) 1.5sec in the same time. Then the front vise hold the workpiece after the lamp NO.(6A) light.*
- (6) *Confirm the procedure (5), then clamp the workpiece.*
- (7) Adjust the FEED RATE.
- (8) *Confirm to clamp the workpiece in procedure (5), then depress BLADE DRIVE button to start both the saw blade motor and the cutting fluid pump and the saw frame begins to descend.*
- (9) After completion of the cut saw blade stops at the lower limit position.
- (10) Depress the RAISE button to cut next piece again.

***. Before you start to cut the workpiece, you must inspect that....**

- a.** The workpiece is well clamped.
- b.** The saw blade is suitable for the material being cut.
- c.** The feed rate is suitable for the material being cut.
- d.** The speed of the saw blade is suitable for the material being cut.
- e.** The insert adjusting screw and the lock lovers of the blade guide arms are all tightened.
- f.** Sufficient tension is placed on the saw blade.
- g.** The wire brush is properly positioned.
- h.** There is sufficient cutting fluid in good condition.
- i.** The off-cut length is as required.

4.4 AUTOMATIC OPERATION :

Having finished all the procedures described above in (2) Operating Preparation ,and with the workpiece to be cut placed in the vise of the machine , but NOT under the saw blade.

- (1) Turn the AUTO-MANUAL selector to manual. ***In control panel – The front vise clamp the workpiece when turn switch NO.(8) right and press button NO.(6) 1.5sec in the same time. Then the front vise hold the workpiece after the lamp NO.(6A) light.***
- (2) Turn the AUTO-MANUAL selector to auto.
- (3) Depress the QUICK APPROACH switch to make the saw frame descend quickly to touch the lower limit position , it will then rise automatically to the freight preset.
- (4) Preset the number of cuts required.
- (5) ***Confirm to clamp the workpiece in procedure (1) and (2).***
- (6) Depress the BLADE DRIVE button to start both the saw blade motor and the cutting fluid pump. The saw frame begins to descend to cut workpiece.
- (7) After the required number of cut has been completed, the saw frame will lift to the raised position and all machine operation will stop.
- (8) The machine will automatically stop, when the workpiece is so short that it can no longer be automatically feed.

4.5 SPECIAL OPERATION :

- (1) While you are cutting a workpiece, if the saw blade suddenly jams in the workpiece, depress the FRAME RAISE button to lift the saw frame immediately.
- (2) The saw blade jamming in the workpiece is most likely because of :
 - a. Slippage occurring between saw blade and drive wheel. Tension placed on the saw blade is not sufficient.
 - b. Slippage occurring between drive belt and motor pulley. Tension on drive belt is not sufficient or belt is worn.
 - c. Broken teeth on saw blade.
 - d. Too blunt saw blade.
 - e. Too fine tooth spacing on saw blade for material being cut.
 - f. Too fast feed rate for material being cut and blade used.

4.6 BREAK-IN OPERATION:

When a new blade is used , be sure to first break in the blade before using it for extended operation. Failure to break in the blade will shorten the service life of the blade ,and result in less than optimum efficiency. To break in the blade ,proceed as follow :

- (1) Reduce the blade speed setting to one half of its normal setting .
- (2) Lengthen the time required for cutting to 2-3 times that of normal.
- (3) The break-in operation can be considered sufficient if all unusual noises or metallic sounds have been eliminated. (For instance, to completely break in the blade, a minimum of five complete cuts of a 200mm (8 ins) diameter work- piece will be required.)
- (4) After the break-in operation has been completed, return the blade speed and feed rate to their normal setting.

ADDITION 1:

Amplifying Valve (Optional)

(1.) The outlines and hydraulic circuits:

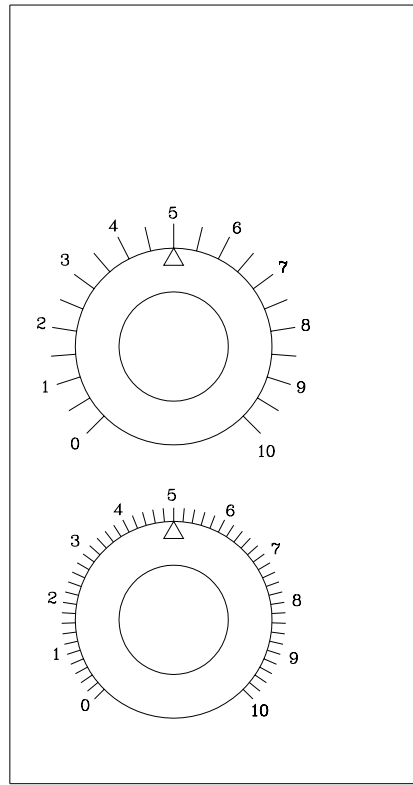

A. V.

Path: F:\DWG\H550A\PNC-10.DWG.1

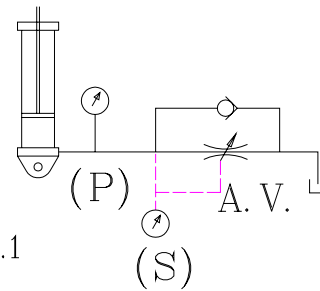
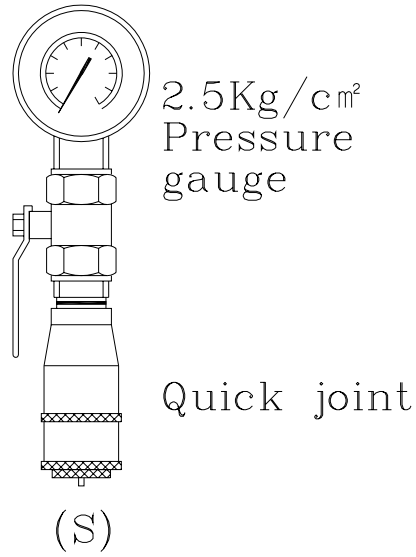

(2.) SET-UP

A. The hydraulic pressure indicated in line <p> should be kept in constant during the whole stroke of the lifting cylinder, i.e. Between the very top and bottom position of the swinging saw frame. we use springs <r> inside of lifting cylinder to balance/compensate the pressure changes (pressure varies due to saw frame swinging up and down) in line <p>. above procedures have been done in our factory before machine dispatched , now for checking test, please dry run the machine by raising the saw frame to the very top position and push the saw blade drive button, and having the quick approach rod lifted (limit switch un-touched), then check the hydraulic pressure in line <p> by reading

the pressure gauge at line <p> to see if the pressure readings keep the same during the whole stroke. (maximum 1 kg/sq.cm varies allowed) the pressure reading should be as follows:

- 8 KG/SQ.CM250/300 MODELS
- 10 KG/SQ.CM360/400/450 MODELS

B. Re-zeroing knob "a" & "b" on the amplifying valve:

For zeroing knob "a", there is a hydraulic pressure gauge as drawing <S> needed, Please plug it onto the outlet on the amplifying valve.

Pressure read at line <p> as the primary pressure.....pressure <p>

Pressure read at amplifying valve as the secondary pressure.. pressure <s>

The primary pressure should be kept the same reading, and the secondary pressure can be adjusted by turning knob "b" for cutting pressure settings zeroing knob "a" :

Dry run the machine as stated in above paragraph,

Turn knob "b" while reading pressure <s>, If there is any pressure can be read, then turn knob "a" While watching saw frame, if the saw frame shall stand still there without coming down, then there is the zero position of the knob "a" (zero feed-rate), check the " 0 " mark on the knob "a" to see if this mark pointing to "0" position. If not, loosen set screw and zeroing it (Please make sure tighten the set screw after zeroing). zeroing knob "b" :

After zeroing knob "a", turn knob "a" at "5" position, and let the machine running in the same condition as previous did - dry running. turn knob "b" while reading pressure <s>, If the pressure reach 5.5 to 6 kg /sq.cm, then loosen the set screw on the knob "b" and have the " 5 " mark pointing to "5" position and tighten the set screw.

(3.) OPERATION

Knob "a" is for maximum feed-rate setting:

The smaller the diameter of the material being cut, the higher feed-rate.

The softer the material being cut, the higher feed-rate can be set. And vice-versa.

Knob "b" is for cutting pressure setting:

The tougher the material being cut, the higher cutting pressure needed. For instance, when cutting thin pipes/tubes, mild carbon steels, Only little pressure needed, and for stainless/high alloy tool steels or inconel special steels, high cutting pressure should be needed. There are both AISI/JIS material codes shown on the control panel, Please refer to it for proper cutting pressure setting.

LIMITATION: The sum of the number set on knob "a" and "b" can not exceed 10.

5. Maintenance

5.1 HYDRAULIC CIRCUIT

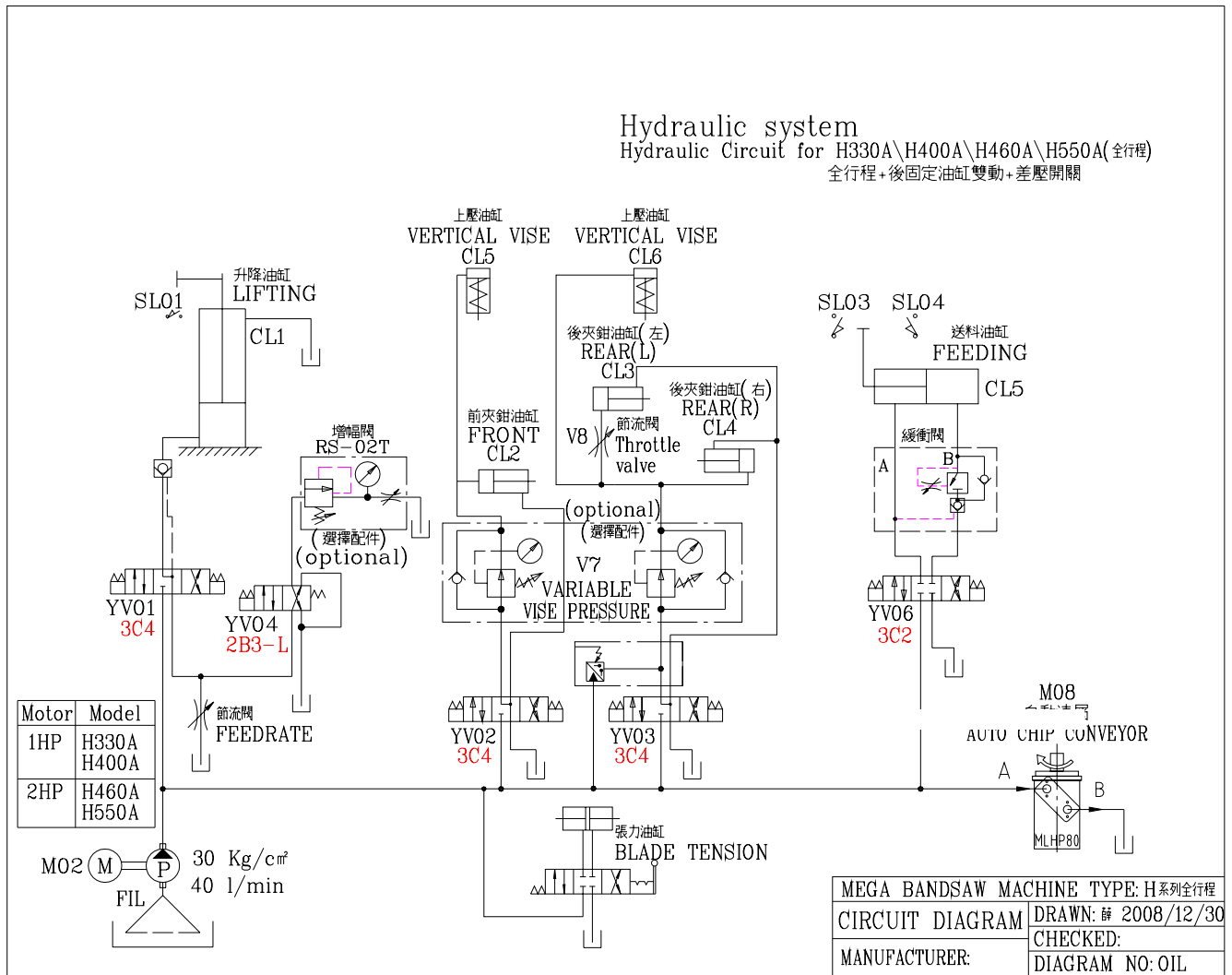

5.2 Oiling and Lubricant

The operator should be responsible for the proper lubrication of the machine. The grade and quality of lubricant are given in the lubrication chart below :

Oil Lubrication chart

	Lubricating Point	Lubricant	Quantity	Oiling Frequency
1.	Blade Tension Device	DAPHNE FLUID 32T	Few	Twice a year
2.	Drive Wheel Bearing	Grease	Few	Thrice a year
3.	Guide Slides	Shell Tonna 33	Few	Oil daily
4.	Transmission Gear Box	DAPHNE GEAR LUBE 320	Few	Twice a year
5.	Cutting Fluid Tank	Cutting Oil Mixture (KH ULTRA COOL EX-2)	82 liter	Daily
6.	Hydraulic Oil Tank	DAPHNE FLUID 32T	44 liter	Twice a year

Belt Size			
	Belt Name	Belt Size	Quantity
7	Motor Belt	50HZ use 3V475 & 60HZ use 3V450 Inverter use 3V450	1
8	Wire Brush Belt	M42	1

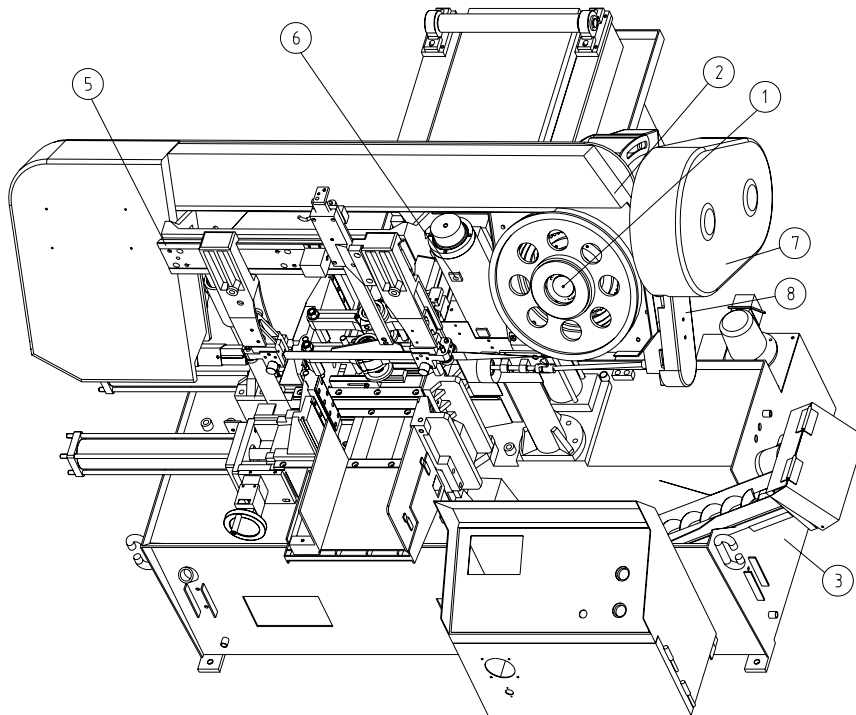

F:\Dwg\H330A\H330A-1501A_3.DWG

5.3 OTHERS

VARIABLES WHICH AFFECT BANDSAW BLADE LIFE

1. The Operator - The operator is the most important variable at any test. He can make or break any test and often has a great deal of influence over whose bandsaw blades are used. He can also be a good source of information on what is going on, competitive situations, relationships with manufacturers or distributors, etc. Don't ignore the operator.
2. Number of Teeth in the Band - There should always be a minimum of three teeth in the work at all times to avoid straddling. Nine to twelve is the optimum number and anything over 24 is probably too high (although sometimes unavoidable).
3. Tooth Style - Standard, skip, sabre, Si -Pitch or XL.
The best tooth style for the material being cut should be used.
4. Tooth Set - Regular, Wavy, E.T.S., Si - Pitch, Maxi -Sharp. The proper band with the proper set for the material being cut should be used.
5. Band Tension - Band tension, as measured by Simonds Patented Simometer, is important to the efficient running of a bandsaw blade. Too little tension can cause a blade to "wander" in the cut while too much can actually pull the band apart.
6. Band Speed - Start with Simonds speed and feed slide chart. Too high a speed can cause too much heat lessening the life of the band. Too low a speed could cause overfeeding. Always reduce the speed when cutting dry.
7. Break - in Procedure - The normal feed rate should be reduced to about 1/2 for the first 50 square inches or so to hone in the blade. A good example is that of a sharp pencil. You must not bear down hard on it right away or you risk breaking the point. The same holds true for a bandsaw tooth.
8. Feed Rate - Set the feed rate by square inches per minute according to simonds speed and feed slide chart. Watch your chips and adjust accordingly as both overfeeding and underfeeding cut bandsaw life.
9. Band Quality - Carbon steel blades vs. High Speed Blades, M-2 vs. M42, etc. All affect the life you will get from the band. Once again choose the proper type band for the job. There are also differences in quality among manufacturers. Simonds has some of the highest quality standards in the world.
10. Machine Type - Different makes and models with varying horsepower available can affect life. A well made heavy duty machine can greatly enhance band life.
11. Wheels - The Wheels carry the band and it is very important that they be properly aligned and that the bearings be in good shape. Misaligned wheels and loose bearings can cause undue stresses on the band and reduce fatigue life. Flanges should also be checked and if extremely worn, the wheel should be replaced. Worn flanges are usually a sign of misalignment or bad bearings.

12. Machine Condition-Whether a machine is old or new, and whether well maintained or not contributes to how well it runs and how long the band last. The better shape a machine is in, the better the bands will run. Poor machines ruin bandsaw blades.
13. Proper Vises - The work must be properly held. Side vises and top vises, if necessary, should be in good shape and able to firmly hold the work. Anything that moves will strip teeth.
14. Guides - The guides must support the band well while in the cut. The guides in conjunction with tension are all that keeps the band straight. Roller guides should be snug against the band and turn freely.

The surface should be flat and not worn at an angle. Solid carbide guides should also be snug against the band and should show no sign of wear. They can be faced off if necessary. Backup guides should not be grooved and should also turn freely if rollers. Be sure the teeth of the band do not ride up into the guides.
15. Guide Arms - The guide arms should be as close to the work as possible. Beam strength is determined by a cubed factor, so increasing the distance between the guides by a factor of 2 decreases the beam strength by a factor of $(2)^3$ or 8. You lose a lot very quickly.
16. Brushes - A good set of brushes (powered is preferable) aid in the cleaning of chips from the gullets, if available and properly adjusted. One test shows a better than 25 % increase in life just by using brushes.

Always check the brushes.
17. Coolant - A good coolant will help cool, lubricate and wash the bandsaw blades. Always maintain a good flood of coolant when possible.
18. Material machinability - The tougher the material, the less expected band life. For instance 1018 vs. Inconel 718.
19. Material Hardness - A Rockwell C scale reading of 40 is approaching a machinability of 0. Only recently have we been able to go much beyond this with the introduction of our CT Type III band.
20. Material Shape - Structural and small solids are always harder on a band than large solids.
21. Production Requirement - Continuous runs of one size and material is easier than intermittent cutting of various sizes, shapes and materials.
22. Room Temperature - Temperature has a big effect on the hydraulic system of a machine. Always allow the machine to warm up before starting to saw.

6. TROUBLE SHOOTING GUIDE

The following charts contains some typical troubles along with the probable causes and remedies for each.

6.1 Sawing Problems and Solution

<input type="radio"/>	<input type="radio"/>	<input type="radio"/>	<input type="radio"/>	<input type="radio"/>	Use of blade with incorrect pitch	Use blade with correct pitch , suited to workpiece
<input type="radio"/>	<input type="radio"/>	<input type="radio"/>	<input type="radio"/>	<input type="radio"/>	Failure to break-in saw blade	Perform break-in operation
<input type="radio"/>	<input type="radio"/>	<input type="radio"/>			Excessive saw blade speed	Reduce speed
			<input type="radio"/>	<input type="radio"/>	Insufficient saw blade speed	Increase speed
<input type="radio"/>		<input type="radio"/>	<input type="radio"/>	<input type="radio"/>	Excessive load	Reduce feed rate
<input type="radio"/>		<input type="radio"/>	<input type="radio"/>		Insufficient load	Increase feed rate
		<input type="radio"/>	<input type="radio"/>		Insufficient saw blade tension	Increase tension
<input type="radio"/>		<input type="radio"/>	<input type="radio"/>	<input type="radio"/>	Wire brush not working correctly	Relocate or replace
<input type="radio"/>		<input type="radio"/>	<input type="radio"/>		Blade improperly guided by insert	Check and correct
<input type="radio"/>	<input type="radio"/>	<input type="radio"/>	<input type="radio"/>	<input type="radio"/>	Improperly clamped workpiece	Check and correct
	<input type="radio"/>	<input type="radio"/>	<input type="radio"/>		Excessively hard material surface	Soften material surface
		<input type="radio"/>	<input type="radio"/>	<input type="radio"/>	Excessive cutting rate	Reduce cutting rate
	<input type="radio"/>	<input type="radio"/>			Non-annealed workpiece	Replace with suitable workpiece
<input type="radio"/>		<input type="radio"/>	<input type="radio"/>	<input type="radio"/>	Insufficient or lean cutting fluid	Add fluid or replace
<input type="radio"/>		<input type="radio"/>	<input type="radio"/>	<input type="radio"/>	Vibration near machine	Relocate machine
		<input type="radio"/>	<input type="radio"/>		Non-water soluble cutting fluid used	Replace
<input type="radio"/>		<input type="radio"/>	<input type="radio"/>		Air in lift cylinder	Bleed air
		<input type="radio"/>		<input type="radio"/>	Broken back-up roller	Replace
<input type="radio"/>	<input type="radio"/>	<input type="radio"/>	<input type="radio"/>	<input type="radio"/>	Use of non-specified saw blade	Replace
<input type="radio"/>	<input type="radio"/>	<input type="radio"/>	<input type="radio"/>	<input type="radio"/>	Fluctuation of line voltage	Stabilize
<input type="radio"/>		<input type="radio"/>	<input type="radio"/>		Adjustable blade guide arm too far from workpiece	Bring blade guide arm close to workpiece
		<input type="radio"/>	<input type="radio"/>	<input type="radio"/>	Loose blade guide	Tighten
		<input type="radio"/>		<input type="radio"/>	Blue or purple saw chips	Reduce cutting rate
<input type="radio"/>		<input type="radio"/>		<input type="radio"/>	Accumulation of chips at inserts	Clean
		<input type="radio"/>			Reverse positioning of blade on machine	Re-install
<input type="radio"/>		<input type="radio"/>	<input type="radio"/>		Workpiece not bundled properly	Re-bundle
<input type="radio"/>		<input type="radio"/>		<input type="radio"/>	Back edge of blade too hard against flange	Adjust wheel so that blade is just firmly against flange
<input type="radio"/>	<input type="radio"/>	<input type="radio"/>			Workpiece of insufficient dia.	Use other machine, suited for diameter of workpiece
	<input type="radio"/>	<input type="radio"/>	<input type="radio"/>		Saw blade teeth worn	Replace

6.2 Minor Operating Troubles and Remedies

Symptom	Probable Cause	Remedy
1. Buttons do not function	(1) Power disconnected (2) Circuit protector OFF (3) Thermal relay activated (4) Safety interlocks that is a. No workpiece is clamped in the vice. b. The saw frame is not fully raised to the height preset. c. The saw frame is raised too high so that the upper limit switch has been touched	(1) Connect (2) Turn on (3) Push reset button a. Load workpiece b. Depress FRAME RAISE button c. Depress QUICK APPROACH switch
2. The saw frame descends out of sequence	(1) Solenoid valve blocked. (2) Piping leakage (3) Packings , O-Rings of cylinder worn or torn	(1) Disassemble the valve and clean thoroughly. (2) Inspect hydraulic piping (3) Replace
3. Short service life of wire brush	(1) Wire brush too heavily in contact with saw blade.	(1) Re-position the wire brush.
4. Bubbles out of fluid taps	(1) The cutting fluid is not sufficient (2) The filter clogged by swarf	(1) fill up take. (2) Clean the tank and filter.

6.3. Error information

The following table contains some typical errors along with the error details and remedies.

AH257_ Bandsaws Trouble shooting guide

Code	Error name 異常名稱	Remedy	排除方法
00	正常停機 Machine stops normally	1.Press Blade-ascending button	按鋸帶上升按鈕
01	上升電磁閥異常 Solenoid - ascending frame abnormal	1.Eliminate breakdown 2.Press Blade-ascending button	1.排除故障原因 2.按鋸帶上升按鈕
02	下限開關異常 Lower limit switch – descending frame abnormal	1.Eliminate breakdown 2.Press Blade-ascending button	1.排除故障原因 2.按鋸帶上升按鈕
03	前後限卡死異常 Front/rear limit switch – bar feeding saddle abnormal	1.Eliminate breakdown 2.Press Blade-ascending button	1.排除故障原因 2.按鋸帶上升按鈕
04	前進電磁閥異常 Solenoid – feeding forward abnormal	1.Eliminate breakdown 2.Press Blade-ascending button	1.排除故障原因 2.按鋸帶上升按鈕
05	無料異常 No material switch abnormal	1.Eliminate breakdown 2.Press Blade-ascending button	1.排除故障原因 2.按鋸帶上升按鈕
06	快速下降碰到下限開關異常 Saw frame touches fast to lower limit switch abnormal	1.Eliminate breakdown 2.Press Blade-ascending button	1.排除故障原因 2.按鋸帶上升按鈕
07	鋸帶近接開關異常 Sensor – switch abnormal	1.Eliminate breakdown 2.Press Blade-ascending button	1.排除故障原因 2.按鋸帶上升按鈕
10	上限開關異常 Upper limit switch abnormal	1.Eliminate breakdown 2.Press Blade-ascending button	1.排除故障原因 2.按鋸帶上升按鈕
11	前極限開關異常 Front limit switch abnormal	1.Eliminate breakdown 2.Press Blade-ascending button	1.排除故障原因 2.按鋸帶上升按鈕
12	後退電磁閥異常 Feed-backward solenoid abnormal	1.Eliminate breakdown 2.Press Blade-ascending button	1.排除故障原因 2.按鋸帶上升按鈕
13	後極限開關異常 Rear limit switch abnormal	1.Eliminate breakdown 2.Press Blade-ascending button	1.排除故障原因 2.按鋸帶上升按鈕
14	變頻器出現異常 Inverter abnormal	1.Eliminate breakdown 2.Press Blade-ascending button	1.排除故障原因 2.按鋸帶上升按鈕
15	變頻器故障 Inverter-breakdown	1.Eliminate breakdown 2.Press Blade-ascending button	1.排除故障原因 2.按鋸帶上升按鈕
16			
17	油壓馬達過負載 OR 水泵馬達過負載 Hyd. Motor overload or coolant pump overload	1.Eliminate breakdown 2.Press Blade-ascending button	1.排除故障原因 2.按鋸帶上升按鈕

異常編號	異常名稱	<i>Remedy</i>	排除方法
20			
21			
22	鋸帶啓動按鈕卡死異常 Starting blade button jammed	1.Eliminate breakdown 2.Press Blade-ascending button	1.排除故障原因 2.按鋸帶上升按鈕
23	鋸帶下降按鈕卡死異常 Descending blade button jammed	1.Eliminate breakdown 2.Press Blade-ascending button	1.排除故障原因 2.按鋸帶上升按鈕
24	送料架前進按鈕卡死異常 Feed-forward button jammed	1.Eliminate breakdown 2.Press Blade-ascending button	1.排除故障原因 2.按鋸帶上升按鈕
25	送料架後退按鈕卡死異常 Feed –forward button jammed	1.Eliminate breakdown 2.Press Blade-ascending button	1.排除故障原因 2.按鋸帶上升按鈕
26	前夾鉗-開 按鈕卡死異常 Front vise opening button jammed	1.Eliminate breakdown 2.Press Blade-ascending button	1.排除故障原因 2.按鋸帶上升按鈕
27			
28			
29	自動閒置過久(5 分鐘) Auto to leave unused overlong (5 minutes)		
30	自動切削計數到達 Auto cutting piece counting over	1.Press Blade-ascending button 2.Press the key, CLEAR	1.按鋸帶上升按鈕 2.按面板 CLEAR 鍵
31	鋸帶上升按鈕卡死異常 Blade-descending button jammed	1.Eliminate breakdown 2.Press Blade-descending button	1.排除故障原因 2.按鋸帶下降按鈕
32	自動切削計數到達未歸零 Auto cutting piece counting over: don't zero	1.Press Blade-ascending button 2.Press the key, CLEAR	1.按鋸帶上升按鈕 2.按面板 CLEAR 鍵
33	鋸輪蓋,皮帶輪蓋未蓋 Wheel-cover and pulley-cover unclosed	1.Eliminate breakdown 2.Press Blade-ascending button	1.排除故障原因 2.按鋸帶上升按鈕
34	鋸帶未夾緊異常 No clamping-tight blade		
35			
36	鋸帶切削時,前夾鉗未夾緊 No clamping-tight front vise while cutting	1.Eliminate breakdown 2.Press Blade-ascending button	1.排除故障原因 2.按鋸帶上升按鈕
37			
38	鋸帶切削時,以偏移出至設定 while cutting, blade-departure from setting	1.Eliminate breakdown 2.Press Blade-ascending button	1.排除故障原因 2.按鋸帶上升按鈕

7. REFERENCE CHARTS

7.1 Standard Cutting Chart

Material JIS code	Blade Pitch TPI	Blade Speed m/min	Cutting Rate Sq c m ² /min	Service Life Sq c m ² /PCE
S20C-S50C	3M	80	50-70	42000-58000
S9CK-S15C	3M	80	42-60	38500-54000
S53C-S58C	3M	68	42-60	35000-58000
SS-50	3M	80	42-60	38500-58000
SS-41	3M	68	40-55	35000-54000
SM-50	3M	80	40-55	35000-54000
SCM-3	3M	68	45-60	31000-54000
SCR-3.4	3M	54	40-50	30000-50000
SNC-22	3M	54	35-45	28000-50000
SNC-1	3M	54	40-50	31000-50000
SNCM-22	3M	54	35-45	27000-50000
SK-4	3M	54	30-40	26000-50000
SUL-2	3M	40	25-35	26000-44000
SKS-5	3M	54	25-35	25000-42000
SKH-2	3M	27.40	25-35	19000-31000
SUH-33	3M	27.40	25-35	16000-23000
SKD-61	3M	27	15-25	15000-23000
SKD-1	3M	27	8-20	10000-20000
SUS-27	3M	27.40	8-20	10000-20000
SUS-32	3M	27.40	8-20	10000-20000

NOTE:

- (1) All conditions described above are based on the use of high speed steel saw blade.
- (2) The workpiece is 150 mm round and solid, normalized heat treatment, and there are no hard spots in the material.
- (3) The cutting surface concave or convex by 1.0mm is permitted.
- (4) The indicated service life of a saw blade stated is based on an average value spread over results from 10 saw blades.
- (5) The selection of a correct blade for any one type and size of material being sawn is largely dependent upon trial and error until the desired conditions are fulfilled, i.e. finish cutting time ,blade life, etc. However these charts are offered here for the guidance of users so that these conditions may be obtained.

7.2 Standard Cutting Chart

Material AISI code No.	Brinell hardness Bhn	Blade speed fpm	Cutting rate Sq in/min
1108-1111	150-175	220-260	9.0-12.0
1112-1118	125-150	240-270	10.0-14.0
1115-1132	140-165	220-260	9.0-12.0
1137-1151	155-180	180-200	5.0- 8.5
1212-1213	150-175	240-270	10.0-14.0
1008-1013	150-175	220-260	7.0- 9.0
1015-1035	160-175	240-270	8.0-12.0
1040-1064	160-180	180-210	6.0- 9.0
1065-1095	180-205	120-140	5.0- 6.5
1320-1330	200-220	140-180	5.0- 7.0
1335-1345	200-220	140-180	5.0- 6.5
2317-	180-190	150-190	5.0- 6.0
2330-2345	180-220	130-170	4.0- 5.0
2512-2517	200-220	120-160	3.5- 4.5
3115-3130	180-220	150-190	5.0- 7.0
3135-3150	190-230	120-160	4.5- 5.5
3310-3315	200-230	130-170	3.5- 4.5
4017-4024	170-190	180-230	4.5- 5.5
4027-4042	180-220	180-220	4.5- 5.5
4047-4068	190-210	170-200	3.5- 4.5
4130-4140	190-215	180-220	4.5- 6.0
4142-4150	200-230	130-180	3.5- 4.5
4317-4320	200-225	170-210	4.0- 5.0
4337-4340	230-250	130-180	3.5- 4.5
4608-4621	190-210	180-210	4.0- 5.0
4640	190-230	130-170	3.5- 4.5
4812-4820	220-240	130-170	3.0- 4.0
5045-5046	170-190	180-220	4.0- 5.5
5120-5135	180-200	150-190	4.0- 5.0
5140-5160	200-220	160-200	4.0- 5.0
50100-52100	210-230	80-110	3.0- 4.0
6117-6120	180-210	130-170	4.0- 5.0
6145-6152	180-210	130-170	3.5- 4.5
8615-8627	160-190	130-180	3.5- 4.5
8630-8645	190-220	130-180	3.5- 4.5
8647-8660	190-220	120-160	3.0- 4.0
8715-8750	180-215	140-180	3.5- 4.5
9255-9260	150-180	120-160	2.5- 3.5
9261-9262	200-230	110-150	1.5- 2.5
9310-9317	210-240	110-150	1.5- 2.5
9437-9445	175-200	150-190	3.5-4.5
9747-9763	180-220	130-180	2.5-3.5
9840-9850	210-250	130-180	3.5-4.5

7.3 Standard Cutting Chart

Material AISI code No.	Brinell hardness Bhn	blade speed fpm	Cutting rate sq in/min.
Stainless Steels			
302,304	130-170	80-90	2-3
303,303F	150-200	90-100	3-4
308,309,310	160-220	60-80	1-2
314,317,330	160-220	50-80	1-2
316,420	160-220	70-80	2-3
321,347	165-200	90-100	2-3
410,420F	140-185	100-110	2-3
416,430F	155-195	140-150	4-6
430,446	170-215	60-80	2-3
440,A,B,C,	160-190	70-80	2-3
440F,443	175-215	90-100	2-3
High-speed Tool Steels			
T-1,T-2	217-248	80-90	2.0-3.0
T-4,T-5	235-255	75-85	1.0-2.0
T-6,T-8	220-293	60-80	1.0-2.0
T-15	228-255	50-80	1.0-2.0
M-1	217-228	100-120	3.0-4.0
M-2,M-3	217-241	75-85	2.0-3.0
M-10	217-228	60-80	1.0-2.0
Tool Steel (Air, Oil, And Water Hardening)			
A-2	217-241	140-170	2.0-3.0
D-2,D-3	217-241	75-85	2.0-3.0
D-7	228-255	60-80	1.0-2.0
O-1,O-2	187-207	140-170	4.0-5.0
O-6	207-228	140-160	5.0-6.0
W-1 special	156-187	170-190	3.0-4.0
W-1 extra	156-196	170-190	3.0-4.0
W-1 regular	156-196	170-190	3.0-4.0
H-12,H-13,H-21	205-228	140-160	3.0-4.0
H-22,H-24	217-241	100-120	2.0-3.0
S-1	177-212	150-170	3.0-4.0
S-2,S-5	173-228	80-100	2.0-3.0
L-6	190-230	150-170	4.0-5.0
L-7	180-230	110-130	3.0-4.0

NOTE:

- (1) All conditions described above in chart 2 and 3 are based on the use of Electron Weld Bimetal Blade. 4/3 T.P.I.
- (2) The workpiece is 6 inch round and solid ,normalized heat treatment ,and there are no hard spots in the material.
- (3) The cutting surface concave or convex by 1.0mm is permitted.
- (4) For production Band and Super Electron Weld ,speed may usually be increase up to 10 % .
- (5) Decrease speeds by 50 % for NEO_TYPE and CARBON Bands.
- (6) As a guide that "The larger workpiece (compare to the 6 inch),the slower blade speed."