

MODEL HLY-5000X

BAR MOUNT SPEEDOMETER/TACHOMETER INFORMATION SYSTEM

Dakota Digital

3421 W. Hovland Ave., Sioux Falls, SD 57107
Phone: (605) 332-6513 FAX: (605) 339-4106
www.dakotadigital.com

Please read this before beginning installation or wiring.

POWER

Connect the red wire from the main harness to accessory power from the ignition switch.

A good quality, solid state ignition switch should be used. The contacts on a mechanical "bar" switch can bounce due to the vibration and cause the system to momentarily lose power and reset itself.

Never connect this to a battery charger alone. It needs to have a 12 volt battery connected to it. Battery chargers have an unregulated voltage output that will cause the system to not operate properly.

GROUND

The black wire is the main ground for display system. This should be connected directly to the negative cable on the battery. Connecting to a tank or frame ground can cause a weak or intermittent ground connection. A poor ground connection can cause improper or erratic operation.

SPEEDOMETER

The speed input connector plugs into the speed sensor to tell how fast you are traveling. On cable driven applications, the external sensor connects to the speedometer cable and provides the electric signal. The sensor has a 5/8" coarse thread fitting that accepts mid-80's and earlier cables directly. For newer cycles the speedometer cable will need to be replaced with one having the correct fitting.

With transmissions having the built-in electric sensor, a three-wire harness adapter connects the transmission speed sensor to the speedometer. This system will also accept most after-market inductive, Hall-effect, or ground switch sensors.

The speedometer is fully adjustable and calibration is listed below.

SPEEDOMETER CALIBRATION

The speedometer calibration is done using the function (trip) switch. The speedometer can be calibrated two different ways. The first method is to place the unit in auto-cal mode and drive exactly one mile (one km for metric). The second method is to place the unit in adjust mode and the speed reading can be moved up or down while driving.

METHOD 1, AUTOCAL

1. Make sure the key is off so the gauge is not powered.
2. Press and hold the function switch.
3. Turn the key on. With the switch still held, start the bike. The display will show "--".
4. Release the function switch. The display will switch between "AUtO" (auto cal), "AdJ" (adjust), "CYL" (cylinder select), and "SEt" (shift bar).
5. When "AUtO" is displayed press the function switch. This will place the unit in auto calibration mode.
6. Release the function switch. The speedometer will show "-00.0".
7. Drive exactly one mile (or 1km). The speedometer display will increase as signal pulses are received from the speed sensor.
8. Press and release the function switch. The calibration value will be calculated and stored. The gauge will now restart in normal mode with the new speed calibration.

METHOD 2, ADJUST SPEED

1. Make sure the key is off so the gauge is not powered.
2. Press and hold the function switch.
3. Turn the key on. With the switch still held, start the bike. The display will show "--".
4. Release the function switch. The display will switch between "AUtO" (auto cal), "AdJ" (adjust), "CYL" (cylinder select), and "SEt" (shift bar).
5. When "AdJ" is displayed press the function switch. This will place the unit in calibration adjustment mode.
6. Release the function switch. The speed display will flash to indicate that it is in the adjust mode. The tachometer will operate normally.
7. Drive at a known speed. Following another vehicle that is driving at a constant, known speed can do this.
8. Press the function switch. The speed reading will begin increasing until the function switch is released. The next time the function switch is pressed, the speed reading will begin decreasing until it is released.
9. Once the speedometer is reading correct release the function switch. The new calibration will be saved if no adjustments are made for 7-10 seconds.

TACHOMETER

The tachometer is used by connecting the green wire from the main power harness to the negative side of the coil or to an ignition module tach output. The tachometer is adjustable for 1, 2, 4, 6, or 8 cylinder settings. The 1 cylinder setting is used for single-fire ignition systems without a buffered tach output.

The following instructions are used to set the tachometer calibration:

1. Make sure the key is off so the gauge is not powered.
2. Press and hold the function switch.
3. Turn the key on. The display will show "--".
4. Release the function switch. The display will switch between "AUtO" (auto cal), "AdJ" (adjust), "CYL" (cylinder select), and "SEt" (shift bar).
5. When "CYL" is displayed press the function switch. This will place the unit in the tach calibration mode.
6. Release the function switch. The display will switch between "1CYL", "2CYL", "4CYL", "6CYL", and "8CYL".
7. When the desired setting is displayed press the function switch. The display will show "tACH".
8. Release the function switch. The system will now start up normally with the new setting.

TACHOMETER RED LINE/SHIFT INDICATOR

A single bar will light up to indicate a shift point or red line. The rpm where the bar lights up is user selectable and can be turned off completely if desired. The bar is factory set to about 5000 rpm.

The following instructions are used to set the tachometer warning bar:

1. Make sure the key is off so the gauge is not powered.
2. Press and hold the function switch.
3. Turn the key on. The display will show "--".
4. Release the function switch. The display will switch between "AUtO" (auto cal), "AdJ" (adjust), "CYL" (cylinder select), and "SEt" (shift bar).
5. When "SEt" is displayed press the function switch. This will place the unit in the shift/red line set mode.
6. Release the function switch. The bar display will start at 2 and begin moving up. After it reaches the top it will go out and then start back at 2.
7. When the desired rpm setting is displayed press the function switch. To disable this feature, press the function switch while the bar is not displayed. The display will show "tACH" once the new setting is stored.
8. Release the function switch. The system will now start up normally with the new setting.

TRIP ODOMETER

The trip odometer is activated by the push button function switch located on the back, left side of the unit. Pressing and releasing the button will toggle the display from the trip mileage to the standard speedometer reading or from the speedometer to the trip odometer. Pressing and holding the button while the trip odometer is displayed will reset the trip odometer. The trip odometer will read from 0 to 999.9 miles. While the trip mileage is displayed the unit will occasionally flash "trIP" to indicate it is in trip odometer display mode.

ODOMETER

The trip odometer is activated by the push button function switch located on the back, left side of the unit. Pressing and holding the button while the speed is displayed will cause the unit to read out the odometer mileage. The odometer will read from 0 to 99,999 miles. The speed display will first show "odo", then the thousands of miles, then the hundreds of miles.

For example, 34,792 miles would be displayed as "odo", " 34", " 792", " " and then return to the speedometer reading.

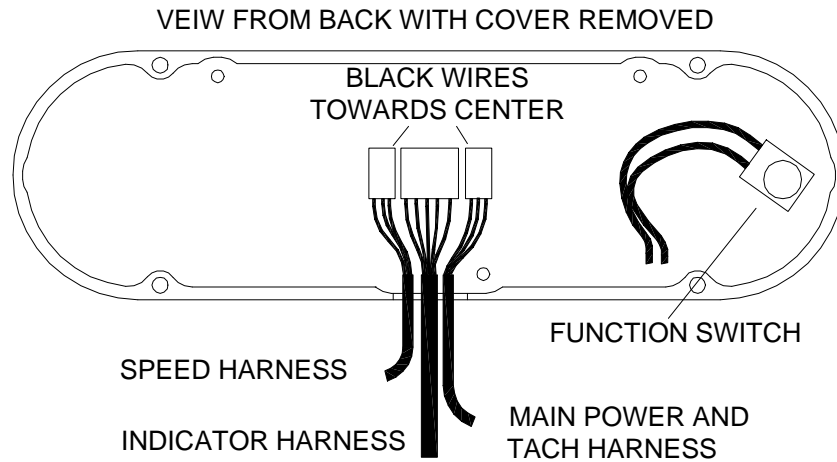

NEUTRAL INDICATOR

The neutral indicator is activated by a ground connection to the white wire on the 5-wire indicator harness. This will interface with the stock neutral switch on the transmission.

The neutral indicator appears as a pair of vertical bars that flash on the left side of the speed display. The neutral indicator is disabled in trip display, odometer display, and speed cal modes.

LOW OIL PRESSURE INDICATOR

The low oil pressure indicator is activated by a ground connection to the brown wire on the 5-wire indicator harness. This will interface with the stock oil pressure switch on the engine.

When there is a ground to the brown wire the speed display will flash "LO", "OIL". Pressing the push button function switch will toggle between the speed, trip, and lo oil displays. The low oil indicator is disabled in speed cal modes.

TURN SIGNAL AND HIGH BEAM INDICATORS

The right turn, left turn, and high beam indicators are activated by 12 volts at their respective hook-up wires on the 5-wire indicator harness (not the 3-wire harness). The right turn signal wire is green, the left turn signal wire is black, and the high beam wire is red. These can be connected to the same wires that the indicator lights are connected to. The display system wire colors may not match the wire colors in your electrical wire harness. The turn and high beam indicators are disabled in low oil display, trip display, odometer display, and speed cal modes. This system does **not** have a wire for automatic turn signal canceling modules.

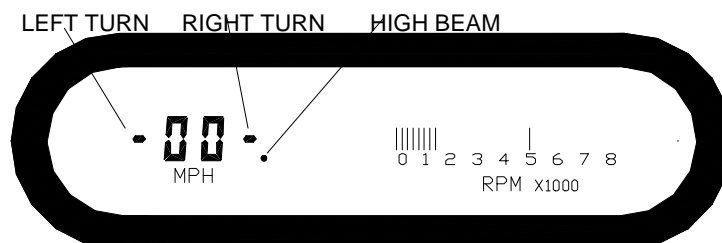
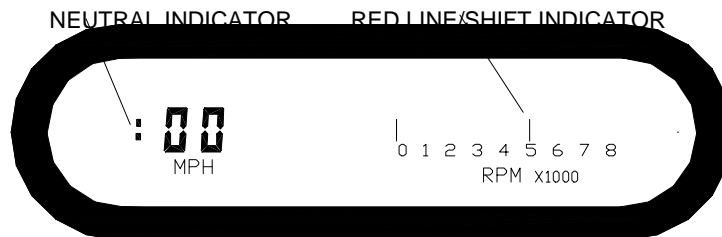

WIRING

In order to ensure that there are no problems with voltage drops causing the system to shut down, a heavy duty, solid state ignition switch is recommended. Also, the black wire should be connected directly to the negative battery terminal to avoid erratic operation due to a poor ground connection.

The wire color code for the 3-wire main display system harness is as follows:

RED	+12 volt with key on
BLACK	ground (connect directly to battery)
GREEN	tachometer signal

The wire color code for the 5-wire indicator harness is as follows:

RED	High Beam indicator
BLACK	Left Turn indicator
GREEN	Right Turn indicator
WHITE	Neutral indicator
BROWN	Low Oil Pressure indicator

Speedometer connection varies depending on the year and model of the cycle. Using different speed adapter kits the speedometer can read a speedometer cable, a stock electric transmission speed sensor, or an aftermarket gear-tooth sensor. Each adapter kit connects to the speedometer using the three pin connector on the back of the system, underneath the back plate.

SEN-5011: The cable adapter accepts a 5/8" thread fitting and can be mounted in a concealed location. Cycles that have a metric-threaded speedometer cable will need to have the cable modified or replaced.

SEN-5012: The adapter harness for using a stock transmission speed sensor converts the triangular connector to the in-line connector on the speed/tach system.

SEN-5019: The gear-tooth sensor kit consists of a two-terminal sensor and a harness to connect it to the speed/tach system. The sensor needs to be mounted within 1/8" of the teeth on a steel final drive gear.

WARRANTY

All DAKOTA DIGITAL instruments are warranted free of defects in material and workmanship for 3 years from the date of purchase. In the event of a problem with one of our products within the warranty period, DAKOTA DIGITAL will replace or repair the instrument at no charge. (The decision to repair or replace is solely that of DAKOTA DIGITAL. DAKOTA DIGITAL is not responsible for shipping costs of products returned under warranty or for labor charges for product installation and removal.) This warranty becomes invalid if the product is misused, altered or installed incorrectly.

For warranty coverage, you must first call to receive an RMA#. Ship the product transportation prepaid via UPS or insured Parcel Post. A copy of the original invoice or dated bill of sale along with a description of the defect is also required. Make sure that the RMA number is clearly visible on the outside of the package as well as inside on the paper work.

The above warranties, both expressed and implied, do not cover damages caused by improper installation, misuse, abuse, fire, unauthorized modifications, floods or acts of God, or reimbursement of customer or shop time. The extent of the warranty is limited only to the product and does not cover any loss or damage to vehicle, equipment, or non-DAKOTA DIGITAL products.

SERVICE AND REPAIR

DAKOTA DIGITAL offers complete service and repair of its product line. In addition, technical consultation is available to help you work through any questions or problems you may be having installing one of our units.

Should you ever need to send the unit back for repairs, please package the product in a good quality box along with plenty of packing material. Ship the product by UPS or insured Parcel Post. Be sure to include your RMA#, a complete description of the problem, your full name and address (street address preferred), and a telephone number where you can be reached during the day. **A return authorization number (RMA#) for products being return for repair is required.** Do not send any money. We will bill you for the repair charges.

Dakota Digital

3421 W. Hovland Ave., Sioux Falls, SD 57107
Phone: (605) 332-6513 FAX: (605) 339-4106
www.dakotadigital.com