

---

# Truck Camper Owner's Manual



# TABLE OF CONTENTS

<b>Introduction</b> .....	<b>1</b>
Information in This Manual .....	1
Dealer's Responsibility .....	1
<b>Prolonged Occupancy</b> .....	<b>2</b>
<b>Limited Warranty</b> .....	<b>2</b>
Important Information About Your Warranty .....	2
Exclusions .....	3
<b>Identification</b> .....	<b>4</b>
<b>Centre Of Gravity</b> .....	<b>5</b>
Weight Information .....	6
<b>Propane Systems</b> .....	<b>6</b>
LP Gas Safety Precautions .....	7
Filling LP Gas Tanks .....	7
Lighting LP Gas Appliances .....	8
If You Smell Gas .....	8
Using LP Gas Systems at Low Temperatures .....	8
<b>Fire And Safety</b> .....	<b>9</b>
LPG Leak Detector .....	9
Smoke Detector .....	9
Carbon Monoxide .....	9
<b>Electrical System</b> .....	<b>10</b>
Ground Fault Interrupter .....	10
Systems Monitor Panel .....	10
Water Pump Control Switch .....	11
Monitor Panel-Levels Indicators Switch .....	11
<b>Water System</b> .....	<b>11</b>
Fresh Water Tank .....	11
City Water Hookup .....	12
<b>Waste Water System</b> .....	<b>12</b>
<b>Loading Your Camper Onto Your Pickup</b> .....	<b>13</b>
Loading the camper .....	13
Tie-downs or Turnbuckles .....	13
Electrical Connection to your truck .....	13
Towing and Hitch systems .....	14
Loading Cargo .....	14
Carrying Capacity .....	14
<b>Unloading Your Camper</b> .....	<b>15</b>
Operating Remote Control Electric Jacks .....	16
Dually Brackets .....	17
<b>Camper Features</b> .....	<b>17</b>
Vents .....	17
Lighting .....	17
Bathroom .....	17
Dinette Bed .....	17
Ladder and Roof Rack .....	18
Cab-Over .....	18

# TABLE OF CONTENTS

Storage .....	18
<b>Appliances.....</b>	<b>18</b>
Lighting LP Gas Appliances .....	18
Microwave Oven .....	18
Refrigerator .....	18
Water Heater .....	18
Range / Oven .....	19
<b>Opening The Slide Out.....</b>	<b>19</b>
Opening & Closing The Slide.....	20
Slide Out Failure .....	20
Operating The Full Wall Slide .....	20
<b>Tent Models.....</b>	<b>21</b>
Tent Care & Maintenance .....	21
<b>Maintenance.....</b>	<b>22</b>
Maintaining Exterior And Interior Finishes.....	22
<b>Winterization And Winter Storage .....</b>	<b>23</b>
Winterizing Your Camper .....	24
Preparing Your Unit For Storage .....	25
Short-Term Storage Above Freezing (Less Than 60 Days).....	26
Long-Term Storage Above Freezing.....	26
General Camper Winter Storage Checklist.....	27
Reactivating the Unit After Storage .....	27
<b>Travel Tips.....</b>	<b>29</b>
Some Useful Equipment to Take Along .....	29
<b>Troubleshooting .....</b>	<b>30</b>
FAQ .....	30
<b>Notes.....</b>	<b>31</b>

---

## **INTRODUCTION**

ADVENTURER LP LIMITED PARTNERSHIP would like to take this opportunity to thank you for choosing one of our truck campers. We have sought to anticipate your needs and desires with respect to convenience, style, safety and engineering. Customer satisfaction and goodwill are of primary importance, so we have provided this manual to assist you in understanding the proper use, operation and maintenance of the various components and systems that have been designed into your truck camper.

Study this manual carefully, as well as the manuals included from the manufacturers for the appliances and equipment installed in your unit. Your Dealer will take you through the unit and explain how each of the systems is operated, making sure you understand it fully before you set out on the road.

Product improvement is a continuing process at Adventurer LP Ltd., thus we reserve the right to change materials, components and specifications without prior notice.

In the interest of safety, your recreational vehicle has been designed and constructed to meet or exceed the requirements of applicable Recreational Vehicle Industry Association & ANSI codes.

A warranty registration card is enclosed along with the manual. Please complete and fill out this registration card with your Dealer, and return it to us within fifteen (15) days of purchase in order to validate the warranty.

Should you have additional questions or problems regarding operation, maintenance, service or warranty, please contact your Dealer for assistance.

This manual has been designed to cover our complete line of Truck Campers.

### ***Information in This Manual***

Products and components in Adventurer Camper's may change without notice. This manual is intended to be a guide only. Please refer to the individual component instructions and warranties in your Info-Pak.

### ***Dealer's Responsibility***

Adventurer LP delivers the best quality in our campers to the dealer. Before shipping, every camper has been inspected to ensure it is complete and of the best quality. As with any owner, the dealer must also inspect and reseal units annually as necessary as they await sale.

The dealer will perform a complete inspection of the unit to see that it is free from defects. Your dealer at the time of purchase will walk you through the camper and explain the proper usage of the following.

- Appliances
- Slide-out operation
- RV Hookups
- Electrical Systems
- Loading and Unloading
- Plumbing Systems

## PROLONGED OCCUPANCY

Your truck camper has not been designed for permanent housing or lodging. Using your camper in this manner may lead to deterioration of the structure, interior finishes, fabrics, carpeting and drapes. Damage due to long term use may not be considered normal use may under the terms of the warranty constitute misuse, abuse or neglect, and may reduce your warranty protection.

## LIMITED WARRANTY

Adventurer LP Ltd. Partnership hereby warrants each truck camper manufactured to be free from defects in material and workmanship under normal service and use. The manufacturer's obligation under this warranty shall be limited to repairing or replacing any part or parts therein deemed to be defective upon manufacturer's examination for one year from original retail purchase from an authorized Adventurer Dealer.

Also provided is a **three year transferable limited structural warranty for Adventurer products, and a two year transferable limited structural warranty for Eagle Cap products**, which shall become effective only if the warranty card is properly completed and returned to the manufacturer.

This warranty shall not apply where the product is being used for rental and/or leasing purposes or has been subject to damage caused by misuse, accident, alternation or negligence. This warranty does not cover refrigerators, stoves, water heaters, furnace or any other components, which are protected by their respective manufacturer's warranties. Also, there will be no reimbursement for transportation, gas, food or lodging.

### ***Important Information About Your Warranty***

At Adventurer LP Ltd., we would like to ensure that you enjoy many years of trouble free relaxation in your new truck camper. We ask that you read the terms and conditions of your warranty thoroughly, and understand fully what must be met in order for the warranty to remain valid. In order for the warranty to become effective, the warranty registration card must be properly completed and returned to the manufacturer no later than 15 days from the date of the original purchase from the dealer.

Normal maintenance is the responsibility of the owner. To keep the structural warranty in force, owners are required, at their own expense, to bring their truck camper to their authorized dealer for regular

**ANNUAL INSPECTIONS AND ANY REQUIRED SERVICE.**

The following will be inspected:

- Inspect under floor protection for damage, punctures and a moisture tight seal.
- Inspect all entry doors, baggage and access doors, windows, tail lights, clearance and marker lights, moldings and attachments for a moisture tight seal.
- Inspect all fiberglass joint seams for proper adhesion,
- Inspect all exterior and interior surfaces for proper care and maintenance (e.g. regular wash and wax of exterior siding).
- Inspect all roof moldings, trims, vents, antennas, roof racks and other attachments for moisture-tight seal.

Owners must have all authorized factory repair depots **OBTAIN FACTORY REPAIR**

**AUTHORIZATION PRIOR** to executing any warranty repairs. Any costs associated with transporting the vehicle to the factory or other authorized repair facility is the sole responsibility of the owner.

**CAUTION:** Rubber Roof Repairs. Use Only Proper  
Rubber Roof Caulking Sealant for skylight and all roof  
attachments.

***Exclusions***

The scope of this warranty is expressly limited to only items actually constructed by Adventurer LP. Adventurer LP therefore makes no warranty with respect to component parts constructed or assembled by other manufacturers, including, but not limited to the LPG and electrical appliances, heaters, refrigerators, plumbing fixtures, light fixtures, lights, entrance door and windows. These component parts may be warranted by their respective manufacturers, and copies of such warranties are included with the camper.

This warranty shall not apply to damage caused by abuse, misuse, neglect, alteration, modification, accidents or normal wear and tear. Nor does this warranty apply to parts made out of cloth, leather, wood, paint, or chrome which has been affected by airborne fallout, such as chemicals and tree sap, or by road salt, hail, windstorm or other environmental factors.

No payment or other compensation will be made for incidental expenses, including, but not limited to, towing, telephone, transportation, lodging, travel, gasoline, loss of pay or indirect or consequential damage including, but not limited to, loss of use of the vehicle, inconvenience, damage or injury to person or property, or loss of revenue incurred or sustained by reason of a manufacturer's defect covered by this warranty. Adventurer is not responsible to any purchaser of this recreational vehicle for any undertaking, representation or warranty made by dealers during the course of selling this recreational vehicle, beyond those herein expressed.

As the manufacturer of the camper, which you have purchased, Adventurer LP cannot know the purpose you have in mind for your truck and camper, nor can Adventurer LP know the GVWR of your truck. Therefore, Adventurer LP makes no warranties or representations, express or implied, as to the performance of your truck if the match up of your truck and camper exceeds the GVWR as specified by your truck's manufacturer. Specifically,

there is no express or implied warranty of merchantability or of fitness for the particular match of your truck to any particular camper.

## IDENTIFICATION

Adventurer Mfg. Ltd. Partnership is a Canadian owned company with a reputation for quality and reliability. We build all of our units with Canadian conditions in mind. Each unit is identified with the following labels or plates:

- A. RVIA and ANSI labels are affixed to the exterior of each unit, usually near the entrance door. Adventurer LP meets or exceeds these specifications.

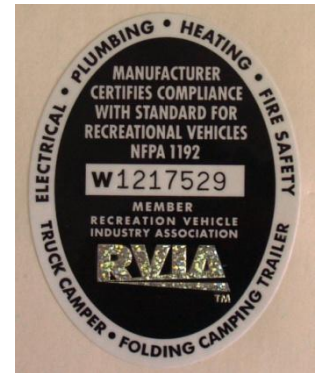

- B. A camper label is attached to the exterior of all truck campers. This label is near the entrance door, and shows the model and serial numbers, date of manufacture and camper mass.

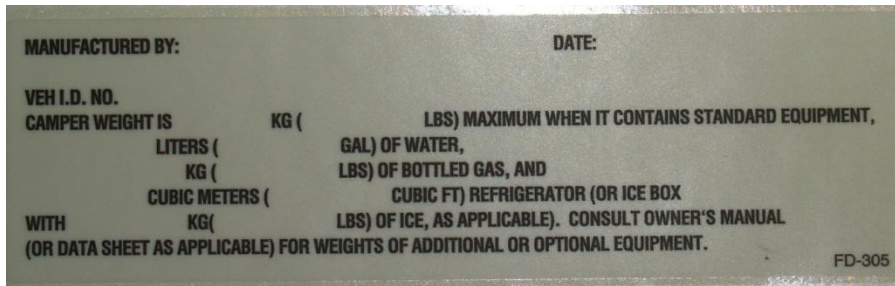

MFGD By  
Adventurer LP Ltd. Partnership  
3303 W. Washington AVE Yakima, WA 98903  
DATE OF MFG. \_\_\_\_\_  
THIS CAMPER CONFORMS TO ALL APPLICABLE  
U.S. FEDERAL MOTOR VEHICLE SAFETY  
STANDARDS IN EFFECT ON THE DATE OF  
MANUFACTURE SHOWN ABOVE  
Camper Weight is \_\_\_\_\_ Lbs. Maximum When  
it Contains Standard Equipment, \_\_\_\_\_ of  
Water, \_\_\_\_\_ of Bottled Gas, and — Cubic Ft.  
Refrigerator or Ice Box With \_\_\_\_\_ Lbs. of Ice.  
Consult Owner's Manual or Data Sheet for  
Weights of Additional or Optional Equipment.  
V.I.N. \_\_\_\_\_

## CENTER OF GRAVITY

On each Adventurer camper (left and right) sidewall is the centre of gravity sticker. The center of gravity should be ahead of the rear axle to transfer more of the weight to the front of the truck.

When packing your camper, store heavy gear first, keeping it on or near the camper floor. Place heavy objects or items far enough forward to keep the loaded camper's centre of gravity within the area recommended by the manufacturer. Store only light objects on high shelves. Distribute weight to obtain even side-to-side balance of the loaded vehicle.

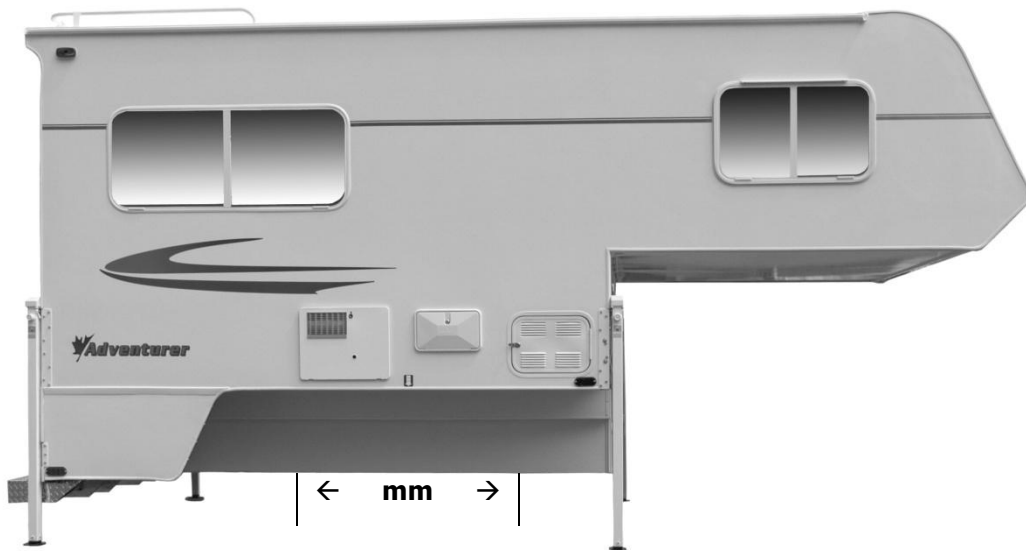

Center of Gravity Location under Specific Loading Conditions



Recommended Center of Gravity Location Zone



## ***Weight Information***

**"NOTE THIS IS A GUIDE ONLY"**. Please ensure that your truck is the right size for the camper you have purchased.

The weight of your truck camper is stated on the camper's serial plate. This weight includes only the **STANDARD EQUIPMENT**, which is listed on the specification nameplate found inside the closet of your unit.

**YOU MUST REMEMBER THAT THE ADDITION OF OPTIONAL EQUIPMENT WILL INCREASE THE WEIGHT OF YOUR CAMPER.**

This should be added to the maximum camper weight figure used to select the appropriate truck. Review your option-listing guide for specific option weight. (Enclosed option weights insert with manual).

When the truck camper is loaded, drive to a scale and weigh the front and the rear wheels separately to determine axle loads. The load on an axle should not exceed its gross axle weight rating (GAWR). The total of the axle loads should not exceed the gross vehicle weight rating (GVWR). Weight ratings are given on the vehicle certification label that is located in the glove box or on the left side of the vehicle door post or door edge. If weight ratings are exceeded, move or remove items to bring the weights below ratings.

**CAUTION:** Camper weights vary depending on the  
dry and wet weight, plus options etc.

It is very important that you properly match your truck and camper to the weights specified by the manufactures. Truck bed sizes and bed to cab heights vary. Make certain that there is a minimum 1 ½ in. clearance between truck cab and camper overhead the camper should sit back in the bed 1 in. from the front rail of the truck box to avoid damage to truck and camper

Adventurer recommends that **SUSPENSION AIR BAGS AND/OR OVERLOAD SPRINGS** be installed on your truck at the time you purchase your camper. You should run with the recommend air pressure in the bags when under load.

## **PROPANE SYSTEMS**

The stove, refrigerator, water heater and furnace are all operated with LP Gas, which is stored in tanks in the propane compartment of your unit. The gas is fed through a regulator that has been pre-set to the correct pressure. DO NOT CHANGE THIS SETTING. Gas lines must be checked periodically for possible leakage. See your RV Dealer for an annual gas (propane) test. A manufacturer's manual has been provided for each of the gas appliances furnished with your Adventurer Camper. Read each of them carefully and operate the equipment in accordance with the instructions.

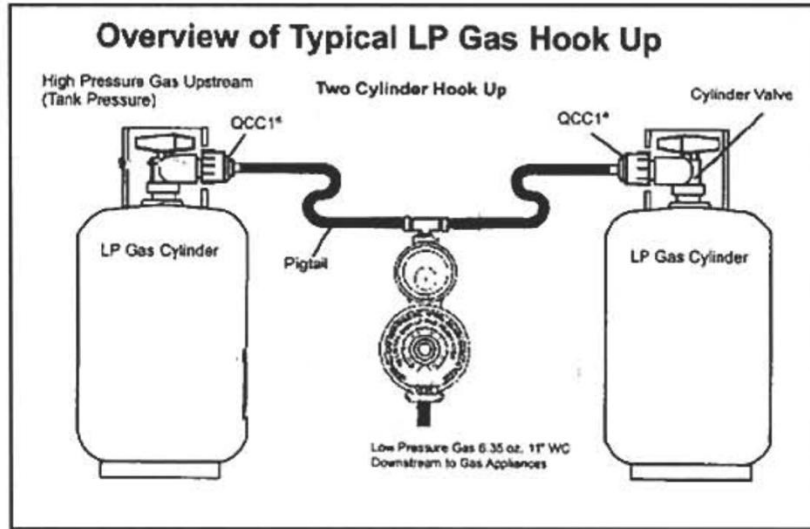

**CAUTION:** LP gas is flammable and potentially explosive. Use proper handling, lighting, and ventilation procedures

### LP Gas Safety Precautions

Historically, LP gas is a safe and reliable fuel. As with any other volatile and flammable material, common sense dictates that LP gas be handled and used with respect and caution. Because LP gas systems are so reliable, they are often taken for granted. Neglect can be a very dangerous habit. If the system is maintained regularly, you can expect almost trouble free operation.

### Filling LP Gas Tanks

**WARNING:** TURN OFF LP MAIN VALVE AND INDIVIDUALLY TURN OFF GAS APPLIANCES OR ELECTRICALLY DISCONNECT AUTOMATIC IGNITION APPLIANCES BEFORE ENTERING AN LP GAS BULK PLANT OR MOTOR FUEL SERVICE STATION.

**WARNING:** DO NOT FILL PROPANE CONTAINERS TO MORE THAN 80% CAPACITY. OVERFILLING CAN RESULT IN UNCONTROLLED GAS FLOW WHICH CAN CAUSE FIRE AND EXPLOSION. A PROPERLY FILLED CONTAINER HOLDS ABOUT 80% OF ITS VOLUME AS LIQUID.

**WARNING:** CANADIAN SAFETY STANDARDS PROHIBIT OPERATION OF AN LP GAS REFRIGERATOR WHILE THE MOTOR VEHICLE IS IN MOTION. ENSURE THAT THE PROPANE TANK VALVE IS IN THE OFF POSITION.

## ***Lighting LP Gas Appliances***

Detailed operating information for the LP appliances can be found in your Info-Pak. Please read and follow these instructions.

**NOTE:** The distinctive odor of LP gas indicates a leak.

### ***If You Smell Gas***

- Extinguish all open flames, pilot lights and all smoking materials.
- Do not touch electrical switches.
- Shut off the gas supply at the tank-valve(s) or gas supply connection.
- Open all doors, windows and vents.
- Leave the area until the odor clears.
- Have the gas system checked and the cause of the leak corrected before using the system.

1. Inspect the entire LP system for leaks or damaged parts before each trip.
2. Do not restrict access to LP tanks. In an emergency the propane tank service valve must be easily accessible.
3. Be sure the tanks are securely fastened in their rack whenever they are mounted in the Adventurer Camper.

### ***Using LP Gas Systems at Low Temperatures***

Your gas system will function at low temperatures provided the system components are kept at a temperature above the vapor point of the LP gas.

**CAUTION:** Butane vaporizes at 32°F and propane at about 40°F. Choose a type of LP gas that has a boiling point approximately 40°F lower than any temperature you expect to encounter.

LP gas systems can and do freeze up in very cold weather. It is a common misconception that the regulator or the gas itself freezes. Actually, it is moisture or water vapor that gets trapped in the system or is absorbed by the gas that freezes and causes the problem. This ice can build up and partially or totally block gas supply. There are a number of things you can do to prevent this freeze up:

- Be sure the gas tank is totally moisture-free before it is filled.
- Be sure the tank is not overfilled. This is also a safety consideration.
- Keep the valves on empty tanks tightly closed.
- Have the gas tanks purged by the LP gas service station if freeze up occurs.

## FIRE AND SAFETY

### LPG Leak Detector

An installed LP gas leak detector is located near the floor in the galley area. The unit contains an alarm that will sound alerting you to the presence of low levels of potentially dangerous LP gas that may have been released due to a range top or oven burner flame loss, a gas piping leak, or an incorrectly adjusted appliance burner.

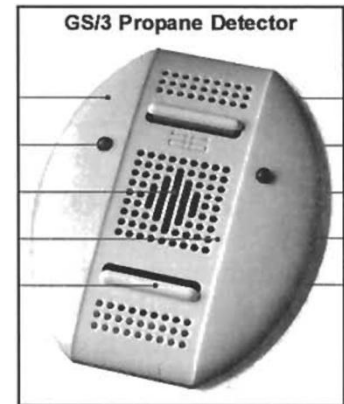

**WARNING: THIS PROPANE DETECTOR DETECTS THE PRESENCE OF LP GAS. IT DOES NOT DISCONNECT THE GAS SUPPLY.**

### Combination Smoke & Carbon Monoxide Detector

Most fire casualties are caused by inhalation of toxic fumes (smoke) from a fire and not by flame. The combination smoke & carbon monoxide detector has separate sensing chambers for smoke and carbon monoxide that work independently of one another. It is battery powered and complies with UL-217, ULC- S531, and CSA 6.19-01. It is located in the living/cooking area of your camper. Please read the Owner's Manual for details on testing and caring for this important safety device. Test the device after the camper has been in storage, before each trip, and at least once a week during use. Turn the device counterclockwise to remove it from the bracket.



The detector should never be disabled due to nuisance or false alarm from cooking smoke, a dusty furnace, etc. Ventilate your camper with fresh air and the alarm will shut off.

### **DO NOT DISCONNECT THE BATTERIES**

Replace the batteries once a year or immediately when the low battery "beep" signal sounds once a minute. The detector uses two standard "AA" batteries, usually available at any retail store that sells batteries. Test the operation of the detector after replacing the batteries. If the detector fails to operate with new batteries, replace it with a new unit.

The fire extinguisher in your camper is located near the main entrance door. Read the operating instructions that are printed on the extinguisher. You and your family should be familiar with fire extinguisher operation. Your fire extinguisher should be replaced immediately after use or discharge.

## Electrical System

Most electrical systems in your truck camper including the lighting, operate on 12-volt. 12-volt power is supplied from the battery of the truck, or an auxiliary battery which can be installed in the camper. In addition, your unit is equipped with a 110-volt 25amp power supply cord, which can be plugged into any available outlet. This current goes into the 32 amp converter, which changes it to 12-volt before feeding it into the circuits. This system automatically switches to batteries when disconnected from external 110-volt, or vice versa. Auxiliary batteries are charged through the alternator of the vehicle and/or through a built-in charger in the 32 amp converter.



**NOTE:** Do not install fuses with amperage ratings greater than that specified.

### ELECTRICAL CONNECTION TO TRUCK

The truck electrical connector and cord may be installed by the Eagle Cap Campers, Inc. dealer, according to your truck wiring system. With the wiring and connectors hooked-up, your truck will supply 12-volt DC power to charge your camper battery and provide power for the 12-volt power needs while the truck is operating. See the listing below for 12-volt connector wire colors, wire gauge and function:

**Note: Do not use less than 10 gauge wire size for charge lines. Also, do not attach them to smaller gauge wires.**

Your Dealer should ensure that the wiring between the vehicle and your unit is adequate for the demand system.

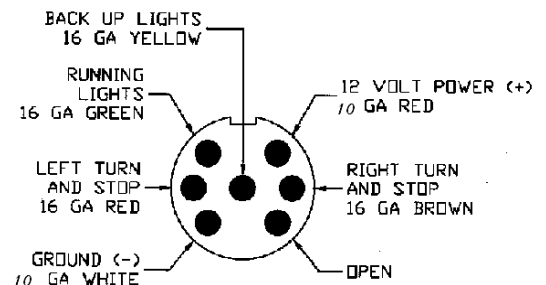

### Ground Fault Interrupter

Bathroom and patio 120-volt electrical outlets are protected by a Ground Fault Interrupter (GFI). This device is provided in compliance with ANSI A119.2/NFPA 501C CSA requirements and is intended to protect you against the hazards of line to ground electric faults and electrical leakage shocks possible when using electrical appliances in bathroom or damp areas.



and  
the

### Systems Monitor Panel

The systems monitor panel incorporates controls and instrumentation concerning the electrical and fluid systems. Some models also have switches for optional automatic water heaters and generators.

## **Water Pump Control Switch**

This rocker switch controls the on demand water pump. The water pump is pressure sensitive and starts (with the switch ON) when a faucet is opened, causing pressure in the line to drop. When the faucet is closed, pressure builds in the line and the pump stops.

## **Monitor Panel-Levels Indicators Switch**

When depressing the monitor switch, indicator lights for the black (waste), gray (sink), fresh water tank and battery charging illuminate, indicating the existing condition of each component.

### **Erroneous indications when checking water levels can be caused by:**

Water with low a mineral content. Level is measured by a very low electrical signal traveling through the liquid. Some water which is low in mineral content, may not conduct the signal properly. Check the panel reading when the fresh water tank is filled.

Material trapped on the sides of the holding tanks may give a full reading when the tank is actually empty. Use of a spray to wash out the tank following dumping should help prevent this condition.

**NOTE:** If the sensor probes mounted in the tanks get coated with grease, the monitor panel may indicate falsely or not at all. Avoid pouring grease, oils, or similar substances down drains or the toilet. If this is unavoidable, the holding tank(s) should be washed out with a soapy water solution.

When testing approximate battery condition, first turn all lights, fans and other 12-volt equipment OFF. If the battery is being charged the charge light will illuminate when the monitor switch is depressed. If only a weak light is illuminated, discontinue use of all 12volt equipment until the battery can be recharged.

## **WATER SYSTEM**

**WARNING: WATER TANKS SHOULD *ONLY* BE FILLED WHEN THE CAMPER IS ON THE TRUCK OR IF THE FLOOR IS SUPPORTED.**

### **Fresh Water Tank**

Filling the fresh water tank should ONLY be done if the camper is on the truck, or if the floor is supported. Failure to do so may result in damage to the unit.

The dual water systems in our campers supply water from either the unit's storage tank or directly from a city water hookup. Your unit either has a hand pump system or a demand water system. In those units



without a washroom and demand system, your camper comes with a hand pump which draws water from a water tank. A small 12-volt water pump is available which pumps water through the hand pump. There is a separate faucet for the city water hookup on these units. With the demand system, to draw water from the unit's storage tanks, an electrically operated demand pump has an ON/OFF switch for shutting down the system while traveling, while hooked up to city water, or when the unit is not in use.

### City Water Hookup

To use the city water system, simply attach a potable water hose from a service faucet to the city water connection. When the faucet is turned on, water will be supplied to the unit, including the water heater. Filling the portable water tank can be done by means of a hose or a bucket. Periodic draining of the tank and flushing it with a tablespoon of baking soda will keep it fresh and clean.

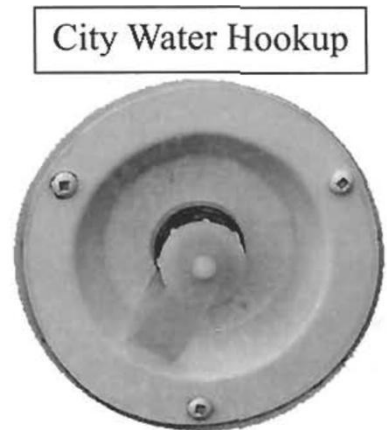

### Hot Water Tank

If your unit is supplied with a hot water system, carefully read the manufacturer's operating instructions. Following these directions will ensure an adequate supply of hot water at all times, wherever you are. The correction of a failure, though rare indeed, is not a job for the do-it-yourselfer. There are hundreds of authorized service centers across the country. Your Dealer is probably one of them.

## WASTE WATER SYSTEM

Your truck camper may be equipped with one or more waste water holding tanks. One is known as the grey water tank, for waste from shower and kitchen and bath sinks; the second is for sewage. Both have their own drainage valves, but empty through the same outlet. To drain, connect the outlet to a dumping station with a sewer hose and open the large valve for the toilet tank and let it drain. Then open the smaller valve to drain the grey water tank. Add clean water and a good deodorant chemical to keep tanks clean and fresh at all times. When connected to a sewer in a trailer park, the toilet holding tank valve should remain closed until the tank is almost full. Then drain and recharge black water tank as above. This method will avoid undesirable buildup in the tank.

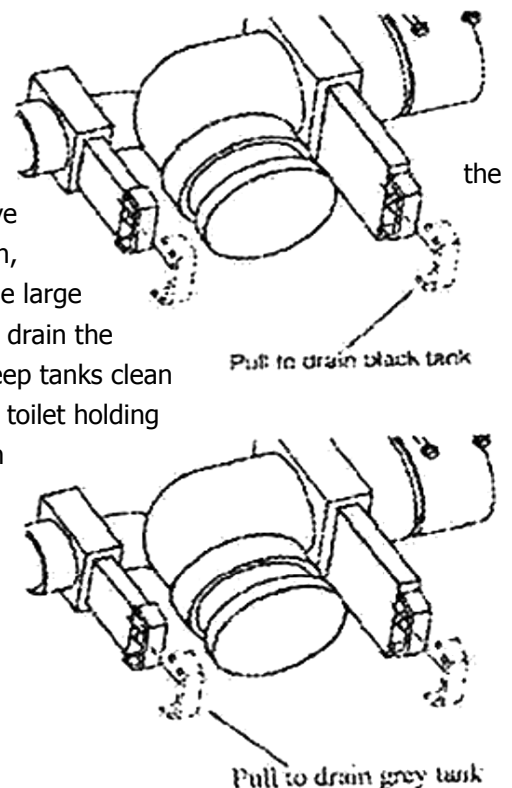

## LOADING YOUR CAMPER ONTO YOUR PICKUP

**CAUTION:** Never raise the back of your camper higher than the front

Never raise the back of your camper higher than the front or it may tip forward, and damage to the unit may occur. When camper bed is clear of the truck slowly drive truck forward, being careful not to hit the jacks. To lower the camper, reverse the above procedure bringing the camper down to the bottom of each jack, and then you can level your camper.

### *Loading the camper*

- Insert crank handle (if using manual jacks) firmly into the crank socket of the jack. Starting at the front begin cranking.
- Extend each jack no more than 4 - 6" at a time at all four corners starting with the front jacks, keeping the camper as level as possible at all times. Repeat this process until the camper is clear of the truck body bed by approximately 6". (If there are two people working the jacks, one on each side, it is a very easy task)
- Slowly back the truck under the camper making sure to clear the wheel wells.
- Continue backing up until the truck is within a foot of loaded position. Stop and connect the 12-volt power cord to the 12-volt receptacle in the truck bed. Before continuing check to see that the distance between the front of your truck and the bumper is at least 1" less than the distance between your truck tail lights and the camper's side boxes. If not, add an appropriate wood shim in the front of the truck bed before continuing.
- Continue backing under the camper until the bumpers mounted on the front corners lightly touch the front of the truck bed.
- Slowly lower both rear jacks, then front jacks until the camper is resting fully on the truck bed.
- Raise the jack base pads and secure in place according to manufacturer's directions.
- If equipped with swing out brackets, lift the swing front jacks inward
- Secure the camper to the truck with a set of high quality tie downs. It is RECOMMENDED that the front tie downs be spring or shock loaded, while the rear be solid turnbuckles.
- Install both the front and rear tie down as per the manufacturer's directions
- Stow remote control or jack crank handle for future use.

### *Tie-downs or Turnbuckles*

After loading your camper, it must be secured to your truck with a set of tie downs or turnbuckles. *Adventurer recommends that Turnbuckles should be spring or shock loaded at the front, and solid in the rear.* We recommend high quality tie downs or turnbuckles. The turnbuckles connect the camper eyebolts to the tie down hardware installed on your truck. Check eyebolts, turnbuckles and bracket bolts before each trip and at frequent



intervals. Refer to the manufacturer's maintenance instructions supplied with the tie downs or turnbuckles for more information.

**CAUTION:** Over-tightening TIE DOWNS or turnbuckles may result in damage to the unit.

### ***Towing and Hitch systems***

- A hitch system should be installed on your truck by **QUALIFIED PERSONNEL ONLY**.

**CAUTION:** Towing will change the handling and braking characteristics of your truck and camper

### ***Loading Cargo***

When loading your camper, store heavy gear first, and place down low. Distribute weight as evenly as possible from side to side. Remember overloading or uneven loading can create serious safety hazard and may shorten the service life of chassis components. Do not load upper cabinets with heavy items. Secure and brace stored items so they won't move during travel, thereby shifting the load in the camper.

Do not load heavy items near the end of the camper or on the rear bumper. Carry only as much water as needed for travel use to balance the load. Whenever possible, empty the waste water holding tanks before traveling.

### ***Carrying Capacity***

The number and size of storage components and liquid tank capacities are maximized for value and convenience. If the camper operator fills all liquid tanks to capacity, and fills all storage compartments and cupboards to maximum volume, the truck may exceed its GVWR. The **operator** is responsible for analyzing the conditions under which the truck and camper will be used for each trip. After you have determined how much weight you can safely carry and selected those items to make up that weight, make a list and keep it for future reference.

## UNLOADING YOUR CAMPER

There are presently two types of jacks used on our truck campers. They are Happi-Jac manual and Happi-Jac electric with wireless remote models.



**Electric Wireless Remote Screw Jack**



**Manual Screw Jack**

**CAUTION:** When unloading your camper be sure all tie downs and electrical connections are disconnected

**WARNING: USE EXTREME CAUTION WHEN UNLOADING YOUR CAMPER IN A STRONG WIND**

**Load And Unload Your Camper on level ground, never on an obvious grade.**

Release locking lever (Down Position) at top of jack when cranking.

Be sure to reset locking lever (UP Position) when jacks are not being cranked to avoid accidental extension.



**Locked**



**Unlocked**

**CAUTION:** Do NOT leave jacks in the Unlocked position for an extended period of time

## ***Operating Remote Control Electric Jacks***

**NOTE:** Do not over-extend or over-retract jacks. Each jack has built in stops. If excessive force is applied against the stops, damage to the jacks may occur.

Electric jacks need 12-volt automotive battery power to operate. The camper battery must be charged and in good condition. If the battery is too low to operate the jacks, charge the battery before using jacks. If the camper is on the truck, starting the truck's engine will supply power to the jacks as long as the 12-volt electrical cord is connected. If no power is available, use the manual override operation noted below.

**NOTE:** Do not use the electric jacks to raise or lower the camper using only 120-volt power. The converter's charger will be damaged if the jacks are operated with 120-volt power through the 12-volt converter without an automotive battery or with a low battery. *A well charged battery in good condition is required.*

**NOTE:** Before operating the remote control electric camper jacks, be sure to read and understand the operating instructions that were provided with your camper pertaining to their safe operation.

The jacks are operated with a hand held remote control. To activate, locate and press the remote control into the receiver, located inside the camper at floor level, near the entry door. A light on the face of the control switch will illuminate when activated. The switch is on a time delay that will automatically shutoff 10 minutes after activation. After use, store the remote unit in a secure place away from access by children.

### **To lift camper follow these steps:**

Press and hold the "ALL JACKS EXTEND" button. All four jacks simultaneously extend until they touch the ground. Release button. Check to make sure that all jacks are touching the ground. If not, use the jack buttons to extend each jack individually until all four jacks are touching the ground.

Extend front jacks first. Extend front jacks so camper is 4" higher in front than in the rear.

Once the camper front is higher than the rear, press and hold the "ALL JACKS EXTEND" button. Release the button when the camper is at the desired height. **MAKE SURE THE FRONT OF THE CAMPER**

### **STAYS HIGHER THAN THE REAR.**

Use the individual jack buttons to adjust an individual jack. Press and hold the extend or retract buttons for the individual jacks as needed to keep the front of the camper 4" higher than the rear, to prevent tipping over the camper. Keep all corners within 4" of level with each other.

**NOTE:** If you are going to leave the camper on your truck disconnect your tie downs before leveling your camper with the jacks.

### **To lower camper follow these steps:**

Retract rear jacks first so the camper is 4" lower in the rear than in the front.

Once the camper has the rear lower than the front, press and hold the "ALL JACKS RETRACT" button and retract until the camper is at the desired height.

Use the individual jack buttons to adjust an individual jack. Keep all corners within 4" of level with each other.

---

**TIP:** Use plywood pads under each jack to keep from sinking in the ground or asphalt. For added safety and stability, support the camper floor with blocks and use camper jacks to stabilize.

## ***Dually Brackets***

### SWING-OUT BRACKETS (OPTIONAL)

To load or unload campers on dual rear wheel trucks, swing-out brackets are installed on the front jacks to clear the fender. To operate, follow the steps below:

1. Lift jack from the travel notch locked position and swing outward from the camper body.
2. Position jack so when camper jack is lowered, the notch and raised tab engage to prevent rotation.
3. Repeat the process for the other front mounted jack.
4. Follow the standard camper loading and removal procedures below.

**NOTE:** Keep children and animals away from the area when raising or lowering the camper. Avoid putting any part of your body under the camper during the procedure.

## **CAMPER FEATURES**

### ***Vents***

All exterior vents and louvers provide air circulation. Ensure that these vents are not blocked, as equipment damage, or hazards to occupants may result.

### ***Lighting***

Your camper is equipped with exterior lights to conform to state and federal regulations. It is important not to alter the lights or reflecting markers. Replace any burned out bulbs or damaged parts as soon as possible.

### ***Bathroom***

The toilet is designed to flush with a minimal amount of water and still provide for proper disposal and odor control. Toilet chemicals are available at most RV retail locations. Review the booklet supplied with your toilet for proper operation and maintenance.

### ***Dinette Bed***

All Campers come equipped with a dinette that will convert into an additional sleeping area. Your dealer will provide instruction on the proper conversion of this area.

- Remove or fold table pedestal or leg
- Place filler panel (table) on the supports of the seat platforms
- Arrange seat and back cushions to provide a full mattress across the new bed area.

## ***Ladder and Roof Rack***

If your camper is equipped with a ladder, it may be used to access the roof. The roof rack is designed to secure light bulky items. Some models have a ladder located in front of the storage or generator access door. In order to gain access to the door, the ladder's lower section is hinged allowing it to swing up and be secured in place.

## ***Cab-Over***

In case of emergency or fire, an emergency escape window or escape hatch is located in the cab over area of each unit.

## ***Storage***

Interior storage areas may be found in a number of places in your camper; overhead compartments, wall closets, P.J. boxes, under the dinette seats, and galley cabinets for your convenience.

Some doors have hidden latches. To open, locate the recessed latch along the bottom edge (upper cupboards), side edge (wardrobes) or top edge (lower cupboards) and press.

## **APPLIANCES**

For proper appliance lighting, operation and maintenance, consult the appropriate appliance manufacturers reading materials contained in the truck camper's Info-Pak

### ***Lighting LP Gas Appliances***

Air trapped in the gas lines may delay the initial lighting of any appliance. It could take several seconds or longer for the gas to reach the appliance. The first time the furnace or oven is lit; paints and oils used in the manufacturing process may generate some smoke and fumes. If this occurs, open doors and windows to air out the camper.

**NOTE:** Always follow the appliance manufacturer's lighting and operating instructions, found in the truck camper's Info-Pak

### ***Microwave Oven***

This optional item should never be operated when empty. Please consult the manufacturer's owner's manual.

### ***Refrigerator***

The refrigerator operates on 12-volt DC power, 120-volt AC power and LP gas. The operating instructions supplied in the Owner's Information Package will help you with detailed information from the manufacturer.

The recreational vehicle LP type refrigerator operates on the "absorption" principle and therefore **MUST BE** reasonably level. When your camper is stationary, it should be leveled for comfortable living. If you can occupy the camper comfortably, the refrigerator unit should perform well. If the refrigerator unit is not "close to level", it may not function properly and your food will not be adequately cooled.

When the camper is in motion, the continuous movement will not affect operation. The operating instructions are printed inside near the controls and may be found in the manufacturer's instruction manual.

### **Operating Tips**

- Operate the refrigerator on 120-volts for 8 to 12 hours (overnight) before you leave on a trip. This will allow the refrigerator and freezer to get cold and even have some ice ready.
- Pre-cool food and drinks before putting them into the camper refrigerator.
- For off-truck use, some refrigerator models must have 12-volt battery hookup to power the electronic controls. Refer to the supplied appliance manuals for proper operating instructions.

### ***Water Heater***

Before lighting, open the water heater relief valve and run until water flows without the presence of air. Do not operate the water heater until it is filled with water.

### ***Range / Oven***

Gas burners and the oven use Light Petroleum (LP) gas for fuel. All campers are equipped with a spark igniter for lighting the top burners. The 3 burner range used in some of our models is equipped with one high output burner when additional heat is required. Cooking appliances require fresh air for safe operation. Before use,

- Open overhead vent or turn on exhaust fan
- Open window or door

**NOTE: It is not safe to use cooking appliances for comfort heating. Do not use open flames to warm the living area.**

## **OPENING THE SLIDE OUT**

**CAUTION:** Always make sure the camper is level before putting slide out, or damage to camper may occur

The switch for the slide out is located just inside the entry door close to the floor or on a wireless remote for your convenience. Which switch your camper has is dependent on which camper model you have purchased.

**Remember your camper must be level before putting slide out or in, or damage may occur.**



Slide when in



Slide when out

### ***Operating The Full Wall Slide (Adventurer Models)***

**Your camper MUST be level before attempting to put the slide out.**

- Locate the **slide on/off switch** right next to the slide operation switch
- Switch to on position.
- Hold slide operation button in the out position until the slide is fully out.
- To bring the slide back in, hold the button in the in position until the slide is fully locked in position.

### ***Slide Out Manual Operation (Adventurer Models)***

If the slide fails to operate because of a slide motor malfunction, dead battery, etc. please do the following:

- Locate the **slide on/off switch** right next to the slide operation switch
- Switch to off position to enable manual mode
- Remove the plastic cap at rear of camper on the same side as the slide room
- install slide crank onto socket of motor turning crank until slide is all the way in

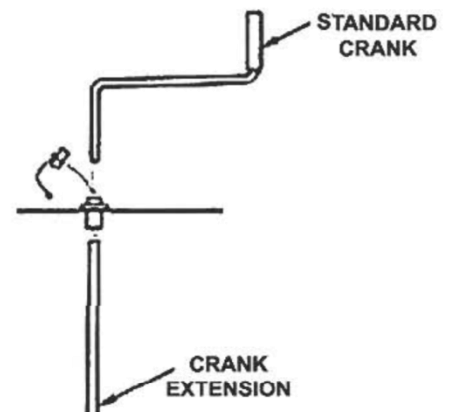

- return slide on/off switch to the on position

**If slide fails to function you have to manually operate it.**

It will take two people to crank the slide in; one holds the power button at floor by the entrance door, while the other person slowly cranks the slide. Do not try hurry the slide; keep steady pressure on the crank handle until the slide is in the retracted position. Turn the power switch to the off position (manual) and have other person hold the in/out switch button in, when you hear a click the brake on



level  
to  
fully  
the  
the

motor has been released.

**You can now start cranking slide in.**

**CAUTION:** This procedure should be used in an emergency only.

**Operating The Full Wall Slide (Eagle Cap Models)**

**Your camper MUST be level before attempting to put the slide out.**

- Locate the ACC IN/OUT switch on the remote control.
- Hold button in the out position until the slide is fully out.
- To bring the slide back in, hold the button in the in position until the slide is fully locked in position.

**Slide Out Manual Operation (Eagle Cap Models)**

If your camper has a loss of power please follow the steps provided for your specific model.

**850, 950, and 1050 –**

1. Locate the manual crank handle with the longer shaft than the jack crank handle. (In some cases you will also need the Black extension rod that attaches to the end of the crank).
2. Insert the crank handle thru the rear of the unit into the mechanism under the slide out.
3. Open access panel in underneath dinette seat and unplug 12g wires at junction box.
4. Crank the slide out all the way out until the seals are touching.

**995, 1160 and 1165-**



1. Tools needed are a Phillips head screw driver and a ¾" wrench.
2. Locate the access panel directly under the slide mechanism in the wing of the camper.
3. Remove the eight screws to gain access to the mechanism.
4. Use the 3/4" wrench to manually slide the room out.
5. On the 1160 you will also have to remove the fabric skirt on the interior of the camper for the rear slide out to gain access to that mechanism.
6. Open access panel in underneath dinette seat and unplug 12g wires at junction box.

## **MAINTENANCE**

### ***Maintaining Exterior And Interior Finishes***

#### **Exterior:**

The baked enamel finish or fiberglass of your truck camper will withstand sun exposure while maintaining its appearance. Periodic washing and waxing can enhance the life of the exterior. Do not use harsh abrasives or strong solvents to clean the surface, as this may result in discoloration or damage

#### **Interior:**

The interior of your truck camper is finished with high quality paneling. Regular cleaning with warm, soapy water and an application of furniture polish will preserve its beauty. Do not use self-adhesive hooks or fixtures, masking or scotch tape on the paneling. These may damage the finish and leave unsightly marks when removed. A surprising range of items can be supported by common straight pins. When removed, the tiny hole is almost invisible.

#### **Drapes and Upholstery:**

Window draperies, valances and upholstery should be treated in a like manner to those in your home. Remember that they will be subjected to more sunlight than is usually normal and so should be given extra care and attention. Never dry-clean your cushion covers, as this will result in the vinyl backing disintegrating. Use upholstery cleaner, which is sprayed on and vacuumed off when dry. The drapes should not be dry-cleaned either. They should be washed in warm water only, as hot water may damage the plastic glides.

**NOTE:** CSA regulations prevent fabric blinds adjacent to flame sources i.e. gas cook tops.

#### **Floors and Carpeting:**

Vinyl flooring requires only washing and periodic waxing. Vacuum carpeting regularly and clean with a good quality carpet cleaner.

#### **Power Range Hood:**

Clean the filter in hot water and detergent, and wipe down the surface with mild soap and water. Use a soft cloth to dry.

**Refrigerator:**

Clean interior with mild soap and water after each trip. When defrosting, be sure the drip tray is in place under the finned evaporator. The water will be carried through the drain tube to the outside of camper. Check the drain tube periodically to assure it's not plugged.

**Shower Care:**

For cleaning use a non-abrasive cleaner. Household cleaners are recommended. Never use harsh detergents, abrasive cleaners or steel wool to clean the fiberglass surface.

**Drains:**

If sinks fail to drain do not use strong chemicals. A standard wire drain cleaner is recommended.

**WINTERIZATION AND WINTER STORAGE**

Winter in most parts of North America can be harsh, and can take its toll on almost all types of vehicles and equipment. The rigors of winter should not discourage you from enjoying the RV life-style, though. Thoughtful planning and preparation for the winter season can help eliminate equipment failures and breakdowns, and can extend the life of your RV and its systems.

Your Dealer can advise you concerning specific winterization procedures and products for your climate area or the areas through which you will be traveling. Your Dealer may also provide winterization service for all appliances and systems in the recreational vehicle. A 'physically fit' RV will stay in shape much better through the winter. If you choose not to travel during the winter and will be storing your unit during periods of freezing temperatures, follow a thorough winter storage procedure.

## Winterizing Your Camper

**CAUTION:** Draining the water system alone will not provide adequate cold weather protection. If the camper is to be unheated during freezing temperatures, consult your dealer for the best winterizing procedure for your climate. Your dealer can winterize your camper for you or can supply you with one of the special antifreezes, that are safe and approved for use in RV water systems. Follow the instructions furnished with the antifreeze.

**WARNING: DO NOT USE AUTOMOTIVE OR WINDSHIELD WASHER ANTIFREEZE IN THE CAMPER WATER SYSTEM. THESE COULD BE HARMFUL IF SWALLOWED.**

- Open hot and cold water faucets, open the drain valves on **HOT** and **COLD** water pipes.
- Drain the water heater by opening the drain valve at the bottom of the heater and open the safety valve. Open the hot water faucets.
- Open all cold water faucets, and depress the flush pedal or pull the flush levers on the toilet. When each faucet has been opened, drained, and closed, close the water line drain valves, and fresh water tank drain valve.
- Drain the showerhead by opening the valve. Let all water drain out the tub spout. Leave the valve open.
- Be sure ALL water from ALL plumbing fixtures has been drained.

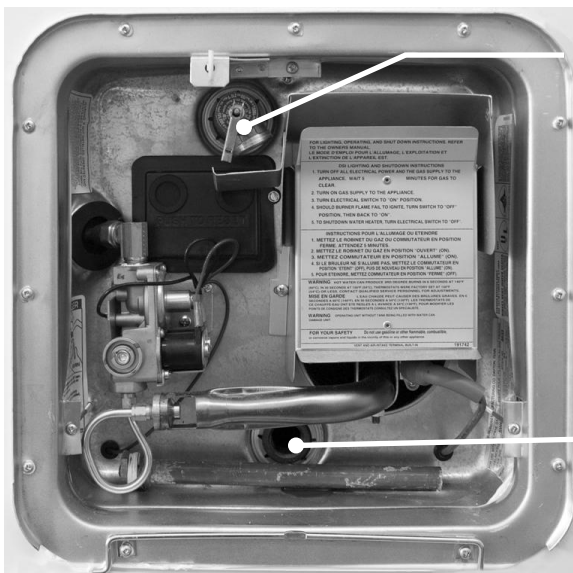
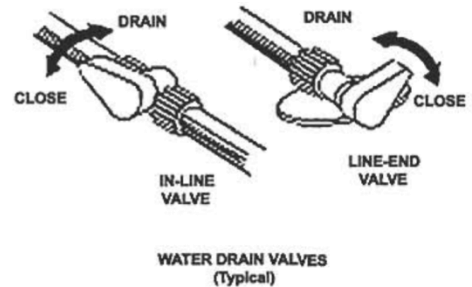

**Pressure Temperature Relief Valve**

**Drain Plug**

- If your unit is equipped with a water heater bypass valve, close the valves to by-pass heater tank.
- Make sure fresh tank drain valve is closed. Pour one gallon of RV approved non-toxic anti-freeze into the fresh water tank.
- Turn the water pump master switch to ON and run pump through galley faucet for 20 seconds.
- Turn the water pump master switch to off.
- Drain approximately one cup of anti-freeze from fresh water tank drain, cold low point drain, and hot low
- Insert the hose from the winterizing valve into a non-toxic anti-freeze.
- Turn the valve to have the pump pick up from hose.
- Turn the water pump master switch ON.
- Open each cold water faucet, run the water pump and let about a cup of antifreeze solution flow continuously through each faucet. Close each cold water faucet.
- Open each hot water faucet and repeat the above.
- Depress the flush pedal (or otherwise operate the flush mechanism) on the toilet until the antifreeze solution flows continuously. Release flush mechanism.
- Pour a cup of antifreeze solution down each drain.
- After the water systems are completely filled with antifreeze, remove the water purifier filter cartridge if equipped.



**Normal Flow**



point drain.  
cont: **By-Pass Mode** ed

**Install all protective caps:**

- Water tank fill
- City water inlet
- Waste tank drain outlet

**Winterization of the fresh water system is complete.**

**Drain the waste water system.**

- Apply graphite lubricant to the knife valve actuator rod.

***Preparing Your Unit For Storage***

The following checklists will help you perform the steps necessary to prepare your recreational vehicle for storage. Use the checklist that applies to the storage conditions you anticipate. These checklists will not include every detail required, and you may want to expand them to suit your needs.

### ***Short-Term Storage Above Freezing (Less Than 60 Days)***

- Camper should be level as possible front to rear and side to side.
- Check the charge in the battery with a hydrometer. Hydrometer reading should be 1.255. Add clean drinking quality water when necessary to maintain electrolyte level, and charge to a reading of 1.255.
- Remove battery cables. Clean terminals, top and sides of batteries and battery boxes. Leave the battery disconnected.
- Drain holding tanks, toilet, and living area water systems. Turn off water pump and water heater master switches.
- Turn off LP gas at tank valve.
- Turn off refrigerator and furnace.
- Turn all range and oven burner valves and pilot valves (if equipped) off.
- Remove all perishables from refrigerator and kitchen cabinets. Block refrigerator door open to reduce odor buildup. An open box or tray of baking soda in the refrigerator will help absorb odors.
- Open closet doors, dressers and cabinets so air can circulate through them.
- Close all roof vents. Be sure vent fan and range hood fan switches are off.
- Cover exterior vents (water heater, furnace, range hood and refrigerator) to prevent insects from getting in. Be sure to remove all covering material before using appliances or vents.
- Cap or close holding tank drain, city water inlet and fresh water fill spout.
- Turn off all radios, TVs and interior and exterior lights.
- Close drapes and curtains.
- Check the unit weekly.

### ***Long-Term Storage Above Freezing***

- Perform all of the preceding. Operate air conditioner periodically to lubricate compressor seals.
- Disconnect battery and check charge (Specific Gravity) with a hydrometer every 30 days. Recharge as necessary.
- If you expect to store the unit for an extended period, you may want to support the weight of the unit on appropriate blocks or jack stands. Do not use hollow core concrete blocks for blocking.
- Remove high grass or weed growth under or around the unit.

## ***General Camper Winter Storage Checklist***

- Perform steps as listed under Long-term Storage checklist.
- Close and cover all vents to prevent entry of snow or small animals and insects.
- Check the sealant around all roof and body seams and windows. Reseal if necessary.
- Lubricate all locks and hinges with light oil or graphite.
- Support the weight of the unit on appropriate blocks or jack stands as outlined above.
- During extended storage charge and remove the battery. Store it in a cool, dry place, and check the charge and water level every 30 days.
- Mattresses and cushions should be propped up to allow air flow, and prevent moisture damage or mold growth.
- Remove all perishables and canned goods.
- Clean refrigerator and prop door open to allow circulation of air.
- Remove, clean and replace air conditioner filters.
- Cover the air conditioner shroud(s).
- Mask the windows on the inside to reduce curtain, drape and carpet fading.
- Thoroughly clean the interior of the unit, including carpets, counter tops, toilet, tub & shower and galley.
- Remove batteries in clocks or other battery-powered devices.
- Remove snow accumulations as often as possible.

## ***Reactivating the Unit After Storage***

- If the unit was properly and carefully prepared for storage, taking it out of storage will not be difficult. You should not experience any problems except minor surprises such as animal nests underneath or minor body scratches, and of course dirt accumulations on the outside. The following procedure checklist assumes that you stored the RV with care. If you didn't, and extensive freeze damage or other serious deterioration has occurred, please consult your Dealer for advice.
- Thoroughly inspect the outside of the camper. Look for animal nests in appliance vents, wheel wells or in other out of the way places.
- Open all doors and compartments. Check for animal or insect intrusion, water damage or other deterioration.
- Remove all appliance and ceiling vents and air conditioner coverings. Be sure all furnace, water heater and refrigerator openings are clear and free of debris or insect nests, webs, etc.
- Check charge level in battery. Refill and recharge as necessary. Reinstall battery if necessary. Be sure cable ends and terminals are clean and free of corrosion.
- If unit has been stored on blocks or jacks, remove these.
- Open vents and windows for ventilation.
- Be sure all 12-volt and 110-volt circuit breakers are off.
- Check the operation of tail lights, turn signals, backup lights, clearance lights, license plate light and emergency flashers.

**Drain, flush and sanitize the fresh water system.**

1. Drain residual antifreeze from fresh water tank.
2. Fill fresh water tank with fresh water.
3. Turn bypass valve to BYPASS position.
4. Turn water pump ON.
5. Open water faucet farthest from water tank until clear water appears. Shut off faucet. Repeat at all other faucets, showerhead and toilet.
6. Turn bypass valve to NORMAL position.
7. Open hot water faucet until clear water appears.

Repeat steps 2 through 7 as necessary to assure clear water is flowing through all parts of the system.

**The fresh water system is now ready for use.**

- Drain the holding tanks. Inspect the drain hose for leaks. Replace if necessary.
- Operate all faucets and fixtures in the fresh water system. Check for leaks at all joints and fittings. Repair if necessary.
- Inspect the LP gas system. Remove the regulator cover, check for damage. Inspect all pipes and fittings in the system. If the propane tanks show signs of rust or corrosion, sand and paint it as necessary.
- Turn on 12-volt circuit breaker and inspect fuses. Operate all 12-volt lights and accessories.
- Install new batteries in battery-operated devices (smoke detector, carbon monoxide and clocks).
- Check monitor panel operation.
- Open and operate vents and vent fans, including the range hood fan.
- Operate each gas appliance. Observe all burner/pilot flames for proper color and size. In any case, have the LP gas regulator adjusted for proper pressure.
- Inspect the 110-volt electrical system and power cord, converter, all outlets and any exposed wiring. If defects are found, refer service to your Dealer.
- Turn on 110-volt circuit breakers.
- Operate 110-volt appliances and air conditioners. Be sure to uncover air conditioner shroud(s).
- Inspect and clean the interior.
- Check the sealant around all roof and body seams and windows. Reseal if necessary.
- Lubricate all exterior locks, hinges, and latches.
- Wash and wax the exterior. Inspect the body for scratches or other damages.

Your truck camper should now be ready for a new traveling season. If you choose, your Dealer can double-check your preparation and correct any defects or make any necessary adjustments.

## **TRAVEL TIPS**

Before leaving your campsite area, it would be wise for you to have a card made out with the following items on it to be used as a check list.

- Power Cable disconnected
- Sewer Line disconnected
- Water Line disconnected
- Step up
- Hatches and Vents closed
- Refrigerator locked
- TV. secured and Antenna down
- Doors and Drawers shut and Curtains tied
- Mirrors aligned

### ***Some Useful Equipment to Take Along***

- Tool box and an assortment of small tools
- Plastic bucket for carrying water
- Blocks for leveling your recreational vehicle
- RV water hose (high pressure) and 'Y' connection in case of 2 units on one water outlet
- Sewer hose
- 100 ft., 3 wire electrical cord with at least 30 amp capacity
- Spirit level. A level camper is required to keep refrigerator operational
- Short handled shovel
- First Aid Kit
- Fire Extinguisher
- Flashlight
- Road Emergency Flares

Thank you once again for purchasing an Adventurer LP Truck Camper. Drive safely and have a safe trip.



## TROUBLESHOOTING

### FAQ

*Q. Can I drive my truck with the slide out?*

A. No.

*Q. Can I sleep on the over cab bunk, when the camper is on the ground?*

A. Yes, for larger and slide out models. For the 76R, recommended weight limit should not exceed 500lbs.

*Q. I just emptied my black tank, but the Monitor panel shows half full?*

A. Material trapped on the sides of the holding tanks may give a false reading. Use of a spray to flush out the tank following dumping should help prevent this condition.

*Q. My unit is pre-wired for various add-ons. How do I find where the wires are located?*

A. Please contact Adventurer Service at [service@amrv.com](mailto:service@amrv.com)

*Q. How do I empty my sewage (black) tank?*

A. Both grey and black tanks have their own drainage valves, but empty through the same outlet. To drain, the black tank, connect the outlet with a sewer hose to a dumping station, and open the **large** valve for the toilet tank and let it drain. Then open the **smaller** valve to drain the grey water tank. Add clean water and a good deodorant chemical to keep tanks clean and fresh at all times. When connected to a sewer in a trailer park, the toilet holding tank valve should remain closed until the tank is almost full. Then drain and recharge black water tank as above. This method will avoid undesirable buildup in the tank.

*Q. My propane tank is full and connected properly, but my appliances are not lighting.*

A. Adventurer uses QCC-1 connections, at the cylinder valve end. The nipple has a patented Flow Limiting Device that shuts off gas flow if a leak occurs between the regulator and the appliance burner valve. It activates each time you open the cylinder valve, so be sure the appliance is turned OFF before you open the valve. If the appliance is not turned OFF when you open the valve, or if you open the propane tank valve too quickly, the Flow Limiting Device will not be able to reset and will restrict gas flow to the appliances. The QCC-1 connector is also heat sensitive, shutting off the flow of gas if it is exposed to temperatures between 240 & 300 degrees F

*Q. My Water heater is leaking at the Pressure/Temperature (PT) relief valve.*

A. Occasionally, you may experience "weeping" of the PT valve, caused by the normal expansion of water as it is heated. The tank is designed with an internal air gap at the top to reduce this weeping. In time, the heating and expansion of the water will absorb this air.

**NOTES**

---

---

---

---

---

---

---

---

---

---

---

---

---

---

---

---

---

---

---

---

---

---

---

---

---

---



Adventurer LP  
3303 W. Washington Ave., Yakima WA 98903  
Fax: 509-895-7068  
amlrv@amlrv.com  
www.amlrv.com