
DRISTEEM[®]
The humidification experts


Humidi-tech[®]





Electric Humidifier

**Installation, Operation,
and Maintenance Manual**



Warnings and cautions

 WARNING Indicates a hazardous situation that could result in death or serious injury if instructions are not followed.	CAUTION Indicates a hazardous situation that could result in damage to or destruction of property if instructions are not followed.
-------------------------------------------------------------------------------------------------------------------------------------------------------------------------------------------------------------------	-----------------------------------------------------------------------------------------------------------------------------------------------

 WARNING	
	<p>Attention installer</p> <p>Read this manual before installing, and leave this manual with product owner. This product must be installed by qualified HVAC and electrical contractors and in compliance with local, state, federal, and governing codes. Improper installation can cause property damage, severe personal injury, or death as a result of electric shock, burns, or fire.</p> <p>DRI-STEEM Technical Support: 800-328-4447</p> <p>Read all warnings and instructions</p> <p>Read this manual before performing service or maintenance procedures on any part of the system. Failure to follow all warnings and instructions could produce the hazardous situations described, resulting in property damage, personal injury, or death.</p> <p>Failure to follow the instructions in this manual can cause moisture to accumulate, which can cause bacteria and mold growth or dripping water into building spaces. Dripping water can cause property damage; bacteria and mold growth can cause illness.</p>
 	<p>Hot surfaces and hot water</p> <p>This steam humidification system has extremely hot surfaces. Water in tanks, steam pipes, and dispersion assemblies can be as hot as 212 °F (100 °C). Discharged steam is not visible. Contact with hot surfaces, discharged hot water, or air into which steam has been discharged can cause severe personal injury. To avoid severe burns, follow the cool-down procedure in this manual before performing service or maintenance procedures on any part of the system.</p>

Warnings and cautions



WARNING



Disconnect electrical power

Disconnect electrical power before installing supply wiring or performing service or maintenance procedures on any part of the humidification system. Failure to disconnect electrical power could result in fire, electrical shock, and other hazardous conditions. These hazardous conditions could cause property damage, personal injury, or death.



Contact with energized circuits can cause property damage, severe personal injury, or death as a result of electrical shock or fire. Do not remove humidifier electrical panel cover, heater terminal cover, or subpanel access panels until electrical power is disconnected.

Follow the shutdown procedure in this manual before performing service or maintenance procedures on any part of the system.



Electric shock hazard

If the humidifier starts up responding to a call for humidity during maintenance, severe bodily injury or death from electric shock could occur. To prevent such start-up, follow the procedure below before performing service or maintenance procedures on this humidifier (after the tank has cooled down and drained):

1. Use Vapor-logic®4 keypad/display to change control mode to Standby.
2. Shut off all electrical power to humidifier using field-installed fused disconnect, and lock all power disconnect switches in OFF position.
3. Close field-installed manual water supply shut-off valve.

CAUTION

Hot discharge water

Discharge water can be as hot as 212 °F (100 °C) and can damage the drain plumbing.

To prevent such damage from humidifiers without water tempering, allow the tank to cool before draining.

Humidifiers equipped with a water tempering device such as a DRI-STEEM Drane-kooler need fresh make-up water in order to function properly. Make sure the water supply to the water tempering device remains open during draining.

Excessive supply water pressure

Supply water pressure greater than 80 psi (550 kPa) can cause the humidifier to overflow.

Table of contents

ATTENTION INSTALLER

Read this manual before installing.
Leave manual with product owner.

Where to find more information

Our web site:

The following documents are available on our web site: www.dristeem.com

- Catalogs
 - Humidi-tech
 - Ultra-sorb®
- Installation, Operation, and Maintenance manuals (IOM)
 - Ultra-sorb
 - Vapor-logic4 controller (includes humidifier operation and troubleshooting)
- *DRI-STEEM Humidification System Design Guide* (includes steam loss tables and general humidification information)

Warnings and cautions ii

Overview

Product overview	
Tap/softened water	2
DI/RO water option	2
Water type conversion	2
Dispersion options	3
Capacities, electrical specifications, and weights	4
Dimensions	5

Installation

Selecting a location	
Humidifier	6
Dispersion control devices	6
Mounting the humidifier	7
Piping:	
Tap/softened water	8
DI/RO water option	9
Supply water and drain piping	10
Drane-kooler	11
Wiring	12
Humidistat and transmitter placement	14
Dispersion:	
Selecting the dispersion assembly location	15
High-efficiency Tube option	15
Interconnecting piping requirements	
Connecting to humidifier with vapor hose	16
Connecting to humidifier with tubing or pipe	17
Drip tee installation	18
SDU-I and SDU-E	
Mounting SDU-I and SDU-E	19
SDU-I: Instant, internal absorption	19
SDU-E: Higher capacity	19
SDU-E condensate drain connection	22
Mounting SDU-E	22
SDU-E rise, spread, and throw	23
Single tube	24
Rapid-sorb	
Pitch requirements	27
Header outside of duct, horizontal airflow	28
Header inside of duct, horizontal airflow	30
Steam supply connections to Rapid-sorb header	32
Condensate drain connections to Rapid-sorb header	32
Ultra-sorb	32

Table of contents

Operation

Start-up procedure	33
Start-up checklist.....	34

Maintenance

Tap/softened water	
Water quality and maintenance.....	35
Skim duration.....	35
Cool down humidifier.....	36
Inspection and maintenance.....	36
Off-season shut-down procedure	39
DI/RO water option	
Cool down humidifier.....	40
Inspection and maintenance.....	40
Off-season shut-down procedure	41

Replacement parts

Humidifier	42
SDU-E.....	44
SDU-I	45
Subpanel	46

Warranty	Back cover
----------------	------------

Keypad/display and troubleshooting

The *Vapor-logic4 Installation and Operation Manual*, which was shipped with your humidifier, is a comprehensive operation manual. Refer to it for information about using the keypad/display and Web interface, and for troubleshooting information.

Download DRI-STEEM literature

Most DRI-STEEM product manuals can be downloaded, printed, and ordered from our web site: www.dristeem.com

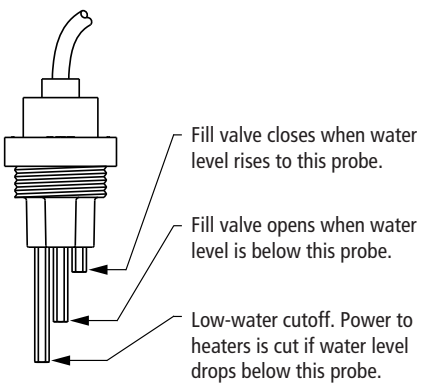
Product overview

Notes:

See Pages 8 and 9 for detailed installation drawings.

Damage caused by chloride corrosion is not covered by your DRI-STEEM warranty.

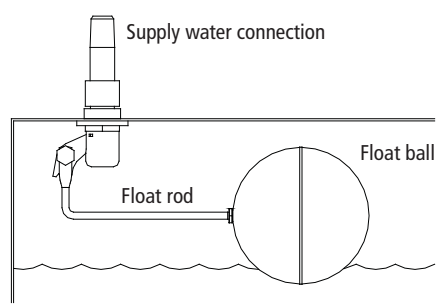
**Figure 2-1:
Water level control for tap/softened water humidifier**



Humidifiers using tap or softened water control water levels electronically using a three-rod probe. The controller responds with the above actions when the water level reaches each rod.

VLC-OM-030

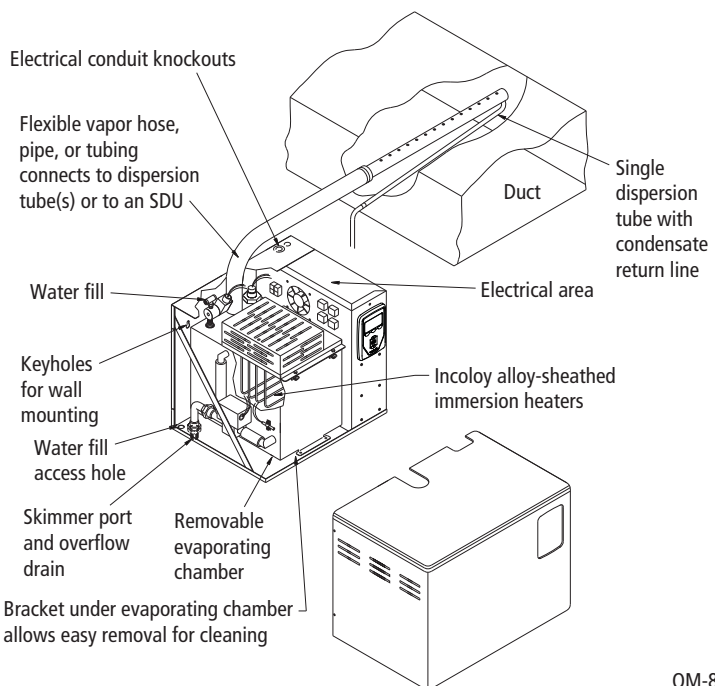
**Figure 2-2:
Water level control for DI/RO water option humidifier**



Humidifiers using DI/RO water control water levels using a float valve and low-water cutoff switch.

OM-7396

**Figure 2-3:
Installation overview (Humidi-tech for tap/softened water shown)**



OM-82-4

Tap/softened water

Humidi-tech humidifiers with tap/softened water (shown above) use electricity to heat tap or softened fill water into steam for humidification. A conductivity probe monitors the water level; therefore, water conductivity must be at least 30 $\mu\text{S}/\text{cm}$ for proper operation. Humidi-tech with tap/softened water will not operate with DI/RO water. For DI/RO water, use Humidi-tech with the DI/RO water option.

DI/RO water option

Humidi-tech humidifiers with DI/RO water systems (systems using deionized water or water that has been treated using reverse osmosis) use electricity to heat DI/RO fill water into steam for humidification. Water level is controlled with a float valve and low water cutoff switch. Float valves are compatible with DI/RO water only.

Humidifiers with the DI/RO water option are virtually maintenance free and require little or no downtime.

Water type conversion

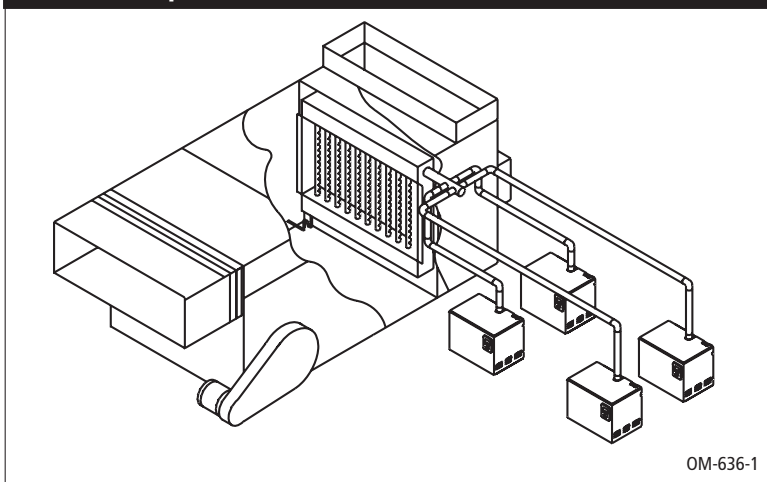
Humidi-tech tap/softened water humidifiers can be converted in the field for use with DI/RO water, and Humidi-tech DI/RO water humidifiers can be converted in the field for use with tap/softened water. Contact your DRI-STEEM representative or distributor for parts and instructions.

Product overview

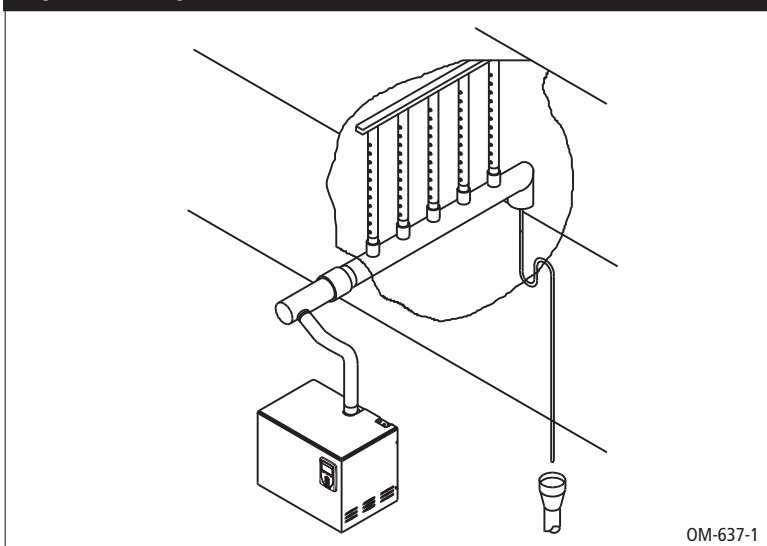
Dispersion options

In addition to single tube dispersion, shown in Figure 2-3, the dispersion options shown on this page are available for Humidi-tech humidifiers. See the installation instructions beginning on Page 19.

**Figure 3-1:
Ultra-sorb dispersion**

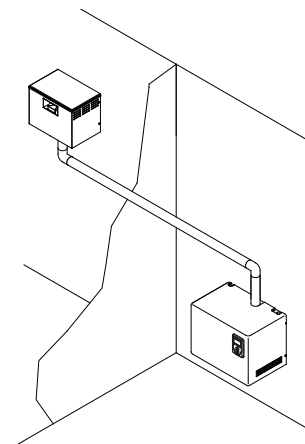


**Figure 3-2:
Rapid-sorb dispersion**



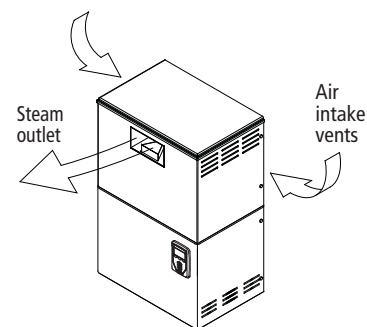
**Figure 3-3:
SDU mounting options**

Remote from humidifier



OM-56-1

Directly above humidifier



OM-55-1

Capacities, electrical specifications, and weights

Table 4-1:
Humidi-tech electrical specifications, capacities and weights

HT model	Single-phase 230V		Three-phase 400V		Shipping weight (kg)	Operating weight (kg)
	kW	Steam capacity (kg/h)	I max. (A)	Steam capacity (kg/h)		
2	2.5	8.0	—	—	37	44
4	5.0	16.0	5.4	8.7*	37	44
6	7.5	24.0	8.2	13.0*	41	56
8	10.0	31.9	10.9	17.3*	41	56
10	12.5	39.9	13.6	15.2*	43	64
12	15.0	47.9	16.3	17.3	43	64
14	—	—	19.1	20.2	43	64
16	—	—	21.8	23.1**	43	64
21	—	—	28.6	30.3**	44	70
25	—	—	34.0	36.1**	44	70
30	—	—	40.8	43.3**	47	72
34	—	—	46.3	49.1**	47	72

* For wire sizing, the highest leg draw is shown due to current imbalance.

** No available SDU option for these models.

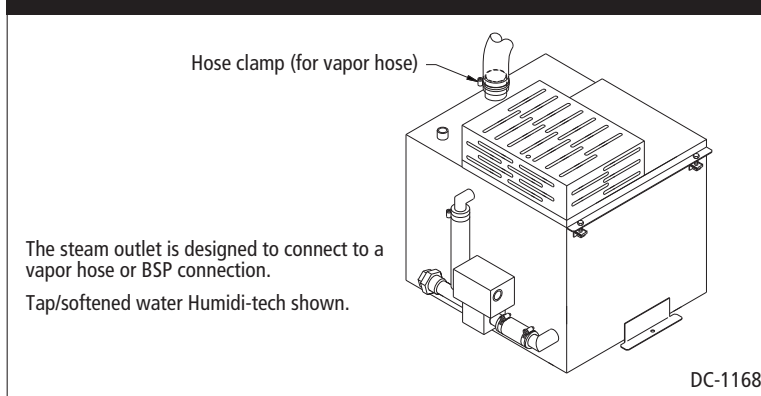
Notes:

- SDU-I is available for Models HT-2 through HT-10.
- SDU-E is available for all models, except Model HT-2 and Models HT-16 through HT-34.
- Models with the SDU option have additional electronic components in the Humidi-tech cabinet. If adding an SDU, add the following to the Humidi-tech shipping and operating weights:
SDU-E: 5.5 kg
SDU-I: 4.0 kg
- All Humidi-tech humidifiers operate at 50/60 Hz.
- SDUs ship separate from the Humidi-tech.

Table 4-2:
Steam connection sizes

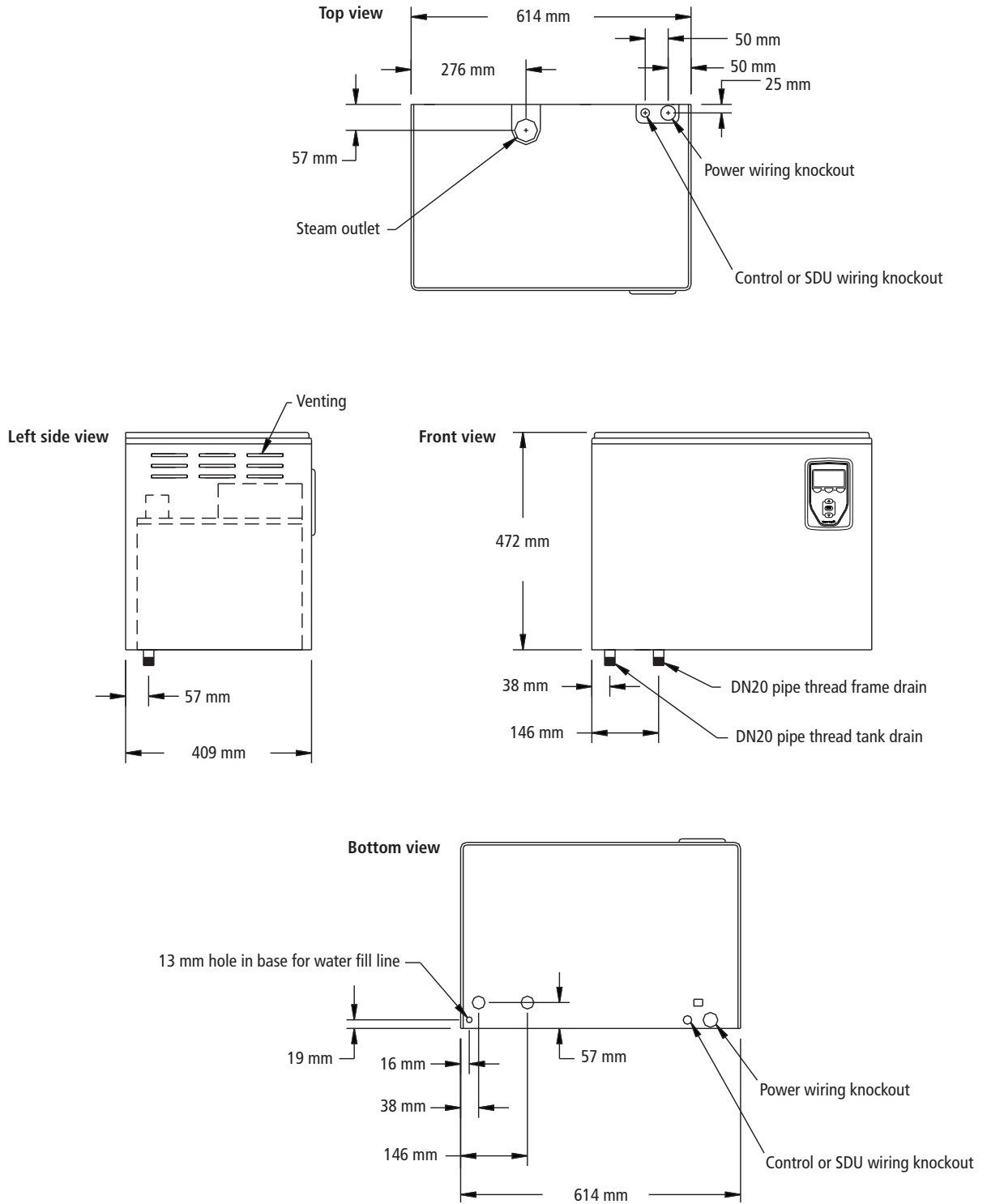
HT model	Steam outlet
2, 4, 6, 8	1 ½" hose or BSP connection
10*, 12*, 14*, 16*	1 ½" or 2" hose or BSP connection
21, 25, 30, 34	2" hose or BSP connection
* If using with an SDU-E (Space Dispersion Unit External Absorption), the Humidi-tech steam outlet must be 2" to match the SDU-E steam inlet.	

Figure 4-1:
Steam outlet connections



Dimensions

**Figure 5-1:
Humidi-tech dimensions**



DC-1167

Selecting a location

Humidifier

When selecting a location for the humidifier, consider the following:

- **Proximity to the duct**

Install the humidifier near the air duct system where the dispersion assembly will be located. The maximum recommended length for steam hose connecting a single humidifier to a dispersion assembly is 3 m. The maximum recommended developed length for tubing or pipe connecting a single humidifier to a dispersion assembly is 6 m.

For more information about installing dispersion assemblies, see “Dispersion,” beginning on Page 15.

- **Elevation of the installed dispersion assembly**

The recommended installation location for the dispersion assembly is at an elevation higher than the humidifier. However, if the dispersion assembly must be installed at an elevation lower than the humidifier, install a drip tee and drain. See “Drip tee installation” on Page 18.

Before installing a dispersion assembly or interconnecting piping, review all pitch requirements in the “Dispersion” section of this manual.

- **Required clearances** (see Figure 7-1)

- **Electrical connections**

Electrical power supply connections are at the lower or upper right rear corner of the unit. See “Wiring” on Pages 12 and 13.

- **Supply water and drain piping connections**

Water supply piping and drain connections are at the lower left rear corner of the unit. See the piping illustrations and instructions starting on Page 8.

- **Exterior wall insulation**

Install the humidifier on an exterior wall only if the wall is properly insulated.

Dispersion control devices

See Figure 14-1 for recommended installation locations for the dispersion assembly and associated control devices.

Mounting the humidifier

Follow the instructions below for your wall type, and mount the humidifier level and plumb. See Figures 8-1 and 9-1.

- Wood studs 16" (406 mm) on center:
Mark hole locations at the centers of the studs, and predrill $\frac{1}{4}$ " (6 mm) diameter pilot holes. Secure the cabinet to the wall with the lag bolts (provided).
- Metal studs 16" (406 mm) on center:
Mark hole locations at centers of studs, and drill $\frac{3}{8}$ " (10 mm) holes through the studs and wall. Push a $\frac{3}{8}$ " (10 mm) bolt through the wall, the studs, and a backing plate on the other side of the wall. Secure the cabinet to the wall with a nut and washer.
- If 16" (406 mm) on-center studs are not available:
Mount spanner boards on the wall, spanning two studs. Locate one board at the top of the cabinet (for the lag bolts) and the other board 3" (76 mm) on center from the bottom of the cabinet. Secure the cabinet to the spanner boards.
- Hollow block or poured concrete wall:
Mark hole locations, and drill appropriate pilot holes for two $\frac{3}{8}$ " (10 mm) toggle bolts or two $\frac{3}{8}$ " (10 mm) machine bolt lead anchors. Secure the cabinet in place with the bolts and anchors.

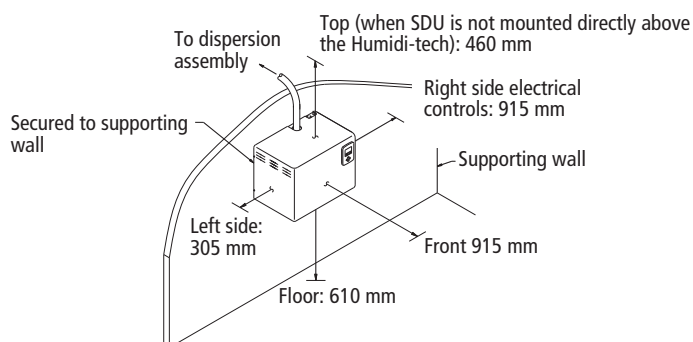
WARNING

Mounting hazard

Mount humidifier per the instructions in this manual and to a structurally stable surface. Improper mounting of the humidifier can cause it to fall or tip, resulting in severe personal injury or death.

Figure 7-1:
Humidi-tech clearance recommendations

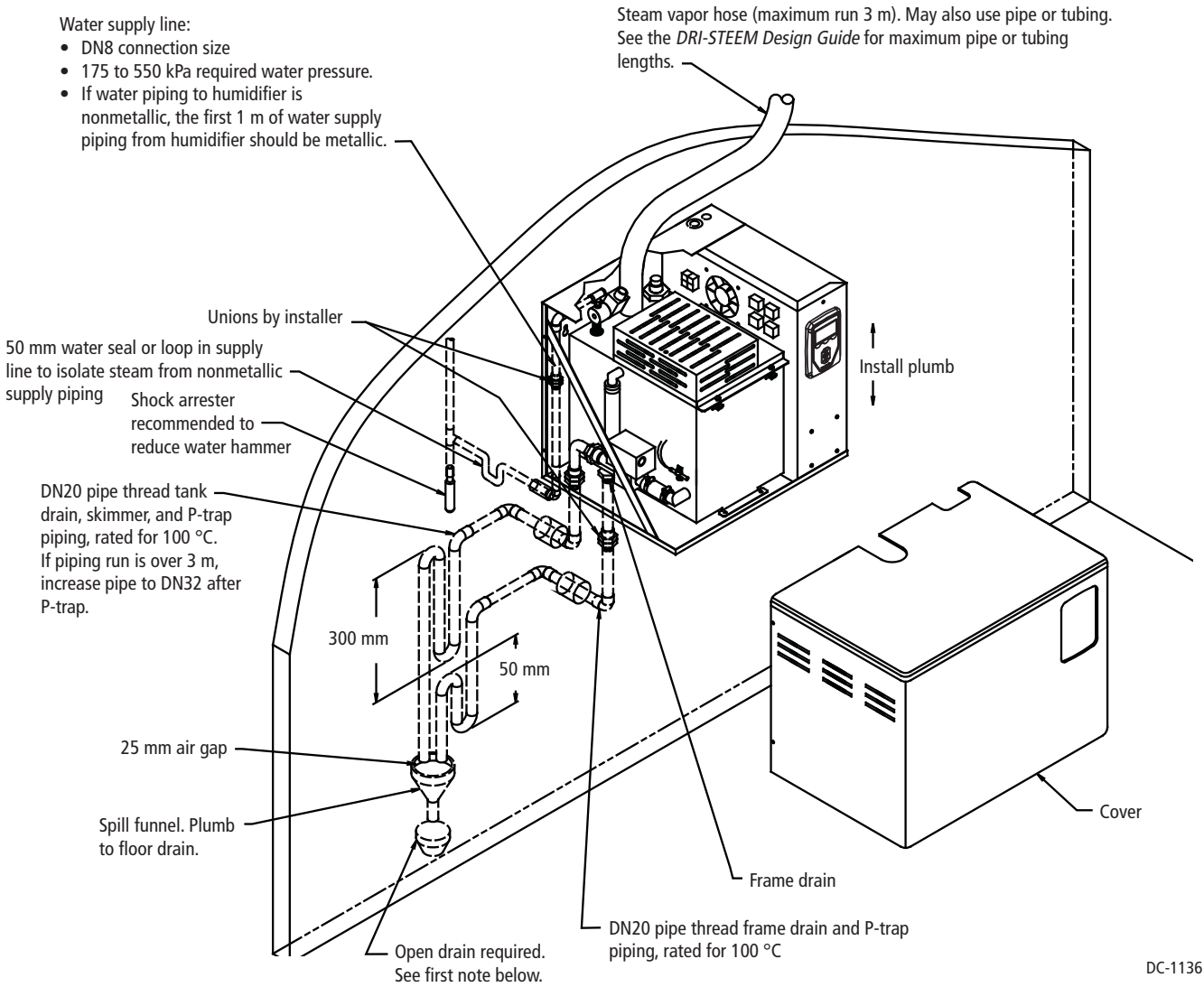
Maintain these clearances for service and maintenance.



DC-1201

Piping: Tap/softened water

**Figure 8-1:
Humidi-tech (tap/softened water) field piping overview**

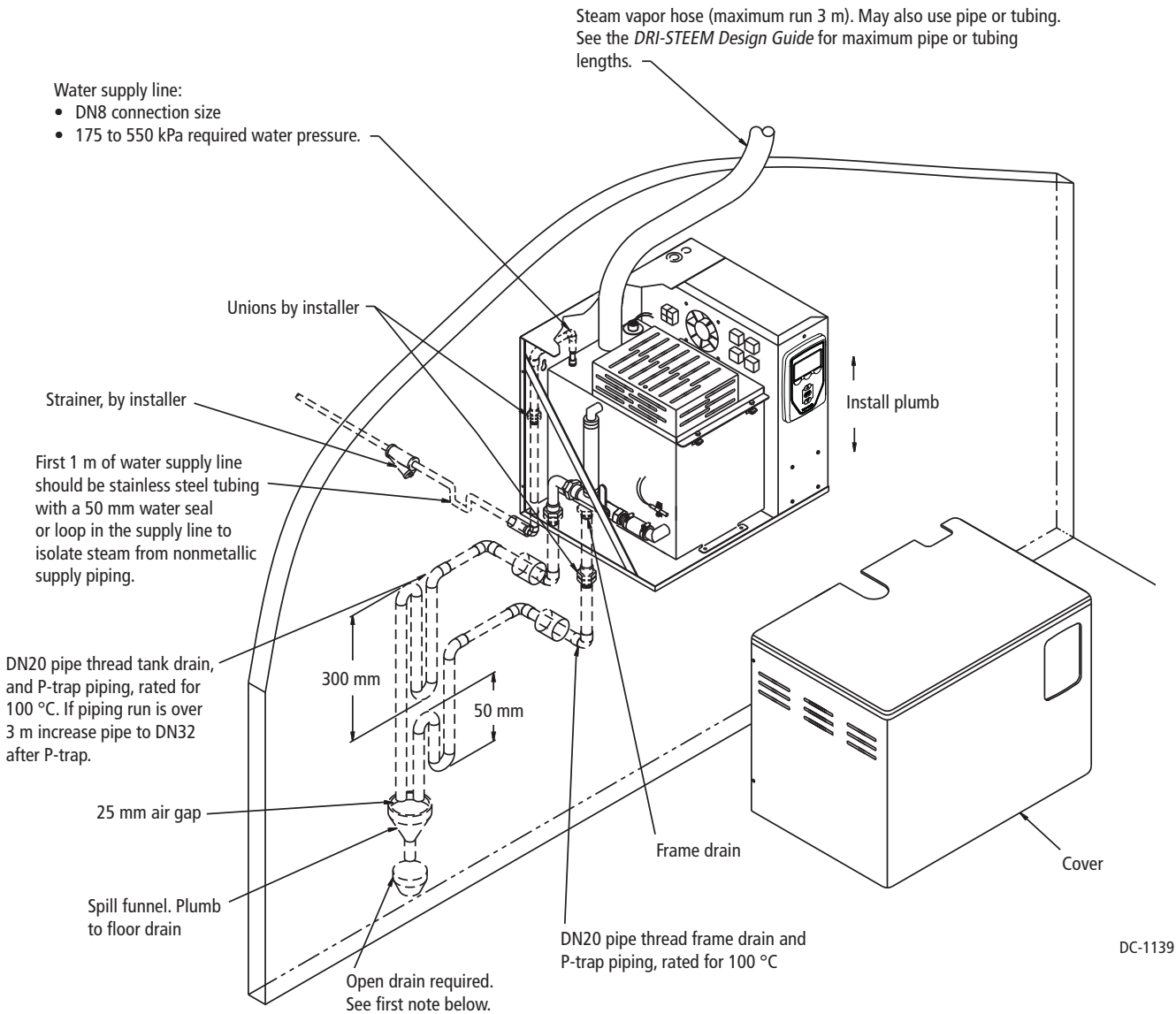


Notes:

- Locate air gap only in spaces with adequate temperature and air movement to absorb flash steam; otherwise, condensation may form on nearby surfaces. Refer to governing codes for drain pipe size and maximum discharge water temperature.
- Offset humidifier from spill funnel or floor drain to prevent flash steam from rising into cabinet.
- Dashed lines indicate provided by installer.
- Water supply inlet is more than 25 mm above skim/overflow port, eliminating the possibility of backflow or siphoning from tank. No additional backflow prevention is required; however, governing codes prevail.
- Install a union in water supply and drain lines as shown to allow tank removal.
- Damage caused by chloride corrosion is not covered by your DRI-STEEM warranty.

Piping: DI/RO water option

**Figure 9-1:
Humidi-tech (DI/RO water option) field piping overview**



Notes:

- Locate air gap only in spaces with adequate temperature and air movement to absorb flash steam; otherwise, condensation may form on nearby surfaces. Refer to governing codes for drain pipe size and maximum discharge water temperature.
- Offset humidifier from spill funnel or floor drain to prevent flash steam from rising into the cabinet.
- Dashed lines indicate provided by installer.
- The water supply inlet is more than 25 mm above the overflow port, eliminating the possibility of backflow or siphoning from the tank. No additional backflow prevention is required; however, governing codes prevail.
- Install a union in the water supply and drain lines as shown to allow tank removal.
- Damage caused by chloride corrosion is not covered by your DRI-STEEM warranty.

DC-1139

Piping: Supply water and drain piping

CAUTION

Hot discharge water

Discharge water can be as hot as 212 °F (100 °C) and can damage the drain plumbing.

To prevent such damage from humidifiers without water tempering, allow the tank to cool before draining.

Humidifiers equipped with a water tempering device such as a DRI-STEEM Drane-kooler need fresh make-up water in order to function properly. Make sure the water supply to the water tempering device remains open during draining.

Excessive supply water pressure

Supply water pressure greater than 80 psi (550 kPa) can cause the humidifier to overflow.

Supply water piping may be of any code-approved material (copper, steel, or plastic). The fill valve connection size is a DN10 pipe thread fitting. In cases where water hammer may be a possibility, consider installing a shock arrester. Water pressure must be between 175 kPa and 550 kPa.

If water piping to humidifier is nonmetallic, we recommend that the first 1 m of water supply piping from the humidifier be metallic with a 50 mm water seal or loop in the supply line to isolate steam from nonmetallic supply piping.

Drain piping may be of any code-approved material (copper, steel, or plastic rated for 100 °C minimum). If drainage by gravity is not possible, use a reservoir pump rated for 100 °C water.

The final connection size is DN20 copper for the tank and frame drains. Do not reduce this connection size. Pipe the tank and frame drains separately, as shown in Figures 8-1 and 9-1, to prevent backflow of drain water into the humidifier cabinet.

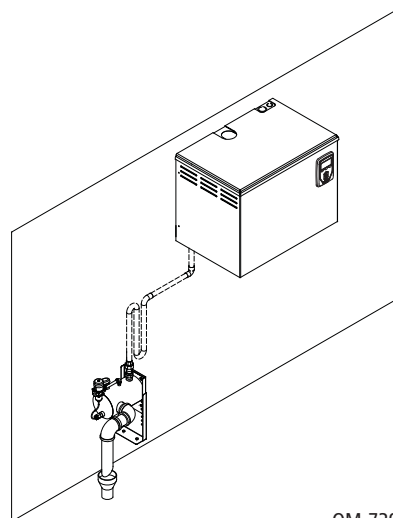
If the equivalent length of pipe from the humidifier drain to the plumbing system drain is more than 3 m, increase the pipe size to DN32.

See Figures 8-1 and 9-1 for more piping instructions.

Important: Install unions in the water supply and drain lines as shown in Figures 8-1 and 9-1 to allow tank removal.

Figure 10-1:
Drane-kooler water tempering device

DRI-STEEM's Drane-kooler, shown mounted to a humidifier, tempers discharged water. For other Drane-kooler mounting options or for more information, contact your DRI-STEEM representative/distributor, or view the Drane-kooler product data sheet in the literature section at www.dristeem.com



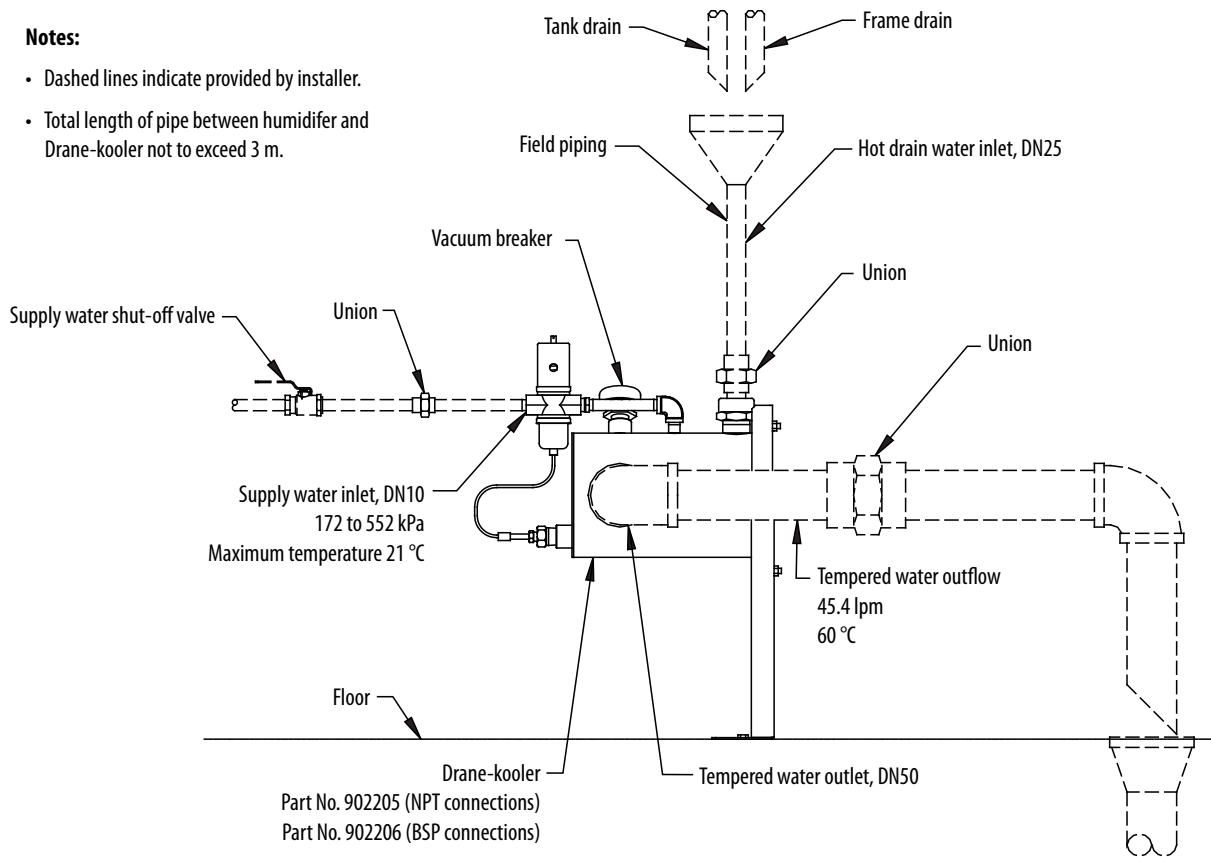
OM-7398

Piping: Drane-kooler

**Figure 11-1:
Drane-kooler field piping connections**

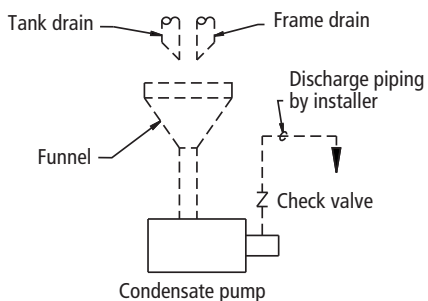
Notes:

- Dashed lines indicate provided by installer.
- Total length of pipe between humidifier and Drane-kooler not to exceed 3 m.



DC-1160

**Figure 11-2:
Lifting drain water**



Note:
Use a condensate pump rated for your application. Pumps are rated by fluid temperature, head (pressure), and flow (gpm). Contact your local DRI-STEEM representative for pump selection.

DC-1138

Wiring

⚠ WARNING

Electric shock hazard

Only qualified electrical personnel should perform field wiring installation procedures. Improper wiring or contact with energized circuits can cause property damage, severe personal injury, or death as a result of electric shock and/or fire.

Do not remove the humidifier electrical panel cover or the heater terminal cover until electrical power is disconnected. Contact with energized circuits can cause property damage, severe personal injury, or death as a result of electrical shock.

Humidifier field wiring

All wiring must be in accordance with all governing codes, and with the humidifier wiring diagrams. The diagrams are located inside the removable subpanel cover on the right side of the humidifier cabinet. Power supply wiring must be rated for 105 °C.

When selecting a location for installing the humidifier, avoid areas close to sources of electromagnetic emissions such as power distribution transformers.

The fill valve, drain valve, probes, and temperature sensors use Class 2, 24 VAC power.

The use of semiconductor fusing sized per IEC 60364 is recommended.

Grounding requirements

The approved earth ground must be made with solid metal-to-metal connections and must be a good conductor of radio frequency interference (RFI) to earth (multistranded conductors).

Ground wire should be the same mm² size as the power wiring or sized per IEC 60364 requirements.

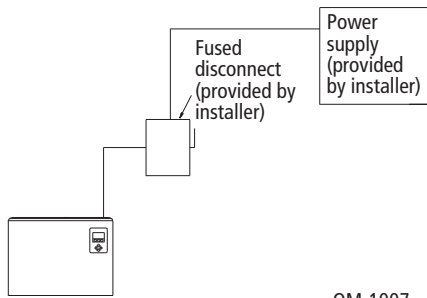
Proper wiring prevents electrical noise.

Electrical noise can produce undesirable effects on electronic control circuits, which affects controllability. Electrical noise is generated by electrical equipment such as inductive loads, electric motors, solenoid coils, welding machinery, or fluorescent light circuits. The electrical noise or interference generated from these sources (and the effect on controllers) is difficult to define, but the most common symptoms are erratic control or intermittent operational problems.

Important:

- For maximum EMC (electromagnetic compatibility) effectiveness, wire all humidity, high limit, and airflow controls using multicolored shielded/screened plenum-rated cable with a drain wire for the shield/screen. Connect the drain wire to the shield/screen ground terminal with wire less than 50 mm in length.
- Do not ground shield at the device end.

Figure 12-1:
Field wiring requirements



OM-1007

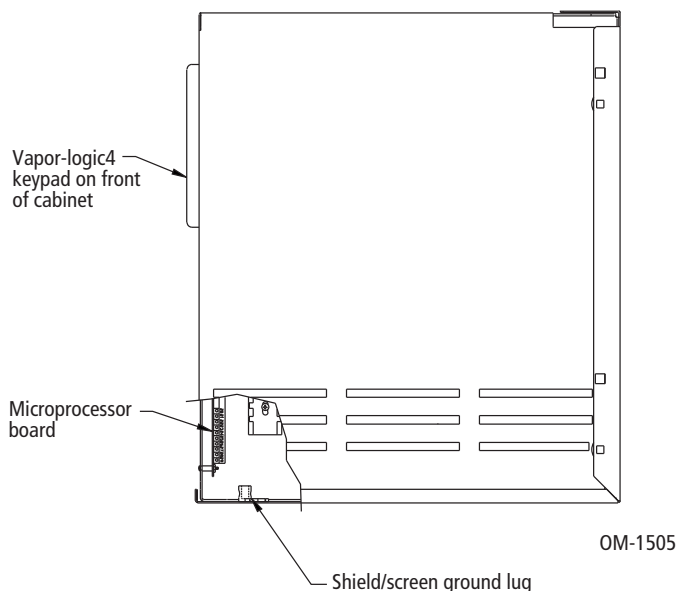
Notes:

- Control wiring and power wiring must be run in dedicated or separate earthed metal conduit, cable trays, or trunking.
- Separate the line voltage wiring from low voltage control circuit wiring when routing electrical wiring inside the humidifier cabinet.
- Do not use chassis or safety grounds as current-carrying commons. Never use a safety ground as a conductor or neutral to return circuit current.

Wiring

Figure 13-1:
Shielded/screened cable drain wire connection to lug

Humidifier side view



Note:
For maximum EMC effectiveness, all humidity, temperature, and airflow controls should be wired using multicolored shielded/screened plenum-rated cable with a drain wire for the shield/screen. The drain wire should be connected to the shield/screen ground terminal with its length kept to less than 2" (50 mm).

Table 13-2:
European breaker requirements

I max. A	Breaker size
0 - 8.0	10
8.1 - 10.4	13
10.5 - 12.8	16
12.9 - 16	20
16.1 - 20	25
20.1 - 25.6	32
25.7 - 32	40
32.1 - 40	50
40.1 - 50.4	63
50.5 - 64	80
64.1 - 80	100
80.1 - 100	125
100.1 - 128	160
128.1 - 160	200

Table 13-1:
European wiring requirements

230 volt single phase			400 volt three phase		
Amps	Wire size mm ²	Ground wire size mm ²	Amps	Wire size mm ²	Ground wire size mm ²
0 - 18	2.5	2.5	0 - 15.7	2.5	2.5
18.1 - 24	4	4	15.8 - 21	4	4
24.1 - 30.7	6	6	21.1 - 27	6	6
30.8 - 42.7	10	10	27.1 - 37.5	10	10
42.8 - 57	16	16	37.6 - 51	16	16
57.1 - 75.7	25	16	51.1 - 66.7	25	16
75.8 - 93.7	35	16	66.8 - 82.5	35	16
93.8 - 113.2	50	25	82.6 - 100.5	50	25
113.3 - 144	70	35	100.6 - 128.2	70	35
144.1 - 174	95	50	128.3 - 155.2	95	50
174.1 - 201.7	120	70	155.3 - 179.2	120	70

Humidistat and transmitter placement

Other factors affecting humidity control

Humidity control involves more than the controller's ability to control the system. Other factors that play an important role in overall system control are:

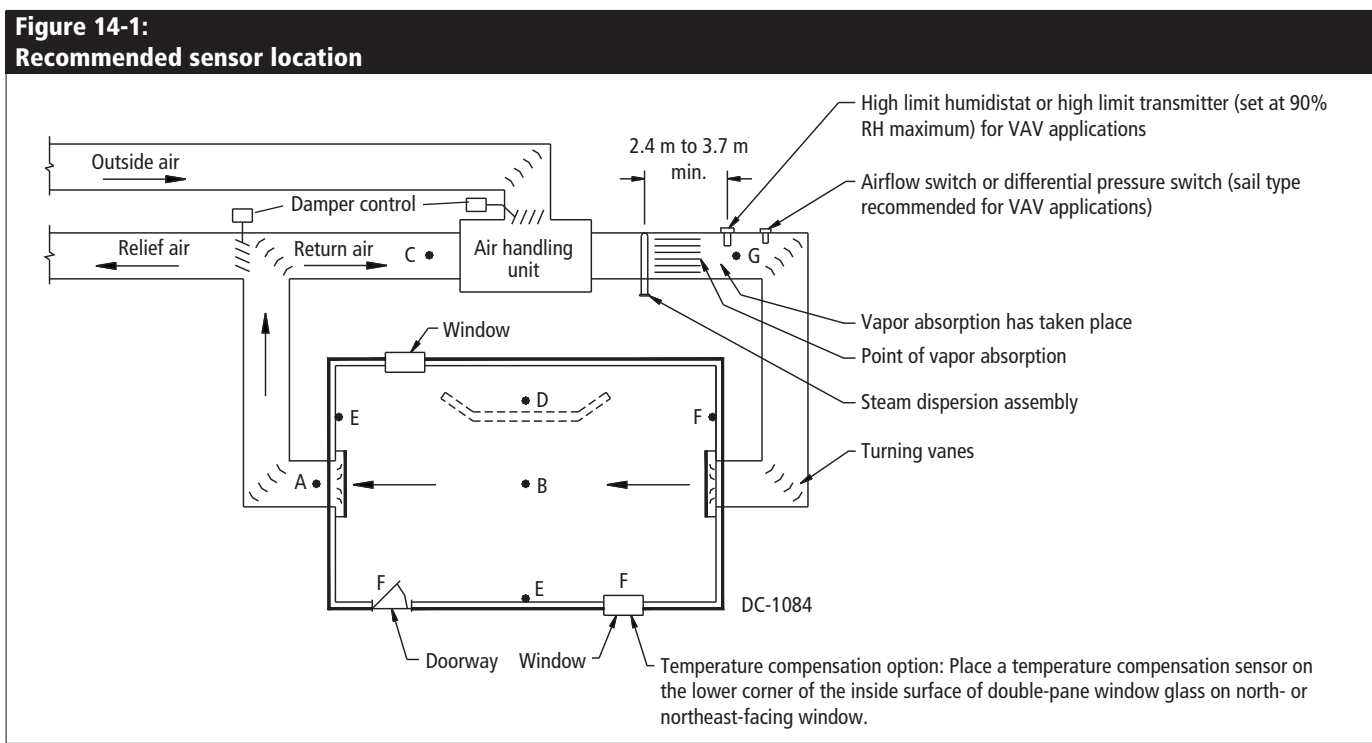
- Size of humidification system relative to load
- Overall system dynamics associated with moisture migration time lags
- Accuracy of humidistats and humidity transmitters and their location
- Dry bulb temperature accuracy in space or duct
- Velocities and airflow patterns in ducts and space environments
- Electrical noise or interference

Humidistat and sensor locations are critical

Humidistat and sensor location have a significant impact on humidifier performance. In most cases, do not interchanging duct and room humidity devices. Room humidity devices are calibrated with zero or little airflow; whereas duct humidity devices require air passing across them.

Recommended sensor locations (see figure below):

- A** Ideal. Ensures the best uniform mix of dry and moist air with stable temperature control.
- B** Acceptable, but room environment may affect controllability, such as when sensor is too close to air grilles, registers, or heat radiation from room lighting.
- C** Acceptable. Provides uniform mixture of dry and moist air. If extended time lag exists between moisture generation and sensing, extend sampling time.
- D** Acceptable (behind wall or partition) for sampling entire room if sensor is near an air exhaust return outlet. Typical placement for sampling a critical area.
- E** Not acceptable. These locations may not represent actual overall conditions in the space.
- F** Not acceptable. Do not place sensors near windows, door passageways, or areas of stagnant airflow.
- G** Best sensing location for a high-limit humidistat or humidity transmitter and airflow proving switch.



Dispersion: Selecting the dispersion assembly location

DRI-STEEM humidifiers operate with several types of dispersion assemblies for open spaces and for ducts and air handling units.

Dispersion assemblies in ducts and air handling units must be positioned where the water vapor being discharged is carried off with the airstream and is absorbed before it can cause condensation or dripping.

- For each dispersion device, DRI-STEEM documents distances required for non-wetting to occur. For more information about absorption non-wetting distances, see the non-wetting tables in this humidifier's product catalog, available for viewing, printing or ordering at www.dristeem.com.
- In general, the dispersion assembly is best placed where the air can absorb the moisture being added without causing condensation at or after the unit. This normally will be after the heating coil or where the air temperature is highest.
- Place the dispersion assembly such that absorption will occur
 - before the intake of a high efficiency filter, because the filter can remove the visible moisture and become waterlogged;
 - before coming in contact with any metal surface;
 - before fire or smoke detection devices;
 - before a split in the duct; otherwise, the dispersion assembly can direct more moisture into one duct than the other.
- When draining dispersion condensate to an open drain, provide a 1" (25 mm) air gap between the condensate drain piping and the drain. Locate the gap only in spaces with adequate temperature and air movement to absorb flash steam; otherwise, condensation may form on nearby surfaces.

Figure 15-1:
Ultra-sorb with the High-efficiency Tube option



High-efficiency Tube option

Dispersion assemblies with the High-efficiency Tube option are designed to produce significantly less dispersion-generated condensate and airstream heat gain, which reduces wasted energy by up to 85%. These improvements are accomplished by reducing the thermal conductivity of the tubes with 1/8" of polyvinylidene fluoride (PVDF) insulating material on the outside of the tubes. These assemblies require careful unpacking, installation, and handling. If your dispersion assembly has the High-efficiency Tube option, be sure to read this section carefully.

Dispersion: Interconnecting piping requirements

Important:

Failure to follow the recommendations in this section can result in excessive back pressure on the humidifier. This will result in unacceptable humidification system performance such as leaking gaskets, blown water seals, erratic water level control, and spitting condensate from the dispersion tube.

Important:

Reducing the inside diameter of the interconnecting piping will result in the internal humidifier system pressure exceeding the parameters for acceptable performance.

The steam outlet on the humidifier is sized to the output of the humidifier. DO NOT use vapor hose or interconnecting tubing/piping with an inside diameter smaller than the humidifier steam outlet. See note at left.

- See maximum steam carrying capacities in Table 16-1.
- If the humidifier must be located higher than the dispersion assembly, use the recommend installation shown in Figure 18-1.

Connecting to humidifier with vapor hose

- Support vapor hose to prevent sags, or low spots, and to maintain a minimum pitch of 15% back to the humidifier.
- Use DRI-STEEM vapor hose. Other manufacturers of vapor hose may use unacceptable release agents or material mixes that can affect humidifier system performance adversely. Using hose from alternative manufacturers increases the possibility of tank foaming and accelerated aging. Foaming causes condensate discharge at the dispersion assembly.
- Do not use vapor hose in outdoor applications.
- Do not insulate vapor hose. Insulation causes accelerated heat aging, causing the vapor hose to become hard and susceptible to failure due to cracks.
- For single tube applications, see hose kit sizes in Table 25-1.

Table 16-1:
Maximum steam carrying capacity and length of interconnecting vapor hose, tubing and pipe*

Vapor hose			Copper or stainless steel tubing and Schedule 40 steel pipe		
Hose I.D.	Maximum capacity	Maximum length**	Tube or pipe size***	Maximum capacity	Maximum developed length†
DN40	68 kg/h	3 m	DN40	68 kg/h	6.1 m
DN50	113 kg/h	3 m	DN50	100 kg/h	9.2 m

* Based on total maximum pressure drop in hose, tubing or piping of 1250 Pa
 ** Maximum recommended length for vapor hose is 3 m. Longer distances can cause kinking or low spots.
 *** To minimize loss of capacity and efficiency, insulate tubing and piping.
 † Developed length equals measured length plus 50% of measured length, to account for pipe fittings.

Dispersion: Interconnecting piping requirements

Connecting to humidifier with tubing or pipe

- See Figures 24-1 and 25-1 for interconnecting tubing and pipe pitch requirements for single tube applications. See Table 27-1 for interconnecting tubing and pipe pitch requirements for Rapid-sorb applications.
- Support interconnecting piping between the humidifier steam outlet and the dispersion system with pipe hangers. Failure to properly support the entire steam piping weight may cause damage to the humidifier tank and void the warranty.
- Steam supply adapters are available from DRI-STEEM. These adapters convert a tubing outlet on the humidifier to threaded pipe, allowing a pipe connection.
- 90° elbows are not recommended; use two 45° elbows, 0.3 m apart.
- Thin wall tubing heats up faster and causes less start-up loss than heavy wall pipe.
- Insulating hard pipe reduces the loss in output caused by condensation.
- When using hard pipe, take care to remove ALL traces of lubricants used to thread the pipe. This will minimize the possibility of tank foaming. Denatured alcohol or mineral spirits work best for removing lubricant.

 **WARNING**

Excessive moisture hazard

DRI-STEEM strongly recommends installing a duct airflow proving switch and a duct high limit humidistat. These devices prevent a humidifier from making steam when there is low airflow in the duct or when the RH level in the duct is too high. Failure to install these devices can result in excessive moisture in the duct, which can cause bacteria and mold growth or dripping through the duct.

**Table 17-1:
Steam loss of interconnecting vapor hose, tubing and pipe**

Description	Nominal hose, tubing or pipe size	Steam loss		Insulation thickness
		Noninsulated	Insulated	
Hose	DN40	0.22 kg/h/m	N/A	N/A
	DN50	0.30 kg/h/m	N/A	N/A
Tubing	DN40	0.164 kg/h/m	0.03 kg/h/m	50 mm
	DN50	0.21 kg/h/m	0.037 kg/h/m	50 mm
Pipe	DN40	0.33 kg/h/m	0.03 kg/h/m	50 mm
	DN50	0.38 kg/h/m	0.037 kg/h/m	50 mm

Note: These data are based on an ambient air temperature of 27 °C, fiberglass insulation, copper tubing, and Schedule 40 pipe.

Dispersion: Drip tee installation

⚠ WARNING

Hot surface and steam hazard

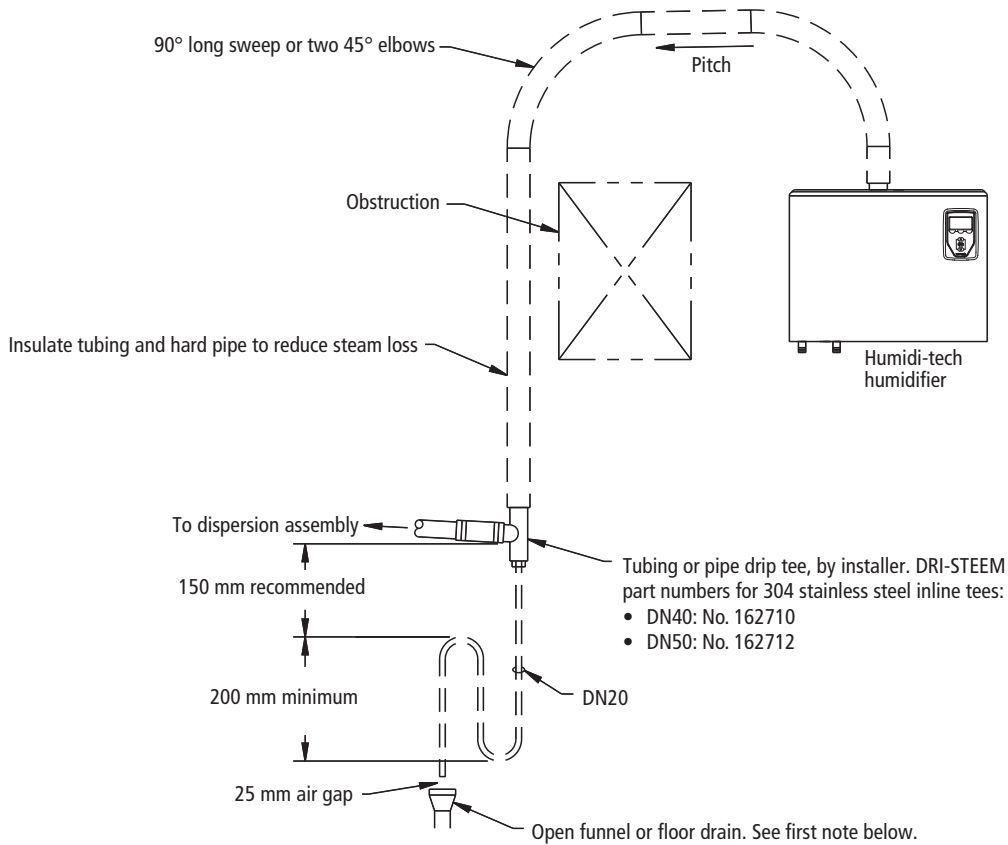
Dispersion tube, steam hose, tubing, or hard pipe can contain steam, and surfaces can be hot. Discharged steam is not visible. Contact with hot surfaces or air into which steam has been discharged can cause severe personal injury.

Drip tee installation

Install a drip tee as shown below when the humidifier is mounted higher than the dispersion assembly, when interconnecting hose or piping needs to go over an obstruction, or when interconnecting piping runs are long.

Important: Vapor hose must be supported to prevent sagging or low spots.

**Figure 18-1:
Drip tee installation**



Notes:

- Locate air gap only in spaces with adequate temperature and air movement to absorb flash steam; otherwise, condensation may form on nearby surfaces. Refer to governing codes for drain pipe size and maximum discharge water temperature.
- Support steam hose so there are no sags or low spots.
- Dashed lines indicate provided by installer.

DC-1450

Dispersion: SDU-I and SDU-E

SDU-I is available for Models HT-2 through HT-10.

SDU-E is available for all models, except Model HT-2 and HT-16 through HT-34.

Note: SDUs ship separate from the Humidi-tech.

Mounting SDU-I and SDU-E

Both SDUs can be mounted on a wall directly above the humidifier cabinet or mounted on a wall remote from the humidifier (see Figure 20-3). Use the mounting template on the box for correct placement. Two lag bolts are provided with each SDU.

- Installation must comply with governing codes.
- See interconnecting piping requirements in Table 16-1, and the drip tee installation instructions on Page 18.
- Provide at least 150 mm clearance on each side of the SDU.
- Field wiring is required to connect the SDU fan and airflow proving switch terminals to Humidi-tech electrical panel terminals. Refer to the external connections diagram in the package shipped with your unit. See Figure 19-1. Minimum wire size for field wiring is 1.5 mm² stranded wire.
- For wall mounting, use the mounting template on the box for correct placement. Two M10 × 50 mm coach screws are provided with each fan unit.
- When mounting on a stud wall (studs 16" [406 mm] on center), locate studs and position lag bolts (coach screws) in place so that each of the two lag bolts (coach screws) centers on a stud. Mark hole locations and predrill 6 mm diameter pilot holes for an M10 × 50 mm coach screw.
- For hollow block or poured concrete wall mounting, position template in place and mark the holes. Drill appropriate pilot hole for two M10 toggle bolts or two M10 machine bolt lead anchors (expansion bolts). Secure SDU frame in place.

When performing Humidi-tech maintenance

If the SDU-E or SDU-I is installed immediately above the Humidi-tech, disconnect both hose clamps on the steam hose, grip the hose and rotate it to break it loose from the tubing, and then slide the hose up onto the SDU steam tube until sufficient clearance is provided to move the tank.

SDU-I: Instant, internal absorption

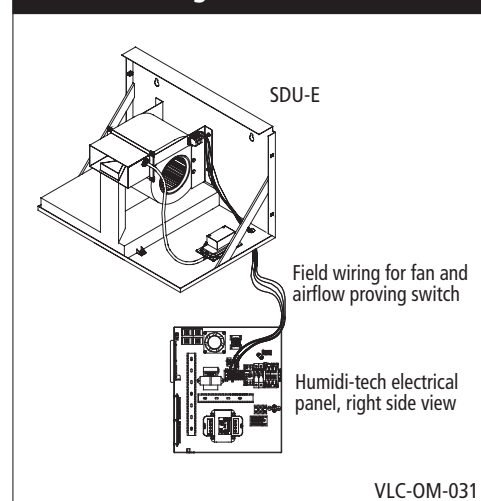
SDU-I (Space Distribution Unit Internal Absorption) disperses humidity with no visible vapor trail or wetness, making it ideal for use in finished spaces. The SDU-I fan mixes room air and steam to ensure complete absorption before discharge as humidified air.

Important: For visible vapor to be absorbed completely within the SDU-I unit before being discharged as humidified air, room air must be 45% RH or less. Trying to maintain greater than 45% RH will cause visible vapor and potential for moisture collection on the discharge grille.

SDU-E: Higher capacity

SDU-E (Space Distribution Unit External Absorption) is designed for higher capacity dispersion. SDU-E requires an installed condensate drain line and water seal, provided by installer.

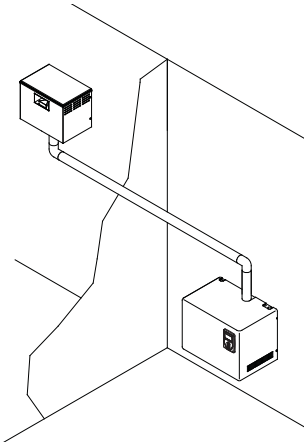
Figure 19-1:
SDU field wiring



Dispersion: SDU-I and SDU-E

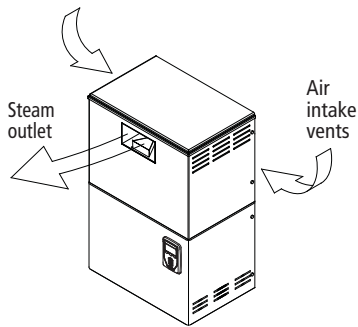
**Figure 20-3:
SDU mounting options**

Remote from humidifier



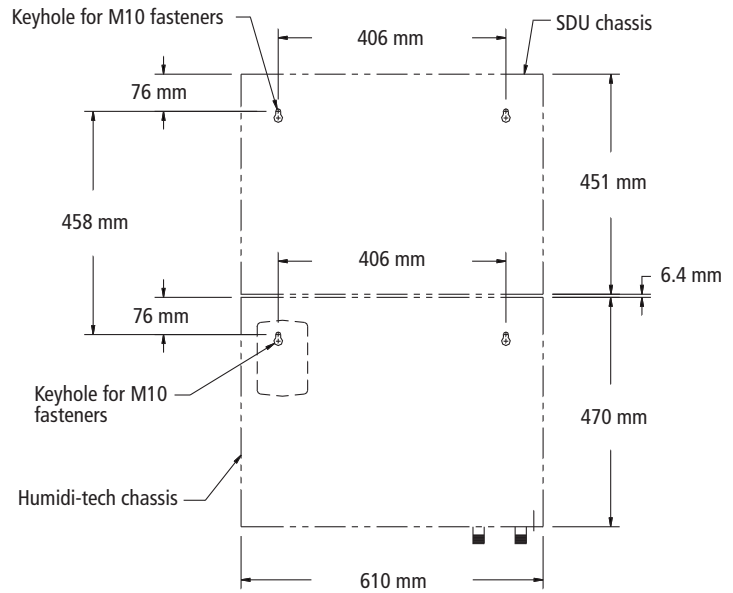
OM-56-1

Directly above humidifier



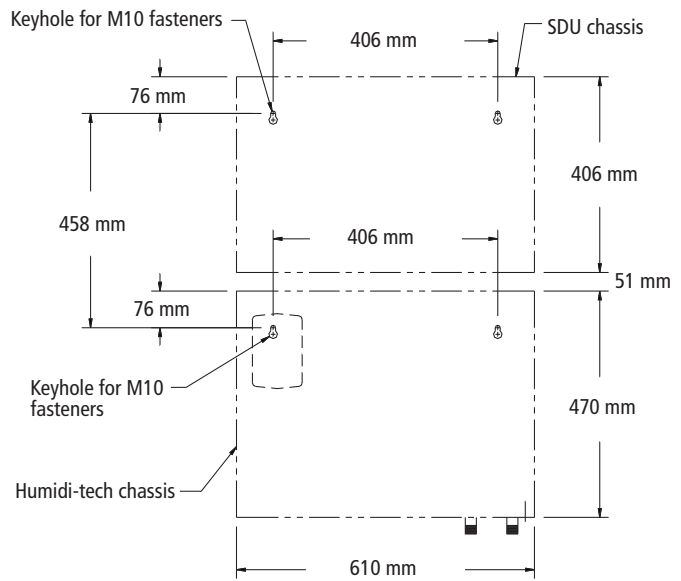
OM-55-1

**Figure 20-1:
Wall-mounted Humidi-tech and SDU-I**



OM-282-4

**Figure 20-2:
Wall-mounted Humidi-tech and SDU-E**



OM-282-7

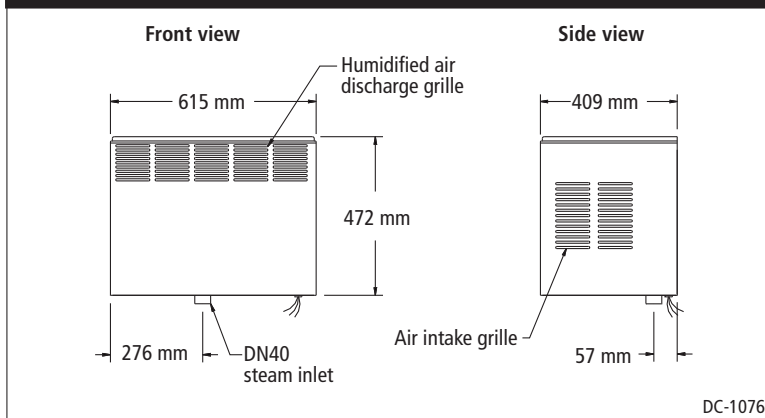
Dispersion: SDU-I and SDU-E

**Table 21-1:
SDU specifications**

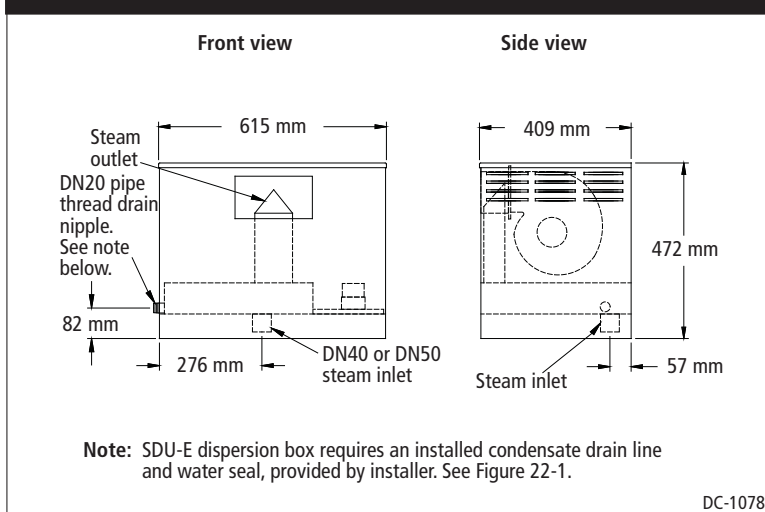
SDU model	Maximum capacity	Shipping weight	Amps at 120V (50/60 Hz)	Horsepower	m ³ /s	dB*
SDU-I	13.6 kg/h	31 kg	3.20	1/5	0.36	58
SDU-E	46.3 kg/h	28 kg	2.07	1/8	0.26	64

* Measurement taken 2 m in front of SDU cabinet.

**Figure 21-2:
SDU-I mechanical detail**



**Figure 21-3:
SDU-E mechanical detail**



Dispersion: SDU-I and SDU-E

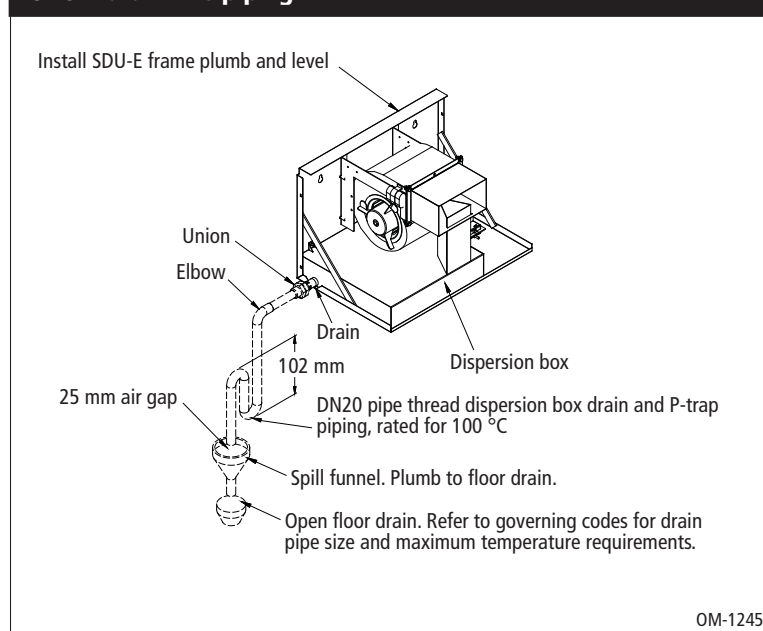
SDU-E condensate drain connection

1. Piping must be minimum DN20 and rated for 100 °C minimum continuous operating temperature.
2. Drain line must be piped as shown in Figure 22-1. Provide a 152 mm drop prior to a 102 mm water seal to ensure condensate drainage from the SDU-E, and to keep steam from blowing out of the drain line.
3. After the water seal, run the drain line to an open drain with a 25 mm vertical air gap. Cut the drain line at a 45 degree angle on the end above the drain to permit a direct stream of water into the drain pipe while maintaining a 25 mm air gap.
4. All drain lines must be installed and sized according to governing codes.
5. The drain line should have a union installed directly on the dispersion box DN20 nipple to accommodate future removal of the SDU-E shroud.
6. A drain line and water seal must be connected to the SDU-E fan unit dispersion box DN20 nipple. **If the condensate is not drained from the dispersion box, standing water will accumulate. See Warning below.**
7. The dispersion box is constructed with a pitch toward the drain; however, the SDU-E frame must be installed plumb and level for the dispersion box to drain properly.

Mounting SDU-E

- SDU-E requires an installed condensate drain line and water seal (provided by installer). See Figure 22-1 and instructions at left.
- Spread dimensions greater than 3' (1 m) may require additional clearance. See Figure 23-1 and Table 23-1).

**Figure 22-1:
SDU-E drain line piping**



! WARNING

Hazards of standing water in SDU-E

If standing water is allowed to accumulate in the dispersion box, it can:

- Cause bacteria and mold growth, which can cause illness.
- Affect SDU-E fan unit performance.
- Cause 212 °F (100 °C) water to discharge from the SDU-E fan unit, which can cause severe personal injury.

Dispersion: SDU-I and SDU-E

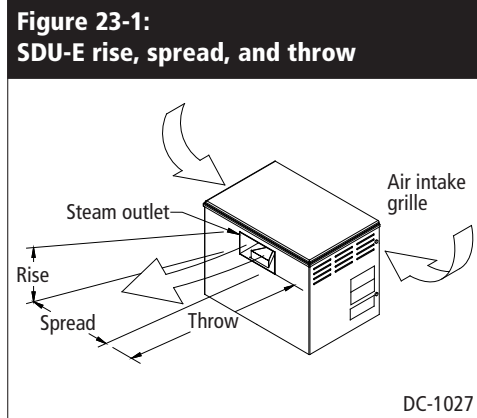
SDU-E rise, spread, and throw

As steam is discharged from the SDU-E, it quickly cools and turns to a visible fog that is lighter than air. As this fog is carried away from the SDU-E by the airstream, it tends to rise toward the ceiling. If this fog contacts solid surfaces (columns, beams, ceiling, pipes, etc.) before it disappears, it could collect and drip as water. The greater the space relative humidity, the more the fog will rise, throw and spread.

Table 23-1 lists the minimum rise, throw and spread non-wetting distances for SDU-E at 40%, 50% and 60% RH in the space. Surfaces cooler than ambient temperature, or objects located within this minimum dimension, can cause condensation and dripping. To avoid steam impingement on surrounding areas, observe the minimum non-wetting distances in Table 23-1.

The SDU-E contains a blower (120 V, single-phase, 60 Hz) and an airflow proving switch (field-wired to the humidifier electrical panel). A wiring diagram of the SDU-E is included with the unit.

On a call for humidity, the humidifier begins producing steam, and the start relay energizes the SDU-E blower. When the call for humidity is satisfied, the Vapor-logic4 controller keeps the blower running to disperse residual moisture using a time delay.



**Table 23-1:
SDU-E minimum nonwetting distances**

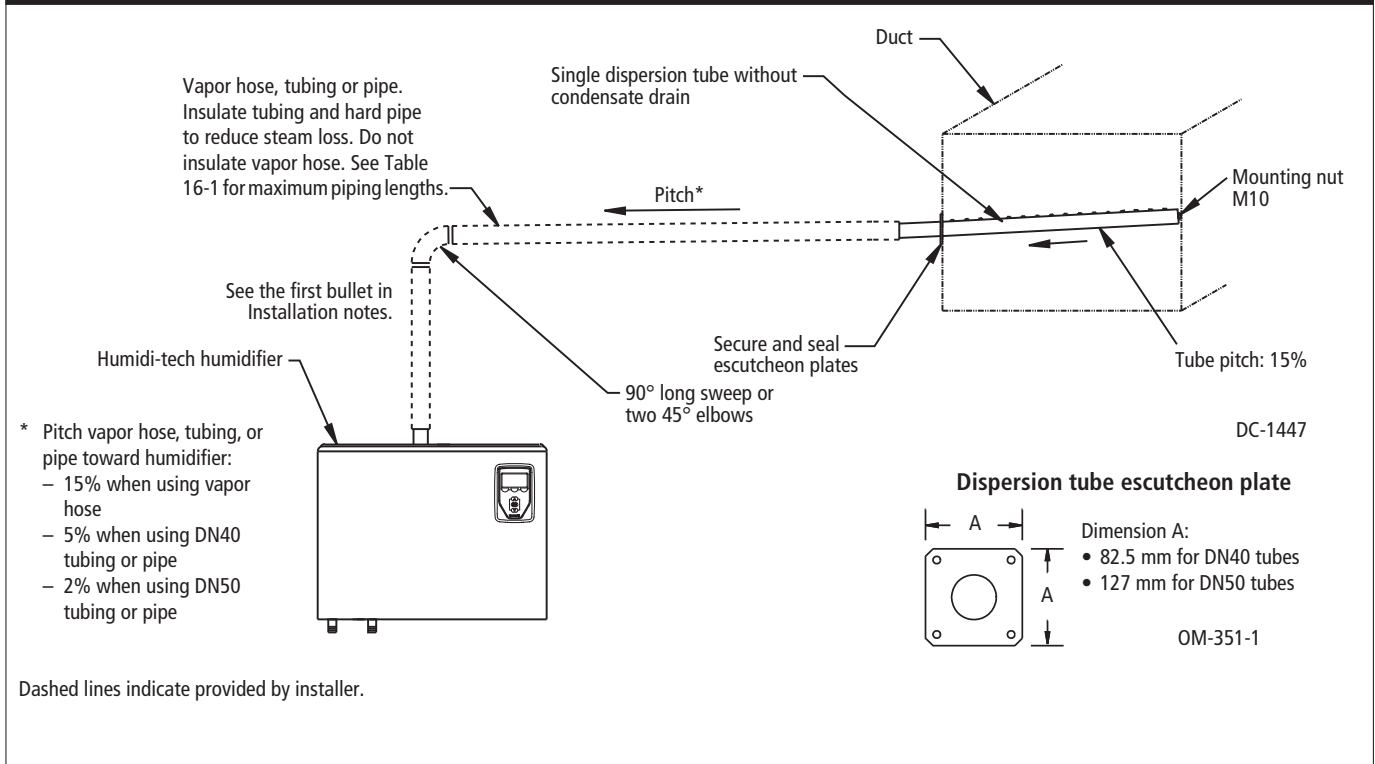
kW	Maximum steam capacity (kg/h)	40% RH @ 21 °C			50% RH @ 21 °C			60% RH @ 21 °C		
		Rise (m)	Spread (m)	Throw (m)	Rise (m)	Spread (m)	Throw (m)	Rise (m)	Spread (m)	Throw (m)
2	2.7	0.3	0.3	1.5	0.5	0.5	2.0	0.8	0.8	2.3
4	5.4	0.3	0.3	1.5	0.5	0.5	2.0	0.8	0.8	2.3
6	8.2	0.3	0.3	1.5	0.5	0.5	2.0	0.8	0.8	2.3
8	10.9	0.3	0.3	1.7	0.5	0.5	2.0	0.8	0.8	2.3
10	13.6	0.5	0.5	1.8	0.6	0.6	2.1	1.0	1.0	2.5
12	16.3	0.5	0.5	1.8	0.6	0.6	2.1	1.0	1.0	2.5
14	19.1	0.6	0.6	2.1	0.6	0.6	2.1	1.0	1.0	2.7
16	21.8	0.6	0.6	2.1	0.6	0.6	2.1	1.0	1.0	2.7
21	28.6	0.6	0.6	2.3	0.8	0.8	3.0	1.0	1.0	3.7
25	34.0	0.6	0.6	2.5	0.8	0.8	3.2	1.1	1.1	3.8
30	40.9	0.6	0.6	2.5	0.8	0.8	3.2	1.1	1.1	3.8
34	46.3	0.6	0.6	2.5	0.8	0.8	3.2	1.1	1.1	3.8

Notes:

- Surfaces or objects directly in the path of vapor discharge may cause condensation and dripping.
- To avoid steam impingement on surrounding areas, observe the minimum nonwetting dimensions in this table.
- Rise: The minimum nonwetting height above the steam outlet of the SDU-E.
- Spread: The minimum nonwetting width from the steam outlet of the SDU-E.
- Throw: The minimum nonwetting horizontal distance from the steam outlet of the SDU-E.

Dispersion: Single tube

**Figure 24-1:
Single tube without condensate drain**



WARNING

Hot surface and steam hazard
 Dispersion tube, steam hose, tubing, or hard pipe can contain steam, and surfaces can be hot. Discharged steam is not visible. Contact with hot surfaces or air into which steam has been discharged can cause severe personal injury.

Important:

Failure to follow the recommendations in this section can result in excessive back pressure on the humidifier. This will result in unacceptable humidification system performance such as leaking gaskets, blown water seals, erratic water level control, and spitting condensate from the dispersion tube.

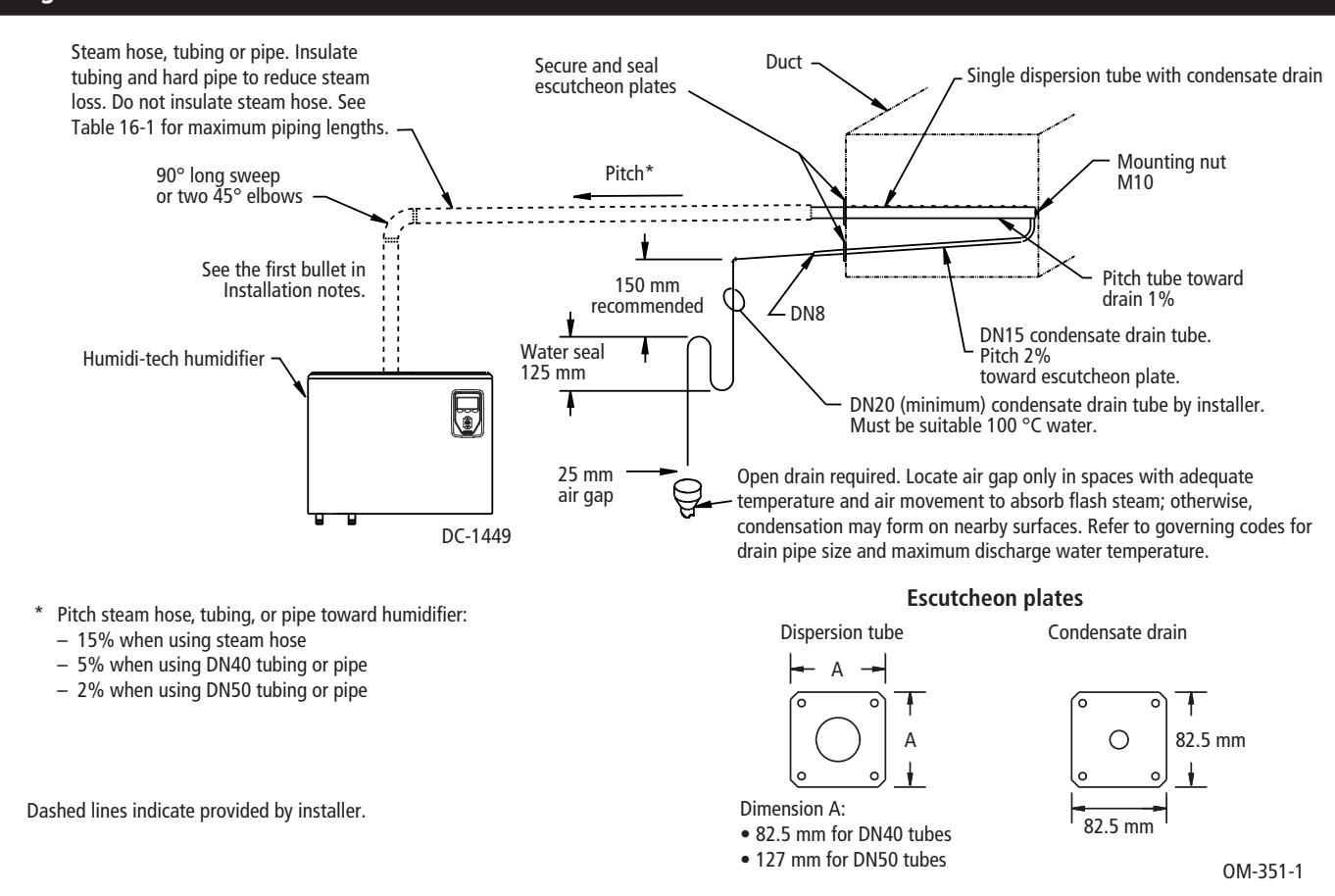
Installation notes

- Use DRI-STEEM’s hard pipe adapter kit to connect the steam outlet to hard pipe. Use a hose clamp to connect the steam outlet to steam hose. Use a hose cuff and clamps to connect the steam outlet to tubing.
- Thin-walled tubing heats up faster than heavy-walled pipe causing less steam loss at start-up.
- Hard pipe or tubing diameter must match Humidi-tech steam outlet size DN40, DN50, or NPT connection.
- See the Maximum Steam Carrying Capacity and Steam Loss tables on Page 16.
- Maximum capacity of dispersion tube without condensate drain:
 - DN40: 13 kg/h
 - DN50: 25.8 kg/h
- Maximum capacity of dispersion tube with condensate drain:
 - DN40: 25.8 kg/h
 - DN50: 38.6 kg/h

Continued

Dispersion: Single tube

**Figure 25-1:
Single tube with condensate drain**



Installation notes (continued)

- Orient dispersion tube with tubelets (steam orifices) pointing up.
- If mounting the humidifier above the level of dispersion tube, see “Drip tee installation” on Page 18.
- Table 25-1 lists hose kit sizes by humidifier model. Note that the capacities of models 30 and 34 require multiple tube assemblies and cannot use a hose kit. For multiple tube assemblies, see “Rapid-sorb,” beginning on Page 26.

**Table 25-1:
Hose kit sizing by model**

HT model	Hose kit (vapor hose, dispersion tube, and hardware)	Maximum capacity of dispersion tube (kg/h)
2 – 8	DN40 hose kit without drain	13
10 – 16	DN40 hose kit with drain	25.8
	DN50 hose kit without drain	25.8
21 – 25	DN50 hose kit without drain	38.6
30 – 34	These models require multiple tube assemblies and cannot use a hose kit.	

Dispersion: Rapid-sorb

WARNING

Hot surface and steam hazard

Dispersion tube, steam hose, tubing, or hard pipe can contain steam, and surfaces can be hot. Discharged steam is not visible. Contact with hot surfaces or air into which steam has been discharged can cause severe personal injury.

Read all dispersion instructions in this manual, and follow the installation instructions below:

- Unpack shipment and verify receipt of all Rapid-sorb components with packing list. Report any shortages to DRI-STEEM immediately. The components typically include the following:
 - Multiple dispersion tubes
 - Header
 - 19 mm × 51 mm L-bracket

Note: Dispersion tubes, header, and L-bracket are each tagged with the customer requested identification number.

 - A single duct escutcheon plate the size of the header
 - Slip couplings or hose cuffs and clamps
 - Accessories such as duct plates, slip couplings, or hose cuffs
 - Bolts and washers for mounting the dispersion tubes to the bracket
- L-bracket mounting holes (see note at left):
 - L-bracket 1270 mm long or shorter has a mounting hole 100 mm from each end for mounting the L-bracket to the duct or air handler wall.
 - L-bracket longer than 1270 mm has an additional mounting hole in the center.

Note: Hardware for mounting the L-bracket to the duct or air handler wall and the hardware for the header support bracket is not provided.
- Select an installation location that provides necessary access in and around the ductwork or air handler.
- The Rapid-sorb typically is installed centered side to side in a duct, or is installed across the face of a coil in an air handler.
- The center line of the outer dispersion tubes should never be closer than 114 mm from the side of the ductwork or air handler wall.
- The following instructions are for a typical Rapid-sorb installation — horizontal-airflow duct with Rapid-sorb header either inside or outside the duct. See the Dri-calc Installation Guides library or contact your representative/distributor or DRI-STEEM for installation instructions for air handler or vertical airflow applications.

Important: Before marking and drilling holes in the duct or air handler, refer to ALL pitch requirements for the Rapid-sorb assembly you received (see Table 27-1). The size, quantity, and location of penetrations are determined by the dimensions and configuration of the Rapid-sorb assembly you received.

Important:

Failure to follow the recommendations in this section can result in excessive back pressure on the humidifier. This will result in unacceptable humidification system performance such as leaking gaskets, blown water seals, erratic water level control, and spitting condensate from the dispersion tube.

Dispersion: Rapid-sorb

Pitch requirements

- For Rapid-sorb with the header outside a horizontal-airflow duct, consider the following:
 - DN40 dispersion tubes: Use a fastener of sufficient length to accommodate the 1% pitch requirements toward the DN20 header drain fitting.
 - DN50 dispersion tubes: The bracket can be mounted flush to the ductwork. The 1% pitch typically can be accomplished in the length of the hose cuffs used to connect the tubes to the header.
- See Table 27-1 and the drawings on the following pages for pitch requirements.

**Table 27-2:
Rapid-sorb dispersion tube capacities**

Tube capacity	Tube diameter
kg/h	DN
≤ 16	40
17-32	50

**Table 27-3:
Rapid-sorb header capacities**

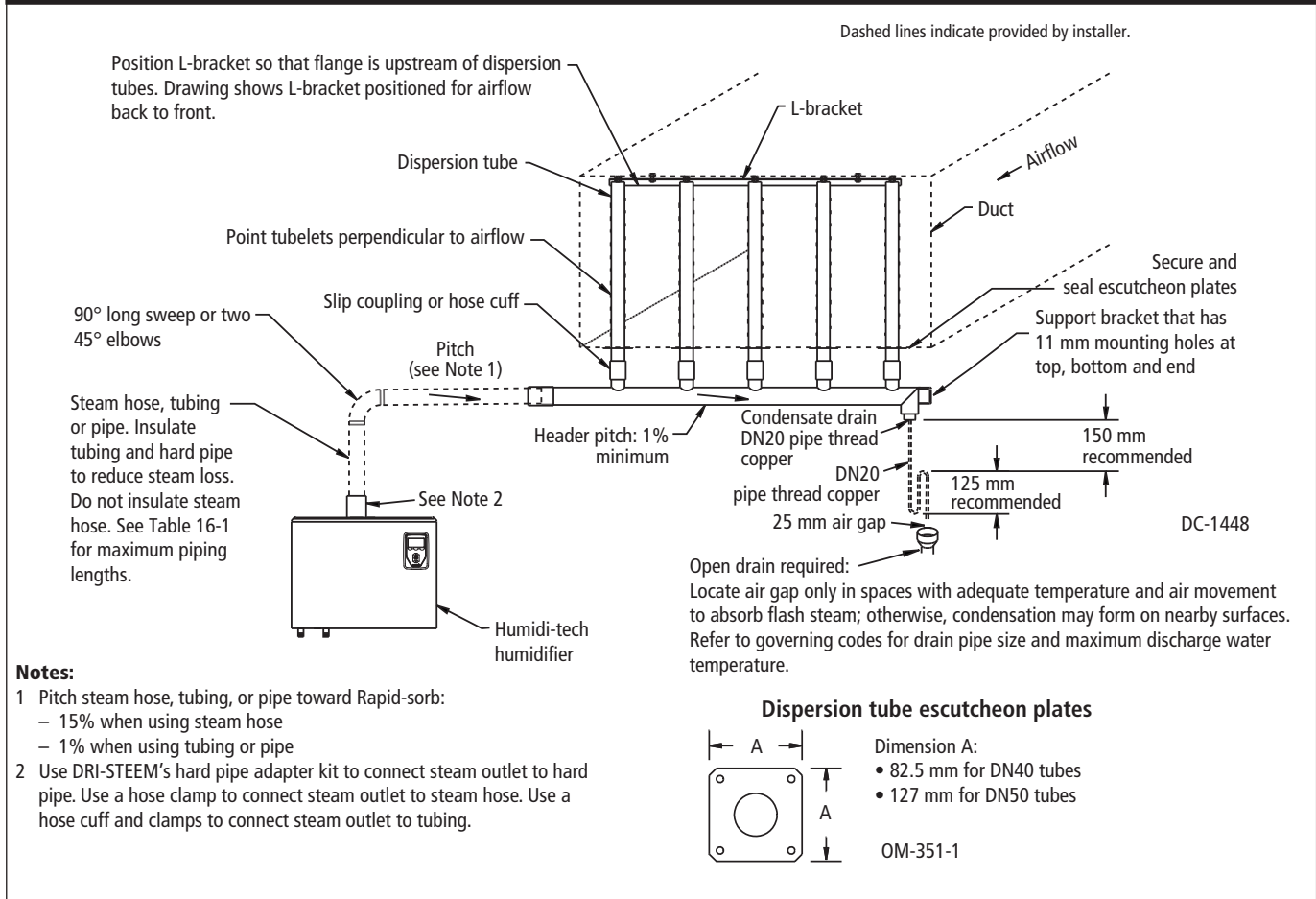
Header capacity	Header diameter
kg/h	DN
≤ 113	50
114-227	80
228-363	100
364-591	125
592-955	150

**Table 27-1:
Pitch of interconnecting piping, dispersion tubes, and headers for Rapid-sorb evaporative dispersion units**

Airflow	Type of interconnecting piping	Diameter of interconnecting piping	Pitch of interconnecting piping	Pitch of dispersion tubes	Pitch of header
Horizontal	Vapor hose	DN40 DN50	15% toward Rapid-sorb	Vertically plumb	1% toward condensate drain
	Tubing or pipe	DN40 DN50	1% toward Rapid-sorb		
Vertical	Vapor hose	DN40 DN50	15% toward Rapid-sorb	15% toward header	1% toward condensate drain
	Tubing or pipe	DN40 DN50	1% toward Rapid-sorb		

Dispersion: Rapid-sorb

Figure 28-1:
Rapid-sorb in a horizontal airflow with header outside the duct



Header outside of duct, horizontal airflow

1. Mark and cut holes in the ductwork for the dispersion tubes. Use the L-bracket as a template to mark the holes on the duct floor.
2. Temporarily, loosely suspend or support the header below the final location. Vertical balance point of the dispersion tube length dictates where the header should be suspended or temporarily supported.
3. Mount the dispersion tubes to the header with the slip coupling or hose cuff (provided).
 - When installing slip couplings for DN40 dispersion tubes, take care not to shear the O-rings.
 - Set the slip coupling on the header stub or dispersion tube so the O-ring is resting on the face of the tubing.
 - Rotate the slip coupling as you push it onto the tubing.
 - The O-rings are lubricated at the factory. If additional lubrication is necessary, DO NOT use a petroleum-based lubricant.

Dispersion: Rapid-sorb

4. Position the flange of the L-bracket so it is upstream of the tubes when the assembly is raised and fastened into position. Fasten the L-bracket to the end of the dispersion tubes with the provided bolt, lock washer, and flat washer.
5. Before tightening the L-bracket bolts to the dispersion tubes:
 - For DN40 dispersion tubes:
 - Dispersion tube will rotate in slip coupling. Verify that dispersion tube orifices are directed perpendicular to airflow.
 - Dispersion tube and slip coupling must be fully engaged on header stub for O-rings to provide a seal.
 - For DN50 dispersion tubes:

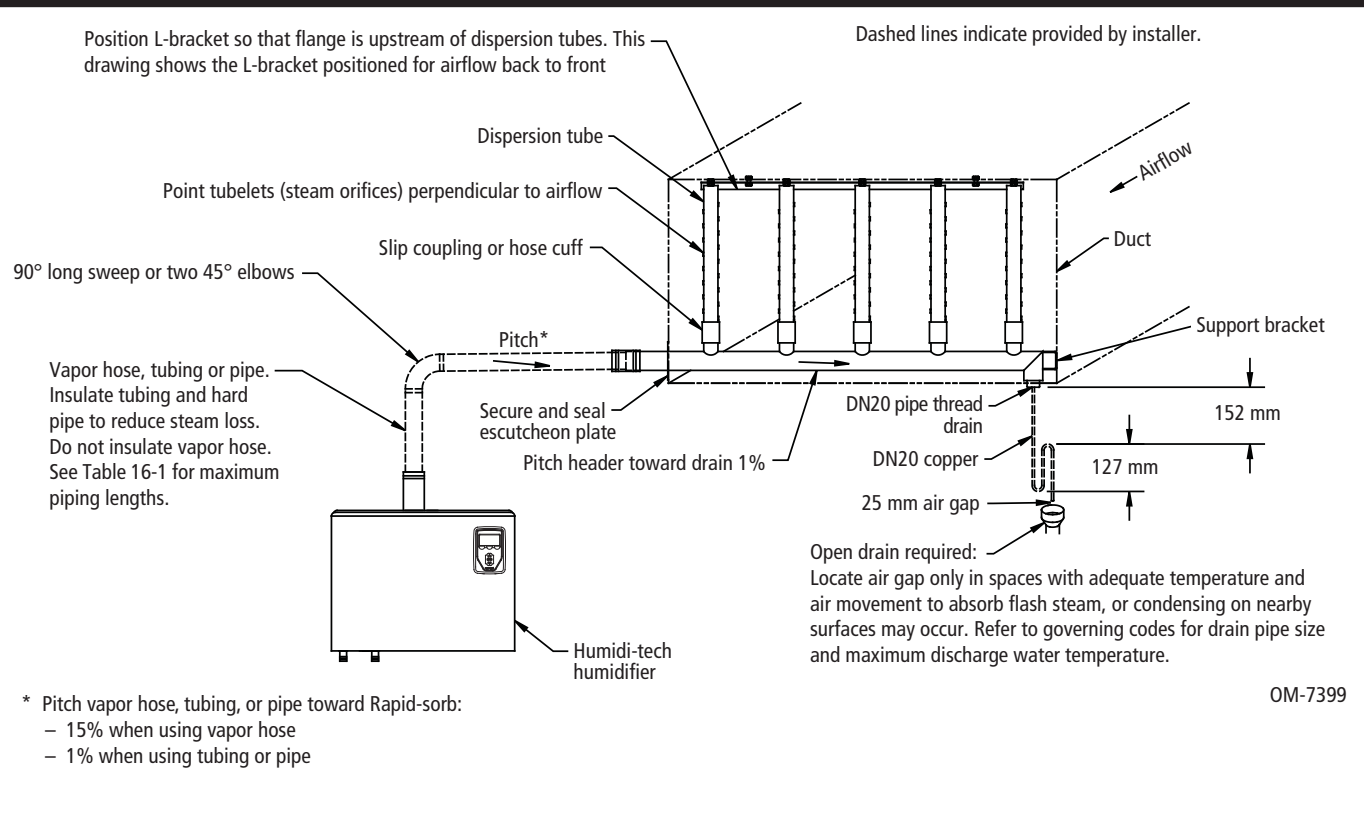
Before securing hose cuff in place with hose clamps on dispersion tube and the header stub, verify that dispersion tube orifices are directed perpendicular to airflow.
6. Slide the assembly up until the L-bracket aligns with the mounting holes in the duct.
 - For DN40 dispersion tubes:
 - Header pitch is duplicated in the L-bracket.
 - Dispersion tube and slip coupling must be fully engaged on header stub for O-rings to provide a seal.
 - High end of L-bracket can be fastened tight to duct or air handler.
 - Fastener on low end of L-bracket must be long enough to compensate for pitch. Use a nut on both sides of L-bracket and duct or air handler for stability.
 - For DN50 dispersion tubes:
 - Fasten bracket to top of duct and use hose cuffs to compensate for header pitch.
 - Before securing hose cuffs with hose clamps on dispersion tube and header stub, verify that header pitch, 1% toward drain, is maintained.
7. Permanently secure both ends of header, and verify that header pitch, 1% toward drain, is maintained.
8. Verify that all fasteners are secure:
 - L-bracket to duct
 - Dispersion tubes to L-bracket
 - Hose clamps on DN50 tubes
9. Secure and seal the dispersion tube escutcheon plate and condensate drain tube escutcheon plate around the respective tubes, if applicable.

Note:

See Page 32 for steam supply and condensate drain line connection instructions.

Dispersion: Rapid-sorb

**Figure 30-1:
Rapid-sorb in a horizontal airflow with header inside the duct**



⚠ WARNING

Hot surface and steam hazard

Dispersion tube, steam hose, tubing, or hard pipe can contain steam, and surfaces can be hot. Discharged steam is not visible. Contact with hot surfaces or air into which steam has been discharged can cause severe personal injury.

Header inside of duct, horizontal airflow

1. Mark and cut holes in ductwork or air handler for steam header penetration, condensate drain piping, and header support bracket fastener. Allow 1% header pitch toward the support bracket when you drill the hole for the header support bracket fastener.
2. Loosely fasten the header in place.
3. Rotate the header 90° so the header stubs point horizontally in the duct.

When installing in an air handler, the rotation of the header is often less than 90°. Typically, due to the condensate drain piping requirements, the header can be set on the floor of the air handler, assembled in the vertical position, and then raised and mounted in place.

Dispersion: Rapid-sorb

4. Mount the dispersion tubes on the header with the slip couplings or hose cuffs:
 - When installing slip couplings for DN40 dispersion tubes, take care not to shear O-rings.
 - Set slip coupling on header stub or dispersion tube so O-ring is resting on face of tubing.
 - Rotate slip coupling while pushing it onto the tubing.
 - O-rings are lubricated at factory. If additional lubrication is necessary, DO NOT use petroleum-based lubricant.
5. Allow the dispersion tubes to rest against the bottom of the duct.
6. Position the flange of the L-bracket so it is upstream of the tubes when the assembly is rotated into position. Fasten the L-bracket to the end of the dispersion tubes with the provided bolt, lock washer, and flat washer.
7. Rotate the assembly up until the L-bracket aligns with the mounting holes in the duct or air handler.
 - DN40 dispersion tubes:
 - Header pitch is duplicated in the L-bracket.
 - Dispersion tube and slip coupling must be fully engaged on header stub for O-rings to provide a seal.
 - High end of L-bracket can be fastened tight to duct or air handler.
 - Fastener on low end of L-bracket must be long enough to compensate for pitch. Use a nut on both sides of L-bracket and duct or air handler for stability.
 - DN50 dispersion tubes
 - Fasten bracket to top of duct and use hose cuffs to compensate for header pitch.
 - Before securing hose cuffs with hose clamps on dispersion tube and header stub, verify that dispersion tube orifices are directed perpendicular to airflow.
8. Verify that all fasteners are secure:
 - L-bracket to duct
 - Dispersion tubes to L-bracket
 - Hose clamps on DN50 tubes
 - Header support bracket fastener
9. Secure and seal the header escutcheon plate around the header.

Note:

See Page 32 for steam supply and condensate drain line connection instructions.

Dispersion: Rapid-sorb

CAUTION

Operate Rapid-sorb within rated steam capacity

Excessive steam flow to the Rapid-sorb steam dispersion assembly can cause condensate to exit the tubelets, which can cause water damage and standing water in the duct or air handler.

To avoid condensate exiting the tubelets, do not operate the Rapid-sorb beyond its rated capacity.

Steam supply connections to Rapid-sorb header

Connect the steam supply interconnecting piping from the humidifier to the Rapid-sorb. The steam supply piping requires a minimum of 1% pitch toward the header.

If multiple humidifiers are supplying one Rapid-sorb, a multiple steam supply connector is provided. Typically, the multiple steam supply connector attaches to the Rapid-sorb header supply end with hose cuff and clamps:

1. Route the necessary number of steam supplies from the humidifiers to the steam supply connector.
2. Position the steam supply connector to accept the steam supplies while maintaining the necessary pitch.
3. Make sure the hose clamps on the steam supply connector and header are tight.

Condensate drain connections to Rapid-sorb header

Piping must be minimum DN20 and rated for 100 °C minimum continuous operating temperature.

The condensate drain line must be piped as shown in Figures 28-1 and 30-1. Provide a 152 mm drop prior to a 127 mm water seal to:

- Ensure drainage of condensate from the header
- Keep steam from blowing out of the drain line

After the water seal, run the drain line to an open drain with a 25 mm vertical air gap.

- Cut the drain line at a 45° angle on the end above the drain to permit a direct stream of water into the drain pipe while maintaining a 25 mm air gap.
- Locate air gap only in spaces with adequate temperature and air movement to absorb flash steam, or condensing on nearby surfaces may occur.

All drain lines must be installed and sized according to governing codes.

Ultra-sorb

For Ultra-sorb steam dispersion panel instructions, see the installation, operation, and maintenance manual shipped with the Ultra-sorb.

Start-up procedure

After the system is installed and connected properly:

1. Verify that the humidifier, controls, piping, electrical connections, steam supply, and dispersion units(s) are installed according to the following:
 - Installation instructions in this manual
 - *Vapor-logic4 Installation and Operation Manual*
 - Installation section
 - Installation checklist
 - Ladder style wiring diagram (inside humidifier electrical panel cover)
 - External connections wiring diagram (inside humidifier electrical panel cover)
 - All governing codes
2. Verify that all electrical connections are secure before applying power. See torque requirements in Table 38-1.
3. Make sure all electrical covers are in place and secure. See Warning at right.
4. Verify that the humidifier is mounted level and securely supported before filling with water. See operating weights in Table 4-1.
5. Verify that the humidifier is level front to back and side to side after it is full of water.
6. Read the “Operation” section of the *Vapor-logic4 Installation and Operation Manual*.

Note: During start-up, do not leave the humidifier unattended.
7. Perform all applicable “Start-up checklist” items. See Page 34.
8. Monitor humidifier operation through multiple fill cycles. The humidifier operating status appears on the keypad/display.
9. On tap/softened water units, water skims from the humidifier after every fill cycle. Adjust the amount of skim by increasing or decreasing the skim time (see the *Vapor-logic4 Installation and Operation Manual*).

At start-up, DRI-STEEM recommends initially running the humidifier with the factory default setting for skim time. See “Maintenance,” beginning on Page 35.

The *Vapor-logic4 Installation and Operation Manual* is a comprehensive operation manual. Refer to it for information regarding the following features:

- Keypad/display setup and menu information
- Control input signals and functions
- Drain, flush, and skim features
- Safety features
- Alarm screens and fault messages

The manual was shipped with your humidifier and is available at our Web site: www.drsteem.com

WARNING

Electric shock hazard

Only qualified electrical personnel should perform start-up procedure.

Contact with energized circuits can cause property damage, severe personal injury or death as a result of electrical shock or fire.

Make sure that all electrical covers are in place and secure before turning on electrical power. These include the heater terminal cover, electrical panel cover, and subpanel access panels.

CAUTION

Damage from dry startup

In the event the humidifier tank does not contain water and the heaters are energized, turn main power off. Operation of the heaters without water will cause damage to the humidifier. Before turning main power on, verify that all wiring has been completed per the wiring instructions in this manual and the unit wiring diagrams.

Start-up checklist

If an item in the Start-up checklist below does not apply to your system, skip to the next item and continue the process.

- Read this manual and all other information that was provided with your humidifier.
- Verify that all field wiring is done according to the instructions in this manual and in the humidifier wiring diagram.
- Confirm that the input signal is consistent with the Vapor-logic4 controller's expected input signal. Input signals are listed in the Vapor-logic4 Setup menu. See "Installation Step 2: Setup" in the *Vapor-logic4 Installation and Operation Manual*.
- Confirm that proper grounding and an approved earth ground are provided.
- Turn on the water supply, and confirm that the drain valve is closed.
- Turn on power to the humidifier, and confirm the Main menu is displayed on the keypad/display. The display may take several seconds to appear as the controller powers up.
- Confirm in the Main Menu that the mode is "Auto" and that tank status is "Filling."
- When "Filling" appears in main menu, confirm that the tank is filling with water.
- In the Status screen, confirm that the Duct Airflow Switch is closed.
- In the Status screen, confirm that the high limit humidistat input is closed or the high limit transmitter is connected.
- Make sure the tank has filled with water. See the "Damage from dry startup" Caution on Page 33.
- With sufficient water in the tank, the airflow switch closed, the high limit closed, and the humidifier getting a call for humidity, verify that the heater outputs are activated.
- Check the amp draw of the heaters. Refer to the humidifier wiring diagram for the proper rating.
- If you experience difficulties, have the keypad/display information available along with the serial number and humidifier Model, and call DRI-STEEM Technical Support at 800-328-4447.

Tap/softened water

The best way to determine how often your humidifier needs maintenance is to remove the tank cover and inspect it for mineral deposits after three months of duty. Hours of operation and duty cycle will determine your maintenance schedule, as will water quality.

Water quality and maintenance

Maintenance requirements vary with water quality, because tap and softened water carry a variety of minerals and other materials in a mix that varies from location to location. Very hard (high mineral content) water requires more frequent cleaning and drain/flush cycles than water with low mineral content.

Softened water significantly reduces mineral accumulation inside the humidifier.

Note: Solids, like silica, are not removed in the softening process.

Skim duration

Skim duration determines the quantity of water skimmed with each fill cycle and is field adjustable using the Vapor-logic4 keypad/display.

Skimming reduces the need for frequent humidifier cleaning. Each time the tank refills, it fills to a level just above the lip of the skim/overflow fitting. A portion of the fill water flows out of the skim/overflow fitting to the drain, which flushes minerals left by the previous evaporating cycle and skims away surface residue.

Both humidifier cleaning and heated water flowing to the drain are operational costs. DRI-STEEM recommends that the user observe and adjust the skim duration to achieve a balance between reducing mineral buildup and conserving heated water.

WARNING

Electric shock hazard

Contact with energized circuits can cause severe personal injury or death as a result of electric shock. To prevent shock, disconnect electrical power before performing service or maintenance procedures on an part of the humidification system.

When performing maintenance on the humidifier:

- Always switch the keypad control mode to Standby.
- Place all power disconnects in OFF position and lock in OFF position.
- Close the field-installed manual supply water shut-off valve.

WARNING

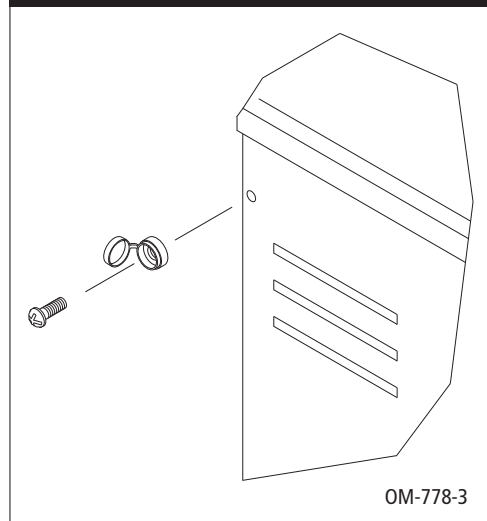
Hot surface and hot water hazard

Do not touch the tank or drain piping until the unit has had sufficient time to cool, or serious injury can occur.

Opening the drain valve when the tank is hot can discharge water with a temperature up to 212 °F (100 °C) into the plumbing system. This can cause damage to the plumbing system if the humidifier is not properly connected to a water tempering device such as a DRI-STEEM Drane-kooler™.

Tap/softened water

Figure 36-1:
Cover enclosure screw cap detail



Humidifier De-scaling Solution

Scale buildup on humidifier heaters acts as an insulator, reducing humidifier performance while increasing energy costs. To keep humidifiers operating as efficiently as possible, remove scale with DRI-STEEM's Humidifier De-scaling Solution, available for purchase from your DRI-STEEM representative or distributor.

The De-scaling Solution cleans without risk of corroding humidifier tanks or welds. The De-scaling Solution also cleans surfaces unreachable by hand scraping.

DRI-STEEM's Humidifier De-scaling Solution is the only approved cleaner/de-scaler for use with DRI-STEEM humidifiers. Use of other cleaners/de-scalers may void your DRI-STEEM warranty.

Cool down humidifier

Before performing any maintenance, allow the tank to cool down. Fresh make-up water is used to speed up cooling. Do not close the manual water supply before cooling down the humidifier; otherwise the tank could stay hot for several hours.

- Insulated and uninsulated tanks will have hot surfaces.
- Verify that there is no call for humidity and that the aquastat set point (adjusted using the keypad/display Setup screens) is less than room temperature (default setting is 40 °F [4 °C]) so that the heaters do not energize while cooling down the tank.
- Models with a standard drain valve:
 - Manually open the drain valve by moving the valve lever located on the back of the drain valve to the manual open position. The fill valve eventually opens.
 - Let the fill water run until the tank is cooled, then shut off the field-installed manual supply water shut-off valve.
 - Let the tank drain, then manually close the drain valve.
- Models with optional drain valves:
 - For drain valves without the manual open lever, use the keypad to perform the cool down process.
 - Go to the control modes screen and select Manual Drain.
 - Allow approximately half the water to drain out of the tank.
 - In the Control Modes screen select Auto; the fill valve opens and the humidifier cools down.
 - When the fill valve closes, select Manual Drain in the Control Modes screen and let the tank drain dry. The humidifier should be cool enough to work on.
 - For more information about using the keypad, see the *Vapor-logic4 Installation and Operation Manual*.

Inspection and maintenance

1. **Annually** (also recommended when maintenance is performed)
 - Inspect tank and gaskets for leaks.
 - Measure current draw of heaters and verify amp values per stage by comparing to the wiring diagram located inside the subpanel cover. This identifies any burned out heaters. Only qualified electrical personnel should perform this task.
 - All safety devices in the control circuit should be cycled on and off to verify they are functioning. These include:
 - High limit switch
 - Airflow proving switch
 - Low water level probe. Pull out probe plug; fill valve should energize.

Tap/softened water

2. Seasonally (or as required, depending on water quality)

- Remove the evaporating chamber:
 - Remove the two fasteners on each side of the cover enclosure (see Figure 36-1).
 - Remove the enclosure. See “Electric shock hazard” Warning at right.

Note: If the humidifier has an SDU mounted directly above it, remove the SDU cover before removing the humidifier cover.
 - If the tank is hot, cool it down first. See “Cool down humidifier” on Page 36.
 - Shut off the water supply.
 - Allow the tank to drain completely.
 - Shut off the electrical supply.
 - Disconnect the fill line at the supply side of the fill valve.
 - Disconnect the electrical plugs between the tank components and the back of the electrical panel (includes: power plug, fill plug, drain plug, water level control plug, tank temperature sensor plug, and thermal trip plug).
 - **Important:** Disconnect by pulling on plug housing. Do not disconnect by pulling on cord or wires.
 - Disconnect the drain union on the back left corner of the frame.
 - Disconnect the steam supply hose from the top of the tank.
 - Lift the tank foot above the frame flange, and slide the tank assembly forward to remove.
- Loosen the four cover bolts and remove the cover assembly from the tank.
- Clean the tank interior using a putty knife or similar flat instrument.
- Clean and inspect probe rod assembly:
 - Unplug the probe plug assembly, and leave ground wire connected to tank.
 - Unscrew probe rod assembly using the probe tool (see Figure 37-1), and clean plastic probe housing, ensuring that all passageways for water flow are clear.
 - Clean probe rods using steel wool or similar mild abrasive material.
 - Inspect composite plastic probe housing. If any signs of cracking, roughness, or deterioration, replace assembly.
 - When sliding probe housing into bracket from which it hangs, orient housing so neither water flow slot directly faces tank wall at back end of bracket.

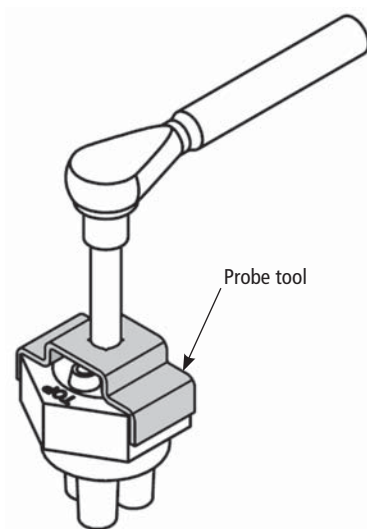
WARNING

Electric shock hazard

Do not remove humidifier electrical panel cover, heater terminal cover, or subpanel access panels until electrical power is disconnected. Improper wiring or contact with energized circuits can cause property damage, severe personal injury, or death as a result of electric shock and/or fire.

Only qualified electrical personnel should perform maintenance procedures.

Figure 37-1:
Probe tool



Remove and install probe assembly with supplied probe tool. Attach a 3/8" square drive to the probe tool.

When installing, torque probe assembly to 13.6 N-m. Probe tools can be ordered from your DRI-STEEM distributor (Part no. 185101).

OM-7395X

Tap/softened water

**Table 38-1:
Humidi-tech torque specifications**

Screw or lug location		Torque
Power block		1.8 N-m
Contactor		1.8 N-m
Heater nut	8.5 mm nut	2.2 N-m
	9.5 mm nut	2.8 N-m
Heater wire lug	10 mm ² wire	4.0 N-m
	6 mm ² wire	2.8 N-m
	<6 mm ² wire	2.2 N-m

- Install the probe and probe plug assembly. Verify ground wire is solidly connected to tank.
- Secure the chamber cover, making sure the cover gasket is seated and the chamber is sealed.
- Re-install evaporating chamber:
 - Reconnect the fill line.
 - Reconnect electrical plugs (the plugs are color coded).
 - Reconnect the drain union.
 - Reconnect the vapor hose.
- Verify electrical connections:
 - Verify that all DIN rail-mounted components are securely fastened to DIN rail.
 - Verify that all power terminal screws and lugs are tight from power block to heaters. See torque specifications in Table 38-1.
 - Verify that all plugs under the humidifier cover are completely plugged in.
- Move the drain valve lever back to the auto position.
- Turn on the water supply.
- Turn on the electrical power.

3. Off-season maintenance

- Perform complete inspection and cleaning of the following:
 - Heaters
 - Probe rods
 - Skimmer port and water seal
 - Humidifier tank
- After cleaning, the humidifier should remain empty until humidification is required.

Tap/softened water

Off-season shut-down procedure

1. Switch off electrical power.
2. Remove the enclosure.
3. Shut off the water supply to the makeup valve.
4. Drain the evaporating chamber, and clean if necessary following the instructions in this manual.
5. Replace the enclosure.
6. Leave the evaporating chamber dry, the power off, and the water shut-off valve closed until the next humidification season.

DI/RO water option

WARNING

Hot surface and hot water hazard

Do not touch the tank or drain piping until the unit has had sufficient time to cool, or serious injury can occur.

Opening the drain valve when the tank is hot can discharge water with a temperature up to 212 °F (100 °C) into the plumbing system. This can cause damage to the plumbing system if the humidifier is not properly connected to a water tempering device such as a DRI-STEEM Drane-kooler™.

WARNING

Electric shock hazard

Do not remove humidifier electrical panel cover, heater terminal cover, or subpanel access panels until electrical power is disconnected. Improper wiring or contact with energized circuits can cause property damage, severe personal injury, or death as a result of electric shock and/or fire.

Only qualified electrical personnel should perform maintenance procedures.

DI/RO humidifiers use DI/RO water. Because these water types are mineral free, cleaning the evaporating chamber should not be necessary. However, there are some maintenance steps that should be followed to ensure all parts of the unit are in working order.

Important: Verify regularly that water processing equipment is operating correctly. The presence of chlorides in improperly processed deionized water will eventually cause pitting and failure of the humidifier tank and its components. Damage caused by chloride corrosion is not covered by your DRI-STEEM warranty.

Cool down humidifier

If the tank is hot, cool it down by opening the manual ball valve on the side of the tank. The float valve will open allowing cool water to run into the tank until it is cool enough to handle. Then shut off the water supply, and allow the tank to drain completely.

Inspection and maintenance

1. Remove the evaporating chamber:

- Remove the two fasteners on each side of the cover enclosure. See Figure 36-1.
- Remove the enclosure. See “Electric shock hazard” Warning at left.

Note: If the humidifier has an SDU mounted directly above it, remove the SDU cover before removing the humidifier cover.

- If the tank is hot, follow the instructions in “Cool down humidifier” above before proceeding.
- Shut off the water supply.
- Allow the tank to drain completely.
- Shut off the electrical supply.
- Disconnect the fill line at the fill fitting.
- Disconnect the electrical plugs between the tank components and the back of the electrical panel (includes: power plug, low water switch plug, tank temperature sensor plug and thermal trip plug).

Important: Disconnect by pulling on plug housing. Do not disconnect by pulling on cord or wires.

- Disconnect the drain union on the back left corner of the frame.
- Disconnect the steam supply hose from the top of the tank.
- Lift the tank foot above the frame flange and slide the tank assembly forward to remove.

DI/RO water option

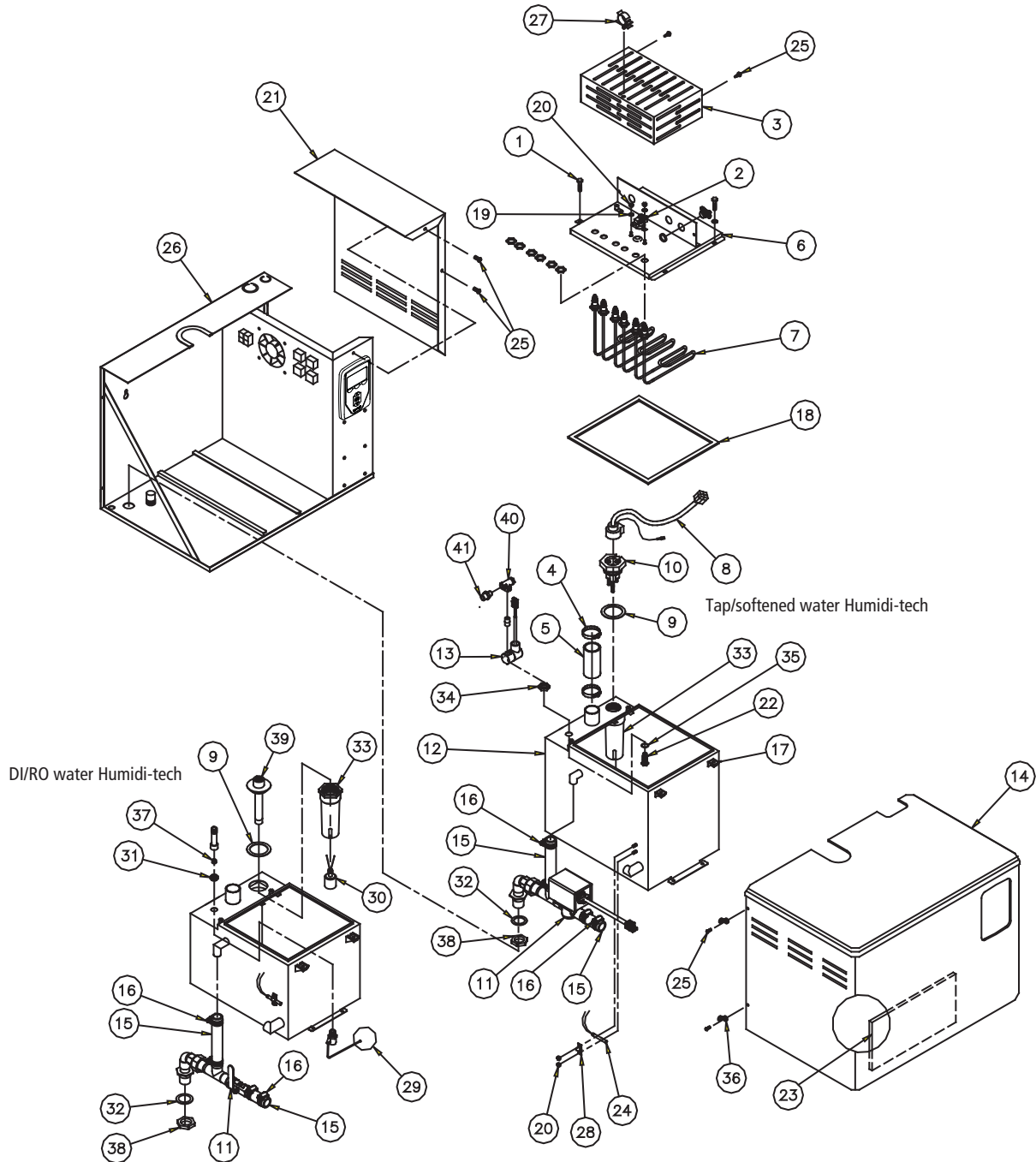
2. Loosen the four cover bolts and remove the cover assembly from the tank.
3. Inspect the tank interior for debris or pitting.
4. Inspect the valve inlet for debris.
5. Check the operation of the float valve and the condition of the float seat.
6. Check the low water switch to make sure the float slides freely on the stem.
7. Secure the chamber cover making sure the cover gasket is seated and the chamber is sealed.
8. Reinstall the evaporating chamber.
 - Reconnect the fill line.
 - Reconnect electrical plugs (the plugs are color coded).
 - Reconnect drain union.
 - Reconnect vapor hose.
9. Verify electrical connections:
 - Verify that all DIN rail-mounted components are securely fastened to DIN rail.
 - Verify that all power terminal screws and lugs are tight from power block to heaters. See torque specifications in Table 38-1.
 - Verify that all plugs under the humidifier cover are completely plugged in.
10. Close the drain valve.
11. Turn on the water supply.
12. Turn on the electrical power.

Off-season shut-down procedure

1. Switch off electric power.
2. Remove the enclosure.
3. Shut off the water supply to the makeup valve.
4. Drain the evaporating chamber by opening the drain valve. For units with an end-of-season drain, refer to the *Vapor-logic4 Installation and Operation Manual*.
5. Replace the enclosure.
6. Leave the evaporating chamber dry, the power off, and the water shut-off valve closed until the next humidification season.

Humidifier

Figure 42-1:
Humidi-tech humidifier replacement parts



OM-768

Humidifier

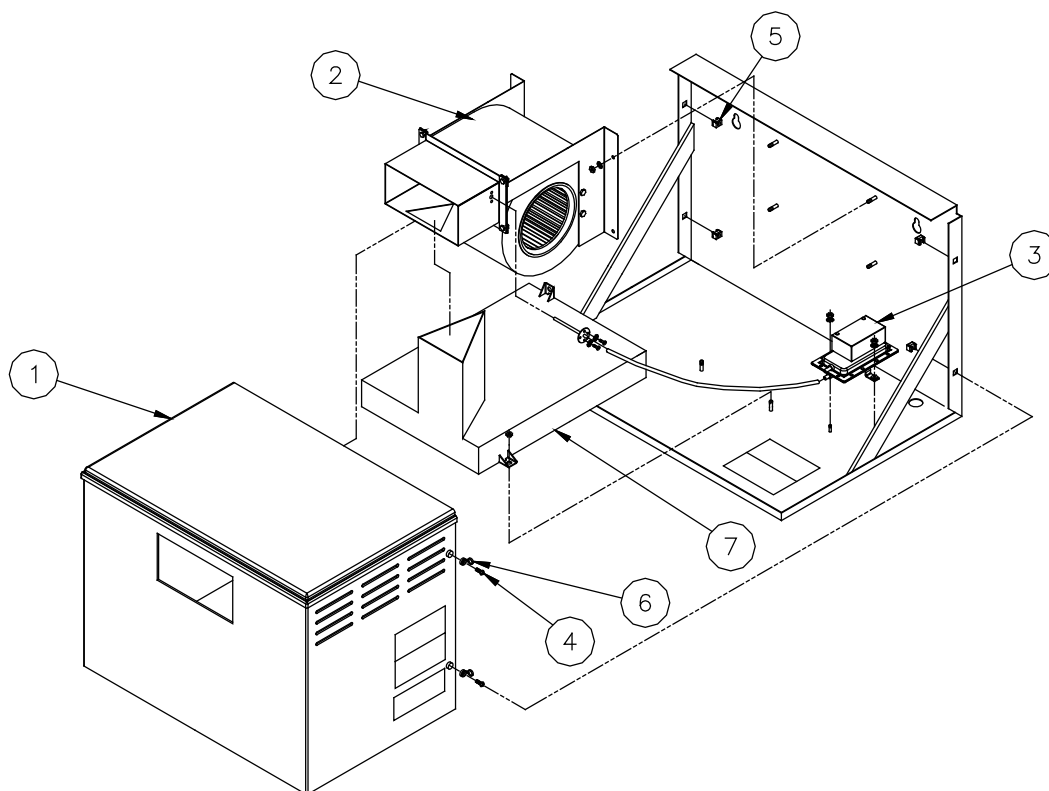
**Table 43-1:
Humidi-tech humidifier replacements parts**

No.	Description	Qty.	Part no.	No.	Description	Qty.	Part no.
1	Head bolt, large Phillips, ¼ - 20 × 1"	4	700300-013	20	Nut, 8-32 hex, pltd	6	700200-002
2	Thermo cut-out	1	409560-001	21	Cover, humidifier electrical panel	1	120277
3	Cover, heater terminal	1	*	22	Fill adapter, HT-2 through HT-4	1	160226-041
4	Hose clamp, 2"	2	700560-200		Fill adapter, HT-6 through HT-16	1	160224-041
5	Hose cuff, 1½"	1	305390- *		Fill adapter, HT-21 through HT-34	1	160224-052
	Hose cuff, 2"	1	305391- *	23	Insulation, panel	1	309845-003
6	Cover, tank	1	*	24	Sensor, temperature	1	197000-025
7	Heater element	*	*	25	Screw, Phillips head, 8-32 × ½"	8	700170-007
8	Probe assembly with cord and plug	1	406050-100	26	Frame assembly, chassis	1	165541
9	Gasket, 2.50" OD × 1.90" ID	1	309750-004	27	Clip, wire harness	1	405892-001
10	Probe assembly, HT-2 through HT-4	1	406303-005	28	Clip, temperature sensor	1	408251
	Probe assembly, HT-6 through HT-34	1	406303-006	29	Valve assembly, float	1	505310
11	Valve, ¾" electric, 24V	1	505400-001	30	Switch, float, 1/8" NPT	1	408420-002
	Valve, ½" SST ball	1	505000-003	31	Ring, seal, ¼" -18 NPT	1	306365
	Drain, ¼" NPT E.O.S., 24V solenoid SST w/DIN plug (not shown)	1	505086-003	32	Gasket, bulkhead, 1.60 OD × 1.15 ID	1	309750-005
12	Tank weldment	1	*	33	Probe housing, nylon	1	308500
13	Fill valve	1	197000-010	34	Nut, heater .475	1	409601-001
14	Cabinet enclosure	1	330001-001	35	O-ring, 5/8" EPDM No. 016	1	300400-009
15	Hose, ¾" ID	2	307020-002	36	Cap, black	4	409593-002
16	Hose clamp, ¾"	4	700560-075	37	DI orifice, HT-6 through HT-16	1	160229-041
17	Nut assembly, ¼-20, HT-2 through HT-4	4	700650		DI orifice, HT-21 through HT-34	1	160229-052
	Nut assembly, ¼-20, HT-6 through HT-34	2	700650	38	Bulkhead nut	1	162721-002
18	Cover, tank gasket, HT-2 through HT-4	1	160695-001	39	Tube weld, low water, short, HT-2 through HT-4	1	167787
	Cover, tank gasket, HT-6 through HT-34	1	160695-002		Tube weld, low water, long, HT-6 through HT-34	1	167788
19	Washer, No. 8 external tooth, pltd	2	700200-003				

* Specify humidifier model and serial numbers when ordering.

SDU-E

Figure 44-1:
SDU-E replacement parts



OM-1503

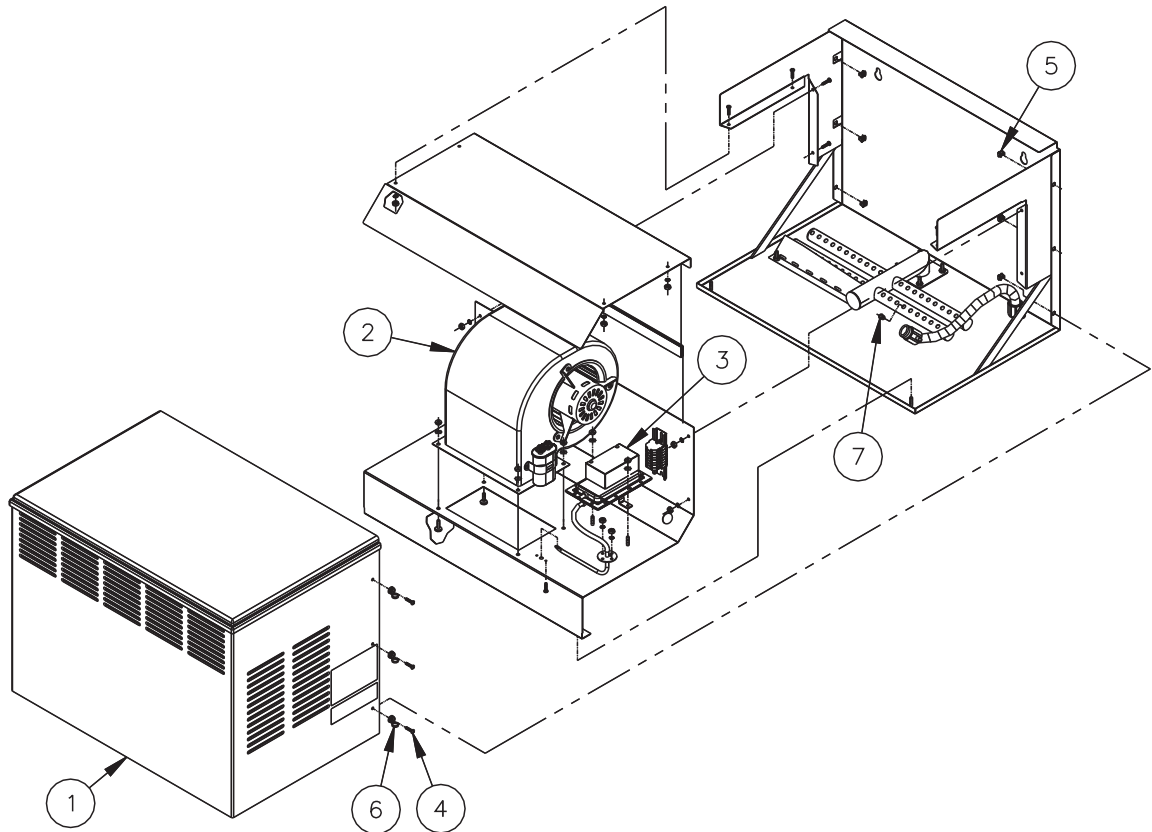
Table 44-1:
SDU-E replacement parts

No.	Description	Qty.	Part number
1	Shroud	1	330002-001
2	Blower, SDU external assembly	1	*
3	Switch, airflow	1	406190
4	Screw, 8-32 × 1½" PHMS Phillips	4	700170-007
5	Nut retainer, 8-32	4	409593-001
6	Cap, black	4	409593-002
7	Dispersion chamber for SDU with 1½" outlet	1	160445-003
	Dispersion chamber for SDU with 2" outlet	1	160445-004

* This is an assembly of multiple parts.

SDU-I

Figure 45-1:
SDU-I replacement parts



OM-1504

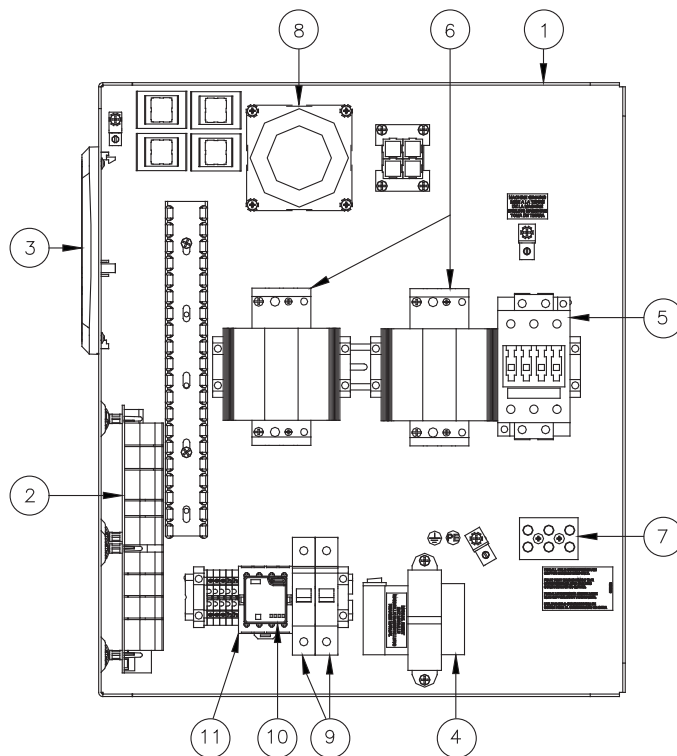
Table 45-1:
SDU-I replacement parts

No.	Description	Qty.	Part number
1	Shroud	1	330001-002
2	Blower, SDU external assembly	1	*
3	Switch, airflow	1	406190
4	Screw, 8-32 × 1½" PHMS Phillips	6	700170-007
5	Nut retainer, 8-32	6	409593-001
6	Cap, black	6	409593-002
7	Tubelet, 0.375" × 0.375" molded	44	310280-006

* This is an assembly of multiple parts.

Subpanel

Figure 46-1:
Humidi-tech subpanel



OM-7651

Table 46-1:
Humidi-tech subpanel

No.	Description	Qty.	Part number	No.	Description	Qty.	Part number
1	Subpanel, barrier, Vapor-logic4	1	120803	7	Terminal block, pressure contact, 3-pole	1	408300-002
2	Main controller, Vapor-logic4	1	408495-001	8	Fan, cooling 24" (610 mm) leads	1	408677-001
3	Display, Vapor-logic4	1	408495-002	9	Circuit breaker, 1-pole, 1.6A	2	406775-007
4	Transformer, 230V/380V/400V/440V 24 SEC 75 VA	1	408985	10	Relay, 24V, DPDT, Finder	1	407900-016
5	Contactors, 35A Siemens	1	407010-001	11	Relay socket, DPDT, without time delay	1	407900-019
	Contactors, 55A Siemens	1	407010-002				
6	SSR, 1-pole, Carlo Gavazzi, 480V	*	408677-002				
	SSR, 1-pole, Carlo Gavazzi, 480V/63A	*	408677-005				
	SSR, 2-pole, Carlo Gavazzi, 480V/50A	*	408677-003				

* Refer to model for correct selection and quantity.

Subpanel

Figure 47-1:
Humidi-tech subpanel with SDU

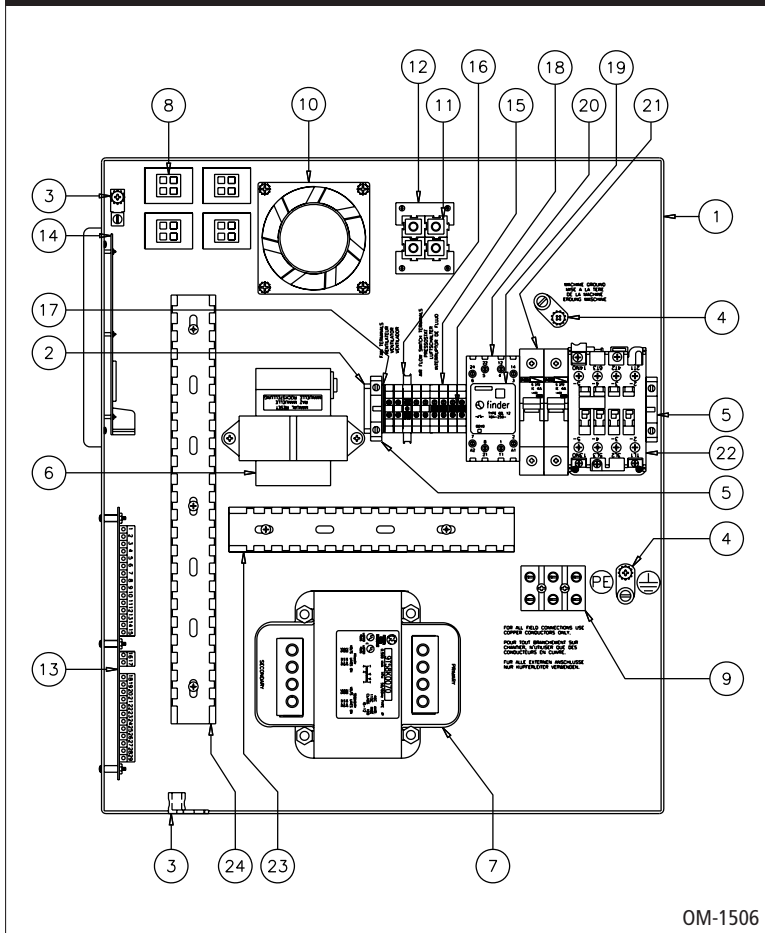


Table 47-1:
Humidi-tech subpanel with SDU

No.	Description	Qty.	Part number
1	Subpanel, barrier	1	120801
2	DIN rail, 8" long	1	167765-008
3	Lug wire	2	409250-003
4	Ground lug, medium	2	409250-027
5	Block, DIN rail terminal end	2	408252-006
7	Transformer 230V/400V, 500 VA	1	408996-011
	Transformer 230V/400V	1	408995
8	Plug, 4-prong female	4	409585-008
9	Terminal block, 3-pole	1	408300-002
	Terminal block, 4-pole	1	408300-003
10	Fan, cooling	1	408677-001
11	Housing, 75 Amp white connector	4	409585-001
12	Plate, plug retainer	2	409585-009
13	Board, Vapor-logic4 main microprocessor	1	408495-001
14	Board, Vapor-logic4 keypad/display	1	408495-002
15	Terminal, DIN rail mount	8	408252-001
16	Terminal, ground	1	408252-010
17	End cap, DIN rail mount	1	408252-005
18	Jumper, marathon terminal	2	408252-009
	Relay, 24V DPDT finder	*	407900-016
19	Relay, 24V 3PDT finder		407900-017
	Relay socket	*	407900-019
	Relay socket, 3PDT without time delay		407900-021
20	Circuit breaker, 4 A, 1-pole	*	406775-009
21	Contactor, 35 A	1	407010-001
	Contactor, 55 A	1	407010-002
22	Channel, wire cover	8"	408999-002
	Channel, wire	8"	408999-001
23	Channel, wire cover	12.5"	408999-002
	Channel, wire	12.5"	408999-001
24	Channel, wire cover	12.5"	408999-002
	Channel, wire	12.5"	408999-001

* Refer to model for correct selection and quantity.

Expect quality from the industry leader

For more than 45 years, DRI-STEEM has been leading the industry with creative and reliable humidification solutions. Our focus on quality is evident in the construction of the Humidi-tech humidifier, which features cleanable, stainless steel construction. DRI-STEEM also leads the industry with a Two-year Limited Warranty and optional extended warranty.

For more information

www.drsteem.com
sales@drsteem.com

For the most recent production information visit our Web site:

www.drsteem.com

DRI-STEEM Corporation

An ISO 9001:2000 certified company

European office:

Marc Briers
Grote Hellekensstraat 54 b
B-3520 Zonhoven
Belgium
+3211823595 (voice)
+3211817948 (fax)
E-mail: marc.briers@drsteem.com

U.S. Headquarters:

14949 Technology Drive
Eden Prairie, MN 55344
800-328-4447 or 952-949-2415
952-229-3200 (fax)

Continuous product improvement is a policy of DRI-STEEM Corporation; therefore, product features and specifications are subject to change without notice.

DRI-STEEM, Dri-calc, Rapid-sorb, Ultra-sorb, Vapor-logic, and Humidi-tech are registered trademarks of DRI-STEEM Corporation and are filed for trademark registration in Canada and the European community.

Drane-kooler is a trademark of DRI-STEEM Corporation.

Product and corporate names used in this document may be trademarks or registered trademarks. They are used for explanation only without intent to infringe.

© 2011 DRI-STEEM Corporation



Form No. HT-IOM-0511
Part No. 890000-206 Rev D

Two-year Limited Warranty

DRI-STEEM Corporation (“DRI-STEEM”) warrants to the original user that its products will be free from defects in materials and workmanship for a period of two (2) years after installation or twenty-seven (27) months from the date DRI-STEEM ships such product, whichever date is the earlier.

If any DRI-STEEM product is found to be defective in material or workmanship during the applicable warranty period, DRI-STEEM’s entire liability, and the purchaser’s sole and exclusive remedy, shall be the repair or replacement of the defective product, or the refund of the purchase price, at DRI-STEEM’s election. DRI-STEEM shall not be liable for any costs or expenses, whether direct or indirect, associated with the installation, removal or reinstallation of any defective product. The Limited Warranty does not include cylinder replacement for electrode steam humidifiers.

DRI-STEEM’s Limited Warranty shall not be effective or actionable unless there is compliance with all installation and operating instructions furnished by DRI-STEEM, or if the products have been modified or altered without the written consent of DRI-STEEM, or if such products have been subject to accident, misuse, mishandling, tampering, negligence or improper maintenance. Any warranty claim must be submitted to DRI-STEEM in writing within the stated warranty period. Defective parts may be required to be returned to DRI-STEEM.

DRI-STEEM’s Limited Warranty is made in lieu of, and DRI-STEEM disclaims all other warranties, whether express or implied, including but not limited to any IMPLIED WARRANTY OF MERCHANTABILITY, ANY IMPLIED WARRANTY OF FITNESS FOR A PARTICULAR PURPOSE, any implied warranty arising out of a course of dealing or of performance, custom or usage of trade.

DRI-STEEM SHALL NOT, UNDER ANY CIRCUMSTANCES BE LIABLE FOR ANY DIRECT, INDIRECT, INCIDENTAL, SPECIAL OR CONSEQUENTIAL DAMAGES (INCLUDING, BUT NOT LIMITED TO, LOSS OF PROFITS, REVENUE OR BUSINESS) OR DAMAGE OR INJURY TO PERSONS OR PROPERTY IN ANY WAY RELATED TO THE MANUFACTURE OR THE USE OF ITS PRODUCTS. The exclusion applies regardless of whether such damages are sought based on breach of warranty, breach of contract, negligence, strict liability in tort, or any other legal theory, even if DRI-STEEM has notice of the possibility of such damages.

By purchasing DRI-STEEM’s products, the purchaser agrees to the terms and conditions of this Limited Warranty.

Extended warranty

The original user may extend the term of the DRI-STEEM Limited Warranty for a limited number of months past the initial applicable warranty period and term provided in the first paragraph of this Limited Warranty. All the terms and conditions of the Limited Warranty during the initial applicable warranty period and term shall apply during any extended term. An extended warranty term of an additional twelve (12) months or twenty four (24) months of coverage may be purchased. The extended warranty term may be purchased until eighteen (18) months after the product is shipped, after which time no extended warranties are available.

Any extension of the Limited Warranty under this program must be in writing, signed by DRI-STEEM, and paid for in full by the purchaser.

