

# Advantys STB Ethernet Modbus TCP/IP Network Interface Applications Guide

890USE17700

Version 1.0

31003688 00



**Telemecanique**



---

# Table of Contents



---

	<b>Safety Information</b> .....	<b>7</b>
	<b>About the Book</b> .....	<b>9</b>
<b>Chapter 1</b>	<b>Introduction</b> .....	<b>11</b>
	At a Glance .....	11
	What Is a Network Interface Module? .....	12
	What Is Advantys STB? .....	15
	STB NIP 2212 Product Overview .....	19
	Ethernet Communications and Connectivity .....	21
<b>Chapter 2</b>	<b>The STB NIP 2212 NIM</b> .....	<b>23</b>
	At a Glance .....	23
	External Features of the STB NIP 2212 .....	24
	STB NIP 2212 Network Interface .....	26
	Rotary Switches .....	28
	LED Indicators .....	30
	The CFG Interface .....	33
	The Power Supply Interface .....	35
	Logic Power .....	37
	Selecting a Source Power Supply for the Island's Logic Power Bus .....	39
	Module Specifications .....	42
<b>Chapter 3</b>	<b>Configuring the Island Bus</b> .....	<b>45</b>
	At a Glance .....	45
	Auto-Addressing .....	46
	Auto-Configuration .....	49
	Installing the STB XMP 4440 Optional Removable Memory Card .....	50
	Using the STB XMP 4440 Optional Removable Memory Card to Configure the Island Bus .....	53
	The RST Button .....	55
	RST Functionality .....	56

---

<b>Chapter 4</b>	<b>IP Parameters</b>	<b>59</b>
	At a Glance	59
	How the STB NIP 2212 Obtains IP Parameters	60
	The IP Address Assignment Process	63
<b>Chapter 5</b>	<b>STB NIP 2212 Web Server</b>	<b>65</b>
	At a Glance	65
5.1	Introduction to the Embedded Web Server	66
	At a Glance	66
	About the Embedded Web Server	67
	Properties Web Page	70
5.2	Web Server Configuration Options	71
	At a Glance	71
	Configuration Web Page	72
	Configuring an IP Address for the STB NIP 2212	73
	Configuring Master Controllers	78
	Master Configurator Web Page	80
	Configuring a Role Name	83
5.3	Web Server Security	86
	At a Glance	86
	Web Access Password Protection	87
	Configuration Password Protection	90
5.4	Web Server Diagnostic Options	92
	At a Glance	92
	Diagnostics Web Page	93
	Ethernet Statistics	94
	STB NIP 2212 Registers Web Page	95
	I/O Data Values Web Page	97
	Island Configuration Web Page	99
	Island Parameters Web Page	100
	Error Log Web Page	101
5.5	SNMP Services	103
	At a Glance	103
	SNMP Device Management	104
	Configure SNMP Web Page	106
	About the Schneider Private MIBs	108
	Transparent Factory Ethernet (TFE) MIB Subtree	110
	Port502 Messaging Subtree	111
	Web MIB Subtree	112
	Equipment Profiles Subtree	113

---

<b>Chapter 6</b>	<b>Data Exchange</b> .....	<b>115</b>
	At a Glance .....	115
	Data Exchange with the STB NIP 2212 .....	116
	Reading Diagnostic Data .....	125
	Modbus Commands Supported by the STB NIP 2212 .....	133
<b>Chapter 7</b>	<b>Connection Example</b> .....	<b>137</b>
	At a Glance .....	137
	Introduction .....	138
	Network Architecture .....	139
	Sample Configuration .....	141
	Modbus Functions Supported by the STB NIP 2212 .....	145
<b>Chapter 8</b>	<b>Advanced Configuration Features</b> .....	<b>149</b>
	At a Glance .....	149
	STB NIP 2212 Configurable Parameters .....	150
	Configuring Mandatory Modules .....	154
	Prioritizing a Module .....	156
	What Is a Reflex Action? .....	157
	Island Fallback Scenarios .....	162
	Saving Configuration Data .....	164
	Protecting Configuration Data .....	165
	A Modbus View of the Island's Data Image .....	166
	The Island's Process Image Blocks .....	169
	The HMI Blocks in the Island Data Image .....	172
<b>Glossary</b>	.....	<b>175</b>
<b>Index</b>	.....	<b>191</b>

---

---

## Safety Information

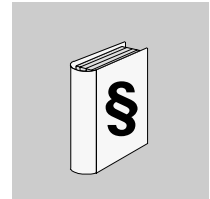

---

### Important Information

#### NOTICE

Read these instructions carefully, and look at the equipment to become familiar with the device before trying to install, operate, or maintain it. The following special messages may appear throughout this documentation or on the equipment to warn of potential hazards or to call attention to information that clarifies or simplifies a procedure.



The addition of this symbol to a Danger or Warning safety label indicates that an electrical hazard exists, which will result in personal injury if the instructions are not followed.



This is the safety alert symbol. It is used to alert you to potential personal injury hazards. Obey all safety messages that follow this symbol to avoid possible injury or death.



### DANGER

DANGER indicates an imminently hazardous situation, which, if not avoided, **will result** in death, serious injury, or equipment damage.



### WARNING

WARNING indicates a potentially hazardous situation, which, if not avoided, **can result** in death, serious injury, or equipment damage.



### CAUTION

CAUTION indicates a potentially hazardous situation, which, if not avoided, **can result** in injury or equipment damage.

---

**PLEASE NOTE**

All pertinent state, regional, and local safety regulations must be observed when installing and using this product. For reasons of safety and to ensure compliance with documented system data, only the manufacturer should perform repairs to components.

When controllers are used for applications with technical safety requirements, please follow the relevant instructions.

No responsibility is assumed by Schneider Electric for any consequences arising out of the use of this material. This document is not intended as an instruction manual for untrained persons.

---



---

## About the Book

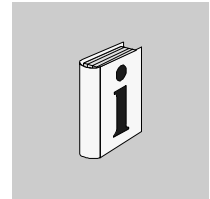

---

### At a Glance

**Document Scope** This *Guide* describes the common hardware and software features of the Advantys STB network interface modules (NIMs) and those that are specific to the STB NIP 2212. The specific features enable an Advantys STB island to function as a node on an Ethernet local area network (LAN) and, in turn, the Internet, or, indirectly, a wide area network (WAN). The Ethernet LAN on which an STB NIP 2212 island resides uses Transport Control Protocol/Internet Protocol (TCP/IP) as its transport layer. The Modbus protocol runs over the TCP/IP layer. This way, an Ethernet host device can control an island with Modbus commands. The Modbus protocol allows devices that can connect only to the RS-232 port on other Advantys STB NIMs to connect to the STB NIP 2212's fieldbus port, too.

**Note:** This *Guide* uses the module name STB NIP 2212 to introduce a feature specific to the Ethernet NIM.

The following information about Advantys STB NIMs in general and the STB NIP 2212 in particular appears in this *Guide*:

- its role as the Advantys STB Ethernet gateway
- the NIM's integrated power supply and its role in the distribution of logic power across the island bus
- common external interfaces:
  - the two-pin connector to an external SELV-rated power supply
  - RS-232 interface to optional devices, including the Advantys configuration software and a human-machine interface (HMI) operator panel
- the optional removable memory card
- advanced configuration features, such as island fallback scenarios
- STB NIP 2212 specific features, including its global connectivity capabilities
- how to configure an STB NIP 2212 with IP parameters
- how to connect the STB NIP 2212 to an Ethernet network
- STB NIP 2212 web-based configuration and troubleshooting features
- Simple Network Management Protocol (SNMP) device management services

### Who Should Use This Manual?

This manual is intended to support the customer who has installed the Advantys STB island bus on an Ethernet LAN and needs to understand the STB NIP 2212's local and remote communications capabilities. This manual assumes familiarity with the Modbus protocol.

---

### Validity Note

The data and illustrations found in this book are not binding. We reserve the right to modify our products in line with our policy of continuous product development. The information in this document is subject to change without notice and should not be construed as a commitment by Schneider Electric.

---

### Related Documents

Title of Documentation	Reference Number
Advantys STB System Planning and Installation Guide	890USE17100
Advantys STB Hardware Components Reference Guide	890USE17200
Advantys STB Configuration Software Quick Start Guide	890USE18000
Advantys STB Reflex Actions Reference Guide	890USE18300
Transparent Factory Network Design and Cabling Guide	490USE13400

---

### Product Related Warnings

Schneider Electric assumes no responsibility for any errors that may appear in this document. If you have any suggestions for improvements or amendments or have found errors in this publication, please notify us.

No part of this document may be reproduced in any form or by any means, electronic or mechanical, including photocopying, without express written permission of Schneider Electric. All rights reserved. Copyright 2003.

All pertinent state, regional, and local safety regulations must be observed when installing and using this product. For reasons of safety and to assure compliance with documented system data, only the manufacturer should perform repairs to components.

When controllers are used for applications with technical safety requirements, please follow the relevant instructions.

Failure to use Schneider Electric software or approved software with our hardware products may result in injury, harm, or improper operating results.

Failure to observe this product related warning can result in injury or equipment damage.

---

### User Comments

We welcome your comments about this document. You can reach us by e-mail at [TECHCOMM@modicon.com](mailto:TECHCOMM@modicon.com)

---

---

# Introduction



---

## At a Glance

### Introduction

This chapter provides a general overview of the network interface module (NIM) and the Advantys STB island bus. The chapter concludes with an introduction to the specific features of the STB NIP 2212 Ethernet Modbus TCP/IP NIM.

### What's in this Chapter?

This chapter contains the following topics:

Topic	Page
What Is a Network Interface Module?	12
What Is Advantys STB?	15
STB NIP 2212 Product Overview	19
Ethernet Communications and Connectivity	21

---

## What Is a Network Interface Module?

---

### Purpose

Every island requires a network interface module (NIM) in the leftmost location of the primary segment. Physically, the NIM is the first (leftmost) module on the island bus. Functionally, it is the gateway to the island bus—all communications to and from the island bus pass through the NIM. The NIM also has an integrated power supply that provides logic power to the island modules.

---

### The Fieldbus Network

An island bus is a node of distributed I/O on an open fieldbus network, and the NIM is the island's interface to that network. The NIM supports data transfers over the fieldbus network between the island and the fieldbus master.

The physical design of the NIM makes it compatible with both an Advantys STB island and your specific fieldbus master. Whereas the fieldbus connector on each NIM type may differ, the location on the module front panel is essentially the same. Other NIM connectors, such as the power supply interface and the CFG interface (See *The CFG Interface*, p. 33), are identical for all NIM types.

---

### Communications Roles

NIM-supported communications include:

Function	Role
data exchange	The NIM manages the exchange of input and output data between the island and the fieldbus master. Input data, stored in native island bus format, is converted to a fieldbus-specific format that can be read by the fieldbus master. Output data written to the NIM by the master is sent across the island bus to update the output modules and is automatically reformatted.
configuration services	Custom services can be performed by the Advantys configuration software. These services include changing the operating parameters of the I/O modules, fine-tuning island bus performance, and configuring reflex actions. The Advantys configuration software runs on a computer attached to the NIM's CFG port.
human-machine interface (HMI) operations	An HMI panel can be configured as an input and/or output device on the island bus. As an input device, it can write data that can be received by the fieldbus master; as an output device, it can receive updated data from the fieldbus master. The HMI can also monitor island status, data, and diagnostic information. The HMI panel must be attached to the NIM's CFG port.

---

**Integrated Power Supply**

The NIM's built-in 24-to-5 VDC power supply provides logic power to the I/O modules on the primary segment of the island bus. The power supply requires a 24 VDC external power source. It converts the 24 VDC to 5 V of logic power, providing 1.2 A of current to the island. Individual STB I/O modules in an island segment generally draw a current load of between 50 and 90 mA. (Consult the *Advantys STB Hardware Components Reference Guide* [890 USE 172] for a particular module's specifications.) If the current drawn by the I/O modules totals more than 1.2 A, additional STB power supplies need to be installed to support the load.

The NIM delivers the logic power signal to the primary segment only. Special STB XBE 1200 beginning-of-segment (BOS) modules, located in the first slot of each extension segment, have their own built-in power supplies, which will provide logic power to the STB I/O modules in the extension segments. Each BOS module that you install requires 24 VDC from an external power supply.

---

**Structural Overview**

The following figure illustrates the multiple roles of the NIM. The figure provides a network view and a physical representation of the island bus:

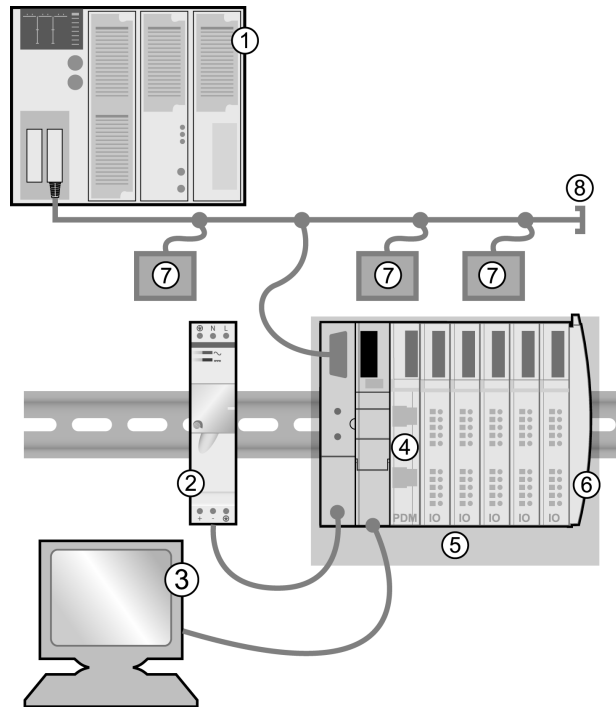

- 1 fieldbus master
- 2 external 24 VDC power supply, the source for logic power on the island
- 3 external device connecting to the CFG port—a computer running the Advantys configuration software or an HMI panel
- 4 power distribution module (PDM)
- 5 island node
- 6 island bus terminator plate
- 7 other nodes on the fieldbus network
- 8 fieldbus network terminator (if required)

## What Is Advantys STB?

---

### Introduction

Advantys STB is an assembly of distributed I/O, power, and other modules that function together as an island node on an open fieldbus network. Advantys STB delivers a highly modular and versatile slice I/O solution for the manufacturing industry, with a migration path to the process industry.

Advantys STB lets you design an island of distributed I/O where the I/O modules can be installed as close as possible to the mechanical field devices that they control. This integrated concept is known as *mechatronics*.

---

### Island Bus I/O

An Advantys STB island can support as many as 32 I/O modules. These modules may be Advantys STB I/O modules, preferred modules, and standard CANopen devices.

---

### The Primary Segment

STB I/O modules on an island may be interconnected in groups called segments. Every island has at least one segment, called the *primary segment*—it is always the first segment on the island bus. The NIM is the first module in the primary segment. The primary segment must contain at least one Advantys STB I/O module and can support an I/O load of up to 1.2 A. The segment also contains one or more power distribution modules (PDMs), which distribute field power to the I/O modules.

---

## Extension Segments

Advantys STB I/O modules that do not reside in the primary segment can be installed in *extension segments*. Extension segments are optional segments that enable an island to be a truly distributed I/O system. The island bus can support as many as six extension segments.

Special extension modules and extension cables are used to connect segments in a series. The extension modules are:

- the STB XBE 1000 EOS module, which is the last module in a segment if the island bus is extended
- the STB XBE 1200 BOS module, which is the first module in an extension segment

The BOS module has a built-in 24-to-5 VDC power supply similar to the NIM. The BOS power supply also provides 1.2 A of logic power to the STB I/O modules in an extension segment.

Extension modules are connected by lengths of STB XCA 100x cable that extend the island communication bus from the previous segment to the next BOS module:

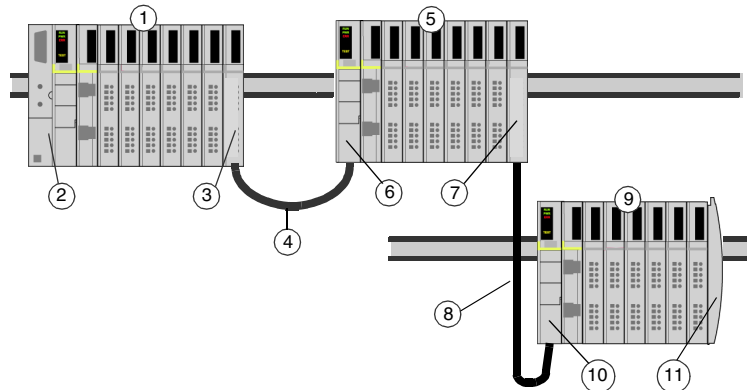

- 1 primary segment
- 2 NIM
- 3 STB XBE 1000 EOS bus extension module
- 4 1 m length STB XCA 1002 bus extension cable
- 5 first extension segment
- 6 STB XBE 1200 BOS bus extension module for the first extension segment
- 7 another STB XBE 1000 EOS extension module
- 8 4.5 m length STB XCA 1003 bus extension cable
- 9 second extension segment
- 10 STB XBE 1200 BOS bus extension module for the second extension segment
- 11 STB XMP 1100 termination plate

Bus extension cables are available in various lengths, ranging from 0.3 m (1 ft) to 14.0 m (45.9 ft).



## Preferred Modules

An island bus can also support those auto-addressable modules referred to as *preferred modules*. Preferred modules do not mount in segments, but they do count as part of the 32-module maximum system limit.

**Note:** If you want to include preferred modules in your island, you need to configure the island using the Advantys configuration software.

A preferred module can connect to an island bus segment via an STB XBE 1000 EOS module and a length of STB XCA 100x bus extension cable. Each preferred module has two IEEE 1394-style cable connectors, one to receive the island bus signals and the other to transmit them to the next module in the series. Preferred modules are also equipped with termination, which must be enabled if a preferred module is the last device on the island bus and must be disabled if other modules follow the preferred device on the island bus.

Preferred modules can be chained to one another in a series, or they can connect to Advantys STB segments. As shown in the following figure, a preferred module passes the island bus communications signal from the primary segment to an extension segment of Advantys STB I/O modules:

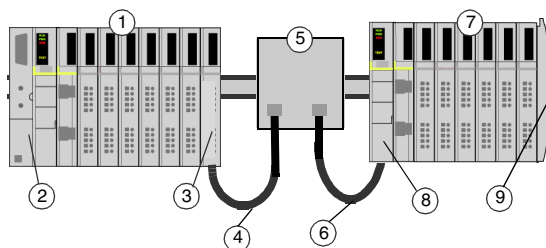

- 1 primary segment
- 2 NIM
- 3 STB XBE 1000 EOS bus extension module
- 4 1 m length STB XCA 1002 bus extension cable
- 5 preferred module
- 6 1 m length STB XCA 1002 bus extension cable
- 7 extension segment of Advantys STB I/O modules
- 8 STB XBE 1200 BOS bus extension module for the extension segment
- 9 STB XMP 1100 termination plate

## Standard CANopen Devices

You may also install one or more standard CANopen devices on an island. These devices are not auto-addressable, and they must be installed at the end of the island bus. If you want to install standard CANopen devices on an island, you need to use an STB XBE 2100 CANopen extension module as the last module in the last segment.

**Note:** If you want to include standard CANopen devices in your island, you need to configure the island using the Advantys configuration software.

Because standard CANopen devices cannot be auto-addressed on the island bus, they must be addressed using physical addressing mechanisms on the devices. Because standard CANopen devices must be installed at the end of the island, the last device on the island bus must be terminated with 120  $\Omega$ .

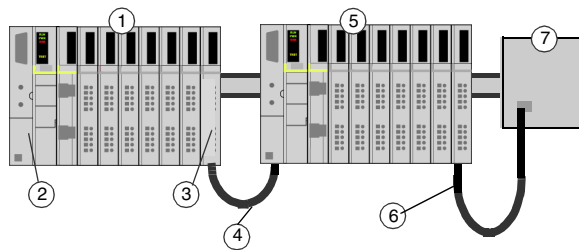

- 1 primary segment
- 2 NIM
- 3 STB XBE 1000 EOS bus extension module
- 4 1 m length STB XCA 1002 bus extension cable
- 5 extension segment
- 6 typical CANopen cable
- 7 standard CANopen device with 120  $\Omega$  termination

## Length of the Island Bus

The maximum length of an island bus—the maximum distance between the NIM and the last device on the island—is 15 m (49.2 ft). This length must take into account the extension cables between segments, extension cables between preferred modules, and the space consumed by the devices themselves.

---

## STB NIP 2212 Product Overview

---

### Introduction

An Advantys STB island bus configured with an STB NIP 2212 network interface module (NIM) can function transparently as a node on an Ethernet local area network (LAN), or on the Internet. It can function, indirectly, as a node on a wide area network (WAN). Similarly to the other Advantys STB NIMs, the STB NIP 2212 can be a slave device. In the case of the STB NIP 2212, the manager is an Ethernet host.

Because the STB NIP 2212 enables an Advantys STB island to be a node on the Ethernet, it is often referred to as the *Ethernet NIM*.

---

### Ethernet and Internet Connectivity

The Transmission Control Protocol/Internet Protocol (TCP/IP) is the transport layer for the Ethernet LAN on which the STB NIP 2212 Advantys STB island resides. This network architecture enables communications with a wide range of Ethernet TCP/IP control products, such as Programmable Logic Controllers (PLCs), industrial computers, motion controllers, host computers, and operator control stations.

---

### Embedded Web Server

The STB NIP 2212 includes an embedded web server (See *STB NIP 2212 Web Server*, p. 65), which is a web browser-enabled application. It allows authorized users worldwide to view configuration and diagnostic data for the STB NIP 2212 (See *Web Access Password Protection*, p. 87). (Users with additional authorization (See *Configuration Password Protection*, p. 90) can write data to the STB NIP 2212.)

---

### Internet Applications

The STB NIP 2212 is configured for the following Internet applications:

- Hypertext Transfer Protocol (HTTP) embedded web server
    - Port 80 service access point (SAP)
    - browser based IP configuration and troubleshooting
  - Simple Network Management Protocol (SNMP)—allows remote network management of the STB NIP 2212
    - Port 161 service access point (SAP)
    - enables remote network management (NMT) of the STB NIP 2212
- 

### Open Modbus

An open implementation of the proprietary Modbus protocol runs over TCP/IP on the Ethernet LAN on which the STB NIP 2212 resides. The fieldbus (Ethernet) port (See *STB NIP 2212 Network Interface*, p. 26) on the STB NIP 2212 is configured for Port 502 SAP functionality. Port 502 is the well-known port for Modbus over TCP that was assigned to Schneider Electric by the Internet Authority (IANA).

---

**Conformance to NIM Standards**

The STB NIP 2212 is designed to support all of the standard Advantys STB NIM features and functions (See *What Is a Network Interface Module?*, p. 12). Because an STB NIP 2212 runs Modbus as its fieldbus protocol, a device running the Advantys configuration software or a human-machine interface (HMI) can attach to either its fieldbus (Ethernet) port (See *STB NIP 2212 Network Interface*, p. 26) or its CFG port (See *The CFG Interface*, p. 33).

---

**Ethernet Host**

PLCs and personal computers (PCs) configured with the Modbus protocol are suitable upstream Ethernet hosts to islands using the STB NIP 2212 as their gateway. The Ethernet host can be local or remote.

---

## Ethernet Communications and Connectivity

---

<b>Introduction</b>	<p>The STB NIP 2212 allows the Advantys STB island to function as a node on an Ethernet local area network (LAN). Ethernet is an open local (communications) network that enables the interconnectivity of all levels of manufacturing operations from the plant's office to the sensors and actuators on its floor.</p>
<b>Conformance</b>	<p>The STB NIP 2212 is located on a 10Base-T LAN. The 10Base-T standard is defined by the IEEE 802.3 Ethernet specification. Contention for 10Base-T networks is resolved by using Carrier Sense Multiple Access with Collision Detect (CSMA/CD).</p>
<b>Transmission Rate</b>	<p>An STB NIP 2212 island node resides on a <i>baseband</i> network with a transmission rate of 10 Mbit/s.</p>
<b>Frame Format</b>	<p>The STB NIP 2212 supports both Ethernet II and IEEE 802.3 frame formats; Ethernet II is the default frame type.</p>

---



---

# The STB NIP 2212 NIM

# 2

---

## At a Glance

### Introduction

This chapter describes the external features of the STB NIP 2212, including its Ethernet port, network cable requirements, and power requirements.

### What's in this Chapter?

This chapter contains the following topics:

Topic	Page
External Features of the STB NIP 2212	24
STB NIP 2212 Network Interface	26
Rotary Switches	28
LED Indicators	30
The CFG Interface	33
The Power Supply Interface	35
Logic Power	37
Selecting a Source Power Supply for the Island's Logic Power Bus	39
Module Specifications	42

## External Features of the STB NIP 2212

---

### Summary of Features

The following figure indicates where the physical features critical to STB NIP 2212 NIM operations are located:

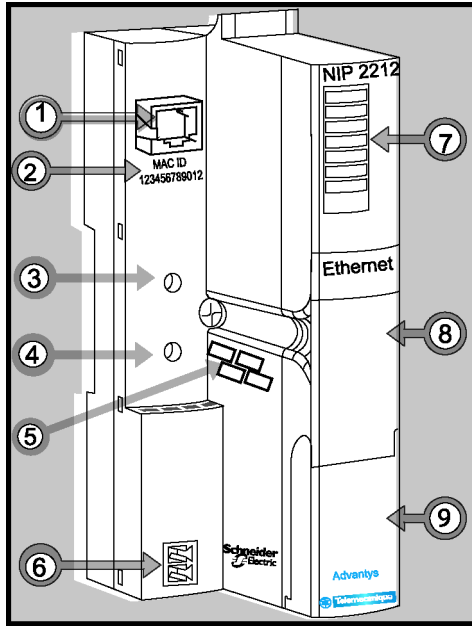



The physical features of the STB NIP 2212 are described briefly in the following table:

Feature		Function
1	Ethernet interface	An RJ-45 (See <i>STB NIP 2212 Network Interface, p. 26</i> ) connector is used to connect the NIM and the island bus to an Ethernet LAN network.
2	MAC ID	48-bit, unique network ID hard-coded in the STB NIP 2212 when manufactured.
3	upper rotary switch	The rotary switches (See <i>Physical Description, p. 28</i> ) used together specify a role name for the STB NIP 2212. Alternatively, the lower rotary switch can be used to direct the STB NIP 2212 to use its MAC-based default IP address (See <i>Summary of Valid IP Address Settings, p. 29</i> ) or to obtain its IP parameters from a BootP server or from the STB NIP 2212 web site (See <i>About the Embedded Web Server, p. 67</i> ).
4	lower rotary switch	
5	space provided to record IP address	Write the IP address that you assign to this STB NIP 2212 here.
6	power supply interface	A two-pin connector used to connect an external 24 VDC power supply (See <i>Selecting a Source Power Supply for the Island's Logic Power Bus, p. 39</i> ) to the NIM.
7	LED array	Colored LEDs (See <i>LED Indicators, p. 30</i> ) use various patterns to visually indicate the operational status of the island bus, activity on the NIM, and the status of communications to the island over the Ethernet LAN.
8	removable memory card drawer	A plastic drawer in which a removable memory card (See <i>Installing the STB XMP 4440 Optional Removable Memory Card, p. 50</i> ) can be seated and then inserted into the NIM.
9	CFG port cover	A hinged flap on the NIM's front panel that covers the CFG interface (See <i>The CFG Interface, p. 33</i> ) and the RST button (See <i>The RST Button, p. 55</i> ).

## STB NIP 2212 Network Interface

### Introduction

The fieldbus interface on the STB NIP 2212 is the point of connection between an Advantys STB island and the Ethernet LAN on which the island resides. This fieldbus interface is also called the *Ethernet port*.

The fieldbus interface is a 10Base-T port with an RJ-45 female connector. Category 5 (CAT5) twisted pair electrical wiring, either shielded or unshielded (STP/UTP), is used to connect the STB NIP 2212 to the Ethernet baseband.

**Note:** Because the Ethernet port is configured for Modbus over TCP/IP services (SAP 502), the Advantys configuration software can run over the fieldbus interface on the STB NIP 2212.

### Fieldbus (Ethernet) Port

The interface for 10Base-T connections is located on the front of the STB NIP 2212 NIM toward the top:

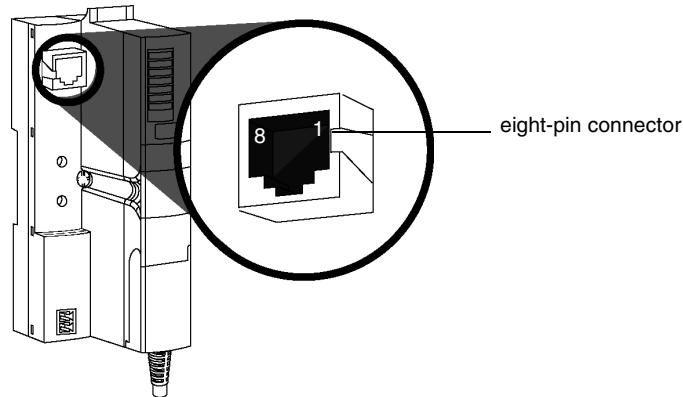

The RJ-45 connector is an eight-pin female connector. The eight pins connect horizontally along the top. Pin 8 has the leftmost position, and pin 1 is the rightmost. The pin-out for the RJ-45 complies with the information in the following table:

Pin	Description
1	tx+
2	tx-
3	rx+
4	reserved
5	reserved
6	rx-
7	reserved
8	reserved

## Communications Cable and Connector

The required communications cable is either shielded (STP) or unshielded (UTP) electrical, twisted pair CAT5 cable. The cable used with the STB NIP 2212 must terminate with an eight-pin male connector.

The CAT5 cable recommended for connecting the STB NIP 2212 to an Ethernet LAN has the following characteristics:

standard	description	max. length	application	data rate	connector to the fieldbus interface
10Base-T	24-gauge, twisted pair	100 m (328 ft)	data transmission	10 Mbits/s	eight-pin male

**Note:** There are many 8-pin male connectors that are compatible with the RJ-45 fieldbus interface on the STB NIP 2212. Refer to the *Transparent Factory Network Design and Cabling Guide* (490 USE 134 00) for a list of approved connectors.

**Note:** The technical specifications for CAT5 cable are defined by FCC Part 68, EIA/TIA-568, TIA TSB-36, and TIA TSB-40.

## About STP/UTP Cabling

Select STP or UTP cable according to the noise level in your environment:

- Use STP cabling in high electrical noise environments.
- UTP cabling is acceptable in low electrical noise environments.

## Rotary Switches

---

### Introduction

The STB NIP 2212 is a single node on an Ethernet LAN and, in turn, the Internet. An STB NIP 2212 must have a unique IP address. The two rotary switches on the NIM provide a simple, easy way to assign an IP address to the STB NIP 2212.

---

### Physical Description

The two rotary switches are positioned one above the other on the front of the STB NIP 2212. The upper switch represents the tens digit, and the lower switch represents the ones digit:

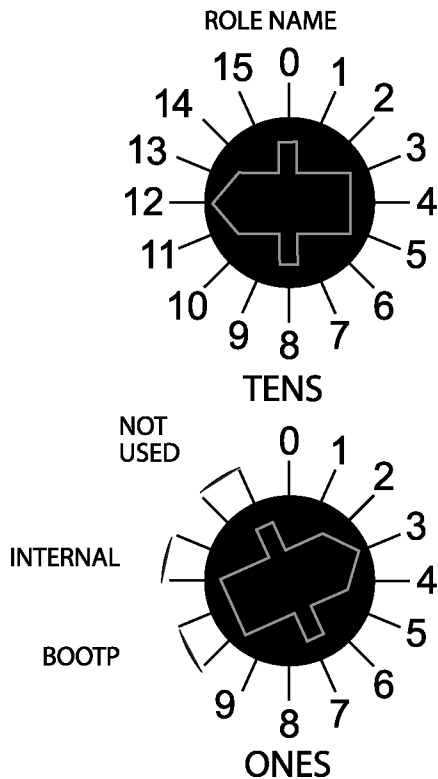

---

**Summary of  
Valid IP Address  
Settings**

Each rotary switch position that you can use to set a valid IP address is marked on the STB NIP 2212 housing (See *Physical Description*, p. 28). The following information summarizes the valid address settings:

- For a switch-set role name, select a numeric value from 00 to 159. You can use both switches:
  - On the upper switch (tens digit), the available settings are 0 to 15.
  - On the lower switch (ones digit), the available settings are 0 to 9.The numeric setting is appended to the STB NIP 2212 part number, e.g., *STBNIP2212\_123*, and a DHCP server assigns it an IP address.
- For a BootP-served IP address (See *Server-Assigned IP Addresses*, p. 62), select either of the two **BOOTP** positions on the bottom switch.
- If you set the bottom switch to either of the two **INTERNAL** positions, the IP address will be assigned by one of the following methods:
  - if the STB NIP 2212 is direct from the factory, it has no software set IP parameters and will use a MAC-based IP address (See *Deriving an IP Address from a Media Access Control (MAC) Address*, p. 61).
  - a fixed IP address using the STB NIP 2212 web configuration pages (See *Web-Based Configuration Options*, p. 72)
  - a web-configured role name (See *Configuring a Role Name*, p. 83) in association with a DHCP server

**Note:** For information about how the STB NIP 2212 prioritizes IP addressing options, refer to the IP parameterization flow chart (See *Determining the IP Address*, p. 63).

**Note:** The STB NIP 2212 requires a valid IP address to communicate on the Ethernet network and with a host. You must power cycle the STB NIP 2212 to configure the STB NIP 2212 with an IP address set with these rotary switches.

---

## LED Indicators

---

### Introduction

Six LEDs on the STB NIP 2212 NIM visually indicate the operational status of the island bus on an Ethernet LAN. The LED array is located toward the top of the NIM front bezel:

- LED 10T ACT (See *Ethernet Communications LEDs*, p. 31) indicates whether the Ethernet LAN and the Ethernet port are healthy and alive.
  - LED LAN ST (See *Ethernet Communications LEDs*, p. 31) indicates events on the Ethernet LAN.
  - LEDs RUN, POWER, ERROR, and TEST indicate activity on the island and/or events on the NIM.
- 

### Description

The illustration shows the six LEDs used by the Advantys STB NIP 2212:

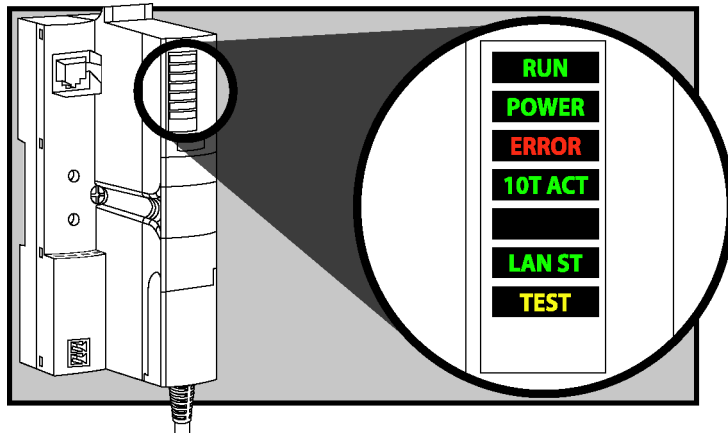

### Ethernet Communications LEDs

The 10T ACT and the STATUS indicate the conditions described in the following table:

Label	Pattern	Meaning
10T ACT (green)	on	The network is alive and healthy.
	off	The network is not alive and not healthy.
LAN ST (green)	steady on	The Ethernet LAN is operational.
	steady off	No MAC address found.
	blinking	Initializing the Ethernet network.
	blink: 3	No link pulse detected.
	blink: 4	Duplicate IP address detected.
	blink: 5	Obtaining IP address (See <i>The IP Address Assignment Process</i> , p. 63).
	blink: 6	Using the default IP address (See <i>Deriving an IP Address from a Media Access Control (MAC) Address</i> , p. 61).

### Advantys STB Communications LEDs

The table that follows describes the island bus condition(s) communicated by the LEDs, and the colors and blink patterns used to indicate each condition.

RUN (green)	ERROR (red)	TEST (yellow)	Meaning
blink: 2	blink: 2	blink: 2	The island is powering up (self test in progress).
off	off	off	The island is initializing—it is not started.
blink: 1	off	off	The island has been put in the pre-operational state by the RST button—it is not started.
		blink: 3	The NIM is reading the contents of the removable memory card (See <i>Using the STB XMP 4440 Optional Removable Memory Card to Configure the Island Bus</i> , p. 53).
		on	The NIM is overwriting its Flash memory with the card's configuration data. (See 1.)
off	blink: 8	off	The contents of the removable memory card is invalid.
blinking (steady)	off	off	The NIM is configuring (See <i>Configuring the Island Bus</i> , p. 45) or auto-configuring (See <i>Auto-Configuration</i> , p. 49) the island bus—the bus is not started.
blinking	off	on	Auto-configuration data is being written to Flash memory. (See 1.)
off	blink: 6	off	The NIM detects no I/O modules on the island bus.
off	blink: 2	off	Configuration mismatch detected after power up—at least one mandatory module does not match; the island bus is not started.

<b>RUN (green)</b>	<b>ERROR (red)</b>	<b>TEST (yellow)</b>	<b>Meaning</b>
off	blink: 2	off	Assignment error—the NIM has detected a module assignment error; the island bus is not started.
	blink: 5		Internal triggering protocol error.
off	blinking (steady)	off	Fatal error—Because of the severity of the error, no further communications with the island bus are possible and the NIM stops the island. The following are fatal errors: <ul style="list-style-type: none"> <li>● significant internal error</li> <li>● module ID error</li> <li>● auto-addressing (See <i>Auto-Addressing</i>, p. 46) failure</li> <li>● mandatory module (See <i>Configuring Mandatory Modules</i>, p. 154) configuration error</li> <li>● process image error</li> <li>● auto-configuration/configuration (See <i>Auto-Configuration</i>, p. 49) error</li> <li>● island bus management error</li> <li>● receive/transmit queue software overrun error</li> </ul>
on	off	off	The island bus is operational.
on	blink: 3	off	At least one standard module does not match—the island bus is operational with a configuration mismatch.
on	blink: 2	off	Serious configuration mismatch (when a module is pulled from a running island)—the island bus is now in pre-operational mode because of one or more mismatched mandatory modules.
blink: 4	off	off	The island bus is stopped (when a module is pulled from a running island)—no further communications with the island are possible.
off	on	off	Fatal error—internal failure.
[any]	[any]	on	Test mode is enabled—the configuration software or an HMI panel can set outputs. (See 2.)
<p><b>1</b> The TEST LED is on temporarily during the Flash overwrite process.</p> <p><b>2</b> The TEST LED is on steadily while the device connected to the CFG port is in control.</p>			



## The CFG Interface

**Purpose** The CFG port is the connection point to the island bus for either a computer running the Advantys configuration software or an HMI panel.

**Physical Description** The CFG interface is a front-accessible RS-232 interface located behind a hinged flap on the bottom front of the NIM:

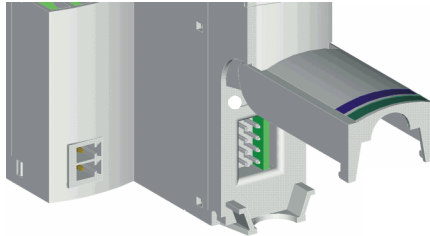

The port uses a male eight-pin HE-13 connector.

**Port Parameters** The CFG port supports the set of communication parameters listed in the following table. If you want to apply any settings other than the factory default values, you must use the Advantys configuration software:

Parameter	Valid Values	Factory Default Settings
bit rate (baud)	2400 / 4800 / 9600 / 19200 / 38400 / 57600	9600
data bits	7/8	8
stop bits	1/2	1
parity	none/odd/even	even
Modbus communications mode	RTU/ASCII	RTU

**Note:** To restore all of the CFG port's communication parameters to their factory default settings, push the RST button (See *The RST Button*, p. 55) on the NIM. Be aware, however, that this action will overwrite all of the island's current configuration values with factory default values. You can also password protect a configuration, thereby putting the island in protected mode (See *Protecting Configuration Data*, p. 165). If you do this, however, the RST button will be disabled and you will not be able to use it to reset the port parameters.

**Connections**

An STB XCA 4002 programming cable must be used to connect the computer running the Advantys configuration software or a Modbus-capable HMI panel to the NIM via the CFG port.

The following table describes the specifications for the programming cable:

<b>Parameter</b>	<b>Description</b>
model	STB XCA 4002
function	connection to device running Advantys configuration software
	connection to HMI panel
communications protocol	Modbus (either RTU or ASCII mode)
cable length	2 m (6.23 ft)
cable connectors	eight-receptacle HE-13 (female) nine-receptacle SUB-D (female)
cable type	multiconductor

---

## The Power Supply Interface

### Introduction

The NIM's built-in power supply requires 24 VDC from an external SELV-rated power source. The connection between the 24 VDC source and the island is the male two-pin connector illustrated below.

### Physical Description

Power from the external 24 VDC supply comes in to the NIM via a two-pin connector located at the bottom left of the module:

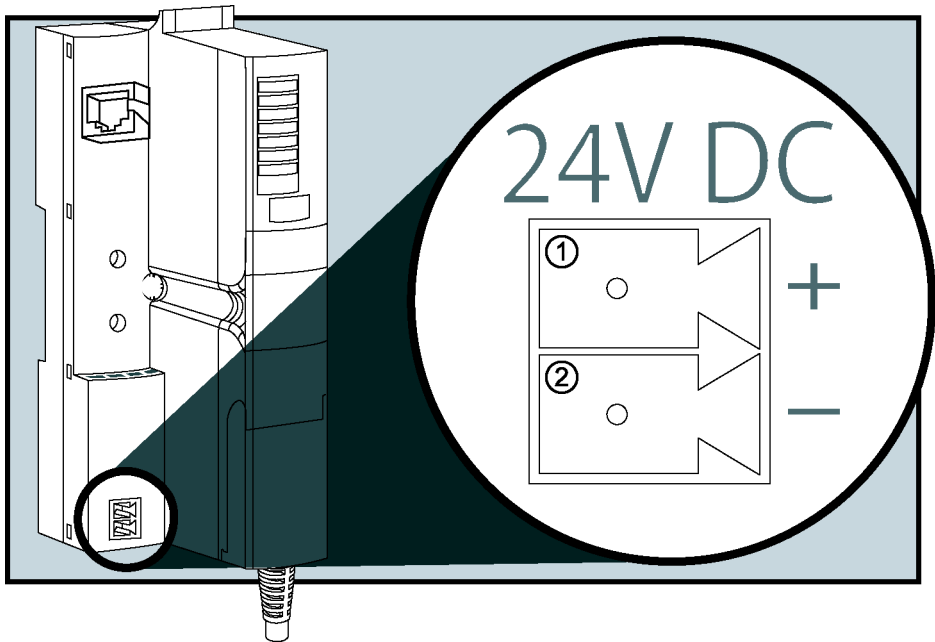

- 1 connector 1–24 VDC
- 2 connector 2–common voltage

## Connectors

Use either:

- a *screw type* power connector, available in a kit of 10 (model STB XTS 1120)
- a *spring clamp* power connector, available in a kit of 10 (model STB XTS 2120)

The following illustrations show two views of each power connector type. A front and back view of the STB XTS 1120 screw type connector is shown on the left, and a front and back view of the STB XTS 2120 spring clamp connector is shown on the right:

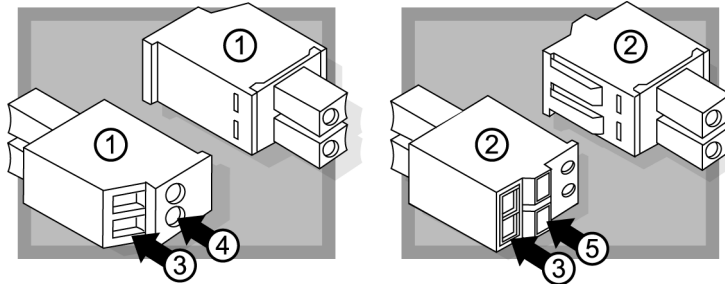

- 1 STB XTS 1120 screw-type power connector
- 2 STB XTS 2120 spring clamp power connector
- 3 wire entry slot
- 4 screw clamp access
- 5 spring clamp actuation button

Each entry slot accepts a wire in the range 0.14 to 1.5 mm<sup>2</sup> (28 to 16 AWG).  
Each connector has a 3.8 mm (0.15 in) pitch between the entry slots.

---

---

## Logic Power

---

### Introduction

Logic power is a 5 VDC power signal on the island bus that the I/O modules require for internal processing. The NIM has a built-in power supply that provides logic power. The NIM sends the 5 V logic power signal across the island bus to support the modules in the primary segment.

---

### External Source Power

Input from an external 24 VDC power supply (See *Characteristics of the External Power Supply, p. 39*) is needed as the source power for the NIM's built-in power supply. The NIM's built-in power supply converts the incoming 24 V to 5 V of logic power. The external supply must be rated *safety extra low voltage* (SELV-rated).

	<b>CAUTION</b>
	<b>IMPROPER GALVANIC ISOLATION</b> The power components are not galvanically isolated. They are intended for use only in systems designed to provide SELV isolation between the supply inputs or outputs and the load devices or system power bus. You must use SELV-rated supplies to provide 24 VDC source power to the island. <b>Failure to follow this precaution can result in injury or equipment damage.</b>

---

### Logic Power Flow

The figure below shows how the NIM's integrated power supply generates logic power and sends it across the primary segment:

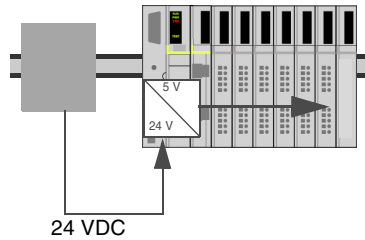

The figure below shows how the 24 VDC signal is distributed to an extension segment across the island:

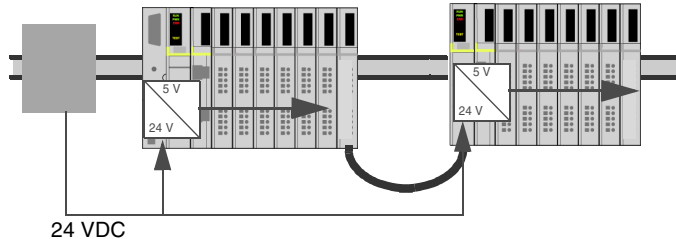

The logic power signal is terminated in the STB XBE 1000 module at the end of the segment (EOS).

---

### Island Bus Loads

The built-in power supply produces 1.2 A of current for the island bus. Individual STB I/O modules generally draw a current load of between 50 and 90 mA. (Consult the *Advantys STB Hardware Components Reference Guide* (890 USE 172 00) for a particular module's specifications.) If the current drawn by the I/O modules totals more than 1.2 A, additional STB power supplies need to be installed to support the load.

---

## Selecting a Source Power Supply for the Island's Logic Power Bus

### Logic Power Requirements

An external 24 VDC power supply is needed as the source for logic power to the island bus. The external power supply connects to the island's NIM. This external supply provides the 24 V input to the built-in 5 V power supply in the NIM. The NIM delivers the logic power signal to the primary segment only. Special STB XBE 1200 beginning-of-segment (BOS) modules, located in the first slot of each extension segment, have their own built-in power supplies, which will provide logic power to the STB I/O modules in the extension segments. Each BOS module that you install requires 24 VDC from an external power supply.

### Characteristics of the External Power Supply

The external power supply needs to deliver 24 VDC source power to the island. The supply that you select can have a low range limit of 19.2 VDC and a high range limit of 30 VDC. The external supply must be rated *safety extra low voltage* (SELV-rated). The SELV-rating means that SELV isolation is provided between the power supply's inputs and outputs, the power bus, and the devices connected to the island bus. Under normal or single-fault conditions the voltage between any two accessible parts, or between an accessible part and the protective earth (PE) terminal for Class 1 equipment, will not exceed a safe value (60 VDC max.).

	<b>CAUTION</b>
	<p><b>IMPROPER GALVANIC ISOLATION</b></p> <p>The power components are not galvanically isolated. They are intended for use only in systems designed to provide SELV isolation between the supply inputs or outputs and the load devices or system power bus. You must use SELV-rated supplies to provide 24 VDC source power to the island.</p> <p><b>Failure to follow this precaution can result in injury or equipment damage.</b></p>

### Calculating the Wattage Requirement

The amount of power (See *Logic Power Flow*, p. 38) that the external power supply must deliver is a function of the number of modules and the number of built-in power supplies installed on the island.

The external supply needs to provide 13 W of power for the NIM and 13 W for each additional STB power supply (like an STB XBE 1200 BOS module). For example, a system with one NIM in the primary segment and one BOS module in an extension segment would require 26 W of power.

For example, the figure below shows an extended island:

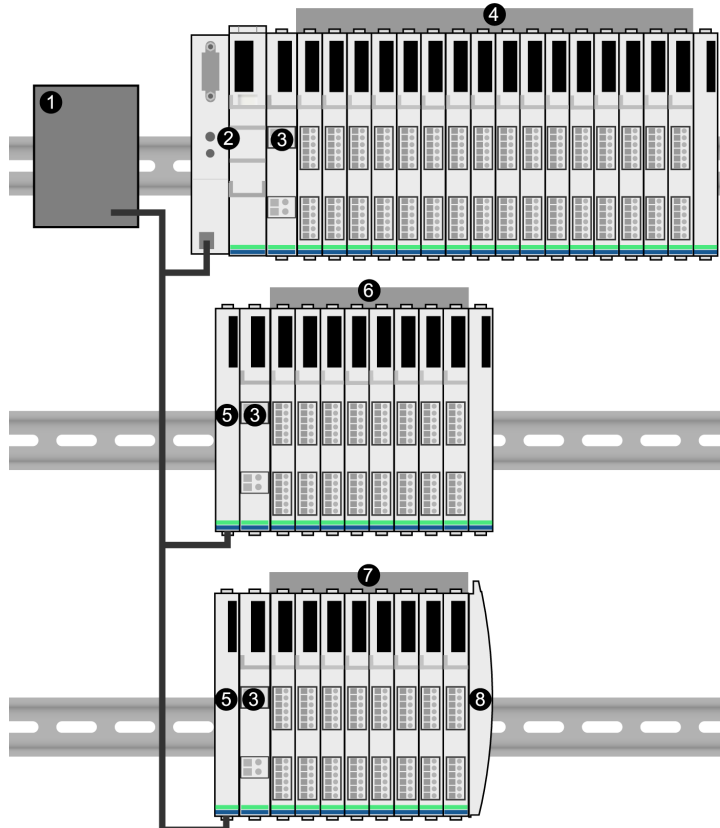

- 1 24 VDC source power supply
- 2 NIM
- 3 PDM
- 4 primary segment I/O modules
- 5 BOS module
- 6 first extension segment I/O modules
- 7 second extension segment I/O modules
- 8 island bus terminator plate



---

The extended island bus contains three built-in power supplies:

- the supply built into the NIM, which resides in the leftmost location of the primary segment
- a power supply built into each of the STB XBE 1200 BOS extension modules, which reside in the leftmost location of the two extension segments

In the figure, the external supply would provide 13 W of power for the NIM plus 13 W for each of the two BOS modules in the extension segments (for a total of 39 W).

<p><b>Note:</b> If the 24 VDC source power supply also supplies field voltage to a power distribution module (PDM), you must add the field load to your wattage calculation. For 24 VDC loads, the calculation is simply <i>amps x volts = watts</i>.</p>
---

### Suggested Devices

---

The external power supply is generally enclosed in the same cabinet as the island. Usually the external power supply is a DIN rail-mountable unit.

For installations that require 72 W or less from a 24 VDC source power supply, we recommend a device such as the ABL7 RE2403 Phaseo power supply from Telemecanique, distributed in the United States by Square D. This supply is DIN rail-mountable and has a form factor similar to that of the island modules.

If you have room in your cabinet and your 24 VDC power requirements are greater than 72 W, summable power supply options such as Schneider's Premium TSX SUP 1011 (26 W), TSX SUP 1021 (53 W), TSX SUP 1051 (120 W), or TSX SUP 1101 (240 W) can be considered. These modules are also available from Telemecanique and, in the United States, from Square D.

---

## Module Specifications

### Specifications Detail

The general specifications for the STB NIP 2212, which is the Ethernet network interface module (NIM) for an Advantys STB island bus, appear in the following table:

General Specifications		
dimensions	width	40.5 mm (1.594 in)
	height	130 mm (4.941 in)
	depth	70 mm (2.756 in)
interface and connectors	to the Ethernet LAN	RJ-45 female connector CAT5 STP/UTP twisted-pair, electrical cable(s)
	RS-232 (See <i>Physical Description</i> , p. 33) port for device running the Advantys configuration software or an HMI panel (See <i>The HMI Blocks in the Island Data Image</i> , p. 172)	eight-pin connector HE-13
	to the external 24 VDC power supply	two-pin connector (See <i>The Power Supply Interface</i> , p. 35)
built-in power supply	input voltage	24 VDC nominal
	input power range	19.2 ... 30 VDC
	internal current supply	400 mA @ 24 VDC, consumptive
	output voltage to the island bus	5 VDC nominal
		2% variation due to temperature drift, intolerance, or line regulation
		1% load regulation
		$\leq 50 \text{ m}\Omega$ output impedance up to 100 kHz
output current rating	1.2 A @ 5 VDC	
isolation	no internal isolation <i>Isolation must be provided by an external 24 VDC source power supply, which must be SELV-rated.</i>	

<b>General Specifications</b>		
addressable modules supported (See <i>Addressable Modules, p. 46</i> )	per segment	16 maximum
	per island	32 maximum
segments supported	primary (required)	one
	extension (optional)	six maximum
standards	Ethernet conformance	IEEE 802.3
	Hypertext Transfer Protocol (HTTP)	Port 80 SAP
	Simple Network Management Protocol (SNMP)	Port 161 SAP
	Modbus over TCP/IP	Port 502 SAP
	MTBF	200,000 hours GB (ground benign)
	electromagnetic compatibility (EMC)	IEC 1131



---

# Configuring the Island Bus

# 3

---

## At a Glance

### Introduction

The information in this chapter describes the auto-addressing and auto-configuration processes. An Advantys STB system has an auto-configuration capability in which the current, actual assembly of I/O modules on the island bus is read every time that the island bus is either powered up or reset. This configuration data is saved to Flash memory automatically.

The removable memory card is discussed in this chapter. The card is an Advantys STB option for storing configuration data offline. Factory default settings can be restored to the island bus I/O modules and the CFG port by engaging the RST button.

The NIM is the physical and logical location of all island bus configuration data and functionality.

### What's in this Chapter?

This chapter contains the following topics:

Topic	Page
Auto-Addressing	46
Auto-Configuration	49
Installing the STB XMP 4440 Optional Removable Memory Card	50
Using the STB XMP 4440 Optional Removable Memory Card to Configure the Island Bus	53
The RST Button	55
RST Functionality	56

## Auto-Addressing

---

### Introduction

Each time that the island is powered up or reset, the NIM automatically assigns a unique island bus address to each module on the island that will engage in data exchange. All Advantys STB I/O modules and preferred devices engage in data exchange and require island bus addresses.

---

### About the Island Bus Address

An island bus address is a unique integer value in the range 0 through 127 that identifies the physical location of each addressable module on the island. Addresses 0, 124, 125 and 126 are reserved. Address 127 is always the NIM's address. Addresses 1 through 123 are available for I/O modules and other island devices.

During initialization, the NIM detects the order in which modules are installed and addresses them sequentially from left to right, starting with the first addressable module after the NIM. No user action is required to address these modules.

---

### Addressable Modules

The following module types require island bus addresses:

- Advantys STB I/O modules
- preferred devices
- standard CANopen devices

Because they do not exchange data on the island bus, the following are not addressed:

- bus extension modules
  - PDMs such as the STB PDT 3100 and STB PDT 2100
  - empty bases
  - termination plate
-

**An Example**

For example, if you have an island bus with eight I/O modules:

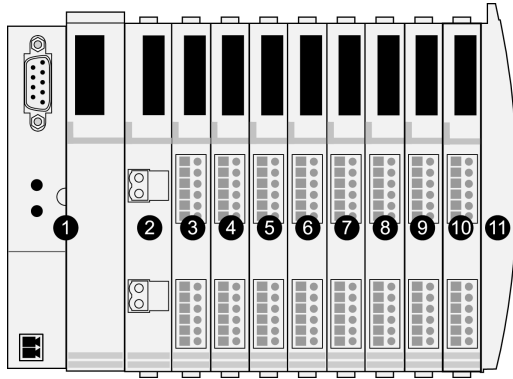

- 1 NIM
- 2 STB PDT 3100 24 VDC power distribution module
- 3 STB DDI 3230 24 VDC two-channel digital input module
- 4 STB DDO 3200 24 VDC two-channel digital output module
- 5 STB DDI 3420 24 VDC four-channel digital input module
- 6 STB DDO 3410 24 VDC four-channel digital output module
- 7 STB DDI 3610 24 VDC six-channel digital input module
- 8 STB DDO 3600 24 VDC six-channel digital output module
- 9 STB AVI 1270 +/-10 VDC two-channel analog input module
- 10 STB AVO 1250 +/-10 VDC two-channel analog output module
- 11 STB XMP 1100 island bus termination plate

The NIM would auto-address it as follows. Note that the PDM and the termination plate do not consume island bus addresses:

Module	Physical Location	Island Bus Address
NIM	1	127
STB PDT 3100 PDM	2	not addressed—does not exchange data
STB DDI 3230 input	3	1
STB DDO 3200 output	4	2
STB DDI 3420 input	5	3
STB DDO 3410 output	6	4
STB DDI 3610 input	7	5
STB DDO 3600 output	8	6
STB AVI 1270 input	9	7
STB AVO 1250 output	10	8

**Associating the  
Module Type  
with the Island  
Bus Location**

As a result of the configuration process, the NIM automatically identifies physical locations on the island bus with specific I/O module types. This feature enables you to hot swap a failed module with a new module of the same type.

---



## Auto-Configuration

---

### Introduction

All Advantys STB I/O modules are shipped with a set of predefined parameters that allow an island to be operational as soon as it is initialized. This ability of island modules to operate with default parameters is known as auto-configuration. Once an island bus has been installed, assembled, and successfully parameterized and configured for your fieldbus network, you can begin using it as a node on that network.

**Note:** A valid island configuration does not require the intervention of the optional Advantys configuration software.

---

### About Auto-Configuration

Auto-configuration occurs when:

- You power up an island for the first time.
- You push the RST button (See *The RST Button*, p. 55).

As part of the auto-configuration process, the NIM checks each module and confirms that it has been properly connected to the island bus. The NIM stores the default operating parameters for each module in Flash memory.

---

### Customizing a Configuration

You can customize the operating parameters of the I/O modules, create reflex actions, add preferred modules and/or CANopen standard devices to the island bus, and customize other island capabilities.

---

## Installing the STB XMP 4440 Optional Removable Memory Card

---

### Introduction

The STB XMP 4440 removable memory card is a 32-kbyte subscriber identification module (SIM) that lets you store (See *Saving Configuration Data*, p. 164), distribute, and reuse custom island bus configurations. If the island is in unprotected (edit) mode (See *Protection Feature*, p. 165) and a removable memory card containing a valid island bus configuration is inserted in the NIM, the configuration data on the card overwrites the configuration data in Flash memory, and is adopted when the island starts up. If the island is in protected mode, the island ignores the presence of a removable memory card.

The removable memory card is an optional Advantys STB feature.

**Note:** Network configuration data, such as the fieldbus baud setting cannot be saved to the card.

### Physical Description

The card measures 25.1 mm (0.99 in) wide x 15 mm (0.59 in) high x 0.76 mm (0.30 in) thick. It is shipped as a punch-out on a credit-card-sized plastic card, which measures 85.6 mm (3.37 in) wide x 53.98 mm (2.13 in) high.

**Note:** Keep the card free of contaminants and dirt.

	<p><b>CAUTION</b></p> <p><b>LOSS OF CONFIGURATION—MEMORY CARD DAMAGE OR CONTAMINATION</b></p> <p>The card's performance can be degraded by dirt or grease on its circuitry. Contamination or damage may create an invalid configuration.</p> <ul style="list-style-type: none"> <li>● Use care when handling the card.</li> <li>● Inspect for contamination, physical damage, and scratches before installing the card in the NIM drawer.</li> <li>● If the card does get dirty, clean it with a soft dry cloth.</li> </ul> <p><b>Failure to follow this precaution can result in injury or equipment damage.</b></p>
--	---

## Installing the Card

Use the following procedure to install the card:

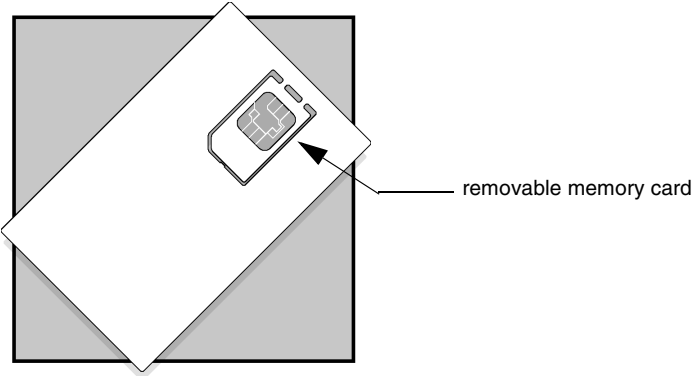
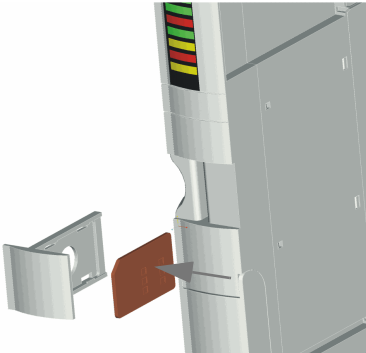
Step	Action
1	<p>Punch out the removable memory card from the plastic card on which it is shipped.</p>  <p>Make sure that the edges of the card are smooth after you punch it out.</p>
2	<p>Open the card drawer on the front of the NIM. If it makes it easier for you to work, you may pull the drawer completely out from the NIM housing.</p>
3	<p>Align the chamfered edge (the 45° corner) of the removable memory card with the one in the mounting slot in the card drawer. Hold the card so that the chamfer is in the upper left corner.</p> 
4	<p>Seat the card in the mounting slot, applying slight pressure to the card until it snaps into place. The back edge of the card must be flush with the back of the drawer.</p>
5	<p>Close the drawer.</p>

**Removing the Card**

Use the following procedure to remove the card from the card drawer. As a handling precaution, avoid touching the circuitry on the removable memory card during its removal.

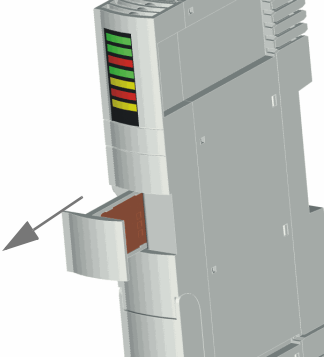
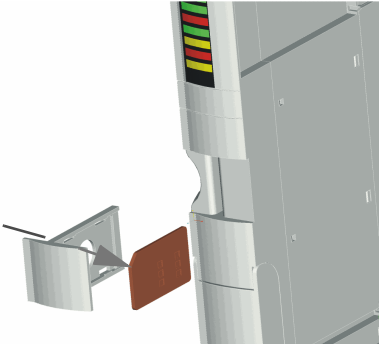
Step	Action
1	Open the card drawer. 
2	Push the removable memory card out of the drawer through the round opening at the back. Use a soft but firm object like a pencil eraser. 

## Using the STB XMP 4440 Optional Removable Memory Card to Configure the Island Bus

---

### Introduction

A removable memory card is read when an island is powered on. If the configuration data on the card is valid, the current configuration data in Flash memory is overwritten.

A removable memory card can be *active* only if an island is in *edit* mode. If an island is in protected mode (See *Protecting Configuration Data*, p. 165), the card and its data are ignored.

---

### Configuration Scenarios

The following discussion describes several island configuration scenarios that use the removable memory card. The scenarios assume that a removable memory card is already installed in the NIM:

- initial island bus configuration
- replace the current configuration data in Flash memory in order to:
  - apply custom configuration data to your island
  - temporarily implement an alternative configuration; for example, to replace an island configuration used daily with one used to fulfill a special order
- copying configuration data from one NIM to another, including from a failed NIM to its replacement; the NIMs must run the same fieldbus protocol
- configuring multiple islands with the same configuration data

**Note:** Whereas writing configuration data *from* the removable memory card to the NIM does not require use of the optional Advantys configuration software, you must use this software to save (write) configuration data *to* the removable memory card in the first place.

### Edit Mode

Your island bus must be in edit mode to be configured. In edit mode, the island bus can be written to as well as monitored.

Edit mode is the default operational mode for the Advantys STB island:

- A new island is in edit mode.
  - Edit mode is the default mode for a configuration downloaded from the Advantys configuration software to the configuration memory area in the NIM.
-

**Initial Configuration and Reconfiguration Scenarios**

Use the following procedure to set up an island bus with configuration data that was previously saved (See *Saving Configuration Data*, p. 164) to a removable memory card. You can use this procedure to configure a new island or to overwrite an existing configuration. *Note: Using this procedure will destroy your existing configuration data.*

Step	Action	Result
1	Install (See <i>Installing the STB XMP 4440 Optional Removable Memory Card</i> , p. 50) the removable memory card in its drawer in the NIM.	
2	Power on the new island bus.	<p>The configuration data on the card is checked. If the data is valid, it is written to Flash memory. The system restarts automatically, and the island is configured with this data. If the configuration data is invalid, it is not used and the island bus will stop.</p> <p>If the configuration data was unprotected, the island bus remains in edit mode. If the configuration data on the card was password-protected (See <i>Protecting Configuration Data</i>, p. 165), your island bus enters protected mode at the end of the configuration process.</p> <p><b>Note:</b> If you are using this procedure to reconfigure an island bus and your island is in protected mode, you can use the configuration software to change the island's operational mode to edit.</p>

**Configuring Multiple Island Buses with the Same Data**

You can use a removable memory card to make a copy of your configuration data; then use the card to configure multiple island buses. This capability is particularly advantageous in a distributed manufacturing environment or for an OEM (original equipment manufacturer).

**Note:** The island buses may be either new or previously configured, but the NIMs must all run the same fieldbus protocol.

## The RST Button

### Summary

The RST function is basically a Flash memory overwriting operation. This means that RST is functional only after the island has been successfully configured at least once. All RST functionality is performed with the RST button, which is enabled only in edit mode.

### Physical Description

The RST button is located immediately above the CFG port (See *Physical Description*, p. 33), and behind the same hinged cover:

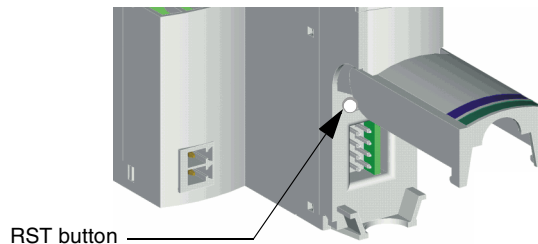

Holding down the RST button for two seconds or longer causes Flash memory to be overwritten, resulting in a new configuration for the island.

	<b>CAUTION</b>
	<p><b>UNINTENDED EQUIPMENT OPERATION/CONFIGURATION OVERWRITTEN—RST BUTTON</b></p> <p>Do not attempt to restart the island by pushing the RST button. Pushing the RST button will cause the island bus to reconfigure itself with factory default operating parameters.</p> <p><b>Failure to follow this precaution can result in injury or equipment damage.</b></p>

### Engaging the RST Button

To engage the RST button, it is recommended that you use a small screwdriver with a flat blade no wider than 2.5 mm (.10 in). Do not use a sharp object that might damage the RST button, nor a soft item like a pencil that might break off and jam the button.

## RST Functionality

---

### Introduction

The RST function allows you to reconfigure the operating parameters and values of an island by overwriting the current configuration in Flash memory. RST functionality affects the configuration values associated with the I/O modules on the island, the operational mode of the island, and the CFG port parameters.

The RST function is performed by holding down the RST button (See *The RST Button*, p. 55) for at least two seconds. The RST button is enabled only in edit mode. In protected mode (See *Protecting Configuration Data*, p. 165), the RST button is disabled; pressing it has no effect.

**Note:** Network settings, such as the fieldbus baud and the fieldbus node ID, remain unaffected.

	<b>CAUTION</b>
	<b>UNINTENDED EQUIPMENT OPERATION/CONFIGURATION DATA OVERWRITTEN—RST BUTTON</b> Do not attempt to restart the island by pushing the RST button. Pushing the RST button (See <i>The RST Button</i> , p. 55) causes the island bus to reconfigure itself with factory default operating parameters. <b>Failure to follow this precaution can result in injury or equipment damage.</b>

### RST Configuration Scenarios

The following scenarios describe some of the ways that you can use the RST function to configure your island:

- Restore factory-default parameters and values to an island, including to the I/O modules and the CFG port (See *Port Parameters*, p. 33).
- Add a new I/O module to a previously auto-configured (See *Auto-Configuration*, p. 49) island.

If a new I/O module is added to the island, pressing the RST button will force the auto-configuration process. The updated island configuration data is automatically written to Flash memory.

---



### Overwriting Flash Memory with Factory Default Values

The following procedure describes how to use the RST function to write default configuration data to Flash memory. Follow this procedure if you want to restore default settings to an island. This is also the procedure to use to update the configuration data in Flash memory after you add an I/O module to a previously auto-configured island bus. *Because this procedure will overwrite the configuration data, you may want to save your existing island configuration data to a removable memory card before pushing the RST button.*

Step	Action
1	If you have a removable memory card installed, remove it (See <i>Removing the Card</i> , p. 52).
2	Ensure that your island is in edit mode.
3	Hold the RST button (See <i>The RST Button</i> , p. 55) down for at least two seconds.

### The Role of the NIM in this Process

The NIM reconfigures the island bus with default parameters as follows:

Stage	Description
1	The NIM auto-addresses (See <i>Auto-Addressing</i> , p. 46) the I/O modules on the island and derives their factory-default configuration values.
2	The NIM overwrites the current configuration in Flash memory with configuration data that uses the factory-default values for the I/O modules.
3	It resets the communication parameters on its CFG port to their factory-default values (See <i>Port Parameters</i> , p. 33).
4	It re-initializes the island bus and brings it into operational mode.



---

# IP Parameters



# 4

---

## At a Glance

### Introduction

The information in this chapter describes how IP parameters are assigned to the STB NIP 2212.

### What's in this Chapter?

This chapter contains the following topics:

Topic	Page
How the STB NIP 2212 Obtains IP Parameters	60
The IP Address Assignment Process	63

## How the STB NIP 2212 Obtains IP Parameters

---

### Summary

As a node on a TCP/IP network, the STB NIP 2212 requires a valid 32-bit IP address. The IP address can be:

- the MAC-based default IP address
- assigned by an Internet server
- customer-configured using the STB NIP 2212 web pages (See *About the Embedded Web Server*, p. 67)

**Note:** Refer to the IP parameters flow chart (See *The IP Address Assignment Process*, p. 63) for information about how the STB NIP 2212 prioritizes IP address assignment options.

---

### Deriving an IP Address from a Media Access Control (MAC) Address

The 32-bit default IP address for the STB NIP 2212 is composed of the last four octets of its 48-bit Media Access Control (MAC) address. The MAC address, or Institute of Electrical and Electronics Engineers, Inc. (IEEE) global address is assigned at the factory. The MAC address for an STB NIP 2212 is located on the front bezel under the Ethernet port (See *External Features of the STB NIP 2212, p. 24*).

A MAC address is stored in hexadecimal format. The numbers in the MAC address must be converted from hexadecimal to decimal notation to derive the *default IP address*. Use the following steps:

Step	Action
1	A MAC address comprises six pairs of hex values, e.g., 00 00 54 10 01 02. Ignore the first two pairs: 00 00.
2	Identify a pair, e.g., 54.
3	Multiply the first number, 5 by 16. ( $5 \times 16 = 80$ ).
4	Add the second number, 4 ( $80 + 4 = 84$ ).

**Note:** There are many resources for converting hex numbers to decimal numbers. We recommend using the Windows calculator in scientific mode.

**Note:** If you set the lower rotary switch to either INTERNAL position (See *Rotary Switches, p. 28*) and no IP parameters have been assigned from the STB NIP 2212 web site, the STB NIP 2212 is configured with its derived default address when it is powered on.

**MAC-Based  
IP Address  
Example**

In the following example, the hex pairs in the example IEEE global address (MAC address) **54.10.2D.11** are converted into a decimal number in the derived IP address. The derived IP address is **84.16.45.17**, so this becomes the default IP address for the example STB NIP 2212:

**Hex Pair Decimal Conversion**

$$5 \times 16 = 80 + 4 = 84$$

$$10 \\ 1 \times 16 = 16 + 0 = 16$$

$$2D \\ 2 \times 16 = 32 + 13 = 45 \\ D = 13 \text{ in hex}$$

$$11 \\ 1 \times 16 = 16 + 1 = 17$$

---

**Server-Assigned  
IP Addresses**

A server-assigned IP address may be obtained from either a BootP or a DHCP server. A BootP server must be invoked using either BOOTP position on the lower rotary switch (See *Physical Description, p. 28*). A DHCP-served IP address is associated with a role name.

---

**Role Name**

A role name is a combination of the Ethernet NIM part number STBNIP2212 and a numeric value, e.g., *STBNIP2212\_123*.

A role name may be assigned in one of two ways:

- using the numeric settings (00 to 159) on the rotary switches (See *Physical Description, p. 28*)
  - setting the lower rotary switch to an INTERNAL position, powering on the STB NIP 2212, and completing the Role Name web page (See *Sample Role Name Web Page, p. 83*).
- 

**Customer-  
Configured  
IP Address**

If your STB NIP 2212 does not have a role name, you can configure an IP address directly on the Configured IP web page (See *Sample Configured IP Web Page, p. 73*). Set the lower rotary switch to an INTERNAL position, power on the STB NIP 2212, and complete the web page.

---

## The IP Address Assignment Process

### Determining the IP Address

As shown in the following flow chart, the STB NIP 2212 performs a sequence of checks to determine an IP address:

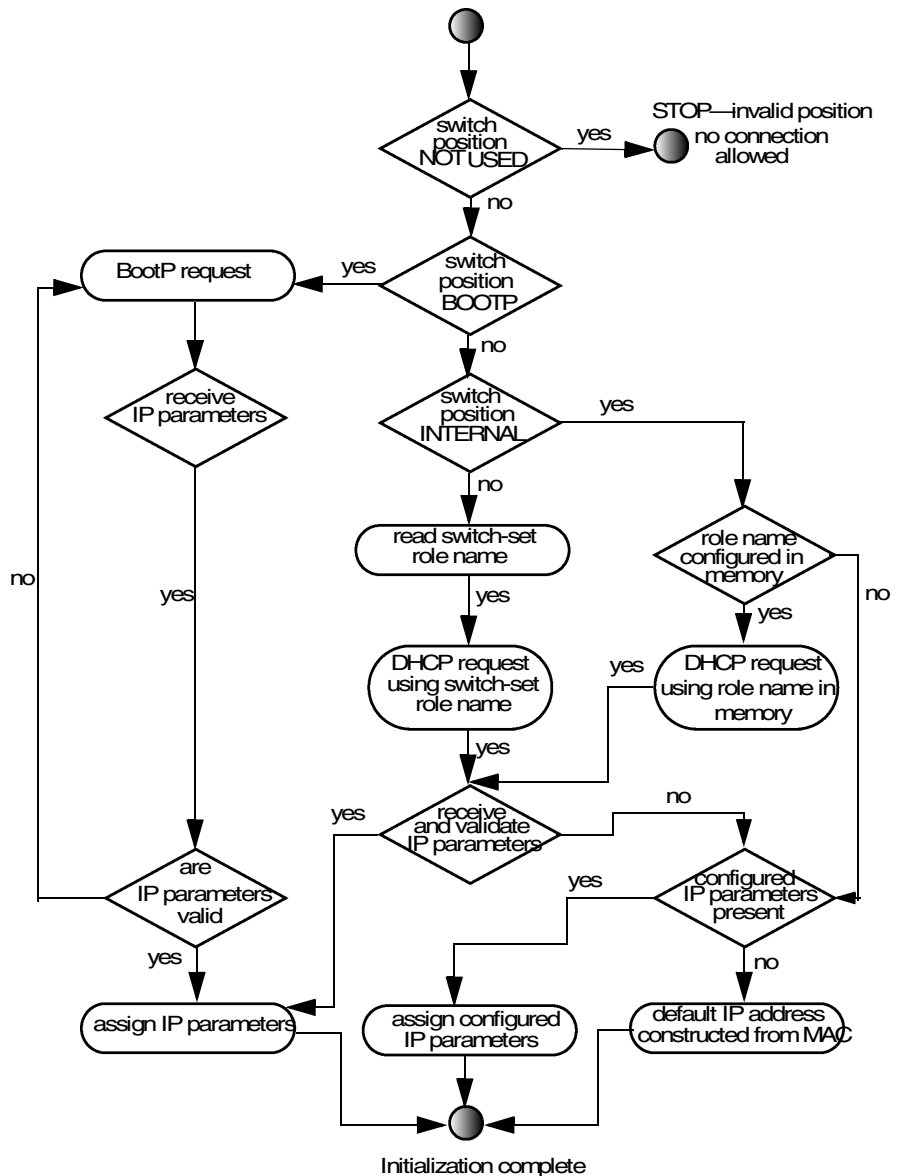

**IP Address  
Software  
Priorities**

The IP addressing methods for the STB NIP 2212 are prioritized in the order listed in the following table. Note: The lower rotary switch must be set to either of the two INTERNAL positions (See *Rotary Switches*, p. 28):

Priority	IP Address Method
1	role name
2	configured IP parameters (set up on the Configured IP web page (See <i>Sample Configured IP Web Page</i> , p. 73))
3	MAC-based default IP address (See <i>Deriving an IP Address from a Media Access Control (MAC) Address</i> , p. 61)

---

**Frame Format  
Priorities**

The STB NIP 2212 supports communications in the Ethernet II and 802.3 frame formats. Ethernet II is the default.

When communicating with a BootP server, the STB NIP 2212 first makes three requests using the Ethernet II frame format; then it makes three requests using the 802.3 frame format. The interval between each request is one second.

When communicating with a DHCP server, the STB NIP 2212 makes eight requests using the Ethernet II frame format; then it makes eight requests using the 802.3 frame format.

---



---

# STB NIP 2212 Web Server



---

## At a Glance

### Introduction

The STB NIP 2212 includes an embedded web server that is described in this chapter.

### What's in this Chapter?

This chapter contains the following sections:

Section	Topic	Page
5.1	Introduction to the Embedded Web Server	66
5.2	Web Server Configuration Options	71
5.3	Web Server Security	86
5.4	Web Server Diagnostic Options	92
5.5	SNMP Services	103

---

## 5.1 Introduction to the Embedded Web Server

---

### At a Glance

---

#### Introduction

This section introduces the STB NIP 2212 embedded web server.

---

#### What's in this Section?

This section contains the following topics:

Topic	Page
About the Embedded Web Server	67
Properties Web Page	70

---

## About the Embedded Web Server

---

<b>Introduction</b>	The STB NIP 2212 includes a Hypertext Transfer Protocol (HTTP) based embedded web server. Via a web browser (See <i>Browser Requirements</i> , p. 67), configuration and diagnostic data about the island node can be viewed and selectively edited.
<b>Initialization of the HTTP Server</b>	At the end of the IP parameterization process (See <i>Determining the IP Address</i> , p. 63), the STB NIP 2212 is initialized as an HTTP server, and its web pages are available to view and/or edit.
<b>Browser Requirements</b>	Either the Netscape Navigator browser, version 4.0 or greater, or the Internet Explorer browser, version 4.0 or greater, must be used with the STB NIP 2212 web pages.
<b>Security</b>	The STB NIP 2212 web site has three layers of security: <ul style="list-style-type: none"><li>• The initial security is provided by the default HTTP password. You should replace this password with your own web access password (See <i>Web Access Password Protection</i>, p. 87).</li><li>• Knowledge of your web access password allows read-only access to your STB NIP 2212 web site.</li><li>• Knowledge of the configuration password (See <i>Configuration Password Protection</i>, p. 90) allows read/write access to your STB NIP 2212 web site.</li></ul>
<b>Web Page Help</b>	Page-level help is available for every STB NIP 2212 web page. To display the help text for a page, click on the word <b>Help</b> . It is located at the top of the web page and to the right of the STB NIP 2212 banner.

---

## Accessing the STB NIP 2212 Web Site

Use the following steps to access the STB NIP 2212 web site:

Step	Action	Result
1	Go to your url: <b>http://configured IP address</b>	The STB NIP 2212 home page is displayed.
2	Enter your language preference. English is the default language. <ul style="list-style-type: none"> <li>● If your language preference is English, click on the <b>Enter</b> button.</li> <li>● To select a different language, click on its name, e.g., Deutsche. Then click on the <b>Enter</b> button.</li> </ul>	The web access password dialog box is displayed.
3	Type the user name and the web access password for your STB NIP 2212 site. Then click on the <b>OK</b> button to proceed. <b>Note:</b> The default user name and password are <code>USER</code> . Both are case-sensitive. They should be changed (See <i>Web Access Password Protection</i> , p. 87) for your STB NIP 2212 web site.	The STB NIP 2212 Properties (See <i>Properties Web Page</i> , p. 70) page is displayed.
4	To navigate to a different web page, click on its tab. For example, for information about how to contact the STB NIP 2212 product support team, click on the <b>Support</b> tab.	The Support web page (See <i>Product Support Web Page</i> , p. 69) is displayed.

**Product Support  
Web Page**

Information about how to contact Schneider Electric about your STB NIP 2212 product is available from the Support web page. A sample Support page appears in the following figure:

**Telemecanique** **STB NIP 2212 - STANDARD**

Role Name: No Rolename IP: 139.158.13.113 Home Help

Properties | Configuration | **Support** | Security | Diagnostics

**Merlin Gerin**  
**Modicon**  
**Square D**  
**Telemecanique**

### Contacting Schneider Electric

**Technical Information**  
[Click here](#) to go to the Schneider Electric Automation web site.

**Contact Us**  
[Click here](#) to contact Schneider Electric in your country.

---

Schneider Electric Inc., ©1998-2003

## Properties Web Page

### Introduction

The Properties web page displays STB NIP 2212 statistics, such as the version of the kernel and the executive, as well as the communications protocols for which the STB NIP 2212 is configured.

### Sample Properties Web Page

The Properties page is displayed automatically after the HTTP server authenticates the user name and web access password. A sample Properties page is shown in the following figure:

Kernel Version:	0.7
Exec Version:	0.22
Web Site:	1.0
SNMP:	2.0
HTTP:	1.1
DHCP:	1.0
BootP:	1.0
Modbus Serial:	1.0
Modbus TCP:	1.0

Schneider Electric Inc., ©1998-2003

- 1 STB NIP 2212 banner. The role name (if configured) and the IP address in current use display in the web banner.
- 2 Click on the word Home to return to the STB NIP 2212 home page.
- 3 Click on the word Help to display the help text for this web page.
- 4 The network activity icon indicates which communications protocols are active. The top light represents HTTP, the middle light Modbus, and the bottom light FTP. If a protocol is active, the light representing it is lit. For more information, drag the mouse over the light.
- 5 Navigation tabs.
- 6 Schneider Electric copyright information.

---

## 5.2 Web Server Configuration Options

---

### At a Glance

---

**Introduction** The information in this section describes the configuration options supported by the STB NIP 2212 embedded web server.

---

**What's in this Section?** This section contains the following topics:

Topic	Page
Configuration Web Page	72
Configuring an IP Address for the STB NIP 2212	73
Configuring Master Controllers	78
Master Configurator Web Page	80
Configuring a Role Name	83

---

## Configuration Web Page

### Introduction

The web-based resources that are available for configuring the STB NIP 2212 are listed as options on the Configuration menu. The specific web page for each feature is linked to a menu option.

### Web-Based Configuration Options

The Configuration menu appears in the following figure:

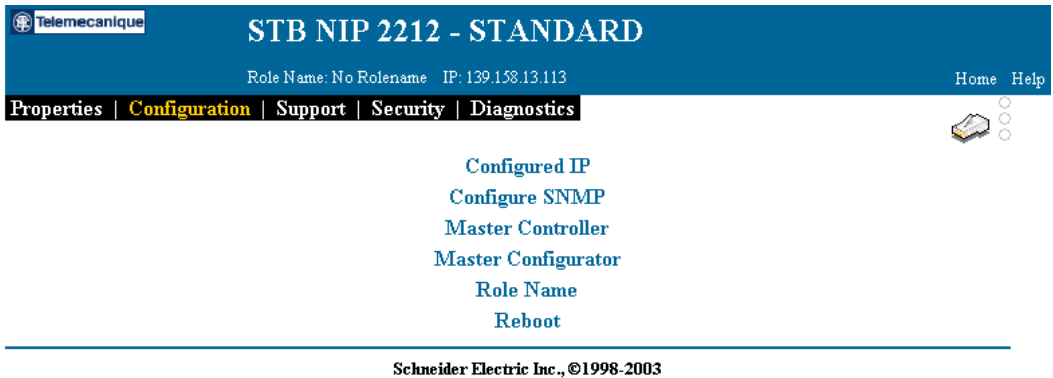

### Accessing the Configuration Menu

Use step 1 in the following procedure to access the Configuration menu. Then use step 2 to navigate to the specific web page for the configuration option:

Step	Action	Result
1	Click on the Configuration tab.	The Configuration menu is displayed.
2	Click on the option that you want to use, e.g., Master Configurator (See <i>Master Configurator Web Page, p. 80</i> ).	The web page for the configuration option that you selected is displayed.



# Configuring an IP Address for the STB NIP 2212

## Introduction

To communicate as a node on the Internet, the fieldbus (Ethernet) port on the STB NIP 2212 must be configured with a valid IP address. The IP address must be unique on the Ethernet LAN on which the STB NIP 2212 resides. One of the available IP address assignment methods (See *How the STB NIP 2212 Obtains IP Parameters, p. 60*) is to configure an IP address yourself. A customer configured IP address is set up on the Configured IP web page.

## Sample Configured IP Web Page

A sample Configured IP web page appears in the following figure:

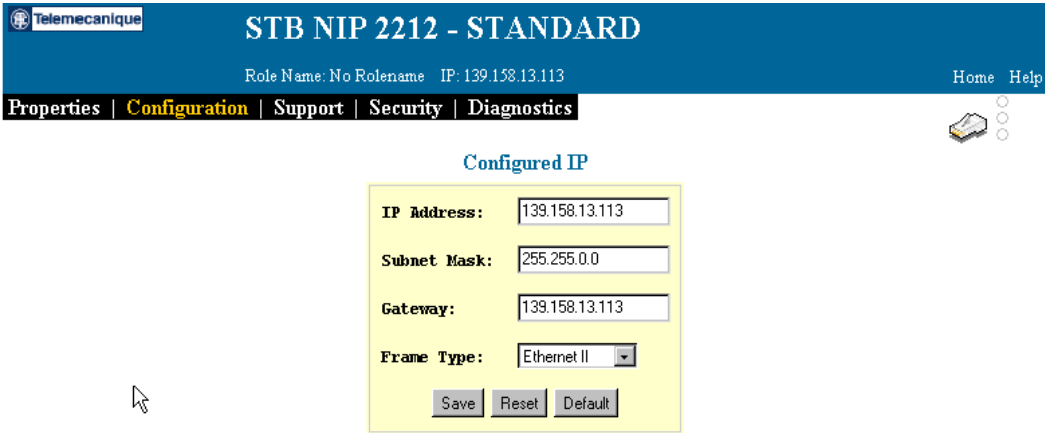

**IP Parameters**

The IP address for the STB NIP 2212 has the four parameters, which are described in the following table:

Parameter	Description
IP address	Unique 32-bit address assigned to every node on the Internet.
subnet mask	The subnet mask is 32 bits assigned with the IP address of a host. The contiguous 1's of the mask are used to separate the network portion from the host portion of the address. When the subnet mask is applied to the source and destination addresses, it determines if the target host is on the local subnet or on a remote network.
gateway	The default gateway, typically a router, is where the host sends frames that are bound for remote networks after the subnet mask compare.
frame type	Data format used by a protocol. For example, the STB NIP 2212 can use either the Ethernet II or the IEEE 802.3 frame format. Ethernet II is the default.
<b>Note:</b> The IP address for the STB NIP 2212 is written in dotted decimal format.	

**Using the Command Buttons**

The following table describes how to use the command buttons on the Configured IP web page:

To ...	Click on ...
Display the IP address stored in Flash memory	<b>Reset</b>
Display the MAC-based, derived default IP address.	<b>Default</b>
Save the IP address displayed on the Configured IP web page.	<b>Save</b>
Configure the STB NIP 2212 with the IP address displayed on the Configured IP web page.	<b>Reboot</b>

## Assigning a Configured IP Address to the STB NIP 2212

Use the following procedure to configure an IP address for the STB NIP 2212.  
*Note: Your STB NIP 2212 cannot have a role name.*

Step	Action	Comment
1	Set the lower rotary switch to an INTERNAL position (See <i>Physical Description</i> , p. 28), and power cycle the STB NIP 2212.	
2	If your STB NIP 2212, has a role name, you must remove it using the Role Name web page (See <i>Configuring a Role Name</i> , p. 83).	If no role name is assigned, skip step 2.
3	Open the STB NIP 2212 web site.	
4	Click on the Configuration tab to display the Configuration menu.	
5	Select the Configured IP option.	
6	In the IP address field, type the IP address that you want to use in dotted decimal format.	
7	Click on the <b>Save</b> button to save the address to Flash memory and in RAM.	If the address is valid, it will appear in the banner at the top of each STB NIP 2212 web page. <b>Note:</b> The LAN ST LED (See <i>Ethernet Communications LEDs</i> , p. 31) on the NIM blinks four times if the IP address is a duplicate.
8	Click on the Configuration tab to return to the Configuration menu.	
9	Select the Reboot option (See <i>About the Reboot Option</i> , p. 77).	
10	At the Reboot now? prompt, click on the <b>OK</b> button.	
11	Click on the <b>OK</b> button at the confirmation prompt, "Are you sure?"	Your STB NIP 2212 restarts. The IP address that you set up on the web is the active IP address for the island.

### Restoring Default Parameters from the Web

Use the following procedure to reconfigure the STB NIP 2212 with its default IP parameters (See *Deriving an IP Address from a Media Access Control (MAC) Address*, p. 61) from the web. *Note: Your STB NIP 2212 cannot have a role name.*

Step	Action	Comment
1	Open the STB NIP 2212 web site.	
2	Click on the Configuration tab to display the Configuration menu.	
3	Select the Configured IP option.	The Configured IP web page (See <i>Sample Configured IP Web Page</i> , p. 73) opens.
4	Click on the <b>Default</b> button.	The IP address parameters are restored to their default values. The address is based on the 48-bit MAC address that was programmed into the STB NIP 2212 when it was manufactured.
5	Click on the <b>Save</b> button to save the address to Flash memory and in RAM.	<b>Note:</b> The LAN ST LED (See <i>Ethernet Communications LEDs</i> , p. 31) on the NIM blinks six times if the STB NIP 2212 default address is in use. If the address is a duplicate, the LAN ST LED blinks four times.
6	Click on the Configuration tab to return to the Configuration menu.	
7	Select the Reboot option (See <i>About the Reboot Option</i> , p. 77).	
8	At the Reboot now? prompt, click on the <b>OK</b> button.	
9	Click on the <b>OK</b> button at the confirmation prompt, "Are you sure?"	

## About the Reboot Option

The reboot operation will configure the STB NIP 2212 with IP parameters assigned on the web. Information about the reboot operation appears in the following figure:

The screenshot shows the web interface for the STB NIP 2212 - STANDARD. The header includes the Telemecanique logo and the title "STB NIP 2212 - STANDARD". Below the title, it displays "Role Name: No Rolename" and "IP: 139.158.13.113". Navigation links for "Home" and "Help" are present. A menu bar contains "Properties", "Configuration", "Support", "Security", and "Diagnostics". A mouse cursor is positioned over the "Reboot" option in the menu. A yellow dialog box is displayed with the text: "Reboot causes the STBNIP2212 NIM to become non-operational temporarily during the reboot process. Reboot does not read the rotary switch settings . It assumes that the settings that were applied at initial power-up are still valid and applies these settings to the STBNIP2212 Network Interface Module . If the rotary switches were set to look at an internal IP or role name setting , reboot will apply the most recent internal settings to the NIM." Below the text is a button labeled "Reboot now." and an "Ok" button.

**Reboot**

Reboot causes the STBNIP2212 NIM to become non-operational temporarily during the reboot process. Reboot does not read the rotary switch settings . It assumes that the settings that were applied at initial power-up are still valid and applies these settings to the STBNIP2212 Network Interface Module . If the rotary switches were set to look at an internal IP or role name setting , reboot will apply the most recent internal settings to the NIM.

**Reboot now.**

Ok

Schneider Electric Inc., ©1998-2003

## Configuring Master Controllers

### Introduction

Any controller on the Ethernet network has the potential to become the master of an island on that network. Mastery can be obtained on a first-come/first-serve basis. The STB NIP 2212 allows you to pre-assign mastery to as many as three specific controllers on the network. If one of these assigned controllers is connected, it will take mastery over any unassigned controllers, even if an unassigned controller has connected to the island first. To assign one or more master controllers, use the Master Controller web page.

### Understanding Processing Mastery

A controller that has mastery over an island has the ability to write to the island's output process image and to change operating parameters on the island nodes.. Typically, the first controller to request write access is granted mastery. If another master attempts to write to the island while the first controller has mastery, the NIM sends an error message and access is denied. If a master controller has been configured on the Master Controller web page (See *Sample Master Controller Web Page, p. 79*), a write request from it will pre-empt processing mastery from any other device during its reservation time.

### Fields on the Master Controller Web Page

To pre-assign one or more (up to three) master controllers for the STB NIP 2212, identify them by their IP addresses:

Field Name	Description
Master x ID*	The unique IP address (See <i>How the STB NIP 2212 Obtains IP Parameters, p. 60</i> ) for a master controller.
reservation time	The amount of time in ms allocated to a master controller for writing to the STB NIP 2212. Other controllers attempting to write to the STB NIP 2212 while the master is connected will receive an error message. The default reservation time is 60,000 (1 min). Each time the master writes to the NIM, the reservation time is reset to 60,000.
holdup time	The amount of time in ms that output modules will hold their current state without an update by a Modbus write command (See <i>List of Supported Commands, p. 134</i> ). When the module hold-up time out expires, the outputs will be driven to their defined fallback states (See <i>Island Fallback Scenarios, p. 162</i> ). Note: The holdup time must be defined via the Master Controller web page. Holdup time out parameters and values are stored in nonvolatile Flash memory.
* If you do not enter an IP address, then write access to the NIM will be obtained by the first master that writes to it.	

**Setting Up Master Controllers for the Island**

Use the following procedure to configure a master controller for the STB NIP 2212:

Step	Action
1	Click on the Configuration tab to display the Configuration menu.
2	Select the Master Controller option.
3	Type the IP address for each master controller (up to three) that you want to set up.
4	Type a value for the reservation time (0 ... 120000 ms). This is the amount of time allocated to any master controller. The default setting is 60000 ms (1 min).
5	Type a value in ms for the holdup time. The default setting is 1000 ms. (1 sec). The valid values are: <ul style="list-style-type: none"> <li>• values in the range 300 ... 120,000 ms.</li> <li>• a value of 0 ms signifying indefinite hold up time</li> </ul> <b>Note:</b> You must enter the holdup value via the web page.
6	Click on the <b>Save</b> button to store information about the master controller in the STB NIP 2212's Flash memory and in RAM.

**Sample Master Controller Web Page**

A sample Master Controller web page is shown in the following figure:

The screenshot shows the web interface for the STB NIP 2212 - STANDARD. At the top, there is a blue header with the Telemecanique logo on the left, the title "STB NIP 2212 - STANDARD" in the center, and "Role Name: No Rolename IP: 139.158.13.113" below it. On the right side of the header are "Home" and "Help" links. Below the header is a navigation bar with tabs: "Properties", "Configuration" (highlighted in yellow), "Support", "Security", and "Diagnostics". To the right of the navigation bar is a small icon of a server rack with three circles above it. The main content area is titled "Master Controller" and contains a yellow-bordered form with the following fields:
 

- Master1 IP:
- Master2 IP:
- Master3 IP:
- Reservation Time:  ms (Valid Range is 0-120000)
- Holdup Time:  ms (Valid Range is 0=indefinite, 300-120000)

 At the bottom of the form are "Save" and "Reset" buttons.

## Master Configurator Web Page

---

### What Is a Master Configurator?

The master configurator of an Advantys STB island controls the configuration data for all of the I/O modules during its reservation time (See *Fields on the Master Configurator Web Page*, p. 81). The configuration master must run the Advantys configuration software. The configuration master can connect to either the fieldbus (Ethernet) interface (See *Fieldbus (Ethernet) Port*, p. 26) or the CFG port (See *The CFG Interface*, p. 33) on the STB NIP 2212.

**Note:** The master configurator of an Advantys STB island must be set up on the Master Configurator web page.

The configuration master of an Advantys STB island can be a:

- local host that resides on the same Ethernet LAN as the island
- remote host that communicates with the Ethernet LAN on which the island resides
- device connecting to the STB NIP 2212, serially, via the CFG port

The master configurator is identified on the Master Configurator web page as follows:

- A master configurator running over the network is identified by its IP address.
- A configuration master connecting to the CFG port is specified as serial (See *Fields on the Master Configurator Web Page*, p. 81).

A master configurator will pre-empt configuration mastery for the Advantys STB island from any other configurator during its reservation time.

---



## Fields on the Master Configurator Web Page

The fields on the Master Configurator web page are described in the following table:

Field	Legal Values	Description
Protocol	IP	The IP address (See <i>How the STB NIP 2212 Obtains IP Parameters</i> , p. 60) of the master configurator on the Ethernet LAN.
	serial	The master configurator is attached to the CFG port on the STB NIP 2212.
	disabled	Disabled is the default setting for this feature. If selected, the master configurator feature is disabled. However, devices normally capable of configuring the island will perform as designed.
reservation time	0 ... 120000 ms, with a 1 ms resolution time	The amount of time in ms allocated to a master for writing configuration data to the STB NIP 2212. Other masters attempting to configure the island during this time will receive an error message. The default reservation time is 60,000 ms (1 min). Reservation time is self-renewing.

## Configuring a Master Configurator for the Island

Use the following procedure to configure a master configurator for an Advantys STB island:

Step	Action
1	Click on the Configuration tab to display the Configuration menu.
2	Select the Master Configurator option.
3	To identify the master configurator, do one of the following: <ul style="list-style-type: none"> <li>Click on the radio button next to the <b>IP</b> option and type in the IP address for the master configurator communicating via the fieldbus (Ethernet) port (See <i>STB NIP 2212 Network Interface</i>, p. 26), e.g., 139.158.2.38 (See <i>Sample Master Configurator Web Page</i>, p. 82).</li> <li>For a master configurator attached to the STB NIP 2212's CFG port (See <i>The CFG Interface</i>, p. 33), click on the radio button next to the <b>Serial</b> option.</li> <li>To disable this feature, click on the radio button next to the <b>Disabled</b> (default) option.</li> </ul>
4	Type a value for the reservation time (0 ... 120000 ms). This is the amount of time allocated to the master configurator for writing configuration data to the island. The default setting is 60000 ms (1 min).
5	Click on the <b>Save</b> button to store the information about the master configurator in the STB NIP 2212's Flash memory and in RAM.

**Sample Master  
Configurator  
Web Page**

A sample Master Configurator web page is shown in the following figure:

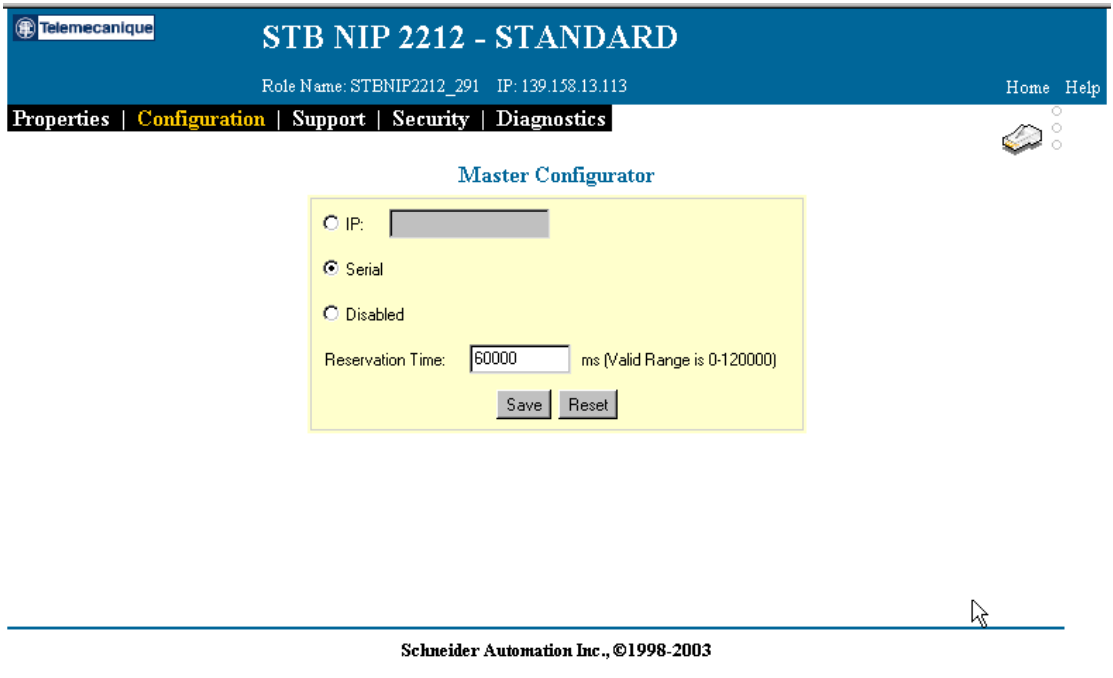

---

## Configuring a Role Name

---

### Introduction

You can assign, edit, or delete a role name for an STB NIP 2212 on the Role Name web page. A role name comprises the STBNIP2212 part number, an underscore (\_), and three numeric characters, e.g., *STBNIP2212\_002*.

A role name is the priority IP address assignment method used by the STB NIP 2212 (See *The IP Address Assignment Process*, p. 63). If a role name is assigned, the IP address for the STB NIP 2212 is always associated with it. You will not be able to assign a configured IP (See *Customer-Configured IP Address*, p. 62) or the default IP address (See *Deriving an IP Address from a Media Access Control (MAC) Address*, p. 61), unless you remove the role name first.

---

### Sample Role Name Web Page

A sample Role Name web page is shown below:

The screenshot shows a web browser window with a blue header bar. On the left is the Telemecanique logo. In the center, the text reads "STB NIP 2212 - STANDARD". Below this, it says "Role Name: STBNIP2212\_010 IP: 205.217.193.95". On the right, there are links for "Home" and "Help". Below the header is a navigation menu with "Properties", "Configuration" (highlighted in yellow), "Support", "Security", and "Diagnostics". To the right of the menu is a small icon of a computer monitor with three circles above it. The main content area is titled "Role Name" and contains a form with a text input field labeled "Role Name:" containing the value "STBNIP2212\_010". Below the input field are two buttons: "Save" and "Reset".

**Configuring a Role Name**

Use the following procedure to create or edit a role name for the STB NIP 2212:

Step	Action	Comment
1	Set the lower rotary switch to an INTERNAL position (See <i>Physical Description, p. 28</i> ), and power cycle the STB NIP 2212.	
2	Open the STB NIP 2212 web site.	
3	Click on the Configuration tab to display the Configuration menu.	
4	Select the Role Name option.	
5	Type or overtype the numeric part of the role name with <i>three</i> numeric values. You can use any numbers in the range 00 to 159 that are not already in use on the same Ethernet LAN.	The default role name is STBNIP2212_000.
6	Click on the <b>Save</b> button to save your role name to the Flash memory and in RAM.	The role name will appear in the banner at the top of each STB NIP 2212 web page. <b>Note:</b> Saving the role name, however, does not configure the STB NIP 2212 with it. You must reboot the STB NIP 2212 (see step 8) to configure it with a role name and to have a DHCP server assign an IP address (See <i>Server-Assigned IP Addresses, p. 62</i> ).
7	Click on the Configuration tab to return to the Configuration menu.	
8	Select the Reboot option (See <i>About the Reboot Option, p. 85</i> ).	
9	At the Reboot now? prompt, click on the <b>OK</b> button.	
10	Click on the <b>OK</b> button at the confirmation prompt, "Are you sure?"	Your STB NIP 2212 restarts. It is configured with the role name and an IP address.

**About the Reboot Option**

The reboot operation will configure the STB NIP 2212 with a role name assigned on the web. Information about the reboot operation appears in the following figure:

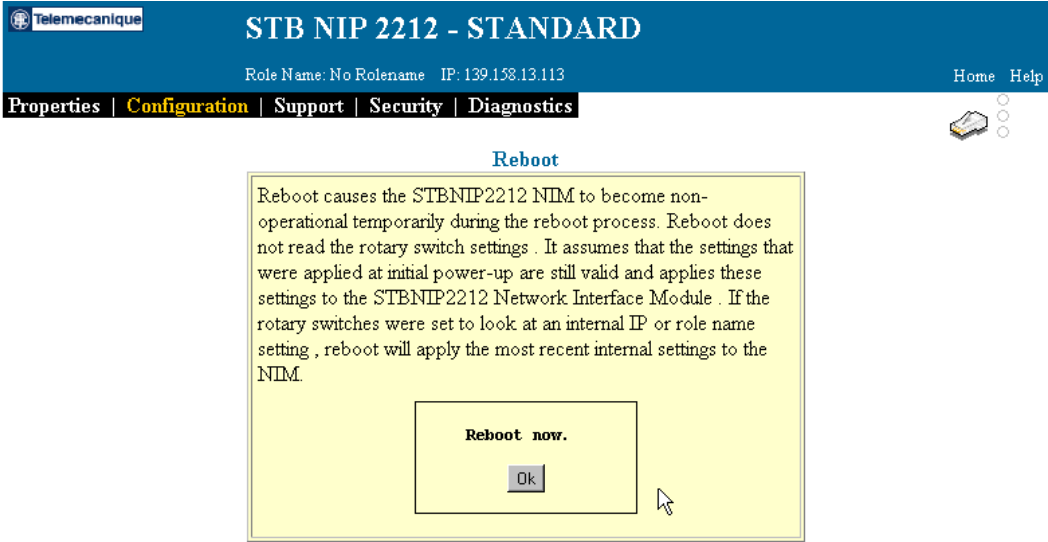

Schneider Electric Inc., ©1998-2003

**Deleting a Role Name**

You must delete a role name before you can assign a configured IP address or the default IP parameters. Use the following steps:

Step	Action
1	Set the lower rotary switch to an INTERNAL position (See <i>Physical Description, p. 28</i> ), and power cycle the STB NIP 2212.
2	Open the STB NIP 2212 web site.
3	Click on the Configuration tab to display the Configuration menu.
4	Select the Role Name option.
5	Highlight the role name to select it. Then press the <b>Delete</b> key on your keyboard.
6	Click on the <b>Save</b> button. <b>Note:</b> The role name is deleted from Flash memory.

## 5.3 Web Server Security

---

### At a Glance

---

#### Introduction

The information in this section describes how the HTTP default password, the web access password, and the configuration password are used to protect the STB NIP 2212 web site.

---

#### What's in this Section?

This section contains the following topics:

Topic	Page
Web Access Password Protection	87
Configuration Password Protection	90

---

## Web Access Password Protection

---

### Summary

The STB NIP 2212 web site is password-protected. Initially, security for the STB NIP 2212 web site is provided by a default user name and password. Any visitor to your STB NIP 2212 site can view all of your information using the default user name and password.

You will want to set up your own user name and password to protect your STB NIP 2212 web site. Use the Change Web Access Password (See *What Is the Web Access Password?*, p. 88) option.

---

### Default User Name and Password

The default name and password for the STB NIP 2212 web site are:

- default user name—USER
- default password—USER

The user name and password are case-sensitive.

Correct entry of the default user name and password authorizes read-only access to your STB NIP 2212 web site. The default (HTTP password) screen is shown in the following figure:

**What Is the Web Access Password?**

The *web access password* is an eight-character, case-sensitive user name and password that you assign. Your values will replace the default protection for your STB NIP 2212 web site. All visitors to your site must correctly complete the web access password dialog box, which is shown in the following figure. The web access dialog box displays immediately after the STB NIP 2212 home page.

The screenshot shows the web interface for 'STB NIP 2212 - STANDARD'. The header is blue with the Telemecanique logo on the left. Below the header, it displays 'Role Name: No Rolename IP: 139.158.13.113' and navigation links for 'Home' and 'Help'. A menu bar contains 'Properties', 'Configuration', 'Support', 'Security' (highlighted in yellow), and 'Diagnostics'. On the right, there is a small icon of a device and three stacked circles. The main content area is titled 'Change Web Access Password' and contains a yellow dialog box with four input fields: 'New User Name', 'Confirm New User Name', 'New Password', and 'Confirm New Password'. Each field is masked with asterisks. At the bottom of the dialog box are 'Save' and 'Reset' buttons.



## Setting Up the Web Access Login

Use the following procedure to set up your web access user name and password:

Step	Action	Result
1	Navigate to your url: <i>http://configured IP address</i> .	The STB NIP 2212 home page is displayed.
2	Enter your language preference. English is the default language. <ul style="list-style-type: none"> <li>● If your language preference is English, click on the <b>Enter</b> button.</li> <li>● To select a different language, click on its name, e.g., Deutsche. Then click on the <b>Enter</b> button.</li> </ul>	The web access password dialog box is displayed.
3	Type <code>USER</code> , using all uppercase letters, in the user name field and then, again, in the password field.	
4	Click on the <b>OK</b> button.	The STB NIP 2212 Properties web page (See <i>Sample Properties Web Page</i> , p. 70) is displayed.
5	Click on the Security tab.	The Security menu is displayed.
6	Select the Change Web Access Password option.	The Change Web Access Password page is displayed.
7	Type the new user name. The user name can have a maximum of eight alphanumeric characters. You can also use an underscore (_). The characters are case-sensitive.	
8	Type the user name again as the value for the Confirm New User Name field.	
9	In the New Password field, type your web access password. The password can have a maximum of eight alphanumeric characters. You can also use an underscore (_). The characters are case-sensitive.	
10	Type the password again in the Confirm New Password field.	
11	Click on the <b>Save</b> button.	The web access user name and password take effect immediately.

## Configuration Password Protection

### Introduction

The configuration password controls *read/write access* from the STB NIP 2212 web site to the physical module's Flash memory. This password must be set up on the Change Configuration Password web page.

### Set Configuration Password Procedure

Use the following procedure to set up a configuration password for your STB NIP 2212 web site:

Step	Action	Result
1	Click on the Security tab.	The Security menu is displayed.
2	Click on the Change Configuration Password option.	The Change Configuration Password page is displayed.
3	In the New Password field, type your configuration password. The password must have six alphanumeric characters. The characters are case-sensitive.	
4	Type the password again in the Confirm New Password field.	
5	Click on the <b>Save</b> button.	The configuration password takes effect immediately.

### Logging In and Out

If you set up a configuration password, the following login procedure takes effect:

Step	Action	Result
1	Type the configuration password for your web site next to the Logout button (See <i>Sample Login Prompt</i> , p. 91). <b>Note:</b> The password is case-sensitive.	The <b>Login</b> button toggles to Logout. <i>Your entire STB NIP 2212 web session is now write enabled.</i>
2	Perform the write operation, e.g., configure a role name from the Role Name web page (See <i>Configuring a Role Name</i> , p. 83).	
3	Click on the <b>Logout</b> button to end write privileges on your web site.	The <b>Logout</b> button toggles to Login. <i>Write protection for your web site is restored.</i>

**Sample Login Prompt**

When active, the login prompt is displayed in the web banner (as shown in the following figure). The six-character configuration password must be entered to proceed:

---

**Synchronizing the Web and Advantys Software Configuration Passwords**

The same password is used to authorize write privileges on the STB NIP 2212 web pages and to configure an Advantys STB island bus with the Advantys configuration software (See *Protecting Configuration Data*, p. 165).

If your island already has a configuration password via the Advantys configuration software, you must use it as the configuration password for your STB NIP 2212 web site, and vice versa.

---

## 5.4 Web Server Diagnostic Options

---

### At a Glance

---

#### Introduction

The information in this section describes the diagnostics options supported by the STB NIP 2212 embedded web server.

---

#### What's in this Section?

This section contains the following topics:

Topic	Page
Diagnostics Web Page	93
Ethernet Statistics	94
STB NIP 2212 Registers Web Page	95
I/O Data Values Web Page	97
Island Configuration Web Page	99
Island Parameters Web Page	100
Error Log Web Page	101

---

# Diagnostics Web Page

**Introduction** The web-based resources that are available for troubleshooting the STB NIP 2212 are listed as options on the Diagnostics menu. The web page for each feature is linked to a menu option.

**Diagnostics Menu** The Diagnostics menu appears in the following figure:

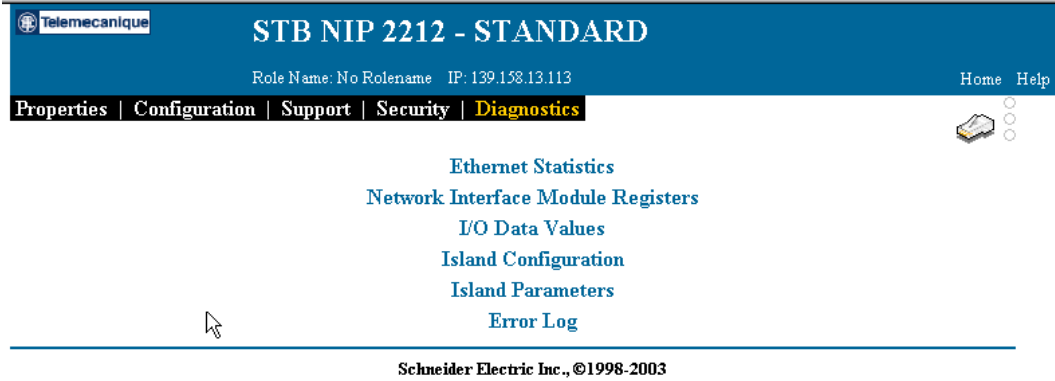

## Accessing the Diagnostics Menu

Use step 1 in the following procedure to access the Diagnostics menu. Then use step 2 to navigate to the web page for a specific diagnostics option.

Step	Action	Result
1	Click on the Diagnostics tab.	The Diagnostics menu is displayed.
2	Click on the option that you want to use, e.g., NIM Registers (See <i>STB NIP 2212 Registers Web Page</i> , p. 95).	The web page for the option that you selected is displayed.

## Ethernet Statistics

### Introduction

The Ethernet Statistics web page reports status information and errors that are related to data transmissions to and from the STB NIP 2212 over the Ethernet LAN.

### Refresh Rate

The statistics on this page are updated at the rate of one per second.

### Sample Ethernet Statistics Web Page

A sample Ethernet Statistics web page appears in the following figure:

The screenshot shows the following data from the Ethernet Statistics page:

Category	Statistic	Value
Receive Statistics	Receive	661
	Framing Error	0
	Overflow Error	0
	CRC Error	0
	Receive Buffer Error	0
Transmit Statistics	Transmit	782
	Transmit Retry	0
	Lost Carrier	0
	Late Collision	0
	Transmit Buffer Error	0
Functioning Errors	Missed Packet	0
	Collision Error	0
	Net Interface Restart	1

- 1 unique role name for this STB NIP 2212.
- 2 unique IP address for this STB NIP 2212.
- 3 unique MAC address for this STB NIP 2212.
- 4 Ethernet statistics—click on the Help button to display a description for each Ethernet statistic.
- 5 Reset button—clicking on this button returns all of the counters to 0.

## STB NIP 2212 Registers Web Page

---

### Summary

The NIM Registers web page will display information about specific Modbus registers in the STB NIP 2212 process image. The registers to display are identified by their Modbus register addresses.

---

### Page Design

The NIM Registers web page is designed to provide a shared view of the specified Modbus registers (See *The Data Image*, p. 167). There is no limit to the number of registers that can be displayed on this web page.

---

### Customized and Common Views

The NIM Registers web page is designed to provide a customized but common view of the STB NIP 2212 process image to everyone viewing the web page.

- **Custom view**—By supplying a personal variable name (maximum 10 characters) and an actual Modbus register location (See *The Data Image*, p. 167), you can customize this page to show the data that is most important to you.
- **Common view**—However, only one view of the NIM Registers can be saved to Flash memory.

After the display on the NIM Registers web page is written to Flash memory (by clicking on the Save button on the page), the display on this web page is fixed, providing a common view.

---

### Using the Command Buttons

The following table describes how to use the command buttons on the NIM Registers web page:

To ...	Click on the ...
add a row to the display.	<b>Add</b> button.
delete one or more row(s) from the display.	checkbox in front of each row that you want to delete; then, click on the <b>Delete</b> button.
save the NIM registers' information from the web page to Flash memory. <b>Note:</b> This operation will overwrite the "save" space in Flash memory with the NIM registers' data displayed on the web page.	<b>Save</b> button.

---

### Format Feature

The format feature allows you to select whether the content of the NIM registers is displayed in decimal or hexadecimal notation.

---

## Sample NIM Registers Web Page

A sample NIM Registers web page appears in the following figure:

**STB NIP 2212 - STANDARD**  
 Role Name: STBNIP2212\_010 IP: 205.217.193.95  
 Home Help

Properties | Configuration | Support | Security | **Diagnostics**

**Network Interface Module Registers**

Variable Name  Add (5)  
 Address  Save (7)

	(1) Variable Name	(2) Address	(3) Value	(6) Format
0	<input type="checkbox"/> variable_1	30090	0	dec
1	<input type="checkbox"/> (4)			dec
2	<input type="checkbox"/>			dec
3	<input type="checkbox"/>			dec
4	<input type="checkbox"/>			dec
5	<input type="checkbox"/>			dec
6	<input type="checkbox"/>			dec
7	<input type="checkbox"/>			dec
8	<input type="checkbox"/>			dec
9	<input type="checkbox"/>			dec

Delete (5)

Schneider Electric Inc., ©1998-2003

- 1 10-character variable name
- 2 Modbus register number
- 3 current value for Modbus register 30090 is 0
- 4 checkbox
- 5 Add and Delete buttons
- 6 format preference—decimal or hexadecimal
- 7 Clicking on the Save button overwrites the designated (single) space in Flash memory with the content of this web page.



## I/O Data Values Web Page

---

### Summary

The I/O Data Values web page will display the values stored in the process image output data area (See *The Output Data Process Image*, p. 119) and input data area (See *The Input Data and I/O Status Process Image*, p. 120) for the I/O modules currently assembled on the island bus. The order of information on this web page is the order of the I/O module assembly, as determined by the auto-addressing (See *Auto-Addressing*, p. 46) and auto-configuration (See *Auto-Configuration*, p. 49) processes.

---

### Page Design

The I/O Data Values web page is designed to accommodate 16 Advantys STB I/O modules (or 256 Modbus registers (See *The Data Image*, p. 167)). The number of modules that can be accommodated will vary according to actual I/O modules assembled on the island. For example, if there are multiple six-channel digital I/O modules (STB DDI 3610s and/or STB DDO 3600s), STB AVI 1270s, STB AVO 1250s, and a specialty module like the STB ART 0200, fewer than 16 modules can be represented on the I/O Data Values web page.

---

**Sample I/O Data Values Web Page** A sample I/O Data Values web page appears in the following figure:

**I/O Data Values**

Node Number	Module Name	Input Address	Input Value	Format	Output Address	Output Value	Format
1	STB AVI 1270	30090	00001100 11001000	bin			dec
	②	30091	④ 0000	hex			dec
		30092	3272	dec			dec
		30093	0	dec			dec
① 2	STB DDI 3610	30094	2	dec			dec
		30095	0	dec			dec
3	STB DDI 3610	30096	1	dec			dec
		30097	0	dec			dec
4	STB DDI 3610	30098	2	dec			dec
		30099	0	dec			dec
5	STB DDI 3610	30100	4	dec			dec
		30101	0	dec			dec
6	STB DDO 3600	30102	4	dec	40001		4 dec
		30103	0	dec			dec
7	STB DDO 3600	30104	2	dec	40002		2 dec
		30105	0	dec			dec

Schneider Electric Inc., ©1998-2003

- 1 module's island bus node address
- 2 Advantys STB part number
- 3 Modbus register location(s) for input and status data
- 4 input values
- 5 format preference—decimal or hexadecimal
- 6 Modbus register location(s) for output data
- 7 output values
- 8 middle light is lit indicating Modbus activity

# Island Configuration Web Page

## Introduction

The Island Configuration web page describes the configuration and operational status (See *Fault Detection, p. 131*) of every module currently assembled on the island bus. The modules are listed in order of their assembly starting with the STB NIP 2212.

## Sample Island Configuration Web Page

A sample Island Configuration web page appears in the following figure:

The screenshot shows a web interface for 'STB NIP 2212 - STANDARD'. At the top, there is a Telemecanique logo and the title. Below the title, it displays 'Role Name: No Rolename IP: 205.217.193.83' and navigation links for 'Home' and 'Help'. A menu bar includes 'Properties', 'Configuration', 'Support', 'Security', and 'Diagnostics'. The main content area is titled 'Island Configuration' and contains a table with the following data:

Node Number	Module Name	Description	Status
127	STB NIP 2212	STB NIP 2212 - STANDARD	Running
1	STB DDI 3420	24VDC IN 4pt sink 3wire .1ms cfg SCP	Operational
2	STB DDO 3600	24VDC OUT 6pt source .5A	Operational
3	STB DDI 3610	24VDC IN 6pt sink 2wire 1ms fixed	Operational
4	STB DDO 3600	24VDC OUT 6pt source .5A	Operational
5	STB DDI 3610	24VDC IN 6pt sink 2wire 1ms fixed	Operational
6	STB DDO 3600	24VDC OUT 6pt source .5A	Operational
7	STB DDI 3610	24VDC IN 6pt sink 2wire 1ms fixed	Operational
8	STB DDI 3610	24VDC IN 6pt sink 2wire 1ms fixed	Operational
9	STB DDI 3610	24VDC IN 6pt sink 2wire 1ms fixed	Operational
10	STB DDI 3610	24VDC IN 6pt sink 2wire 1ms fixed	Operational

## Island Parameters Web Page

### Sample Island Parameters Web Page

The Island Parameters web page displays a read-only list of the island's parameters and their current values. A sample web page appears in the following figure:

The screenshot shows a web interface for the STB NIP 2212 - STANDARD. The header is blue with the Telemecanique logo on the left, the title "STB NIP 2212 - STANDARD" in the center, and "Role Name: No Rolename IP: 139.158.13.113" and "Home Help" on the right. Below the header is a navigation bar with tabs for "Properties", "Configuration", "Support", "Security", and "Diagnostics". A network icon is visible on the right side of the navigation bar. The main content area is titled "Island Parameters" and contains a list of parameters and their values, each in a text input field:

Island State:	RUNNING
Number of Digital I/O Modules:	8
Number of Analog I/O Modules:	1
Number of Other Modules:	0
Memory Card Status:	NOT PRESENT
Configuration Port Status:	NONE
Configuration Port Speed:	9600
Configuration Port Protocol:	RTU
Configuration Port Char Length:	8
Configuration Port Parity:	PARITY_EVEN
Configuration Port Stop Bits:	1

Schneider Electric Inc., ©1998-2003

# Error Log Web Page

**Introduction** System-wide information collected while the Advantys STB island is operational is reported on the Error Log web page.

**Sample Error Log Web Page** A sample Error Log web page appears in the following figure:

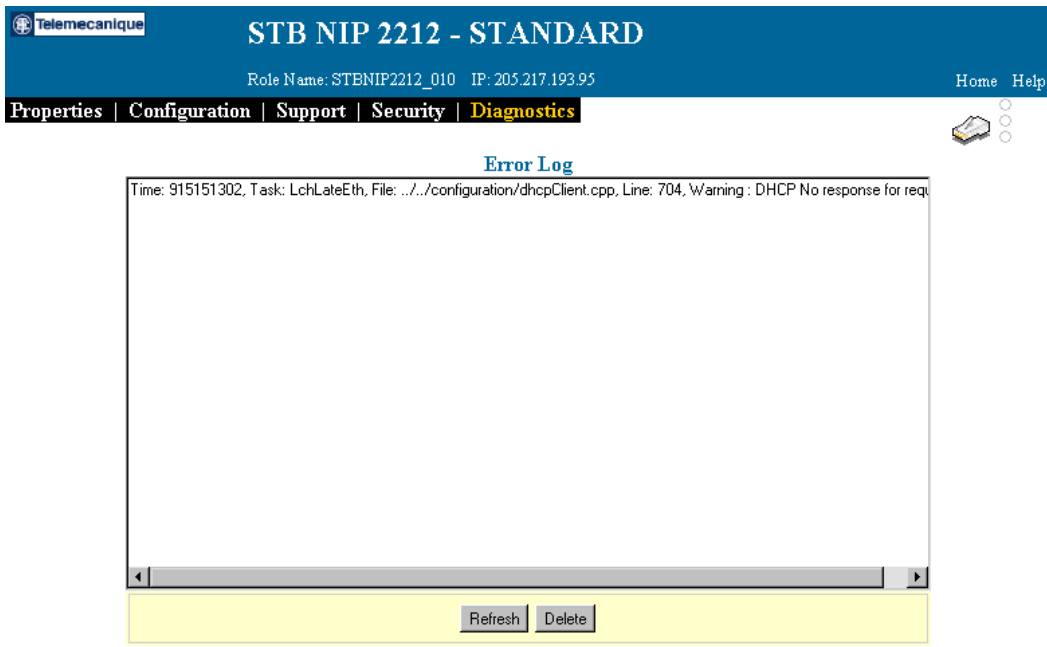

Schneider Electric Inc., ©1998-2003

**Error Log Operations**

The operations associated with the Error Log web page are described in the following table:

To ...	Do ...	Comment
Display the Error Log web page.	Click on the Diagnostics tab to display the Diagnostics menu (See <i>Diagnostics Web Page, p. 93</i> ). Then select the Error Log option.	
Update the display.	Click on the <b>Refresh</b> button.	The error log is not updated automatically. It can only be updated manually.
Delete the log. <b>Caution:</b> Deleting the error log on the web page removes it from Flash memory.	Click on the <b>Delete</b> button.	You must have read/write authorization (See <i>Configuration Password Protection, p. 90</i> ) to delete the error log.

---

---

## 5.5 SNMP Services

---

### At a Glance

---

**Introduction** The STB NIP 2212 contains a Simple Network Management Protocol (SNMP) agent, which is described in this section.

---

**What's in this Section?** This section contains the following topics:

Topic	Page
SNMP Device Management	104
Configure SNMP Web Page	106
About the Schneider Private MIBs	108
Transparent Factory Ethernet (TFE) MIB Subtree	110
Port502 Messaging Subtree	111
Web MIB Subtree	112
Equipment Profiles Subtree	113

---

## SNMP Device Management

---

### Introduction

The STB NIP 2212 contains a Simple Network Management Protocol (SNMP) Version 1.0 *agent* that is capable of supporting up to three concurrent SNMP connections.

---

### User Datagram Protocol (UDP)

On the STB NIP 2212, SNMP services are delivered via the UDP/IP stack. UDP is the transport protocol used by the SNMP application in its communications with the STB NIP 2212.

**Note:** BootP and the DHCP applications also use UDP as their transport layer when communicating with the STB NIP 2212.

---

### SNMP Agents and Managers

The SNMP network management model uses the following terminology and definitions:

- manager—the client application program running on the master
- agent—the server application running on a network device, in this case, the STB NIP 2212

The SNMP manager initiates communications with the agent. An SNMP manager can query, read data from and write data to other host devices. An SNMP manager uses UDP to establish communications with an *agent device* via an "open" Ethernet interface.

When the STB NIP 2212 is successfully configured with SNMP, the STB NIP 2212 agent and the SNMP manager devices can recognize one another on the network. The SNMP manager can then transmit data to and retrieve data from the STB NIP 2212.

---

### Network Management Application

SNMP software allows an SNMP manager (remote PC) to monitor and control the STB NIP 2212. Specifically, SNMP services are used to monitor and manage:

- performance
  - faults
  - configuration
  - security
-



**SNMP Protocol Data Units (PDUs)**

Protocol Data Units (PDUs) within SNMP carry requests and responses between the manager and the STB NIP 2212 agent. The following PDUs are used:

- GetRequest—An SNMP manager uses the "Get" PDU to read the value of one or more management information base (MIB) (See *Management Information Base (MIB), p. 108*) objects from the STB NIP 2212 agent.
- SetRequest—An SNMP manager uses the "Set" PDU to write a value to one or more objects resident on the STB NIP 2212 agent.

These PDUs are used in conjunction with MIB objects to get and set information contained in an Object Identifier (OID).

**SNMP PDU Structure**

An SNMP message is the innermost part of a typical network transmission frame, as shown in the following illustration:

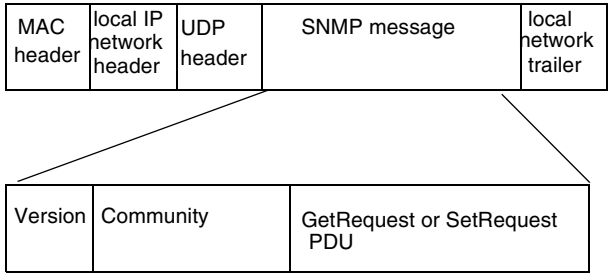

**Version & Community Identifiers**

The STB NIP 2212 is configured with SNMP, Version 1.0. When setting up the SNMP agent function for your STB NIP 2212 (See *Configure SNMP Web Page, p. 106*), you should configure private community name(s) for GetRequest and SetRequest.

**Note:** If you do not configure private community names for GetRequest and SetRequest, any SNMP manager can read the MIB objects for your STB NIP 2212.

The community name is an identifier that you assign to your SNMP network when you set up the SNMP manager. Community names for the SNMP manager and agent must agree before SNMP processing can occur.

## Configure SNMP Web Page

### Introduction

The Configure SNMP web page allows you to view the parameters used by the SNMP agent contained in the STB NIP 2212.

### Fields on the Configure SNMP Web Page

The parameters and the settings for the SNMP agent are described in the following table:

Purpose	Field Name	Description
Agent	Location	100-character, case-sensitive alphanumeric string describing the location of this STB NIP 2212 (agent device).
	Contact	100-character, case-sensitive alphanumeric string identifying the contact person for this STB NIP 2212.
Community	Set	100-character, case-sensitive alphanumeric community string used to write the value of a point of information. A SetRequest is used by an SNMP manager to write to the STB NIP 2212. The default community name for the STB NIP 2212 is <code>public</code> . <b>Note:</b> If you enable an Authentication Failure Trap, assign a private community string for SetRequest.
	Get	100-character, case-sensitive alphanumeric community string, assigned by the user and used by the master to read the value of a point of information provided by the STB NIP 2212. The default community name for the STB NIP 2212 is <code>public</code> . <b>Note:</b> If you enable an Authentication Failure Trap, assign a private community string for a Get Request. <i>If you do not assign a private community string for this field, any SNMP manager can read the MIB objects for your STB NIP 2212.</i>
	Trap	A trap is an exception report from an agent notifying the SNMP manager of an event or parameter change. Used by SNMP managers listening for traps to determine with which community the trap is associated. If a network device has a configurable SNMP manager, the manager can be set up to receive specific traps based on the community string.
Security	Trap Enabled	Authentication failure trap. Schneider Electric recommends that you always enable the trap.

## Sample Configure SNMP Web Page

A sample Configure SNMP web page is shown in the following figure:

**Telemecanique** **STB NIP 2212 - STANDARD**

Role Name: No Rolename IP: 139.158.13.113 Home Help

**Properties** | **Configuration** | Support | Security | Diagnostics

**Configure SNMP**

**System Description:** TF Ethernet NIM standard

**System Name:** STB NIP 2212

<b>Manager 1:</b>	<input type="text"/>	<b>Set:</b>	<input type="text" value="private"/>
<b>Manager 2:</b>	<input type="text"/>	<b>Get:</b>	<input type="text" value="private"/>
<b>Location:</b>	<input type="text" value="Bldg 8, MS 7-2B"/>	<b>Trap:</b>	<input type="text" value="private"/>
<b>Contact:</b>	<input type="text" value="misty"/>	<b>Trap Enable:</b>	<input checked="" type="checkbox"/>

## About the Schneider Private MIBs

---

### Introduction

The following information describes the Schneider Electric private MIB, and the Transparent Factory Ethernet (TFE) and other subtrees that apply to the STB NIP 2212.

The STB NIP 2212 uses the MIB II standard.

---

### Management Information Base (MIB)

The Management Information Base (MIB) is an international communications database in which each object that SNMP accesses is listed with a unique name and its definition. Both SNMP manager and agent applications access the MIB. Each MIB contains a finite number of objects. A management station (PC) running an SNMP application uses sets (See *Fields on the Configure SNMP Web Page, p. 106*) and gets (See *Fields on the Configure SNMP Web Page, p. 106*) to set system variables and to retrieve system information.

---

### Schneider Private MIB

Schneider Electric has a private MIB, Groupe\_Schneider (3833). 3833 is a private enterprise number (PEN) assigned to Groupe\_Schneider by the Internet Assigned Numbers Authority (IANA). The number represents a unique object identifier (OID) for Groupe\_Schneider.

The OID for the root of the Groupe\_Schneider subtree is 1.3.6.1.4.1.3833. This OID represents a path to the TFE subtree as follows:

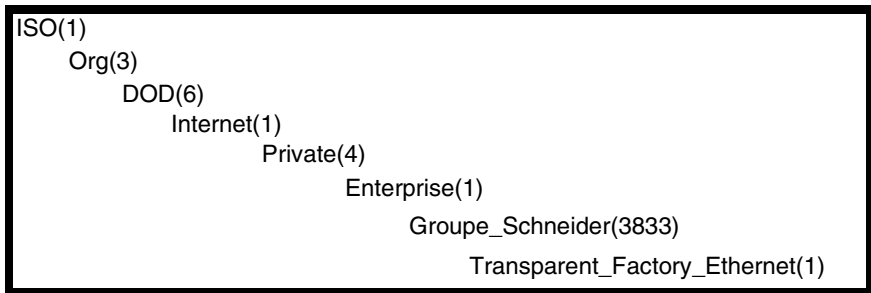

**Transparent  
Factory Ethernet  
(TFE) Subtree**

Under the Groupe\_Schneider MIB is a Transparent\_Factory\_Ethernet (TFE) private MIB that is controlled by the TFE SNMP embedded component. All SNMP managers that communicate with an Advantys STB island via an SNMP agent use the object names and definitions exactly as they appear in the TFE private MIB:

```
Groupe_Schneider(3833)
  Transparent_Factory_Ethernet(1)
    Switch(1)
    Port502_Messaging (2)
    I/O_Scanning (3)
    Global_Data (4)
    Web (5)
    Address_Server (6)
    Equipment_Profiles (7)
```

## Transparent Factory Ethernet (TFE) MIB Subtree

---

### Introduction

The Transparent Factory Ethernet (TFE) private is a subtree of the Groupe\_Schneider private MIB. The TFE SNMP component controls Groupe\_Schneider's private MIB function. Via its associated network communications services, the Groupe\_Schneider private MIB manages and monitors all of the Advantys STB system components.

The TFE MIB provides data to manage the main TFE communications services for the communication components that are part of the TFE architecture. The TFE MIB does not define specific management applications and policies.

---

### Transparent Factory Ethernet (TFE) MIB Subtree

The Transparent\_Factory\_Ethernet(1) defines groups that support TFE services and devices:

Service	Description
Port 502_Messaging(2)	subtree that defines objects for managing explicit client/server communications
web(5)	subtree that defines objects for managing embedded web server activity
equipment_profiles(7)	subtree that identifies objects for each type of device in the TFE product portfolio
Note: Numbers such as 1, 2, 5, and 7 are OIDs.	

---

## Port502 Messaging Subtree

### Introduction

Port502 services support TFE services. Port502 services manage explicit client/server communications that support applications, e.g., HMI data communications. Every Port502 SAP is associated with a unique object in the Port502 MIB subtree.

### Port502 MIB Subtree

The Port502\_Messaging subtree (OID 5) provides connection management and data flow services to the STB NIP 2212. The following table includes the port502 objects and OIDs used by a TFE service:

Service	Indication for Port 502	Available Values
port502Status(1)	status of the service	idle
		operational
port502 SupportedProtocol(2)	supported protocols	2
port502IPSecurity(3)	status of IP security	disabled–default
		enabled
port502MaxConn(4)	max. no. of TCP connections supported	33
port502LocalConn(5)	no. of local TCP connections currently active	always 0
port502RemConn(6)	no of rport502 connections that are currently active	0 ... 32
port502 IPSecurityTable(7)	table containing the total no. of unsuccessful TCP connection attempts by a remote device	
port502ConnTable(8)	table containing Port 502-specific information	MsgIn
		MsgOut
port502MsgIn(9)	total number of Port 502 messages received from the network	
port502MsgOut(10)	total number of Port 502 messages sent to the network	
port502MsgOutErr(11)	total number of error messages sent to the network from Port 502	
port502AddStackStat(12)	support of additional stack statistics	disabled
		enabled
port502AddStackStatTable(13)	additional stack statistics (optional)	

## Web MIB Subtree

---

### Introduction

The Web MIB subtree, OID 5, defines objects for managing embedded web server activity.

---

### Web MIB Subtree

The following table describes the objects in the Web subtree that support Ethernet services used by the Advantys STB system:

Service	Indication	Available Values
webStatus(1)	global status of the web service	1-idle
		2-operational
webPassword(2)	switch to enable/disable use of web passwords	1-disabled (see table note)
		2-enabled
webSuccessfulAccess(3)	total number of successful accesses to the STB NIP 2212 web site	
webFailedAttempts(4)	total number of unsuccessful attempts to access the STB NIP 2212 web site	
<b>Note:</b> Disabling the webPassword service will disable the default HTTP password (See <i>Default User Name and Password, p. 87</i> ) for the STB NIP 2212 embedded web server.		

---



## Equipment Profiles Subtree

### Introduction

The Equipment\_Profiles subtree (OID 7) identifies objects for every device type in the TFE product portfolio.

### Equipment Profiles MIB Subtree

The following table describes the objects contained in the Equipment Profiles MIB subtree (group) that are common to all TFE products:

Service	Description	Comment
profile Product Name(1)	displays the commercial name of the communication product as a string	e.g., STB NIP 2212
profileVersion(2)	displays software version of STB NIP 2212	e.g., Vx.y or V1.1
profileCommunicationServices (3)	displays list of communication services supported by the profile	e.g., Port502Messging, Web
profileGlobalStatus(4)	indicates global_status of the STB NIP 2212	available values <ul style="list-style-type: none"> <li>● 1–nok</li> <li>● 2–ok</li> </ul>
profileConfigMode(5)	indicates the IP configuration mode of the STB NIP 2212	available values <ul style="list-style-type: none"> <li>● 1–local: the IP configuration is created locally</li> <li>● 2–DHCP-served: the IP configuration is created remotely by a DHCP server</li> </ul>
profileRoleName(6)	indicates role name for IP address management	if none, value is <i>no role name</i>
profileBandwidthMgt(7)	indicates the status of bandwidth management	value is always disabled
profileBandwidthDistTable(8)		not available
profileLEDDisplayTable(9)	displays a table giving the name and state of each module's LEDs	refer to the STB NIP 2212 LEDs discussion (See <i>LED Indicators, p. 30</i> )
profileSlot(10)		value=127
profileCPUType(11)		Advantys STB

<b>Service</b>	<b>Description</b>	<b>Comment</b>
profileTrapTableEntries Max(12)		managers not required; value is 0
profileTrapTable(13)		not used
profileSpecified(14)		255
profileIPAddress(15)		IP address in use
profileNetMask(16)	subnet mask associated with SNMP agent's IP address	
profileIPGateway(17)	default gateway IP address for the SNMP agent	
profileMacAddress(18)	Ethernet media dependent address of the SNMP agent	

---

---

# Data Exchange



---

## At a Glance

### Introduction

This chapter describes how data stored in the process image is exchanged between the STB NIP 2212 and the Ethernet network, via Modbus over TCP/IP.

### What's in this Chapter?

This chapter contains the following topics:

Topic	Page
Data Exchange with the STB NIP 2212	116
Reading Diagnostic Data	125
Modbus Commands Supported by the STB NIP 2212	133

## Data Exchange with the STB NIP 2212

---

**Introduction** Data exchange between a Modbus over TCP/IP host or the HTTP embedded web server and the Advantys STB island bus is conducted over the Ethernet port on the STB NIP 2212.

---

**Master Devices** The input and output data image areas (See *The Island's Process Image Blocks, p. 169*) can be accessed and monitored over the Ethernet LAN by a Modbus over TCP/IP fieldbus master or the STB NIP 2212 HTTP embedded web server.

The Ethernet port on the STB NIP 2212 is configured as follows:

- Port 502 SAP—Modbus over TCP/IP
- Port 80 SAP—HTTP
- Port 161 SAP—SNMP

**Note:** An HMI panel or a device running the Advantys configuration software can also exchange data with an island via the CFG port (See *The CFG Interface, p. 33*) on the STB NIP 2212.

---

**Modbus over TCP/IP Communications** Master devices use Modbus messaging (See *List of Supported Commands, p. 134*) to read and write data to specific registers in the process image. The Modbus protocol is understood regardless of the network type. The Modbus protocol uses a 16-bit word data format.

---

**Data Exchange Process** Data stored in the process image is exchanged between the STB NIP 2212 and the Ethernet network via Modbus over TCP/IP. First, data from the Ethernet host is written to the output data image area (See *The Output Data Process Image, p. 119*) in the NIM's process image. Then, status, echo output, and input data information from the I/O modules on the island are placed in the input data image area (See *The Input Data and I/O Status Process Image, p. 120*). In this location, the Modbus master can access them over the TCP/IP network, or over the CFG port. Data within the output and the input areas of the process image is organized in the order that the I/O modules are assembled (See *A Data Exchange Example, p. 117*) on the island bus.

---

## Data and Status Objects

Data exchange between the island and the fieldbus master involves three object types:

- *data* objects, which are operating values that the master either reads from the input modules or writes to the output modules
- *status* objects, which are module health records sent to the input area of the process image by all of the I/O modules and read by the master
- *echo output data* objects, which the digital output modules send to the input process image; these objects are usually a copy of the data objects, but they can contain useful information if a digital output channel is configured to handle the result of a reflex action.

## A Data Exchange Example

The example uses the sample island bus assembly, as illustrated in the following figure. The sample island comprises the STB NIP 2212 NIM, eight Advantys STB I/O modules, a 24 VDC PDM, and an STB XMP 1100 termination plate:

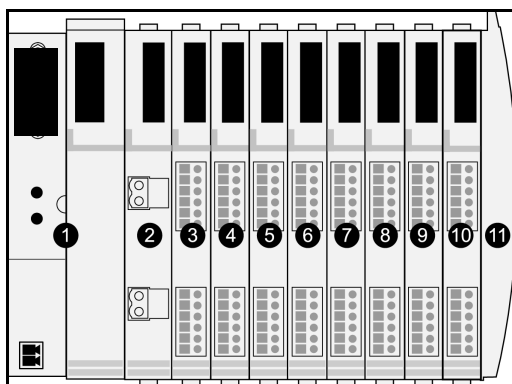

- 1 STB NIP 2212 network interface module
- 2 24 VDC power distribution module
- 3 STB DDI 3230 24 VDC two-channel digital input module
- 4 STB DDO 3200 24 VDC two-channel digital output module
- 5 STB DDI 3420 24 VDC four-channel digital input module
- 6 STB DDO 3410 24 VDC four-channel digital output module
- 7 STB DDI 3610 24 VDC six-channel digital input module
- 8 STB DDO 3600 24 VDC six-channel digital output module
- 9 STB AVI 1270 +/-10 VDC two-channel analog input module
- 10 STB AVO 1250 +/-10 VDC two-channel analog output module
- 11 STB XMP 1100 island bus termination plate

The I/O modules have the following island bus addresses:

<b>I/O Model</b>	<b>Module Type</b>	<b>Module's Island Bus Address</b>
STB DDI 3230	two-channel digital input	N1
STB DDO 3200	two-channel digital output	N2
STB DDI 3420	four-channel digital input	N3
STB DDO 3410	four-channel digital output	N4
STB DDI 3610	six-channel digital input	N5
STB DDO 3600	six-channel digital output	N6
STB AVI 1270	two-channel analog input	N7
STB AVO 1250	two-channel analog output	N8

The PDM and the termination plate are not addressable (See *Addressable Modules*, p. 46), so they exchange neither data objects nor status objects with the fieldbus master.

---

## The Output Data Process Image

The output data process image contains the data written to the island from the Modbus over TCP/IP host. This data is used to update the output modules on the island bus. In the sample island bus assembly, there are four output modules—three digital output modules and one analog output module.

Each digital output module uses one Modbus register for its data. The analog output module requires two registers, one for each output channel. Therefore, a total of five registers (registers 40001 through 40005) are needed to accommodate the four output modules in the sample island bus assembly.

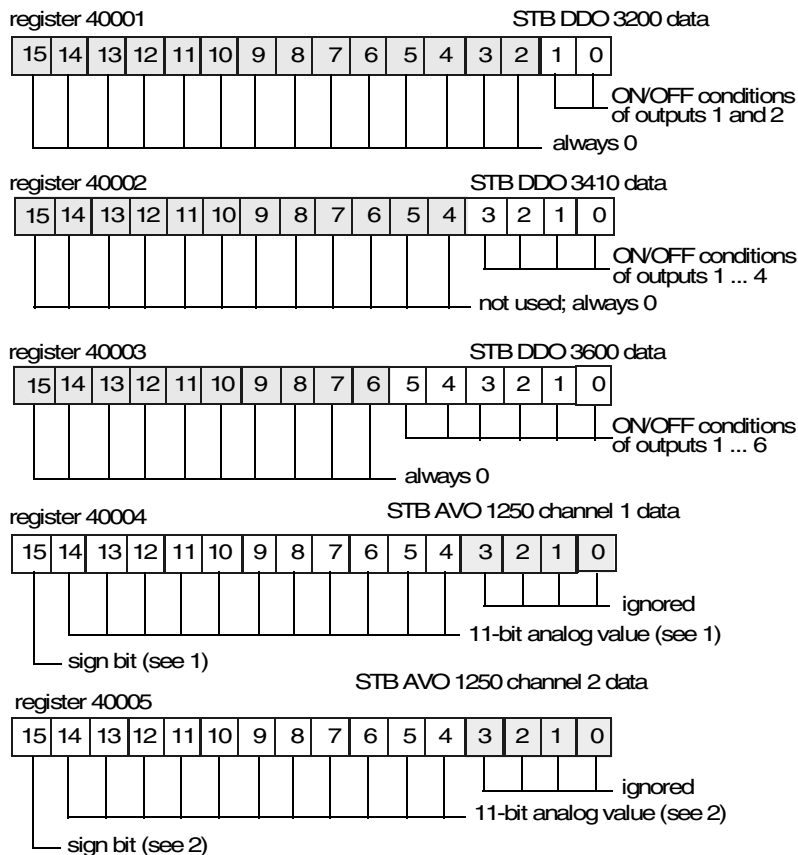

- 1 The value represented in register 40004 is in the range +10 to -10 V, with 11-bit resolution plus a sign bit in bit 15.
- 2 The value represented in register 40005 is in the range +10 to -10 V, with 11-bit resolution plus a sign bit in bit 15.

The digital modules use the LSBs to hold and display their output data. The analog module uses the MSBs to hold and display its output data.

### The Input Data and I/O Status Process Image

Input data and I/O status information from the I/O modules are sent to the input process image area. The fieldbus master or another monitoring device, e.g., an HMI panel (See *The HMI Blocks in the Island Data Image, p. 172*), can view data in the input data image area.

All eight I/O modules are represented in the input process image area. Their assigned registers start at register 45392 and continue in the order of their island bus addresses.

A digital I/O module uses two contiguous registers:

- Digital input modules use one register to report data and the next to report status.
- Digital output modules use one register to report echo output data and the next to report status.

**Note:** The value in an *echo output data* register is basically a copy of the value written to the corresponding register in the output data process image area (See *The Output Data Process Image, p. 119*). Generally, the fieldbus master writes this value to the NIM, and the echo is of not much interest. If an output channel is configured to perform a reflex action (See *What Is a Reflex Action?, p. 157*), however, the echo register provides a location where the fieldbus master can view the current value of the output.

The analog input module uses four contiguous registers:

- the first register to report the data for channel 1
- the second register to report status for channel 1
- the third register to report the data for channel 2
- the fourth register to report status for channel 2

The analog output module uses two contiguous registers:

- the first register to report status for channel 1
- the second register to report status for channel 2



In total, the Modbus over TCP/IP sample island bus requires 18 registers (registers 45392 through 45409) to support our configuration:

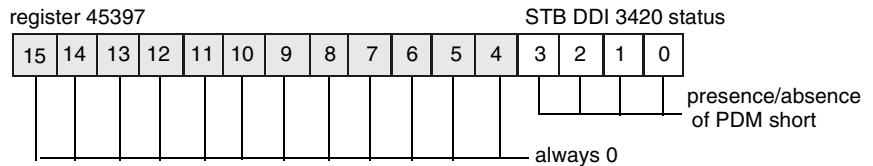
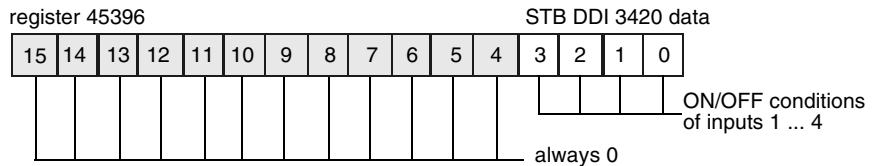
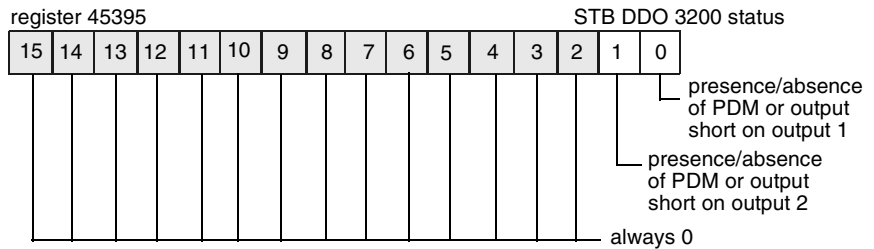
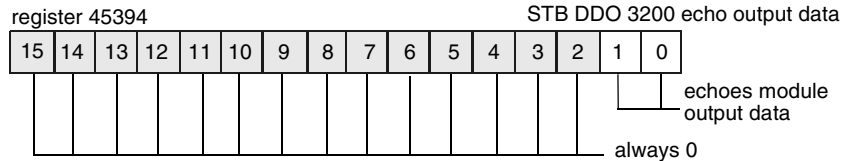
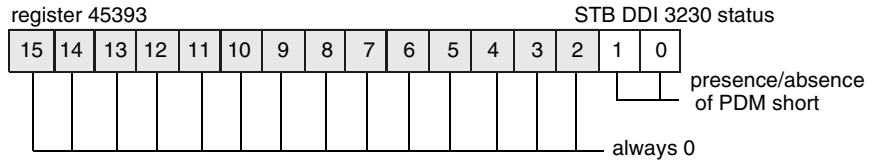
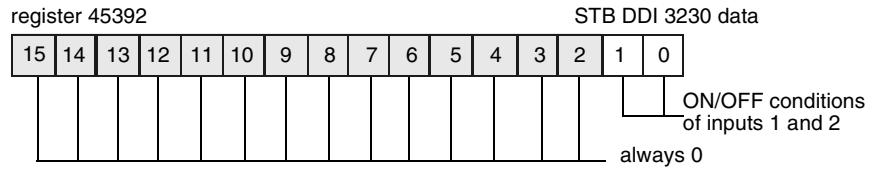



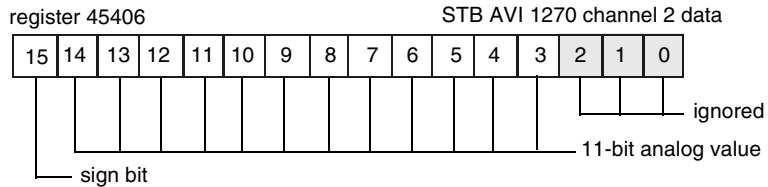
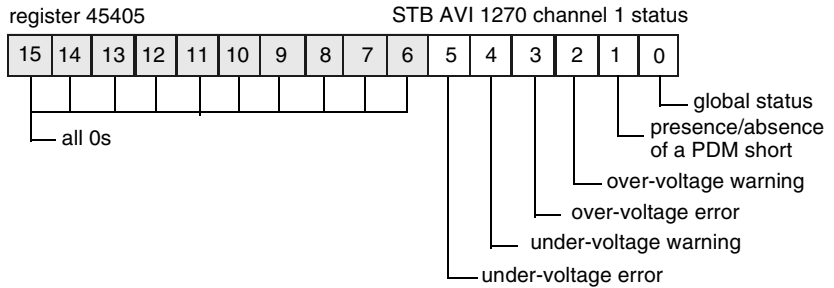
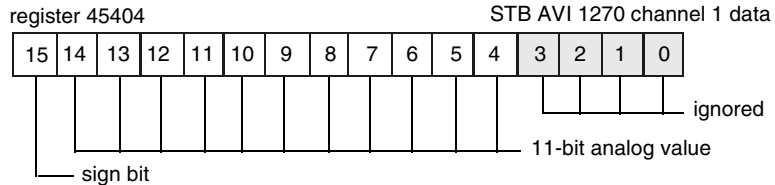
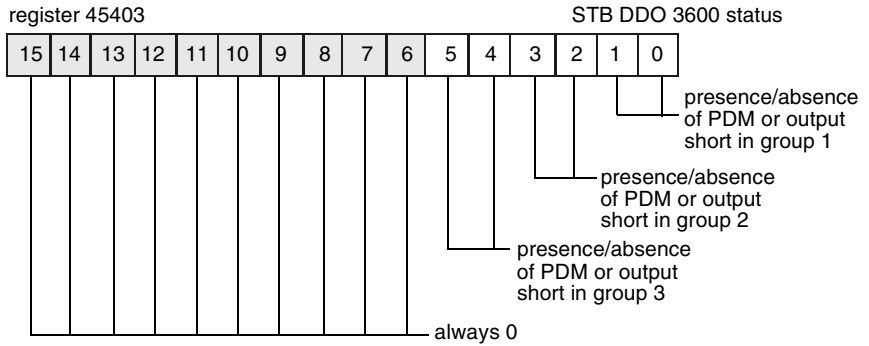

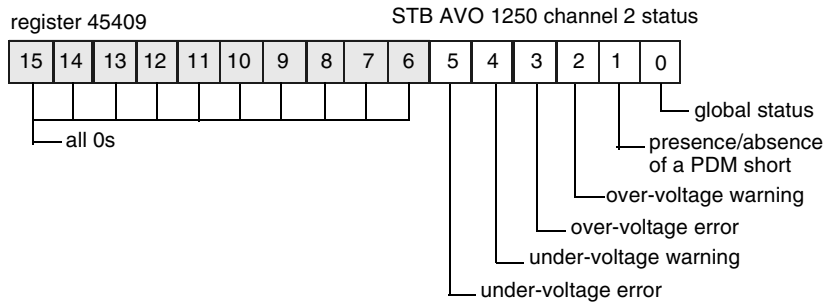
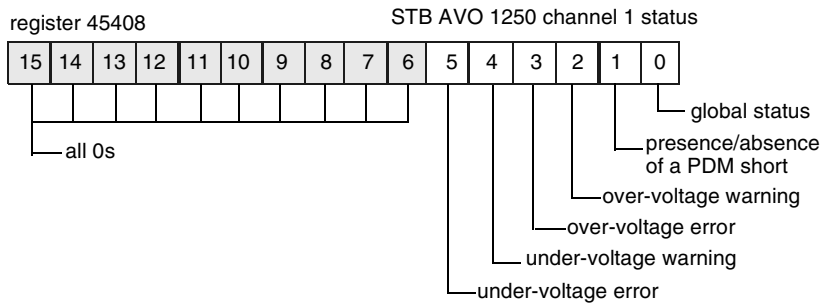
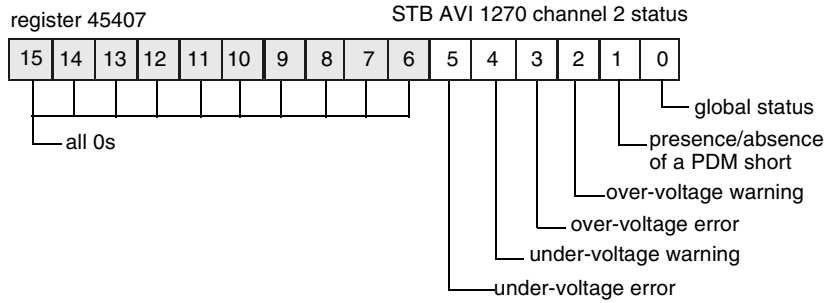

## Reading Diagnostic Data

### Summary

Thirty-five contiguous registers (45357 through 45391) in the island bus data image (See *The Data Image*, p. 167) are reserved for diagnostic data about the Advantys STB system. The diagnostic registers have pre-defined meanings, which are described below.

### Master Devices

The diagnostic registers can be monitored by a Modbus over TCP/IP host or the STB NIP 2212 embedded web server. The master devices use Modbus messaging (See *List of Supported Commands*, p. 134) to read and write diagnostic data to specific registers in the diagnostic block of the process image.

**Note:** An HMI panel or a device running the Advantys configuration software can also exchange data with an island via the (CFG) port (See *The CFG Interface*, p. 33) on the STB NIP 2212.

### Island Communications Status

Status information about the state of communications across the island bus is stored in register 45357. The bits in the low byte (bits 7 through 0) use fifteen different patterns to indicate the island's current communications' state. Each bit in the high byte (bits 15 through 8) indicates the presence or absence of a specific error condition:

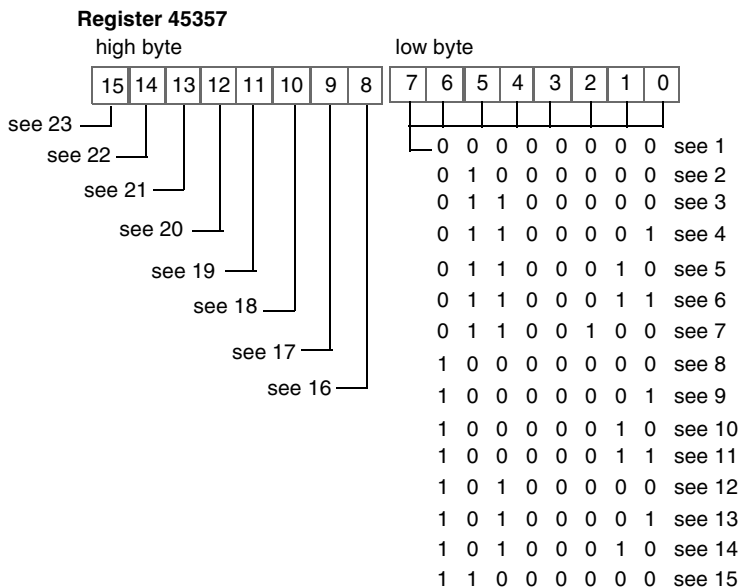

- 1** The island is initializing.
- 2** The island has been set to pre-operational mode, for example, by the reset function.
- 3** The STB NIP 2212 is configuring or auto-configuring—communication to all modules is reset.
- 4** The STB NIP 2212 is configuring or auto-configuring—checking for any modules that are not auto-addressed.
- 5** The STB NIP 2212 is configuring or auto-configuring—Advantys STB and preferred modules are being auto-addressed.
- 6** The STB NIP 2212 is configuring or auto-configuring—boot-up is in progress.
- 7** The process image is being set up.
- 8** Initialization is complete, the island bus is configured, the configuration matches, and the island bus is not started.
- 9** Configuration mismatch—non-mandatory or unexpected modules in the configuration do not match, and the island bus is not started.
- 10** Configuration mismatch—at least one mandatory module does not match, and the island bus is not started.
- 11** Serious configuration mismatch—the island bus has been set to pre-operational mode, and initialization is aborted.
- 12** The configuration matches, and the island bus is operational.
- 13** The island is operational with a configuration mismatch. At least one standard module does not match, but all the mandatory modules are present and operating.
- 14** Serious configuration mismatch—the island bus was started but is now in pre-operational mode because of one or more mismatched mandatory module(s).
- 15** The island has been set to pre-operational mode, for example, by the stop function.
- 16** A value of 1 in bit 8 is a fatal error. It indicates a low-priority receive queue software overrun error.
- 17** A value of 1 in bit 9 is a fatal error. It indicates a NIM overrun error.
- 18** A value of 1 in bit 10 indicates an island bus-off error.
- 19** A value of 1 in bit 11 is a fatal error. It indicates that the error counter in the NIM has reached the warning level and the error status bit has been set.
- 20** A value of 1 in bit 12 indicates that the NIM's error status bit has been reset.
- 21** A value of 1 in bit 13 is a fatal error. It indicates a low-priority transfer queue software overrun error.
- 22** A value of 1 in bit 14 is a fatal error. It indicates a high-priority receive queue software overrun error.
- 23** A value of 1 in bit 15 is a fatal error. It indicates a high-priority transfer queue software overrun error.

**Error Reporting**

Each bit in register 45358 indicates a specific global error condition. A value of 1 indicates an error:

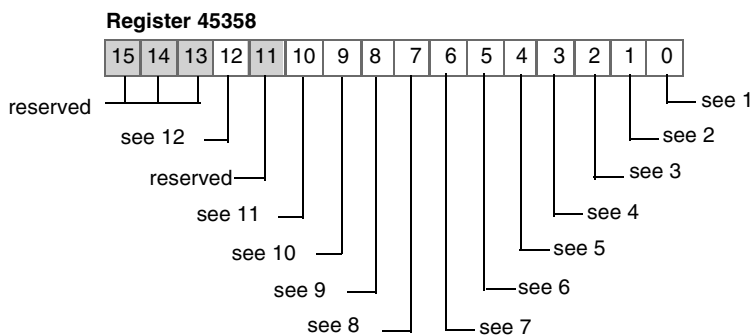

- 1 Fatal error. Because of the severity of the error, no further communications are possible on the island bus.
- 2 Module ID error—A standard CANopen device is using a module ID reserved for the Advantys STB modules.
- 3 Auto-addressing has failed.
- 4 Mandatory module configuration error.
- 5 Process image error—either the process image configuration is inconsistent, or it could not be set up during auto-configuration.
- 6 Auto-configuration error—a module is not in its configured location, and the NIM cannot complete auto-configuration.
- 7 An island bus management error was detected by the NIM.
- 8 Assignment error—the initialization process in the NIM has detected a module assignment error.
- 9 Internal triggering protocol error.
- 10 Module data length error.
- 11 Module configuration error.
- 12 Timeout error.

**Node Configuration**

The next eight contiguous registers (registers 45359 through 45366) display locations where modules have been configured on the island bus. This information is stored in Flash memory. At start up, the actual locations of the modules on the island are validated by comparing them to the configured locations stored in memory. Each bit represents one configured location:

- A value of 1 in a bit indicates that a module has been configured for the associated location.
- A value of 0 in a bit indicates that a module has not been configured for the associated location.

The first two registers, shown below, provide the 32 bits that represent the module locations available in a typical island configuration. The remaining six registers (45361 through 45366), are available to support the island's expansion capabilities:

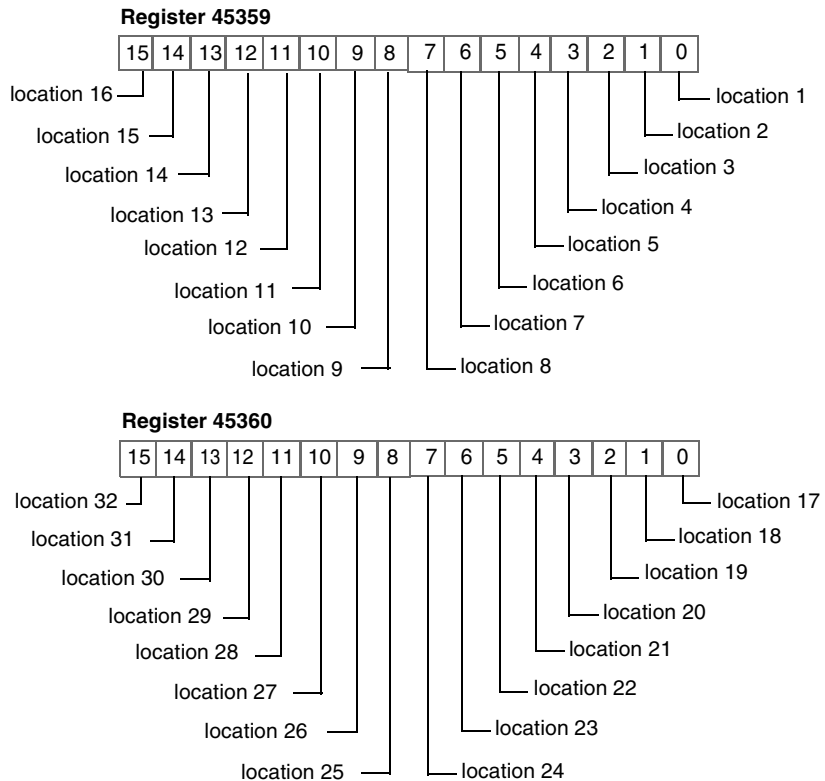



**Node Assembly**

The next eight contiguous registers (registers 45367 through 45374) indicate the presence or absence of configured modules in locations on the island bus. This information is stored in Flash memory. At start up, the actual locations of the modules on the island are validated by comparing them to the configured locations stored in memory. Each bit represents a module:

- A value of 1 in a given bit indicates that the configured module is not present.
- A value of 0 indicates that the correct module is present in its configured location, or that the location has not been configured.

The first two registers, shown below, provide the 32 bits that represent the module locations available in a typical island configuration. The remaining six registers (45369 through 45374) are available to support the island's expansion capabilities:

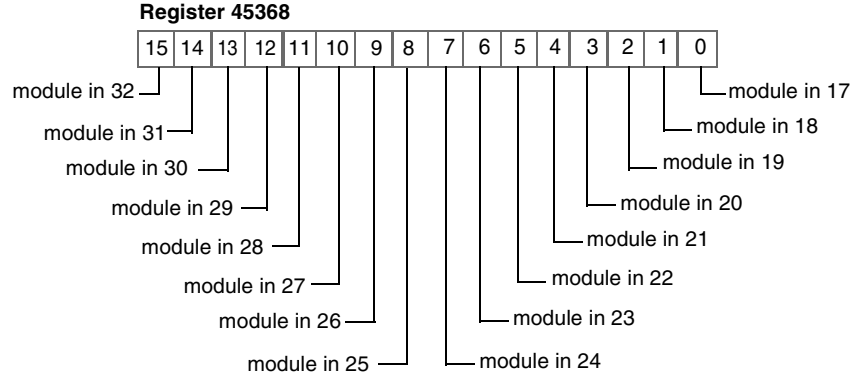
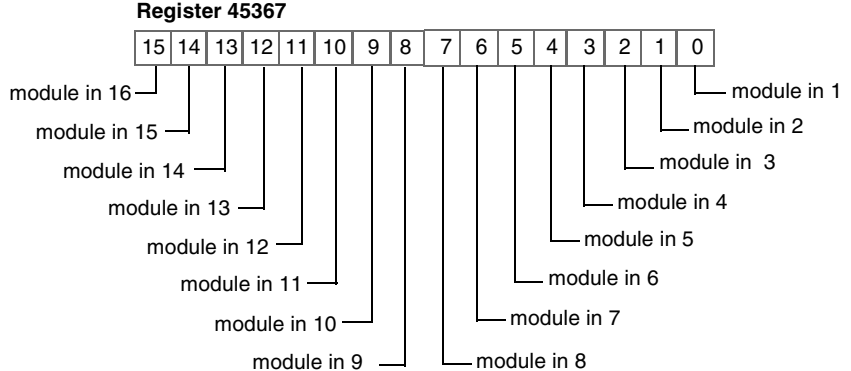

## Emergency Messages

The next eight contiguous registers (registers 45375 through 45382) indicate the presence or absence of newly received emergency messages for individual modules on the island. Each bit represents a module:

- A value of 1 in a given bit indicates that a new emergency message has been queued for the associated module.
- A value of 0 in a given bit indicates that no new emergency messages have been received for the associated module since the last time the diagnostic buffer was read.

The first two registers, shown below, provide the 32 bits that represent the module locations available in a typical island configuration. The remaining six registers (45377 through 45382) are available to support the island's expansion capabilities:

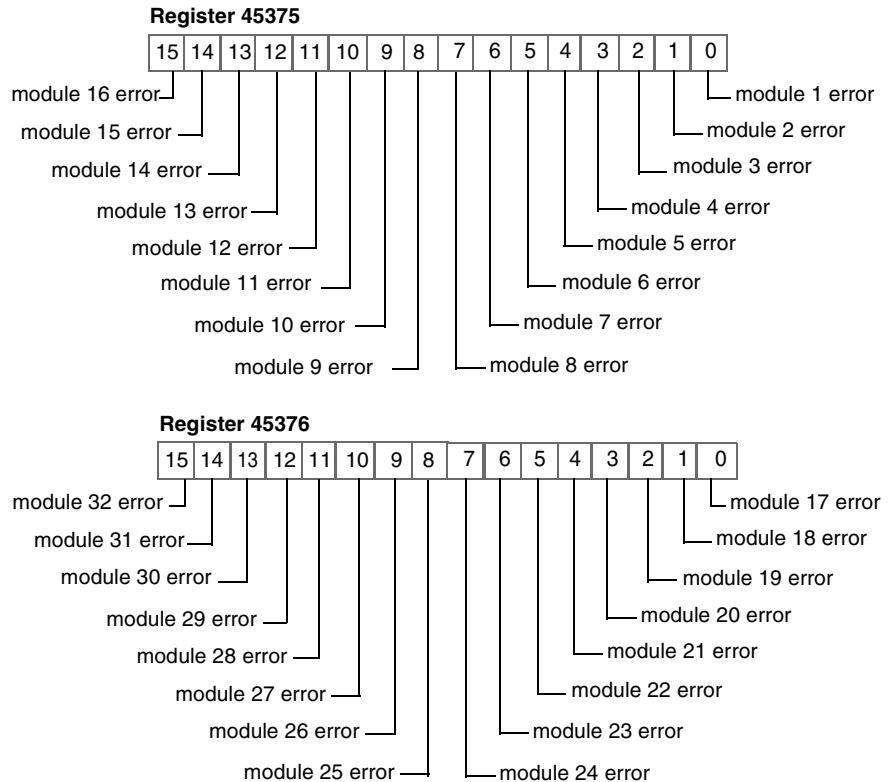

**Fault Detection**

The next eight contiguous registers (registers 45383 through 45390) indicate the presence or absence of operational faults detected on the island bus modules. Each bit represents a module:

- A value of 1 in a bit indicates that the associated module is operating and that no faults were detected.
- A value of 0 in a bit indicates that the associated module is not operating either because it has a fault or because it has not been configured.

The first two registers, shown below, provide the 32 bits that represent the module locations available in a typical island configuration. The remaining six registers (45385 through 45390) are available to support the island's expansion capabilities:

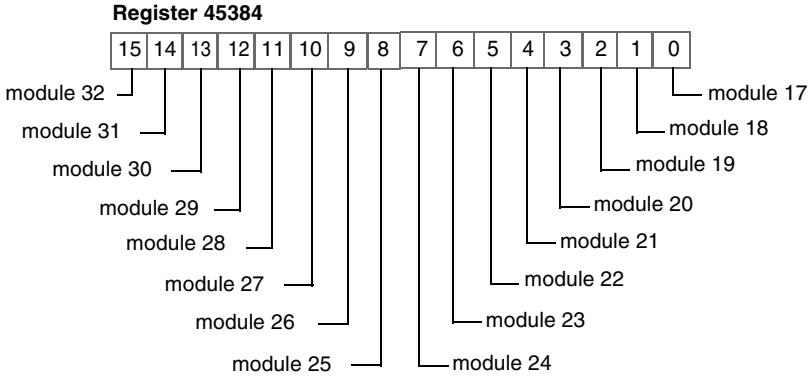
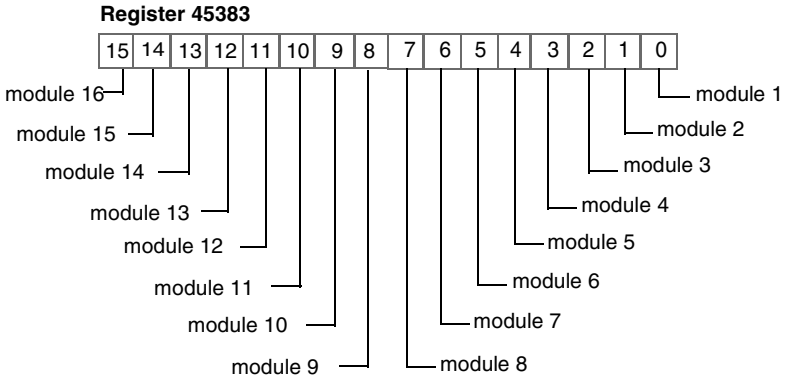

**STB NIP 2212  
Status Register**

Register 45391 contains a word of diagnostic data that is allocated to the status of the STB NIP 2212. The bits in the high byte have predefined meanings that are common to all of the NIMs used with the Advantys STB island. The low byte is reserved for the particular use of each specific NIM:

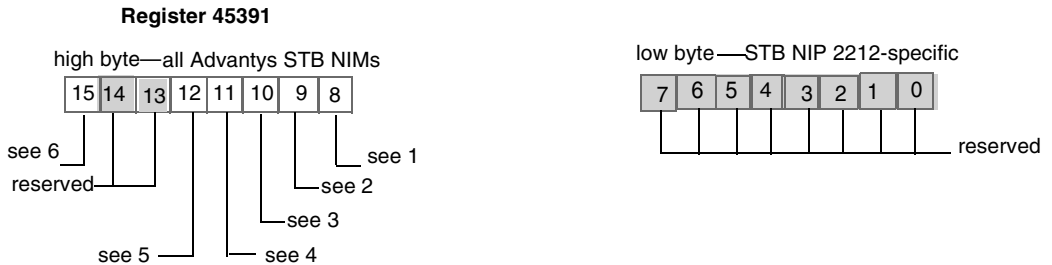

- 1 Module failure—bit 8 is set to 1 if any module on the island bus fails.
- 2 A value of 1 in bit 9 indicates an internal failure—at least one global bit was set.
- 3 A bit value of 1 in bit 10 indicates an external failure—the problem is on the fieldbus.
- 4 A value of 1 in bit 11 indicates that the configuration is protected—the RST button is disabled, and the island configuration requires a password to write to it; a bit value of 0 indicates that the island configuration is unprotected—the RST button is enabled, and the configuration is not password-protected.
- 5 A value of 1 in bit 12 indicates that the configuration on the removable memory card is invalid.
- 6 Island bus output data master—a value of 0 in bit 15 indicates that the fieldbus master device is controlling the output data of the island's process image; a bit value of 1 indicates that the Advantys configuration software is controlling the output data of the island's process image.

---

## Modbus Commands Supported by the STB NIP 2212

---

### Introduction

Modbus is the protocol used by Modicon PLCs. Modbus defines the message structure that the PLCs understand and use, regardless of network type. The Modbus protocol describes the process that a controller uses to access another device, how that device responds, and how errors are detected and reported.

---

### Modbus Message Data Frame

Modbus messages are embedded within the frame or packet structure of the network in use. A Modbus over TCP/IP network uses both the Ethernet II and IEEE 802.3 data formats. For communications with the STB NIP 2212, Modbus messages can be embedded in either frame type. Ethernet II is the default data format.

---

### Modbus Message Structure

The Modbus protocol uses a 16-bit word. A Modbus message begins with a header. A Modbus message uses a Modbus function code (See *List of Supported Commands, p. 134*) as the first byte.

Following is a description of the structure of a Modbus message header:

Invoke Identifier	Protocol Type	Command Length	Destination ID	Modbus Message
two-byte field that associates a request with a response	two-byte field value for Modbus is always 0	two-byte field value is the size of the rest of the message	one-byte	n-byte field first byte is the Modbus function code

---

**List of Supported Commands**

The following table lists the Modbus commands that the STB NIP 2212 supports:

Modbus Function Code	Subfunction or Subindex	Command	Valid Range	Max. No. of Words per Message
3		read holding registers (4x)	1–9999	125
4		read input registers (3x)	1–4697	125
6		write single register (4x)	1–5120 and 9488–9999	1
8	21	get/clear Ethernet statistics (See <i>Ethernet Statistics, p. 135</i> )	0–53	N/A
16		write multiple registers (4x)	1–5120 and 9488–9999	100
22		mask write registers (4x)	1–5120 and 9488–9999	1
23		read/write multiple registers (4x)	1–5120 and 9488–9999	100 (write)
			1–9999 (read)	125 (read)

## Ethernet Statistics

Ethernet statistics comprise status information and errors related to data transmissions to and from the STB NIP 2212 over the Ethernet LAN.

Ethernet statistics are held in a buffer until the **get Ethernet statistics** command is issued, and the statistics are retrieved.

The **clear Ethernet statistics** command clears all of the statistics currently held in the buffer *except the MAC address and the IP address*.

The following table lists the Ethernet statistics used by the Advantys STB system:

Word No. in Buffer	Description	Comment
00–02	MAC address	cannot be cleared
03	board status	
04–05	rx interrupt	
06–07	tx interrupt	
08	jabber failure count	
09	total collisions	
10–11	rx missed packet errors	
12–13	memory errors in state RAM	
14–15	chip restart count	
16–17	framing errors	
18–19	overflow errors	
20–21	CRC errors	
24–25	rx buffer errors	
26–27	tx buffer errors	
28–29	silo underflow	
30–31	late collision	
32–33	lost carrier	
34–35	collision tx failure	
36–37	IP address	cannot be cleared
38–53	reserved	always 0





---

# Connection Example



---

## At a Glance

### Introduction

The information in this chapter provides an example showing how to connect and commission an Advantys STB island with an STB NIP 2212 gateway on a Modbus over TCP/IP (Ethernet) network.

### What's in this Chapter?

This chapter contains the following topics:

Topic	Page
Introduction	138
Network Architecture	139
Sample Configuration	141
Modbus Functions Supported by the STB NIP 2212	145

---

## Introduction

---

### Overview

The connection example that follows describes how to connect and commission an Advantys STB island with an STB NIP 2212 Ethernet gateway module. The connection example does not use a specific Ethernet host because Modbus over TCP/IP is an open protocol.

---

### Assumptions

The connection example is based on the following assumptions:

- You have read the rest of this *Guide*.
  - You have configured your STB NIP 2212 with an IP address that you either know or can locate (See *Summary of Features*, p. 24).
  - You have a basic knowledge of Modbus (See *Modbus Commands Supported by the STB NIP 2212*, p. 133) over TCP/IP.
-

## Network Architecture

### Architectural Diagram

The physical network shown in the following figure is representative of how Advantys STB islands can have various Ethernet hosts and how the islands can be configured as nodes on the Ethernet:

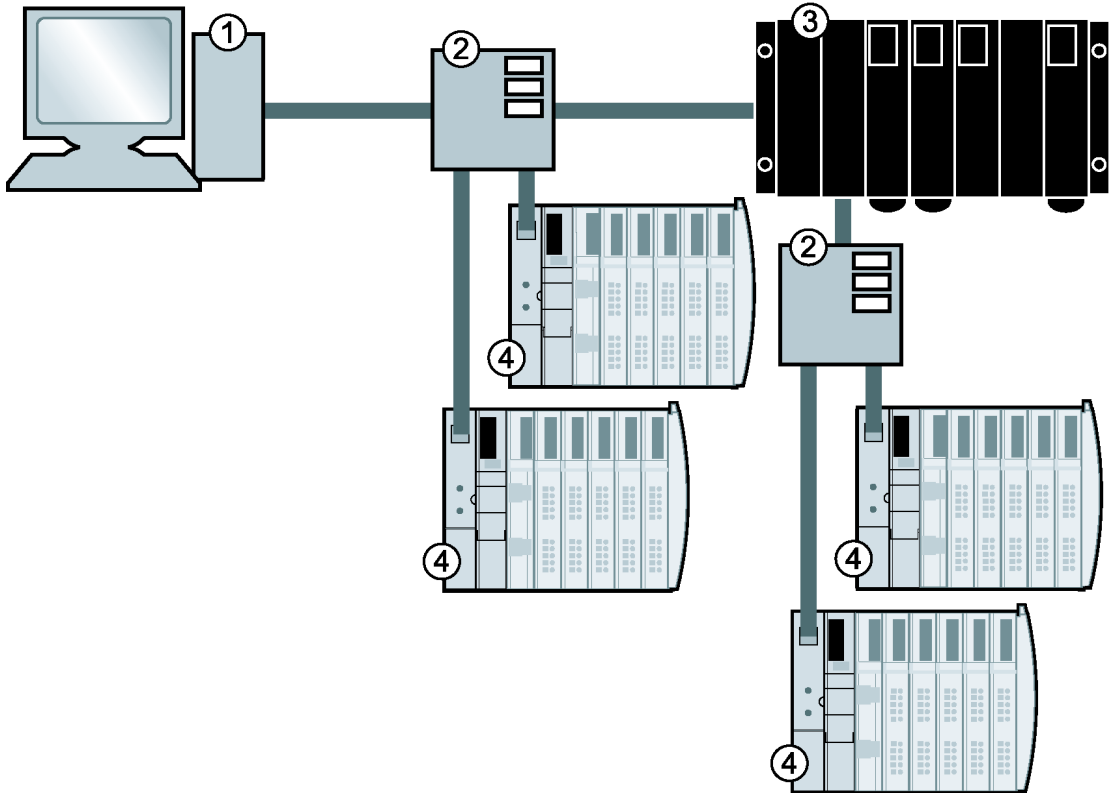

- 1 PC Ethernet host
- 2 switches
- 3 PLC Ethernet host
- 4 Advantys STB islands with STB NIP 2212 gateways

The following table describes the cabling guidelines for the network shown in the figure above:

<b>Type of Connection</b>	<b>Cabling Guidelines</b>
direct connection between a PC host (with an Ethernet card) and the STB NIP 2212	crossover cable
through a switch as <i>recommended by Schneider Electric</i>	shielded (STP) or unshielded (UTP) electrical, twisted pair Category (CAT5) cabling (See <i>STB NIP 2212 Network Interface, p. 26</i> )
<b>Note:</b> Compatible switch, hub, connector, and cable selections are described in the <i>Transparent Factory Network Design and Cabling Guide (490 USE 134 00)</i> .	

---

## Sample Configuration

### Example

A representative island bus assembly with an STB NIP 2212 gateway is shown in the following figure:

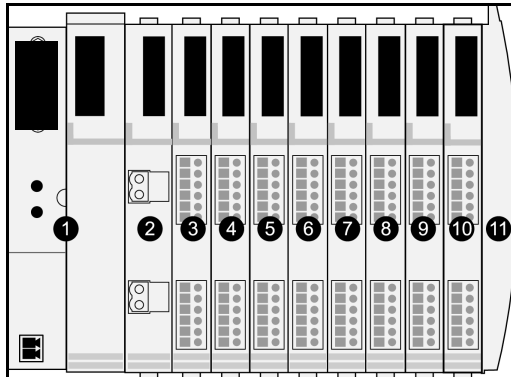

- 1 STB NIP 2212 network interface module
- 2 24 VDC power distribution module
- 3 STB DDI 3230 24 VDC two-channel digital input module (2 bits data, 2 bits status)
- 4 STB DDO 3200 24 VDC two-channel digital output module (2 bits data, 2 bits of echo output data, 2 bits status)
- 5 STB DDI 3420 24 VDC four-channel digital input module (4 bits data, 4 bits status)
- 6 STB DDO 3410 24 VDC four-channel digital output module (4 bits data, 4 bits of echo output data, 4 bits status)
- 7 STB DDI 3610 24 VDC six-channel digital input module (6 bits data, 6 bits status)
- 8 STB DDO 3600 24 VDC six-channel digital output module (6 bits data, 6 bits of echo output data, 6 bits status)
- 9 STB AVI 1270 +/-10 VDC two-channel analog input module (16 bits data—channel 1, 16 bits data—channel 2, 8 bits status—channel 1, 8 bits status—channel 2)
- 10 STB AVO 1250 +/-10 VDC two-channel analog output module (16 bits data—channel 1, 16 bits data—channel 2, 8 bits status—channel 1, 8 bits status—channel 2)
- 11 STB XMP 1100 island bus termination plate

The I/O modules in the sample assembly have the following island bus addresses:

I/O Model	Module Type	Module's Island Bus Address	Module's Island Bus Address
STB DDI 3230	two-channel digital input	1	N1
STB DDO 3200	two-channel digital output	2	N2
STB DDI 3420	four-channel digital input	3	N3
STB DDO 3410	four-channel digital output	4	N4
STB DDI 3610	six-channel digital input	5	N5
STB DDO 3600	six-channel digital output	6	N6
STB AVI 1270	two-channel analog input	7	N7
STB AVO 1250	two-channel analog output	8	N8

The PDM and the termination plate are not addressable (See *Addressable Modules, p. 46*).

**Modbus over TCP/IP View of the Sample Island Configuration**

The order in which the Advantys STB I/O modules in the sample island (See *Example, p. 141*) are physically assembled determines the order in which data will appear in the input and output data image areas (See *The Island's Process Image Blocks, p. 169*) of the process image.

- input data includes all of the I/O modules on an Advantys STB island bus that contain status, data, and/or echo output data
- output data contains only data

*No bit-packing is used.*

Standard Modbus 4x and 3x message formats are the addressing mechanism.

**Input Process Image**

The I/O modules in the sample island (See *Example, p. 141*) require 18 Modbus registers in the input data image area (See *The Input Data and I/O Status Process Image, p. 120*). The following table shows how these registers are organized:

Modbus Register	15	14	13	12	11	10	9	8	7	6	5	4	3	2	1	0
45392	empty—set to 0														N1 data	
	STB DDI 3230 data															
45393	empty—set to 0														N1 status	
	STB DDI 3230 status															
45394	empty—set to 0														N2 echo	
	STB DDO 3200 feedback															
45395	empty—set to 0														N2 status	
	STB DDO 3200 status															

Modbus Register	15	14	13	12	11	10	9	8	7	6	5	4	3	2	1	0
45396	empty—set to 0												N3 data			
	STB DDI 3420 data															
45397	empty—set to 0												N3 status			
	STB DDI 3420 status															
45398													N4 echo			
	STB DDO 3410 feedback															
45399													N4 status			
	STB DDO 3410 status															
45400											N5 data					
	STB DDI 3610 data															
45401											N5 status					
	STB DDI 3610 status															
45402											N6 echo					
	STB DDI 3600 feedback															
45403											N6 status					
	STB DDI 3600 status															
45404	N7channel 1 data															
	AVI 1270 channel 1data															
45405											N7 channel 1 status					
	AVI 1270 channel 1 status															
45406	N7channel 2 data															
	AVI 1270 channel 2 data															
45407											N7 channel 2 status					
	AVI 1270 channel 2 status															
45408											N8 channel 1 status					
	AVI 1250 channel 1 status															
45409											N8 channel 2 status					
	AVI 1250 channel 2 status															

**Output Process Image**

The I/O modules in the sample island bus assembly require five Modbus registers in the output data image area (See *The Output Data Process Image*, p. 119). The following table shows how these registers are organized:

Modbus Register	15	14	13	12	11	10	9	8	7	6	5	4	3	2	1	0
40001	empty—set to 0														N2 data	
	STB DDI 3230 data															
40002	empty—set to 0												N4 data			
	STB DDO 3420 data															
40003	empty—set to 0										N6 data					
	STB DDO 3600 data															
40004	N8 channel 1 data															
	STB AVO 1250, channel 1 data															
40005	N8 channel 2 data															
	STB AVO 1250, channel 2 data															



## Modbus Functions Supported by the STB NIP 2212

---

**Introduction** The STB NIP 2212 supports the Modbus functionality that is described below.

**Note:** The procedures required by your specific Modbus master and Modbus over TCP/IP application may differ from those described here. Be sure to read the documentation specific to your Modbus master and/or application.

### **Operations Summary**

A Modbus over TCP/IP fieldbus master can read and write to the Modbus registers in the STB NIP 2212. Communications from the Modbus master to the STB NIP 2212 include:

- Modbus function code
  - the size of the data being transmitted in words
  - number of first Modbus register to be used
-

**Request and Response Example**

The following example uses the data from channel 1 and channel 2 in the STB AVO 1250 module (node 8 in the sample Advantys STB island bus) (See *Example, p. 141*). In the example, Modbus register 40004 corresponds to channel 1 and Modbus register 40005 corresponds to channel 2.

**Note:** The examples use hexadecimal notation (0x000) for their numerical format. Addressing begins in the output process image at register 40001. The format and addressing may vary according to your particular software and controls.

**Request:** The request determines the starting address and the number of registers to be read. In this case, two registers—40004 and 40005—should be read:

Description	Field	Example
command	Modbus function code	0x003
register count	word count	0x002
starting point	starting register	0x40004

**Response:** The response is the reply from the device. It contains the contents of the registers in which the requested data is located. In this case, register 40004 contains data 1234, and register 40005 contains data 6789:

Description	Field	Example
command	Modbus function code	0x003
register count	word count	0x002
returned value	value of register 40004	0x1234
returned value	value of register 40005	0x6789

**Reference Descriptions**

The x's following the leading character (3/4) represent a four-digit Modbus register address:

- 3xxx  
Read input registers. A 3x reference register contains a 16-bit number received from an external source, e.g., an analog signal.
  - 4xxx  
Read/write output or holding registers. A 4x reference register is used to store 16-bits of numerical data (binary or decimal), or to send the data from the CPU to an output channel.
-

### List of Supported Function Codes and Their Descriptions

The following table lists the function codes that can be used by Modbus over TCP/IP masters that communicate with the STB NIP 2212:

Modbus Function Code	Subfunction or Subindex	Hexadecimal	Description
3		0x03	read output holding registers (4x)
4		0x04	read input registers (3x)
6		0x06	write single register (4x)
8	sub index 21	0x08	get/clear Ethernet statistics (See <i>Ethernet Statistics</i> , p. 135)
16		0x10	write multiple (output) registers (4x)
22		0x16	mask write registers (4x)
23		0x17	read/write multiple registers (4x)

### Modbus over TCP/IP Data Exchange

The following table describes the *general* process used by Modbus over TCP/IP masters to exchange data with the STB NIP 2212.

Stage	Action
1	Execute a function, specify the function code and the register address of the selected input or output channel.
2	The Modbus master (i.e., PC, PLC) sends a request to the STB NIP 2212. <ul style="list-style-type: none"> <li>● If no exception is returned, the STB NIP 2212 responds to the master by sending the data that was requested.</li> <li>● If a request contains an error, the STB NIP 2212 returns an exception code to the master.</li> </ul>

### List of Exception Codes

The following table describes the exception codes that Modbus over TCP/IP uses to indicate an error condition:

Code in Hexadecimal	Description
0x01	illegal function
0x02	illegal data address
0x03	illegal data value
0x04	slave device failure



---

# Advanced Configuration Features



# 8

---

## At a Glance

### Introduction

This chapter describes the advanced and/or optional configuration features that you can add to an Advantys STB island.

### What's in this Chapter?

This chapter contains the following topics:

Topic	Page
STB NIP 2212 Configurable Parameters	150
Configuring Mandatory Modules	154
Prioritizing a Module	156
What Is a Reflex Action?	157
Island Fallback Scenarios	162
Saving Configuration Data	164
Protecting Configuration Data	165
A Modbus View of the Island's Data Image	166
The Island's Process Image Blocks	169
The HMI Blocks in the Island Data Image	172

---

## STB NIP 2212 Configurable Parameters

### Introduction

The following information describes how to the configure parameters for the STB NIP 2212 using the Advantys configuration software.

The following operating parameters are user configurable:

- data size (in words) of PLC output data transmitted to the HMI panel and HMI input data sent to the PLC
- maximum node ID for the last module assembled on the island bus, including CANopen devices

### General Information

For general information about the NIM module (model name, version number, vendor code, etc.), do the following:

Step	Action	Comment
1	Open your island configuration with the Advantys configuration software.	The STB NIP 2212 is the leftmost module in your island bus assembly.
2	Double-click on the NIM in the island editor.	The <i>module editor</i> window appears.
3	Select the <i>General</i> tab.	General information about the STB NIP 2212 is available from this tab.

### Accessing Configurable Parameters

To access the configurable parameters for the STB NIP 2212:

Step	Action	Comment
1	Double-click on the STB NIP 2212 in the island editor.	The <i>module editor</i> window appears.
2	Select the <i>Parameters</i> tab.	Configurable parameters are located under this tab.
3	In the <i>Parameter name</i> column, expand the <i>Additional Info Store List</i> by clicking on the plus (+) sign.	The configurable parameters are displayed.

### Selecting the Display Format

By default, the values for the configurable NIM parameters use decimal notation. You can change the display format to hexadecimal notation, and vice-versa:

Step	Action	Comment
1	Double-click the NIM in the island editor.	The <i>module editor</i> window appears.
2	Select the <i>Parameters</i> tab.	
3	Click on the checkbox in front of <i>Hexadecimal</i> at the top right of the module editor window. Note: To use decimal notation, again, click on this checkbox to disable hexadecimal notation.	The values for the configurable parameters will display in hexadecimal notation.

### Reserved Sizes (HMI to PLC)

The network interprets data from the HMI as input and reads it from the input data table in the process image. This table is shared with data from all input modules on the island bus. When the reserved size (HMI to PLC) is selected, the range of available data sizes (in words) is displayed. Space that you reserve for HMI to PLC data must not exceed the maximum value shown (512 words).

### Reserved Sizes (PLC to HMI)

The network transmits data to the HMI as output by writing it to the output data table in the process image. This table is shared with data for all output modules on the island bus. When the reserved size (PLC to HMI) is selected, the range of available data sizes (in words) is displayed. Space that you reserve for the PLC to HMI data must not exceed the maximum value shown (512 words).

**Reserving Data Sizes**

To transfer data to the PLC from a Modbus HMI panel attached to the CFG port, you must reserve space for that data. To reserve data sizes:

Step	Action	Result
1	In the <i>module editor</i> window, select the <i>Parameters</i> tab.	
2	In the <i>Parameter name</i> column, expand the <i>Additional Info Store List</i> by clicking on the plus (+) sign.	The configurable NIM parameters are displayed.
3	Double-click in the <i>Value</i> column next to the <i>Reserved Size (Words) of HMI to PLC table</i> .	The value is highlighted.
4	Type a value for the data size to be reserved for data sent from the HMI panel to the PLC.	The value <i>plus</i> the data size of your island cannot exceed the maximum value. If you accept the default value (0), no space will be reserved in the HMI table in the process image.
5	Repeat steps 2-4 to select a value for the <i>Reserved Size (Words) of PLC to HMI table</i> row.	
6	Click on the <i>OK</i> button to save your work.	
7	Click on the <i>Apply</i> button to configure the NIM with these values.	

**CANopen Device Node IDs**

From the Parameters tab, you can set the maximum node ID of the last module on the island bus. The last module may be a standard CANopen device. Standard CANopen devices follow the last segment of STB I/O modules. CANopen modules are addressed by counting backwards from the value that you specify here. The ideal node ID sequence is sequential.

For example, if you have an island with five STB I/O modules and three CANopen devices, a maximum node ID of at least 8 (5 + 3) is required. This will result in node IDs of 1 through 5 for STB I/O modules and 6 through 8 for standard CANopen devices. Using the default ID of 32 (the maximum number of modules the island can support) will result in node IDs of 1 through 5 for STB I/O modules and 30 through 32 for standard CANopen devices. Unless required, high addresses are not desirable if any of your standard CANopen devices has a limited address range.



**Assigning the  
Max. Node ID  
(CANopen  
Devices)**

To assign the highest node ID used by a CANopen device on the island bus:

Step	Action	Comment
1	In the <i>module editor</i> window, select the <i>Parameters</i> tab.	Configurable parameters are located under this tab.
2	In the box next to <i>Max. node ID on the CANopen extension</i> , enter a node ID.	This node ID represents the last CANopen module on the island bus.

## Configuring Mandatory Modules

---

### Summary

As part of a custom configuration, you can assign *mandatory* status to any I/O module or preferred device on an island. The mandatory designation indicates that you consider the module or device critical to your application. If the NIM does not detect a healthy mandatory module at its assigned address during normal operations, the NIM stops the entire island.

**Note:** The Advantys configuration software is required to designate an I/O module or a preferred device as a mandatory module.

---

### Specifying Mandatory Modules

By default, the Advantys STB I/O modules are in a non-mandatory (*standard*) state. Mandatory status is enabled by clicking on the mandatory checkbox on a module or preferred device's parameters property sheet. Depending on your application, any number of modules that your island will support can be designated as mandatory modules.

---

### Effects on Island Bus Operations

The following table describes the conditions under which mandatory modules affect island bus operations and the NIM's response:

Condition	Response
A mandatory module fails during normal island bus operations.	The NIM stops the island bus. The island enters fallback mode (See <i>Island Fallback Scenarios</i> , p. 162). I/O modules and preferred devices assume their fallback values.
You attempt to hot swap a mandatory module.	The NIM stops the island bus. The island enters fallback mode. I/O modules and preferred devices assume their fallback values.
You are hot swapping a standard I/O module that resides to the left of a mandatory module on the island bus, and the island loses power.	When power is restored, the NIM attempts to address the island modules but must stop at the empty slot where the standard module used to reside. Because the NIM is now unable to address the mandatory module, it generates a mandatory mismatch error and the island fails to restart.

---

## Recovering from a Mandatory Stop

Pushing the RST button (See *The RST Button*, p. 55) while recovering from a mandatory stop will load the island's default configuration data.

	<b>WARNING</b>
	<p><b>UNINTENDED EQUIPMENT OPERATION/LOSS OF CONFIGURATION—RST BUTTON WHILE RECOVERING FROM MANDATORY STOP</b></p> <p>Pushing the RST button (See <i>The RST Button</i>, p. 55) causes the island bus to reconfigure itself with factory-default operating parameters, which do not support mandatory I/O status.</p> <ul style="list-style-type: none"> <li>● Do not attempt to restart the island by pushing the RST button.</li> <li>● If a module is unhealthy, replace it with the same module type.</li> </ul> <p><b>Failure to follow this precaution can result in death, serious injury, or equipment damage.</b></p>

If the NIM has stopped island bus operations because it cannot detect a healthy mandatory module, you can recover island bus operations by installing a healthy module of the same type. The NIM automatically configures the replacement module to match the removed module. Assuming that other modules and devices on the island bus are correctly configured and conform to their configuration data as written to Flash memory, the NIM will start/restart normal island bus operations.

## Prioritizing a Module

---

### Summary

Using the Advantys configuration software, you can assign priority to digital input modules in your island assembly. Prioritization is a method of fine tuning the NIM's I/O scan of the island bus. The NIM will scan modules with priority more frequently than other island modules.

---

### Limitations

You can prioritize digital input modules only. You cannot prioritize digital output modules or analog modules of any kind. You can prioritize only 10 digital input modules for a given island.

---

## What Is a Reflex Action?

### Summary

Reflex actions are small routines that perform dedicated logical functions directly on the Advantys island bus. They allow output modules on the island to act on data and drive field actuators directly, without requiring the intervention of the fieldbus master. A typical reflex action comprises one or two function blocks that perform:

- Boolean AND or exclusive-OR operations
- comparisons of an analog input value to user-specified threshold values
- up- or down-counter operations
- timer operations
- the triggering of a latch to hold a digital value high or low
- the triggering of a latch to hold an analog value at a specific value

The island bus optimizes reflex response time by assigning the highest transmission priority to its reflex actions. Reflex actions take some of the processing workload off the fieldbus master, and they offer a faster, more efficient use of system bandwidth.

### How Reflex Actions Behave

Reflex actions are designed to control outputs independently of the fieldbus master controller. They may continue to turn outputs on and off even when power is removed from the fieldbus master. Use prudent design practices when you use reflex actions in your application.

	<b>WARNING</b>
	<p><b>UNEXPECTED OUTPUT OPERATION.</b></p> <p>For outputs that are configured to respond to reflex actions, the output state represented in the island's network interface module (NIM) may not represent the actual states of the outputs.</p> <ul style="list-style-type: none"> <li>● Turn off field power before you service any equipment connected to the island.</li> <li>● For digital outputs, view the echo register for the module in the process image to see the actual output state.</li> <li>● For analog outputs, there is no echo register in the process image. To view an actual analog output value, connect the analog output channel to an analog input channel.</li> </ul> <p><b>Failure to follow this precaution can result in death, serious injury, or equipment damage.</b></p>

## Configuring a Reflex Action

Each block in a reflex action must be configured using the Advantys configuration software.

Each block must be assigned a set of inputs and a result. Some blocks also require that you specify one or more user-preset values—a compare block, for example, requires that you preset threshold values and a delta value for hysteresis.

## Inputs to a Reflex Action

The inputs to a reflex block include an enable input and one or more operational inputs. The inputs may be constants or they may come from other I/O modules on the island, from virtual modules or outputs from another reflex block. For example, an XOR block requires three inputs—the enable and two digital inputs that contain the Boolean values to be XORed:

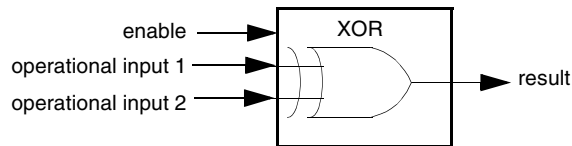

Some blocks, such as the timers, require reset and/or trigger inputs to control the reflex action. The following example shows a timer block with three inputs:

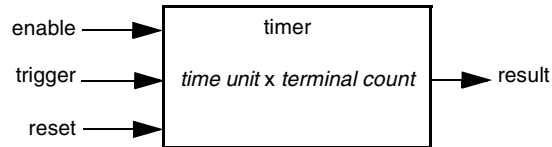

The trigger input starts the timer at 0 and accumulates *time units* of 1, 10, 100 or 1000 ms for a specified number of counts. The reset input causes the timer accumulator to be reset.

An input to a block may be a Boolean value, a word value, or a constant, depending on the type of reflex action it is performing. The enable input is either a Boolean or a constant *always enabled* value. The operational input to an block such as a digital latch must always be a Boolean, whereas the operational input to an analog latch must always be a 16-bit word.

You will need to configure a source for the block's input values. An input value may come from an I/O module on the island or from the fieldbus master via a virtual module in the NIM.

**Note:** All inputs to a reflex block are sent on a change-of-state basis. After a change-of-state event has occurred, the system imposes a 10 ms delay before it accepts another change of state (input update). This feature is provided to minimize jitter in the system.

**Result of a Reflex Block**

Depending on the type of reflex block that you use, it will output either a Boolean or a word as its result. Generally, the result is mapped to an *action module*, as shown in the following table:

Reflex Action	Result	Action Module Type
Boolean logic	Boolean value	digital output
integer compare	Boolean value	digital output
counter	16-bit word	first block in a nested reflex action
timer	Boolean value	digital output
digital latch	Boolean value	digital output
analog latch	16-bit word	analog output

The result from a block is usually mapped to an individual channel on an output module. Depending on the type of result that the block produces, this action module may be an analog channel or a digital channel.

When the result is mapped to a digital or analog output channel, that channel becomes dedicated to the reflex action and can no longer use data from the fieldbus master to update its field device.

The exception is when a reflex block is the first of two actions in a nested reflex action.

## Nesting

The Advantys configuration software allows you to create nested reflex actions. One level of nesting is supported—i.e., two reflex blocks, where the result of the first block is an operational input to the second block.

When you nest a pair of blocks, you need to map the results of both to the same action module. Choose the action module type that is appropriate for the result of the second block. This may mean that in some cases you will need to choose an action module for the first result that does not seem to be appropriate according to the table above.

For example, say you want to combine a counter block and a compare block in a nested reflex action. You want the result of the counter to be the operational input to the compare block. The compare block will then produce a Boolean as its result:

### first nested action

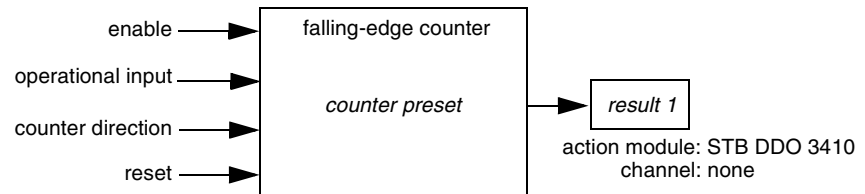

### second nested action

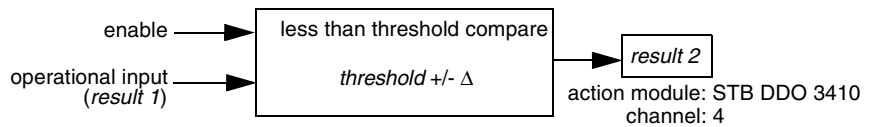

*Result 2* (from the compare block) is the result that the nested reflex action will send to an actual output. Because the result of a compare block needs to be mapped to a digital action module, *result 2* is mapped to channel 4 on an STB DDO 3410 digital output module.

*Result 1* is used only inside the module—it provides the 16-bit operational input to the compare block. It is mapped to the same STB DDO 3410 digital output module that is the action module for the compare block.

Instead of specifying a physical channel on the action module for *result 1*, the channel is set to *none*. In effect, you are sending *result 1* to an internal reflex buffer where it is stored temporarily until it is used as the operational input to the second block. You are not really sending an analog value to a digital output channel.



**Number of Reflex  
Blocks on an  
Island**

An island can support up to 10 reflex blocks. A nested reflex action consumes two blocks.

An individual output module can support up to two reflex blocks. Supporting more than one block requires that you manage your processing resources efficiently. If you are not careful with your resources, you may be able to support only one block on an action module.

Processing resources are consumed quickly when a reflex block receives its inputs from multiple sources (different I/O modules on the island and/or virtual modules in the NIM). The best way to preserve processing resources is to:

- use the *always enabled* constant as the enable input whenever possible
  - use the same module to send multiple inputs to a block whenever possible
-

## Island Fallback Scenarios

---

### Introduction

In the event of a communications failure on the island or between the island and the fieldbus, output data is put into a *safe* fallback state. In this state, output data is replaced with pre-configured fallback values, ensuring that a module's output data values are known when the system recovers from a communications failure.

---

### Fallback Scenarios

There are several scenarios in which Advantys STB output modules go into their fallback states:

- loss of fieldbus communications—Communications with the PLC are lost.
- loss of island bus communications—There is an internal island bus communications error, indicated by a missing heartbeat message from either the NIM or a module.
- change of operating state—The NIM may command the island I/O modules to switch from a running to a non-running (stopped or reset) state.
- missing or failed mandatory module (See *Configuring Mandatory Modules*, p. 154)—The NIM detects the absence or failure of a mandatory island module.

**Note:** If a mandatory (or any other) module fails, it needs to be replaced. The module itself does not go into its fallback state.

In all of these fallback scenarios, the NIM disables the heartbeat message.

---

### Heartbeat Message

The Advantys STB system relies on a heartbeat message to ensure the integrity and continuity of communications between the NIM and the island modules. The health of island modules and the overall integrity of the Advantys STB system are monitored through the transmission and reception of these periodic island bus messages.

Because island I/O modules are configured to monitor the NIM's heartbeat message, output modules will go into their fallback states if they do not receive a heartbeat message from the NIM within the defined interval.

---

### Fallback States for Reflex Functions

Only an output module channel to which the result of a reflex action (See *What Is a Reflex Action?*, p. 157) has been mapped can operate in the absence of the NIM's heartbeat message.

When modules that provide input for reflex functionality fail or are removed from the island, the channels that hold the result of those reflex actions go into their fallback states.

In most cases, an output module that has one of its channels dedicated to a reflex action will go to its configured fallback state if the module loses communication with the fieldbus master. The only exception is a two-channel digital output module that has both of its channels dedicated to reflex actions. In this case, the module may continue to solve logic after a loss of fieldbus communication. For more information about reflex actions, refer to the *Reflex Actions Reference Guide* (890 USE 183).

### Configured Fallback

To define a customized fallback strategy for individual modules, you are required to use the Advantys configuration software. Configuration is done channel by channel. You can configure a single module's multiple channels with different fallback parameters. Configured fallback parameters—implemented only during a communications failure—are part of the configuration file stored in the NIM's non-volatile Flash memory.

### Fallback Parameters

You can select either of two fallback modes when configuring output channels with the Advantys configuration software:

- *hold last value*—In this mode, outputs retain the last values they were assigned before the failure.
- *predefined value*—In this (default) mode, you can select either of two fallback values:
  - 0 (default)
  - some value in acceptable range

The permissible values for fallback parameters in the *predefined value* mode for discrete and analog modules and reflex functions appear in the following table:

Module Type	Fallback Parameter Values
discrete	0/off (default)
	1/on
analog	0 (default)
	not 0 (in range of acceptable analog values)

**Note:** In an auto-configured system, default fallback parameters and values are always used.

## Saving Configuration Data

---

### Introduction

The Advantys configuration software allows you to save configuration data created or modified with this software to the NIM's Flash memory and/or to the removable memory card (See *Physical Description*, p. 50). Subsequently, this data can be read from Flash memory and used to configure your physical island.

**Note:** If your configuration data is too large, you will receive a warning message when you attempt to save it.

### How to Save a Configuration

The following procedure describes the general steps to use to save a configuration data file to either Flash memory directly or to a removable memory card. For more detailed procedural information, use the configuration software's online help feature:

Step	Action
1	Connect the device running the Advantys configuration software to the CFG port (See <i>The CFG Interface</i> , p. 33) on the NIM, and launch the software.
2	Download the configuration data that you want to save from the configuration software to the NIM. Then, use one of the following commands from the configuration software's Online menu: <ul style="list-style-type: none"><li>● To save to the NIM's Flash memory, use the <b>store to Flash</b> command.</li><li>● To save to a removable memory card, first install the card (See <i>Installing the Card</i>, p. 51) in the host NIM, then use the <b>store to removable memory card</b> command.</li></ul>

---

## Protecting Configuration Data

---

### Introduction

As part of a custom configuration, you can password-protect an Advantys STB island. This protection restricts write privileges to authorized personnel and prevents unauthorized users from overwriting the configuration data currently stored in Flash memory.

You must use the Advantys configuration software to password-protect an island's configuration.

---

### Protection Feature

If a configuration is protected, access to it is restricted in the following ways:

- An unauthorized user is unable to overwrite the current configuration data in Flash memory.
- The presence of a removable memory card (See *Installing the STB XMP 4440 Optional Removable Memory Card*, p. 50) is ignored. The configuration data currently stored in Flash cannot be overwritten by data on the card.
- The RST button (See *The RST Button*, p. 55) is disabled, and pushing it has no effect on island bus operations.

The island runs normally when it is in protected mode. All users have the ability to monitor (read) the activity on the island bus.

---

### Password Characteristics

A password must meet the following criteria:

- It must be between 0 and 6 characters in length.
- Only alphanumeric ASCII characters are permitted.
- The password is case-sensitive.

If password protection is enabled, your password is saved to Flash memory (or to a removable memory card) when you save the configuration data.

**Note:** A protected configuration is inaccessible to anyone who does not know the password. Your system administrator is responsible for keeping track of the password and the list of authorized users. If the assigned password is lost or forgotten, you will be unable to change the island's configuration. If the password is lost and you need to reconfigure the island, you will need to perform a destructive reflash of the NIM. This procedure is described on the Advantys STB product Web site at [www.schneiderautomation.com](http://www.schneiderautomation.com).

---

## A Modbus View of the Island's Data Image

---

### Summary

A block of Modbus registers is reserved in the NIM to hold and maintain the island's data image. Overall, the data image holds 9999 registers. The registers are divided into nine contiguous groups (or blocks), each dedicated to a specific purpose.

---

### Modbus Registers and Their Bit Structure

Registers are 16-bit constructs. The most significant bit (MSB) is bit 15, which is displayed as the leftmost bit in the register. The least significant bit (LSB) is bit 0, displayed as the rightmost bit in the register:

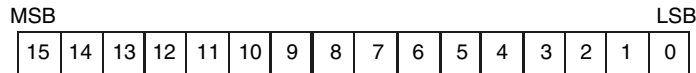

The bits can be used to display operating data or device/system status. Each register has a unique reference number, starting at 40001. The content of each register, represented by its 0/1 bit pattern, may be dynamic, but the register reference and its assignment in the control logic program remain constant.

---

**The Data Image**

The 9999 contiguous registers in the Modbus data image start at register 40001. The illustration below shows a graphical representation of the data image and how it is subdivided into nine distinct blocks:

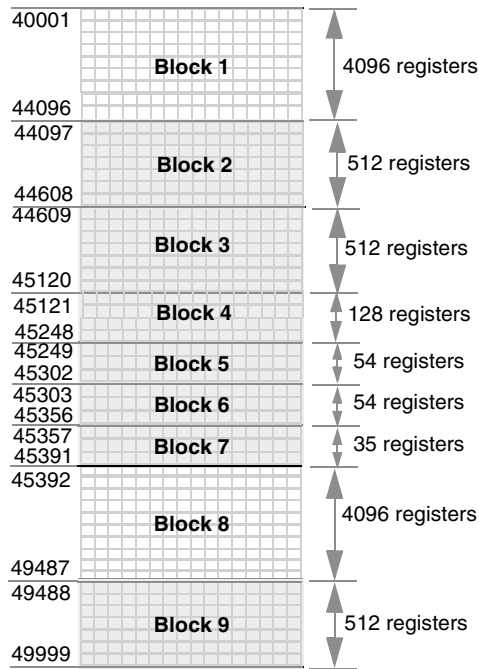

**Block 1** output data process image (4096 registers available)

**Block 2** fieldbus master-to-HMI output table (512 registers available)

**Block 3** reserved (512 registers)

**Block 4** 128-register block reserved for future read/write use

**Block 5** 54-register block reserved for future read/write use

**Block 6** 54-register block reserved for future read-only use

**Block 7** 35 predefined island bus status registers

**Block 8** input data/status process image (4096 registers available)

**Block 9** HMI-to-fieldbus master input table (512 registers available)

Each block has a fixed number of registers reserved for its use. Whether or not all the registers reserved for that block are used in an application, the number of registers allocated to that block remains constant. This permits you to know at all times where to begin looking for the type of data of interest to you.

For example, to monitor the status of the I/O modules in the process image, look at the data in block 8 beginning at register 45392.

**Reading Register Data** All the registers in the data image can be read by an HMI panel connected to the island at the NIM's CFG port (See *The CFG Interface*, p. 33). The Advantys configuration software reads all this data, and displays blocks 1, 2, 8 and 9 in the Modbus Image screen in its I/O Image Overview.

---

**Writing Register Data** Some registers, usually some configured number of registers in block 9 (registers 49488 through 49999) of the data image, may be written to by an HMI panel (See *HMI Panel Configuration*, p. 172). The Advantys configuration software may also be used to write data to the registers in block 1 (registers 40001 through 44096). The configuration software must be the island bus master in order for it to write to the data image—i.e., the island must be in *test* mode.

---



## The Island's Process Image Blocks

---

### Summary

Two blocks of registers in the island's data image (See *The Data Image*, p. 167) are the focus for this discussion. The first block is the output data process image, which starts at register 40001 and goes to register 44096. The other block is the input data and I/O status process image, which also consumes 4096 registers (45392 through 49487). The registers in each block are used to report island bus device status and to dynamically exchange input or output data between the fieldbus master and the island's I/O modules.

---

## Output Data Process Image

The output data block (registers 40001 through 44096) handles the output data process image. This process image is a Modbus representation of the control data that has just been written from the fieldbus master to the NIM. Only data for the island's output modules is written to this block.

Output data is organized in 16-bit register format. One or more registers are dedicated to the data for each output module on the island bus.

For example, say you are using a two-channel digital output module as the first output module on your island bus. Output 1 is on and output 2 is off. This information would be reported in the first register in the output data process image, and it would look like this:

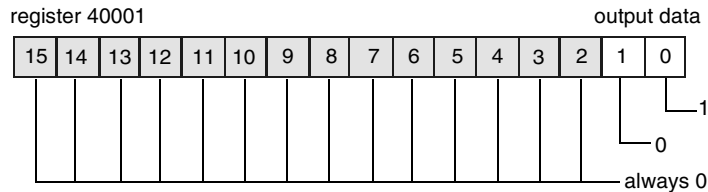

where:

- Normally, a value of 1 in bit 0 indicates that output 1 is on.
- Normally, a value of 0 in bit 1 indicates that output 2 is off.
- The remaining bits in the register are not used.

Some output modules, such as the one in the example above, utilize a single data register. Others may require multiple registers. An analog output module, for example, would use separate registers to represent the values for each channel, and might use the 11 or 12 most significant bits to display analog values in IEC format.

Registers are allocated to output modules in the output data block according to their addresses on the island bus. Register 40001 always contains the data for the first output module on the island—the output module closest to the NIM.

**Note:** The requirements of each output module in the Advantys STB family are described in the *Advantys STB Hardware Components Reference Guide* (890 USE 172).

A detailed view of how the registers are implemented in the output data block is shown in the process image example.

**Output Data  
Read/Write  
Capabilities**

The registers in the output data process image are read/write-capable.

You can read (i.e., monitor) the process image using an HMI panel or the Advantys configuration software. The data content that you see when you monitor the output data image registers is updated in near-real time.

The island's fieldbus master also writes updated control data to the output data process image.

---

**Input Data and I/  
O Status Process  
Image**

The input data and I/O status block (registers 45392 through 49487) handles the input data and I/O status process image. Every I/O module on the island bus has information that needs to be stored in this block.

- Each digital input module reports data (the on/off status of its input channels) in one register of input data and I/O status block, then reports its status (e.g., the presence or absence of errors) in the next register.
- Each analog input module uses four registers in the input data and I/O status block. It represents the analog data for each channel in separate registers and the status of each channel in separate registers. Analog data is usually represented with 11- or 12-bit resolution in the IEC format; status in an analog input channel is usually represented by a series of status bits that report the presence or absence of an out-of-range value in a channel.
- Each digital output module reports an echo of its output data to a register in the input data and I/O status block. Echo output data registers are essentially copies of the register values that appear in the output data process image. This data is usually not of much interest, but it can be useful in the event that a digital output channel has been configured for a reflex action. In this case, the fieldbus master can see the bit value in the echo output data register even though the output channel is being updated inside the island bus.
- Each analog output module uses two registers in the input data and I/O status block to report status. Status in an analog output channel is usually represented by a series of status bits that report the presence or absence of an out-of-range value in a channel. Analog output modules do not report data in this block.

A detailed view of how the registers in the input data and I/O status block are implemented is shown in the process image example.

---

## The HMI Blocks in the Island Data Image

---

### Summary

An HMI panel that communicates using the Modbus protocol can be connected to the CFG port (See *The CFG Interface*, p. 33) on the NIM. Using the Advantys configuration software, you can reserve one or two blocks of registers in the data image (See *A Modbus View of the Island's Data Image*, p. 166) to support HMI data exchange. When an HMI panel writes to one of these blocks, that data is accessible to the fieldbus master (as inputs). Data written by the fieldbus master (as outputs) is stored in a different reserved block of registers that the HMI panel can read.

---

### HMI Panel Configuration

Advantys STB supports the ability of an HMI panel to act as:

- an input device, which writes data to the island's data image that is read by the fieldbus master
  - an output device, which can read data written by the fieldbus master to the island's data image
  - a combined I/O device
- 

### HMI Input Data Exchange

Input data to the fieldbus master can be generated by the HMI panel. Input controls on an HMI panel might be elements such as:

- push buttons
- switches
- a data entry keypad

To use an HMI panel as an input device on the island, you need to enable the HMI-to-fieldbus master block in the island's data image (See *The Data Image*, p. 167) and specify the number of registers in this block that you want to use for HMI-to-fieldbus master data transfers. You must use the Advantys configuration software to make these configuration adjustments.

The HMI-to-fieldbus master block can comprise up to 512 registers, ranging from register 49488 to 49999. (Your actual register limit will be dictated by your fieldbus.) This block follows immediately after the standard input data and I/O status process image (See *Input Data and I/O Status Process Image*, p. 171) block (registers 45392 through 49487) in the island's data image.

The HMI panel writes the input data to a specified number of registers in the HMI-to-fieldbus master block. The NIM manages the transfer of the HMI data in these registers as part of the overall input data transfer—it converts the 16-bit register data to a fieldbus-specific data format and transfers it together with the standard input data and I/O status process image to the fieldbus. The fieldbus master sees and responds to HMI data as if it were standard input data.

---

**HMI Output Data Exchange**

In turn, output data written by the fieldbus master can be used to update enunciator elements on the HMI panel. Enunciator elements might be:

- display indicators
- buttons or screen images that change color or shape
- data display screens (for example, temperature read-outs)

To use the HMI panel as an output device, you need to enable the fieldbus-to-HMI block in the island's data image (See *The Data Image*, p. 167) and specify the number of registers in this block that you want to use. You need to use the Advantys configuration software to make these adjustments to your configuration.

The fieldbus master-to-HMI block can comprise up to 512 registers, ranging from register 44097 to 44608. This block follows immediately after the standard output data process image (See *Output Data Process Image*, p. 170) block (registers 40001 through 44096) in the island's data image.

The fieldbus master writes output update data in native fieldbus format to the HMI data block concurrent with writing this data to the output data process image area. The output data is placed in the fieldbus master-to-HMI block. Upon request by the HMI via a Modbus *read* command, the role of the NIM is to receive this output data, convert it to 16-bit Modbus format, and send it over the Modbus connection at the CFG port to the HMI panel.

<p><b>Note:</b> The <i>read</i> command enables all Modbus registers to be read, not just those in the block reserved for fieldbus master-to-HMI data exchange.</p>
---



---

# Glossary

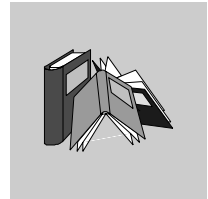

---

## !

- 10Base-T** An adaptation of the IEEE 802.3 (Ethernet) standard, the 10Base-T standard uses twisted-pair wiring with a maximum segment length of 100 m (328 ft) and terminates with an RJ-45 connector. A 10Base-T network is a baseband network capable of transmitting data at a maximum speed of 10 Mbit/s.
- 802.3 frame** A frame format, specified in the IEEE 802.3 (Ethernet) standard, in which the header specifies the data packet length.

---

## A

- agent** **1.** SNMP—the SNMP application that runs on a network device. **2.** Fipio—a slave device on a network.
- analog input** A module that contains circuits that convert analog DC input signals to digital values that can be manipulated by the processor. By implication, these analog inputs are usually direct—i.e., a data table value directly reflects the analog signal value.
- analog output** A module that contains circuits that transmit an analog DC signal proportional to a digital value input to the module from the processor. By implication, these analog outputs are usually direct—i.e., a data table value directly controls the analog signal value.
- application object** In CAN-based networks, application objects represent device-specific functionality, such as the state of input or output data.

- ARP** *address resolution protocol.* IP's network layer protocol uses ARP to map an IP address to a MAC (hardware) address.
- auto baud** The automatic assignment and detection of a common baud rate as well as the ability of a device on a network to adapt to that rate.
- auto-addressing** The assignment of an address to each island bus I/O module and preferred device.
- auto-configuration** The ability of island modules to operate with predefined default parameters. A configuration of the island bus based completely on the actual assembly of I/O modules.
- 

**B**

- BootP** *bootstrap protocol.* A UDP/IP protocol that allows an internet node to obtain its IP parameters based on its MAC address.
- BOS** *beginning of segment.* When more than one segment of I/O modules is used in an island, an STB XBE 1200 BOS module is installed in the first position in each extension segment. Its job is to carry island bus communications to and generate logic power for the modules in the extension segment.
- bus arbitrator** A master on a Fipio network.
- 

**C**

- CAN** *controller area network.* The CAN protocol (ISO 11898) for serial bus networks is designed for the interconnection of smart devices (from multiple manufacturers) in smart systems for real-time industrial applications. CAN multi-master systems ensure high data integrity through the implementation of broadcast messaging and advanced error mechanisms. Originally developed for use in automobiles, CAN is now used in a variety of industrial automation control environments.
- CANopen protocol** An open industry standard protocol used on the internal communication bus. The protocol allows the connection of any standard CANopen device to the island bus.
- CI** *command interface.*
-



---

<b>CiA</b>	<i>CAN in Automation</i> . CiA is a non-profit group of manufacturers and users dedicated to developing and supporting CAN-based higher layer protocols.
<b>COB</b>	<i>communication object</i> . A communication object is a unit of transportation (a "message") in a CAN-based network. Communication objects indicate a particular functionality in a device. They are specified in the CANopen communication profile.
<b>COMS</b>	<i>island bus scanner</i> .
<b>configuration</b>	The arrangement and interconnection of hardware components within a system and the hardware and software selections that determine the operating characteristics of the system.
<b>CRC</b>	<i>cyclic redundancy check</i> . Messages that implement this error checking mechanism have a CRC field that is calculated by the transmitter according to the message's content. Receiving nodes recalculate the field. Disagreement in the two codes indicates a difference between the transmitted message and the one received.

---

**D**

<b>DeviceNet protocol</b>	DeviceNet is a low-level, connection-based network that is based on CAN, a serial bus system without a defined application layer. DeviceNet, therefore, defines a layer for the industrial application of CAN.
<b>DHCP</b>	<i>dynamic host configuration protocol</i> . A TCP/IP protocol that allows a server to assign an IP address based on a role name (host name) to a network node.
<b>differential input</b>	A type of input design where two wires (+ and -) are run from each signal source to the data acquisition interface. The voltage between the input and the interface ground are measured by two high-impedance amplifiers, and the outputs from the two amplifiers are subtracted by a third amplifier to yield the difference between the + and - inputs. Voltage common to both wires is thereby removed. Differential design solves the problem of ground differences found in single-ended connections, and it also reduces the cross-channel noise problem.
<b>digital I/O</b>	An input or output that has an individual circuit connection at the module corresponding directly to a data table bit or word that stores the value of the signal at that I/O circuit. It allows the control logic to have discrete access to the I/O values.
<b>DIN</b>	<i>Deutsche industrial norms</i> . A German agency that sets engineering and dimensional standards and now has worldwide recognition.

---

**E**

- EDS**                    *electronic data sheet.* The EDS is a standardized ASCII file that contains information about a network device's communications functionality and the contents of its object dictionary. The EDS also defines device-specific and manufacturer-specific objects.
- EIA**                    *Electronic Industries Association.* An organization that establishes electrical/ electronic and data communication standards.
- EMC**                    *electromagnetic compatibility.* Devices that meet EMC requirements can operate within a system's expected electromagnetic limits without error.
- EMI**                    *electromagnetic interference.* EMI can cause an interruption, malfunction, or disturbance in the performance of electronic equipment. It occurs when a source electronically transmits a signal that interferes with other equipment.
- EOS**                    *end of segment.* When more than one segment of I/O modules is used in an island, an STB XBE 1000 EOS module is installed in the last position in every segment except the final segment on the island. Its job is to extend island bus communications and send 24 VDC for logic power to the next segment.
- Ethernet**                A LAN cabling and signaling specification used to connect devices within a defined area, e.g., a building. Ethernet uses a bus or a star topology to connect different nodes on a network.0
- Ethernet II**             A frame format in which the header specifies the packet type, Ethernet II is the default frame format for STB NIP 2212 communications.
- 

**F**

- fallback state**        A safe state to which an Advantys STB I/O module can return in the event that its communication connection fails.
- fallback value**        The value that a device assumes during fallback. Typically, the fallback value is either configurable or the last stored value for the device.
- FED\_P**                    *Fipio extended device profile.* On a Fipio network, the standard device profile type for agents whose data length is more than eight words and equal to or less than thirty-two words.

<b>Fipio</b>	<i>Fieldbus Interface Protocol (FIP)</i> . An open fieldbus standard and protocol that conforms to the FIP/World FIP standard. Fipio is designed to provide low-level configuration, parameterization, data exchange, and diagnostic services.
<b>Flash memory</b>	Flash memory is nonvolatile memory that can be overwritten. It is stored on a special EEPROM that can be erased and reprogrammed.
<b>FRD_P</b>	<i>Fipio reduced device profile</i> . On a Fipio network, the standard device profile type for agents whose data length is two words or less.
<b>FSD_P</b>	<i>Fipio standard device profile</i> . On a Fipio network, the standard device profile type for agents whose data length is more than two words and equal to or less than eight words.
<b>full scale</b>	The maximum level in a specific range—e.g., in an analog input circuit the maximum allowable voltage or current level is at full scale when any increase beyond that level is over-range.
<b>function block</b>	A function block performs a specific automation function, such as speed control. A function block comprises configuration data and a set of operating parameters.
<b>function code</b>	A function code is an instruction set commanding one or more slave devices at a specified address(es) to perform a type of action, e.g., read a set of data registers and respond with the content.

---

**G**

<b>gateway</b>	A program or /hardware that passes data between networks.
<b>global_ID</b>	<i>global_identifier</i> . A 16-bit integer that uniquely identifies a device's location on a network. A global_ID is a symbolic address that is universally recognized by all other devices on the network.
<b>GSD</b>	<i>generic slave data (file)</i> . A device description file, supplied by the device's manufacturer, that defines a device's functionality on a Profibus DP network.

---

**H**

- HMI**                    **human-machine interface** An operator interface, usually graphical, for industrial equipment.
- HMI**                    *human-machine interface* An operator interface, usually graphical, for industrial equipment.
- hot swapping**        Replacing a component with a like component while the system remains in operation.
- HTTP**                    *hypertext transfer protocol*. The protocol that a web server and a client browser use to communicate with one another.
- 

**I**

- I/O base**                A mounting device, designed to seat an I/O module, hang it on a DIN rail, and connect it to the island bus. It provides the connection point where the module can receive either 24 VDC or 115/230 VAC from the input or output power bus distributed by a PDM.
- I/O module**            In a programmable controller system, an I/O module interfaces directly to the sensors and actuators of the machine/process. This module is the component that mounts in an I/O base and provides electrical connections between the controller and the field devices. Normal I/O module capacities are offered in a variety of signal levels and capacities.
- I/O scanning**         The continuous polling of the Advantys STB I/O modules performed by the COMS to collect data bits, status, error, and diagnostics information.
- IEC**                        *International Electrotechnical Commission Carrier*. Founded in 1884 to focus on advancing the theory and practice of electrical, electronics, and computer engineering, and computer science. IEC 1131 is the specification that deals with industrial automation equipment.
- IEC type 1 input**      Type 1 digital inputs support sensor signals from mechanical switching devices such as relay contacts and push buttons operating in normal environmental conditions.
-

---

<b>IEC type 1+ input</b>	Type 1+ digital inputs support sensor signals from mechanical switching devices such as relay contacts, push buttons (in normal-to-moderate environmental conditions), three-wire proximity switches and two-wire proximity switches that have: <ul style="list-style-type: none"><li>• a voltage drop of no more than 8 V</li><li>• a minimum operating current capability less than or equal to 2 mA</li><li>• a maximum off-state current less than or equal to 0.8 mA</li></ul>
<b>IEC type 2 input</b>	Type 2 digital inputs support sensor signals from solid state devices or mechanical contact switching devices such as relay contacts, push buttons (in normal or harsh environmental conditions), and two- or three-wire proximity switches.
<b>IEEE</b>	<i>Institute of Electrical and Electronics Engineers, Inc.</i> The international standards and conformity assessment body for all fields of electrotechnology, including electricity and electronics.
<b>industrial I/O</b>	An Advantys STB I/O module designed at a moderate cost for typical continuous, high-duty-cycle applications. Modules of this type often feature standard IEC threshold ratings, usually providing user-configurable parameter options, on-board protection, good resolution, and field wiring options. They are designed to operate in moderate-to-high temperature ranges.
<b>input filtering</b>	The amount of time that a sensor must hold its signal on or off before the input module detects the change of state.
<b>input polarity</b>	An input channel's polarity determines when the input module sends a 1 and when it sends a 0 to the master controller. If the polarity is <i>normal</i> , an input channel will send a 1 to the controller when its field sensor turns on. If the polarity is <i>reverse</i> , an input channel will send a 0 to the controller when its field sensor turns on.
<b>input response time</b>	The time it takes for an input channel to receive a signal from the field sensor and put it on the island bus.
<b>INTERBUS protocol</b>	The INTERBUS fieldbus protocol observes a master/slave network model with an active ring topology, having all devices integrated in a closed transmission path.
<b>IP</b>	<i>internet protocol</i> . That part of the TCP/IP protocol family that tracks the internet addresses of nodes, routes outgoing messages, and recognizes incoming messages.

---

**L**

- LAN** *local area network.* A short-distance data communications network.
- light industrial I/O** An Advantys STB I/O module designed at a low cost for less rigorous (e.g., intermittent, low-duty-cycle) operating environments. Modules of this type operate in lower temperature ranges with lower qualification and agency requirements and limited on-board protection; they usually have limited or no user-configuration options.
- linearity** A measure of how closely a characteristic follows a straight-line function.
- LSB** *least significant bit, least significant byte.* The part of a number, address, or field that is written as the rightmost single value in conventional hexadecimal or binary notation.
- 

**M**

- MAC address** *media access control address.* A 48-bit number, unique on a network, that is programmed into each network card or device when it is manufactured.
- mandatory module** When an Advantys STB I/O module is configured to be mandatory, it must be present and healthy in the island configuration for the island to be operational. If a mandatory module fails or is removed from its location on the island bus, the island will go into a pre-operational state. By default, all I/O modules are not mandatory. You must use the Advantys configuration software to set this parameter.
- master/slave model** The direction of control in a network that implements the master/slave model is always from the master to the slave devices.
- Modbus** Modbus is an application layer messaging protocol. Modbus provides client and server communications between devices connected on different types of buses or networks. Modbus offers many services specified by function codes.
- MSB** *most significant bit, most significant byte.* The part of a number, address, or field that is written as the leftmost single value in conventional hexadecimal or binary notation.
-

---

**N**

<b>N.C. contact</b>	<i>normally closed</i> contact. A relay contact pair that is closed when the relay coil is de-energized and open when the coil is energized.
<b>N.O. contact</b>	<i>normally open</i> . contact. A relay contact pair that is open when the relay coil is de-energized and closed when the coil is energized.
<b>NEMA</b>	<i>National Electrical Manufacturers Association.</i>
<b>network cycle time</b>	The time that a master requires to complete a single scan of all of the configured I/O modules on a network device; typically expressed in microseconds.
<b>NIM</b>	<i>network interface module</i> . This module is the interface between an island bus and the fieldbus network of which the island is a part. The network interface module's built-in power supply provides 5 V logic power to the Advantys STB I/O modules as well as 24 V source power, as needed, to the support I/O modules. The NIM also has an RS-232 interface that is the connection point for the Advantys configuration software.
<b>NMT</b>	<i>network management</i> . NMT protocols provide services for network initialization, error control, and device status control.

---

**O**

<b>object dictionary</b>	Sometimes called the "object directory," this part of the CANopen device model is a map to the internal structure of CANopen devices (according to CANopen profile DS-401). A given device's object dictionary is a lookup table that describes the data types, communications objects, and application objects the device uses. By accessing a particular device's object dictionary structure through the CANopen fieldbus, you can predict its network behavior and, therefore, build a distributed application that implements it.
<b>open industrial communication network</b>	A distributed communication network for industrial environments based on open standards (EN 50235, EN50254, and EN50170, and others) that allows the exchange of data between devices from different manufacturers.
<b>output filtering</b>	The amount that it takes an output channel to send change-of-state information to an actuator after the output module has received updated data from the NIM.

- output polarity** An output channel's polarity determines when the output module turns its field actuator on and when it turns the actuator off. If the polarity is *normal*, an output channel will turn its actuator on when the master controller sends it a 1. If the polarity is *reverse*, an output channel will turn its actuator on when the master controller sends it a 0.
- output response time** The time it takes for an output module to take an output signal from the island bus and send it to its field actuator.
- 

**P**

- parameterize** To supply the required value for an attribute of a device at run-time.
- PDM** *power distribution module*. A module that distributes either AC or DC field power to a cluster of I/O modules directly to its right on the island bus. A PDM delivers field power separately to the input modules and the output modules. It is important that all the I/O clustered directly to the right of a PDM be in the same voltage group—either 24 VDC, 115 VAC, or 230 VAC.
- PDO** *process data object*. In CAN-based networks, PDOs are transmitted as unconfirmed broadcast messages or sent from a producer device to a consumer device. The transmit PDO from the producer device has a specific identifier that corresponds to the receive PDO of the consumer devices.
- PE** *protective earth*. A return line across the bus for fault currents generated at a sensor or actuator device in the control system.
- peer-to-peer communications** In peer-to-peer communications, there is no master/slave or client/server relationship. Messages are exchanged between entities of comparable or equivalent levels of functionality, without having to go through a third party (like a master device).
- PLC** *programmable logic controller*. The PLC is the brain of an industrial manufacturing process. It automates a process as opposed to relay control systems. PLCs are computers suited to survive the harsh conditions of the industrial environment.



---

<b>preferred module</b>	An I/O module that functions as an auto-addressable node on an Advantys STB island but is not in the same form factor as a standard Advantys STB I/O module and therefore does not fit in an I/O base. A preferred device connects to the island bus via an STB XBE 1000 EOS module and a length of STB XCA 100x bus extension cable. It can be extended to another preferred module or back into a standard island segment. If it is the last device on the island, it must be terminated with a 120 $\Omega$ terminator.
<b>premium network interface</b>	An Advantys STB network interface module designed at a relatively high cost to support high module densities, high transport data capacity (e.g., for web servers), and more diagnostics on the island bus.
<b>prioritization</b>	Prioritization is an optional feature that allows you to selectively identify digital input modules to be scanned more frequently during the NIM's logic scan of the island bus.
<b>process I/O</b>	An Advantys STB I/O module designed for operation at extended temperature ranges in conformance with IEC type 2 thresholds. Modules of this type often feature high levels of on-board diagnostics, high resolution, user-configurable parameter options, and higher levels of agency approval.
<b>process image</b>	A part of the NIM firmware that serves as a real-time data area for the data exchange process. The process image includes an input buffer that contains current data and status information from the island bus and an output buffer that contains the current outputs for the island bus, from the fieldbus master.
<b>producer/consumer model</b>	In networks that observe the producer/consumer model, data packets are identified according to their data content rather than by their physical location. All nodes "listen" on the network and consume those data packets that have appropriate identifiers.
<b>Profibus DP</b>	<i>Profibus Decentralized Peripheral</i> . An open bus system that uses an electrical network based on a shielded two-wire line or an optical network based on a fiber-optic cable. DP transmission allows for high-speed, cyclic exchange of data between the controller CPU and the distributed I/O devices.

---

**R**

<b>reflex action</b>	The execution of a simple, logical command function configured locally at an island bus I/O module. Reflex actions are executed by island bus modules on data from various island locations, like input and output modules or the NIM. Examples of reflex actions include compare and copy operations.
----------------------	--

<b>repeater</b>	An interconnection device that extends the permissible length of a bus.
<b>reverse polarity protection</b>	Use of a diode in a circuit to protect against damage and unintended operation in the event that the polarity of the applied power is accidentally reversed.
<b>rms</b>	<i>root mean square.</i> The effective value of an alternating current, corresponding to the DC value that produces the same heating effect. The rms value is computed as the square root of the average of the squares of the instantaneous amplitude for one complete cycle. For a sine wave, the rms value is 0.707 times the peak value.
<b>role name</b>	A customer-driven, unique logical personal identifier for an Ethernet Modbus TCP/IP NIM. A role name is created either as a combination of a numeric rotary switch setting and the STB NIP 2212 part number or by modifying text on the Configure Role Name web page. After the STB NIP 2212 is configured with a valid role name, the DHCP server will use it to identify the island at power up.
<b>RTD</b>	<i>resistive temperature detect.</i> An RTD device is a temperature transducer composed of conductive wire elements typically made of platinum, nickel, copper, or nickel-iron. An RTD device provides a variable resistance across a specified temperature range.
<b>Rx</b>	<i>reception.</i> For example, in a CAN-based network, a PDO is described as an RxPDO of the device that receives it.

---

**S**

<b>SAP</b>	<i>service access point.</i> The point at which the services of one communications layer, as defined by the ISO OSI reference model, is made available to the next layer.
<b>SCADA</b>	<i>supervisory control and data acquisition.</i> Typically accomplished in industrial settings by means of microcomputers.
<b>SDO</b>	<i>service data object.</i> In CAN-based networks, SDO messages are used by the fieldbus master to access (read/write) the object directories of network nodes.
<b>segment</b>	A group of interconnected I/O and power modules on an island bus. An island must have at least one segment and may have as many as seven segments. The first (leftmost) module in a segment needs to provide logic power and island bus communications to the I/O modules on its right. In the primary segment, that function is filled by a NIM. In an extension segment, that function is filled by an STB XBE 1200 BOS module.

---

<b>SELV</b>	<i>safety extra low voltage.</i> A secondary circuit designed and protected so that the voltage between any two accessible parts (or between one accessible part and the PE terminal for Class 1 equipment) does not exceed a specified value under normal conditions or under single-fault conditions.
<b>SIM</b>	<i>subscriber identification module.</i> Originally intended for authenticating users of mobile communications, SIMs now have multiple applications. In Advantys STB, configuration data created or modified with the Advantys configuration software can be stored on a SIM and then written to the NIM's Flash memory.
<b>single-ended inputs</b>	An analog input design technique whereby a wire from each signal source is connected to the data acquisition interface, and the difference between the signal and ground is measured. Two conditions are imperative to the success of this design technique—the signal source must be grounded, and the signal ground and data acquisition interface ground (the PDM lead) must have the same potential.
<b>sink load</b>	An output that, when turned on, receives DC current from its load.
<b>size 1 base</b>	A mounting device, designed to seat an STB module, hang it on a DIN rail, and connect it to the island bus. It is 13.9 mm wide and 128.25 mm high.
<b>size 2 base</b>	A mounting device, designed to seat an STB module, hang it on a DIN rail, and connect it to the island bus. It is 18.4 mm wide and 128.25 mm high.
<b>size 3 base</b>	A mounting device, designed to seat an STB module, hang it on a DIN rail, and connect it to the island bus. It is 28.1 mm wide and 128.25 mm high.
<b>slice I/O</b>	An I/O module design that combines a small number of channels (usually between two and six) in a small package. The idea is to allow a system developer to purchase just the right amount of I/O and to be able to distribute it around the machine in an efficient, mechatronics way.
<b>SM_MPS</b>	<i>state management_message periodic services.</i> The applications and network management services used for process control, data exchange, error reporting, and device status notification on a Fipio network.
<b>SNMP</b>	<i>simple network management protocol.</i> The UDP/IP standard protocol used to manage nodes on an IP network.
<b>snubber</b>	A circuit generally used to suppress inductive loads—it consists of a resistor in series with a capacitor (in the case of an RC snubber) and/or a metal-oxide varistor placed across the AC load.
<b>source load</b>	A load with a current directed into its input; must be driven by a current source.

**standard network interface**

An Advantys STB network interface module designed at moderate cost to support the kind of configuration capabilities and throughput capacity suitable for most standard applications on the island bus.

**STD\_P**

*standard profile.* On a Fipio network, a standard profile is a fixed set of configuration and operating parameters for an agent device, based on the number of modules that the device contains and the device's total data length. Three types of standard profiles are available—Fipio reduced device profile (FRD\_P), Fipio standard device profile (FSD\_P), and the Fipio extended device profile (FED\_P).

**stepper motor**

A specialized DC motor that allows discrete positioning without feedback.

**subnet**

A part of a network that shares a network address with the other parts of a network. A subnet may be physically and/or logically independent of the rest of the network. A part of an internet address called a subnet number, which is ignored in IP routing, distinguishes the subnet.

**surge suppression**

The process of absorbing and clipping voltage transients on an incoming AC line or control circuit. Metal-oxide varistors and specially designed RC networks are frequently used as surge suppression mechanisms.

---

**T**

**TC**

*thermocouple.* A TC device is a bimetallic temperature transducer that provides a temperature value by measuring the voltage differential caused by joining together two different metals at different temperatures.

**TCP**

*transmission control protocol.* A connection-oriented transport layer protocol that provides reliable full-duplex data transmission. TCP is part of the TCP/IP suite of protocols.

**telegram**

A data packet used in serial communication.

**TFE**

*transparent factory Ethernet.* Schneider Electric's open automation framework based on TCP/IP.

**Tx**

*transmission.* For example, in a CAN-based network, a PDO is described as a TxPDO of the device that transmits it.

---

**U**

**UDP** *user datagram protocol.* A connectionless mode protocol in which messages are delivered in a datagram to a destination computer. The UDP protocol is typically bundled with the Internet Protocol (UPD/IP).

---

**V**

**varistor** A two-electrode semiconductor device with a voltage-dependant nonlinear resistance that drops markedly as the applied voltage is increased. It is used to suppress transient voltage surges.

**voltage group** A grouping of Advantys STB I/O modules, all with the same voltage requirement, installed directly to the right of the appropriate power distribution module (PDM) and separated from modules with different voltage requirements. Never mix modules with different voltage requirements in the same voltage group.

---

**W**

**watchdog timer** A timer that monitors a cyclical process and is cleared at the conclusion of each cycle. If the watchdog runs past its programmed time period, it generates a fault.

---



---

# Index

---



## Numerics

10Base-T, 26  
802.3 standard, 21, 27, 42

## A

ABL7 RE2403 Telefast 24 VDC power supply, 41  
action module, 159  
addressable module, 17, 46, 47, 118, 142  
Advantys configuration software, 20, 33, 80, 91, 116, 134, 147, 150, 154, 156, 158, 160, 164, 165, 168, 171  
auto-addressing, 17, 46, 57  
auto-configuration  
    and reset, 49, 56, 57  
    defined, 49  
    initial configuration, 49

## B

baud  
    CFG port, 33, 56  
    fieldbus interface, 56  
BootP server, 29, 60, 62, 64

## C

Category 5 (CAT5) cabling, 27, 42  
CFG port  
    devices connecting to, 12, 33, 34  
    master configurator, 80  
    parameters, 33, 57  
    physical description, 33  
community names, 105, 106  
configurable parameters, 150  
configuration data  
    restoring default settings, 33, 53, 57  
    saving, 53, 57  
Configuration menu, 72  
configuration password, 67, 90, 91  
custom configuration, 49, 50, 53, 56, 154, 164, 165  
customer support, 69

## D

data exchange, 12, 31, 46, 94, 116, 117, 147, 172, 173  
data image, 117, 167, 169, 172  
data size, 152  
default IP address, 61, 62, 64, 74, 76  
DHCP server, 29, 60, 62, 64  
diagnostics block  
    in the process image, 125  
    island communications, 125  
Diagnostics menu, 93

**E**

edit mode, 50, 53, 54, 56  
embedded web server  
  access, 68  
  help, 67  
  managing, 112  
  navigation, 68  
  overview, 19  
  process image, 116  
  product support, 69  
  security, 67, 87  
  troubleshooting, 125

## Ethernet

  host, 19, 20, 116, 138  
  port, 20, 26, 31, 74, 80, 116  
  specification, 21, 27  
  statistics, 94, 135  
Ethernet LAN, 19, 21, 26, 28, 31, 73, 80,  
116, 135  
extension cable, 16, 38  
extension module, 13, 16, 37, 38, 39, 40, 46  
extension segment, 13, 16, 38, 39, 40

**F**

factory default settings, 33, 49, 53, 57  
fallback state, 154, 162  
fallback value, 154, 163  
fieldbus master  
  and the output data image, 171  
  communicating the island's status to, 132  
  configuring, 78, 106  
  fieldbus-to-HMI block, 173  
  HMI-to-fieldbus block, 172  
  setting up communications with the  
  island bus, 78, 106  
Flash memory  
  Advantys configuration software, 164  
  and reset, 55, 57  
  overwriting, 53, 57, 165  
  saving configuration data, 49  
frame type  
  default, 21  
  Ethernet II, 21, 64, 74, 133  
  IEEE 802.3, 21, 64, 74, 133

**H**

HE-13 connector, 34  
heartbeat message, 162  
HMI panel  
  data exchange, 12, 20, 150, 152, 168,  
  172, 173  
  functionality, 172  
  process image blocks, 172  
hot-swapping modules, 48, 154, 155  
HTTP server, 19, 67, 68, 70, 87, 116

**I**

initial configuration, 53, 54  
inputs  
  to a reflex block, 158  
Internet, 19, 28, 60, 73  
Internet browser, 67  
IP address  
  BootP, 29  
  change, 74, 84, 85, 95  
  default, 61, 62, 64, 74, 76  
  MAC address, 61, 62, 64, 76  
  role name, 84  
  setting, 28, 60, 63, 75  
  software priorities, 64  
IP address field, 73, 75  
IP parameters, 63, 73, 74, 76  
island bus  
  communications, 12  
  configuration data, 50, 53, 57, 80,  
  99, 165  
  extending, 16, 38  
  fallback, 162  
  IP address, 60, 72, 73, 83  
  LEDs, 31  
  maximum length, 18  
  operational mode, 31, 53, 56  
  overview, 14, 15  
  status, 30, 125  
  termination, 14, 17  
island bus example, 47, 117, 141



island bus node address  
  address range, 29  
  setting, 60, 73, 76  
  valid and invalid addresses, 29  
island bus password, 165

## L

### LEDs

  10T ACT, 31  
  and COMS states, 31  
  and reset, 31  
  ERROR, 31  
  island bus, 31  
  LAN ST, 31  
  overview, 30  
  RUN, 31  
  TEST, 31

### logic power

  considerations, 13, 16, 37, 38, 40  
  integrated power supply, 12, 13, 37, 39, 40  
  signal, 38  
  source power supply, 13, 39

## M

MAC address, 61, 62, 64, 76  
mandatory I/O modules, 154  
MIB II, 108, 110  
Modbus function codes, 134, 147  
Modbus protocol, 33, 34, 116, 133, 142, 166, 169, 172  
Modbus over TCP/IP  
  and master controllers, 78  
  connection example, 138, 145  
  data formats, 64, 133, 142  
  fieldbus interface, 26  
  fieldbus master, 116, 117  
  input data image, 120  
  output data image, 119  
  Port 502 SAP, 19, 42  
  protocol, 20  
  troubleshooting, 125

## N

nested reflex actions, 160  
network architecture, 139  
network considerations, 12, 19, 26, 28, 31, 54, 60  
number of reflex blocks on an island, 161

## O

### outputs

  from a reflex block, 159

## P

parameterization, 49  
PDM, 38, 41, 46, 47, 118, 142  
PLC, 19, 20, 133, 151  
preferred module, 17  
primary segment, 13, 15, 38, 40  
prioritization, 156  
private MIB, 108, 109, 110, 111, 113  
process image  
  analog input and output module data, 120, 171  
  and reflex actions, 120  
  connection example, 146  
  custom view, 96  
  diagnostic block, 125  
  digital input and output module data, 120, 171  
  echo output data, 120  
  embedded web server, 116  
  fieldbus-to-HMI block, 173  
  graphical representation, 167  
  HMI blocks, 172  
  HMI-to-fieldbus block, 172  
  I/O status image, 120, 166, 171, 172  
  input data image, 97, 120, 171, 172  
  output data image, 97, 119, 170, 173  
  overview, 166  
protected mode, 33, 50, 53, 54, 56, 67, 87, 91, 165

## R

- reboot operation, 77, 85
- reflex action
  - and fallback, 163
  - and the echo output data image area, 117, 120, 171
  - overview, 157
- reflex block types, 157
- removable memory card, 50, 52, 53, 164
- RJ-45 connector, 26, 27
- role name, 62, 63, 64, 83, 84
- rotary switches, 28, 62
- RST button
  - and auto-configuration, 57
  - and Flash memory, 55, 57
  - caution, 55, 56
  - disabled, 33, 165
  - functionality, 49, 55, 56
  - LED indications, 31
  - physical description, 55

## S

- security
  - configuration password, 90, 91
  - private community strings, 105, 106
  - web access password, 88
  - web site, 87, 90, 91
- Simple Network Management Protocol (SNMP), 19, 104, 105, 106, 108, 110
- SNMP agent, 104
- SNMP manager, 105
- source power supply
  - considerations, 40
  - logic power, 13, 39
  - recommendations, 41
  - SELV-rated, 35, 37, 39, 40
  - two-receptacle wiring connector, 35
- specifications
  - CFG port, 33
  - Ethernet transmission, 21, 27
  - MIB II, 108, 110
  - STB NIP 2212, 21, 42
  - STB XCA 4002 programming cable, 34
- standard I/O modules, 154

- STB XCA 4002 programming cable, 34
- STB XTS 1120 screw type power connector, 36
- STB XTS 2120 spring clamp field wiring connector, 36
- STB NIP 2212
  - and the Internet, 19
  - configuration mastery of, 81
  - configuring for IP, 29, 60, 63, 72, 73, 74
  - Ethernet LAN, 21
  - fieldbus (Ethernet) port, 26, 27
  - LEDs, 30
  - limitations, 42
  - master controller(s), 79
  - physical features, 24
  - power supply interface, 35
  - specifications, 21, 42
  - troubleshooting, 93, 94, 101, 132
- STB NIP 2212 diagnostics, 108
- STB NIP 2212 web site, 67, 70, 83, 88, 91
- STB XMP 4440 removable memory card
  - and reset, 33
  - installing, 51
  - physical description, 50
  - removing, 52
  - storing configuration data, 53
- storing configuration data
  - and reset, 57
  - in Flash memory, 49, 154, 164
  - to a removable memory card, 50, 53, 154, 164
- STP (shielded twisted pair) cable, 27, 42

## T

- termination plate, 14, 47, 118, 142
- test mode, 31
- troubleshooting
  - emergency messages, 130
  - error log, 101
  - global bits errors, 127
  - island bus, 97, 128, 129, 131
  - Modbus registers, 95

---

- STB NIP 2212, 93, 94, 101, 108, 110, 132
  - using the Advantys STB LEDs, 31
  - using the Ethernet LAN LEDs, 31
  - web-based, 93, 94, 95, 97, 101
  - with the Advantys configuration software, 125
  - with the HMI panel, 125
- TSX SUP 1011 Premium 24 VDC power supply, 41
- TSX SUP 1021 Premium 24 VDC power supply, 41
- TSX SUP 1051 Premium 24 VDC power supply, 41
- TSX SUP 1101 Premium 24 VDC power supply, 41

## U

- user datagram protocol (UDP), 104, 105
- UTP (unshielded twisted pair) cable, 27, 42

## W

- web access password, 67, 89
- web pages
  - access, 72, 93
  - Change Configuration Password, 90
  - Change Web Access Password, 88
  - Configure SNMP, 106, 107
  - Configured IP, 62, 73, 75
  - Error Log, 101
  - Ethernet Statistics, 94
  - I/O Data Values, 98
  - Island Configuration, 99
  - Island Parameters, 100
  - login, 90, 91
  - Master Configurator, 81, 82
  - Master Controller, 78, 79
  - navigation, 72, 93
  - NIM Registers, 96
  - Properties, 70
  - Reboot, 77, 85
  - Role Name, 62, 83

