

Milk, Ice Cream and Milk & Ice Cream Dispensers Service and Installation Manual

Please read this manual completely before attempting to install or operate this equipment! **Notify carrier of damage!** Inspect all components immediately.



N, N6/N10/N14
Free-standing milk or
beverage dispensers



NDF
Free-standing milk or
beverage dispensers

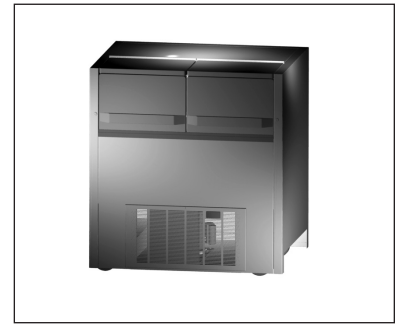

NLFAC
Free-standing milk or beverage
dispensers with air curtain



NSCF, SCF
Free-standing ice cream
dispensers and milk & ice
cream dispensers

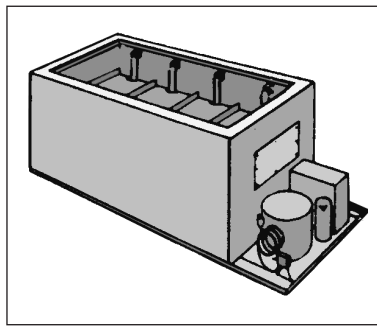

MF, MFSC
Built-in milk or beverage
dispensers



Important Information
Read Before Use
Please Save These Instructions!

Important Warning And Safety Information



WARNING

Read This Manual Thoroughly Before Operating, Installing, Or Performing Maintenance On The Equipment.



WARNING

Failure To Follow Instructions In This Manual Can Cause Property Damage, Injury Or Death.



WARNING

Do Not Store Or Use Gasoline Or Other Flammable Vapors Or Liquids In The Vicinity Of This Or Any Other Appliance.



WARNING

Unless All Cover And Access Panels Are In Place And Properly Secured, Do Not Operate This Equipment.



WARNING

This Appliance Is Not Intended For Use By Persons Who Lack Experience Or Knowledge, Unless They Have Been Given Supervision Or Instruction Concerning Use Of The Appliance By A Person Responsible For Their Safety.



WARNING

This Appliance Is Not To Be Played With.



WARNING

Do Not Clean With Water Jet.



WARNING

Do Not Use Electrical Appliances Inside The Food Storage Compartment Of This Appliance.



CAUTION

Observe the following:

- Minimum clearances must be maintained from all walls and combustible materials.
- Keep the equipment area free and clear of combustible material.
- Allow adequate clearance for air openings.
- Operate equipment only on the type of electricity indicated on the specification plate.
- Unplug the unit before making any repairs.
- Retain this manual for future reference.

Contents

Receiving and Inspecting Equipment	3
Serial Number Location	4
Warranty Information.....	4
Regulatory Certifications.....	4
Specifications	5
Installation.....	6-7
Operation.....	8
Maintenance.....	9
Wiring Diagram	10
Replacement Parts.....	11-17
Standard Labor Guidelines	18
Notes	19

Receiving and Inspecting the Equipment

Even though most equipment is shipped crated, care should be taken during unloading so the equipment is not damaged while being moved into the building.

1. Visually inspect the exterior of the package and skid or container. Any damage should be noted and reported to the delivering carrier immediately.
2. If damaged, open and inspect the contents with the carrier.
3. In the event that the exterior is not damaged, yet upon opening, there is concealed damage to the equipment notify the carrier. Notification should be made verbally as well as in written form.
4. Request an inspection by the shipping company of the damaged equipment. This should be done within 10 days from receipt of the equipment.
5. Check the lower portion of the unit to be sure casters are not bent.
6. Also open the compressor compartment housing and visually inspect the refrigeration package. Be sure lines are secure and base is still intact.
7. Freight carriers can supply the necessary damage forms upon request.
8. Retain all crating material until an inspection has been made or waived.

Uncrating the Equipment

First cut and remove the banding from around the crate. Remove the front of the crate material, use of some tools will be required. If the unit is on legs remove the top of the crate as well and lift the unit off the skid. If the unit is on casters it can be rolled off the skid.

Serial Number Location

Serial number tag locations

MF/MFSC — on the end above the refrigeration system.

N, N6/N10/N14, and SCF — rear of the unit above the louver.

NDF — Front right hand corner under the lid.

NLFAC — at the rear of the unit by the power cord.

Always have the serial number of your unit available when calling for parts or service. A complete list of authorized Delfield parts depots is available at www.delfield.com.

The units represented in this manual are for indoor use only.

©2013 The Delfield Company. All rights reserved. Reproduction without written permission is prohibited. "Delfield" and "Shelleymatic" are registered trademarks of The Delfield Company.

Warranty Information

Visit http://www.delfield.com/minisite/service/warranty_info to:

- Register your product for warranty.
- Verify warranty information.
- View and download a copy of your warranty.

Regulatory Certifications

All models are certified by:



National Sanitation Foundation (NSF)



Underwriters Laboratories (UL)

Specifications

<i>Model</i>	<i>H.P.</i>	<i>Loading/Dispensing</i>	<i>Weight (lbs)</i>	<i>Amps (115V)</i>	<i>NEMA Plug</i>	<i>BTU Load</i>	<i>Evap BTU/ TD</i>	<i>BTU Capacity</i>	<i>Ref/Charge</i>
Self-contained free-standing milk or beverage dispensers									
N-520	1/4	sliding top lids	327	5.0	5-15P	189	33/31°	1035	134a/16oz
N-860	1/4	sliding top lids	392	5.0	5-15P	259	42/28°	1167	134a/16oz
N-1200	1/4	sliding top lids	462	5.0	5-15P	328	51/25°	1273	134a/16oz
N-1530	1/4	sliding top lids	532	5.0	5-15P	398	60/23°	1360	134a/16oz
N6-1313-34	1/4	sliding top lids	382	5.0	5-15P	245	42/28°	1167	134a/16oz
N6-1313-36	1/4	sliding top lids	402	5.0	5-15P	245	42/28°	1167	134a/16oz
N10-1313-34	1/4	sliding top lids	545	5.0	5-15P	353	55/24°	1315	134a/16oz
N10-1313-36	1/4	sliding top lids	565	5.0	5-15P	353	55/24°	1315	134a/16oz
N14-1313-34	1/4	sliding top lids	650	5.0	5-15P	455	68/21°	1422	134a/16oz
N14-1313-36	1/4	sliding top lids	670	5.0	5-15P	455	68/21°	1422	134a/16oz
Self-contained free-standing milk or beverage dispensers									
NDF-12	1/4	drop front & flip top lids	365	5.0	5-15P	687	49/25°	1204	134a/16oz
NDF-18	1/3	drop front & flip top lids	430	7.0	5-15P	898	60/27°	1585	134a/24oz
Self-contained free-standing milk or beverage dispensers with air curtain (BTU is with lids closed.)									
NLFAC-8	1/3	hinged lids w/air curtain	401	7.0	5-15P	668	140/16°	2184	134a/24oz
NLFAC-12	1/2	hinged lids w/air curtain	491	9.0	5-15P	859	140/21°	2885	134a/32oz
NLFAC-16	1/2	hinged lids w/air curtain	583	11.0	5-15P	1050	140/23°	3193	134a/32oz
Self-contained free-standing milk and ice cream dispensers									
NSCF-48	1/4	hinged top lids	390	7.1	5-15P	139(ref) 414(frz)	37/43°(ref) 37/21°(frz)	1596(ref) 796(frz)	404A/16oz
Self-contained free-standing ice cream dispensers									
SCF-32	1/4	hinged top lids	334	7.1	5-15P	709	51/18°	915	404A/16oz
SCF-48	1/3	hinged top lids	414	8.0	5-15P	1043	69/19°	1350	404A/24oz
<i>Model</i>	<i>H.P.</i>	<i>Cutout Dim. (L x D)</i>	<i>Weight (lbs)</i>	<i>Amps (115V)</i>	<i>NEMA Plug</i>	<i>BTU Load</i>	<i>Evap BTU/ TD</i>	<i>BTU Capacity</i>	<i>Ref/Charge</i>
Self-contained built-in milk or beverage dispensers *a 2.87" space is required between each cutout									
MFSC-2020	1/4	(1) 25.25" x 22.25"	303	5.0	5-15P	304	51/24°	1223	134a/16oz
MFSC-2821	1/4	(1) 10.75" x 21"	267	5.0	5-15P	264	45/26°	1166	134a/16oz
MFSC-31	1/4	(2) 10.75" x 21"*	306	5.0	5-15P	296	50/24°	1212	134a/16oz
MFSC-44	1/4	(3) 10.75" x 21"*	413	5.0	5-15P	408	64/21°	1346	134a/16oz
MFSC-57	1/4	(4) 10.75" x 21"*	461	5.0	5-15P	519	79/18°	1447	134a/16oz
Remote built-in milk or beverage dispensers *a 2.87" space is required between each cutout									
MF-2020	N/A	(1) 25.25" x 22.25"	240	N/A	N/A	304	51/24°	N/A	134a/N/A
MF-2821	N/A	(1) 10.75" x 21"	197	N/A	N/A	264	45/26°	N/A	134a/N/A
MF-31	N/A	(2)10.75" x 21"*	238	N/A	N/A	296	50/24°	N/A	134a/N/A
MF-44	N/A	(3)10.75" x 21"*	312	N/A	N/A	408	64/21°	N/A	134a/N/A
MF-57	N/A	(4) 10.75" x 21"*	335	N/A	N/A	519	79/18°	N/A	134a/N/A



Installation

Location

These units are intended for indoor use only. Be sure the location chosen has a floor strong enough to support the total weight of the cabinet and contents. Units in this product line can weigh as much as 1500 pounds when it is fully stocked. Reinforce the floor as necessary to provide for maximum loading.

For the most efficient refrigeration, be sure to provide good air circulation inside and out.

Inside cabinet: Do not pack unit so full that air cannot circulate. Take care not to block air flow to the fans and allow space along sides.

Outside cabinet: Be sure that the unit has access to ample air. Avoid hot corners and locations near stoves and ovens. It is recommended that the rear of the unit be no less than two inches from any wall, partition or any other object which will restrict exhaust air flow.

Leveling

A level cabinet looks better and will perform better because the cabinet will not be subject to unnecessary strain due to doors not properly lining up with door frames.

Some models have casters for ease of cleaning underneath and for mobility. It is important that the unit be installed in a stable condition with the front casters locked before operating. Locking the front casters after installation is the operator's responsibility.

Electrical connection

A standard self-contained unit is provided with a power cord and three-prong grounded plug.

The unit should be plugged into a receptacle with its own circuit protection that matches the amperage of the plug.



Refer to the amperage data on specifications page or the serial tag data and your local code or the National Electrical Code to be sure the unit is connected to the proper power source. A protected circuit of the correct voltage and amperage must be run for connection to the unit.



The power supply must be disconnected whenever performing maintenance or repairing the equipment!



The unit must never be operated without the louvered panel in place.

Built-in units

All self-contained units (MFSC) are tested at the factory to assure proper operation. The unit should not be installed directly next to high heat generating equipment (ranges, griddles, etc.).

These units are built into the counter from below and must be supported from the bottom. The counter cut-out sizes and power supply requirements are shown on the specifications page. All refrigerators have drains located in the bottom of the tank. An appropriate drainage area or container must be provided by the customer. Be sure to place the unit so the pressure control, located near the compressor, can be reached.

For installation of remote units (MF), consult a refrigeration service company to connect refrigeration lines to the remote condensing unit.



Self-contained refrigerated units (MFSC) require air flow to the compressor. A louver is provided and must be installed in the counter in front of the condenser. An equal size opening at the rear of the cabinet must also be provided to allow warm air to escape. Failure to do so will void all product warranties.

Free standing units

All self-contained units (N, N6/10/14, NDF, NLFAC, SCF and NSCF) are tested at the factory to assure proper operation. The unit should not be installed directly next to high heat generating equipment (ranges, griddles, etc.).

These units are free standing, either on legs or casters. The power supply requirements are shown on the specifications page. All free standing units have drains located in the bottom of the tank. An appropriate drainage area or container must be provided by the customer.

Do not place the unit against a wall or any object that will block air circulation through the condensing unit. If the unit must be placed against a wall, leave a minimum of 2" of space for air flow.

Installation Continued

How to adjust self-leveling dispenser

Tools Needed: One small flat head screw driver; One Phillips head screw driver.

1. Always wear safety glasses when adjusting your dispenser. Also, lock brakes on mobile units before beginning.
2. Unload dispenser and remove stainless steel load tray by lifting straight up and set it aside (see figure 1).

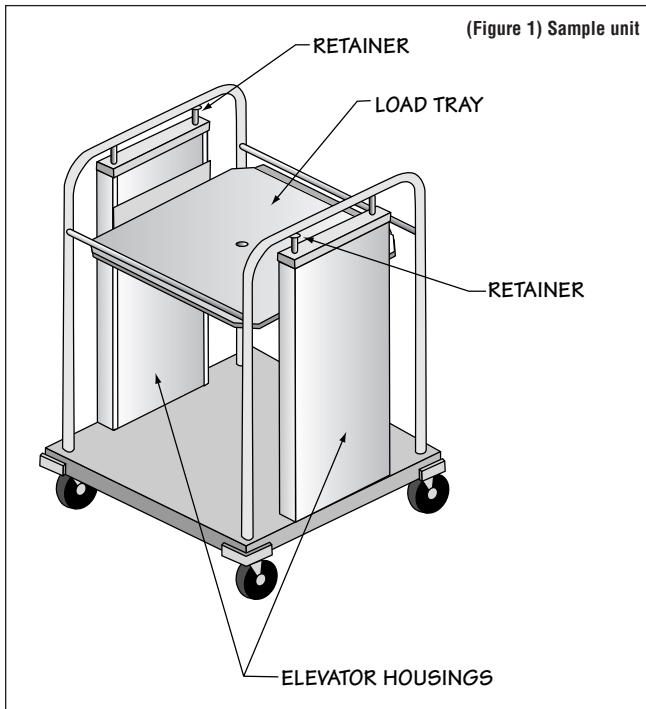

3. Use small regular screw driver to loosen each retainer mounted on stainless steel rod at top of each elevator housing.

4. To remove elevator housing, lift housing straight up to clear the stud on unit base. Then gently swing the bottom of the housing towards the inside of the unit and pull housing out of the unit (see figure 2). Lay housing on flat surface.



5. Use Phillips head screw driver to remove front panel on the elevator housing (see figure 3).

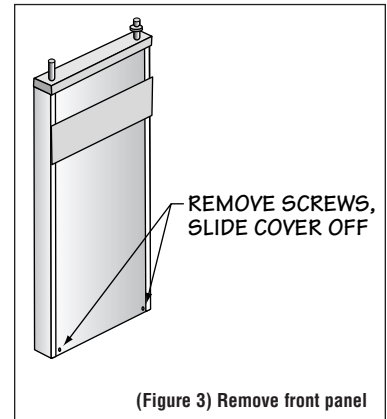

6. If carrier is riding too high, you need to remove springs. With carrier all the way to the top, gently disengage one spring at a time, unhooking bottom loop out of carrier bracket (see figure 4). Remove as many springs as necessary.

If carrier is riding too low, you need to add springs. With carrier all the way to the top, gently engage one spring at a time by hooking bottom loop of spring into carrier bracket. Add as many springs as necessary.

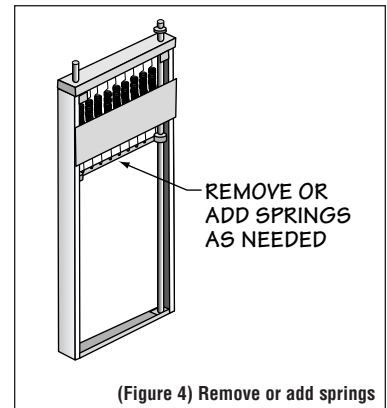

7. When finished, put elevator housing back in unit and put stainless steel load tray back on elevator housings. Load unit to test dispensing level. If spring adjustment does not position carrier properly, repeat procedure #6 trying different springs. If this does not work, a different set of springs may be required. To order, call The Delfield Company Parts and Service Department at 800.733.8829
8. If level is appropriate, put front panels back on and tighten retainer.



CAUTION: Dispenser should not be operated with front panels off elevator housing.

NOTE: When adjusting the elevators make sure each have the same number and size of springs connected to the carrier on both sides. This will prevent the load tray from binding.

Operation: N, N6/10/14, NDF, NLFAC, MF & MFSC Series

N, N6/10/14, NDF, NLFAC and MFSC Series milk dispensers are set at the factory to maintain temperatures between 36°F and 40°F. No further adjustment should be necessary. To begin operation on self-contained models, plug the electrical supply cord into a receptacle with the correct voltage. Remote models will require a connection to a separate refrigeration system.

Loading: N, MF & MFSC Series

To load, place a complete layer of cartons or bottles standing upright on the load tray. Then place a divider tray on top of this layer, then another layer of cartons or bottles on this tray, then another tray and another layer, etc. As each additional tray is loaded, the elevators gradually lower. The last layer may be placed on top without the use of another tray. When loading the average tall half pint bottles, four layers may be loaded into each compartment standing upright and the fifth layer laying down.



It is very important to use the divider trays provided between each successive layer of contents to assure the correct balance of the load and the proper action of the elevating mechanism.

Wire racks, when used, should be loaded completely. When placing one rack on top of the other, be sure the stacking lugs are properly aligned.

Loading: N6/10/14 Series

These cabinets are designed to dispense 13" x 13" x 11" high (maximum dimensions) dairy cases. Place one case loaded with milk on the carrier and then place a second case loaded with milk on top of the first case. Press down on the cases

leaning them toward the retaining bracket located under the top lid track, then gradually release pressure on the cases so that the top edge of the case engages with the retaining bracket.

The elevating mechanism is designed to keep the contents several inches below the top of the cabinet when fully loaded. This distance serves two purposes:

- A. It keeps the top layer of milk completely refrigerated even when the lids are removed.
- B. It insures that the lids will operate without striking the contents as successive layers are added.

Loading: NDF Series

These cabinets are designed to dispense 13" x 13" x 11" high (maximum dimensions) dairy cases. They do not have a self-leveling mechanism. Simply place the cases on top of each other inside the cabinet through the wide opening in the top and front.

Loading: NLFAC Series

These cabinets are designed to dispense 13" x 13" x 11" high (maximum dimensions) dairy cases. Model NLFAC-8 holds eight cases; four on the bottom and four on the top. Model NLFAC-12 holds twelve cases; six on the bottom and six on the top. Model NLFAC-16 holds sixteen cases, eight on the bottom and eight on the top.

Milk cases are loaded through the wide opening in the top and front of the unit. Fold the hinged lids up and back and rest them on the top. The cabinet interior has self-locating guides installed to make loading easy.

Operation: SCF & NSCF series

SCF Series ice cream dispensers are set at the factory to maintain temperatures between -5°F and 0°F. NSCF Series combination milk and ice cream dispensers are set at the factory to maintain temperatures between 36°F and 40°F for refrigerated product and between -5°F and 0°F for frozen product. Each combination unit is constructed with two tanks and separate controls. No further adjustments should be necessary. To begin operation plug the electrical supply cord

into a receptacle with the correct voltage.

Loading

To load, place two layers of ice cream on the load tray, then a tray, two additional layers of ice cream, then another tray, etc. Do not stack ice cream above the frost line on the interior of the freezer. See the instructions for the MF units (above) for loading the refrigerated portion of the combination units.

Temperature Control

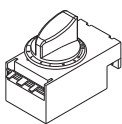

NLFAC Thermostat Control

Set the thermostat toward 1 for higher temperatures and toward 7 for lower temperatures. The refrigerator factory setting is 4 and maintains 38°F (3°C) in the box.

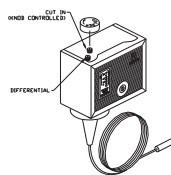

Low Pressure Control, Remaining Self Contained Models

If it is necessary to adjust the temperature, turn the knob clockwise as indicated on the control. Make adjustments gradually. It may take an hour to realize the temperature change. Milk or beverage dispenser factory settings are 17°F differential, 34°F cut in, and 17°F cut out. Milk and ice cream dispenser factory settings are 25°F differential, 30°F cut in, and 5°F cut out.

Maintenance

Door Gasket Maintenance

Door gaskets require regular cleaning to prevent mold and mildew build up and also to retain the elasticity of the gasket. Gasket cleaning can be done with the use of warm soapy water. Avoid full strength cleaning products on gaskets as this can cause them to become brittle and crack. Never use sharp tools or knives to scrape or clean the gasket. Gaskets can be easily replaced and do not require the use of tools or an authorized service person. The gaskets are "Dart" style and can be pulled out of the groove in the door and new gaskets can be "pressed" back into place.

Drain Maintenance - Base

Each unit has a drain located inside the unit that removes the condensation from the evaporator coil and routes it to an external condensate evaporator pan. Each drain can become loose or disconnected during normal use. If you notice water accumulation on the inside of the unit be sure the drain tube is connected to the evaporator drain pan. If water is collecting underneath the unit make sure the end of the drain tube is in the condensate evaporator in the machine compartment. The leveling of the unit is important as the units are designed to drain properly when level. Be sure all drain lines are free of obstructions.

Caster Maintenance

Wipe casters with a damp cloth monthly to prevent corrosion.



The power switch must be turned to OFF and the unit disconnected from the power source whenever performing service, maintenance functions or cleaning the refrigerated area.

Refrigerators and Freezers

The interior and exterior can be cleaned using soap and warm water. If this isn't sufficient, try ammonia and water or a nonabrasive liquid cleaner. When cleaning the exterior, always rub with the "grain" of the stainless steel to avoid marring the finish. Do not use an abrasive cleaner because it will scratch the stainless steel and can damage the breaker strips and gaskets.

Stainless Steel Care and Cleaning

To prevent discoloration or rust on stainless steel several important steps need to be taken. First, we need to understand the properties of stainless steel. Stainless steel contains 70- 80% iron, which will rust. It also contains 12-30% chromium, which forms an invisible passive film over the steels surface, which acts as a shield against corrosion. As long as the protective layer is intact, the metal is still stainless. If the film is broken or contaminated, outside elements can begin to breakdown the steel and begin to form discoloration of rust. Proper cleaning of stainless steel requires soft cloths or plastic scouring pads.

NEVER USE STEEL PADS, WIRE BRUSHES OR SCRAPERS!

Cleaning solutions need to be alkaline based or non-chloride cleaners. Any cleaner containing chlorides will damage the protective film of the stainless steel. Chlorides are also commonly found in hard water, salts, and household and industrial cleaners. If cleaners containing chlorides are used be sure to rinse repeatedly and dry thoroughly. Routine cleaning of stainless steel can be done with soap and water. Extreme stains or grease should be cleaned with a non-abrasive cleaner and plastic scrub pad. Always rub with the grain of the steel. There are stainless steel cleaners available which can restore and preserve the finish of the steels protective layer. Early signs of stainless steel breakdown are small pits and cracks. If this has begun, clean thoroughly and start to apply stainless steel cleaners in attempt to restore the passivity of the steel.



Never use an acid based cleaning solution! Many food products have an acidic content, which can deteriorate the finish. Be sure to clean the stainless steel surfaces of ALL food products. Common items include, tomatoes, peppers and other vegetables.

Cleaning the Condenser Coil

In order to maintain proper refrigeration performance, the condenser fins must be cleaned of dust, dirt and grease regularly. It is recommended that this be done at least every three months. If conditions are such that the condenser is totally blocked in three months, the frequency of cleaning should be increased. Clean the condenser with a vacuum cleaner or stiff brush. If extremely dirty, a commercially available condenser cleaner may be required.

Failure to maintain a clean condenser coil can initially cause high temperatures and excessive run times. Continuous operation with a dirty or clogged condenser coil can result in compressor failure. Neglecting the condenser coil cleaning procedures will void any warranties associated with the compressor and cost to replace the compressor.



Never use a high-pressure water wash for this cleaning procedure as water can damage the electrical components located near or at the condenser coil.

Preventing blower coil corrosion

To help prevent corrosion of the blower coil, store all acidic items, such as pickles and tomatoes, in sealable containers. Immediately wipe up all spills.

Cleaning the condensate evaporator (remote models only)

The stainless steel condensate evaporator pan should be cleaned every six months. Use a vacuum cleaner or damp cloth to remove dust that may have accumulated. This will prevent corrosion of the stainless steel.

Defrosting

Milk or Ice Cream dispensers require defrosting after 3/8" to 1/2" of frost forming. On/Off switch is located above the louver panel.

Never use sharp objects or tools to clean or scrape ice/frost build up. A puncture could cause irreparable damage to the refrigeration system.

Cleaning the NLFAC milk dispensers

The following special instructions apply to the model NLFAC dispenser only. After cleaning the interior and exterior as described above, be sure to return the milk case loading tray to the bottom of the unit. The load tray is required not only for easy self-locating of milk cases, but it also ensures proper air flow through the evaporator coil for the air curtain.



Any restriction to the air flow path, including leaving the milk case load tray out of the cabinet, will result in the voiding of your warranties.

A drain is supplied to simplify cleaning of the interior. Open the clamp used to close off the drain tube. Drain accumulated liquid from the cabinet. Be sure to re-clamp the tubing before resuming operation of the NLFAC unit.

Air Diffuser Cleaning Procedure

The air diffuser is located on the inside wall by the evaporator fans. Remove the air diffuser from the equipment. Soak in fresh hot dishwater for five minutes. Rinse by spraying soap off with warm water, directing the spray into the holes. Repeat rinsing steps until material is visibly clean. Soak in sanitizing solution for five minutes. Replace into equipment.

Wiring Diagrams

Model — MFSC

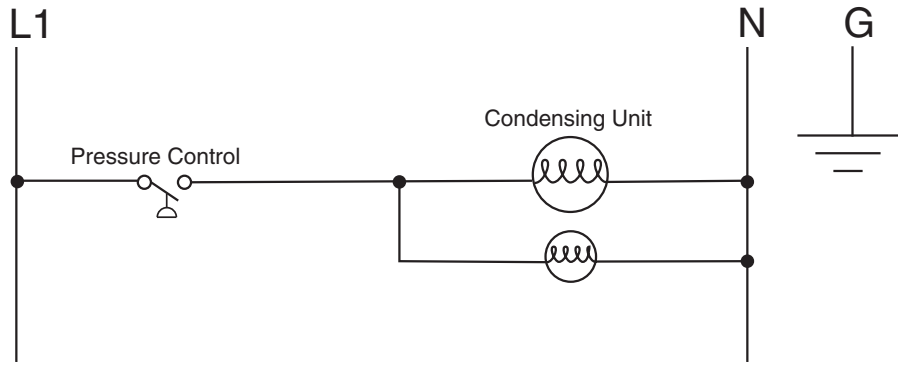

Models — N, SCF, NSCF, & NDF

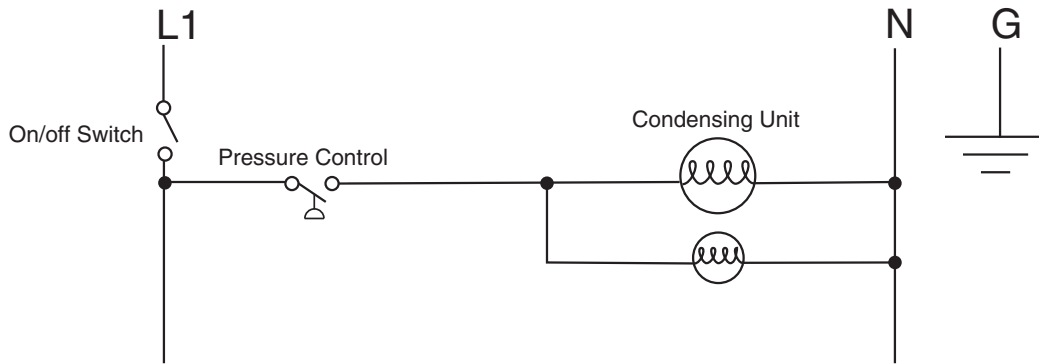

Model — NLFAC

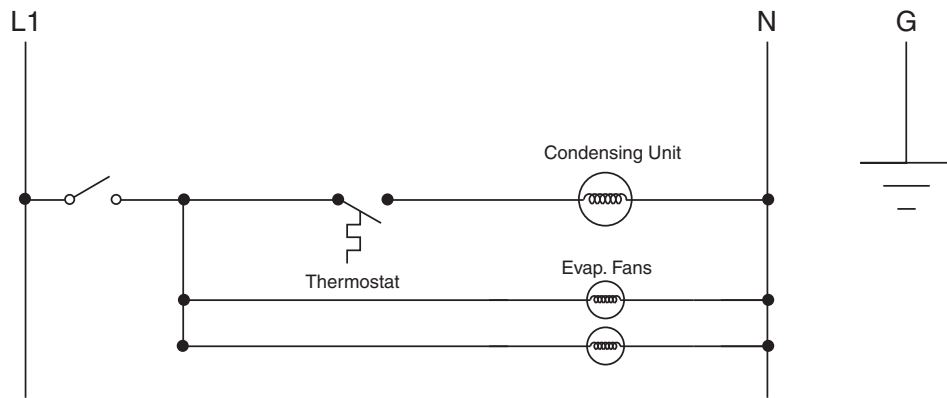

Replacement Parts

NLFAC8	
3516172	Blade, fan, evaporator
*377-AZ0-0004	Bolt, Lock
031-264-0000	Bracket, Evaporator Fan Motor
3234783	Caster, 5, Plate, Swivel, Break
3234156	Catch, Magnetic, Snap-In
3516065	Coil, Evaporator, 3.00" X 24.75"
AE630AT-602-J7	Compressor
3526675	Condensing Unit, 1/3HP, Hi, R134A
2183348	Cord, power, 16/3 W/Nema 5-15P
*000-BI7-0033	Cover assembly, NLFAC8
6230017	Hinge, aluminum in-between
6230020	Hinge, aluminum
6230110	Hinge, plastic insert
*271-BGF-0003	Divider, Milk Crate, NLFAC
3516101	Drier, Filter, 1/4ODF
3516173	Guard, Plastic, Fan
3234684	Lock Assembly, Glass Door
*359-411-0041	Louver, 13.00" X 25.00"
2162691	Motor, evaporator, 115V,50/60
2190154	Switch, Rocker, 20A/125V,
2194791	Thermometer Cable, Danfoss
2194792	Thermometer Display, Digital, Danfoss
000-282-0054	Thermostat control
6230007	Track, Door, 36.21, PVC, Black
3516062	Valve, Expansion, R134A
NLFAC12	
000-282-0054	Assembly, Control, Thermostat
3516172	Blade, fan, evaporator
*377-AZ0-0004	Bolt, Lock
031-264-0000	Bracket, Fan Motor
3234783	Caster, 5, Plate, Swivel, Break
3234156	Catch, Magnetic, Snap-In
3516065	Coil, Evaporator, 3.00 X 24.75
3527025	Compressor, AK168AT-038-J7, Tecumseh
3526688	Condensing Unit, 1/2HP, Hi, R134A
2183348	Cord, power, 16/3 W/Nema 5-15P
*000-BI7-0034	Cover Assembly, Lift, NLFAC-12
6230018	Hinge, aluminum in-between 24.0"
6230020	Hinge, Aluminum, Heavy Duty
6230110	Hinge, Insert, Plastic
*271-BGF-0003	Divider, Milk Crate, NLFAC

3516101	Drier, Filter, 1/4ODF
3516173	Guard, Plastic, Fan, 6"
3234684	Lock Assembly, Glass Door
*359-411-0041	Louver, 13.00 X 25.00
2162691	Motor, Fan, 115V, 50/60
2190154	Switch, Rocker, 20A/125V
2194791	Thermometer Cable, Danfoss
2194792	Thermometer Display, Digital, Danfoss
6230008	Track, Door, 50.21,PVC,BLACK
3516062	Valve, Expansion, R134A, RFG
NLFAC16	
000-282-0054	Assembly, Control, Thermostat
3516172	Blade, fan, evaporator
*377-AZ0-0004	Bolt, Lock
031-264-0000	Bracket, Fan Motor
3234783	Caster, 5, Plate, Swivel, Break
3234156	Catch, Magnetic, Snap-In
3516065	Coil, Evaporator, 3.00 X 24.75
3527024	Compressor, AK169AT-038-J7, Tecumseh
3526689	Condensing Unit, 1/2HP, Hi, R134A
2183348	Cord, power, 16/3 W/Nema 5-15P
*000-BI7-0035	Cover Assembly, Lift, NLFAC-16
6230019	Hinge, Aluminum, In Between
6230020	Hinge, Aluminum, Heavy Duty
6230110	Hinge, Insert, Plastic
*271-BGF-0003	Divider, Milk Crate, NLFAC
3516101	Drier, Filter, 1/4ODF
3516173	Guard, Plastic, Fan, 6"
3234684	Lock Assembly, Glass Door
*359-411-0041	Louver, 13.00 X 25.00
2162691	Motor, Fan, 115V, 50/60
2190154	Switch, Rocker, 20A/125V
2194791	Thermometer Cable, Danfoss
2194792	Thermometer Display, Digital, Danfoss
6230009	Track, Door, 64.21, PVC, Black
3516062	Valve, Expansion, R134A, RFG

* Part print on page 17.

** Condenser Assembly on page 15.

† Elevator Assembly on page 16.



Replacement Parts

N-520, 860, 1200 & 1530	
*265-774-0039	Carrier, elevator
AE540AT-238-J7	Compressor, Tecumseh
3526674	Condensing Unit, 1/4HP, Hi, R134A
2183348	Cord, power, 16/3 W/Nema 5-15P
*030-392-0030	Divider, Tray
3234065	Drain, 1" brass, 4" long, w/locknut and washer
6690493	Drain, Valve, 3/4 NPT
3516101	Drier, Filter, 1/4ODF
†000-546-0036	Elevator assembly, 12.6" High (on condensing unit side)
†000-546-0030	Elevator assembly, 24.41" High
3234110	Handle, lid, N-520/860/1200/1530
3234645	Leg, 6"
000-AYP-0037	Lid, sliding, bottom, N-520/860/1530
000-AYP-0038	Lid, sliding, bottom, N-1200/1530
000-AYP-0035	Lid, sliding, top, N-520/860
000-AYP-0036	Lid, sliding, top, N-1200/1530
3234105	Locknut/Washer, 1 Drain
*359-AZD-0000	Louver, 13.5" x 9"
*359-AZD-0001	Louver, 13.5" x 13"
*359-411-000C	Louver, 25" x 13"
2193927	Pressure control
2190154	Switch, Rocker, 20A/125V,
3516062	Valve, Expansion, R134A, RFG,

N6-N10-N14	
*265-774-003A	Carrier, N6, N10, N14
AE540AT-238-J7	Compressor - Tecumseh
3526674	Condensing Unit, 1/4HP, Hi, R134A
2183348	Cord, power, 16/3 W/Nema 5-15P
3234065	Drain, 1" brass, 4" long, w/ locknut and washer
6690493	Drain, Valve, 3/4" NPT
3516101	Drier, Filter, 1/4"ODF,
†000-546-0035	Elevator assembly, 22.57" high
3234110	Handle, lid, N6/10/14
3234645	Leg, 6"
000-AYP-0033	Lid Assembly, Bottom Sliding, N6
000-AYP-0034	Lid Assembly, Bottom Sliding, N10/14
000-AYP-0030	Lid Assembly, Top Sliding, N6

000-AYP-0031	Lid Assembly, Top Sliding, N10
000-AYP-0032	Lid Assembly, Top Sliding, N14
3234105	Locknut/Washer, 1" Drain
*359-AZD-0000	Louver, 13.5 x 9
*359-AZD-0001	Louver, 13.5 x 13
*359-411-000C	Louver, 25 x 13
2193927	Pressure control
2190154	Switch, Rocker, 20A/125V
3516062	Valve, Expansion, R134A, RFG

NDF-12	
6230170	Bumper, Corner, Small, PVC
3234180	Caster, 4, Plate, Swivel, Break
3234307	Catch, Door
AE540AT-238-J7	Compressor - Tecumseh
3526674	Condensing Unit, 1/4HP, Hi, R134A
2193927	Control, Pressure, Low
2183348	Cord, Lead, 16/3 W/Nema 5-15P
3234242	Drain, Plastic, 1IPS, 2.87
6690493	Drain, Valve, 3/4" NPT
3516101	Drier, Filter, 1/4"ODF
6700007	Gasket, Snap-In
000-BOV-0031	Hinge, Pin Assembly, Right Hand
000-BOV-0030	Hinge/Pin Assembly, Left Hand
000-BOM-0032	Lid Assembly, Front, NDF-12
000-BOM-0030	Lid Assembly, Top, NDF-12
6230003	Lock, Key, Lid, NDF/NDF A
*359-AZD-0030	Panel, Access, NDF-12
3516059	Thermometer, Digital
3516062	Valve, Expansion, R134A, RFG

* Part print on page 17.

** Condenser Assembly on page 15.

† Elevator Assembly on page 16.

Replacement Parts

NDF-18	
6230170	Bumper, Corner, Small, PVC
3234180	Caster, 4, Plate, Swivel, Break
3234307	Catch, Door
AE630AT-602-J7	Compressor
3526675	Condensing Unit, 1/3HP, Hi
2193927	Control, Pressure, Low
2183348	Cord, power, 16/3 W/Nema 5-15P
3234242	Drain, Plastic, 1IPS, 2.87
6690493	Drain, Valve, 3/4 NPT
3516101	Drier, Filter, 1/4ODF
6700008	Gasket, Snap-In
000-BOV-0031	Hinge, Pin Assembly, Right
000-BOV-0030	Hinge/Pin Assembly, Left
000-BOM-0033	Lid Assembly, Front, NDF-18
000-BOM-0031	Lid Assembly, Top, NDF-18
6230003	Lock, Key, Lid, NDF/NDFA
*359-AZD-0031	Panel, Access, NDF-18
3516059	Thermometer, Digital
3516062	Valve, Expansion, R134A, RFG

NSCF-48	
372-395-0000	Carrier, Large Ice Cream
**000-BN5-0030	Condensing Unit
2193927	Control, Pressure, Low
2183348	Cord, power, 16/3 W/Nema 5-15P
*030-392-0000	Divider, Shelley IC Tank
3234242	Drain, Plastic, 1IPS, 2.87
6690493	Drain, Valve, 3/4 NPT
†000-546-0030	Elevator Assembly, Small
3234645	Leg, 6", s/s
3234188	Lid
*359-411-0003	Louver, 25 x 13
*359-AZD-0001	Louver, Side, 13.00 X 13.50
*359-AZD-0000	Louver, Side, 9.00 X 13.50
2190154	Switch, Rocker, 20A/125V
3516273	Valve, Expansion, 1/4, Hi, R404a
3516225	Valve, Expansion, 1/4, Lo, R404a
*3516265	Valve, EPR, 3/8 ODF

SCF-32	
372-395-0000	Carrier, Large Ice Cream
**000-BN5-0030	Condensing Unit
2193927	Control, Pressure, Low
2183348	Cord, power, 16/3 W/Nema 5-15P
*030-392-0000	Divider, Shelley IC Tank
3234242	Drain, Plastic, 1IPS, 2.87
6690493	Drain, Valve, 3/4 NPT
†000-546-0030	Elevator Assembly, Small
3234645	Leg, 6", s/s
3234188	Lid
*359-411-0003	Louver, 25 x 13
*359-AZD-0001	Louver, Side, 13.00 X 13.50
*359-AZD-0000	Louver, Side, 9.00 X 13.50
2190154	Switch, Rocker, 20A/125V
3516225	Valve, Expansion, Freezer, 1/4Ton

SCF-48	
372-395-0000	Carrier, Large Ice Cream
**000-BN5-003G	Condensing Unit
2193927	Control, Pressure, Low
2183348	Cord, power, 16/3 W/Nema 5-15P
*030-392-0000	Divider, Shelley IC Tank
3234242	Drain, Plastic, 1IPS, 2.87
6690493	Drain, Valve, 3/4 NPT
†000-546-0030	Elevator Assembly, Small
3234645	Leg, 6", s/s
3234188	Lid
*359-411-0003	Louver, 25 x 13
*359-AZD-0001	Louver, Side, 13.00 X 13.50
*359-AZD-0000	Louver, Side, 9.00 X 13.50
2190154	Switch, Rocker, 20A/125V
3516225	Valve, Expansion, Freezer, 1/4Ton

* Part print on page 17.

** Condenser Assembly on page 15.

† Elevator Assembly on page 16.

Replacement Parts

MFSC-31, MFSC-44, MFSC-57, MFSC-2821	
372-395-0000	Carrier, ice cream
AE540AT-238-J7	Compressor, Tecumsh
3526674	Condensing Unit, 1/4HP, Hi, R134A
2193927	Control, Pressure, Low
2183348	Cord, power, 16/3 W/Nema 5-15P
1701278	Cover, expansion valve
*030-392-0000	Divider, Shelley IC Tank
3234242	Drain, Plastic, 1IPS, 2.87
3516101	Drier, Filter, 1/4ODF
†000-546-0030	Elevator Assembly, Small
3234188	Lid, Large, Ice Cream
*359-411-0003	Panel, Louvered, DropIn
3234021	Stopper, Drain, 1IPS
3516062	Valve, Expansion, R134A, RFG

MFSC-2020	
372-395-0038	Carrier, ice cream
AE540AT-238-J7	Compressor, Tecumsh
3526674	Condensing Unit, 1/4HP, Hi, R134A
2193927	Control, Pressure, Low
2183348	Cord, power, 16/3 W/Nema 5-15P
1701278	Cover, expansion valve
3234242	Drain, Plastic, 1IPS, 2.87
3516101	Drier, Filter, 1/4ODF
†000-546-003E	Elevator Assembly, Large
3234110	Handle, lid
000-BMN-0030	Lid, Assembly
*359-411-0003	Panel, Louvered, DropIn
3234021	Stopper, Drain, 1IPS
3516062	Valve, Expansion, R134A, RFG

MF-2821, MF-31, MF-44, MF-57	
6320007	Bearing, 0.50ID, 0.625OD
372-395-0000	Carrier
1701278	Cover, expansion valve
272-397-0030	Cover, top, elevator
*030-392-0000	Divider, Shelley IC Tank
3234242	Drain, Plastic, 1IPS, 2.87
†000-546-0030	Elevator Assembly, Small

MF-2020	
372-395-0038	Carrier
1701278	Cover, expansion valve
*030-392-0000	Divider, Shelley IC Tank
3234242	Drain, Plastic, 1IPS, 2.87
†000-546-0030	Elevator Assembly, Small
3234110	Handle, lid
000-BMN-0030	Lid assembly
3234021	Stopper, Drain, 1IPS
3516062	Valve, Expansion, R134A, RFG

* Part print on page 17.

** Condenser Assembly on page 15.

† Elevator Assembly on page 16.

Replacement Parts - Condensing Units

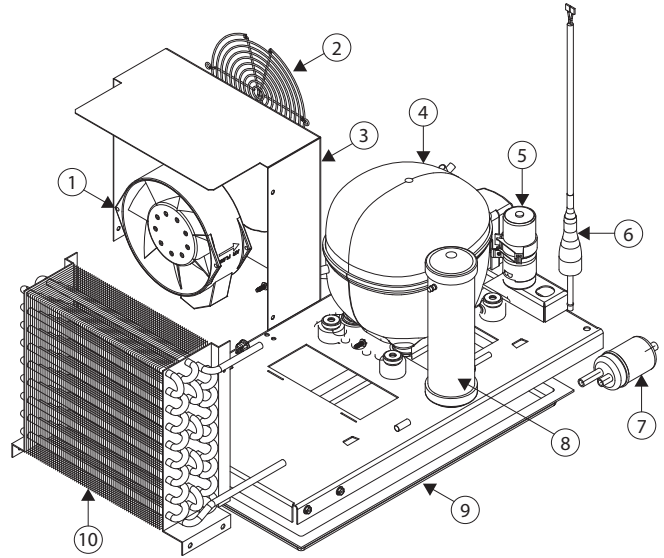
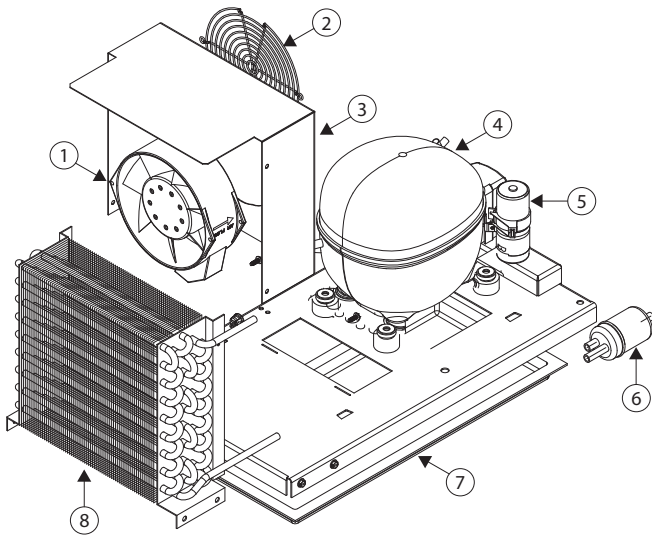

Condensing Unit		
Key	Part Number	Description
-	000-BN5-0030	Condensing Unit
1	2160028	Fan, Axial, 5.5", 120V
2	2160030	Guard, Fan, 6.0"
3	026-C58-0037	Shroud, condenser coil
4	3526999	Compressor, Danfoss, NF5.5CLX, 115V/60Z
5	2194787	Capacitor, start 280MFD
	3516444	Relay, overload, Danfoss, NF5.5CLX
6	3516322	Drier, filter
7	075-231-0030	Pan, condensate
8	3516454	Coil, Condenser

Condensing Unit		
Key	Part Number	Description
-	000-BN5-003G	Condensing Unit
1	2160028	Fan, Axial, 5.5", 120V
2	2160030	Guard, Fan, 6.0"
3	026-C58-0037	Shroud, condenser coil
4	3527000	Compressor, Danfoss, NF7CLS, 115V/60HZ
5	3516438	Relay, overload, Danfoss, NF7CLX
	2194788	Capacitor, start, 320MFD
6	3516324	High pressure cutout
7	3516322	Drier, filter
8	3516458	Receiver tank
8	075-231-0030	Pan, condensate
10	3516254	Coil, condenser

Replacement Parts - Elevator Assemblies

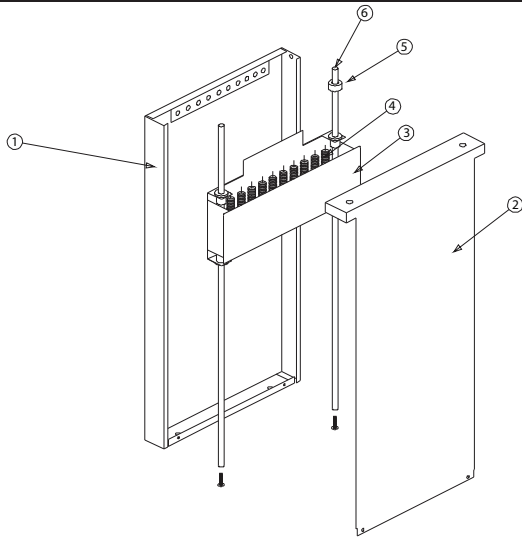
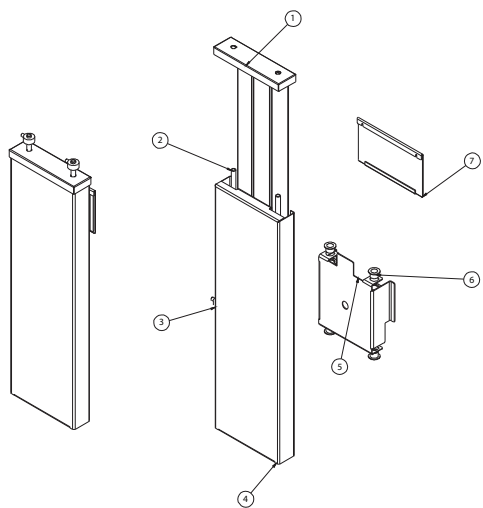

Elevator Assembly		
Key	Part Number	Description
-	000-546-0035	Elevator assembly, 22.57" high
1	272-397-0035	Cover, elevator
2	044-393-0035	Rod, guide
3	6230024	Retainer
4	372-398-0035	Body, elevator
5	264-394-0000	Carrier bracket, elevator
6	6320007	Bearing
7	264-396-0000	Carrier plate, elevator
-	6150201	Spring
Elevator Assembly		
-	000-546-0030	Elevator assembly, 24.41" High
1	272-397-0030	Cover, elevator
2	044-393-0030	Rod, guide, 25.43"
3	6230024	Retainer
4	372-398-0030	Body, elevator
5	264-394-0000	Carrier bracket, elevator
6	6320007	Bearing
7	264-396-0000	Carrier plate, elevator
-	6150201	Spring
Elevator Assembly		
-	000-546-0036	Elevator assembly, 12.6" High
1	272-397-0036	Cover, elevator
2	044-393-0036	Rod, guide, 13.62"
3	6230024	Retainer
4	372-398-0036	Body, elevator
5	264-394-0000	Carrier bracket, elevator
6	6320007	Bearing
7	264-396-0000	Carrier plate, elevator
-	6150201	Spring

Elevator Assembly		
-	000-546-003E	Elevator Assembly, Large
1	372-398-003e	Jacket elevator
2	221-397-003e	Cover, top, elevator
4	6150201	Spring, Extension
4	6150202	Spring, Extension
5	6230024	Retainer, Field Adj.
6	044-393-0030	Rod, Guide, Elevator, 25.43"
-	6320007	Bearing, 0.50"ID, 0.625"OD
-	264-394-0001	Elevator Carrier Plate
-	264-396-0001	Elevator Carrier Plate

Replacement Part Prints

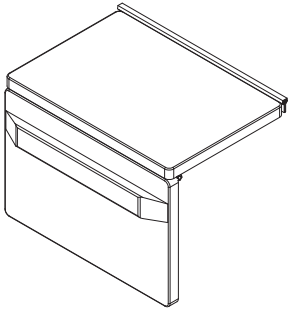

000-B17-0033 - Cover assembly, NLFAC8
 000-B17-0034 - Cover Assembly, Lift, NLFAC-12
 000-B17-0035 - Cover Assembly, Lift, NLFAC-16

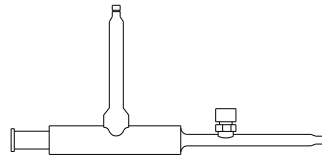

3516265 - Valve, EPR, 3/8 ODF

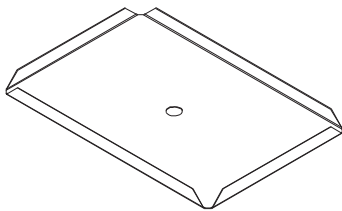

030-392-0000 - Divider, Shelley IC Tank
 030-392-0030 - Divider, Tray, MF, FF, RFF, SCF Series

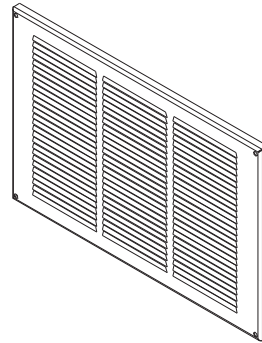

359-AZD-0000 - Louver, 13.5" x 9"
 359-AZD-0001 - Louver, 13.5" x 13"
 359-411-000C - Louver, 25" x 13", N-Series
 359-411-0003 - Louver, 25" x 13"

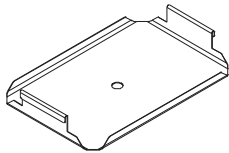

265-774-0039 - Carrier, elevator, N520, N860, N1200, N1530

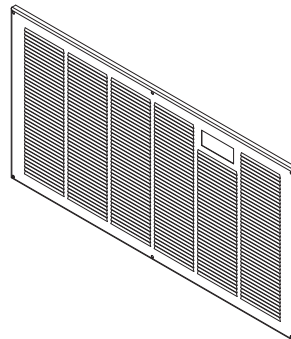

359-411-0041 - Louver, 13.00" X 25.00"

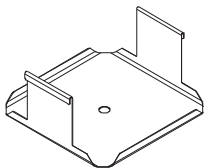

265-774-003A - Carrier, N6, N10, N14

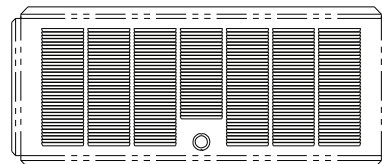

359-AZD-0030 - Panel, Access, NDF-12
 359-AZD-0031 - Panel, Access, NDF-18

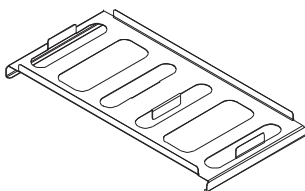

271-BGF-0003 - Divider, Milk Crate, NLFAC



377-AZ0-0004 - Bolt, Lock

Standard Labor Guidelines To Repair Or Replace Parts On Delfield Equipment

Advice and recommendations given by Delfield Service Technicians do not constitute or guarantee any special coverage.

- A maximum of 1-hour is allowed to **diagnose a defective component**.
- A maximum of 1-hour is allowed for **retrieval of parts** not in stock.
- A maximum **travel distance** of 100 miles round trip and 2-hours will be reimbursed.
- Overtime, installation/start-up, normal control adjustments, general maintenance, glass breakage, freight damage, and/or correcting and end-user installation error will not be reimbursed under warranty unless pre-approved with a **Service Work Authorization** from Delfield. You must submit the number with the service claim.

Labor Of 1 Hour Is Allowed To Replace:

- Compressor Start Components and Overload Protector
- Condensate Element
- Defrost Timer
- Door Hinges, Locks, and Gaskets
- Evaporator/Condenser Fan Motor and Blade
- Fan Delay/Defrost Termination Switch
- Hi-limit/Thermal Protector Switch
- Springs/Lowerator
- Thermometer
- Thermostat

Labor Of 2 Hours To Replace:

- Defrost Element
- Locate/Repair Leak
- Pressure Control

Labor Of 3 Hours To Replace:

- Condenser or Evaporator Coil
- Expansion Valve

Labor Of 4 Hours To Replace:

- Compressor

This includes recovery of refrigerant and leak check.

\$55.00 maximum reimbursement for refrigerant recovery (includes recovery machine, pump, torch, oil, flux, minor fittings, solder, brazing rod, nitrogen, or similar fees.)

Refrigerants:

- R134A A maximum of \$5.00/lb. or 31¢/oz. will be reimbursed.
- R404A A maximum of \$15.00/lb. or \$1.00/oz. will be reimbursed.

Notes





Mt. Pleasant, MI



Covington, TN

Thank you for choosing Delfield!

Help is a phone call away. Help our team of professional, courteous customer service reps by having your model number and serial number available at the time of your call (800) 733-8829.

Model: _____ S/N: _____

Installation Date: _____



For a list of Delfield's authorized parts depots, visit our website at www.delfield.com

Register your Delfield warranty online. Go to www.delfield.com under the service tab to complete.

