

SAFETY.CAT.COM™

SAFETY

Operation and Maintenance
Manual Excerpt



Operation and Maintenance Manual

725 and 730 Articulated Trucks

B1L1-Up (Machine)
B1M1-Up (Machine)

Important Safety Information

Most accidents that involve product operation, maintenance and repair are caused by failure to observe basic safety rules or precautions. An accident can often be avoided by recognizing potentially hazardous situations before an accident occurs. A person must be alert to potential hazards. This person should also have the necessary training, skills and tools to perform these functions properly.

Improper operation, lubrication, maintenance or repair of this product can be dangerous and could result in injury or death.

Do not operate or perform any lubrication, maintenance or repair on this product, until you have read and understood the operation, lubrication, maintenance and repair information.

Safety precautions and warnings are provided in this manual and on the product. If these hazard warnings are not heeded, bodily injury or death could occur to you or to other persons.

The hazards are identified by the "Safety Alert Symbol" and followed by a "Signal Word" such as "DANGER", "WARNING" or "CAUTION". The Safety Alert "WARNING" label is shown below.



The meaning of this safety alert symbol is as follows:

Attention! Become Alert! Your Safety is Involved.

The message that appears under the warning explains the hazard and can be either written or pictorially presented.

A non-exhaustive list of operations that may cause product damage are identified by "NOTICE" labels on the product and in this publication.

Caterpillar cannot anticipate every possible circumstance that might involve a potential hazard. The warnings in this publication and on the product are, therefore, not all inclusive. You must not use this product in any manner different from that considered by this manual without first satisfying yourself that you have considered all safety rules and precautions applicable to the operation of the product in the location of use, including site-specific rules and precautions applicable to the worksite. If a tool, procedure, work method or operating technique that is not specifically recommended by Caterpillar is used, you must satisfy yourself that it is safe for you and for others. You should also ensure that the product will not be damaged or become unsafe by the operation, lubrication, maintenance or repair procedures that you intend to use.

The information, specifications, and illustrations in this publication are on the basis of information that was available at the time that the publication was written. The specifications, torques, pressures, measurements, adjustments, illustrations, and other items can change at any time. These changes can affect the service that is given to the product. Obtain the complete and most current information before you start any job. Caterpillar dealers have the most current information available.



When replacement parts are required for this product Caterpillar recommends using Caterpillar replacement parts or parts with equivalent specifications including, but not limited to, physical dimensions, type, strength and material.

Failure to heed this warning can lead to premature failures, product damage, personal injury or death.

In the United States, the maintenance, replacement, or repair of the emission control devices and systems may be performed by any repair establishment or individual of the owner's choosing.

Safety Section

i02886436

Safety Messages

SMCS Code: 7000

There are several specific warning messages on this machine. The exact location of the hazards and the description of the hazards are reviewed in this section. Please become familiarized with all warning messages.

Make sure that all of the warning messages are legible. Clean the warning messages or replace the warning messages if you cannot read the words. Clean the warning messages or replace the warning messages if the illustrations are not legible. When you clean the warning messages, use a cloth, water and soap. Do not use solvent, gasoline, or other harsh chemicals to clean the warning messages. Solvent, gasoline, or harsh chemicals could loosen the adhesive that secures the warning message. Loose adhesive will cause the warning message to fall off the machine.

Replace any warning message that is damaged, or missing. If a warning message is attached to a part that is replaced, install a warning message on the replacement part. Any Caterpillar dealer can provide new warning messages.

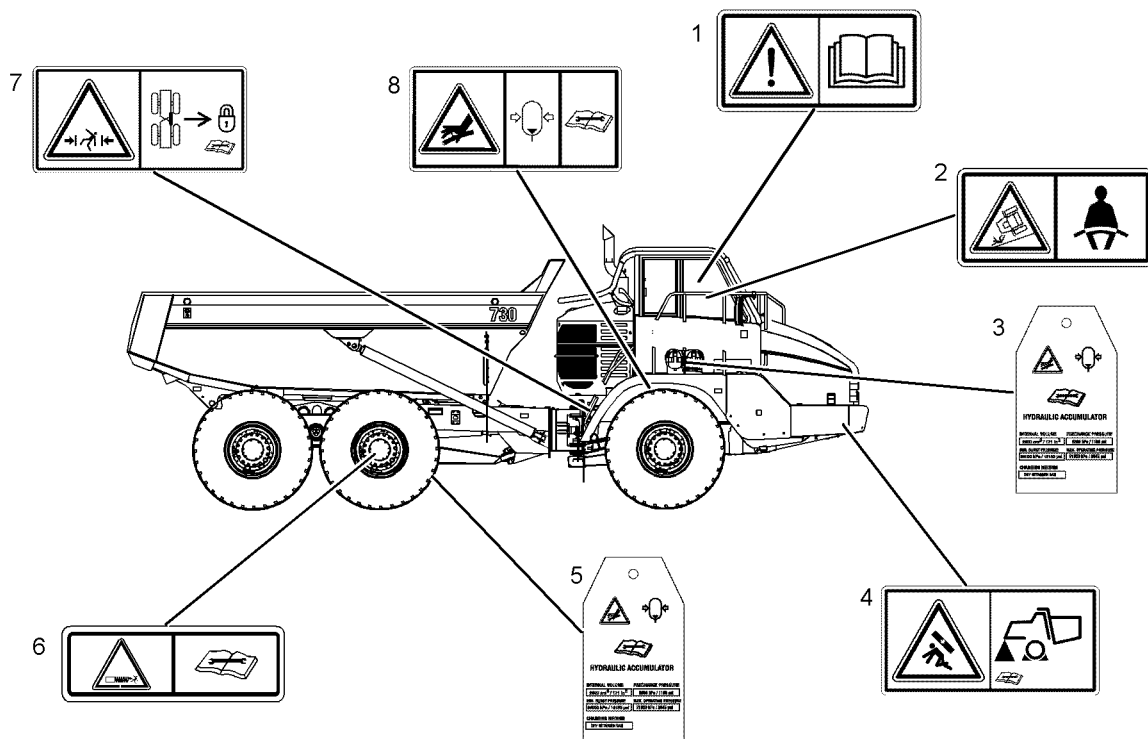

Illustration 2

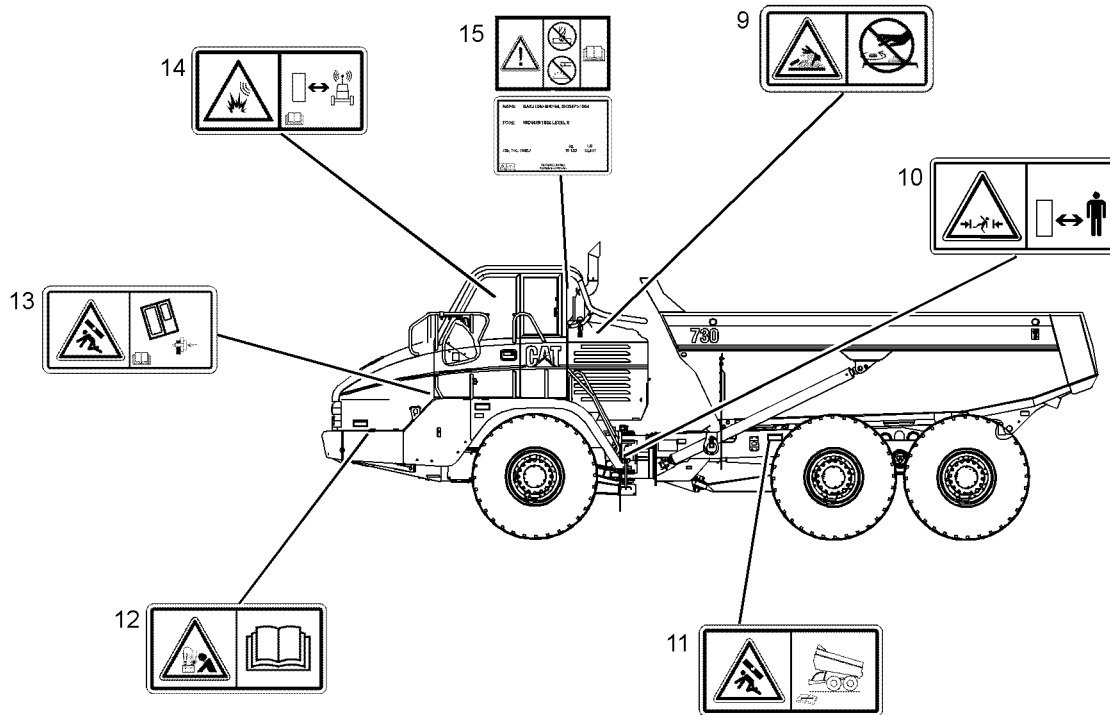

Illustration 3

g01436937

Do Not Operate (1)

This warning message is located in the cab.

Seat Belt (2)

This warning message is located in the cab.



g01370904

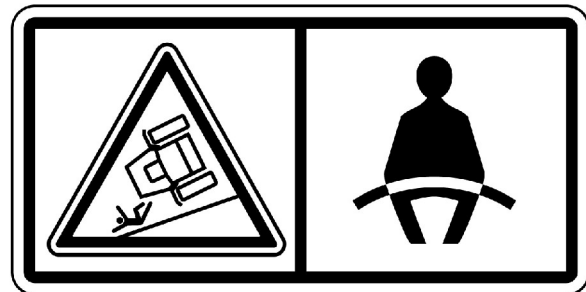

g01370908

⚠ WARNING

Do not operate or work on this machine unless you have read and understand the instructions and warnings in the Operation and Maintenance Manuals. Failure to follow the instructions or heed the warnings could result in injury or death. Contact any Caterpillar dealer for replacement manuals. Proper care is your responsibility.

⚠ WARNING

A seat belt should be worn at all times during machine operation to prevent serious injury or death in the event of an accident or machine overturn. Failure to wear a seat belt during machine operation may result in serious injury or death.

High Pressure Cylinders (3)

This warning message is located on both of the service brake accumulators. The service brake accumulators are located behind the right side panel of the cab.

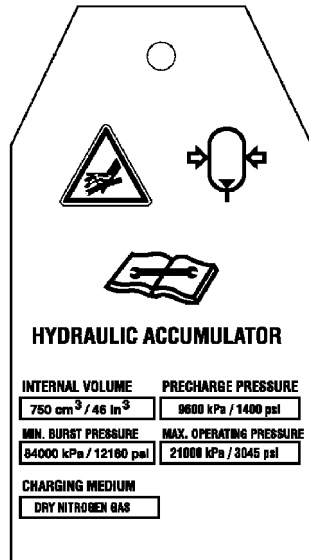

g01130902

WARNING

High pressure cylinder. Do not remove any parts until pressure has been relieved or personal injury may occur.

See your Caterpillar dealer for tools and detailed information required for charging cylinders.

Blocking the Machine (4)

This warning message is located above the front wheel on both sides of the machine.

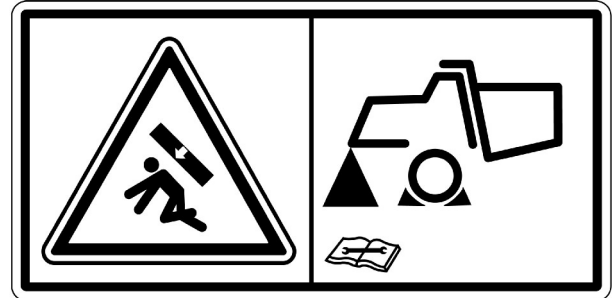

g01430344

WARNING

Personal injury or death by crushing can result from improper servicing procedures. The machine frame must be blocked and the pressure relieved before servicing. Failure to do so may cause serious injury or death. Read the Service Manual for the proper procedure.

High Pressure Cylinder (5)

This warning message is located on the parking brake accumulator. The parking brake accumulator is located on the right side of the rear frame.

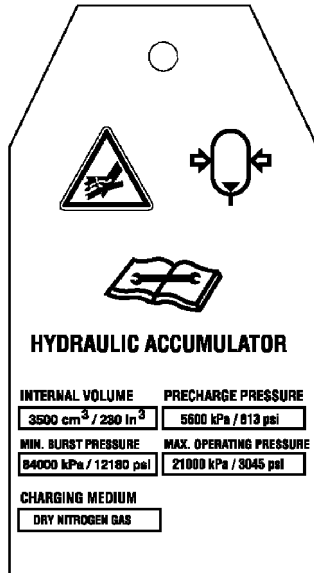

g01130903

WARNING

High pressure cylinder. Do not remove any parts until pressure has been relieved or personal injury may occur.

See your Caterpillar dealer for tools and detailed information required for charging cylinders.

High Compressed Spring (6)

This warning message is located on the brake actuator.

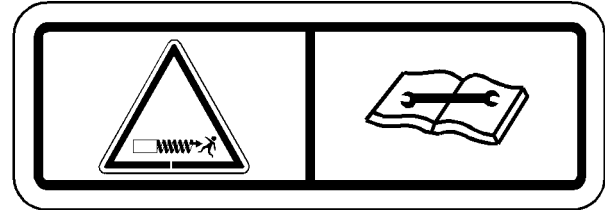

g01065910

WARNING

Personal injury or death can result from a compressed recoil spring being released suddenly using incorrect disassembly procedures.

A recoil spring that is still held in compression can result in the recoil spring being released unexpectedly with extreme force which could cause serious injury or death.

Make sure that the correct disassembly procedure is used, if a front track roller frame that has a crack in the parent metal or weld connection (or a tubular section that has separated from the front of the frame assembly) when the recoil spring is still held in compression.

Refer to Special Instruction, SMHS8273 which contains the disassembly procedure that must be used to decrease the possibility of injury while performing service on the track roller frame.

No Clearance (7)

This warning message is located on the fenders on both sides of the machine.

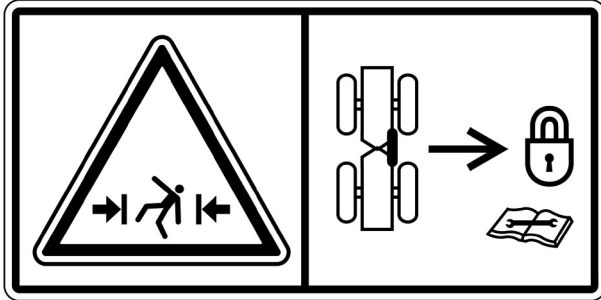

g01371647

WARNING

Connect the steering frame lock between the front and the rear frames before lifting, transporting, or servicing the machine in the articulation area. Disconnect the steering frame lock and secure the steering frame lock before resuming operation. Severe injury or death could occur.

Suspension Cylinder Strut (8)

This warning message is located on the suspension cylinder struts on both sides of the front of the machine.

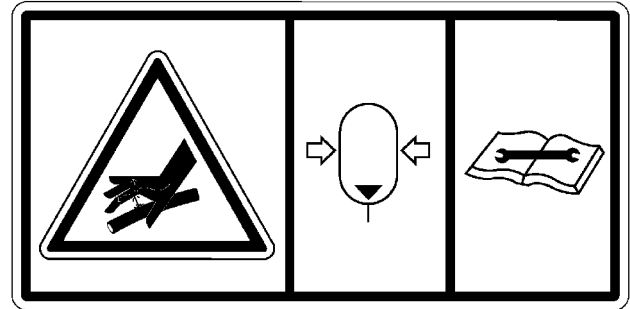

g01142855

WARNING

High Pressure Cylinder.

Do not remove any valve, hydraulic fitting, or valve core nor disassemble any cylinder parts until pressure is relieved. Personal injury or death may occur.

See service manual for correct procedure to relieve pressure and to charge cylinders.

Hot Coolant Under Pressure (9)

This warning message is located behind the operator compartment.



g01371640

! WARNING

The coolant is hot and the coolant is under pressure. Do not touch the hot surfaces. Refer to the Operation and Maintenance Manual for the procedure to follow when you check the radiator.

No Clearance (10)

This warning message is located on the fenders on both sides of the machine.

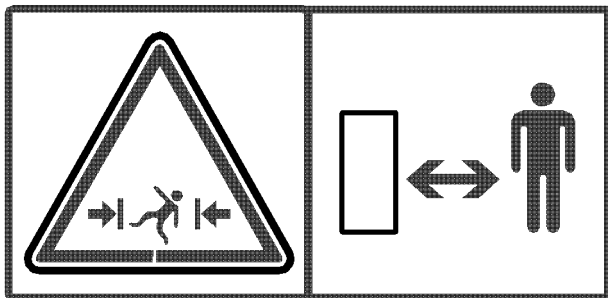

g01053243

! WARNING

Stay back a safe distance. No clearance for a person in this area when the machine turns. Severe injury or death from crushing could occur.

Body Prop (11)

This warning message is located on both sides of the rear frame.

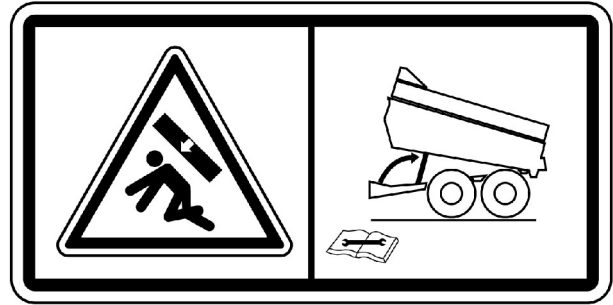

g01430347

! WARNING

Install dump body prop before working under a raised dump body to prevent it from falling which could result in personal injury or death.

Proper Connections for Jump Start Cables (12)

This warning message is located on the front side of the hood on both sides of the machine.

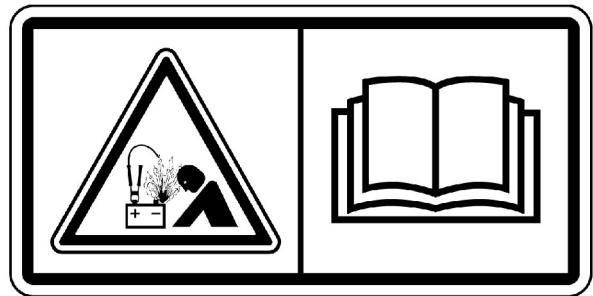

g01370909

! WARNING

Explosion Hazard! Improper jumper cable connections can cause an explosion resulting in serious injury or death. Batteries may be located in separate compartments. Refer to the Operation and Maintenance Manual for the correct jump starting procedure.

Prop for the Cab (13)

This warning message is located on the manual hand pump for tilting the cab.

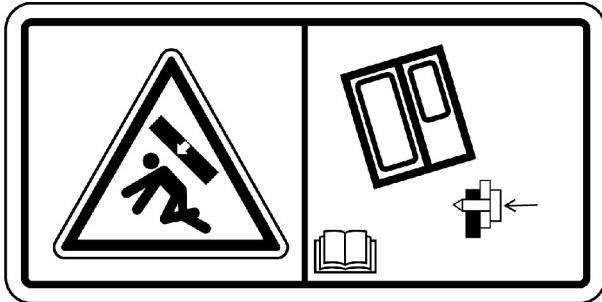

g01430342

WARNING

Install cab prop pin before working under raised cab to prevent it from falling which could result in injury or death.

Product Link (14)

If the machine is equipped with Product Link, this warning message is located in the cab.

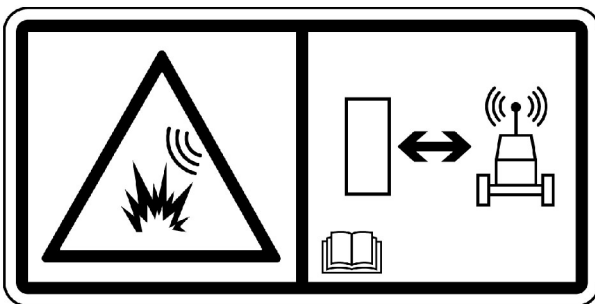

g01370917

WARNING

This machine is equipped with a Caterpillar Product Link communication device which must be deactivated within 12 m (40 ft) of a blast zone. Failure to do so could result in serious injury or death.

ROPS Certification (15)

This warning message is located on the back of the cab.

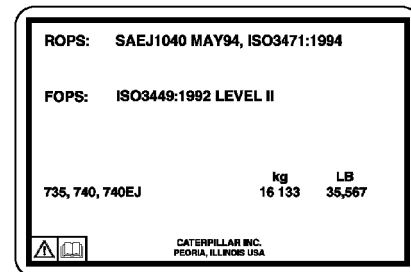
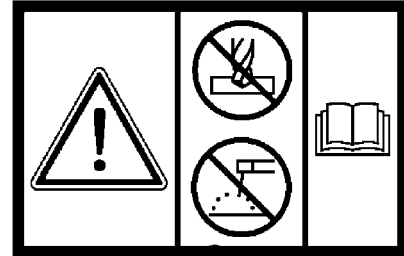

g01131392

WARNING

Structural damage, an overturn, modification, alteration, or improper repair can impair this structure's protection capability thereby voiding this certification. Do not weld on or drill holes in the structure. Consult a Caterpillar dealer to determine this structure's limitations without voiding its certification.

i02885514

Additional Messages

SMCS Code: 1000; 7000; 7405

There are several specific messages on these machines. The exact location of the messages and the description of the messages are reviewed in this section. Please become familiarized with all messages.

Make sure that all of the messages are legible. Clean the messages or replace the messages if the words or images are unreadable. When you clean the messages, use a cloth, water and soap. Do not use solvent, gasoline, or other harsh chemicals to clean the messages. Solvents, gasoline, or harsh chemicals could loosen the adhesive that secures the messages. Loose adhesive will allow the messages to fall.

Replace any message that is damaged, or missing. If a message is attached to a part that is replaced, install a message on the replacement part. Any Caterpillar dealer can provide new messages.

Retarding Guidelines

This message is located inside the cab.

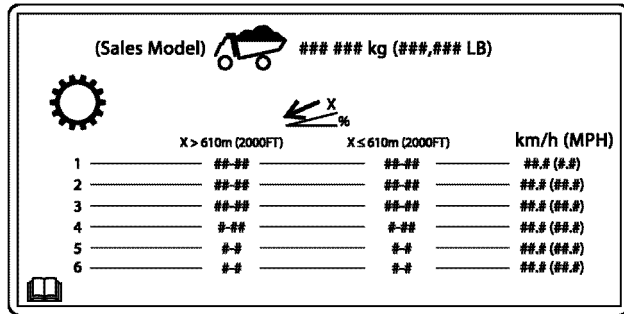

Illustration 4 g01319966
Typical example

Information for Air Conditioner System Service

This message is located inside the cab.

Do not work on the air conditioning system until you have read the service manual and you understand the service manual.

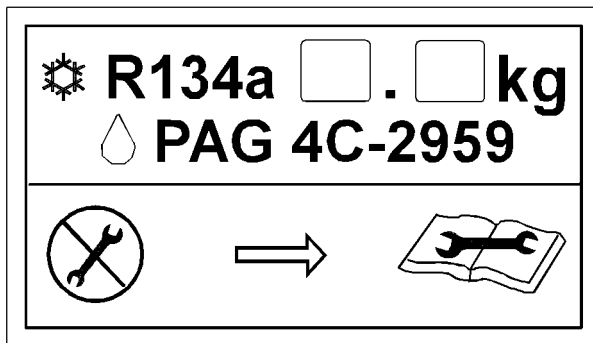

Illustration 5 g01294295

Product Link Data Privacy

This message is located in the cab.

The Product Link System is a satellite communication device that transmits information regarding the machine back to Caterpillar and Caterpillar dealers and customers. All logged events and diagnostic codes that are available to the Caterpillar Electronic Technician (ET) on the CAT data link can be sent to the satellite. Information can also be sent to the Product Link System. The information is used to improve Caterpillar products and Caterpillar services.

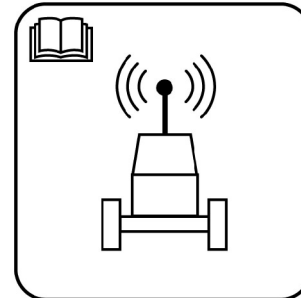

Illustration 6 g01418953

ELC (Extended Life Coolant) Cooling System

This message is located behind the cab near the cap for the cooling system.

This machine is shipped from the factory with ELC.

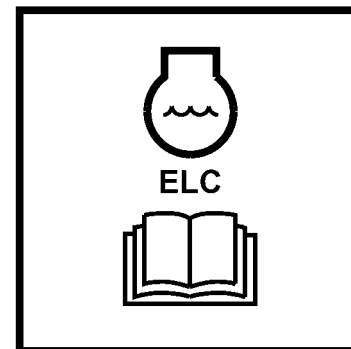

Illustration 7 g00955999

24 Volt Electrical System

This message is located near the batteries and the auxiliary start receptacle on the left front of the machine.

This machine is equipped with a 24 volt electrical system.

i03559343



Illustration 8

g01126478

Alternate Exit

This message is located on the right side rear cab window.

This film identifies an alternate exit. for more information on the alternate exit, refer to Operation and Maintenance Manual, "Alternate Exit".

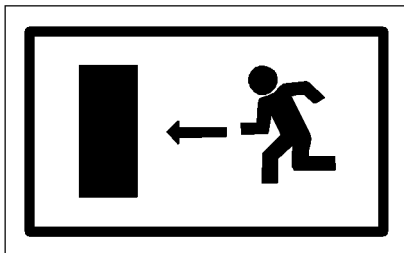

Illustration 9

g01002993

General Hazard Information

SMCS Code: 7000

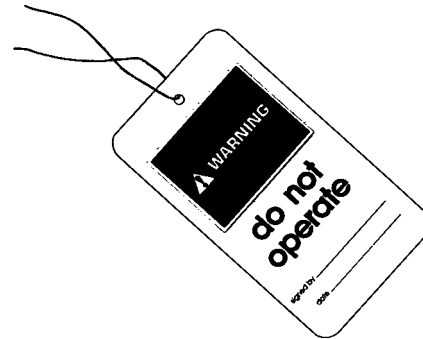

Illustration 10

g00104545

Attach a "Do Not Operate" warning tag or a similar warning tag to the start switch or to the controls before you service the equipment or before you repair the equipment. These warning tags (Special Instruction, SEHS7332) are available from your Caterpillar dealer.

Know the width of your equipment in order to maintain proper clearance when you operate the equipment near fences or near boundary obstacles.

Be aware of high voltage power lines and power cables that are buried. If the machine comes in contact with these hazards, serious injury or death may occur from electrocution.

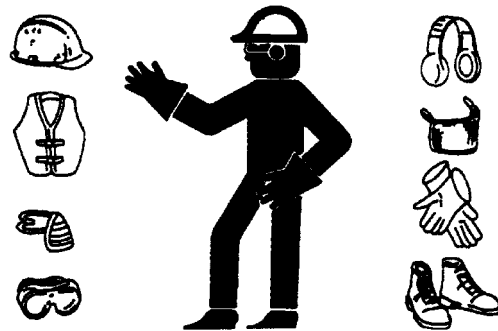

Illustration 11

g00702020

Wear a hard hat, protective glasses, and other protective equipment, as required.

Do not wear loose clothing or jewelry that can snag on controls or on other parts of the equipment.

Make sure that all protective guards and all covers are secured in place on the equipment.

Keep the equipment free from foreign material. Remove debris, oil, tools, and other items from the deck, from walkways, and from steps.

Secure all loose items such as lunch boxes, tools, and other items that are not a part of the equipment.

Know the appropriate work site hand signals and the personnel that are authorized to give the hand signals. Accept hand signals from one person only.

Do not smoke when you service an air conditioner. Also, do not smoke if refrigerant gas may be present. Inhaling the fumes that are released from a flame that contacts air conditioner refrigerant can cause bodily harm or death. Inhaling gas from air conditioner refrigerant through a lighted cigarette can cause bodily harm or death.

Never put maintenance fluids into glass containers. Drain all liquids into a suitable container.

Obey all local regulations for the disposal of liquids.

Use all cleaning solutions with care. Report all necessary repairs.

Do not allow unauthorized personnel on the equipment.

Unless you are instructed otherwise, perform maintenance with the equipment in the servicing position. Refer to Operation and Maintenance Manual for the procedure for placing the equipment in the servicing position.

When you perform maintenance above ground level use appropriate devices such as ladders or man lift machines. If equipped, use the machine anchorage points and use approved fall arrest harnesses and lanyards.

Pressurized Air and Water

Pressurized air and/or water can cause debris and/or hot water to be blown out. This could result in personal injury.

When pressurized air and/or pressurized water is used for cleaning, wear protective clothing, protective shoes, and eye protection. Eye protection includes goggles or a protective face shield.

The maximum air pressure for cleaning purposes must be reduced to 205 kPa (30 psi) when the nozzle is deadheaded and the nozzle is used with an effective chip deflector and personal protective equipment. The maximum water pressure for cleaning purposes must be below 275 kPa (40 psi).

Trapped Pressure

Pressure can be trapped in a hydraulic system. Releasing trapped pressure can cause sudden machine movement or attachment movement. Use caution if you disconnect hydraulic lines or fittings. High pressure oil that is released can cause a hose to whip. High pressure oil that is released can cause oil to spray. Fluid penetration can cause serious injury and possible death.

Fluid Penetration

Pressure can be trapped in the hydraulic circuit long after the engine has been stopped. The pressure can cause hydraulic fluid or items such as pipe plugs to escape rapidly if the pressure is not relieved correctly.

Do not remove any hydraulic components or parts until pressure has been relieved or personal injury may occur. Do not disassemble any hydraulic components or parts until pressure has been relieved or personal injury may occur. Refer to the Service Manual for any procedures that are required to relieve the hydraulic pressure.

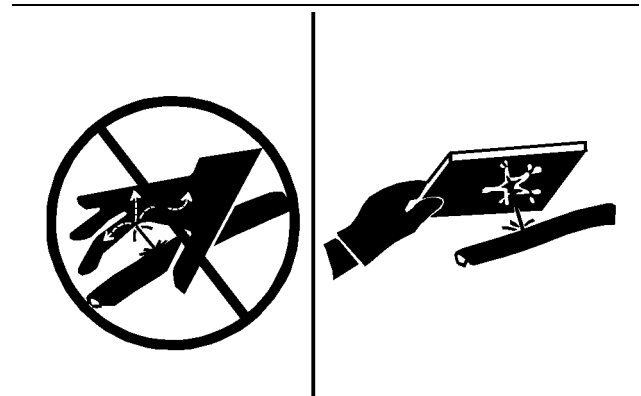

Illustration 12

g00687600

Always use a board or cardboard when you check for a leak. Leaking fluid that is under pressure can penetrate body tissue. Fluid penetration can cause serious injury and possible death. A pin hole leak can cause severe injury. If fluid is injected into your skin, you must get treatment immediately. Seek treatment from a doctor that is familiar with this type of injury.

Containing Fluid Spillage

Care must be taken in order to ensure that fluids are contained during performance of inspection, maintenance, testing, adjusting and repair of the equipment. Prepare to collect the fluid with suitable containers before opening any compartment or disassembling any component that contains fluids.

Refer to Special Publication, NENG2500, "Caterpillar Dealer Service Tool Catalog" for the following items:

- Tools that are suitable for collecting fluids and equipment that is suitable for collecting fluids
- Tools that are suitable for containing fluids and equipment that is suitable for containing fluids

Obey all local regulations for the disposal of liquids.

Asbestos Information

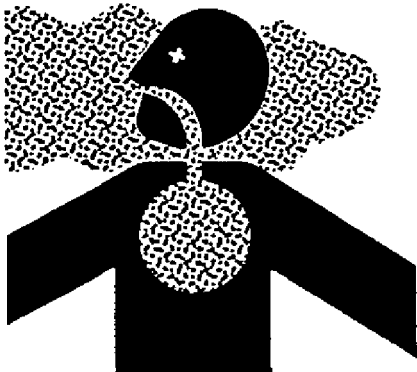

Illustration 13

g00702022

Caterpillar equipment and replacement parts that are shipped from Caterpillar are asbestos free. Caterpillar recommends the use of only genuine Caterpillar replacement parts. Use the following guidelines when you handle any replacement parts that contain asbestos or when you handle asbestos debris.

Use caution. Avoid inhaling dust that might be generated when you handle components that contain asbestos fibers. Inhaling this dust can be hazardous to your health. The components that may contain asbestos fibers are brake pads, brake bands, lining material, clutch plates, and some gaskets. The asbestos that is used in these components is usually bound in a resin or sealed in some way. Normal handling is not hazardous unless airborne dust that contains asbestos is generated.

If dust that may contain asbestos is present, there are several guidelines that should be followed:

- Never use compressed air for cleaning.
- Avoid brushing materials that contain asbestos.
- Avoid grinding materials that contain asbestos.
- Use a wet method in order to clean up asbestos materials.
- A vacuum cleaner that is equipped with a high efficiency particulate air filter (HEPA) can also be used.

- Use exhaust ventilation on permanent machining jobs.
- Wear an approved respirator if there is no other way to control the dust.
- Comply with applicable rules and regulations for the work place. In the United States, use Occupational Safety and Health Administration (OSHA) requirements. These OSHA requirements can be found in "29 CFR 1910.1001".
- Obey environmental regulations for the disposal of asbestos.
- Stay away from areas that might have asbestos particles in the air.

Dispose of Waste Properly

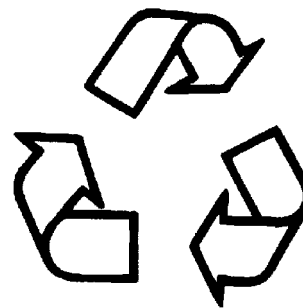

Illustration 14

g00706404

Improperly disposing of waste can threaten the environment. Potentially harmful fluids should be disposed of according to local regulations.

Always use leakproof containers when you drain fluids. Do not pour waste onto the ground, down a drain, or into any source of water.

i01359664

Crushing Prevention and Cutting Prevention

SMCS Code: 7000

Support the equipment properly before you perform any work or maintenance beneath that equipment. Do not depend on the hydraulic cylinders to hold up the equipment. Equipment can fall if a control is moved, or if a hydraulic line breaks.

Do not work beneath the cab of the machine unless the cab is properly supported.

Unless you are instructed otherwise, never attempt adjustments while the machine is moving or while the engine is running.

Never jump across the starter solenoid terminals in order to start the engine. Unexpected machine movement could result.

Whenever there are equipment control linkages the clearance in the linkage area will change with the movement of the equipment or the machine. Stay clear of areas that may have a sudden change in clearance with machine movement or equipment movement.

Stay clear of all rotating and moving parts.

If it is necessary to remove guards in order to perform maintenance, always install the guards after the maintenance is performed.

Keep objects away from moving fan blades. The fan blade will throw objects or cut objects.

Do not use a kinked wire cable or a frayed wire cable. Wear gloves when you handle wire cable.

When you strike a retainer pin with force, the retainer pin can fly out. The loose retainer pin can injure personnel. Make sure that the area is clear of people when you strike a retainer pin. To avoid injury to your eyes, wear protective glasses when you strike a retainer pin.

Chips or other debris can fly off an object when you strike the object. Make sure that no one can be injured by flying debris before striking any object.

i01329099

Burn Prevention

SMCS Code: 7000

Do not touch any part of an operating engine. Allow the engine to cool before any maintenance is performed on the engine. Relieve all pressure in the air system, in the oil system, in the lubrication system, in the fuel system, or in the cooling system before any lines, fittings or related items are disconnected.

Coolant

When the engine is at operating temperature, the engine coolant is hot. The coolant is also under pressure. The radiator and all lines to the heaters or to the engine contain hot coolant.

Any contact with hot coolant or with steam can cause severe burns. Allow cooling system components to cool before the cooling system is drained.

Check the coolant level only after the engine has been stopped.

Ensure that the filler cap is cool before removing the filler cap. The filler cap must be cool enough to touch with a bare hand. Remove the filler cap slowly in order to relieve pressure.

Cooling system conditioner contains alkali. Alkali can cause personal injury. Do not allow alkali to contact the skin, the eyes, or the mouth.

Oils

Hot oil and hot components can cause personal injury. Do not allow hot oil to contact the skin. Also, do not allow hot components to contact the skin.

Remove the hydraulic tank filler cap only after the engine has been stopped. The filler cap must be cool enough to touch with a bare hand. Follow the standard procedure in this manual in order to remove the hydraulic tank filler cap.

Batteries

Electrolyte is an acid. Electrolyte can cause personal injury. Do not allow electrolyte to contact the skin or the eyes. Always wear protective glasses for servicing batteries. Wash hands after touching the batteries and connectors. Use of gloves is recommended.

i03659986

Fire Prevention and Explosion Prevention

SMCS Code: 7000



Illustration 15

g00704000

General

All fuels, most lubricants, and some coolant mixtures are flammable.

To minimize the risk of fire or explosion, Caterpillar recommends the following actions.

Always perform a Walk-Around Inspection, which may help you identify a fire hazard. Do not operate a machine when a fire hazard exists. Contact your Caterpillar dealer for service.

Understand the use of the primary exit and alternative exit on the machine. Refer to Operation and Maintenance Manual, "Alternative Exit".

Do not operate a machine with a fluid leak. Repair leaks and clean up fluids before resuming machine operation. Fluids that are leaking or spilled onto hot surfaces or onto electrical components can cause a fire. A fire may cause personal injury or death.

Remove flammable material such as leaves, twigs, papers, trash, etc. These items may accumulate in the engine compartment or around other hot areas and hot parts on the machine.

Keep the access doors to major machine compartments closed and access doors in working condition in order to permit the use of fire suppression equipment, in case a fire should occur.

Clean all accumulations of flammable materials such as fuel, oil and debris from the machine.

Do not operate the machine near any flame.

Keep shields in place. Exhaust shields (if equipped) protect hot exhaust components from oil spray or fuel spray in case of a break in a line, in a hose, or in a seal. Exhaust shields must be installed correctly.

Do not weld or flame cut on tanks or lines that contain flammable fluids or flammable material. Empty and purge the lines and tanks. Then clean the lines and tanks with a nonflammable solvent prior to welding or flame cutting. Ensure that the components are properly grounded in order to avoid unwanted arcs.

Dust that is generated from repairing nonmetallic hoods or fenders may be flammable and/or explosive. Repair such components in a well ventilated area away from open flames or sparks. Use suitable Personal Protection Equipment (PPE).

Inspect all lines and hoses for wear or deterioration. Replace damaged lines and hoses. The lines and the hoses should have adequate support and secure clamps. Tighten all connections to the recommended torque. Damage to the protective cover or insulation may provide fuel for fires.

Store fuels and lubricants in properly marked containers away from unauthorized personnel. Store oily rags and flammable materials in protective containers. Do not smoke in areas that are used for storing flammable materials.



Illustration 16

g00704059

Use caution when you are fueling a machine. Do not smoke while you are fueling a machine. Do not fuel a machine near open flames or sparks. Always stop the engine before fueling. Fill the fuel tank outdoors. Properly clean areas of spillage.

Follow practices for safe fueling that are described in the "Operation" section of the Operation and Maintenance Manual section and follow local regulations. Never store flammable fluids in the operator compartment of the machine.

Battery and Battery Cables

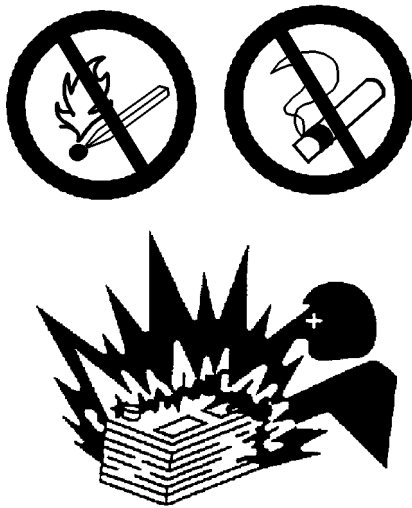

Illustration 17

g00704135

Caterpillar recommends the following in order to minimize the risk of fire or an explosion related to the battery.

Do not operate a machine if battery cables or related parts show signs of wear or damage. Contact your Caterpillar dealer for service.

Follow safe procedures for engine starting with jump start cables. Improper jumper cable connections can cause an explosion that may result in injury. Refer to Operation and Maintenance Manual, "Engine Starting with Jump Start Cables" for specific instructions.

Do not charge a frozen battery. This may cause an explosion.

Gases from a battery can explode. Keep any open flames or sparks away from the top of a battery. Do not smoke in battery charging areas.

Never check the battery charge by placing a metal object across the terminal posts. Use a voltmeter in order to check the battery charge.

Daily inspect battery cables that are in areas that are visible. Inspect cables, clips, straps, and other restraints for damage. Replace any damaged parts. Check for signs of the following, which can occur over time due to use and environmental factors:

- Fraying
- Abrasion
- Cracking

- Discoloration
- Cuts on the insulation of the cable
- Fouling
- Corroded terminals, damaged terminals, and loose terminals

Replace damaged battery cable(s) and replace any related parts. Eliminate any fouling, which may have caused insulation failure or related component damage or wear. Ensure that all components are reinstalled correctly.

An exposed wire on the battery cable may cause a short to ground if the exposed area comes into contact with a grounded surface. A battery cable short produces heat from the battery current, which may be a fire hazard.

An exposed wire on the ground cable between the battery and the disconnect switch may cause the disconnect switch to be bypassed if the exposed area comes into contact with a grounded surface. This may result in an unsafe condition for servicing the machine. Repair components or replace components before servicing the machine.

WARNING

Fire on a machine can result in personal injury or death. Exposed battery cables that come into contact with a grounded connection can result in fires. Replace cables and related parts that show signs of wear or damage. Contact your Caterpillar dealer.

Wiring

Check electrical wires daily. If any of the following conditions exist, replace parts before you operate the machine.

- Fraying
- Signs of abrasion or wear
- Cracking
- Discoloration
- Cuts on insulation
- Other damage

Make sure that all clamps, guards, clips, and straps are reinstalled correctly. This will help to prevent vibration, rubbing against other parts, and excessive heat during machine operation.

Attaching electrical wiring to hoses and tubes that contain flammable fluids or combustible fluids should be avoided.

Consult your Caterpillar dealer for repair or for replacement parts.

Keep wiring and electrical connections free of debris.

Lines, Tubes and Hoses

Do not bend high pressure lines. Do not strike high pressure lines. Do not install any lines that are bent or damaged. Use the appropriate backup wrenches in order to tighten all connections to the recommended torque.

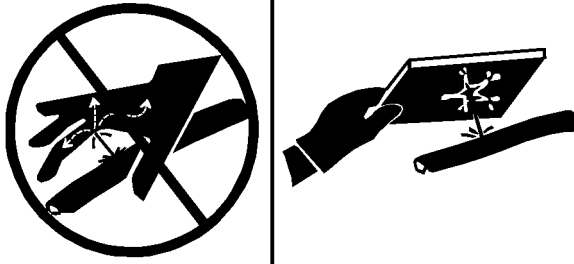

Illustration 18

g00687600

Check lines, tubes and hoses carefully. Wear Personal Protection Equipment (PPE) in order to check for leaks. Always use a board or cardboard when you check for a leak. Leaking fluid that is under pressure can penetrate body tissue. Fluid penetration can cause serious injury and possible death. A pin hole leak can cause severe injury. If fluid is injected into your skin, you must get treatment immediately. Seek treatment from a doctor that is familiar with this type of injury.

Replace the affected parts if any of the following conditions are present:

- End fittings are damaged or leaking.
- Outer coverings are chafed or cut.
- Wires are exposed.
- Outer coverings are swelling or ballooning.
- Flexible parts of the hoses are kinked.
- Outer covers have exposed embedded armoring.
- End fittings are displaced.

Make sure that all clamps, guards, and heat shields are installed correctly. During machine operation, this will help to prevent vibration, rubbing against other parts, excessive heat, and failure of lines, tubes and hoses.

Do not operate a machine when a fire hazard exists. Repair any lines that are corroded, loose or damaged. Leaks may provide fuel for fires. Consult your Caterpillar dealer for repair or for replacement parts. Use genuine Caterpillar parts or the equivalent, for capabilities of both the pressure limit and temperature limit.

Ether

Ether (if equipped) is commonly used in cold weather applications. Ether is flammable and poisonous.

Follow the correct cold engine starting procedures. Refer to the section in the Operation and Maintenance Manual with the label "Engine Starting".

Do not spray ether manually into an engine if the machine is equipped with a thermal starting aid for cold weather starting.

Use ether in well ventilated areas. Do not smoke while you are replacing an ether cylinder or while you are using an ether spray.

Do not store ether cylinders in living areas or in the operator compartment of a machine. Do not store ether cylinders in direct sunlight or in temperatures above 49° C (120.2° F). Keep ether cylinders away from open flames or sparks.

Dispose of used ether cylinders properly. Do not puncture an ether cylinder. Keep ether cylinders away from unauthorized personnel.

Fire Extinguisher

As an additional safety measure, keep a fire extinguisher on the machine.

Be familiar with the operation of the fire extinguisher. Inspect the fire extinguisher and service the fire extinguisher regularly. Follow the recommendations on the instruction plate.

Consider installation of an aftermarket Fire Suppression System, if the application and working conditions warrant the installation.

i01392300

Fire Extinguisher Location

SMCS Code: 7000

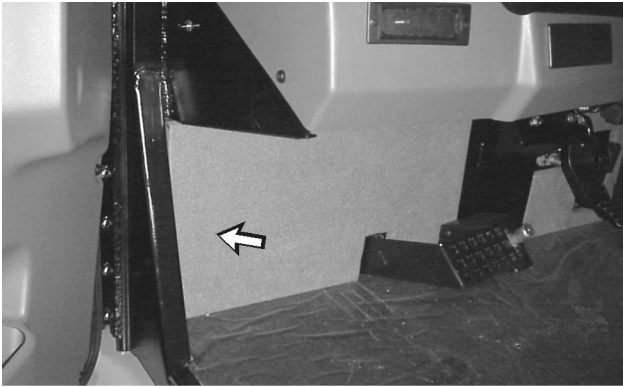

Illustration 19

g00735725

The fire extinguisher must be mounted in the cab. Mount the fire extinguisher on the front wall of the cab under the dash on the left side next to the door.

Do not mount the fire extinguisher on the ROPS.

The fire extinguisher mounting must be capable of withstanding a force that is equivalent to twenty times the effect of gravity.

i01557411

Tire Information

SMCS Code: 7000

Explosions of air inflated tires have resulted from heat-induced gas combustion inside the tires. Explosions can be caused by heat that is generated by welding, by heating rim components, by external fire, or by excessive use of brakes.

A tire explosion is much more violent than a blowout. The explosion can propel the tire, the rim components, and the axle components as far as 500 m (1500 ft) or more from the machine. Both the force of the explosion and the flying debris can cause property damage, personal injury, or death.

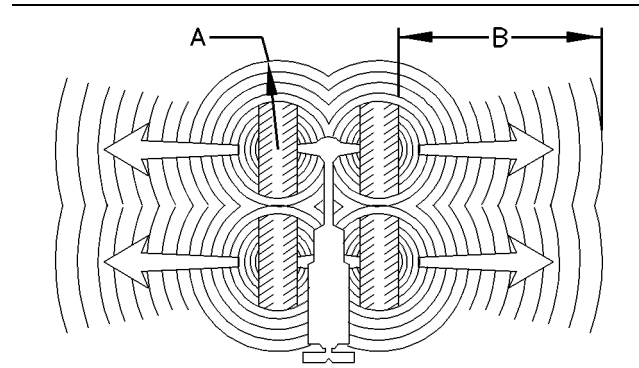

Illustration 20

g00337832

(A) At least 15 m (50 ft)
(B) At least 500 m (1500 ft)

Do not approach a warm tire. Maintain a minimum distance, as shown. Stay outside the shaded area in Illustration 20.

Do not use water or calcium as a ballast for the tires. Dry nitrogen gas is recommended for inflation of tires. If the tires were originally inflated with air, nitrogen is still preferred for adjusting the pressure. Nitrogen mixes properly with air.

Nitrogen inflated tires reduce the potential of a tire explosion because nitrogen does not aid combustion. Nitrogen helps to prevent oxidation of the rubber, deterioration of rubber, and corrosion of rim components.

To avoid overinflation, proper nitrogen inflation equipment and training in the usage of the equipment are necessary. A tire blowout or a rim failure can result from improper equipment or from misused equipment.

When you inflate a tire, stand behind the tread and use a self-attaching chuck.

Servicing tires and rims can be dangerous. Only trained personnel that use proper tools and proper procedures should perform this maintenance. If correct procedures are not used for servicing tires and rims, the assemblies could burst with explosive force. This explosive force can cause serious personal injury or death. Carefully obey the specific instructions from your tire dealer.

i01122596

i01995114

Electrical Storm Injury Prevention

SMCS Code: 7000

When lightning is striking in the vicinity of the machine, the operator should never attempt the following procedures:

- Mount the machine.
- Dismount the machine.

If you are in the operator's station during an electrical storm, stay in the operator's station. If you are on the ground during an electrical storm, stay away from the vicinity of the machine.

i01519849

Before Starting Engine

SMCS Code: 1000; 7000

The steering frame lock must be stored in the proper location for normal operation of the machine. Each steering frame lock must be removed in order to articulate the machine.

Start the engine only from the operator's compartment. Never short across the starter terminals or across the batteries. Shorting could bypass the engine neutral start system. Shorting could also damage the electrical system.

Inspect the condition of the seat belt and the condition of the mounting hardware. Replace any damaged parts and any worn parts. Regardless of appearance, replace the seat belt after three years of use. Do not use a seat belt extension on a retractable seat belt.

Adjust the seat so that full pedal travel can be achieved. The back of the operator must be in contact with the back of the seat. Adjust the steering column.

Make sure that the machine is equipped with a lighting system that is adequate for the job conditions. Make sure that all lights are working properly.

Before you start the engine or before you move the machine, make sure that no one is on the machine, underneath the machine, or around the machine. Make sure that there are no personnel in the area.

Engine Starting

SMCS Code: 1000; 7000

If a warning tag is attached to the engine start switch or to the controls, do not start the engine. Also, do not move any controls.

Move the hoist control to the HOLD position before you start the engine.

Move the transmission control to the N position before you start the engine.

Move the parking brake control to the ENGAGED position before you start the engine.

Diesel engine exhaust contains products of combustion which can be harmful to your health. Always start the engine in a well ventilated area. Always operate the machine in a well ventilated area. If you are in an enclosed area, vent the exhaust to the outside.

i01447235

Before Operation

SMCS Code: 7000

Move all personnel from the machine and from the area.

Move all obstacles from the machine's path. Beware of hazards (wires, ditches, etc).

Be sure that all windows are clean. Secure the windows in the open position or in the shut position.

Adjust the mirrors for the best visibility close to the machine. Make sure that the horn, the backup alarm, and all other warning devices are working properly.

Fasten your seat belt securely.

A person that occupies the companion seat must wear the seat belt for the companion seat.

i03162317

Visibility Information

SMCS Code: 7000

Before you start the machine, perform a walk-around inspection in order to ensure that there are no hazards around the machine.

i03304240

While the machine is in operation, constantly survey the area around the machine in order to identify potential hazards as hazards become visible around the machine.

Your machine may be equipped with visual aids. Some examples of visual aids are Closed Circuit Television (CCTV) and mirrors. Before operating the machine, ensure that the visual aids are in proper working condition and that the visual aids are clean. Adjust the visual aids using the procedures that are located in this Operation and Maintenance Manual. If equipped, the Work Area Vision System shall be adjusted according to Operation and Maintenance Manual, SEBU8157, "Work Area Vision System".

It may not be possible to provide direct visibility on large machines to all areas around the machine. Appropriate job site organization is required in order to minimize hazards that are caused by restricted visibility. Job site organization is a collection of rules and procedures that coordinates machines and people that work together in the same area. Examples of job site organization include the following:

- Safety instructions
- Controlled patterns of machine movement and vehicle movement
- Workers that direct traffic to move when it is safe
- Restricted areas
- Operator training
- Warning symbols or warning signs on machines or on vehicles
- A system of communication
- Communication between workers and operators prior to approaching the machine

Modifications of the machine configuration by the user that result in a restriction of visibility shall be evaluated.

Restricted Visibility

SMCS Code: 7000

The size and the configuration of this machine may result in areas that can not be seen when the operator is seated. Illustration 21 provides an approximate visual indication of areas of significant restricted visibility. Illustration 21 indicates restricted visibility areas at ground level inside a radius of 12.00 m (39.37 ft) from the operator on a machine without the use of optional visual aids. This illustration does not provide any indication on areas of restricted visibility for distances outside a radius of 12.00 m (39.37 ft).

This machine may be equipped with optional visual aids that may provide visibility to some of the restricted visibility areas. For areas that are not covered by the optional visual aids, job site organization must be utilized to minimize hazards of this restricted visibility. For more information regarding job site organization refer to Operation and Maintenance Manual, "Visibility Information".

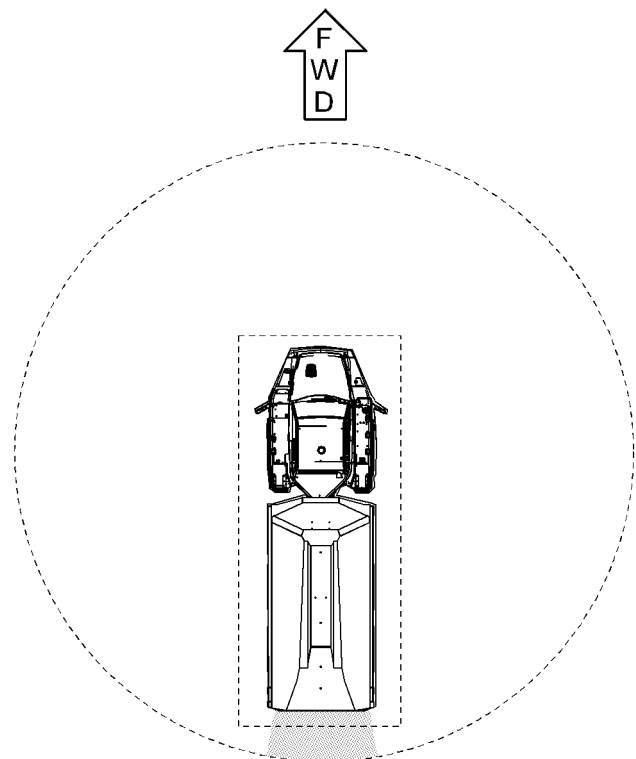

Illustration 21

g01687496

Top view of the machine

Note: The shaded areas indicate the approximate location of areas with significant restricted visibility.

i01439977

i02624835

Operation

SMCS Code: 7000

Only operate the machine while you are seated in the operator seat. The seat belt must be fastened while you operate the machine. A passenger must sit on the seat that is provided. If a passenger is carried the seat belt must be fastened.

Before you move the machine, you must make sure that no one will be endangered.

Check the proper operation of the steering controls and of the braking controls for the machine while the machine is moving slowly in an open area.

Do not allow riders on the machine.

Note any needed repairs during machine operation. Report any needed repairs.

Stay away from the edge of cliffs, overhangs and slide areas. Do not go close to the edge of a cliff, an excavation, or an overhang.

If the machine begins to sideslip downward on a grade, turn the machine downhill.

Avoid any conditions that can lead to tipping the machine. The machine can tip when you work on hills, on banks and on slopes. Also, the machine can tip when you cross ditches, ridges or other obstacles.

Avoid operating the machine across the slope. When possible, operate the machine up the slopes and down the slopes.

Maintain control of the machine. Do not load the machine beyond the machine capacity.

Stay in the cab while the machine is being loaded.

Travel with the dump body lowered to the frame.

Before operating a machine up a grade, select the gear that will give you full control under all conditions.

Know the maximum dimensions of your machine.

Inspect tires periodically during your shift. Allow tires to cool before going near the tires. Refer to Operation and Maintenance Manual, "Tire Information" for additional information.

Do not coast with the transmission in neutral.

Use a person to give signals when you enter a building. Use a person to give signals when you leave a building.

Engine Stopping

SMCS Code: 1000; 7000

Do not stop the engine immediately after the machine has been operated under load. This can cause overheating and accelerated wear of engine components.

After the machine is parked and the parking brake is engaged, allow the engine to run for two minutes before shutdown. This allows hot areas of the engine to cool gradually.

i01522321

Parking

SMCS Code: 7000

Park the machine on a level surface. If you must park on a grade, chock the machine's wheels.

Apply the service brakes in order to stop the machine. Move the transmission control to the NEUTRAL position. Move the accelerator control to the LOW IDLE position. Move the parking brake control to the ENGAGED position.

The dump body must be lowered to the frame.

The hoist control must be in the FLOAT position.

Run the engine at low idle for five minutes.

Stop the engine.

Turn the engine start switch to the OFF position and remove the engine start switch key.

Turn the battery disconnect switch to the OFF position. Remove the battery disconnect switch key if you do not operate the machine for an extended period of time. This will prevent drainage of the battery. A battery short circuit, any current draw from certain components, and vandalism can cause drainage of the battery.

i03745198

Slope Operation

SMCS Code: 7000

Machines that are operating safely in various applications depend on these criteria: the machine model, configuration, machine maintenance, operating speed of the machine, conditions of the terrain, fluid levels, and tire inflation pressures. The most important criteria are the skill and judgment of the operator.

A well trained operator that follows the instructions in the Operation and Maintenance Manual has the greatest impact on stability. Operator training provides a person with the following abilities: observation of working and environmental conditions, feel for the machine, identification of potential hazards, and operating the machine safely by making appropriate decisions.

When you work on side hills and when you work on slopes, consider the following important points:

Speed of travel – At higher speeds, forces of inertia tend to make the machine less stable.

Roughness of terrain or surface – The machine may be less stable with uneven terrain.

Direction of travel – Avoid operating the machine across the slope. When possible, operate the machine up the slopes and operate the machine down the slopes. Place the heaviest end of the machine uphill when you are working on an incline.

Mounted equipment – Balance of the machine may be impeded by the following components: equipment that is mounted on the machine, machine configuration, weights, and counterweights.

Nature of surface – Ground that has been newly filled with earth may collapse from the weight of the machine.

Surface material – Rocks and moisture of the surface material may drastically affect the machine's traction and machine's stability. Rocky surfaces may promote side slipping of the machine.

Slippage due to excessive loads – This may cause downhill tracks or downhill tires to dig into the ground, which will increase the angle of the machine.

Width of tracks or tires – Narrower tracks or narrower tires further increase the digging into the ground which causes the machine to be less stable.

Implements attached to the drawbar – This may decrease the weight on the uphill tracks. This may also decrease the weight on the uphill tires. The decreased weight will cause the machine to be less stable.

Height of the working load of the machine – When the working loads are in higher positions, the stability of the machine is reduced.

Operated equipment – Be aware of performance features of the equipment in operation and the effects on machine stability.

Operating techniques – Keep all attachments or pulled loads low to the ground for optimum stability.

Machine systems have limitations on slopes – Slopes can affect the proper function and operation of the various machine systems. These machine systems are needed for machine control.

Note: Safe operation on steep slopes may require special machine maintenance. Excellent skill of the operator and proper equipment for specific applications are also required. Consult the Operation and Maintenance Manual sections for the proper fluid level requirements and intended machine use.

i01329161

Equipment Lowering with Engine Stopped

SMCS Code: 7000

Before lowering any equipment with the engine stopped, clear the area around the equipment of all personnel. The procedure to use will vary with the type of equipment to be lowered. Keep in mind most systems use a high pressure fluid or air to raise or lower equipment. The procedure will cause high pressure air, hydraulic, or some other media to be released in order to lower the equipment. Wear appropriate personal protective equipment and follow the established procedure in the Operation and Maintenance Manual, "Equipment Lowering with Engine Stopped" in the Operation Section of the manual.

i03745287

Sound Information and Vibration Information

SMCS Code: 7000

Sound Level Information for Machines in European Union Countries and in Countries that Adopt the “EU Directives”

The static operator sound pressure level is 76 dB(A) when “ISO 6394:1998” is used to measure the value for an enclosed cab. The cab was properly installed and maintained. The test was conducted with the cab doors and the cab windows closed.

Hearing protection may be needed when the machine is operated with an open operator station for extended periods or in a noisy environment. Hearing protection may be needed when the machine is operated with a cab that is not properly maintained or when the doors and windows are open for extended periods or in a noisy environment.

“The European Union Physical Agents (Vibration) Directive 2002/44/EC”

Vibration Data for Articulated Trucks

Information Concerning Hand/Arm Vibration Level

When the machine is operated according to the intended use, the hand/arm vibration of this machine is below 2.5 meter per second squared.

Information Concerning Whole Body Vibration Level

This section provides vibration data and a method for estimating the vibration level for articulated trucks.

Note: Vibration levels are influenced by many different parameters. Many items are listed below.

- Operator training, behavior, mode, and stress
- Job site organization, preparation, environment, weather, and material
- Machine type, quality of the seat, quality of the suspension system, attachments, and condition of the equipment

It is not possible to get precise vibration levels for this machine. The expected vibration levels can be estimated with the information in Table 1 in order to calculate the daily vibration exposure. A simple evaluation of the machine application can be used.

Estimate the vibration levels for the three vibration directions. For typical operating conditions, use the average vibration levels as the estimated level. With an experienced operator and smooth terrain, subtract the Scenario Factors from the average vibration level in order to obtain the estimated vibration level. For aggressive operations and severe terrain, add the Scenario Factors to the average vibration level in order to obtain the estimated vibration level.

Note: All vibration levels are in meter per second squared.

Table 1

"ISO Reference Table A - Equivalent vibration levels of whole body vibration emission for earthmoving equipment."							
Machine Type	Typical Operating Activity	Vibration Levels			Scenario Factors		
		X axis	Y axis	Z axis	X axis	Y axis	Z axis
Articulated Trucks	loading process	0,29	0,41	0,24	0,17	0,23	0,16
	travel loaded	0,64	0,89	0,67	0,21	0,29	0,21
	travel unloaded	0,82	1,02	0,81	0,26	0,26	0,28
	unloading	0,49	0,42	0,30	0,25	0,33	0,18

Note: Refer to "ISO/TR 25398 Mechanical Vibration - Guideline for the assessment of exposure to whole body vibration of ride on operated earthmoving machines" for more information about vibration. This publication uses data that is measured by international institutes, organizations and manufacturers. This document provides information about the whole body exposure of operators of earthmoving equipment. Refer to Operation and Maintenance Manual, SEBU8257, "The European Union Physical Agents (Vibration) Directive 2002/44/EC" for more information about machine vibration levels.

The Caterpillar suspension seat meets the criteria of "ISO 7096". This represents vertical vibration level under severe operating conditions. This seat is tested with the input "spectral class EM1". The seat has a transmissibility factor of "SEAT<1.1".

The whole body vibration level of the machine varies. There is a range of values. The low value is 0.5 meter per second squared. The machine meets the short term level for the design of the seat in "ISO 7096". The value is 1.02 meter per second squared for this machine.

Guidelines for Reducing Vibration Levels on Earthmoving Equipment

Properly adjust machines. Properly maintain machines. Operate machines smoothly. Maintain the conditions of the terrain. The following guidelines can help reduce the whole body vibration level:

1. Use the right type and size of machine, equipment, and attachments.
2. Maintain machines according to the manufacturer's recommendations.
 - a. Tire pressures
 - b. Brake and steering systems
 - c. Controls, hydraulic system and linkages
3. Keep the terrain in good condition.
 - a. Remove any large rocks or obstacles.
 - b. Fill any ditches and holes.
 - c. Provide machines and schedule time in order to maintain the conditions of the terrain.
4. Use a seat that meets "ISO 7096". Keep the seat maintained and adjusted.
 - a. Adjust the seat and suspension for the weight and the size of the operator.
 - b. Inspect and maintain the seat suspension and adjustment mechanisms.
5. Perform the following operations smoothly.
 - a. Steer
 - b. Brake
 - c. Accelerate.
 - d. Shift the gears.
6. Move the attachments smoothly.
7. Adjust the machine speed and the route in order to minimize the vibration level.
 - a. Drive around obstacles and rough terrain.
 - b. Slow down when it is necessary to go over rough terrain.
8. Minimize vibrations for a long work cycle or a long travel distance.
 - a. Use machines that are equipped with suspension systems.
 - b. Use the ride control system on articulated trucks.
 - c. If no ride control system is available, reduce speed in order to prevent bounce.
 - d. Haul the machines between workplaces.

9. Less operator comfort may be caused by other risk factors. The following guidelines can be effective in order to provide better operator comfort:

i03634321

- a. Adjust the seat and adjust the controls in order to achieve good posture.
- b. Adjust the mirrors in order to minimize twisted posture.
- c. Provide breaks in order to reduce long periods of sitting.
- d. Avoid jumping from the cab.
- e. Minimize repeated handling of loads and lifting of loads.
- f. Minimize any shocks and impacts during sports and leisure activities.

Sources

The vibration information and calculation procedure is based on "ISO/TR 25398 Mechanical Vibration - Guideline for the assessment of exposure to whole body vibration of ride on operated earthmoving machines". Harmonized data is measured by international institutes, organizations and manufacturers.

This literature provides information about assessing the whole body vibration exposure of operators of earthmoving equipment. The method is based on measured vibration emission under real working conditions for all machines.

You should check the original directive. This document summarizes part of the content of the applicable law. This document is not meant to substitute the original sources. Other parts of these documents are based on information from the United Kingdom Health and Safety Executive.

Refer to Operation and Maintenance Manual, SEBU8257, "The European Union Physical Agents (Vibration) Directive 2002/44/EC" for more information about vibration.

Consult your local Caterpillar dealer for more information about machine features that minimize vibration levels. Consult your local Caterpillar dealer about safe machine operation.

Use the following web site in order to find your local dealer:

Caterpillar, Inc.
www.cat.com

Operator Station

SMCS Code: 7000

Any modifications to the inside of the operator station should not project into the operator space or into the space for the companion seat (if equipped). The addition of a radio, fire extinguisher, and other equipment must be installed so that the defined operator space and the space for the companion seat (if equipped) is maintained. Any item that is brought into the cab should not project into the defined operator space or the space for the companion seat (if equipped). A lunch box or other loose items must be secured. Objects must not pose an impact hazard in rough terrain or in the event of a rollover.

i03656846

Guards (Operator Protection)

SMCS Code: 7000; 7150; 7325

There are different types of guards that are used to protect the operator. The machine and the machine application determines the type of guard that should be used.

A daily inspection of the guards is required in order to check for structures that are bent, cracked or loose. Never operate a machine with a damaged structure.

The operator becomes exposed to a hazardous situation if the machine is used improperly or if poor operating techniques are used. This situation can occur even though a machine is equipped with an appropriate protective guard. Follow the established operating procedures that are recommended for your machine.

Rollover Protective Structure (ROPS), Falling Object Protective Structure (FOPS) or Tip Over Protection Structure (TOPS)

The ROPS/FOPS Structure (if equipped) on your machine is specifically designed, tested and certified for that machine. Any alteration or any modification to the ROPS/FOPS Structure could weaken the structure. This places the operator into an unprotected environment. Modifications or attachments that cause the machine to exceed the weight that is stamped on the certification plate also place the operator into an unprotected environment. Excessive weight may inhibit the brake performance, the steering performance and the ROPS. The protection that is offered by the ROPS/FOPS Structure will be impaired if the ROPS/FOPS Structure has structural damage. Damage to the structure can be caused by an overturn, a falling object, a collision, etc.

Do not mount items (fire extinguishers, first aid kits, work lights, etc) by welding brackets to the ROPS/FOPS Structure or by drilling holes in the ROPS/FOPS Structure. Welding brackets or drilling holes in the ROPS/FOPS Structures can weaken the structures. Consult your Caterpillar dealer for mounting guidelines.

The Tip Over Protection Structure (TOPS) is another type of guard that is used on mini hydraulic excavators. This structure protects the operator in the event of a tipover. The same guidelines for the inspection, the maintenance and the modification of the ROPS/FOPS Structure are required for the Tip Over Protection Structure.

Other Guards (If Equipped)

Protection from flying objects and/or falling objects is required for special applications. Logging applications and demolition applications are two examples that require special protection.

A front guard needs to be installed when a work tool that creates flying objects is used. Mesh front guards that are approved by Caterpillar or polycarbonate front guards that are approved by Caterpillar are available for machines with a cab or an open canopy. On machines that are equipped with cabs, the windows should also be closed. Safety glasses are recommended when flying hazards exist for machines with cabs and machines with open canopies.

If the work material extends above the cab, top guards and front guards should be used. Typical examples of this type of application are listed below:

- Demolition applications

- Rock quarries
- Forestry products

Additional guards may be required for specific applications or work tools. The Operation and Maintenance Manual for your machine or your work tool will provide specific requirements for the guards. Consult your Caterpillar dealer for additional information.

i03307609

Body Support

SMCS Code: 0635; 7258-S4

Before you perform any testing or adjusting, park the machine on a level surface. Move the parking brake control to the ENGAGED position and shut off the engine. Lower the body and move the hoist control to the FLOAT position.

Install the steering frame locks before entering the area around the oscillating hitch.

If the body must be raised, perform the following procedure in order to install the body support.

Note: The body must be empty before the body support is installed.

1. Raise the body enough to lift the body support and then move the hoist control to the HOLD position.



Illustration 22

g00805992

Typical Example

2. Lift the body support.
3. Move the hoist control to the FLOAT position. This will allow the body to lower slowly until the weight of the body is supported by the body support.

Note: The body must be raised before the body support can be lowered.

4. Move the hoist control to the HOLD position and shut off the engine.

Allow only one operator on the machine. Keep all other personnel away from the machine. Also, all personnel should be visible to the operator.