

ML-96HS

(Natural Gas)

Installation Manual

WARNING: For your safety the information in this manual must be followed to minimize the risk of fire or explosion or to prevent property damage, personal injury or death.

— Do not store or use gasoline or other flammable vapor and liquids in the vicinity of this or any other appliance.

— **WHAT DO YOU DO IF YOU SMELL GAS**

- * Do not try to light any appliance.
- * Do not touch any electrical switch; do not use any phone in your building.
- * Clear the room, building or area of all occupants.
- * Immediately call your gas supplier from a neighbor's phone. Follow the gas supplier's instructions.
- * If you cannot reach your gas supplier, call the fire department.

— Installation and service must be performed by a qualified installer, service agency or the gas supplier.

AVERTISSEMENT: Assurez-vous de bien suivre les instructions données dans cette notice pour réduire au minimum le risque d'incendie ou d'explosion ou pour éviter tout dommage matériel, toute blessure ou la mort.

— Ne pas entreposer ni utiliser d'essence ni d'autres vapeurs ou liquides inflammables dans le voisinage de cet appareil ou de tout autre appareil.

— **QUE FAIRE SI VOUS SENTEZ UNE ODEUR DE GAZ:**

- * Ne pas tenter d'allumer d'appareil.
- * Ne touchez à aucun interrupteur. Ne pas vous servir des téléphones se trouvant dans le bâtiment où vous vous trouvez..
- * Évacuez la pièce, le bâtiment ou la zone.
- * Appelez immédiatement votre fournisseur de gaz depuis un voisin. Suivez les instructions du fournisseur.
- * Si vous ne pouvez rejoindre le fournisseur de gaz, appelez le service des incendies.

— L'installation et l'entretien doivent être assurés par un installateur ou un service d'entretien qualifié ou par le fournisseur de gaz.



For replacement parts, contact the reseller from which the dryer was purchased or

American Dryer Corporation

88 Currant Road

Fall River MA 02720-4781

Telephone: (508) 678-9000 / Fax: (508) 678-9447

E-mail: techsupport@amdry.com

Retain This Manual In A Safe Place For Future Reference

American Dryer Corporation products embody advanced concepts in engineering, design, and safety. If this product is properly maintained, it will provide many years of safe, efficient, and trouble-free operation.

ONLY qualified technicians should service this equipment.

OBSERVE ALL SAFETY PRECAUTIONS displayed on the equipment or specified in the installation manual included with the dryer.

The following “**FOR YOUR SAFETY**” caution **must be** posted near the dryer in a prominent location.

FOR YOUR SAFETY

Do not store or use gasoline or other flammable vapors or liquids in the vicinity of this or any other appliance.

POUR VOTRE SÉCURITÉ

Ne pas entreposer ni utiliser d'essence ni d'autres vapeurs ou liquides inflammables dans le voisinage de cet appareil ou de tout autre appareil.

We have tried to make this manual as complete as possible and hope you will find it useful. **ADC** reserves the right to make changes from time to time, without notice or obligation, in prices, specifications, colors, and material, and to change or discontinue models.

Important

For your convenience, log the following information:

DATE OF PURCHASE _____ MODEL NO. **ML-96 HS** _____
RESELLER'S NAME _____
Serial Number(s) _____

Replacement parts can be obtained from your reseller or the **ADC** factory. When ordering replacement parts from the factory, you can FAX your order to **ADC** at (508) 678-9447 or telephone your orders directly to the **ADC** Parts Department at (508) 678-9000. Please specify the dryer **model number** and **serial number** in addition to the **description** and **part number**, so that your order is processed accurately and promptly.

The illustrations on the following pages may not depict your particular dryer exactly. The illustrations are a composite of the various dryer models. Be sure to check the descriptions of the parts thoroughly before ordering.

“IMPORTANT NOTE TO PURCHASER”

Information must be obtained from your local gas supplier on the instructions to be followed if the user smells gas. These instructions must be posted in a prominent location near the dryer.

IMPORTANT

YOU MUST DISCONNECT and LOCKOUT THE ELECTRIC SUPPLY and THE GAS SUPPLY or THE STEAM SUPPLY BEFORE ANY COVERS or GUARDS ARE REMOVED FROM THE MACHINE TO ALLOW ACCESS FOR CLEANING, ADJUSTING, INSTALLATION, or TESTING OF ANY EQUIPMENT per OSHA (Occupational Safety and Health Administration) STANDARDS.

“Caution: Label all wires prior to disconnection when servicing controls. Wiring errors can cause improper operation.”

«Attention: Lors des opérations d'entretien des commandes étiqueter tous fils avant de les déconnecter. Toute erreur de câblage peut être une source de danger et de panne.»

CAUTION

DRYER(S) SHOULD NEVER BE LEFT UNATTENDED WHILE IN OPERATION.

WARNING

**CHILDREN SHOULD NOT BE ALLOWED TO PLAY ON OR NEAR THE DRYERS.
CHILDREN SHOULD BE SUPERVISED IF NEAR DRYERS IN OPERATION.**

FOR YOUR SAFETY

**DO NOT DRY MOP HEADS IN THE DRYER.
DO NOT USE DRYER IN THE PRESENCE OF DRY CLEANING FUMES.**

WARNING

UNDER NO CIRCUMSTANCES should the door switch or the heat circuit devices ever be disabled.

WARNING

The dryer must never be operated with any of the back guards, outer tops, or service panels removed. **PERSONAL INJURY or FIRE COULD RESULT.**

WARNING

DRYER MUST NEVER BE OPERATED WITHOUT THE LINT FILTER/SCREEN IN PLACE, EVEN IF AN EXTERNAL LINT COLLECTION SYSTEM IS USED.

IMPORTANT

PLEASE OBSERVE ALL SAFETY PRECAUTIONS displayed on the equipment and/or specified in the installation and operator's manual included with the dryer.

Dryers **must not** be installed or stored in an area where it will be exposed to water or weather.

The wiring diagram for the dryer is located in the front electrical control box area.

Table of Contents

SECTION I

IMPORTANT INFORMATION	2
A. RECEIVING and HANDLING.....	2
B. SAFETY PRECAUTIONS	3

SECTION II

SPECIFICATIONS/COMPONENT IDENTIFICATION	5
A. SPECIFICATIONS	5
B. COMPONENT IDENTIFICATION	7

SECTION III

INSTALLATION PROCEDURES	9
A. LOCATION REQUIREMENTS	9
B. UNPACKING/SETTING UP	10
C. DRYER ENCLOSURE REQUIREMENTS	12
D. FRESH AIR SUPPLY	13
E. EXHAUST REQUIREMENTS	14
F. ELECTRICAL INFORMATION	18
G. GAS INFORMATION	21
H. PREPARATION FOR OPERATION/START-UP	24
I. PREOPERATIONAL TESTS	25
J. OPERATING INSTRUCTIONS	26
K. SHUT DOWN INSTRUCTIONS	26

SECTION IV

SERVICE/PARTS INFORMATION	27
A. SERVICE.....	27
B. PARTS	27

SECTION V

WARRANTY INFORMATION	28
A. RETURNING WARRANTY CARDS	28
B. PARTS	28
C. RETURNING WARRANTY PARTS	

SECTION VI

ROUTINE MAINTENANCE.....	30
A. CLEANING	30
B. ADJUSTMENTS	31
C. LUBRICATIONS	31

SECTION VII

PROCEDURE FOR FUNCTIONAL CHECK OF REPLACEMENT COMPONENTS	32
---	-----------

SECTION I

IMPORTANT INFORMATION

A. RECEIVING and HANDLING

The dryer is shipped in a protective stretch wrap cover with protective cardboard corners and top cover (or optional box) as a means of preventing damage in transit. Upon delivery, the dryer and packaging, and wooden skid **should be** visually inspected for shipping damage. If any damage whatsoever is noticed, inspect further before delivering carrier leaves.

Dryers damaged in shipment.

1. **ALL** dryers **should be** inspected upon receipt and before they are signed for.
2. If there is suspected damage or actual damage, the trucker's receipt **should be** so noted.
3. If the dryer is damaged beyond repair, it **should be** refused. Those dryers which were not damaged in a damaged shipment **should be** accepted, but the number received and the number refused **must be** noted on the receipt.
4. If you determine that the dryer was damaged after the trucker has left your location, you should call the delivering carrier's freight terminal immediately and file a claim. The freight company considers this concealed damage. This type of freight claim is very difficult to get paid and becomes extremely difficult when more than a day or two passes after the freight was delivered. It is your responsibility to file freight claims. Dryer or parts damaged in transit **cannot** be claimed under warranty.
5. Freight claims are the responsibility of the consignee, and **ALL** claims **must be** filed at the receiving end. **ADC** assumes no responsibility for freight claims or damages.
6. If you need assistance in handling the situation, please contact the **ADC** Traffic Manager at (508) 678-9000.

IMPORTANT: The tumbler section of the dryer **must be** transported and handled in an upright position at all times.

B. SAFETY PRECAUTIONS

WARNING: For your safety, the information in this manual *must be* followed to minimize the risk of fire or explosion or to prevent property damage, personal injury, or loss of life.

WARNING: The dryer must never be operated with any of the back guards, outer tops, or service panels removed. PERSONAL INJURY or FIRE COULD RESULT.

1. **DO NOT** store or use gasoline or other flammable vapors and liquids in the vicinity of this or any other appliance.
2. Purchaser or user should consult the local gas supplier for proper instructions to be followed in the event the user smells gas. The instructions **should be** posted in a prominent location.
3. WHAT TO DO IF YOU SMELL GAS
 - a. **DO NOT** try to light any appliance.
 - b. **DO NOT** touch any electrical switch.
 - c. **DO NOT** use any phone in your building.
 - d. Clear the room, building, or area of ALL occupants.
 - e. Immediately call your gas supplier from a neighbor's phone. Follow the gas supplier's instructions.
 - f. If you **cannot** reach your gas supplier, call the fire department.
4. Installation and service **must be** performed by a qualified installer, service agency, or gas supplier.
5. Dryers **must be** exhausted to the outdoors.
6. Although ADC produces a very versatile machine, there are some articles that, due to fabric composition or cleaning method, **should not** be dried in it.

WARNING: Dry only water-washed fabrics. **DO NOT** dry articles spotted or washed in dry cleaning solvents, a combustible detergent, or "all purpose" cleaner.
EXPLOSION COULD RESULT.

WARNING: DO NOT dry rags or articles coated or contaminated with gasoline, kerosene, oil, paint, wax. **EXPLOSION COULD RESULT.**

WARNING: DO NOT dry mop heads. Contamination by wax or flammable solvents will create a fire hazard.

WARNING: DO NOT use heat for drying articles that contain plastic, foam, sponge rubber, or similarly textured rubber materials. Drying in a heated basket (tumbler) may damage plastics or rubber and also may be a fire hazard.

7. A program **should be** established for the inspection and cleaning of lint in the heating unit area, exhaust duct work, and inside the dryer. The frequency of inspection and cleaning can best be determined from experience at each location.

WARNING: The collection of lint in the burner area and exhaust duct work can create a potential fire hazard.

8. For personal safety, the dryer **must be** electrically grounded in accordance with local codes and/or the National Electric Code ANSI/NFPA NO. 70-LATEST EDITION or CAN/CGA-B149.2-M91 (L.P. Gas) or LATEST EDITION (for GENERAL INSTALLATION and GAS PLUMBING) or CANADIAN ELECTRICAL CODES PARTS 1 and 2 CSA C22.1-1990 or LATEST EDITION (for ELECTRICAL CONNECTIONS).

NOTE: Failure to do so will VOID THE WARRANTY.

9. **UNDER NO CIRCUMSTANCES** should the dryer drawer switches, lint door switch, heat safety circuit ever be disabled.

WARNING: PERSONAL INJURY or FIRE COULD RESULT.

10. This dryer is not to be used in the presence of dry cleaning solvents or fumes.
11. Remove articles from the dryer as soon as the drying cycle has been completed.

WARNING: Articles left in the dryer after the drying and cooling cycles have been completed can create a fire hazard.

12. **READ and FOLLOW ALL CAUTION and DIRECTION LABELS ATTACHED TO THE DRYER.**

WARNING: YOU MUST DISCONNECT and LOCKOUT THE ELECTRIC SUPPLY and THE GAS SUPPLY BEFORE ANY COVERS or GUARDS ARE REMOVED FROM THE MACHINE TO ALLOW ACCESS FOR CLEANING, ADJUSTING, INSTALLATION, or TESTING OF ANY EQUIPMENT per OSHA (Occupational Safety and Health Administration) STANDARDS.

SECTION II

SPECIFICATIONS/COMPONENT IDENTIFICATION

A. SPECIFICATIONS

MAXIMUM CAPACITY (DRY WEIGHT)	95 lbs.	43.1 kg	
BASKET (TUMBLER) DIAMETER	42"	106.7 cm	
BASKET (TUMBLER) DEPTH	29-1/4"	74.3 cm	
BASKET (TUMBLER) MOTOR	1/2 HP	.373 kw	
BLOWER MOTOR	3 HP	2.238 kw	
DOOR OPENING (DIAMETER)	30-3/4"	78.1 cm	
BASKET (TUMBLER) VOLUME	23.5 cu. ft.	.67cu.m.	
DRYERS PER 20'/40" CONTAINER	10/20		
DRYERS PER 45'/48' TRUCK	24/24		
Gas	VOLTAGE AVAILABLE	208-460v / 3 ϕ / 3, 4w / 50/60 Hz	
	APPROX. WEIGHT (UNCRATED)	1,000 lbs.	453.6 kg
	APPROX. WEIGHT (CRATED)	878 lbs.	544.3 kg
	HEAT INPUT	350,000 btu/hr	88,199 kcal/hr
	AIRFLOW	2,700 cfm	76.5 cmm
	INLET PIPE CONNECTION*	1"	---
	COMPRESSED AIR VOLUME	.75 cfh	.02 cmh
	COMPRESSED AIR CONNECTION	1/8" F.P.T.	---

Shaded areas are stated in metric equivalents

* Size of piping varies with installation conditions.

IMPORTANT: Dryer must be supplied with clean, dry and regulated air pressure at 80 psi \pm 10 psi (5.5 bar \pm 69 bar).

NOTE: ADC reserves the right to make changes in specifications at any time, without notice or obligation.

MLG-96 (Natural Gas)

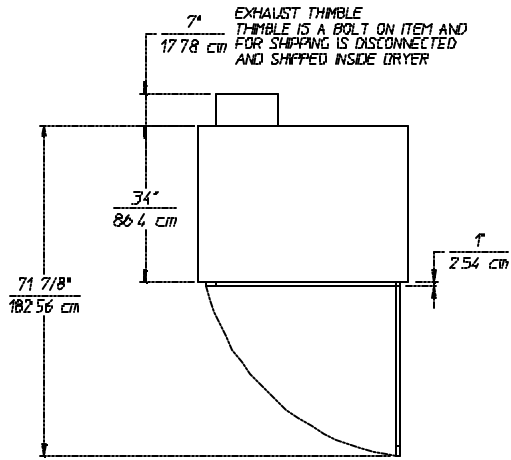

PLAN VIEW

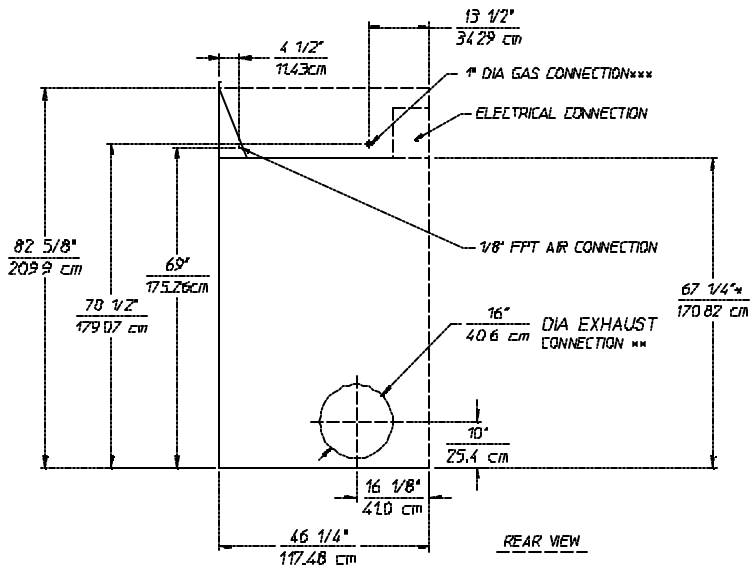

REAR VIEW

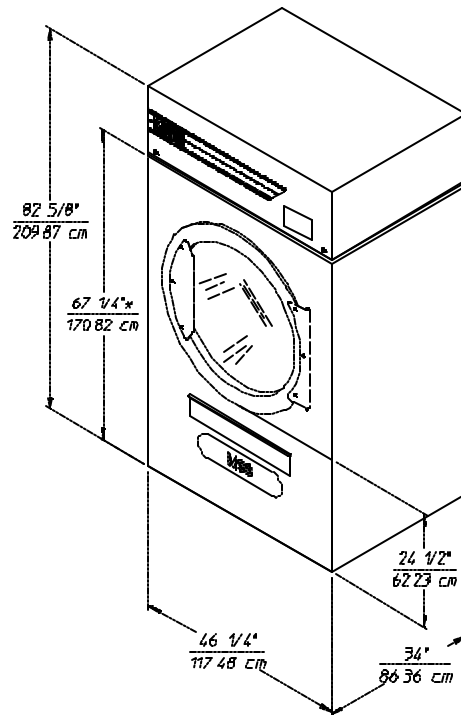

SPEC264

* TOP SECTION CAN BE REMOVED FOR EASY INSTALLATION
 ** DUCT WORK SIZE VARIES WITH INSTALLATION CONDITIONS
 *** SIZE OF PIPING TO DRYER VARIES WITH INSTALLATION CONDITIONS CONTACT FACTORY FOR ASSISTANCE

NOTE: ADC reserves the right to make changes in specifications at any time, without notice or obligation.

B. COMPONENT IDENTIFICATION

1. Dryer Front View

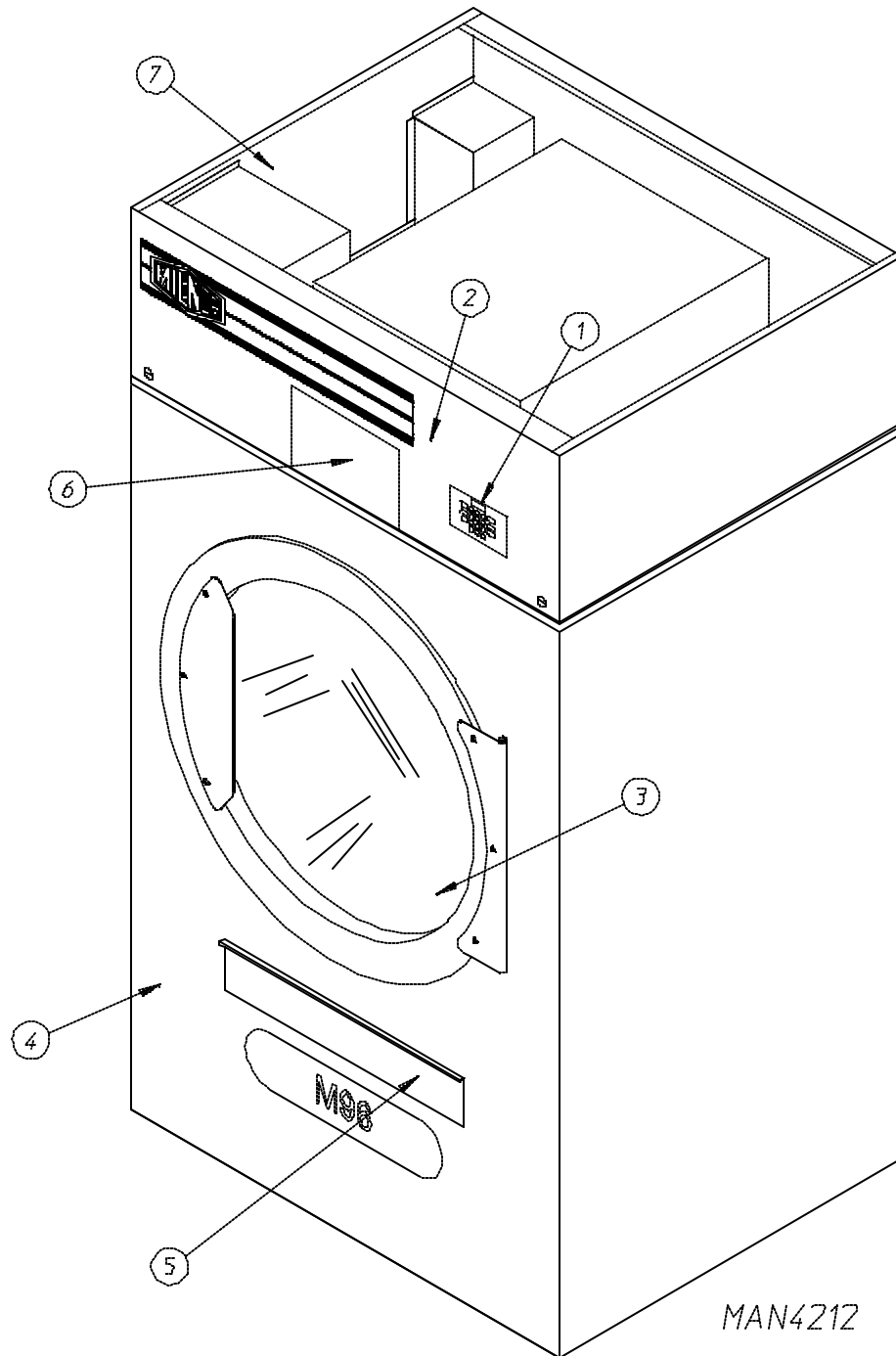

<u>Illus. No.</u>	<u>Description</u>
-------------------	--------------------

- | | |
|---|---|
| 1 | Microprocessor Control/Keyboard Panel Assembly (Controls) |
| 2 | Control (Top Access) Door Assembly |
| 3 | Main Door Assembly |
| 4 | Lint Panel Assembly |
| 5 | Lint Door |
| 6 | Wire Diagram (Located Behind Control Door) |
| 7 | Top Console (Module) Assembly |

2. Dryer Rear View

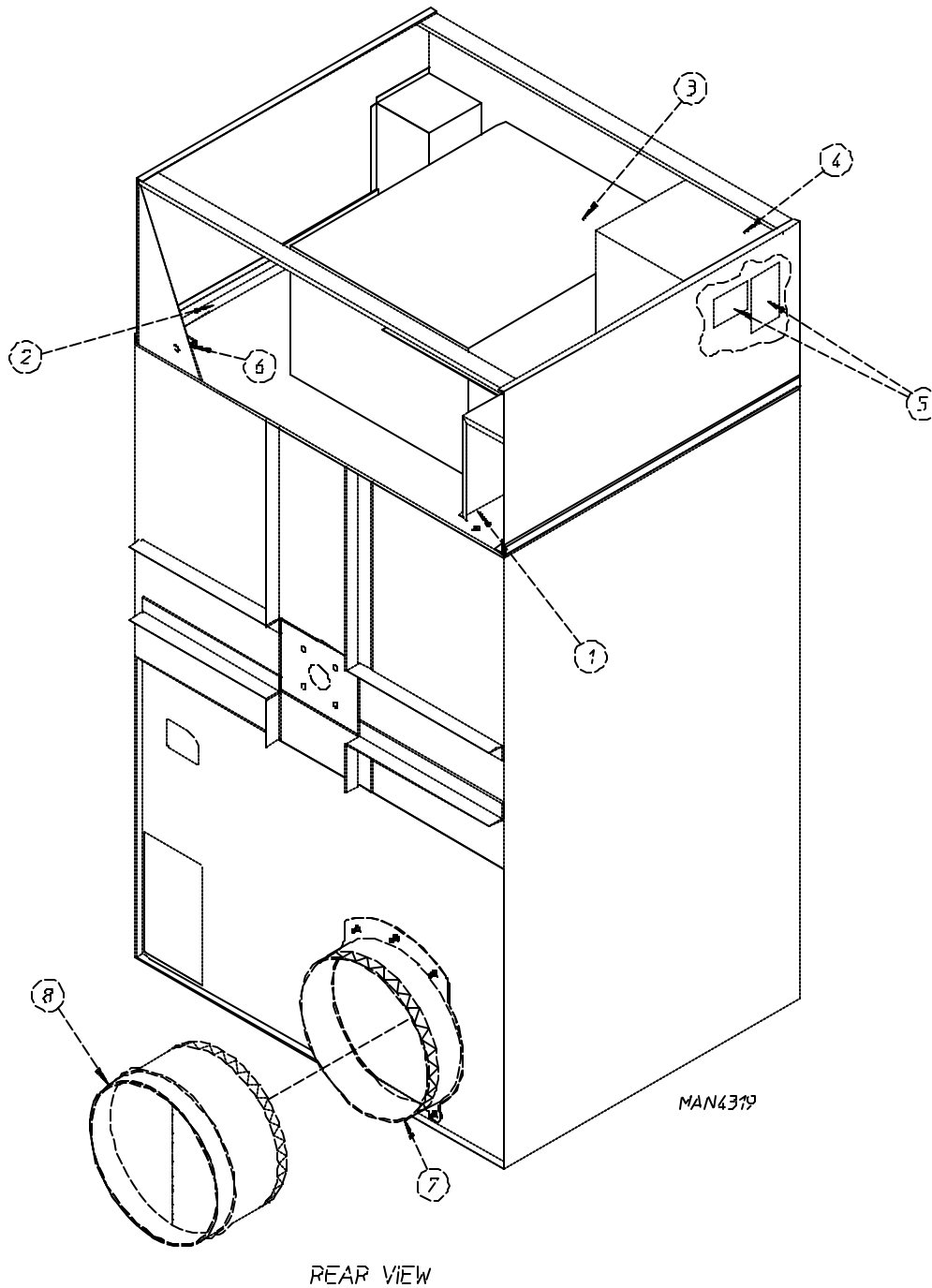

Illus. No. Description

- 1 Electrical Service Connections
- 2 Top Console
- 3 Heating Unit
- 4 Relay/Wiring Box
- 5 Data Label and Installation Label
- 6 Air Connection
- 7 Exhaust Transition Piece
- 8 Exhaust Damper Assembly (**must be** installed at time of dryer installation). This damper is shipped inside the dryer tumbler (basket)

SECTION III

INSTALLATION PROCEDURES

Installation **should be** performed by competent technicians in accordance with local and state codes. In the absence of these codes, the installation **must conform** to applicable American National Standards: National Fuel Gas Code ANSI.Z223.1-LATEST EDITION or National Electric Code ANSI/NFPA NO. 70-LATEST EDITION, or in CANADA, the installation **must conform** to applicable CANADIAN STANDARDS: CAN/CGA-B149.1-M91 (Natural Gas).

A. LOCATION REQUIREMENTS

Before installing the dryer, be sure the location conforms to local codes and ordinances. In the absence of such codes or ordinances the location **must conform** with the National Fuel Gas Code ANSI.Z223.1-LATEST EDITION, or in CANADA, the Canadian Installation Codes: CAN/CGA-B149.1-M91 (Natural Gas) or CAN/CGA-B149.2-M91 (L.P. Gas) or LATEST EDITION.

1. The dryer **must be** installed on a sound level floor capable of supporting its weight. It is recommended that carpeting be removed from the floor area that the dryer is to rest on.
2. The dryer **must not be** installed or stored in an area where it will be exposed to water and/or weather.
3. The dryer is for use in noncombustible locations.
4. Provisions for adequate air supply **must be** provided as noted in this manual (refer to **Fresh Air Supply in Section D**).
5. Clearance provisions **must be** made from combustible construction as noted in this manual (refer to **Dryer Enclosure Requirements in Section C**).
6. Provisions **must be** made for adequate clearances for servicing and for operation as noted in this manual (refer to **Dryer Enclosure Requirements in Section C**).
7. Dryer **must be** exhausted to the outdoors (refer to **Exhaust Requirements in Section E**).
8. Dryer **must be** located in an area where correct exhaust venting can be achieved as noted in the manual (refer to **Exhaust Requirements in Section E**).

IMPORTANT: Dryer *should be* located where a minimum amount of exhaust duct *will be* necessary.

B. UNPACKING and SETTING UP

Remove protective shipping material (i.e., plastic wrap, and optional shipping box) from dryer.

IMPORTANT: Dryer *must be* transported and handled in an upright position at all times.

The dryer can be moved to its final location while still attached to the skid or with the skid removed. To unskid the dryer, locate and remove the four (4) bolts securing the base of the dryer to the wooden skid. Two (2) are at the rear base (remove the back panel for access), and two (2) are located in the bottom of the lint chamber. To remove the two (2) bolts located in the lint chamber area, remove the lint door.

To increase bearing life and improve efficiency, the dryer **should be** tilted slightly to the rear.

For shipping purposes the 16" butterfly damper assembly is shipped in the basket of the dryer. For assembly of this damper assembly refer to **page 8**.

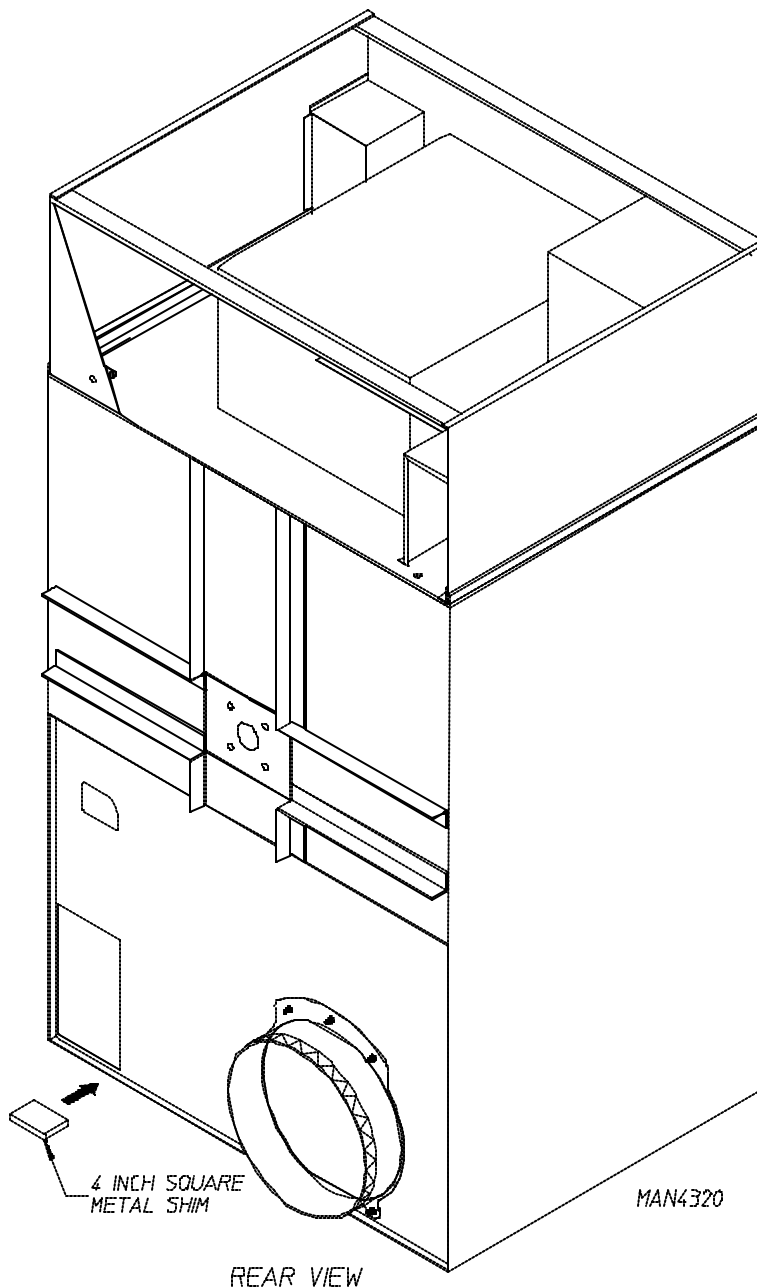

1. Leveling Dryer

To level dryer, place 4-inch square metal shims (refer to illustration on the previous page [[page 10](#)]) or other suitable material under the base pads. It is suggested that the dryer be tilted slightly to the rear. If more headroom is needed when moving dryer into position, the top console (module) may be removed.

- a. To remove top console (module).

NOTE: *DO NOT* have power connected when separating the top console.

- 1) Disconnect the ground wire at the rear of dryer (A).
- 2) Remove the six (6) sets of nuts and washers (B) holding the console (module) to base. (Located within control boxes)
- 3) Open control door and control panel then disconnect the following:
 - a) There are three (3) harnesses that need to be disconnected in the right hand electrical box;
 - (1) Disconnect the 4-pin connector containing both the main door and the lint door switch harness.
 - (2) Disconnect the 4-pin connector containing the temperature sensor and the rotational sensor on the microprocessor (computer).
 - (3) Disconnect the 2-pin connector that contains the tumbler (basket) hi-limit connector on the microprocessor (computer).
 - (4) Disconnect the air connection at the compression fitting.
 - b) On the left side box, disconnect the drive and blower motor wires, along with the 2-pin connector on the blower motor harness.
- 4) Lift the console (module) off of the dryer base (C).

IMPORTANT: The dryer *must be* transported and handled in an upright position at all times.

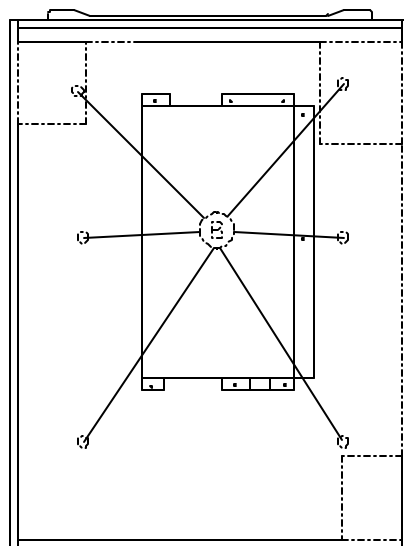

TOP VIEW

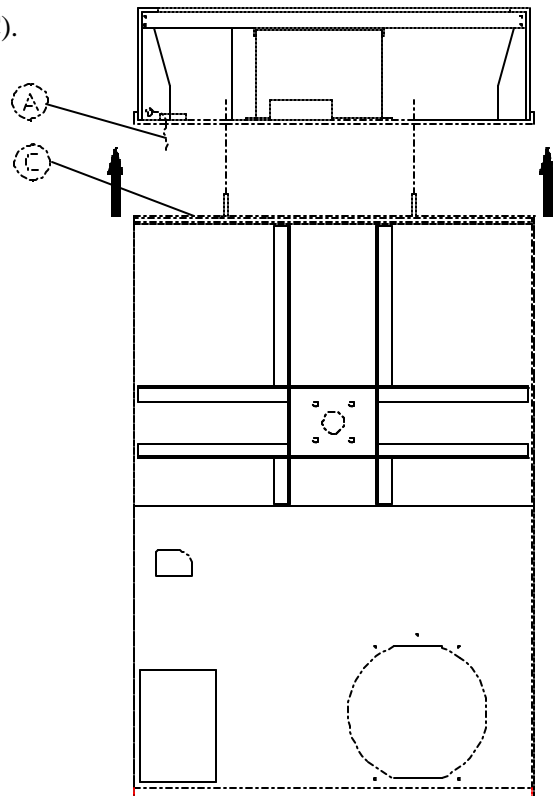

MAN425

REAR VIEW

C. DRYER ENCLOSURE REQUIREMENTS

Even though a 30-inch clearance is acceptable, it is recommended that the rear of the dryer be positioned approximately three (3) feet (36-inches) from nearest obstruction (i.e. wall) for ease of installation, maintenance and service. Bulkheads and partitions **should be** made from noncombustible materials. The clearance between the bulkhead header and the dryer **must be** a minimum of 4-inches and must not extend more than 4-inches to the rear of the dryer front. The bulkhead facing must not be closed in all the way to the top of the dryer. A 2-inch clearance is required.

NOTE: Bulkhead facing *should not be* installed until after dryer is in place. Ceiling area *must be* located a minimum of 12-inches above the top of the dryer.

NOTE: When fire sprinkler systems are located above the dryers, a minimum of 18-inches above the dryer console (module) is suggested. Dryers may be positioned side wall to side wall however, 1 or 2 inches is suggested between dryers (or wall) for ease of installation and maintenance. Allowances *must be* made for the opening and closing of the control and lint doors.

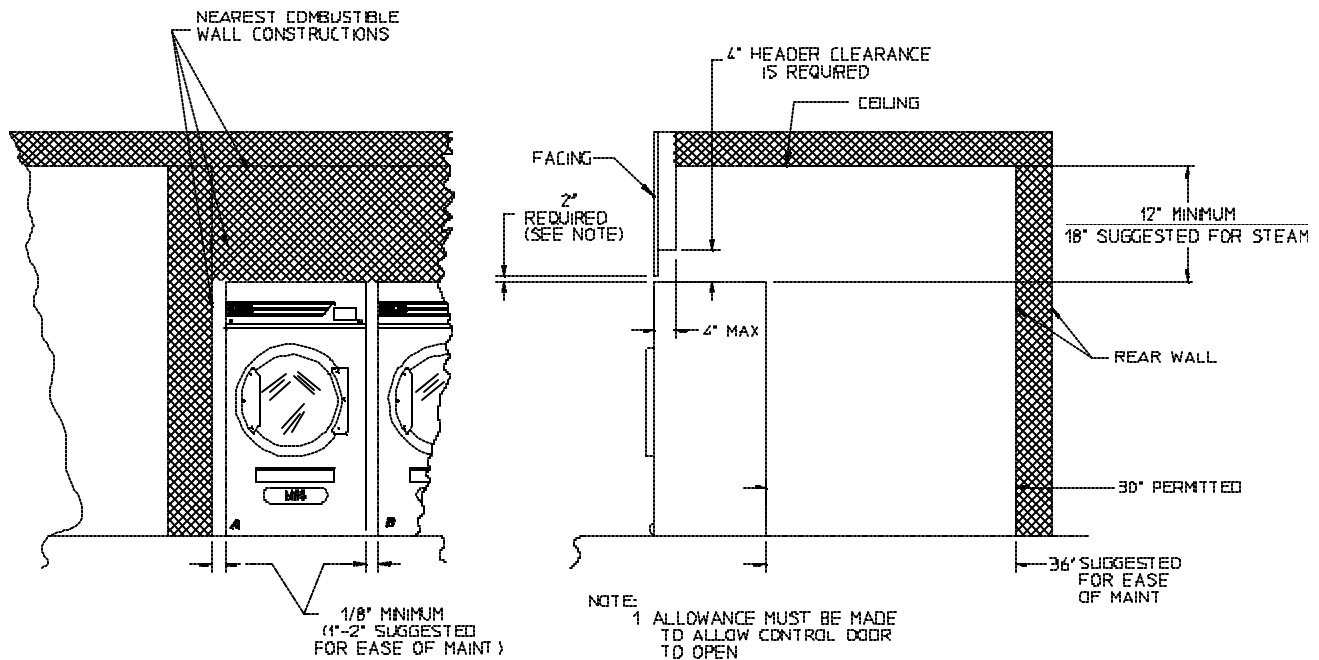

MAN4318

INSTALLATION DRYER CLEARANCE TO ADJACENT WALL STRUCTURES.

D. FRESH AIR SUPPLY

When the dryer is operating, it draws in room air, heats it, passes this air through the basket (tumbler), and exhausts it out of the building. Therefore, the room air **must be** continually replenished from the outdoors. If the make-up air is inadequate, drying time and drying efficiency will be adversely affected. Ignition problems and sail switch "fluttering" problems may result, as well as premature motor failure from overheating.

Air supply (make-up air) **must be** given careful consideration to assure proper performance of each dryer. An unrestricted source of air is necessary for each dryer. An air flow of 2,700 cfm (cubic feet per minute) **must be** supplied to each dryer. As a general rule, an unrestricted air entrance from the outdoors (atmosphere) of a minimum of 3 square feet is required for each dryer.

To compensate for the use of registers or louvers used over the openings, this makeup air **must be** increased by approximately thirty-three percent (33%). Makeup air openings **should not be** located in an area directly near where exhaust vents exit the building.

It is not necessary to have a separate makeup air opening for each dryer. Common makeup air openings are acceptable. However, they **must be** set up in such a manner that the makeup air is distributed equally to **ALL** the dryers.

EXAMPLE: For a bank of six (6) dryers, two (2) unrestricted openings measuring 3 feet by 3 feet (18 square feet) is acceptable.

Allowances **must be** made for remote or constricting passageways or where dryers are located at excessive altitudes or predominantly low pressure areas.

IMPORTANT: Make-up air **must be** provided from a source free of dry cleaning solvent fumes. Make-up air that is contaminated by dry cleaning solvent fumes will result in irreparable damage to motors and other dryer components.

NOTE: Component failure due to dry cleaning solvent fumes will VOID THE WARRANTY.

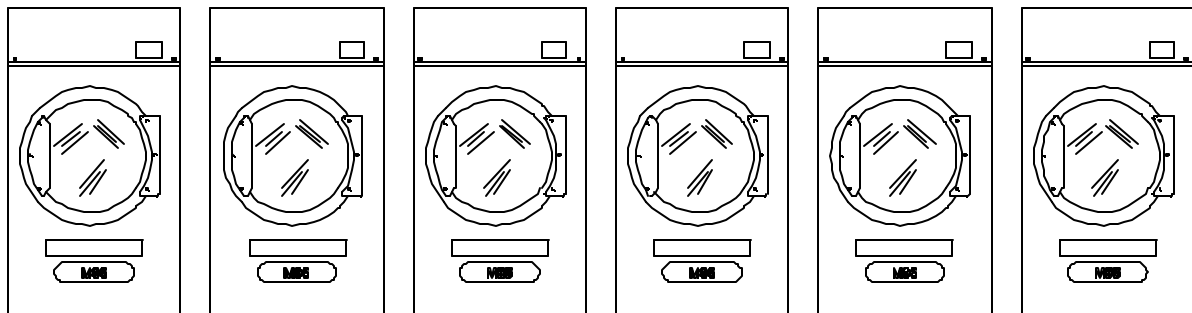

MAN4213

TYPICAL INSTALLATION SHOWING MAKE-UP AIR OPENINGS

E. EXHAUST REQUIREMENTS

1. General Exhaust Duct Work Information

Exhaust duct work **should be** designed and installed by a qualified professional. Improperly sized duct work will create excessive back pressure which results in slow drying, increased use of energy, overheating of the dryer, and shut down of the burner by the airflow (sail) switches, burner hi-limits, or basket (tumbler) hi-heat thermostats.

CAUTION: DRYER ***MUST BE*** EXHAUSTED TO THE OUTDOORS.

CAUTION: **IMPROPERLY SIZED OR INSTALLED EXHAUST DUCT WORK CAN CREATE A POTENTIAL FIRE HAZARD.**

NOTE: When a dryer is exhausted separately, it is recommended that a back draft damper be installed.

NOTE: When dryers are exhausted into multiple (common) exhaust lines, each dryer ***must be*** supplied with a back draft damper.

The duct work **should be** laid out in such a way that the duct work travels as directly as possible to the outdoors with as few turns as possible. Single or independent dryer venting is recommended. When single dryer venting is used, the duct work from the dryer to the outside exhaust outlet **should not** exceed twenty (20) feet. In the case of multiple (common) dryer venting, the distance from the last dryer to the outside exhaust outlet **should not** exceed twenty (20) feet. The shape of the duct work is not critical so long as the minimum cross section area is provided. It is suggested that the use of 90° turns in ducting be avoided; use 30° or 45° angles instead. The radius of the elbows should preferably be 1-1/2 times the diameter of the duct. Excluding basket or dryer elbow connection in the exhaust duct run. If more than two (2) elbows are used, the cross section area of the duct work **must be** increased in proportion to the number of elbows added.

ALL duct work should be smooth inside with no projections from the sheet metal screws or other obstructions which will collect lint. When adding ducts, the duct to be added should overlap the duct to which it is to be connected. **ALL** duct work joints must be taped to prevent moisture and lint from escaping into the building. Inspection doors should be installed at strategic points in the exhaust duct work for periodic inspection and clean-out of lint from the duct work.

IMPORTANT: Exhaust back pressure measured by a manometer at each basket duct area ***should not*** exceed .3 inches of water column.

IMPORTANT: Where the exhaust duct work passes through a wall, ceiling, or roof made of combustible materials, the opening ***must be*** 2-inches larger (all the way around) than the duct. The duct ***must be*** centered within this opening.

a. Outside Duct Work Protection

- 1) To protect the outside end of horizontal duct work from the weather, a 90° elbow bent downward **should be** installed where the exhaust exits the building. If the duct work travels vertically up through the roof, it **should be** protected from the weather by using a 180° turn to point the opening downward. In either case, allow at least twice the diameter of the duct between the duct opening and the nearest obstruction.

IMPORTANT: ***DO NOT*** use screens or caps on the outside of opening of exhaust duct work.

VERTICAL DUCTING

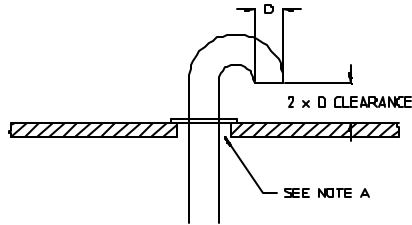

HORIZONTAL DUCTING

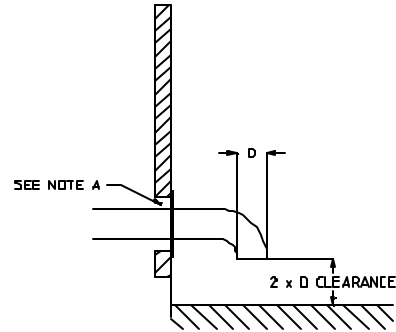

NOTE 'A' OPENING MUST BE TWO (2) INCHES LARGER THAN DUCT (ALL THE WAY AROUND) THE DUCT MUST BE CENTERED WITHIN THIS OPENING

MAN0731

2. Single Dryer Venting

Where possible, it is suggested to provide a separate exhaust duct for each dryer. The exhaust duct **should be** laid out in such a way that the duct work travels as directly as possible to the outdoors with as few turns as possible. It is suggested that the use of 90° turns in the ducting be avoided; use 30° or 45° angles instead. The shape of the exhaust duct work is not critical so long as the minimum cross section area is provided.

IMPORTANT: Minimum duct size for a dryer is 16-inches for a round duct or 14.25-inches for a square duct. Duct size **must not be** reduced anywhere down stream of dryer.

IMPORTANT: Exhaust back pressure measured by a manometer at each basket (tumbler) exhaust duct area **should not** exceed 0.3 inches of water column (W.C.).

It is suggested that the duct work from each dryer be a minimum of 16-inches for horizontal runs with no more than one (1) elbow and 18-inches for vertical runs with no more than three (3) elbows without exceeding twenty (20) feet (excluding dryer connections and outside exhaust outlets). If the duct exceeds twenty (20) feet or has numerous elbows, the cross section area of the duct work **must be** increased in proportion to the length and number of elbows in it. In calculating duct size, the cross section area of a square or rectangular duct **must be** increased by twenty (20) percent for each additional twenty (20) feet. The diameter of a round exhaust duct **should be** increased ten (10) percent for each additional fifteen (15) feet. Each 90° elbow is equivalent to an additional thirty-six (36) feet, and each 45° elbow is equivalent to an additional eighteen (18) feet.

SINGLE DRYER VENTING

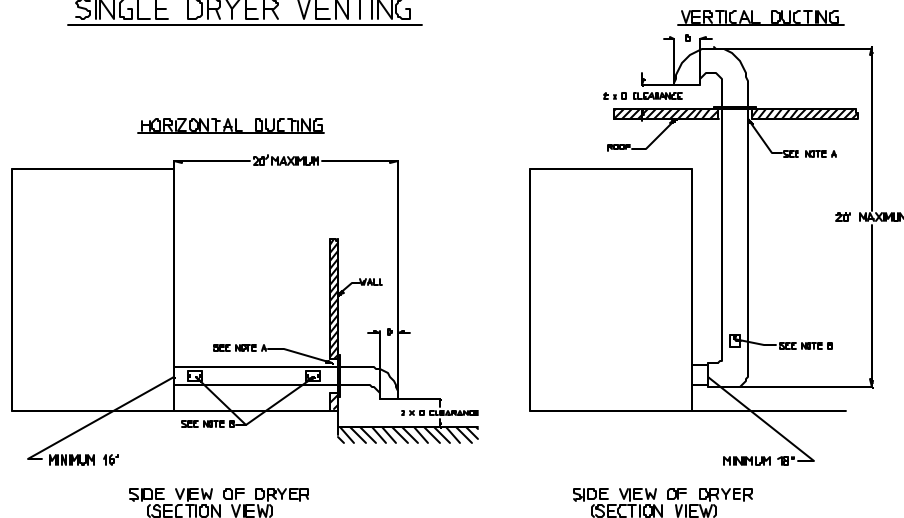

NOTE: 'A'- OPENING MUST BE TWO (2) INCHES LARGER THAN DUCT (ALL THE WAY AROUND). THE DUCT MUST BE CENTERED WITHIN THIS OPENING
 'B'- INSPECTION DOORS SHOULD BE INSTALLED AT STRATEGIC POINTS FOR PERIODIC INSPECTION AND CLEANING

MAN4210

IMPORTANT: For extended duct work runs, the cross section area of the duct work can only be increased to an extent. Maximum proportional duct work runs **cannot** exceed twenty (20) feet more than the original limitations of twenty (20) feet with one (1) elbow for horizontal runs and three (3) elbows for vertical runs. When the duct work approaches the maximum limits as noted in this manual, a professional heating, venting and air conditioning (HVAC) firm **should be** consulted for proper venting information.

ALL duct work **should be** smooth inside with no projections from sheet metal screws or other obstructions which will collect lint. When adding ducts, the duct to be added should overlap the duct to which it is to be connected. **ALL** duct work joints **must be** taped to prevent moisture and lint from escaping into the building. Inspection doors **should be** installed at strategic points in the exhaust duct work for periodic inspection and clean-out of lint from the duct work.

NOTE: Where the exhaust duct passes through a wall, ceiling, or roof made of combustible materials, the opening **must be** 2 inches larger (all the way around) than the duct. The duct **must be** centered within this opening.

a. Outside Duct Work Protection

- 1) To protect the outside end of horizontal duct work from the weather, a 90° elbow bent downward **should be** installed where the exhaust exits the building. If the duct work travels vertically up through the roof, it **should be** protected from the weather by using a 180° turn to point the opening downward. In either case, allow at least twice the diameter of the duct between the duct opening and the nearest obstruction.

IMPORTANT: **DO NOT** use screens or caps on the outside of opening of exhaust duct work.

3. Multiple Dryer (common) Venting

If it is not feasible to provide separate exhaust ducts for each dryer, ducts from individual dryers may be channeled into a "common main duct." The individual ducts should enter the bottom or side of the main duct at an angle not more than 45° in the direction of air flow and **should be** spaced at least 46 inches apart. The main duct **should be** tapered, with the diameter increasing before each individual duct (16 inch minimum) is added.

IMPORTANT: The ML-96HS is shipped with a 16-inch butterfly damper in the drum. The damper **must be** installed at each dryer duct.

IMPORTANT: No more than three (3) dryers **should be** connected to main common duct.

The main duct may be any shape so long as the minimum cross sect is provided. The illustration on **page 18** shows the minimum cross section area for multiple dryer round or square venting. These figures **must be** increased 10 square inches when rectangular main ducting is used, and the ration of duct width to depth **should not** be greater than 3-1/2 to 1. These figures **must be** increased in proportion if the main duct run from the last dryer to where it exhausts to the outdoors is unusually long (over twenty [20] feet) or has numerous (more than two [2] elbows in it). In calculating duct work size, the cross section area of a square or rectangular duct must be increased twenty (20) percent for each additional twenty (20) feet. The diameter of a round exhaust **must be** increased ten (10) percent for each additional twenty (20) feet. Each 90° elbow is equivalent to an additional thirty-six (36) feet and each 45° elbow is equivalent to an additional fifteen (18) feet.

IMPORTANT: For extended duct work runs, the cross section area of the duct work can only be increased to an extent. Maximum proportional duct work runs **cannot** exceed fifteen (15) feet with two (2) elbows. When the duct work approaches the maximum limits as noted in this manual, a professional HVAC firm **should be** consulted for proper venting. HVAC **should be** consulted for proper venting information.

IMPORTANT: Exhaust back pressure measured by a manometer at each dryer exhaust duct area **should not** exceed .3 inches of water column (W.C.).

The duct work **should be** smooth inside with no projections from sheet metal screws or other obstructions which will collect lint. When adding ducts, the duct to be added should overlap the duct to which it is to be connected. **ALL** duct work joints **must be** taped to prevent moisture and lint from escaping into the building. Inspection doors **should be** installed at strategic points in the exhaust duct work for periodic inspection and clean-out of lint from the duct work.

NOTE: Where the exhaust passes through a wall, ceiling, or roof made of combustible materials, the opening **must be** 2 inches larger (all the way around) than the duct. The duct **must be** centered within this opening.

a. Outside Duct Work Protection

- 1) To protect the outside end of horizontal duct work from weather, a 90° elbow bent downward **should be** installed where the exhaust exits the building. If the duct work travels vertically up through the roof, it **should be** protected from the weather by using a 180° turn to point the opening downward. In either case, allow at least twice the diameter of the duct between the duct opening and the nearest obstruction.

IMPORTANT: **DO NOT** use screens or caps on the outside of opening of exhaust duct work.

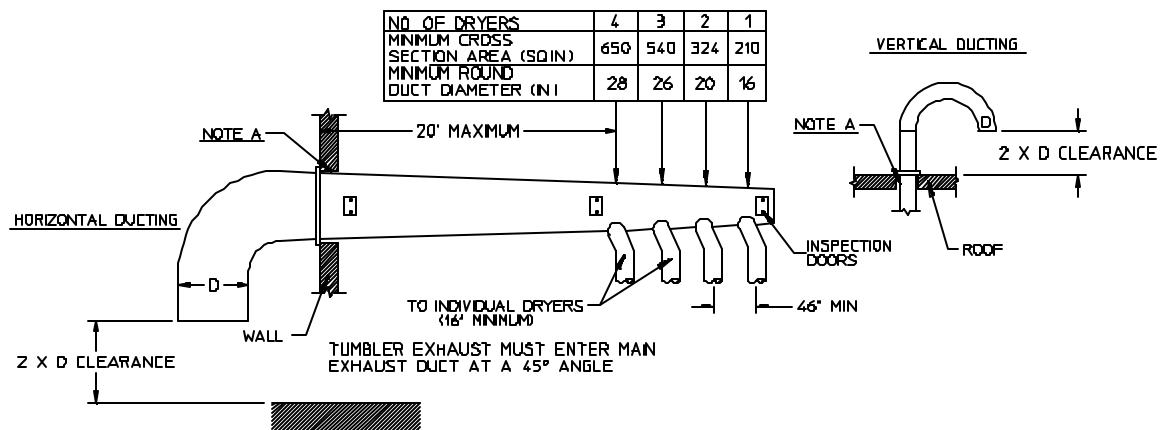

IMPORTANT NO MORE THAN 4 DRYERS CAN BE CONNECTED TO ONE COMMON DUCT (VENT)

FORMULAS TO CALCULATE DUCTING CROSS SECTIONAL AREA

CROSS SECTIONAL AREA OF A ROUND DUCT = $785 \times D^2$ WHERE D = DIAMETER OF THE DUCT

CROSS SECTIONAL AREA OF A RECTANGULAR DUCT = $W \times H$ WHERE W = WIDTH AND H = HEIGHT

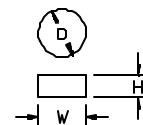

NOTE A OPENING MUST BE TWO (2) INCHES LARGER THAN DUCT (ALL THE WAY AROUND) THE DUCT MUST BE CENTERED WITHIN THIS OPENING

F. ELECTRICAL INFORMATION

1. Electrical Requirements

It is your responsibility to have **ALL** electrical connections made by a properly licensed and competent electrician to assure that the electrical installation is adequate and conforms with local and state regulations or codes. In the absence of such codes, **ALL** electrical connections, material, and workmanship **must conform** to the applicable requirements of the National Electrical Code ANSI/NFPA NO.70-LATEST EDITION, or in CANADA, the Canadian Electrical Codes Parts 1 & 2 CSA2.1-1990 or LATEST EDITION.

IMPORTANT: Failure to comply with these codes or ordinances, or the requirements stipulated in this manual can result in personal injury or component failure.

NOTE: Component failure due to improper installation will VOID THE WARRANTY.

Each dryer **should be** connected to an independently protected branch circuit. The dryer **must be** connected with copper wire only. ***DO NOT use aluminum wire which could cause a fire hazard.*** The copper conductor wire or cable **must be** of proper ampacity and insulation in accordance with electric codes for making **ALL** service connections.

NOTE: The use of aluminum wire will VOID THE WARRANTY.

IMPORTANT: Wiring diagrams are affixed to the inside at the top front control door and to the rear upper back guard or panel.

2. Electrical Service Specifications

MLG-96HS (NATURAL GAS)							
ELECTRICAL SERVICE SPECIFICATIONS (PER DRYER)*							
SERVICE VOLTAGE	PHASE	WIRE SERVICE	MINIMUM WIRE SIZE**	APPROX. AMP DRAW		CIRCUIT BREAKER	
				60 Hz	50 Hz	60 Hz	50 Hz
208	3 ϕ	3/4	12	13.5	--	25	--
240	3 ϕ	3	12	12.5	--	25	--
380-400	3 ϕ	3/4	14	--	6.9	--	15
416	3 ϕ	3/4	14	--	6.6	--	15
460/480	3 ϕ	3/4	14	6.8	--	15	--

* Contact factory for information not listed.

** AWG Stranded Type Wire...for individual lengths less than 100 feet. (Motor lead wire is recommended.)

IMPORTANT: The dryer *must be* connected to the electric supply shown on the data label that is affixed to the back side of the upper or top control door. In the case of 208 VAC or 230/240 VAC, the supply voltage *must match* the electric service specifications of the data label exactly.

IMPORTANT: The wire size *must be* properly sized to handle the related current.

WARNING: **208 VAC and 230/240 VAC ARE NOT THE SAME.** Any damage done to dryer components due to improper voltage connections will automatically VOID THE WARRANTY.

NOTE: ADC reserves the right to make changes in specifications at any time, without notice or obligation.

3. Grounding

A ground (earth) connection **must be** provided and installed in accordance with state and local codes. In the absence of these codes, grounding must conform to applicable requirements of the National Electric Code ANSI/NFPA NO. 70-LATEST EDITION, or in CANADA, the Canadian Electrical Codes Parts 1 & 2 CSA C22.1-1990 or LATEST EDITION. The ground connection may be to a proven earth ground at the location service panel.

NOTE: A grounding connection (terminal lug) is provided in the dryers electrical service box at rear.

For added personal safety, when possible, it is suggested that a separate ground wire (no. 18 minimum) be connected from the ground connection of the dryer to a grounded cold water pipe. **DO NOT** ground to a gas pipe or hot water pipe. The grounded cold water pipe must have metal to metal connection all the way to the electrical ground. If there are any nonmetallic interruptions, such as, a meter, pump, plastic, rubber, or other insulating connectors, they **must be** jumped out with no. 4 copper wire and securely clamped to bare metal at both ends.

IMPORTANT: For personal safety and proper operation, the dryer **must be** grounded. For proper operation of the microprocessor (computer), an earth (zero) ground is required.

NOTE: Grounding via metallic electrical conduit (pipe) **is not** recommended.

4. Electrical Connections

NOTE: A wire diagram is located in the front electrical control box for connection data.

The only electrical input connections to the dryer are the 3-phase (3 ϕ) power leads (L1, L2 and L3), GROUND, and in the case of 4 wire service, the neutral. Providing local codes permit, power connections to the dryer can be made by the use of flexible underwriters laboratory listed cord or pigtail (wire size **must conform** to rating of the dryer), or the dryer can be hard wired directly to the service breaker. In **ALL** cases, a strain relief **must be** used where the wires enter the dryer electrical service (relay) box.

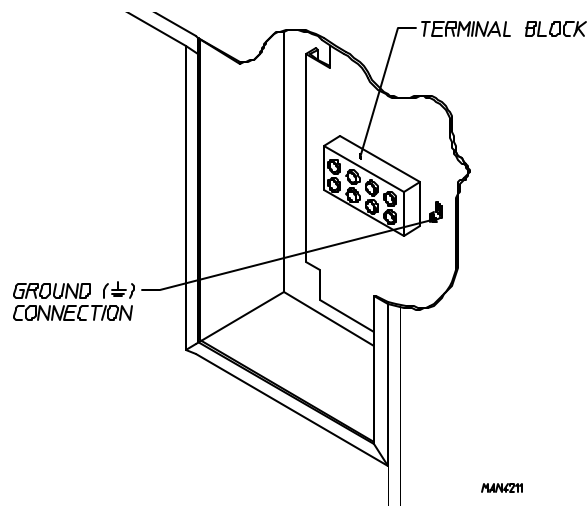

These electrical connections are made at the terminal block located in the electric service box at the rear, upper right hand corner of the dryer. To gain access into this service box, the service cover **must be** removed.

NOTE: A CIRCUIT SERVICING EACH DRYER **MUST BE** PROVIDED.

G. GAS INFORMATION

It is your responsibility to have **ALL** plumbing connections made by a qualified professional to assure that the gas plumbing installation is adequate and conforms with local and state regulations or codes. In the absence of such codes, **ALL** plumbing connections, materials, and workmanship **must conform** to the applicable requirements of the National Fuel Gas Code ANSI Z223.1-LATEST EDITION, or in CANADA, the Canadian Installation Codes CAN/CGA-B149.1-M91 (Natural Gas) or CAN/CGA-B149.2-M91 (L.P. Gas) or LATEST EDITION.

IMPORTANT: Failure to comply with these codes or ordinances, and/or the requirements stipulated in this manual, CAN RESULT IN PERSONAL INJURY and IMPROPER OPERATION OF THE DRYER.

The dryer and its individual shut-off valves **must be** disconnected from the gas supply piping system during any pressure testing of that system at test pressures in excess of 1/2 psig (3.5 kPa). The dryer **must be** isolated from the gas supply piping system by closing its individual manual shut-off valve during any pressure test of the gas supply system at test pressures equal to or less than 1/2 psig (3.5 kPa).

IMPORTANT: Failure to isolate or disconnect the dryer from supply as noted can cause irreparable damage to the gas valve which will VOID THE WARRANTY.

WARNING: FIRE or EXPLOSION COULD RESULT.

1. Gas Supply

The gas dryer installation **must meet** the American National Standard National Fuel Gas Code ANSI Z223.1-LATEST EDITION, or in CANADA, the Canadian Installation Codes CAN/CGA-B149.1-M91 (Natural Gas) or CAN/CGA-B149.2-M91 (L.P. Gas) or LATEST EDITION, as well as local codes and ordinances and **must be** done by a qualified professional.

NOTE: Undersized gas piping will result in ignition problems, slow drying, increased use of energy, and can create a safety hazard.

The dryer **must be** connected to the type of heat or gas indicated on the dryer label affixed behind the right control box door. If this information does not agree with the type of gas available, **DO NOT operate the dryer**. Contact the reseller who sold the dryer or the **ADC** factory.

IMPORTANT: Any burner changes or conversions **must be** made by a qualified professional.

The input ratings shown on the dryer data label are for elevations up to 2,000 feet, unless elevation requirements of over 2,000 feet were specified at the time the dryer order was placed with the factory. The adjustment or conversion of dryers in the field for elevations over 2,000 feet are made by changing each burner orifice. If this conversion is necessary, contact the reseller who sold the dryer or contact the **ADC** factory.

2. Technical Gas Data

a. Gas Specifications

	Type of Gas
	Natural
Manifold Pressure*	3.5 inches W.C.
Inline Pressure	6.0 - 12.0 inches W.C.

* Measured at gas valve pressure tap when gas valve is on.

b. Gas Connections

Inlet connection ----- 1" inch N.P.T.
 Inlet supply size ----- 1" inch N.P.T. (minimum)
 Btu/hr input (per dryer) ----- 310,000

1) Natural Gas

Regulation is controlled by the dryer's gas valve's internal regulator. Incoming supply pressure **must be** consistent between a minimum of 6.0 inches and a maximum of 12.0 inches water column (W.C.) pressure.

		Type of Gas		
		Natural		
Model Number	BTU Per Hour Rating	Qty.	D.M.S.*	Part Number
ML-96HS	350,000	3	#10	140836

* D.M.S. (Drill Material Size) equivalents are as follows:

Natural Gas .. #10 = .1935

3. Piping and Connections

ALL components and materials **must conform** to National Gas Code specifications, or in CANADA, the Canadian Installation Codes (for General Installation and Gas Plumbing). It is important that gas pressure regulators meet applicable pressure requirements and that gas meters be rated for the total amount of **ALL** the appliance BTU's being supplied.

The dryer is provided with a 1" N.P.T. inlet pipe connection located at the right side of the base of the dryer. The minimum pipe size (supply line) to the dryer is 1" N.P.T. For ease in servicing, the gas supply line of each dryer **must have** its own shut-off valve.

The size of the main gas supply line (header) will vary depending on the distance this line travels from the gas meter, or if other gas-operated appliances are on the same line, etc. Specific information regarding supply line size **should be** determined by the gas supplier.

NOTE: Undersized gas supply piping can create a low or inconsistent pressure which will result in erratic operation of the burner ignition system.

TYPICAL NATURAL GAS INSTALLATION

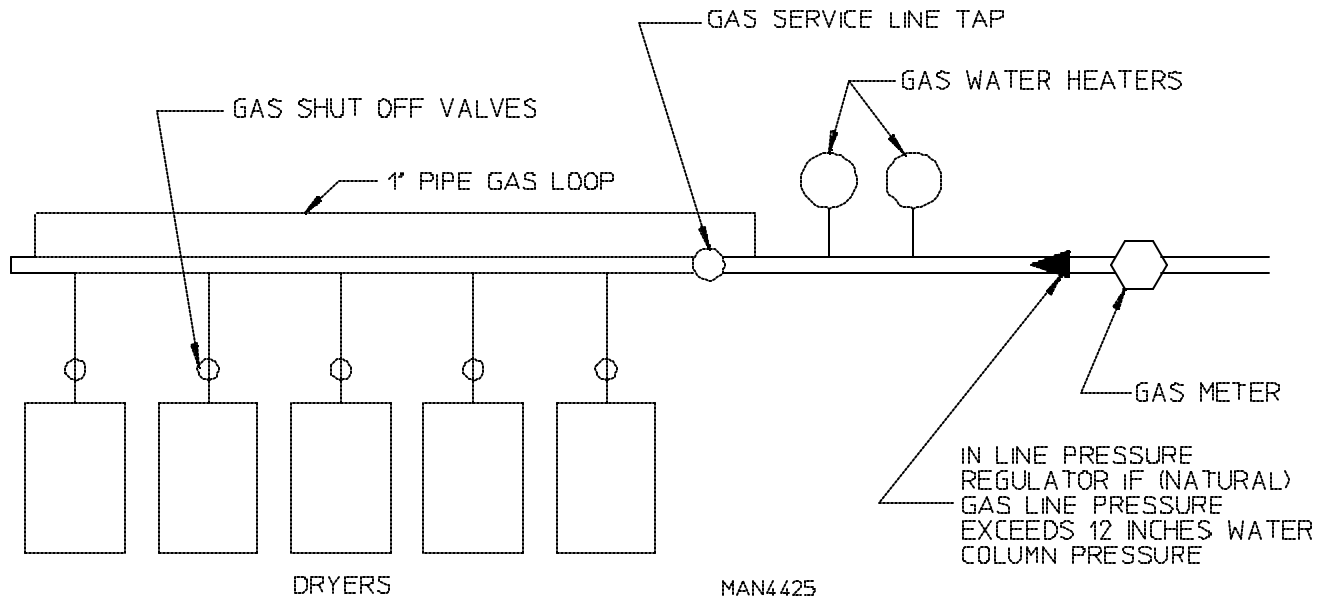

Consistent gas pressure is essential at **ALL** gas connections. It is recommended that a 1-inch pipe gas loop be installed in the supply line serving a bank of dryers. An in-line pressure regulator **must be** installed in the gas supply line (header) if the (natural) gas pressure exceeds 12.0 inches of water column (W.C.) pressure.

NOTE: A water column test pressure of 3.5 inches for natural gas dryers is required at the gas valve pressure tap of each dryer for proper and safe operation.

A 1/8" N.P.T. plugged tap, accessible for a test gauge connection, **must be** installed in the main gas supply line immediately upstream of each dryer.

IMPORTANT: Pipe joint compounds that resist the action of natural gas **must be** used.

IMPORTANT: Test **ALL** connections for leaks by brushing on a soapy water solution (liquid detergent works well).

WARNING: NEVER TEST FOR LEAKS WITH A FLAME!!

ALL components and materials **must conform** to National Gas Code specifications, or in CANADA, the Canadian Installation Codes CAN/CGA-B149.1-M91 (Natural Gas) or CAN/CGA-B149.2-M91 (L.P. Gas) or LATEST EDITION. It is important that gas pressure regulators meet applicable pressure requirements and that gas meters be rated for the total amount of **ALL** the appliance BTU's being supplied.

IMPORTANT: The dryer and its individual shut-off valve **must be** disconnected from the gas supply piping system during any pressure testing of that system at test pressures in excess of 1/2 psig (3.5 kPa).

NOTE: The dryer **must be** isolated from the gas supply piping system by closing its individual manual shut-off valve during any pressure test of the gas supply system at test pressures equal to or less than 1/2 psig (3.5 kPa).

H. PREPARATION FOR OPERATION AND START-UP

The following items **should be** checked before attempting to operate the dryer:

1. Read **ALL** "**CAUTION**," "**WARNING**," and "**DIRECTION**" labels attached to the dryer.
2. Check incoming supply voltage to be sure that it is the same as indicated on the dryer data label affixed to the back side of the top front control and service door. In the case of 208 VAC or 230/240 VAC, **THE SUPPLY VOLTAGE MUST MATCH THE ELECTRIC SERVICE EXACTLY**.
3. Check to assure that the dryer is connected to the type of heat or gas indicated on the dryer data label.
4. The sail switch damper assembly was installed and adjusted at the factory prior to shipping. However, each sail switch adjustment **must be** checked to assure that this important safety control is functioning.
5. Be sure that **ALL** gas shut-off valves are in the open position.
6. Be sure **ALL** side and base panels are on the dryer.

7. Check **ALL** service doors to insure that they are closed and secure.
8. Be sure the lint drawer is securely in place.

NOTE: LINT DRAWER *MUST BE* CLOSED TO ACTIVATE SAFETY SWITCH OTHERWISE THE DRYER WILL NOT START.

9. Rotate the basket (tumbler or drum) by hand to be sure it moves freely.
10. Check bolts, nuts, screws, terminals and fittings for security.
11. Check tumbler bearing set screws to insure they are **ALL** tight.

I. PREOPERATIONAL TESTS

ALL dryers are thoroughly tested and inspected before leaving the factory. However, a preoperational test **should be** performed before the dryer is publicly used. It is possible that adjustments have changed in transit or due to marginal location (installation) conditions.

1. Turn on electric power to the dryer.
2. Make sure the main door and lint door are closed.
3. Refer to the operating instructions for starting your particular model dryer.
4. Check to ensure the basket (tumbler) starts in the clockwise (CW) direction. Additionally, check the direction of the blower motor impellor (fan) to ensure the impellor (fan) rotates in the clockwise (CW) position as viewed from the front. If it is, the phasing is correct. If the phasing is incorrect, reverse two (2) of the leads at L1, L2 or L3 of the power supply connections made to the dryer.

IMPORTANT: Dryer blower motor impellor and fan as viewed from above ***must turn*** in the clockwise (CW) direction, otherwise dryer efficiency will drastically be reduced and premature component failure can result.

HEAT CIRCUIT OPERATIONAL TEST

a. Gas Models

1. When the dryer is first started (during initial start-up), the burner has a tendency not to ignite on the first attempt. This is because the gas supply piping is filled with air, so it may take a few minutes for this air to be purged from the lines.
2. The dryer is equipped with a Hot Surface Ignition (HSI) system which has internal diagnostics. If ignition **is not** established after the first attempt, the computer will go into retry mode. If ignition **is not** established after two (2) retries, no heat condition occurs.

NOTE: During the purging period, check to be sure **ALL** gas shut-off valves are open.

3. Once ignition is established, a gas pressure test **should be** taken at the gas valve pressure tap of each dryer to assure that the water column pressure (W.C.) is correct and consistent.

b. Microprocessor (computer) Dryer Models

1. Spin and stop times **are not** adjustable in the Automatic Mode and have been preprogrammed into the microprocessor controller (computer) for 120 seconds spin time and a 5 second dwell (stop) time.
2. Spin and stop times are adjustable in the Manual (timed) Mode.

J. OPERATING INSTRUCTIONS

NOTE: Before attempting to start the dryer make sure the main door is closed and the lint drawer is securely in place.

1. To start the dryer:

a. Microprocessor (computer) Dryers

1. Display will read "READY" (no cycle in progress).
2. Press the letter on the keyboard (touchpad) corresponding to the cycle desired (i.e., Key "E"). Dryer will start to rotate.
3. L.E.D. (light emitting diode) display will now toggle "Drying" "Manual" "Cycle E" "30 Min" "Remain" meaning the dryer is in the drying cycle and count down in minutes.

NOTE: Pressing touch pad key "A," "B," "C," "D," and "F" will also start the dryer. The six (6) preprogrammed drying cycles ("A" through "F") have been stored in the microprocessor (computer's) memory. Refer to the Computer Programming Manual supplied with dryer for more specific operating information.

NOTE: The dryer can be stopped at any time by opening main door or by pressing the "STOP" key. To restart the dryer, press the "START" key or preprogrammed cycle key (i.e., "E").

NOTE: Selection (setting) changes can be made at any time during the drying cycle by pressing the "CLEAR/STOP" key twice. The L.E.D. display will return to "READY" at which time a new cycle selection can be made.

K. SHUT DOWN INSTRUCTIONS

If the dryer is to be shut down (taken out of service) for a period of time, the following **must be** performed:

1. Discontinue power to the dryer either at the external disconnect switch or the circuit breaker.
2. Discontinue the gas supply:
 - a. **SHUT OFF** external gas supply shut-off valve.
 - b. **SHUT OFF** internal gas supply shut-off valve located in the gas valve train area.

SECTION IV

SERVICE and PARTS INFORMATION

A. SERVICE

1. Service **must be** performed by a qualified trained technician, service agency, or gas supplier. If service is required, contact the reseller from whom the **ADC** equipment was purchased. If the reseller **cannot** be contacted or is unknown, contact the **ADC** Service Department for a reseller in your area.

NOTE: When contacting the **ADC** Service Department, be sure to give them the correct **model number** and **serial number** so that your inquiry is handled in an expeditious manner.

B. PARTS

1. Replacement parts should be purchased from the reseller from whom the **ADC** equipment was purchased. If the reseller cannot be contacted or is unknown, contact the **ADC** Parts Department for a reseller in your area. Parts may also be purchased directly from the factory by calling the **ADC** Parts Department at (508) 678-9000 or you may FAX in your order at (508) 678-9447.

NOTE: When ordering replacement parts from the **ADC** dealer or the **ADC** factory be sure to give give them the correct **model number** and **serial number** so that your parts order can be processed in an expeditious manner.

SECTION V

WARRANTY INFORMATION

A. RETURNING WARRANTY CARD(S)

1. Before any dryer leaves the **ADC** factory test area, a warranty card (**ADC** Part No. 112254) is placed on the back side of the main door glass. These warranty cards are intended to serve the customer where we record the individual installation date and warranty information to better serve you, if you file a warranty claim.
 - a. If a warranty card (**ADC** Part No. 112254) did not come with your dryer, contact the **ADC** Warranty Department or **ADC** Service Department at (508) 678-9000.

B. PARTS

For a copy of the **ADC** commercial warranty covering your particular dryer(s), contact the **ADC** reseller from whom you purchased the equipment and request dryer warranty form **ADC** Part No. 450199. If the reseller **cannot** be contacted or is unknown, warranty information can be obtained from the factory by contacting the **ADC** Warranty Department at (508) 678-9000.

NOTE: Whenever contacting the **ADC** factory for warranty or warranty information, be sure to have the dryer's **model** and **serial numbers** available so that your inquiry can be handled in an expeditious manner.

C. RETURNING WARRANTY PARTS

ALL dryer or parts warranty claims or inquiries **should be** addressed to the **ADC** Warranty Parts Department. To expedite processing, the following procedures **must be** followed:

1. No parts are to be returned to **ADC** without prior written authorization ("Return Material Authorization") from the factory.

NOTE: An R.M.A. ("Return Material Authorization") is valid for only sixty (60) days from date of issue.

- a. The R.M.A. issued by the factory, as well as any other correspondence pertaining to the returned parts, **must be** included inside the package with the failed merchandise.

2. Each part **must be** tagged with the following information:
 - a. **Model number** and **serial number** of the dryer from which part was removed.
 - b. Nature of failure (be specific).
 - c. Date of dryer installation.
 - d. Date of part failure.
 - e. Specify whether the parts being returned is for a replacement, a credit, or a refund.

NOTE: If a part is marked for a credit or a refund, the invoice number covering the purchase of the replacement part **must be** provided.

NOTE: Warranty tags (ADC Part No. 450064) are available at "no charge" from ADC upon request.

3. The company returning the parts must clearly note the complete company name and address on the outside of the package.
4. **ALL** returns **must be** properly packaged to ensure that they are not damaged in transit. *Damage claims are the responsibility of the shipper.*

IMPORTANT: No replacements, credits or refunds will be issued for merchandise damaged in transit.

5. **ALL** returns **should be** shipped to the ADC factory in such a manner that they are insured and a proof of delivery can be obtained by the sender.
6. **Shipping charges are not the responsibility of ADC. ALL returns should be "prepaid" to the factory. Any "C.O.D." or "COLLECT" returns will not be accepted.**

IMPORTANT: No replacements, credits, or refunds will be issued if the claim *cannot* be processed due to insufficient information. The party filing the claim will be notified in writing, either by "FAX" or "CERTIFIED MAIL - Return Receipt Requested", as to the information necessary to process claim. If a reply is not received by the ADC Warranty Department within thirty (30) days from the FAX or letter date, then no replacement, credit, or refund will be issued, and the merchandise **will be discarded**.

SECTION VI

ROUTINE MAINTENANCE

A. CLEANING

A program or schedule **should be** established for periodic inspection, cleaning, and removal of lint from various areas of the dryer, as well as throughout the duct work system. The frequency of cleaning can best be determined from experience at each location. Maximum operating efficiency is dependent upon proper air circulation. The accumulation of lint can restrict this air flow. If the guidelines in this section are met, an **ADC** dryer will provide many years of efficient, trouble-free, and - most importantly safe operation.

WARNING: LINT FROM MOST FABRICS IS HIGHLY COMBUSTIBLE. THE ACCUMULATION OF LINT CAN CREATE A POTENTIAL FIRE HAZARD.

WARNING: KEEP DRYER AREA CLEAR AND FREE FROM COMBUSTIBLE MATERIALS, GASOLINE, and OTHER FLAMMABLE VAPORS and LIQUIDS.

NOTE: Suggested time intervals shown are for average usage which is considered six (6) to eight (8) operational (running) hours per day.

SUGGESTED CLEANING SCHEDULE

EVERY LOAD

Clean the lint screen after every load. A clogged lint screen will cause poor dryer performance. The lint screen is located behind the lint door in the base of the dryer. Open the lint door, brush the lint off the lint screen, and remove the lint. Inspect lint screen and replace if torn.

NOTE: The frequency of cleaning the lint screen can best be determined from experience at each location.

WEEKLY

Clean lint accumulation from lint chamber, thermostat, and microprocessor temperature sensor (sensor bracket) area.

WARNING: TO AVOID THE HAZARD OF ELECTRICAL SHOCK, DISCONTINUE ELECTRICAL SUPPLY TO THE DRYER.

WARNING: When cleaning steam coil fins, be careful not to bend the fins. If fins are bent, straighten by using a fin comb which is available from local air-conditioning supply house.

90 DAYS

1. Remove lint from around basket (tumbler), drive motors, and surrounding areas.
2. Remove lint from gas valve burner area with a dusting brush or vacuum cleaner attachment.
3. Clean any lint accumulation in and around both the blower and drive motor casing openings.

NOTE: To prevent damage, avoid cleaning or touching ignitor and flame-probe assembly.

EVERY 6 MONTHS

Inspect and remove lint accumulation in customer furnished exhaust duct work system and from dryers internal exhaust ducting. Drive and idler shaft bearings should be lubricated. Use a #3 grease or equivalent.

NOTE: THE ACCUMULATION OF LINT IN THE EXHAUST DUCT WORK CAN CREATE A POTENTIAL FIRE HAZARD.

NOTE: *DO NOT* OBSTRUCT THE FLOW OF COMBUSTION and VENTILATION AIR. CHECK BACK DRAFT DAMPERS IN THE EXHAUST DUCT WORK. INSPECT and REMOVE ANY LINT ACCUMULATION WHICH CAN CAUSE THE DAMPER TO BIND or STICK.

NOTE: A back draft damper that is sticking partially closed can result in slow drying and shut down of the heat circuit safety switches or thermostats.

NOTE: When cleaning the dryer cabinets, avoid using harsh abrasives. A product intended for the cleaning of appliances is recommended.

B. ADJUSTMENTS

7 DAYS AFTER INSTALLATION and EVERY 6 MONTHS THEREAFTER

Inspect bolts, nuts, screws, (bearing set screws), nonpermanent gas connections (unions, shut-off valves, orifices, and grounding connections). Motor and drive belts **should be** examined. Cracked or seriously frayed belts **should be** replaced. Tighten loose V-belts when necessary. Complete operational check of controls and valves. Complete operational check of **ALL** safety devices (door switches, lint drawer switch, sail switch, burner and hi-limit thermostats).

C. LUBRICATION

The drive shaft bearings and idler shaft bearings should be lubricated every six (6) months. Use a #3 grease or equivalent. **LUBRICATION IS NECESSARY.**

SECTION VII

PROCEDURE FOR FUNCTIONAL CHECK OF REPLACEMENT COMPONENTS

Hot Surface Ignition (HSI) System

- a. Upon completing installation of the replacement Hot Surface Ignition (HSI) module, reestablish power to the dryer.
- b. The HSI module's "red" indicator light will light up for approximately 5 seconds (self check routine). If the HSI module's "red" indicator light stays on or flashes continuously, then the HSI module is wired incorrectly or has failed.
- c. Start the drying cycle.
- d. The hot surface ignitor will turn on. After approximately 4 seconds the glo bar will shut off and the gas valve will be energized. ***The flame should now be established.***
- e. With the burner flame on, remove the flame sensor wire from the S2 terminal of the HSI module. ***The burner flame must shut off immediately.***
- f. Stop the drying cycle, with the flame sensor wire still removed, restart the drying cycle.
- g. The hot surface ignitor will turn on and after approximately 4 seconds the hot surface ignitor will shut off. The gas valve will be energized and a burner flame ***should be evident*** for approximately 7 seconds and then shut off.
- h. The HSI module will attempt two (2) additional ignition trails after which the HSI module will lock out and the "red" indicator light ***will flash continuously.***
- i. Functional check of the Hot Surface Ignition (HSI) module is complete. Replace the flame sensor wire from the S2 terminal to the HSI module.

