

brother[®]

Brother Laser Printer

HL-960 Series

USER'S GUIDE

Trademarks

Brother is a registered trademark of Brother Industries, Ltd.

Apple and LaserWriter are registered trademarks, and TrueType is a trademark of Apple Computer, Inc.

Centronics is a trademark of Genicom Corporation.

EPSON is a registered trademark, and FX-850 and FX-80 are trademarks of Seiko Epson Corporation.

Hewlett-Packard, HP and PCL are registered trademarks, and HP LaserJet 4, HP LaserJet Plus, HP LaserJet II, HP LaserJet IID, HP LaserJet IIID, HP-GL, HP-GL/2, and Bi-Tronics are trademarks of Hewlett-Packard Company.

IBM, Proprinter XL, Proprinter, and IBM/PC are registered trademarks of International Business Machines Corporation.

Intellifont is a registered trademark of AGFA Corporation, a division of Miles, Inc.

Microsoft and MS-DOS are registered trademarks of Microsoft Corporation.

Windows is a registered trademark of Microsoft in the U.S. and other countries.

PostScript is a registered trademark of Adobe Systems Incorporated.

All other brand and product names mentioned in this user's guide are registered trademarks or trademarks of respective companies.

Compilation and Publication

Under the supervision of Brother Industries Ltd., this manual has been compiled and published, covering the latest product descriptions and specifications.

The contents of this manual and the specifications of this product are subject to change without notice.

Brother reserves the right to make changes without notice in the specifications and materials contained herein and shall not be responsible for any damages (including consequential) caused by reliance on the materials presented, including but not limited to typographical and other errors relating to the publication.

©1994 Brother Industries Ltd.

Shipment of the Printer

If for any reason you must ship your Printer, carefully package the Printer to avoid any damage during transit. It is recommended that you save and use the original packaging. The Printer should also be adequately insured with the carrier.

✓WARNING

When shipping the Printer, the TONER CARTRIDGE must be removed from the Printer. **Failure to remove the Toner Cartridge during shipping, will cause severe damage to the Printer and will VOID THE WARRANTY.**



Laser Printer

HL-960 Series

USER'S GUIDE

(For USA & CANADA Only)

For technical and operational assistance, please call:

In USA	1-800-276-7746 (outside California) 714-859-9700 (within California)
In Canada	1-800-361-6466

If you have comments or suggestions, please write us at:

In USA	Printer Customer Support Brother International Corporation 15 Musick Irvine, CA 92718
In Canada	Brother International Corporation, Ltd. 1, Rue Hôtel De Ville Dollard-des-Ormeaux P.Q. Canada H9B3H6

BBS

For downloading drivers from our Bulletin Board Service, call 1-714-859-2610. Please logon to our BBS with your first name, last name and a four digit number for your password. Our BBS supports modem speeds up to 14,400, 8 bits no parity, 1 stop bit.

DEALERS/SERVICE CENTERS

For the name of an authorized dealer or service center, call 1-800-284-4357.

Definitions of Warnings, Cautions, and Notes

The following conventions are used in this User's Guide:



Warning

Indicates warnings that must be observed to prevent possible personal injury.



Caution

Indicates cautions that must be observed to use the printer properly or prevent damage to the printer.



Note

Indicates notes and useful tips to remember when using the printer.

To Use the Printer Safely



Warning

The fixing roller is extremely hot during operation. Remove the paper carefully.

TABLE OF CONTENTS

IMPORTANT INFORMATION: REGULATIONS.....	ix
CHAPTER 1 GENERAL.....	1-1
ABOUT THIS MANUAL.....	1-1
ABOUT CHAPTERS ON THE FLOPPY DISK.....	1-3
ABOUT THIS PRINTER	1-4
Features	1-4
Options	1-9
CHAPTER 2 GETTING STARTED	2-1
BEFORE USING THE PRINTER	2-1
Checking the Components.....	2-1
Printer Carton	2-1
Toner Cartridge.....	2-2
General View	2-3
Operating and Storage Environment	2-4
Power Supply	2-4
Environment.....	2-4
SETTING UP THE PRINTER.....	2-5
Opening and Closing the Printer.....	2-5
Removing the Protective Parts	2-6
Installing the Toner Cartridge.....	2-7
Loading Paper in the Paper Cassette.....	2-11
Connecting the Printer to Your Computer.....	2-17
Turning the Printer On and Off.....	2-19
Plugging in the Power Cord	2-19
Pressing the POWER Switch	2-20
Printing the Test Patterns or Lists	2-21
Checking the Printed Test Pattern.....	2-24

CHAPTER 3 BEFORE WORKING WITH THE PRINTER.....	3-1
SOFTWARE COMPATIBILITY.....	3-1
AUTOMATIC EMULATION SELECTION	3-3
AUTOMATIC INTERFACE SELECTION	3-5
ABOUT THE CONTROL PANEL.....	3-7
Adjusting the Control Panel Angle	3-7
Selecting the Local Language Display	3-8
Using the Panel Switches	3-9
Printer Settings.....	3-10
User Settings	3-10
Factory Settings.....	3-10
PAPER HANDLING	3-11
Print Media	3-11
Paper Size.....	3-11
Using Envelopes.....	3-13
Cassette Feed.....	3-15
Manual Feed	3-16
Face Down Print Delivery	3-17
Face Up Print Delivery.....	3-17
CHAPTER 4 CONTROL PANEL (DISK).....	4-1
DISPLAY AND LAMPS.....	4-1
Display	4-1
Printer Status Messages	4-2
Lamps.....	4-4
READY	4-4
DATA	4-4
ALARM	4-4
ON LINE.....	4-4

SWITCHES IN NORMAL MODE	4-5
SEL Switch.....	4-5
SET Switch.....	4-6
▲ (UP) or ▼ (DOWN) Switch	4-6
MODE Switch.....	4-7
MODE Switch Settings in HP LaserJet 4, EPSON FX-850, and IBM Proprinter XL Modes.....	4-8
MODE Switch Settings in HP-GL Mode	4-11
Basic Operation Procedures	4-13
Operation Example: Selecting the Parallel Interface	4-14
INTERFACE MODE	4-15
FORMAT MODE	4-18
ORIENTATION	4-18
AUTO MODE	4-19
PAGE FORMAT MODE	4-20
GRAPHICS MODE	4-23
RESOLUTION MODE	4-26
PAGE PROTECTION	4-28
CARD OPERATION	4-29
ADVANCED MODE	4-37
NETWORK MODE	4-37
CONTINUE MODE	4-40
PRINT DENSITY	4-41
INPUT BUFFER	4-41
SAVE SETTINGS	4-42
PAGE COUNTER	4-43
EXIT MODE	4-43
FONT Switch	4-44
Setting the Font and Symbol Set in the HP LaserJet 4 Mode	4-44
Setting the Font and Character Set in the EPSON FX-850, or IBM Proprinter XL Mode	4-49
List of Fonts	4-54
List of Symbol/Character Sets	4-55
FORM FEED Switch (REPRINT Switch).....	4-56
Form Feed	4-56
Reprint Function.....	4-56
CONTINUE Switch.....	4-58

SWITCHES IN SHIFT MODE	4-59
SHIFT Switch	4-59
EMULATION Switch	4-60
About Emulation Modes	4-62
ECONOMY Switch	4-64
POWER SAVE MODE	4-64
FEEDER Switch	4-65
FEEDER.....	4-65
MP FIRST	4-67
MANUAL FEED	4-68
MP TRAY SETTING	4-68
MEDIA TYPE	4-69
DUPLEX MODE.....	4-70
COPY Switch.....	4-72
RESET Switch	4-73
List of Factory Settings.....	4-74
TEST Switch.....	4-80
HEX DUMP MODE.....	4-83
CHAPTER 5 OPTIONS (DISK).....	5-1
LOWER TRAY UNIT (LT-1200).....	5-1
Loading Paper from the Lower Paper Cassette	5-1
FONT CARTRIDGE/CARD, FLASH MEMORY/HDD CARD	5-2
Installing a Font Cartridge/Card, Flash Memory Card and HDD Card.....	5-2
Selecting the Optional Fonts	5-4
RAM EXPANSION	5-6
DUPLEX UNIT (DX-1200).....	5-10

CHAPTER 6 MAINTENANCE (DISK)	6-1
MAINTENANCE.....	6-1
Toner Cartridge.....	6-1
Toner Empty Message.....	6-1
Replacing the Toner Cartridge.....	6-2
Cleaning.....	6-5
Cleaning the Printer Exterior.....	6-5
Cleaning the Printer Interior.....	6-6
 CHAPTER 7 TROUBLESHOOTING	 7-1
TROUBLESHOOTING.....	7-1
Operator Call Messages.....	7-1
Error Messages.....	7-3
Service Call Messages.....	7-5
Possible Troubles.....	7-6
Paper Jam.....	7-6
Unsatisfactory Printouts.....	7-12
 APPENDICES (DISK)	 Appendix-1
PRINTER SPECIFICATIONS.....	Appendix-1
Printing.....	Appendix-1
Functions.....	Appendix-2
Electrical and Mechanical.....	Appendix-3
PAPER SPECIFICATIONS.....	Appendix-4
INTERFACE SPECIFICATIONS.....	Appendix-8
Bi-directional Parallel Interface.....	Appendix-8
Pin Assignment.....	Appendix-8
Signal Description.....	Appendix-9
Parallel Cable Connection for IBM-PC/AT or	
Compatible Computers and IBM-PS/2 Computers.....	Appendix-10

USER'S GUIDE

RS-232C Serial Interface	Appendix-11
Standard Specifications.....	Appendix-11
Interface Connectors.....	Appendix-11
Pin Assignment.....	Appendix-11
Signal Description	Appendix-12
Serial Cable Connection for IBM-PC/AT or Compatible Computers and IBM-PS/2 Computers	Appendix-13
SYMBOL/CHARACTER SETS.....	Appendix-14
OCR Symbol Sets	Appendix-14
HP LaserJet 4 Mode	Appendix-15
EPSON Mode	Appendix-22
IBM Mode	Appendix-25
HP-GL Mode	Appendix-27
Symbol Sets Supported by the Printer's Intellifont Compatible Typefaces.....	Appendix-32
QUICK REFERENCE OF COMMANDS.....	Appendix-34
HP LaserJet 4 Mode	Appendix-34
PCL Command Sets.....	Appendix-34
CCIT G3/G4 and TIFF.....	Appendix-46
HP-GL/2 Command Sets	Appendix-48
Printer Job Language Commands Syntax	Appendix-50
EPSON FX-850 Mode.....	Appendix-51
IBM Proprinter XL Mode.....	Appendix-54
HP-GL Mode	Appendix-57
Bar Code Control.....	Appendix-59
Print Bar Codes or Expanded Characters	Appendix-59
INDEX	Index-1

IMPORTANT INFORMATION: REGULATIONS

Federal Communications Commission Compliance Notice (For U.S.A. only)

This equipment has been tested and found to comply with the limits for a Class B digital device, pursuant to Part 15 of the FCC Rules. These limits are designed to provide reasonable protection against harmful interference in a residential installation. This equipment generates, uses, and can radiate radio frequency energy and, if not installed and used in accordance with the instructions, may cause harmful interference to radio communications. However, there is no guarantee that interference will not occur in a particular installation. If this equipment does cause harmful interference to radio or television reception, which can be determined by turning the equipment off and on, the user is encouraged to try to correct the interference by one or more of the following measures:

- Reorient or relocate the receiving antenna.
- Increase the separation between the equipment and receiver.
- Connect the equipment into an outlet on a circuit different from that to which the receiver is connected.
- Consult the dealer or an experienced radio/TV technician for help.

Important – About the Interface Cable

This printer has been certified to comply with FCC standards, which are applied to the U.S.A. only. A shielded interface cable should be used according to FCC 15.27(C). In addition, a grounded plug should be plugged into a grounded AC outlet after checking the rating of the local power supply for the printer to operate properly and safely.

⚠ Caution

Changes or modifications not expressly approved by Brother Industries, Ltd. could void the user's authority to operate the equipment.

Canadian Department of Communications Compliance Statement (For Canada only)

This digital apparatus does not exceed the Class B limits for radio noise emissions from digital apparatus as set out in the interference-causing equipment standard entitled "Digital Apparatus", ICES-003 of the Department of Communications.

Avis de conformité aux normes du ministère des Communications du Canada (Pour Canada Seul)

Cet appareil numérique respecte les limites de bruits radioélectriques applicables aux appareils numériques de Classe B prescrites dans la norme sur le matériel brouilleur : "Appareils Numériques", NMB-003 édictée par le ministère des Communications.

Laser Safety (110-120 V model only)

This printer is certified as a Class I laser product under the U.S. Department of Health and Human Services (DHHS) Radiation Performance Standard according to the Radiation Control for Health and Safety Act of 1968. This means that the printer does not produce hazardous laser radiation.

Since radiation emitted inside the printer is completely confined within protective housings and external covers, the laser beam cannot escape from the machine during any phase of user operation.

CDRH Regulations (110-120 V model only)

The Center for Devices and Radiological Health (CDRH) of the U.S. Food and Drug Administration (FDA) implemented regulations for laser products on August 2, 1976. These regulations apply to laser products manufactured from August 1, 1976. Compliance is mandatory for products marketed in the United States. The label shown on the back of the printer indicates compliance with the CDRH regulations and must be attached to laser products marketed in the United States.

<p>MANUFACTURED: BROTHER INDUSTRIES, LTD. 15-1 Naeshiro-cho Mizuho-ku Nagoya, 467 Japan This product complies with FDA radiation performance standards, 21 CFR chapter 1 subchapter J.</p>
--

- ☛ **Caution:** Use of controls, adjustments or performance of procedures other than those specified in this manual may result in hazardous radiation exposure.

DECLARATION OF CONFORMITY (EUROPE)

We, Brother International Europe Ltd.,
Brother House 1 tame Street, Guide Bridge,
Audenshaw, Manchester M34 5JE, UK.

declare that this product is in conformity with the following normative documents:

Safety: EN 60950, EN 60825
EMC: EN 55022 Class B, EN 50082-1

following the provisions of the Low Voltage Directive 73/23/EEC and the Electromagnetic Compatibility Directive 89/336/EEC (as amended by 91/263/EEC and 92/31/EEC).

Manufacture at the following facilities is carried out under a Quality System which is registered by BSI Quality Assurance and JQA Quality Assurance.

Brother Industries, Ltd., Kariya Plant
1-5, Kitajizoyama, Noda-cho, Kariya-shi,
Aichi-ken 448, Japan.
BSI Certificate of Registration No. FM27391
JQA Certificate of Registration No. 0340

Issued by:

Brother International Europe Ltd.
European Development and Technical Services Division

IEC 825 (220-240 V model only)

This printer is a Class 1 laser product as defined in IEC 825 specifications. The label shown below is attached in countries where required.

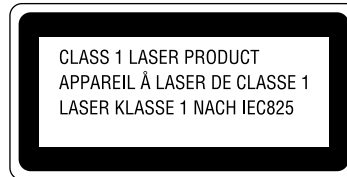

This printer has a Class 3B Laser Diode which emits invisible laser radiation in the Scanner Unit. The Scanner Unit should not be opened under any circumstances.

☞ **Caution:** Use of controls, adjustments or performance of procedures other than those specified in this manual may result in hazardous radiation exposure.

The following caution label is attached on the cover of the scanner unit.

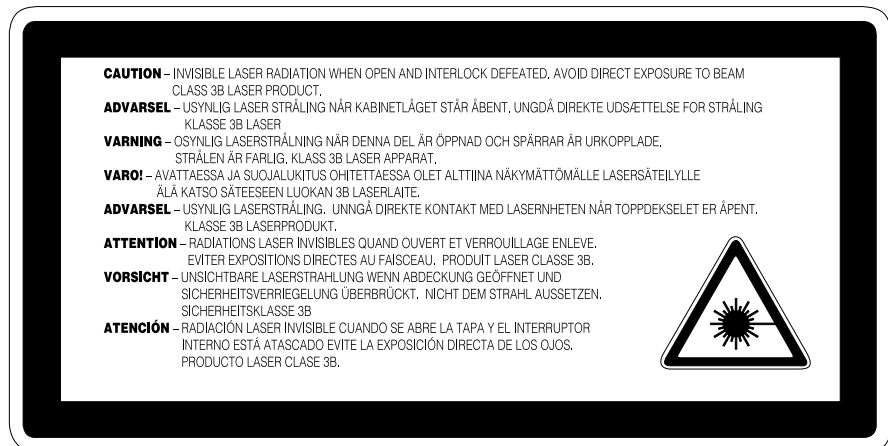

For Finland and Sweden

LUOKAN 1 LASERLAITE KLASS 1 LASER APPARAT

☞ **Varoitus!** Laitteen käyttäminen muulla kuin tässä käyttöohjeessa mainitulla tavalla saattaa altistaa käyttäjän turvallisuusluokan 1 ylittävälle näkymättömälle lasersäteilylle.

Varning – Om apparaten används på annat sätt än i denna Bruksanvisning specificerats, kan användaren utsättas för osynlig laserstrålning, som överskrider gränsen för laserklass 1.

For Your Safety

To ensure safe operation the three-pin plug supplied must be inserted only into a standard three-pin power point which is effectively grounded through the normal household wiring.

Extension cords used with the equipment must be three-conductor and be correctly wired to provide connection to ground. Incorrectly wired extension cords are a major cause of fatalities.

The fact that the equipment operates satisfactorily does not imply that the power is grounded and that the installation is completely safe. For your safety, if in any doubt about the effective grounding of the power, consult a qualified electrician.

Wiring Information (For U.K. only)

Important

If the mains plug supplied with this printer is not suitable for your socket outlet, remove the plug from the mains cord and fit an appropriate three pin plug. If the replacement plug is intended to take a fuse then fit the same rating fuse as the original.

If a moulded plug is severed from the mains cord then it should be destroyed because a plug with cut wires is dangerous if engaged in a live socket outlet. Do not leave it where a child might find it!

In the event of replacing the plug fuse, fit a fuse approved by ASTA to BS1362 with the same rating as the original fuse.

Always replace the fuse cover. Never use a plug with the cover omitted.

WARNING - THIS PRINTER MUST BE EARTHED

The wires in the mains cord are coloured in accordance with the following code :

GREEN AND YELLOW	: EARTH
BLUE	: NEUTRAL
BROWN	: LIVE

The colours of the wires in the mains lead of this printer may not correspond with the coloured markings identifying the terminals in your plug.

USER'S GUIDE

If you need to fit a different plug, proceed as follows.

Remove a length of the cord outer sheath, taking care not to damage the coloured insulation of the wires inside.

Cut each of the three wires to the appropriate length. If the construction of the plug permits, leave the green and yellow wire longer than the others so that, in the event that the cord is pulled out of the plug, the green and yellow wire will be the last to disconnect.

Remove a short section of the coloured insulation to expose the wires.

The wire which is coloured green and yellow must be connected to the terminal in the plug which is marked with the letter "E" or by the safety earth symbol \perp , or coloured green or green and yellow.

The wire which is coloured blue must be connected to the terminal which is marked with the letter "N" or coloured black or blue.

The wire which is coloured brown must be connected to the terminal which is marked with the letter "L" or coloured red or brown.

The outer sheath of the cord must be secured inside the plug. The coloured wires should not hang out of the plug.

CHAPTER 1

GENERAL

ABOUT THIS MANUAL

This manual acts as your guide to the setup and operation of your printer and covers the following topics:

CHAPTER 1 GENERAL provides an overview of the printer. Read this chapter first to get familiar with the printer.

CHAPTER 2 GETTING STARTED gives you general information about this printer. Be sure to read this chapter before you use the printer.

CHAPTER 3 BEFORE WORKING WITH THE PRINTER gives you important information on the printer setup to work with your computer and software. Be sure to read this chapter before you work with the printer.

CHAPTER 4 CONTROL PANEL details the functions of the panel switches and lamps. (Disk)

CHAPTER 5 OPTIONS describes the optional accessories for this printer. (Disk)

CHAPTER 6 MAINTENANCE provides guidance on how to maintain your printer. (Disk)

CHAPTER 7 TROUBLESHOOTING helps you troubleshoot the printer in case of problems.

APPENDICES contain detailed technical information on the printer as well as the character sets and a quick reference guide to the printer control commands. (Disk)

INDEX provides an alphabetical list of the contents of this manual and the floppy disk supplied with the printer.

 **Notes**

When you read this user's guide, note the following:

- Chapters 4, 5, 6 and the Appendices of this User's Guide are on the floppy disk provided with this printer. Read ABOUT CHAPTERS ON THE FLOPPY DISK (See page 1-3) carefully before you print out the additional chapters included on the floppy disk.
- This user's guide contains instructions or steps to teach you various operations of the printer. Remember that the instructions start with the factory settings, particularly in Chapter 2 and Chapter 3. If you change the settings, particularly the emulation mode, the display messages change accordingly.
- The paper size has been factory set to letter or A4, depending upon the final destination of the printer. Some display messages appear differently in accordance with this setting.

ABOUT CHAPTERS ON THE FLOPPY DISK

- The floppy disk provided with this printer contains Chapters 4, 5, 6, and the Appendices of this User's Guide. Follow the steps below to install and print out the sections you need to see.

1. Set up your printer referring to CHAPTER 2 GETTING STARTED.
2. Start your computer and MS-DOS® or Microsoft®-Windows® version 3.1.
3. Insert the printer User's Guide floppy disk into the floppy disk drive A of your computer. It is assumed that A: is your floppy disk drive in this description.
4. Install the Disk Manual into your computer.
(for DOS user)
Type A:\INSTALL and press ENTER key.
Follow the messages on the screen.

(for Windows user)

Choose the RUN command from the FILE menu in the Program Manager.

Type A:\SETUP and press the ENTER key.

- Once you installed the Disk Manual into your computer, follow the steps below to print out the sections you need to see.

Print chapters on the Disk Manual.

(for DOS user)

Type HL960 and press ENTER key. You do not need to choose disk drive nor directory.

Follow the messages on the screen.

(for Windows user)

Double-click the HL960 Series group icon (sign on the screen) and then the Disk Manual icon.

Follow the messages on the screen.

Notes

- You will need a minimum of 6 MB free area on your hard disk drive in order to print any sections of the User's Guide.
- Use A4 or letter size paper for printing.

ABOUT THIS PRINTER

Features

This printer has the following standard features. When you need more information on how to use a particular feature, turn to the page indicated at the end of the paragraph.

High Speed and Quiet Laser Printing

This printer uses electrophotography technology by laser beam scanning so that it can print at a speed of 12 pages per minute. The controller utilizes a high speed 32-bit RISC microprocessor and special hardware chips. The quiet printing will not bother you working in your office or at home: max. 49 dB A (printing)/40 dB A (stand-by).

Resolution of 600 DPI

This printer uses a print engine with a resolution of 600 dots per inch (dpi). As compared with a 300-dpi engine, the quality of the output is far superior. See page 4-26. By utilizing the 300-dpi mode, the printer can print 300-dpi data, if necessary.

Maintenance-Free Toner Cartridge

A toner cartridge can print up to 6,000 single-sided pages. The one piece, easy-to-replace toner cartridge does not require difficult maintenance. Just install it. See 2-7.

Universal Paper Cassette and Manual Loading

This printer loads paper automatically from the paper cassette. Since the paper cassette is a universal type, a number of different sizes of paper can be used. Even envelopes can be loaded from the multi-purpose tray and the upper paper cassette. In addition, the multi-purpose tray allows you to load paper sheet by sheet. See 3-15 for auto loading and 3-16 for manual loading.

Two Interfaces

This printer has a high speed bi-directional parallel interface and an RS-232C serial interface.

If your application software supports the bi-directional parallel interface, you can monitor the printer status. It is fully compatible with the industry-standard bi-directional parallel interface. See page 2-17.

The RS-232C serial interface is an industry standard so that you can connect it to any computer using a standard serial cable. See page 2-17.

Automatic Interface Selection

This printer can automatically select the bi-directional parallel or RS-232C serial, interface depending on the interface port through which it receives data. With this feature, the printer can be connected to more than one computer. See page 3-5.

Four Emulation Modes

This printer can emulate the Hewlett-Packard® laser printer-LaserJet 4 (PCL® 5^e) printer, the industry-standard HP-GL™ plotter as well as EPSON® FX-850™, and IBM® Proprinter XL® printers. You can print with all application programs that support one of these printers. See page 3-1.

Automatic Emulation Selection

This printer can automatically select the printer emulation mode depending on the print commands it receives from the computer software. With this feature, many users can share the printer on a network. See page 3-3.

Data Compression Technology

This printer can internally compress the received graphics and font data in its memory so that it can print larger graphics and more fonts without additional memory.

Memory Expansion

This printer has 2-Mbyte of RAM as standard. It can be expanded up to 26 Mbytes. When you select duplex mode with an optional duplex unit installed, the memory should be expanded by 8Mbytes (10Mbytes in total) or more to enjoy 600-dpi duplex printing. See pages 4-26 and 5-6.

19 Scalable and 10 Bitmapped Fonts

This printer has the following scalable fonts and bitmapped fonts. The fonts that can be used vary according to the current emulation mode.

- HP LaserJet 4, EPSON FX-850, and IBM Proprinter XL Modes See printed Appendix after Chapter 7.

Scalable Fonts:

Intellifont Compatible Fonts:

- Brougham, Oblique, Bold, BoldOblique
- Cleveland Condensed
- Connecticut
- Guatemala Antique, Italic, Bold, BoldItalic
- Maryland
- PC Tennessee Roman, Italic, Bold, BoldItalic
- Utah, Oblique, Bold, BoldOblique

Bitmapped Fonts (Portrait and Landscape):

- LetterGothic16.66 Medium, Italic, Bold, BoldItalic
- OCR-B

High Speed Printing with Microsoft Windows 3.1

Since TrueType compatible fonts are resident in this printer, the printer can print them with Microsoft Windows version 3.1 and higher at a high speed without downloading them. Because the printer has a TrueType Font rasterizer, it can rasterize fonts at a high speed.

Bar Code Print

This printer can print the following 11 types of bar codes:

- Code 39
- Interleaved 2 of 5
- EAN-8
- EAN-13
- UPC-A
- EAN-128
- UPC-E
- Codabar
- US-PostNet
- ISBN
- Code 128

CCITT G3/G4

Since this printer supports the CCITT G3/G4 format in addition to HP-compatible formats, it can quickly receive and print data compressed in this format.

Lock Panel

If the panel switch settings have been changed, the printer may not work as you expect. You can lock your settings to prevent changes from being made. See page 4-37.

Power Save Mode

This printer has a power saving mode. As laser printers consume power to keep the fixing assembly at a high temperature, this feature can save electricity when the printer is on but not being used. The factory setting of the Power Save mode is ON that complies with EPA Energy Star new specification. Compared with conventional laser printers, this printer consumes less power even when the power saving mode is turned off. See page 4-64.

Reprint Function

You can reprint the last page printed with a touch of a panel switch which allows reprinting without sending the data again from the computer. See page 4-56.

Flash Memory Card and HDD Card

You can store fonts, macros, logos, and other print data in a commercial PCMCIA-compatible flash memory card or HDD card that is installed in the upper card slot of this printer. See pages 4-29 and 5-2.

Saving User Settings

You can operate the printer differently from other users with your own panel switch settings. Two sets of user settings can be stored. See page 4-42.

Options

The following options are available for this printer:

Lower Tray Unit

A lower tray unit expands the paper source capacity. You can load extra paper and switch between the upper and lower paper sources automatically. See page 5-1.

Duplex Unit

A duplex unit enables you to print on both sides of the paper. See page 5-10.

Technical Reference Manual

The technical reference manual contains detailed information about the printer control commands. For programming with the printer, see this manual which is available from your Brother dealer.

The following commercial products can be installed into this printer:

Font Cartridges

Commercial font cartridges containing additional scalable fonts or bitmapped fonts. See page 5-2.

Flash Memory Card and HDD Card

A commercial flash memory card or a HDD card can be installed. You can store fonts, macros, logos, and other print data in a commercial PCMCIA-compatible flash memory card or HDD card. See pages 4-29 and 5-2.

RAM Expansion

Installing commercial memory modules expands the memory capacity up to 26 Mbytes. See pages 5-6.

USER'S GUIDE

CHAPTER 2

GETTING STARTED

BEFORE USING THE PRINTER

Checking the Components

Printer Carton

When you unpack the printer, check to see that you have all of the following parts.

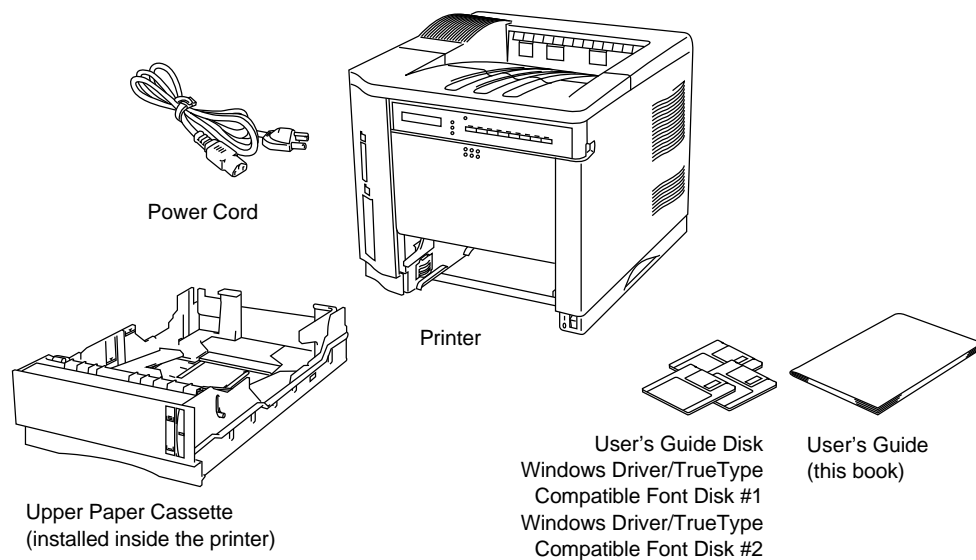

Fig. 2-1 Components in the Printer Carton

Note

An interface cable is not a standard accessory. Please purchase an appropriate cable according to the interface you intend to use. The power cord may differ slightly from this figure depending on the country where you purchased the printer.

Toner Cartridge

The toner cartridge is inside the toner cartridge carton.

⚠ Caution

The toner cartridge is packed inside a bag. Do not open it now. Open it immediately before you install the toner cartridge. The toner cartridge must not be exposed to light for a long time.

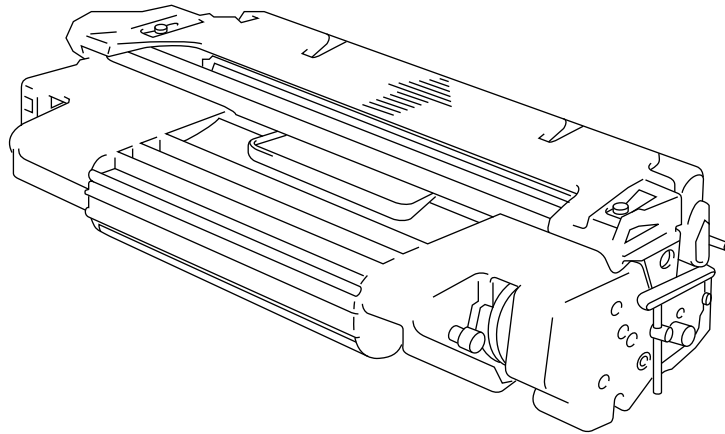

Fig. 2-2 Toner Cartridge

General View

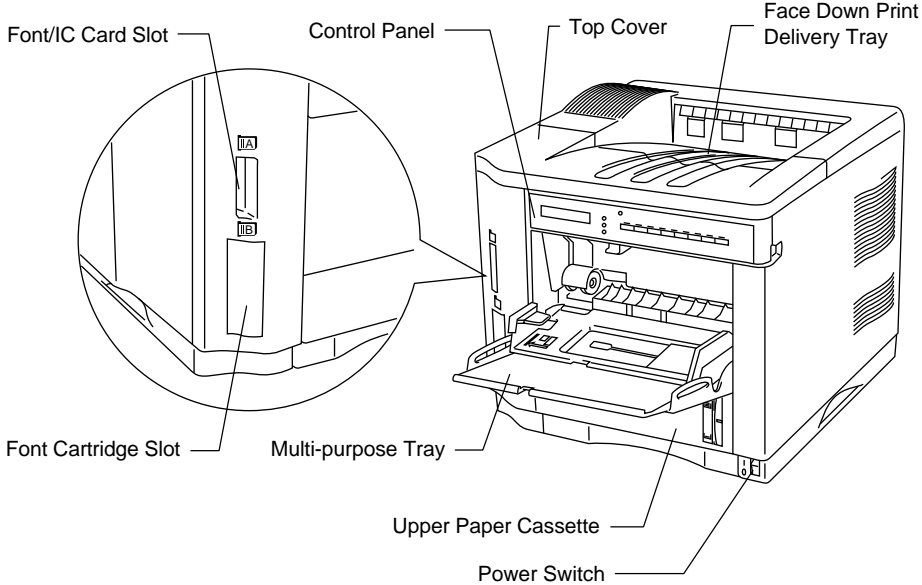

Fig. 2-3 Front View

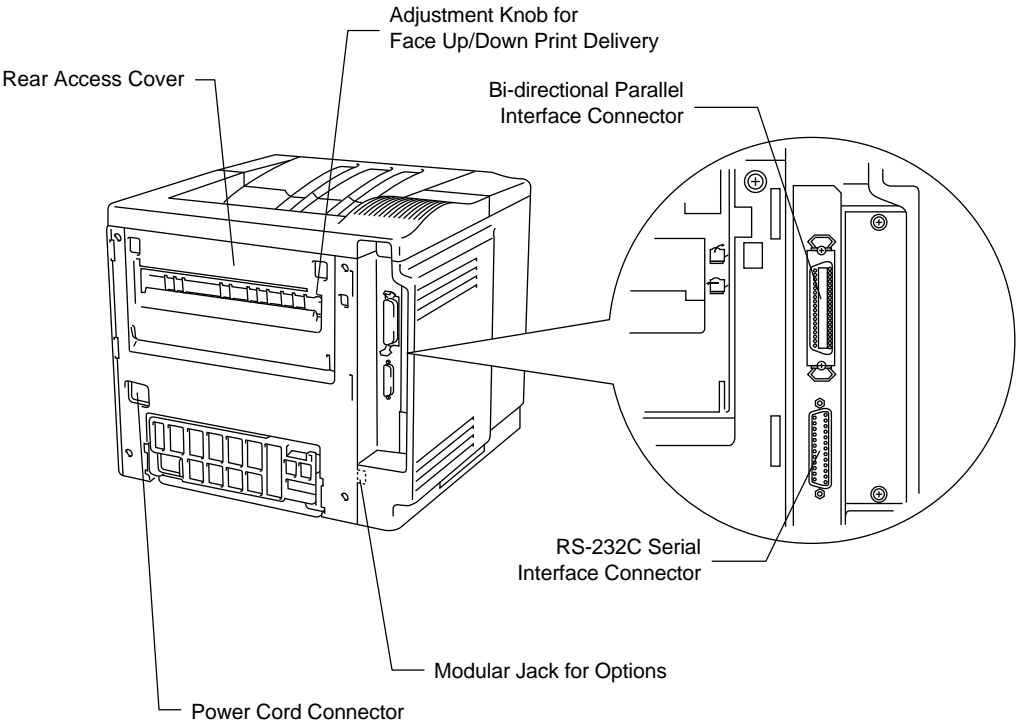

Fig. 2-4 Rear View

Operating and Storage Environment

Please take note of the following before using the printer.

Power Supply

Use the printer within the specified power range.

AC power: $\pm 10\%$ of the rated power voltage

Frequency: 50 Hz (220-240 V) or 60 Hz (110-120 V)

The power cord, including extensions, should not exceed 5 meters (16.5 feet).

Do not share the same power circuit with other high-power appliances, particularly an air conditioner, copier, shredder, etc. If it is unavoidable that you must use the printer with these appliances, we recommend you use a voltage transformer or a high-frequency noise filter.

Use a voltage regulator if the power source is not stable.

Environment

Use the printer only within the following ranges of temperature and humidity.

Ambient temperature: 10°C to 32.5°C (50°F to 90.5°F)

Ambient humidity: 20% to 80% (without condensation)

Do not block the air exit on top of the printer. Do not place objects on top of the printer, especially on the air exit.

Ventilate the room where you use the printer.

Do not place the printer where it is exposed to direct sunlight. Use a blind or a heavy curtain to protect the printer from direct sunlight if the printer is unavoidably set up near a window.

Do not install the printer near devices that contain magnets or generate magnetic fields.

Do not subject the printer to strong physical shocks or vibrations. Do not expose the printer to open flames or salty or corrosive gasses.

Place the printer on a flat, horizontal surface.

Keep the printer clean. Do not install the printer in a dusty place. Do not install the printer near an air conditioner.

SETTING UP THE PRINTER

Opening and Closing the Printer

To install the toner cartridge or to access the paper path, you need to open the top cover of the printer. Remember the following steps to open and close the printer.

- To open the printer, hold both sides of the top cover and raise it upwards until it latches.

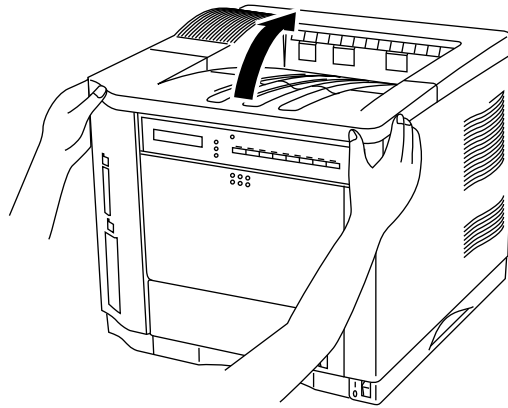

Fig. 2-5 Opening the Top Cover

- To close the printer, lower the top cover and push both sides gently until it latches.

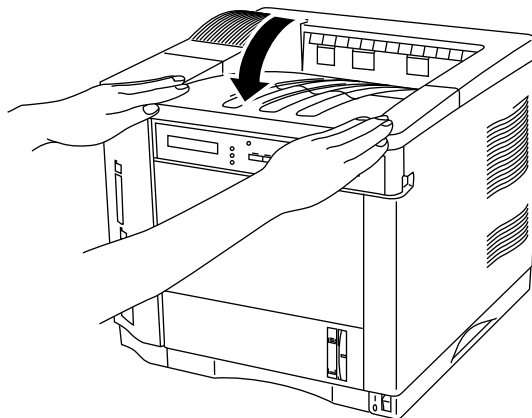

Fig. 2-6 Closing the Top Cover

Removing the Protective Parts

After checking that you have all of the correct parts, temporarily place the printer where you can easily reach all sides. Remove the protective parts that secure the printer against damage during transportation, as shown below:

Note

Keep all packing materials for transporting or storing the printer later.

1. Open the top cover and the upper paper cassette.
2. Remove the protective parts from inside the printer and the cassette.
3. Remove both spacers from the fixing roller.

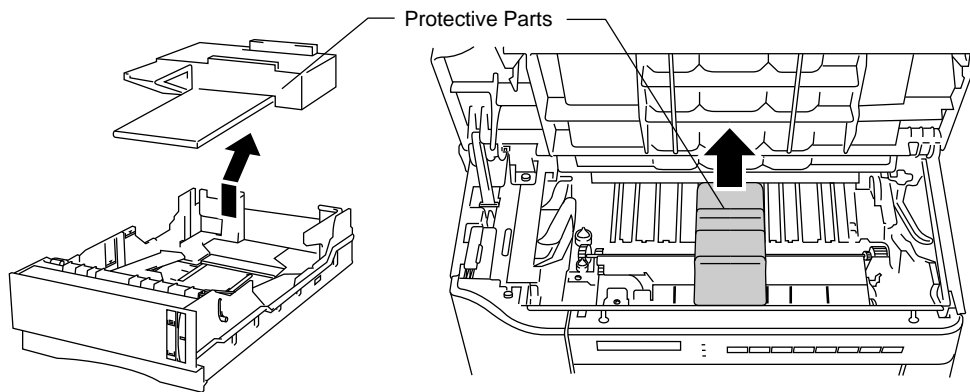

Fig. 2-7 Removing the Protective Parts

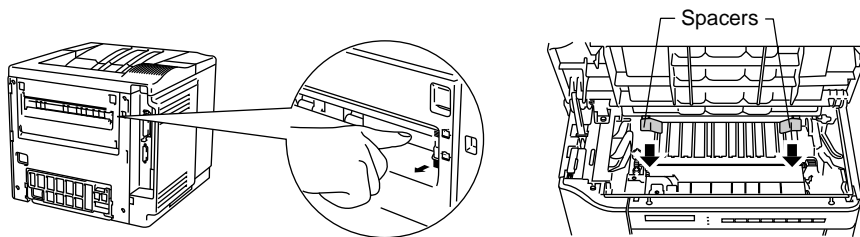

Fig. 2-7 Removing the Protective Parts

Fig. 2-8 Removing the Spacers

Installing the Toner Cartridge

This printer uses a toner cartridge to print. You have one toner cartridge as standard. A new cartridge contains enough toner to print approximately 6,000 A4 or letter-size single-sided pages at about 5% coverage (if the print density is set at level 8).

If you turn on the printer without the toner cartridge installed, the display shows the following operator call message to prompt you to install the toner cartridge.

14 NO CARTRIDGE

To install the toner cartridge, follow these steps:

1. Open the top cover of the printer.
2. Open the bag to unpack the toner cartridge.

⚠ Caution

- Do not expose the toner cartridge to direct light.
- Do not stand the toner cartridge on its end or turn it up-side down.
- Do not touch the shaded parts shown below.
- Do not open the drum shutter otherwise the toner or drum is adversely affected and might cause serious damage when printing.

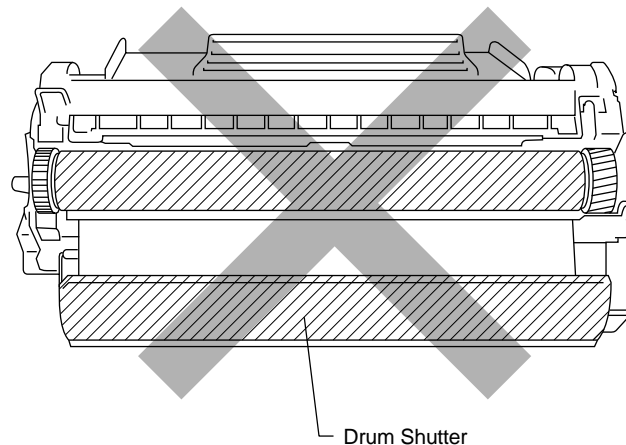

Fig. 2-9 Don'ts When Handling the Toner Cartridge

3. Hold the toner cartridge with both hands. Rock it gently several times at a 45° angle. This distributes the toner evenly inside the cartridge.

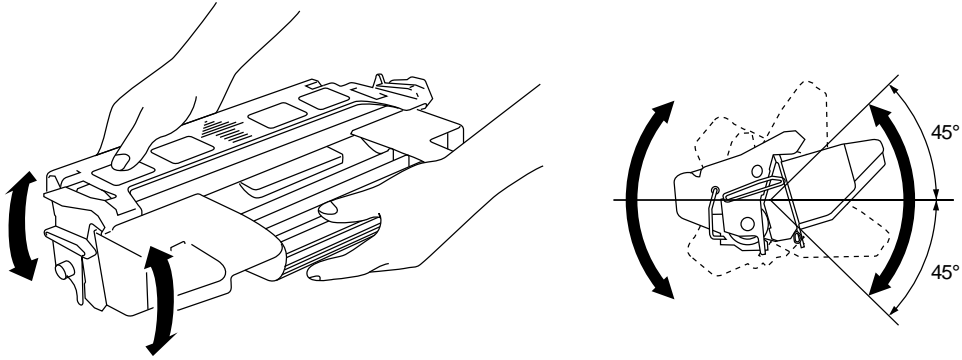

Fig. 2-10 Rocking the Toner Cartridge

4. Bend the tab up and down several times until it is detached from the toner cartridge.

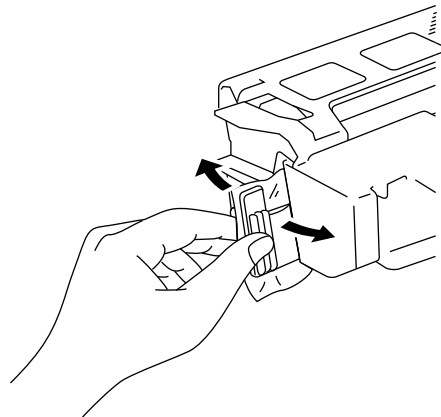

Fig. 2-11 Detaching the Tab

5. Hold the tab firmly and pull it out until the sealing tape comes out all the way.

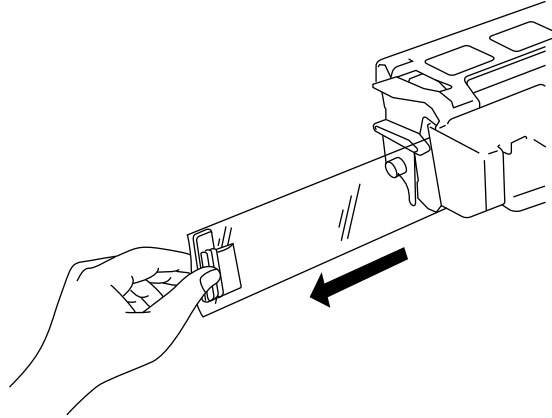

Fig. 2-12 Pulling Out the Sealing Tape

⚠ Caution

If the tab breaks from the sealing tape, hold and pull out the tape. If your hands or clothes get dirty with toner, wipe or wash it off immediately with cold water.

6. Insert the toner cartridge in the direction of the arrows engraved on the cartridge into the side guides until it stops securely in the cartridge holder inside the printer.

🔧 Note

Push both sides of the toner cartridge gently until the cartridge is seated in its place.

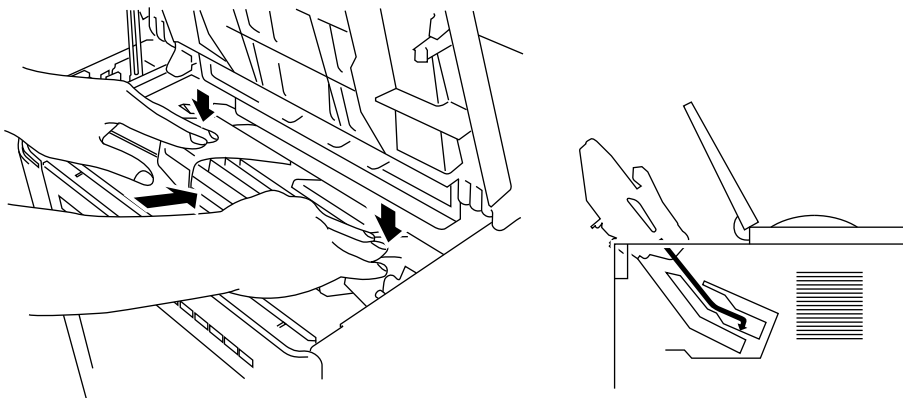

Fig. 2-13 Inserting the Toner Cartridge

7. Close the top cover of the printer.

When the cartridge has almost run out of toner, the display shows the following operator call message to prompt you to replace the toner cartridge.

16 TONER EMPTY

Although you can print several pages after the toner empty message appears, be sure to replace the toner cartridge with a new one before it becomes completely empty.

 Note

You can select the printer's operation when the "Toner Empty" message is displayed with the MODE switch. The printer continues or stops printing. For further information, see "Toner Low" in Chapter 4.

For toner cartridge replacement, see "Toner Cartridge" in Chapter 6.

Loading Paper in the Paper Cassette

The printer usually loads paper from the installed multi-purpose tray, upper cassette or optional lower paper cassette.

Note

The lower tray unit is an option for this printer. This section refers to the upper paper cassette. For information about the lower paper cassette, see “LOWER TRAY UNIT” in Chapter 5.

Since the paper cassette is a universal type, you can set letter, A4, legal, ISO B5, executive, A5, ISO B6, or A6 size cut sheet paper or COM10, Monarch, C5, DL, or ISO B5 size envelopes in the paper cassette.

The paper sources have the following limitation. For more information about paper, see “PRINT MEDIA” in Chapter 3.

paper source	available size	available type and capacity
the multi-purpose tray (MP)	cut sheet : letter, legal, A4, ISO B5, Executive, A5, ISO B6 and A6 envelope: COM 10, Monarch, C5, DL and ISO B5 other size: wide 90-216mm (3.5"-8.5") long 148-356mm (5.8"-14")	plain paper : 150 envelope : 15 OHP film : 100 label stock : 100 other type : weight = 60 to 135 g/m ² (16 to 36 lbs)
the upper paper cassette (T1)	cut sheet : letter, legal, A4, ISO B5, Executive, A5, ISO B6 and A6 envelope : COM 10, Monarch, C5, DL and ISO B5	plain paper : 500 weight = 60 to 105 g/m ² (16 to 28 lbs) envelope : 40
the optional lower paper cassette (T2)	cut sheet : letter, legal, A4, Executive	plain paper : 500 weight = 60 to 90 g/m ² (16 to 24 lbs)
all sources for duplex printing (DX)	cut sheet : letter, legal, A4, ISO B5(except T2) and Executive	* The capacity of T1 is reduced from the above specified capacities with the duplex unit installed.

Follow these steps to set paper and install the paper cassette:

Note

Be sure to select the same paper size as the paper to be used from your application software, or correct printing cannot be obtained.

If your application software does not support paper size selection on its print menu, you can change the paper size with the MODE switch in the FORMAT MODE. For paper size change, see "MODE Switch" in Chapter 4.

The paper size has been factory set to letter or A4, depending upon the final destination of the printer.

- 110/120V model: Letter size paper set.
- 220/240V model: A4 size paper set.

Load paper into the paper cassette as follows:

1. Pull the paper cassette out of the printer.

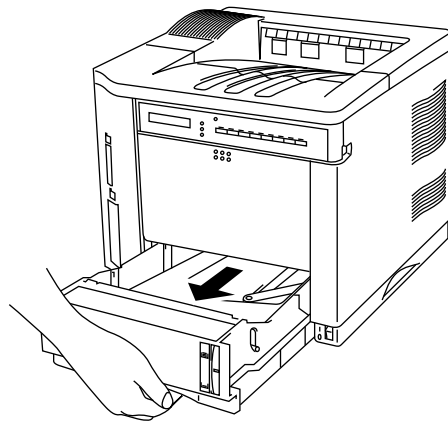

Fig. 2-14 Removing the Paper Cassette

2. Switch the adjustment lever on the back of the paper cassette according to the paper size shown below.

- I. Backwards : letter, legal, A4, ISO B5, Executive and A5
- II. Forwards : ISO B6, A6, COM10, Monarch, C5 and DL

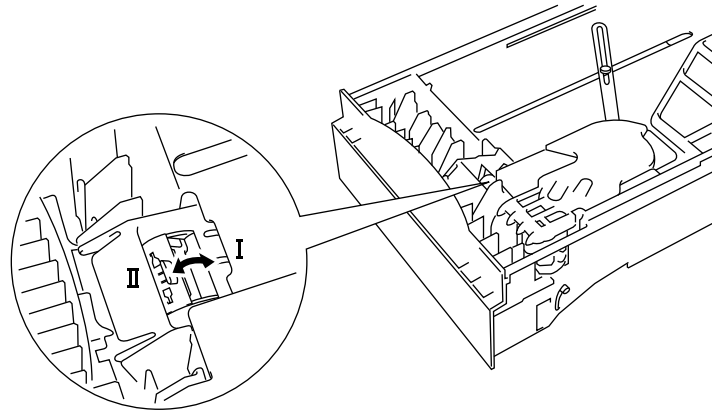

Fig. 2-15 Switching the Adjustment lever by Paper Size

3. Set a side paper stop at right front corner inside the paper cassette by the paper size to be used so that 2 projectors of the side paper stop are inserted into the guide holes on the base of the paper cassette.

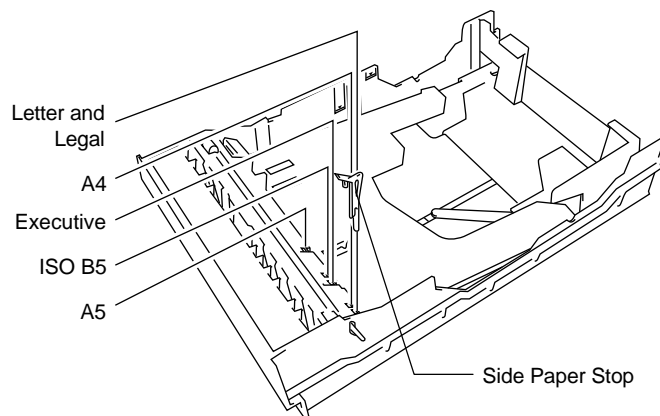

Fig. 2-16 Setting the Side Paper Stop

4. Slightly lift the edge of the sliding guides and move them separately so as to match the size of paper to be used. Match the paper length first and then the paper width when setting for larger size paper. Match the paper width first and then the paper length when setting for smaller size paper.

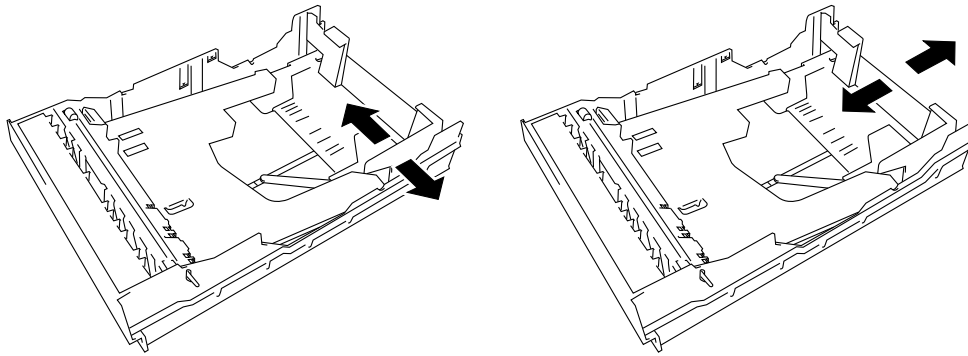

Fig. 2-17 Adjusting the Paper Cassette Sizes

5. Load paper into the paper cassette as shown below.

⚠ Caution

Do not load more than 500 sheets of paper (80 g/m² or 20 lbs.) in the cassette, or paper jams may occur. Paper (80 g/m² or 20 lbs.) should be loaded up to the arrow head marked on the sliding guide.

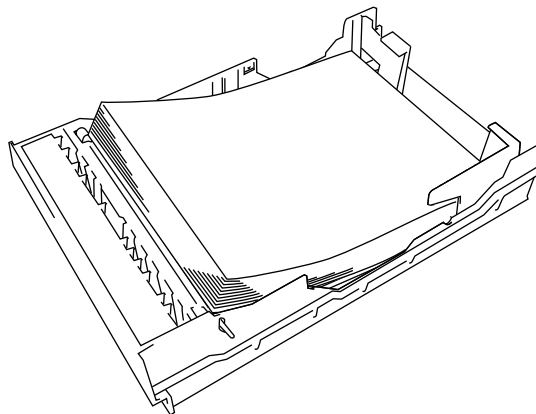

Fig. 2-18 Loading Paper into the Cassette

6. Install the paper cassette into the printer.

🔧 Note

You can check the remaining paper with the paper indicator located on the front right of the paper cassette.

1. Open the multi-purpose tray by pressing the front door of the tray lightly and lowering it gently.

Note

Pull out the extension tray of the multi-purpose tray for long paper if it is necessary.

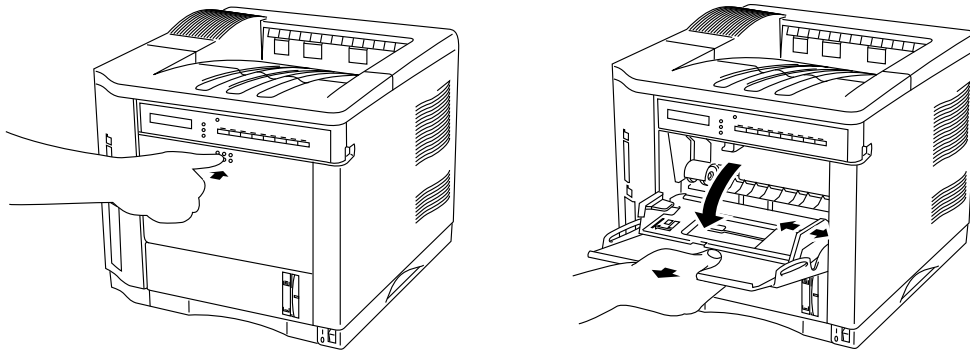

Fig. 2-19 Opening the Multi-purpose Tray and Pulling Out the Extension Tray

2. Lift up and slide the paper width guide to the far right side.
3. Place a stack of paper or envelopes on the tray until it is securely seated.

Notes

When you place paper on the multi-purpose tray, note the following:

- The print surface must be face up.
- The leading edge must be placed inside first and lightly against the printer.
- The left side must be aligned with the left guide.
- The top of the paper stack must be under the holders on both sides of the tray. The maximum thickness is 16.5 mm or 0.65 inches.

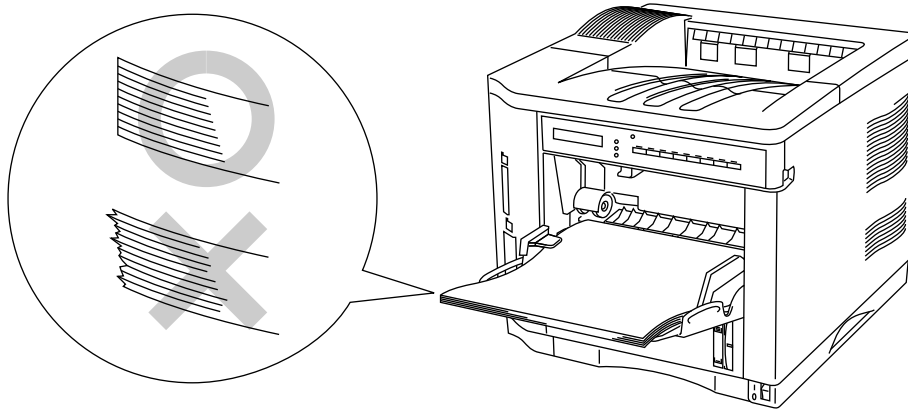

Fig. 2-20 Placing Paper on the Multi-purpose Tray

4. Lift up and slide the paper width guide to match the paper width, so that it lightly touches the right side of the paper stack.

⚠ Caution

- Make sure that the neatly stacked paper is correctly seated on the multi-purpose tray, otherwise paper may not be fed correctly, resulting in a skewed printout or a paper jam.
- When printing, the inside tray automatically rises to feed paper into the printer.

Connecting the Printer to Your Computer

This printer has a bi-directional parallel interface and an RS-232C serial interface. They allow the printer to communicate with IBM/PC® or compatible computers. Before connecting the printer and computer, you need to purchase or make a connecting cable specifically for the interface to be used. See “INTERFACE SPECIFICATIONS” in Appendix.

Since the automatic interface selection mode has been factory set, simply connect the interface cable to the printer. In some cases, you need to turn off the high-speed and bi-directional parallel communications with the MODE switch. For further information, see “MODE Switch” in Chapter 4.

When you use the serial interface, you need to have the same communications settings on both the printer and computer. Since the automatic interface selection mode has been factory set with certain factory settings (baud rate = 9600, code type = 8 bits, parity = none, stop bit = 1, Xon/Xoff = ON, DTR (ER) = ON, and Robust Xon = ON), you may simply connect the interface cable if these are the same as the settings on your computer. When necessary, set the communications parameters with the MODE switch on the printer. For further information, see “MODE Switch” in Chapter 4. For the settings on the computer, see the manual of the computer or software you use.

Connect the printer to your computer as follows:

1. Make sure that both the computer and the printer are turned off.

⚠ Caution

Always turn off the printer and computer when connecting and disconnecting the cable.

2. Connect one end of the interface cable to the interface connector located on the back of the printer.

3. Secure the connection with wire clips or screws on the printer.

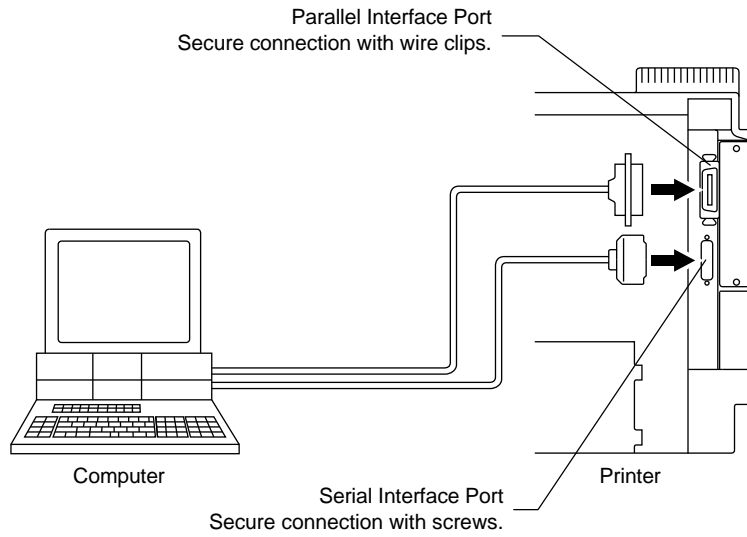

Fig. 2-21 Connecting the Printer and Computer

4. Connect the other end of the interface cable to the interface connector on your computer. Be sure to secure the connection on the computer, also.

Turning the Printer On and Off

Plugging in the Power Cord

Plug in the power cord as follows:

1. Make sure that the POWER switch is OFF "O": the switch is on the front right hand side of the printer.
2. Attach the power cord to the printer and plug it into an appropriate AC outlet.

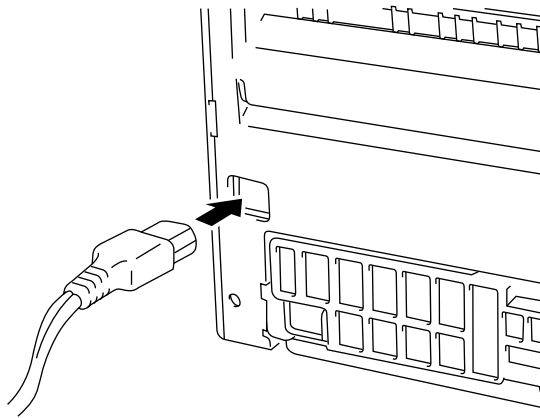

Fig. 2-22 Plugging in the Power Cord

⚠ Caution

- Check the AC voltage. This printer should be operated at the specified voltage and frequency.
 - USA and Canada: AC 110 to 120 V, 60 Hz
 - Europe and Australia: AC 220 to 240 V, 50 Hz
- Since this printer must be electrically grounded, the power cord should be connected to a grounded AC outlet.
- The total length of the power cord, including extension cords, should not exceed 5 meters (16.4 feet). Use of a longer power cord may result in reduced voltage or malfunctions.
- Do not unplug the power cord to turn off the printer.
- The printer should be installed near a power outlet which is easily accessible.

Pressing the POWER Switch

The POWER switch is on the front right hand side of the printer. Pressing the ON side “|” supplies power to the printer, which then performs a self test and warm up. Pressing the OFF side “O” turns the power off.

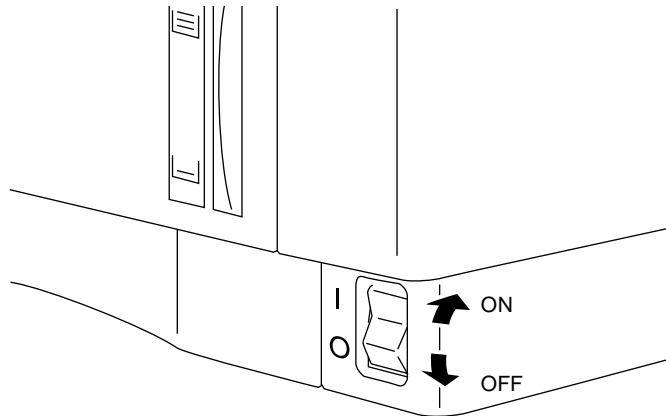

Fig. 2-23 Pressing the POWER Switch

⚠ Caution

Always wait at least 2 seconds after turning off the power before turning it back on.
Do not turn the power off while the printer is printing, as this may cause a paper jam and adversely affect the printer.

The printer performs a self-diagnosis at start-up to check its hardware and software. If the printer should find any problems, the display will show the corresponding message. See “TROUBLESHOOTING” in Chapter 7.

04 SELF TEST

The display shows several messages quickly at start-up. If the printer detects no errors, it automatically goes on-line and the message changes to show the current printer status and settings.

LJ READY 001P T1

LJ : The auto emulation selection is set and currently the HP LaserJet 4 emulation mode is selected.
READY : The printer is ready to print.
001 : The number of copies to print is set to 1.
P : Portrait print is selected.
T1 : Paper is fed from Tray1.

Printing the Test Patterns or Lists

You can check print quality and print a list of available fonts before you actually start working with the printer. To do so, follow these steps:

1. Make sure that you have already set the toner cartridge and loaded paper into the cassette or the multi-purpose tray.
2. Turn on the printer. Wait until the display shows the message as follows.

LJ READY 001P T1

or

LJ READY 001P MP

3. Press the SEL switch to set the printer off-line.

The ON LINE lamp goes off.

4. Hold down the SHIFT switch and press the TEST switch.
5. Press the ▲ or ▼ switch to scroll through the display until the desired message appears. To print your selection, press the SET switch.

Choose from one of the following selections :

To print out the test pattern,

TEST PRINT

To print out the list of printer settings,

PRINT CONFIG

To print out the list of internal or resident fonts,

PRINT FONTS I

To print out the list of optional cartridge/card fonts,

```
PRINT FONTS C
```

To print out the list of permanent download fonts,

```
PRINT FONTS P
```

To exit from the test mode,

```
exit
```

✍ Notes

The messages “PRINT FONTS C” or “PRINT FONTS P” appear only when an optional font cartridge/card is installed in the font slot or the permanent download fonts are stored in printer memory respectively.

- If the optional font cartridge/card is installed, you can print out a list of optional fonts. Since the list shows the ID numbers specific to each optional font, it helps you to select them with the FONT switch. For further information, see “FONT Switch” in Chapter 4 and “FONT CARTRIDGE/CARD, FLASH MEMORY/HDD CARD” in Chapter 5.
- If user-defined characters are already downloaded into the printer memory as permanent download fonts, you can print out a list of them. For further information, see “FONT Switch” in Chapter 4.

6. Press the SET switch.

The printer starts printing the selected test pattern or list. When the printer finishes printing, it automatically exits to the off-line state.

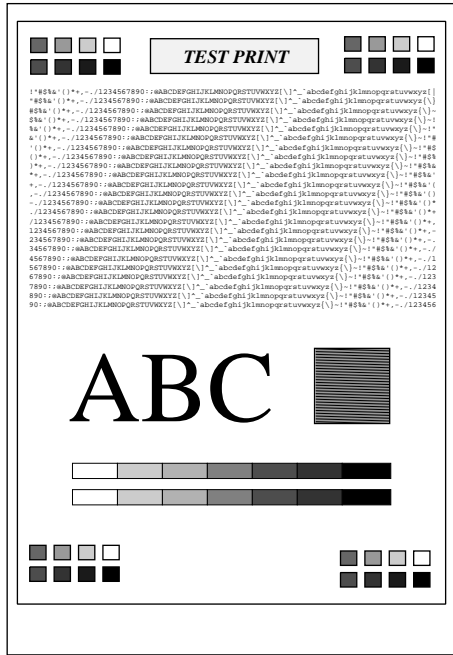

TEST PRINT

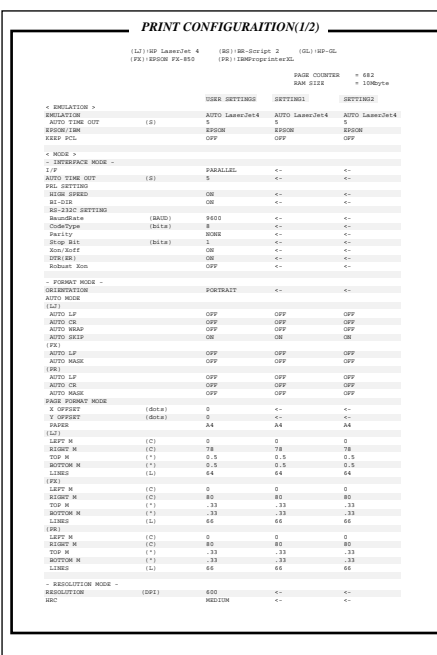

PRINT CONFIG

PORTRAIT LIST

NUMBER	SIGNAL SET	INTERNAL FONT
1000	EPSON 8... P: Scaleable Upright(0) Medium(0) DUTRINE Reg (410) ESC: ESC@w0a04100	ABCDefgh123?!#\$%&'()*<>/012
1001	EPSON 8... P: Scaleable Upright(0) Bold(1) DUTRINE Bd (410) ESC: ESC@w0a04100	ABCDefgh123?!#\$%&'()*<>/01
1002	EPSON 8... P: Scaleable Italic(1) Medium(0) DUTRINE It (410) ESC: ESC@w0a04100	ABCDefgh123?!#\$%&'()*<>/012
1003	EPSON 8... P: Scaleable Italic(1) Bold(1) DUTRINE Bdt (410) ESC: ESC@w0a04100	ABCDefgh123?!#\$%&'()*<>/012
1004	EPSON 8... P: Scaleable Upright(0) Medium(0) OELAROMA Reg (411) ESC: ESC@w0a041100	ABCDefgh123?!#\$%&'()*<>/0
1005	EPSON 8... P: Scaleable Upright(0) Bold(1) OELAROMA Bd (411) ESC: ESC@w0a041100	ABCDefgh123?!#\$%&'()*<>/0
1006	EPSON 8... P: Scaleable Italic(1) Medium(0) OELAROMA It (411) ESC: ESC@w0a041100	ABCDefgh123?!#\$%&'()*<>/0
1007	EPSON 8... P: Scaleable Italic(1) Bold(1) OELAROMA Bdt (411) ESC: ESC@w0a041100	ABCDefgh123?!#\$%&'()*<>/0
1008	EPSON 8... P: Scaleable Italic(1) Medium(0) CONNECT CUT (414) ESC: ESC@w0a041140	ABCDefgh123?!#\$%&'()*<>/0123456
1009	EPSON 8... P: Scaleable Upright(4) Bold(1) CLEVELAND OS (414) ESC: ESC@w0a041400	ABCDefgh123?!#\$%&'()*<>/
1010	EPSON 8... P: Scaleable Upright(0) Light(-3) SUBSSELE Lt (443) ESC: ESC@w0a044300	ABCDefgh123?!#\$%&'()*<>/
1011	EPSON 8... P: Scaleable Upright(0) Bold(1) SUBSSELE Bd (443) ESC: ESC@w0a044300	ABCDefgh123?!#\$%&'()*<>/
1012	EPSON 8... P: Scaleable Italic(1) Light(-3) SUBSSELE Lt It (443) ESC: ESC@w0a044300	ABCDefgh123?!#\$%&'()*<>/
1013	EPSON 8... P: Scaleable Italic(1) Bold(1) SUBSSELE Bdt (443) ESC: ESC@w0a044300	ABCDefgh123?!#\$%&'()*<>/
1014	EPSON 8... P: Scaleable Upright(0) Medium(0) UTAN Reg (4148) ESC: ESC@w0a041480	ABCDefgh123?!#\$%&'()*<>/01
1015	EPSON 8... P: Scaleable Upright(0) Bold(1) UTAN Bd (4148) ESC: ESC@w0a041480	ABCDefgh123?!#\$%&'()*<>/01
1016	EPSON 8... P: Scaleable Italic(1) Medium(0) UTAN It (4148) ESC: ESC@w0a041480	ABCDefgh123?!#\$%&'()*<>/01
1017	EPSON 8... P: Scaleable Italic(1) Bold(1) UTAN Bdt (4148) ESC: ESC@w0a041480	ABCDefgh123?!#\$%&'()*<>/01

PRINT FONTS I

Fig. 2-24 Test Pattern, Setting List, and Font List

Checking the Printed Test Pattern

After you print out the test pattern as described in the previous section, take a look at the printed sheet to check print quality.

The printer has been shipped with the print density properly adjusted with the control panel switches. If you are not satisfied with the printout (too light or dark for example), adjust the print density as follows:

1. Turn on the printer.
2. Press the SEL switch to set the printer off-line state.
3. Press the MODE switch.
4. Press the ▲ or ▼ switch to scroll through the display until the "ADVANCED MODE" appears.
5. Press the SET switch.
6. Press the ▲ or ▼ switch to scroll through the display until the "PRINT DENSITY" appears.
7. Press the SET switch.
8. Press the ▲ or ▼ switch until the desired print density value appears.

The value can change from 1 (light) to 15 (dark).

9. Press the SET switch.
10. Press the SEL switch to exit from the mode menus and set the printer on-line state.

For more information, see "MODE Switch" in Chapter 4.

CHAPTER 3

BEFORE WORKING WITH THE PRINTER

SOFTWARE COMPATIBILITY

Before working with your application software, you need to set up or install the printer driver in your software. Locate the printers that your application software supports and install the desired printer driver. Each software package differs in the way the printer driver is selected. Read the software manual and follow the setup or installation procedures.

Be sure to select the printer emulation mode that matches the installed printer driver. This printer emulates particular printer models of the following manufacturers. Since this printer has been factory set with the automatic emulation selection on, you may not need to select the emulation mode. When necessary, select the appropriate printer emulation mode with the panel switches according to the printer driver installed in your application software. See “CHAPTER 4 CONTROL PANEL.”

Printer Driver	Emulation Mode
* HL-1260/960 (See Note 1)	HP LaserJet 4
HL-10h (See Note 2)	HP LaserJet 4
HP LaserJet 4 (See Note 3)	HP LaserJet 4
HL-10V/DV	HP LaserJet 4
HP LaserJet III™	HP LaserJet 4
HP LaserJet IIID™	HP LaserJet 4
HP LaserJet Series II™	HP LaserJet 4
HP LaserJet IID™	HP LaserJet 4
HP LaserJet Plus™	HP LaserJet 4
* HP 7475A™	HP-GL
HP-GL™	HP-GL
* EPSON FX-850	EPSON FX-850
EPSON FX-80™	EPSON FX-850
* IBM Proprinter XL	IBM Proprinter XL
IBM Proprinter®	IBM Proprinter XL

To get the most out of this printer, you need to install the printer driver for this printer or the HP LaserJet 4 and select the HP LaserJet 4 emulation mode: this is the best combination. When any other HP LaserJet series printer driver is installed, select the HP LaserJet 4 emulation mode. When any other printer driver is installed, select the HP-GL, EPSON, or IBM emulation mode according to the installed printer driver.

An asterisk (*) indicates the best or recommended combination of the printer driver and emulation mode. Be sure to use any of these best or recommended combinations if circumstances permit. When an emulation mode other than the HP mode is selected, the printout may differ slightly from the printout that the target printer produces.

For Windows 3.1 users, to get the best performance from your printer, install the driver supplied with your printer.

 **Note 1:**

When the HL-1260 printer driver has been chosen (using the application software), the following fonts will be replaced printed using different fonts.

Albertville, Extrabold
Antique Oakland, Oblique, Bold
Atlanta Book, BookOblique, Demi, DemiOblique
Bermuda Script
BR Symbol
Calgary MediumItalic
Copenhagen Roman, Italic, Bold, BoldItalic
Germany
Helsinki, Oblique, Bold, BoldOblique
Letter Gothic, Oblique, Bold
Oklahoma, Oblique, Bold, BoldOblique
OCR-A
PC Brussee Light, LightItalic, Demi, DemiItalic
Portugal Roman, Italic, Bold, BoldItalic
San Diego
Tennessee Roman, Italic, Bold, BoldItalic
US Roman
Utah Condensed, Oblique, Bold, BoldOblique
W Dingbats

 **Note 2:**

When the HL-10h printer driver has been chosen (using the application software), the following fonts will be replaced printed using different fonts.

Albertville, Extrabold
Antique Oakland, Oblique, Bold
Atlanta Book, BookOblique, Demi, DemiOblique
BR Symbol
Calgary MediumItalic
Copenhagen Roman, Italic, Bold, BoldItalic
Helsinki, Oblique, Bold, BoldOblique
Letter Gothic, Oblique, Bold
Oklahoma, Oblique, Bold, BoldOblique
OCR-A
PC Brussee Light, LightItalic, Demi, DemiItalic
Portugal Roman, Italic, Bold, BoldItalic
Tennessee Roman, Italic, Bold, BoldItalic
Utah Condensed, Oblique, Bold, BoldOblique
W Dingbats

 **Note 3:**

When the LaserJet4 printer driver has been chosen (using the application software), the following fonts will be replaced and printed using different fonts.

Albertus, Extrabold
Antique Olive, Italic, Bold
LetterGothic, Italic, Bold
CG Omega, Italic, Bold, BoldItalic
Univers Medium Condensed, Italic, Bold, BoldItalic
Symbol
Arial, Italic, Bold, BoldItalic
Times New Roman, Italic, Bold, BoldItalic
Wingdings

AUTOMATIC EMULATION SELECTION

This printer has an automatic emulation selection function. When the printer receives data from the computer, it automatically selects the emulation mode. This function has been factory set to ON.

The printer can select the emulation among the following combinations:

EPSON/IBM Priority	EPSON (default)	IBM
Auto Selection Mode	HP LaserJet 4 HP-GL EPSON FX-850	HP LaserJet 4 HP-GL IBM Proprinter XL

To get the most out of this laser printer, we recommend you use the HP LaserJet 4 emulation mode, which is a true laser printer mode. Since the HP LaserJet 4 mode takes the highest priority in the automatic emulation selection, you can start using the printer as it is with the factory settings in most cases.

When the automatic emulation selection is active, you can check the current emulation on the display. When the printer is in ready, print, or wait states, the display reads as follows:

Emulation	Status Display in Ready State
HP LaserJet 4	LJ READY 001P T1
HP-GL	GL READY 001P T1
EPSON FX-850	FX READY 001P T1
IBM Proprinter XL	PR READY 001P T1

To select the emulation mode manually, use the EMULATION switch. For further information, see “EMULATION Switch” in Chapter 4.

 **Notes**

When you use the automatic emulation selection, note the following:

- Once the emulation is automatically changed, it is not changed again for a short period of time. This time period is called “Time Out” and it can be set with the EMULATION switch. The factory setting is 5 seconds.
- The EPSON or IBM emulation mode priority must be selected, as the printer cannot distinguish between them. Since the factory setting is the EPSON emulation mode, you might need to select the IBM emulation mode with the EMULATION switch when you need to use this emulation..
- Try this function with your application software or network server. If the function does not work properly, select the required emulation mode manually using the printer panel switches or use emulation selection commands from your software.

AUTOMATIC INTERFACE SELECTION

This printer has an automatic interface selection function. When the printer receives data from the computer, it automatically selects the bi-directional parallel or RS-232C serial interface as appropriate.

When you use the parallel interface, you can turn the high-speed and bi-directional parallel communications on or off with the MODE switch. For further information, see “MODE Switch” in Chapter 4. Since the automatic interface selection mode has been factory set to ON, simply connect the interface cable to the printer.

When you use the serial interface, you need to have the same communications settings on both the printer and computer. Since the automatic interface selection mode has been factory set with certain settings, you may be able to simply connect the interface cable to the printer if your computer has the settings listed below.

Communications Parameters	Factory Settings
Baud rate (data transfer speed)	9600
Code type (data length)	8 bits
Parity (data error check)	None
Stop bit (data separator)	1 stop bit
Xon/Xoff (handshake protocol)	ON
DTR (ER)	ON
Robust Xon	OFF

When necessary, select the interface or the serial communications parameters manually with the MODE switch (INTERFACE MODE) on the printer. For further information, see “MODE Switch” in Chapter 4. For the settings on the computer, see the manual of the computer or software you are using.

 **Notes**

When you use the automatic interface selection, note the following:

- Once the interface is automatically changed, it is not changed again for a short period of time. This time period is called “Time Out” and it can be set with the MODE switch. The factory setting is 5 seconds.
- The communications parameters [baud rate, code type, parity, stop bit, Xon/Xoff, DTR(ER), and Robust Xon] must be set for the serial interface. Although they have been factory set as shown in the above table, you may need to change them with the MODE switch.
- This function takes a few seconds to work. If you want to speed up printing, select the required interface manually with the MODE switch.

If you constantly use only one interface, we recommend that you select that interface in the interface mode. The printer allocates all of the input buffer to that interface if only one interface is selected.

ABOUT THE CONTROL PANEL

Adjusting the Control Panel Angle

You can adjust the control panel to the desired angle, so you can easily read the display messages.

To adjust the angle of control panel, gently pinch the tab on the right side of the panel and move the control panel up and down.

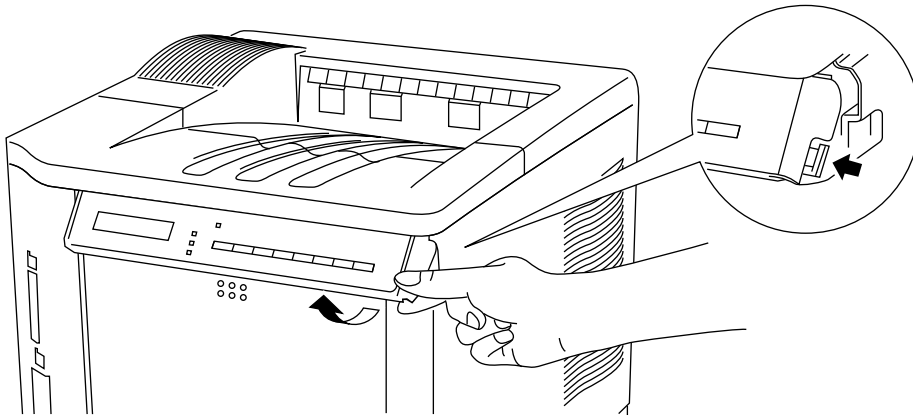

Fig. 3-1 Adjusting the Control Panel Angle

Selecting the Local Language Display

The display usually shows the current printer status. When you operate the control panel switches, it shows functions and settings. If any trouble occurs, it shows the corresponding error message. You can see these messages in several languages. The default language is English.

- English • German • Spanish • Norwegian • Danish
- French • Dutch • Italian • Finnish • Portuguese

To change to another language:

1. Turn off the printer.
2. Hold down the FORM FEED switch and turn on the printer.

The message "SELF TEST" appears and then the message changes to "LANG.=ENGLISH *".

3. Press the ▲ or ▼ switch until your desired language appears on the display.
4. Press the SET switch to make the selected language message effective.

An asterisk (*) appears at the end of the display for a short time, and then the printer automatically returns to on-line state with the selected language message on the display.

Using the Panel Switches

The printer has a versatile control panel. It has two operation modes:

When you press the switches, they work in the **NORMAL** mode as indicated above the switches. When you press the switches with the **SHIFT** switch held down, they work in the **SHIFT** mode as indicated below the switches. You can control the basic printer operations and make various printer settings in the **NORMAL** and **SHIFT** modes.

For further information, see “**SWITCHES IN NORMAL MODE**” and “**SWITCHES IN SHIFT MODE**” in Chapter 4.

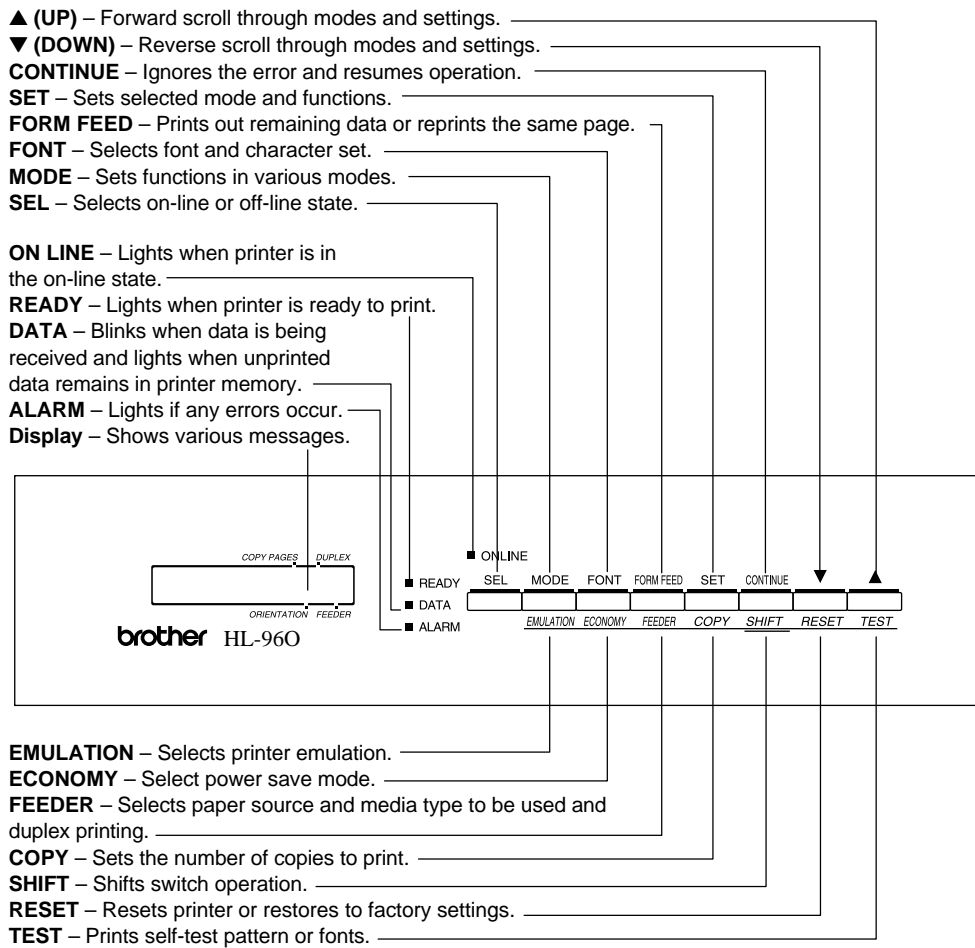

Fig. 3-2 Switch Operation in NORMAL and SHIFT Modes

Printer Settings

You may operate the printer with the panel switch settings unchanged. They have been factory set. When necessary, change and store them in the printer memory as user settings.

There are two types of printer settings available on this printer:

1. User Settings
2. Factory Settings

Remember that the user settings override the factory settings. The user settings are effective until other settings are made or they are restored to the factory settings.

User Settings

Although the printer settings have been factory set, you can change them with the control panel switches. Since this printer has a memory, you can store the panel switch settings in the memory as "User Settings." They are recalled every time you turn on the printer.

In addition to the current settings, you can save two more sets of user settings with the MODE switch and restore to them with the RESET switch. The current settings are cleared after restoring one of the saved user settings.

Factory Settings

The printer settings have been set at the factory before shipment. They are called "Factory Settings." Although you can operate the printer with these factory settings unchanged, you can tailor the printer by making user settings.

Note

Changing the user settings does not affect factory settings. You cannot modify the preset factory settings.

The changed user settings can be restored to the factory default settings with the RESET switch. For further information, see "RESET Switch" in Chapter 4.

PAPER HANDLING

Print Media

Paper Size

1. The upper paper cassette

Since the paper cassette is a universal type, you can use any of the sizes of paper in the list. The cassette can hold up to 500 sheets of paper (80 g/m² or 20 lbs.) or up to 40 envelopes. (Paper should only be loaded up to the arrow head marked on the sliding guide.)

2. The multi-purpose tray

The multi-purpose tray is the most useful feeder for you to handle many types of paper. The multi-purpose tray can hold up to 150 sheets of paper (80 g/m² or 20 lbs.) or up to 15 envelopes.

The paper types and sizes that can be fed from the multi-purpose tray are as follows:

- Plain paper from 90 mm x 148 mm (3.5" x 5.8") to 216 mm x 356 mm (8.5" x 14") [Weight = 60 to 135 g/m² (16 to 36 lbs)]
- Overhead projector (OHP) films
- Colored paper
- Postcards
- Label stock
- Envelopes of COM10, Monarch, C5, DL, or ISO B5 size

3. The optional lower paper cassette

The cassette can hold up to 500 sheets of paper (80 g/m² or 20 lbs.). It has a limitation on the paper sizes that can be used as shown in the list.

4. The duplex unit

The duplex unit can handle letter, legal, A4, Executive and ISO B5 (except Tray 2) size papers from the feeders.

USER'S GUIDE

paper source	available size	available type and capacity
the multi-purpose tray (MP)	cut sheet : letter, legal, A4, ISO B5, Executive, A5, ISO B6 and A6 envelope: COM 10, Monarch, C5, DL and ISO B5 other size: wide 90-216mm (3.5"-8.5") long 148-356mm (5.8"-14")	plain paper : 150 envelope : 15 OHP film : 100 label stock : 100 other type : weight = 60 to 135 g/m ² (16 to 36 lbs)
the upper paper cassette (T1)	cut sheet : letter, legal, A4, ISO B5, Executive, A5, ISO B6 and A6 envelope :COM 10, Monarch, C5, DL and ISO B5	plain paper : 500 weight = 60 to 105 g/m ² (16 to 28 lbs) envelope : 40
the optional lower paper cassette (T2)	cut sheet : letter, legal, A4, Executive	plain paper : 500 weight = 60 to 90 g/m ² (16 to 24 lbs)
all sources for duplex printing (DX)	cut sheet : letter, legal, A4, ISO B5(except T2) and Executive	* The capacity of T1 is reduced from the above specified capacities with the duplex unit installed.

Using Envelopes

Avoid using envelopes with the following characteristics:

- Smooth or shiny surfaces
- Protection cover at envelopes' adhesive parts
- Sealing flaps that have not been folded at purchase
- Sealing flaps as shown below

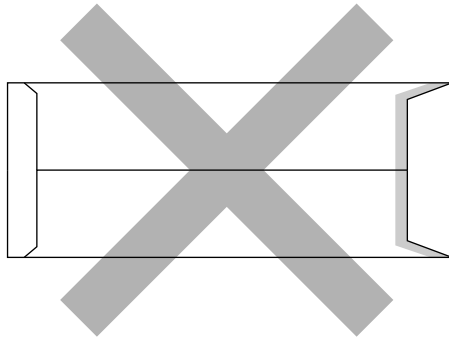

- Three or more layers of paper in the marked area

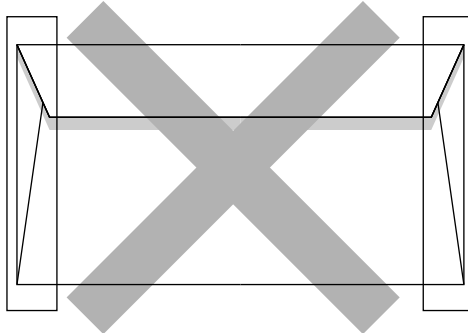

- Each side folded as shown below

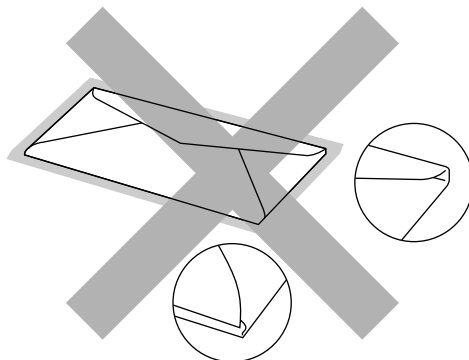

Fig. 3-3 Envelope Information

Before loading envelopes in the cassette, check the following:

- Envelopes should have a lengthwise sealing flap.
- The sealing flaps should be crisply and correctly folded (irregularly cut or folded envelopes may cause paper jams).
- Envelopes should consist of two layers of paper in the following marked area.

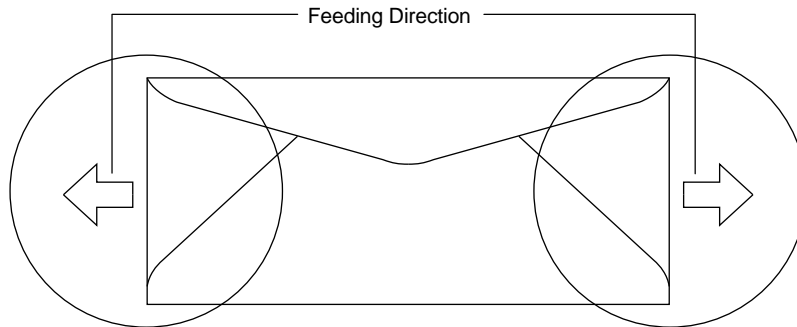

Fig. 3-4 Envelopes

Note

If envelopes get smudged during printing, set the print density to a higher value in the ADVANCED MODE with MODE switch for darker printouts. To adjust the print density setting, see "Checking the Printed Test Pattern" in Chapter 2.

- Envelope joints that are sealed by the manufacturer should be secure.
- All sides should be properly folded without any wrinkles or creases.

Cassette Feed

The printer can feed paper from the multi-purpose tray, the upper or the optional lower paper cassette. You can select the multi-purpose tray as a paper cassette with the FEEDER switch. Since the auto paper feed mode has been factory set, the printer usually feeds paper from the upper paper cassette. When the optional lower paper cassette is installed and the upper paper cassette runs out of paper, the printer automatically switches to the lower paper cassette. When the lower paper cassette runs out of paper or it is not installed, the printer automatically switches to the multi-purpose tray (T1>T2>MP) and feeds from there as long as they contain paper of the same size. When necessary, select the feeder with the FEEDER switch. For further information, see “FEEDER Switch” in Chapter 4. For information about the lower paper cassette, see “LOWER TRAY UNIT” in Chapter 5.

Notes

When you load paper into the multi-purpose tray or the paper cassette, note the following:

- If you use the multi-purpose tray, the paper size has to be manually set in the MP TRAY SETTING mode with the FEEDER switch.
- If your application software supports paper size selection on the print menu, you can select it through the software. If your application software does not support it, you can set the paper size with the MODE switch.
- The paper size has been factory set to letter for 110/120V models or A4 for 220/240V models. If you want to use other sizes of paper or envelopes, change the paper size in the PAGE FORMAT MODE of the FORMAT MODE with the MODE switch. For paper size selection, see “MODE Switch” in Chapter 4.
- If you use pre-printed paper in the cassettes, please note that the paper should be loaded with the printed side face down and the top of the paper to the front of the cassette. If you use pre-printed paper in the multi-purpose tray, the paper should be loaded with the printed side face up and the top of the paper towards the printer.

You can set the paper size for the paper cassette with the MODE switch in the PAGE FORMAT mode. The printer automatically detects the paper size you set in the paper cassette. If you load a different size of paper in the paper cassette from the size selected with the MODE switch or through your application software, the printer prompts you to set the proper size of paper as follows:

LOAD PAPER	↔	**** SIZE
------------	---	-----------

(**** indicates the paper size you have selected with the MODE switch in the PAGE FORMAT mode or through your application software.)

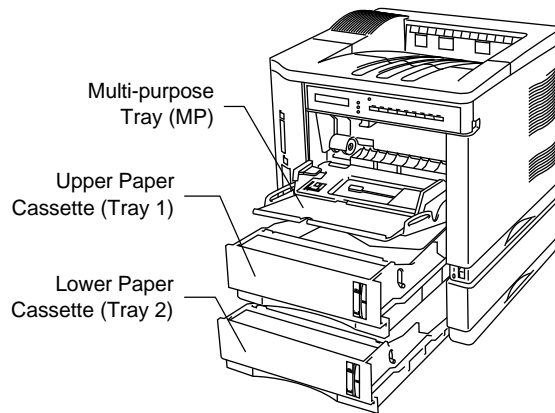

Fig. 3-5 Cassette Feed

Manual Feed

When you set paper in the multi-purpose tray with the setting **MANUAL FEED = ON** selected with the **FEEDER** switch, the printer loads paper only from the multi-purpose tray regardless of the previous feeder selection. When you select the setting **PAPER IN = CONT** in the **MP TRAY SETTING** mode, the printer loads paper automatically from the multi-purpose tray. When you select the setting **PAPER IN = STOP**, the printer waits for you to press the **SEL** key to start printing. You can set the paper feed mode and the paper size with the **FEEDER** switch. For further information, see “**FEEDER Switch**” in Chapter 4.

Notes

When you feed paper manually, note the following:

- If your application software supports a manual feed selection in the print menu, you can select it through the software. Since the software or command setting overrides the switch setting, you do not need to set the manual feed mode and the paper size with the **FEEDER** switch.
- If you use pre-printed paper in the multipurpose tray, please note that it is inserted with the pre-printed side face up. Insert the top of the page towards the printer in the multi-purpose tray.

Face Down Print Delivery

The printer normally ejects paper onto the top of the printer with the printed page face down.

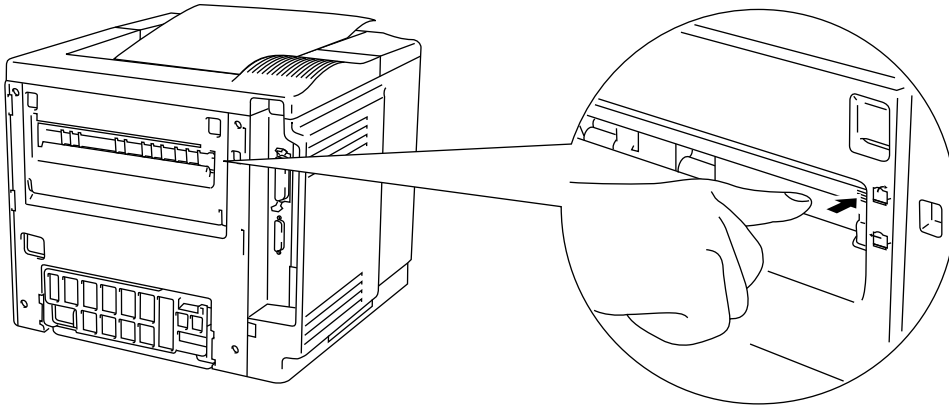

Fig. 3-6 Face Down Print Delivery

Face Up Print Delivery

You can change the print delivery path from the top to the rear of the printer. Push down the knob located inside the rear paper slit on the left of the paper path selector guide.

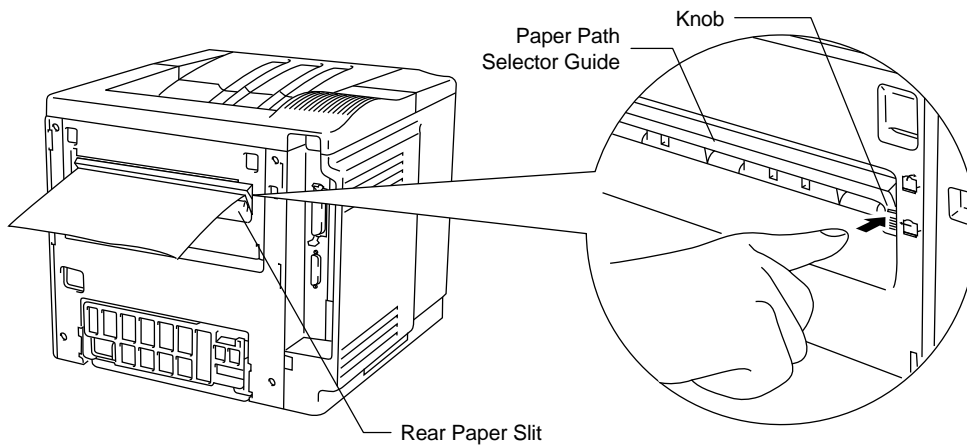

Fig. 3-7 Face Up Print Delivery

The printer ejects paper through the rear paper slit with the printed page face up.

Note

After you have finished face up print delivery, be sure to reset the knob to switch back to the face down print delivery.

USER'S GUIDE

CHAPTER 4 CONTROL PANEL

DISPLAY AND LAMPS

This printer has one liquid crystal display (LCD) and four lamps on the control panel. The display can show various messages with up to 16 characters. The lamps light to indicate the current printer status.

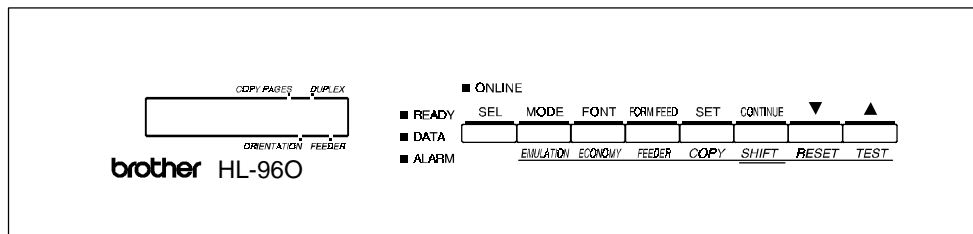

Fig. 4-1 Display and Lamps

Display

The display usually shows the current printer status. When you operate the control panel, you can change settings interactively on the display.

When you turn the printer off-line, the display changes to show the currently selected emulation and informs you that you can make the settings in the current emulation.

If any problems occur, the display shows the corresponding operator call, error, or service call message to prompt you to take an action. For more information on these messages, see "TROUBLESHOOTING" in Chapter 7.

Printer Status Messages

The following table shows the printer status messages that are displayed during normal operation:

Printer Status Message	Meaning
00 READY 001P T1	The printer is ready to print.
AUTO LaserJet 4	The printer is off-line and currently in HP LaserJet 4 mode under AUTO emulation mode selected.
HP LaserJet 4	The printer is off-line and in HP LaserJet 4 mode under HP LaserJet 4 emulation mode selected.
00 SLEEP 001P T1	The printer is in sleep status (power save mode).
01 PRINT 001P T1	The printer is printing.
01 PR300 001P T1	The printer is printing decreasing the resolution from 600 dpi to 300 dpi because of insufficient memory.
01 SX 001P T1	The printer is printing in the simplex mode due to insufficient memory for the selected duplex mode.
02 WAIT 001P T1	The printer is warming up.
04 SELF TEST	The printer is performing self-diagnosis.
05 TEST PRINT	The printer is printing the test pattern.
06 PRINT CONFIG	The printer is printing the list of the current printer settings.
06 PRINT FONTS I	The printer is printing the list of the internal or resident fonts.
06 PRINT FONTS C	The printer is printing the list of the optional fonts stored in an installed font cartridge/card.
06 PRINT FONTS P	The printer is printing the list of the permanent download fonts.
06 CARD PRINT	The printer is printing the contents of a flash memory card or a HDD card.

Printer Status Message	Meaning	(Continued)
07 FF PAUSE	The printer has suspended feeding forms. Pressing the SEL switch resumes form feed.	
08 RESET TO USER SETTINGS	The printer is restoring itself to the user settings you made with the panel switches. (The message appears only momentarily.)	
09 RESET TO FACTORY SETTINGS	The printer is restoring itself to the factory settings. (The message appears only momentarily.)	

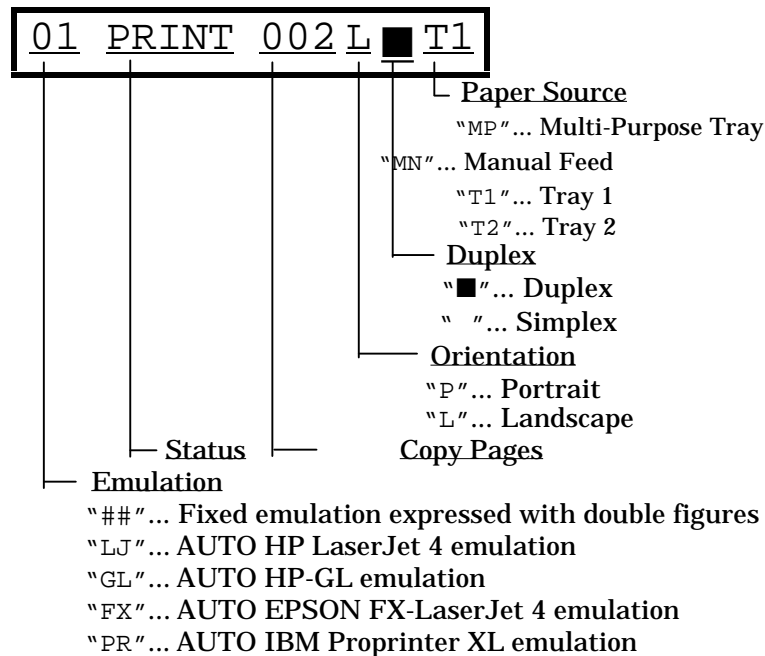

Fig. 4-2 Display

Lamps

The lamps light or blink to indicate the current printer status.

READY

LED indication	Meaning
On	Ready to print
Blinking	Warming up

DATA

LED indication	Meaning
On	Data remains in the printer buffer. Pressing the FORM FEED switch prints the data and clears the buffer.
Blinking	Receiving or processing data

ALARM

LED indication	Meaning
On	Some problem has occurred in the printer.

ON LINE

LED indication	Meaning
On	The printer is on-line and ready to print
Off	The printer is off-line and stops printing.

SWITCHES IN NORMAL MODE

You can control the basic printer operations and change various printer settings in the NORMAL mode. Functions available in the NORMAL mode are shown above the panel switches.

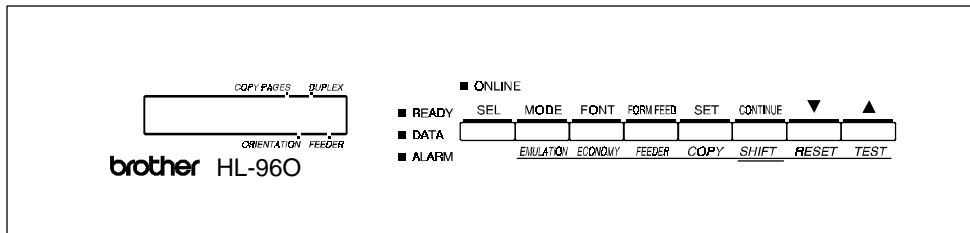

Fig. 4-3

Switches in NORMAL Mode

Note

The factory settings are printed in bold in this section.

SEL Switch

Pressing the SEL switch changes the state of the printer between on-line and off-line. When the printer is on-line, the ON LINE lamp lights and the printer is ready to receive data from the computer. When the printer is off-line, the ON LINE lamp is off.

To receive data from the computer, set the printer on-line. To operate the control panel switches, set the printer off-line.

When you press the SEL switch when the printer is the on-line state, it turns off-line and the LCD displays the current emulation mode.

AUTO LaserJet 4

You can enter other emulations in the auto emulation mode by pressing the ▲ (UP) or ▼ (DOWN) switch.

 **Notes**

When you press the SEL switch, remember the following:

- All other switches—except the SEL switch—are operational only when the printer is off-line.
- If the printer is not in auto emulation mode, the LCD displays the current emulation by pressing the SEL key to take it off-line, but you can not enter other emulation modes. To make settings in other emulation modes, press the EMULATION switch and select the emulation.
- The SEL switch works as a “quick exit” switch. If you are lost in the display menus or you want to quickly exit the display menu, press the SEL switch. You can exit quickly from any depth of the display menu to the on-line ready state. If you have already made a setting effective by pressing the SET switch and then press the SEL switch to quickly exit, your setting (whether made by accident or on purpose) will remain effective. Pressing the SEL switch will not cancel any setting.

SET Switch

Pressing the SET switch allows you to select certain items on the display or make the displayed menu or setting effective. The switch also works as an execute switch to perform the displayed function.

When you press the SET switch, the printer stores the settings you have selected into the memory as “User Settings.” Every time you turn on the printer, it is reset according to these user settings. They remain effective until you make new settings or restore them to the factory settings. For factory reset, see “RESET Switch” in this chapter.

 **Note**

When you press the SET switch to select a setting, an asterisk appears at the end of display for a short time. Since the asterisk indicates the selection, you can easily find the current setting when you scroll through the display.

▲ (UP) or ▼ (DOWN) Switch

Pressing ▲ (UP) or ▼ (DOWN) switch scrolls the menus and settings forward or backward respectively on the display. Press or keep pressing the switch until you access the desired item.

MODE Switch

Pressing the MODE switch allows you to enter modes where you change settings. The mode menus and settings vary according to the current emulation mode and options. For details, refer to the pages indicated in parentheses.

HP LaserJet 4, EPSON
FX-850, and IBM Proprinter XL
Modes

INTERFACE MODE

Set interface, parameters. (4-15)

FORMAT MODE

Set orientation, paper size, margins,
& others. (4-18)

RESOLUTION MODE

Set resolution. (4-26)

PAGE PROTECTION

Protect data on a page. (4-28)

CARD OPERATION

Set a flash memory card or a HDD
card in HP mode. (4-29)

ADVANCED MODE

Set network mode, print density, &
others. (4-37)

PAGE COUNTER

Show # of printed pages. (4-43)

exit MODE

Exit to off-line ready state. (4-43)

HP-GL Mode

INTERFACE MODE

Set interface, parameters. (4-15)

FORMAT MODE

Set orientation, paper size, margins,
pen setting & others. (4-18)

RESOLUTION MODE

Set resolution. (4-26)

PAGE PROTECTION

Protect data on a page. (4-28)

CARD OPERATION

Set a flash memory card or a HDD
card. (4-29)

ADVANCED MODE

Set network mode, print density, &
others. (4-37)

PAGE COUNTER

Show # of printed pages. (4-43)

exit MODE

Exit to off-line ready state. (4-43)

MODE Switch Settings in HP LaserJet 4, EPSON FX-850, and IBM Proprinter XL Modes

The following table shows all the selections you can make with the MODE switch in the HP LaserJet 4, EPSON FX-850, and IBM Proprinter XL modes.

Note
The mode menus and settings that can appear vary according to the current emulation mode, printer status, and any options that may be installed in the printer.

Mode Menu	Setting Menu	Sub-Setting Menu	Setting
INTERFACE MODE (See 4-15.)	I/F=PARALLEL	HIGH SPEED=ON	ON or OFF
		BI-DIR=ON	ON or OFF
	I/F=RS-232C	BaudRate= 9600	150, 300, 600, 1200, 2400, 4800, 9600, 19200, 38400, or 57600 baud
		CodeType=8 bits	7 or 8 bits
		Parity =NONE	NONE, EVEN, or ODD
		Stop Bit=1 bits	1 or 2 stop bits
		Xon/Xoff=ON	ON or OFF
		DTR (ER)=ON	ON or OFF
		Robust Xon=OFF	ON or OFF
		exit	Exit to INTERFACE MODE
	I/F=AUTO	TIME OUT= 5s	1 to 99 seconds
		PRL Setting	Bi-directional settings for AUTO
		HIGH SPEED=ON	ON or OFF
		BI-DIR=ON	ON or OFF
		exit	Exit to PRL Setting
		RS-232C Setting	Parameters for AUTO mode
		BaudRate= 9600	150, 300, 600, 1200, 2400, 4800, 9600, 19200, 38400, or 57600 baud
		CodeType=8 bits	7 or 8 bits
		Parity =NONE	NONE, EVEN, or ODD
		Stop Bit=1 bits	1 or 2 stop bits
		Xon/Xoff=ON	ON or OFF
		DTR (ER)=ON	ON or OFF
		Robust Xon=OFF	ON or OFF
		exit	Exit to RS-232C Setting

Mode Menu (Continued)	Setting Menu	Sub-Setting Menu	Setting
FORMAT MODE (See 4-18.)	ORIENTATION	ORI=PORTRAIT	PORTRAIT or LANDSCAPE
	AUTO MODE	AUTO LF=OFF	ON ... LF + CR OFF ... CR only
		AUTO CR=OFF	ON ... LF, FF, or VT + CR OFF ... LF, FF, or VT only
		AUTO WRAP=OFF	ON ... Auto wrap on OFF ... Auto wrap off
		AUTO SKIP=ON	ON ... Auto FF at bottom margin
		(HP mode)	OFF ... No FF at bottom margin
		AUTO MASK=OFF (EPSON & IBM modes)	ON ... Auto mask on OFF ... Auto mask off
		exit	Exit to AUTO MODE
	PAGE FORMAT MODE	PAPER =LETTER (For 110/120V model)	LETTER, LEGAL, A4, A5, A6, B5, B6, EXECUTIVE,
		PAPER =A4 (For 220/240V model)	COM10, MONARCH, C5 and DL
		LEFT M = 0C	0 to 126 columns
		RIGHT M = 80C (Letter, Portrait)	10 to 136 columns
		RIGHT M = 78C (A4, Portrait)	10 to 136 columns
		TOP M =0.5" (HP mode)	0, 0.33, 0.5, 1.0, 1.5, or 2.0"
		BOTTOM M=0.5" (HP mode)	0, 0.33, 0.5, 1.0, 1.5, or 2.0"
		LINES = 60L (HP, Letter, Portrait)	5 to 128 lines/page
		LINES = 64L (HP, A4, Portrait)	5 to 128 lines/page
		X OFFSET= 0	-500 (left) to +500 (right) dots
		Y OFFSET= 0	-500 (down) to +500 (up) dots
		exit	Exit to PAGE FORMAT MODE
	exit		Exit to FORMAT MODE
RESOLUTION MODE (See 4-26.)	RESOLUTION	RESOLUTION	300 or 600 dpi
	exit		Exit to RESOLUTION MODE
PAGE PROTECTION (See 4-28.)	PROTECT=AUTO		AUTO, OFF, LETTER, A4, or LEGAL
CARD OPERATION (HP mode only) (See 4-28.)	When the commercial flash memory card or the HDD card has not been formatted: FORMAT CARD		Format the flash memory card or the HDD card.
	exit		Exit to CARD OPERATION

USER'S GUIDE

Mode Menu (Continued)	Setting Menu	Sub-Setting Menu	Setting	
CARD OPERATION (HP mode only) (See 4-28.)	EXECUTE DATA		When the commercial flash memory card or the HDD card has been formatted: Execute the data on the card.	
		DATA ID=##### exit	Execute the selected data. Exit to EXECUTE DATA	
	CARD LIST		Print the contents of the card.	
	SAVE	SAVE DATA	Send data to be saved.	
		SET KEY--> END	End saving the data.	
		DATA ID=#####	Set data ID for saved data.	
		SAVE MACRO	Save a macro.	
		MACRO ID=#####	Set macro ID for saved macro.	
		PRIMARY FONT	Save primary font.	
		FONT ID=#####	Set primary font ID for saved font.	
		SECONDARY FONT	Save secondary font.	
		FONT ID=#####	Set secondary font ID for saved font.	
		DOWNLOAD FONT	Save download font.	
		FONT ID=#####	Set download font ID for saved font.	
		exit	Exit to CARD OPERATION	
		DELETE	MACRO ID=#####	Delete the selected macro.
			DATA ID=####	Delete the selected data.
	FONT ID=#####		Delete the selected font.	
	FORMAT CARD		Format the flash card.	
	SET -> DELETE ALL exit		Execute formatting the card. Exit to FORMAT CARD	
	exit	Exit to CARD OPERATION		
ADVANCED MODE (See 4-37.)	NETWORK MODE	LOCK PANEL=OFF	ON or OFF	
		PASS NO=###	Enter pass number.	
		AUTO FF=OFF	ON or OFF	
		WAIT TIME= 5s	1 to 99 seconds for AUTO ON	
		FF SUPPRESS=OFF	ON or OFF	
		TONER LOW=CONT	CONT or STOP	
		exit	exit to NETWORK MODE	
		CONTINUE MODE	CONTINUE=MANUAL	AUTO or MANUAL
	PRINT DENSITY	■■■■■	Increase or decrease the print density. (15 levels)	
	INPUT BUFFER	□□□□□	Increase or decrease the input buffer capacity. (15 levels)	
	SAVE SETTINGS	SAVE SETTING 1	Save the current setting as #1	
		SAVE SETTING 2	Save the current settings as #2	
		exit	exit to ADVANCED MODE	
	PAGE COUNTER (See 4-43.)	COUNT= 0		Shows the number of printed pages.
exit MODE (See 4-43.)			Exit MODE.	

MODE Switch Settings in HP-GL Mode

The following table shows all the selections you can make with the MODE switch in the HP-GL mode.

Note

The mode menus and settings that can appear vary according to the current emulation mode, printer status, and any options that may be installed in the printer.

Mode Menu	Setting Menu	Sub-Setting Menu	Setting
INTERFACE MODE			
Same as LaserJet 4 Mode (See 4-15.)			
FORMAT MODE (See 4-18.)	PAGE FORMAT MODE	PAPER=LETTER (For 110/120V mode)	LETTER, LEGAL, A4, A5, A6, B5, B6, EXECUTIVE, COM10, MONARCH, C5, and DL
		X OFFSET= 0	-500 (left) to +500 (right) dots
		Y OFFSET= 0	-500 (up) to +500 (down) dots
		exit	Exit to PAGE FORMAT MODE
GRAPHICS MODE		PEN SETTING	
		SETTING=PEN1	PEN1 to 6 (Set size and gray percentage for the selected pen.)
		SIZE #=3 dots	1 to 10 dots (pen size in dots) (# is the selected pen number.)
		GRAY #=100%	15, 30, 45, 75, 90, or 100% (# is the selected pen number.)
		exit	Exit to SETTING=PEN1- 6
		exit	Exit to GRAPHICS MODE
		CHARACTER SET	
		STANDARD SET	Standard character set
		ANSI ASCII	See character sets on page 4-26.
		ALTERNATE SET	Alternate character set
		ANSI ASCII	See character sets on page 4-26.
		exit	Exit to GRAPHICS MODE
	exit		Exit to FORMAT MODE
RESOLUTION MODE (See 4-26.)	RESOLUTION	RESOLUTION=600	300 or 600 dpi
	exit		Exit to RESOLUTION MODE

USER'S GUIDE

Mode Menu (Continued)	Setting Menu	Sub-Setting Menu	Setting
PAGE PROTECTION (See 4-28.)	PROTECT=AUTO		AUTO, OFF, LETTER, A4, or LEGAL
	exit		Exit to CARD OPERATION
CARD OPERATION (See 4-28.)	When the commercial flash memory card or the HDD card has not been formatted:		
	FORMAT CARD		Format the flash memory card or the HDD card.
	exit		Exit to CARD OPERATION
CARD OPERATION (See 4-28.)	When the commercial flash memory card or the HDD card has been formatted:		
	EXECUTE DATA		Execute the data on the card.
		DATA ID=#####	Execute the selected data.
		exit	Exit to EXECUTE DATA
	CARD LIST		Print the contents of the card.
	SAVE	SAVE DATA	Send data to be saved.
		SET KEY--> END	End saving the data.
		DATA ID=#####	Set data ID for saved data.
		exit	Exit to CARD OPERATION
	DELETE	MACRO ID=#####	Delete the selected macro.
		DATA ID=####	Delete the selected data.
		FONT ID=#####	Delete the selected font.
		FORMAT CARD	Format the card.
		SET -> DELETE ALL	Execute formatting the card.
		exit	Exit to FORMAT CARD OPERATION
	exit		Exit to CARD OPERATION
ADVANCED MODE Same as HP LaserJet 4 mode (See 4-37.)			
PAGE COUNTER (See 4-43.)	COUNT= 0		Shows the number of printed pages.
exit MODE (See 4-43.)			Exit MODE

Basic Operation Procedures

When you operate the MODE switch, remember the following basic steps:

1. Press the SEL switch to set the printer off-line.
2. Press the MODE switch to enter the MODE menus.

The first mode menu appears on the display.

INTERFACE MODE

- Press the ▲ or ▼ switch to scroll through the menus forward or backward. (Pressing the MODE switch allows forward scroll.)

INTERFACE MODE ←▼ or ▲→ FORMAT MODE
 ←▼ or ▲→ RESOLUTION MODE ←▼ or ▲→ ...

- Press the SET switch to enter the next lower menu level of the selected menu.

Mode Menu —SET→ Setting Menu —SET→ Sub-Setting Menu

- Press the ▲ or ▼ switch to select the setting on the display.

I/F=PARALLEL ←▼ or ▲→ I/F=RS-232C ←▼ or ▲→...

- Press the SET switch to make the selected setting effective.

Then

you move to the next selection or exit to the upper menu level.

When you see “exit” and press the SET switch, you can exit from the current level of menu to the next higher level of the menu.

3. Advance to “exit MODE” and press the SET switch to exit from the mode menus to the off-line ready state.

Pressing the SEL switch any time in any level of the menus allows you to exit from the mode menus to the on-line state. The settings you have made with the SET switch before exit are effective.

Operation Example: Selecting the Parallel Interface

For this session, select the parallel interface manually as follows:

1. Press the SEL switch to set the printer off-line.
2. Press the MODE switch.

The display shows the first menu.

INTERFACE MODE

3. Press the SET switch.

When you enter the interface mode, the display first shows the current interface with the asterisk.

I / F=AUTO *

4. Press the ▲ or ▼ switch until the desired interface appears on the display.

I / F=PARALLEL

Display Message	Interface Mode
I / F=PARALLEL	Parallel interface
I / F=RS-232C	Serial interface
I / F=AUTO	Auto interface selection

5. Press the SET switch to make the displayed selection effective.

An asterisk appears at the end of the display for a short time. Then the printer automatically exits from the setting menu to the interface menu.

INTERFACE MODE

6. Press the ▲ or ▼ switch until the exit menu appears on the display.

exit MODE

7. Press the SET switch.

Then the printer automatically returns to the off-line ready state.

INTERFACE MODE

The automatic interface selection has been factory set. If you want to select a specific interface manually, use the interface mode to set it.

Display Message	Interface Mode
I / F=PARALLEL	Parallel interface
I / F=RS-232C	Serial interface
I / F=AUTO	Auto interface selection

Select the setting menu and enter the sub-setting menu to change the setting as follows:

■ Automatic Interface Selection

When you use the automatic interface selection function, select the function on the display as follows:

I / F=AUTO

When you select this function with the SET switch, the display shows the next sub-setting menu as follows:

TIME OUT= 5s *

You need to set the time out for the auto interface selection from 1 to 99 seconds with the ▲ or ▼ switch: **factory setting = 5 seconds**. This time out is the duration during which the printer will not allow another automatic change to the interface.

Even if you choose the automatic interface selection, you need to set the communications parameters for the serial interface, high speed/bi-directional communications for the parallel interface. See the tables below.

For further information about automatic interface selection, see "AUTOMATIC INTERFACE SELECTION" in Chapter 3.

■ Parallel Interface

When you intend to use the bi-directional parallel interface, select the interface on the display as follows:

I / F=PARALLEL

When you use the parallel interface, you need to set the communications mode in the following sub-setting menu.

Display Message	High Speed and Bi-directional Parallel Communications
HIGH SPEED=ON	Turns on or off the high speed parallel communications.
BI-DIR=ON	Turns on or off the bi-directional parallel communications.

The above high-speed and bi-directional settings are used for the bi-directional parallel interface of this printer. The bi-directional parallel interface is compatible with the standard bi-directional parallel interface. Although it uses the same cable, hardware, and software as the bi-directional parallel interface, to use its enhanced capabilities—such as bi-directional communication between the computer and printer and faster transmission of data—you need printer driver or software that supports these features. Check with your software vendor to see if your software supports bi-directional parallel features.

■ Serial Interface

When you intend to use the serial interface, be sure to select the same communications parameters on both the printer and computer. You must set them for the automatic interface selection, too.

Display Message	Parameters	Settings
BaudRate= 9600	Baud rate (Data transfer speed)	150, 300, 600, 1200, 2400, 4800, 9600 , 19200, 38400, or 57600 baud
CodeType=8 bits	Code type (Data length)	7 bits or 8 bits
Parity =NONE	Parity (Data error check)	None , even, or odd
Stop Bit=1 bits	Stop bits (Data separator)	1 or 2
Xon/Xoff=ON	Xon/Xoff (Handshake protocol)	ON : DTR & Xon/Xoff handshake OFF : DTR handshake only
DTR(ER) =ON (Effective when Xon/Xoff=ON)	Data terminal ready (ER)	ON : Makes DTR (ER) low when the buffer is full. OFF : Does not make DTR (ER) low when the buffer is full. DTR(ER) goes low only when the printer is off-line.
Robust Xon =OFF (Effective when Xon/Xoff=ON)	Robust Xon	ON : Sends Xon while waiting. OFF : Sends Xon once, when the printer status changes from off-line to on-line.

FORMAT MODE

ORIENTATION

When you select "ORIENTATION", you can set portrait or landscape orientation.

Note

The ORIENTATION selection is effective in the HP LaserJet 4, EPSON FX-850, and IBM Proprinter XL modes. It does not work in the HP-GL mode.

This printer can print pages in portrait or landscape orientation. You can check the current orientation on the display.

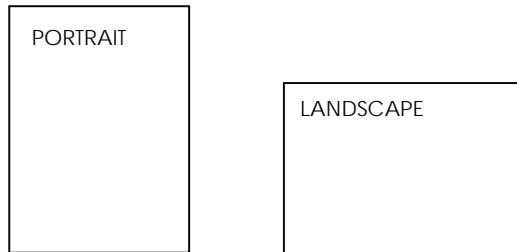

Fig. 4-4 Page Orientation

When you enter the setting mode, the display first shows the current orientation with an asterisk.

ORI=PORTRAIT *

Press the ▲ or ▼ switch until the desired orientation appears on the display.

Display Message	Orientation
ORI=PORTRAIT	Portrait
ORI=LANDSCAPE	Landscape

Press the SET switch to make the displayed selection effective.

An asterisk appears at the end of the display for a short time. Then the printer automatically exits from the setting mode to the FORMAT MODE.

When portrait has been selected, the display may look as follows:

```
00 READY 001P T1
```

When landscape has been selected, the display may look as follows:

```
00 READY 001L T1
```

AUTO MODE

Note

The settings in this mode menu are effective in the HP LaserJet 4, EPSON FX-850, and IBM Proprinter XL modes. They do not appear in the HP-GL mode.

The page/line termination is set in this mode.

Display Message	Setting	Auto Mode
AUTO LF =OFF	ON	CR → CR+LF
	OFF	CR → CR
AUTO CR =OFF	ON	LF → LF+CR, FF → FF+CR, VT → VT+CR
	OFF	LF → LF, FF → FF, VT → VT
AUTO WRAP =OFF	ON	Line feed and carriage return occur when the printer position reaches the right margin.
	OFF	No line feed and carriage return occur when the printer position reaches the right margin.
AUTO SKIP =ON	ON	Form feed occurs when the printer position reaches the bottom margin.
	OFF	No form feed occurs when the printer position reaches the bottom margin.
AUTO MASK =OFF	ON	The printer ignores the top and bottom margin settings you make with the control panel. The page length is automatically set to 11" for letter or A4-size paper and to 14" for legal-size paper.
	OFF	The printer operates according to the margin settings you make with the control panel.

Note on "AUTO MASK"

When you use application software in non-HP modes, be sure to set "AUTO MASK" to ON. When you use letter- or A4-size paper, the top and bottom 2 lines are masked and they do not appear on the printout.

The auto modes are subject to the current emulation mode.

- : The auto modes can be set.
- × : The auto modes cannot be changed and no setting appears.
- : The auto modes are not available.

AUTO Mode	Printer Emulation (Factory settings in bold print)		
	HP LaserJet 4	EPSON FX-850	IBM Proprinter XL
AUTO LF	○ OFF	○ OFF	○ OFF
AUTO CR	○ OFF	× ON	○ OFF (Note)
AUTO WRAP	○ OFF	× ON	× ON
AUTO SKIP	○ ON	—	—
AUTO MASK	—	○ OFF	○ OFF

Note

In the IBM emulation mode, FF codes are always followed by a CR code.

PAGE FORMAT MODE

Notes

The settings in this mode menu vary as follows:

- All settings are effective in the HP LaserJet4, EPSON FX-850, and IBM Proprinter XL modes.
- The paper size and the X and Y (vertical and horizontal) offsets are effective in the HP-GL mode. Other settings are not effective and they do not appear in this mode.

The following settings can be made in this mode:

Display Message	Page Format Mode
PAPER =LETTER	Set cut sheet paper size to letter, A4 , legal, B5, A5, B6, A6, or executive, or envelope size to COM10, Monarch, C5, or DL.
LEFT M = 0C P	Set the left margin at column 0 -126 at 10cpi.
RIGHT M = 80C P	Set the right margin at column 10-136 at 10cpi. See "List of Factory Settings" in this chapter.
TOP M = 0.5" P	Set the top margin at a distance from the top edge of the paper: 0, 0.33, 0.5 , 1.0, 1.5, or 2.0 inches. factory setting = 0.33 (Non-HP), 0.5 (HP)
BOTTOM M=0.5" P	Set the bottom margin at a distance from the bottom edge of the paper: 0, 0.33, 0.5 , 1.0, 1.5, or 2.0 inches. factory setting = 0.33 (Non-HP), 0.5 (HP)
LINES = 60L P	Set the number of lines per page from 5 to 128 lines. See "List of Factory Settings" in this chapter.

The letter "P" in the display messages indicates that the page orientation is portrait. The letter "L" is displayed when it is landscape.

Display Message	Page Format Mode (Continued)
X OFFSET= 0	Move the print start position (at the upper left corner on pages) horizontally up to -500 dots to the left or +500 dots to the right in 300dpi dot unit increments: factory setting = 0.
Y OFFSET= 0	Move the print start position (at the upper left corner on pages) vertically up to -500 dots downward or +500 dots upward in 300dpi dot increments: factory setting = 0.

Notes

When you make settings in PAGE FORMAT MODE, note the following:

- The letter size has been factory set for 110/120V model. The A4 size has been factory set for 220/240V model.
- When you use a smaller size of paper than that specified in the PAGE FORMAT MODE, be sure that the print area is smaller than the paper size, or the inside of the printer will get stained with toner. It is recommended that you perform a test before actual use: for this test, you could use a letter or A4 size of paper to see the printed area is completely inside the paper size you are going to use. This simple test will help prevent toner from being incorrectly applied to the inside of your printer, which may cause later print jobs to be smudged with toner.
- The factory settings of the right/left margins and lines vary according to the paper size and orientation. See the tables below.
- The top and bottom margins have been factory set to 0.5" in the HP emulation mode and to 0.33" in the non-HP emulation modes.
- The setting margins are subject to the current page orientation. The display shows the current orientation with "P" for portrait and "L" for landscape.
- Images offset outside the print area are not printed.

■ About Right and Left Margins

The settings range of the right and left margins are subject to the page orientation as follows. The right margin should be placed 10 columns greater than the left margin: minimum text width = 10 columns.

If the orientation is changed, the margin settings are restored to the factory settings. If the paper size is changed and the right and left margins exceed the paper size, they are restored to the factory settings: if they do not exceed the paper size, they remain effective.

The following table shows the settings range in columns. The factory settings are printed in bold.

Paper Size	Portrait		Landscape	
	Left Margin	Right Margin	Left Margin	Right Margin
Letter	0-70	10-80	0-96	10-106
A4	0-70	10-78-80	0-103	10-113
Legal	0-70	10-80	0-126	10-136

■ About Line Settings

Setting the number of lines/page automatically sets the line spacing or line feed pitch. If the paper size is changed, the number of lines/page changes accordingly. The new setting is calculated with the following expression and the remainder, if any, is ignored. However, the line feed pitch and the top and bottom margins remain effective.

$$\# \text{ of Lines/Page} = \frac{\text{Page Length} - (\text{Top Margin} + \text{Bottom Margin})}{\text{Line Feed Pitch [Vertical Motion Index (VMI)]}}$$

The setting of lines/page is subject to the current paper size and orientation. For example, when letter-sized paper is used, the printer can print 60 lines per page in portrait orientation. If the orientation is changed, the line settings are restored to the factory settings in that orientation.

The following tables show the factory settings in each emulation mode.

In HP Mode			In Non-HP Modes		
	Orientation			Orientation	
Size	Portrait	Landscape	Size	Portrait	Landscape
Letter	60 lines	45 lines	Letter	62 lines	47 lines
A4	64 lines	43 lines	A4	66 lines	45 lines
Legal	78 lines	45 lines	Legal	80 lines	47 lines

Note

When you use application software in the non-HP modes, the recommended settings are as follows:

- Left margin = column 0
- Right margin = Max. value
- Auto MASK ON

GRAPHICS MODE

Note

The settings in this mode menu are effective only in the HP-GL mode. They do not appear in any other emulation modes.

Since the HP-GL emulation mode is for a plotter, you can select the plotter pens, the pen size and percentage of gray in this mode menu.

Display Message	Graphics Mode
PEN SETTING	Set the size and percentage of gray separately for six plotter pens.
CHARACTER SET	Set the standard and alternate character sets.

Note

In most cases, the application software controls the above graphics mode settings, so you do not need to set them in this menu with the MODE switch. The software or command setting overrides the switch setting.

Select the setting menu and enter the sub-setting menu to make the settings as follows:

■ Pen Setting

When you select "PEN SETTING," you can set the size and percentage of gray for each plotter pen. You can make settings separately for six pens.

Select the pen with the ▲ or ▼ switch and enter the menu with the SET switch.

SETTING=PEN1

After you select the pen, advance to the sub-setting menu for size or gray-percentage selection with the ▲ or ▼ switch and enter the menu with the SET switch.

When the following message appears, the pen size can be set from 1 dot to 10 dots with the ▲ or ▼ switch:

SIZE 1=3 dots *

When the following message appears, the shades of gray can be set in 15, 30, 45, 75, 90, or 100% with the ▲ or ▼ switch.

GRAY 1=100% *

✍ Notes

- When another pen is selected, the display shows the selected pen with the number after “SIZE” or “GRAY.”
- Whichever resolution, 300 or 600 dpi, you have selected, the pen size takes effect in units of 300 dpi.

■ Character Set

When you select “CHARACTER SET,” you can select the standard and alternate character sets used in the HP-GL emulation mode.

Enter the sub-setting menu and select the menu for the standard or alternate character set with the ▲ or ▼ switch:

To set the standard character set, select the following message:

STANDARD SET

or

To set the alternate character set, select the following message:

ALTERNATE SET

Then press the SET switch to show the following message:

ANSI ASCII *

Change the character set with the ▲ or ▼ switch and make the selection effective by pressing the SET switch. For specific character sets, see “SYMBOL/CHARACTER SETS” in Appendix.

Character Sets in HP-GL Emulation Mode

ANSI ASCII (Factory setting)

9825 CHR. SET

FRENCH/GERMAN

SCANDINAVIAN

SPANISH/LATIN

JIS ASCII

ROMAN8 EXT.

ISO IRV

ISO SWEDISH

ISO SWEDISH:N

ISO NORWAY 1

ISO GERMAN

ISO FRENCH

ISO U.K.

ISO ITALIAN

ISO SPANISH

ISO PORTUGUESE

ISO NORWAY 2

RESOLUTION MODE

The resolution can be set in this mode menu.

Display Message	Resolution Mode
RESOLUTION	Set the resolution of the printer.

Select the setting menu and enter the sub-setting menu to make the settings as follows:

■ Resolution

When you select "RESOLUTION," you can choose a resolution of 300 or 600 dots per inch (dpi) on this printer. You can set the resolution in this mode according to your requirement.

The printer may not be able to print large files because of the resolution and the printer's memory. The higher the resolution and file size, the more memory is required.

Display Message	Resolution
RESOLUTION=600	Set the resolution to 600 dpi. (Factory setting)
RESOLUTION=300	Set the resolution to 300 dpi.

Select the print resolution in this mode according to the resolution required for your print jobs as shown below:

Print Jobs	Resolution Setting in Resolution Mode	
	300 dpi	600 dpi
300 dpi	For optimum print quality	For mixing 300 dpi bitmaps with 600 dpi
600 dpi	Not recommended	For optimum print quality

Note

Even if you set the resolution to 600 dpi in this mode, the printer may not be able to print large files at 600 dpi because of insufficient memory. However, it automatically decreases the resolution to 300 dpi to print them. While the printer is printing, the display prompts “01 PR300 ...”

If the printer cannot print files even at 300 dpi, the “MEMORY FULL” error occurs. See “TROUBLESHOOTING” in Chapter 7.

This automatic resolution decrease function works in any emulation modes with the page protection on. See also “PAGE PROTECTION” in this chapter.

When you want to print without decreasing the resolution, you must expand the memory capacity of the printer to 6-Mbytes or more. Do this by adding 4-Mbytes or more to the standard 2-Mbyte memory.

Expand the memory capacity referring to the table below.

Paper Size	300 dpi	600 dpi
Letter or A4	2 Mbytes	6 Mbytes
Legal	3 Mbytes	6 Mbytes
(Duplex printing)	4 Mbytes	10 Mbytes

For memory expansion, see “RAM EXPANSION” in Chapter 5 or consult the dealer where you purchased the printer.

PAGE PROTECTION

If print images are too complex to print, the printer may print them out in parts or only on part of the page. If this occurs, the printer loses print data and shows the following message:

31 PRINT OVERRUN

The page protection function reserves additional memory so that the printer can create the entire page image in memory before physically printing it out. This function can be set for letter, A4, or legal size paper. Select the paper size for page protection.

Display Message	Page Protection
PROTECT=AUTO	Page protection on only when it is necessary. (Factory setting)
PROTECT=LETTER	Page protection on for letter size paper.
PROTECT=A4	Page protection on for A4 size paper.
PROTECT=LEGAL	Page protection on for legal size paper.
PROTECT=OFF	Page protection off

To protect pages, you need the memory capacity as shown in the following table:

Protection	300 dpi	600 dpi
Off	2 Mbytes	2 Mbytes
Letter or A4	2 Mbytes	6 Mbytes
Legal	3 Mbytes	6 Mbytes
(Duplex)	4 Mbytes	10 Mbytes

Notes

When you use the page protection function, note the following:

- When you want to print at 600 dpi with the page protection function on, be sure to expand the memory capacity to a minimum of 6 Mbytes; or the resolution is automatically reduced to 300 dpi for printouts.
- If the function setting is changed, all download fonts and macros—including permanent ones—are cleared. If the memory is too low to protect pages, page protection does not take effect.

CARD OPERATION

Notes

- BE SURE TO TURN OFF THE PRINTER POWER SWITCH BEFORE INSTALLING OR REMOVING THE FLASH MEMORY CARD OR HDD CARD, OR THE CARD WILL BE DAMAGED.
- The settings in this mode menu are effective only when you have installed a flash memory card or a HDD card in the card slot of the printer and you have selected the HP LaserJet 4 or HP-GL mode. They do not appear when the printer has no card or is in any other emulation mode.
- If you turn the printer off or remove the flash memory card or the HDD card while data is being written onto or deleted from the card, all the data on the card may be lost.
- If the write protect switch of the flash memory card or the HDD card is on, this mode menu does not appear.

Be sure to install a commercial flash memory card or a HDD card in the upper card slot of the printer. For installation, see “FONT CARTRIDGE/CARD, FLASH MEMORY/HDD CARD” in Chapter 5.

When you are in this mode menu, you can save macros and fonts in the installed flash memory card or the HDD card.

The sub-setting menus displayed in this mode menu vary according to the state of the installed card.

When the installed card is not formatted:

When you enter this mode menu with the flash memory card or the HDD card installed but not formatted by this printer, you must first format the card.

Display Message	Card Operation
FORMAT CARD	Format a new flash memory card or HDD card.
exit	Exit to CARD OPERATION

When the display shows “FORMAT CARD,” press the SET switch to format the installed card.

After the printer finishes formatting the card, you exit to the “CARD OPERATION” menu.

✍ Notes

- If the card is formatted, data that has been previously written is erased.
- It takes ten or more seconds to format a 2-Mbyte flash memory card or a HDD card. The more the capacity of the card, the longer time it takes to format the card.

When the installed flash memory card or HDD card is formatted:

When you enter this mode menu with the formatted flash memory card or HDD card installed, the display shows the following menus:

Display Message	Flash Operation
EXECUTE DATA	Select the data ID and execute the selected data. This menu appears only when any data has been saved on the card.
CARD LIST	Print out the contents of the flash memory card or the HDD card. This menu appears only when anything has been saved in the card.
SAVE	Save received data, macros, and fonts.
DELETE	Delete items from the card.

✍ Note

A common use of the flash memory is with FORMS software packages. With these commercially available software packages you have an option to send a form to the printer without any data. After you send the form to the printer, you may save the form in the flash memory as a Macro. Then the next time you want to print this form, you would setup your FORMS software package to SEND DATA ONLY - USE FORM IN PRINTER. This process would save you anything from 1 to 4 minutes per print job.

Select the setting menu and enter the sub-setting menu to change the settings as follows:

■ Execute Data

✍ Note

This menu appears only when data has been saved on the card.

When you select "EXECUTE DATA," you can execute any of the data saved in the SAVE DATA mode.

When you enter this sub-setting menu with the SET switch, the printer prompts you to select the ID of the data.

DATA ID=#####

Select the ID with the ▲ or ▼ switch and press the SET switch again, so that the printer executes the selected data.

<p>Note PostScript® language data can not be printed correctly with this printer because it does not have BR-Script emulation.</p>

■ Card List

When you select “CARD LIST” and you press the SET switch, the printer automatically loads paper and starts printing the contents of the installed flash memory card or HDD card. You can check the contents and the unused capacity of the card.

■ Save

When you select “SAVE” and you press the SET switch, you can enter the following sub-setting menus to save the macros and fonts in the installed card:

Display Message	Save Menu
SAVE DATA	Save data that the printer will receive and set its ID.
SAVE MACRO	Save a macro. This menu appears only in the HP LaserJet 4 emulation mode.
PRIMARY FONT	Save the primary font selected with the FONT switch. This menu appears only in the HP LaserJet 4 emulation mode.
SECONDARY FONT	Save the secondary font selected with the FONT switch. This menu appears only in the HP LaserJet 4 emulation mode.
DOWNLOAD FONT	Save a download font. This menu appears only in the HP LaserJet 4 emulation mode.

<p>Note If the capacity of the card becomes low while macros and fonts are being saved, the display shows the “CARD FULL” error message and they cannot be saved. Use a new card or delete unnecessary macros and fonts from the card. The CARD LIST displays the contents and the used capacity.</p>
--

- Save Data

You can send data and save it on the card. In this mode, any kind of data such as PCL data and command strings can be saved. When you select "SAVE DATA" and you press the SET switch, the display shows the following guide menus.

SET KEY --> END

This message prompts you to press the SET switch again so that the printer exits from the data reception status when you finish sending data.

Send data from your computer.

✍ Notes

When you send data to be saved on the card, it is temporarily stored in the RAM of the printer. Note the following:

- If the received data exceeds the RAM capacity, a memory full error occurs. You can clear this error with the CONTINUE switch. When this error occurs, only part of the image has been stored in RAM, therefore, you cannot save the data to the card.
- The printer is reset to ensure as much capacity as possible in RAM. If any data remains, it is printed out first.

After you have finished sending data, press the SET switch again, so that the printer exits from the data reception status.

When you exit from the data reception status, you see the following message on the display:

DATA ID=#####

Select the data ID with the ▲ or ▼ switch and press the SET switch. The printer will then save the received data with the ID on the card.

✍ Notes

- When you see an asterisk on the display, the ID number has been used for other data or a macro. If you select the used ID number, the old data or macro is erased and replaced with the new data.
- Once the data is saved, you can execute it with "EXECUTE DATA" or with a data execution command.
- The data saved in the SAVE DATA mode can not be run with the macro execution command in HP LaserJet 4 emulation.

- Save Macro

Note

The “SAVE MACRO” menu appears only in the HP LaserJet 4 emulation mode.

If you have downloaded a macro in the printer’s memory, you can save the macro on the installed flash memory card or HDD card.

If a macro has been downloaded in the printer’s memory and you press the SET switch at “SAVE MACRO,” the printer prompts you to select the ID of the macro.

MACRO ID=#####

Select the ID with the ▲ or ▼ switch and press the SET switch again, so that the printer saves the macro with the selected ID.

Note

When you see an asterisk on the display, the ID number has been used for another macro or data. If you select the used ID number, the old macro or data is erased and replaced with the new macro.

You can execute a macro with the macro execution command.

- Primary Font or Secondary Font

Note

The “PRIMARY FONT” and “SECONDARY FONT” menus appear only in the HP LaserJet 4 emulation mode.

If you have selected the primary or secondary font with the FONT switch, you can save the font on the installed flash memory card or HDD card.

When you press the SET switch at “PRIMARY FONT” or “SECONDARY FONT,” the printer prompts you to select the ID of the font.

FONT ID=#####

Select the ID with the ▲ or ▼ switch and press the SET switch again, so that the printer saves the font with the selected ID.

Note

When you see an asterisk on the display, the ID number has been used for another font. If you select the used ID number, the old font is erased and replaced with the new one.

Whatever font you have selected with the FONT switch, the printer saves the font as a bitmapped font as long as the print size is no more than 24 points, so that the printer can print it faster than when they are not saved. It is recommended that you save the scalable font you frequently use for faster printing.

Since the flash memory card or the HDD card is in the upper card slot A of the printer and fonts stored in the card behave in the same way as they would if they were in a dedicated Font Card, you can select the saved fonts as "SLOTFONT A" with the FONT switch or the font selection command from your software. For font selection, see "FONT Switch" in Chapter 4.

You can check the saved fonts by printing the list of fonts with the TEST switch. See "TEST Switch" in Chapter 4.

Notes

When you save the primary or secondary font, note the following:

- The font is temporarily stored in the RAM of the printer before it is saved on the card. If the font data exceeds the RAM capacity, a memory full error occurs. You can clear this error with the CONTINUE switch. As not all the font data has been stored in RAM, you cannot save the font to the card. When the font data is saved, the printer is reset to ensure as much capacity as possible in RAM. If any data remains, it is printed out.
- If you have saved the font at 600-dpi resolution and change the printer resolution to 300 dpi, the printer cannot print the saved font.

- Download Font

 **Notes**

- The “DOWNLOAD FONT” menu appears only in the HP LaserJet 4 emulation mode.
- Be sure to print out the list of download fonts with the TEST switch and check the download font ID on the list before you enter this menu. You need to select the font in this menu with the same number you see on the list.

If you have downloaded a font into the printer memory, you can save it on the flash memory card or the HDD card.

The printer prompts you to select the download font ID that you can find from the font list. Press the SET switch to move the cursor to the ID and select it with the ▲ or ▼ switch.

FONT ID=#####

 **Note**

The download font IDs do not appear when fonts have not been downloaded.

After you select the download font ID, press the SET switch, so that the printer saves the selected download font. Vector or bitmapped fonts are saved in the format of the original font.

Once you save the download font in the card, you do not need to download the font every time you need it.

Since the flash memory card or the HDD card is in the upper card slot A of the printer, you can select the saved fonts as “SLOTFONT A” with the FONT switch or the font selection command from your software. For font selection, see “FONT Switch” in Chapter 4.

You can check the fonts saved on the card by printing the list of fonts with the TEST switch. See “TEST Switch” in Chapter 4.

 **Note**

When the fonts on the HDD card are selected in a print job, they are copied into the printer RAM. It may tend to cause the printer memory full error because those fonts occupy some RAM space. It is recommended to install optional SIMM to use the downloaded fonts on the HDD card.

■ Delete

When you select “DELETE” and press the SET switch, you can enter the following sub-setting menus to delete macros and fonts or format the installed flash memory card or HDD card:

Display Message	Save Menu
MACRO ID=#####	Delete the selected ID macro.
DATA ID=#####	Delete the selected ID data.
FONT ID=#####	Delete the selected ID font.
FORMAT CARD	Format the flash memory card or the HDD card.

• Macro

When you press the SET switch at “MACRO ID=#####,” the cursor moves to the ID number. The printer prompts you to select the ID number of the macro to be deleted.

MACRO ID=#####

Select the ID number with the ▲ or ▼ switch and press the SET switch, so that the printer deletes the selected macro.

• Data

When you press the SET switch at “DATA ID=#####,” the cursor moves to the ID number. The printer prompts you to select the ID number of the data to be deleted.

DATA ID=#####

Select the ID number with the ▲ or ▼ switch and press the SET switch, so that the printer deletes the selected data.

• Font

When you press the SET switch at “FONT ID=#####,” the cursor moves to the ID number. The printer prompts you to select the ID number of the font to be deleted.

```
FONT ID=#####
```

Select the ID number with the ▲ or ▼ switch and press the SET switch, so that the printer deletes the selected font.

- Format Card

You can format the flash memory card or the HDD card to delete its contents. Instructions are in the following menu:

```
FORMAT CARD
```

When you press the SET switch in this menu, the printer asks if you delete all contents of the card:

```
SET-->DELETE ALL
```

Press the SET switch to start formatting the card.

When you want to cancel formatting, move to the following menu with the ▲ or ▼ switch and press the SET switch.

```
exit
```

ADVANCED MODE

NETWORK MODE

Display Message	Network Mode
LOCK PANEL=OFF	Turns on or off lock panel function.
AUTO FF=ON	Turns on or off auto form feed.
FF SUPPRESS=OFF	Turns on or off the form feed suppress function.
TONER LOW=CONT	Select the printer's action when "TONER EMPTY" is detected

■ Lock panel

If someone other than you has changed the panel switch settings and you do not know about it, the printer may not print as you expected or it may not print at all.

To cope with this problem, you can lock or unlock the panel switches with your pass number as follows:

Display Message	Lock Panel
LOCK=OFF	Unlock the panel switches of the printer. (Factory setting)
LOCK=ON	Lock the panel switches of the printer.

Even if you lock the panel switches, you can use the SEL, FORM FEED, COPY, CONTINUE, RESET and TEST switches. You can only check the settings of the other switches, but you cannot change them. To change them, unlock the panel switches.

When you lock or unlock the panel switches as above, you need to enter a 3-digit pass number.

PASS NO=***

Change the number with the ▲ or ▼ switch and move to the next digit with the SET switch. After you finish entering your 3-digit pass number, the panel switches are locked or unlocked.

✍ Note
Do not forget your pass number that you have used to lock the panel switches. If you enter a wrong number, you cannot unlock them. The display shows the following message:

INCORRECT!!

■ Auto Form Feed

If unprinted data remains in the printer's memory, the DATA lamp stays on. You need to print out the remaining data with the FORM FEED switch. See "FORM FEED Switch" in Chapter 4.

The auto form feed you can set in this mode menu allows you to print out the remaining data without pressing the FORM FEED switch.

You can turn on or off the auto form feed in this mode menu as follows:

Display Message	Auto Form Feed
AUTO FF=OFF	Turn off the auto form feed. You need to press the FORM FEED switch every time data remains in the printer's memory. (Factory setting)
AUTO FF=ON	Turn on the auto form feed. Every time data remains in the printer's memory, the auto form feed takes place after the wait time set as below.

When you turn on the auto form feed as above, you need to set the wait time in the following sub-setting menu:

Display Message	Wait Time
WAIT TIME= 1s	Set the wait time for the auto form feed. The printer automatically prints out the remaining data after the set wait time.
·	
·	The wait time can be set from 1 to 99 seconds.
WAIT TIME=99s	

■ Form Feed Suppress

You can turn on or off the form feed suppress function in this mode menu as follows:

Display Message	Form Feed Suppress
FF SUPPRESS=OFF	Turn off the form feed suppress function. (Factory setting)
FF SUPPRESS=ON	Turn on the form feed suppress function.

If pages contain no print data, the printer would normally print blank pages. When you turn this function on, you can suppress printing blank pages.

When the printer is used in the network environment, it may print a blank page at the end of each print job. When you turn on this function, the printer does not print blank pages.

■ Toner Low

You can select the printer's action when "TONER EMPTY" is detected.

Display Message	Network Mode
TONER LOW=CONT	Continue printing if the "TONER EMPTY" error occurs. (Factory setting)
TONER LOW=STOP	Stop printing if the "TONER EMPTY" error occurs.

CONTINUE MODE

If any recoverable error occurs including "Toner Empty," it can be cleared with the CONTINUE switch. The CONTINUE switch function is selected with this mode setting.

Display Message	Continue Mode
CONTINUE=MANUAL	Select the manual or auto error recovery mode. Press the CONTINUE switch to clear errors. (Factory setting)
CONTINUE=AUTO	Select the auto error recovery mode. The printer automatically clears recoverable errors. You need not press the CONTINUE switch.

PRINT DENSITY

You can increase or decrease the print density with the ▲ or ▼ switch in this mode menu as follows:

Display Message	Print Density
■■■■■■■■■■■■■■■■■■■■ ■■■■■■■■■■■■■■■■■■■■ : ■■ ■	The more black squares, the darker the print density. The black squares indicate the density level. The density can be set to 15 levels. (Factory setting = ■■■■■■■■)

INPUT BUFFER

You can increase or decrease the capacity of the input buffer with the ▲ or ▼ switch in this mode menu. A larger capacity allows the printer to receive data from the computer faster.

Display Message	Input Buffer
□□□□□□□□□□□□□□□□ □□□□□□□□□□□□□□□□ : : □□ □	The more squares, the larger the capacity of the input buffer. The squares indicate the level of the capacity but not the size in Mbytes. The capacity can be set 15 levels. (Factory setting = □□□□□)

After you change the input buffer capacity (make sure you press SET switch), be sure to turn off the printer and then turn it on again. The setting takes effect the next time you turn on the printer.

Notes

- The set capacity is not changed even if the emulation mode is changed.
- The actual capacity of the input buffer varies according to the installed RAM. If the RAM capacity is small, the input buffer capacity may not be increased.
- When you select duplex printing, it requires more memory to run duplex printing. If you set a large input buffer and the remaining memory is not enough to run duplex printing, the print speed may decrease in duplex printing, the 600dpi resolution may decrease to 300dpi, or the printer may automatically change duplex printing to simplex printing. In such a case, you need to install optional SIMM memory or set a smaller input buffer size in this mode.

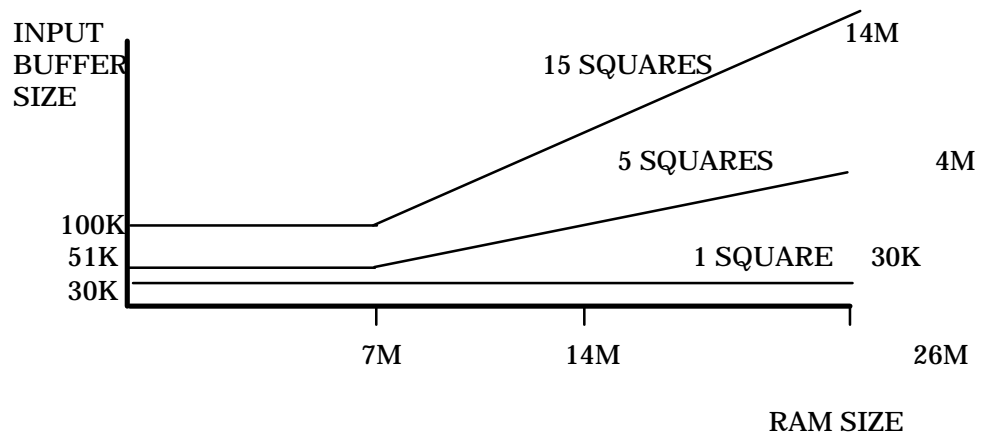

Fig. 4-5 Input buffer size

SAVE SETTINGS

Suppose you share this printer with others who want different panel switch settings or you use the printer with different settings.

Since you can save the current settings in the printer's memory, you can easily reset the printer to your necessary settings after they are changed. For resetting the printer, see "RESET Switch" in Chapter 4.

Use the panel switches to set the configuration of the printer to your needs and then enter this mode menu to save your settings. Two sets of user settings can be saved in the printer as follows:

Display Message	User Setting
SAVE SETTING 1	Save the current settings as No. 1 in the printer's memory.
SAVE SETTING 2	Save the current settings as No. 2 in the printer's memory.

If you want to check the user settings, you can print out a list of the settings with the TEST switch. See "TEST Switch" in Chapter 4.

Note
No user settings have been factory set.

PAGE COUNTER

You can check the total number of printed pages with this mode. When you enter this mode, the display shows the number for a short time and automatically moves to “exit MODE” menu.

```
COUNT= 861
```

EXIT MODE

When you finish setting your desired item in the mode menus, advance to the following message:

```
exit MODE
```

Press the SET switch to exit from the mode menus to the off-line ready state.

 Note

Remember that you can exit from the mode menu any time with the SEL switch. After you make a setting effective with the SET switch, press the SEL switch. You will exit from the mode menu to the on-line ready state. The settings you have changed with the SET switch are effective after a quick exit.

FONT Switch

Pressing the FONT switch allows you to select fonts and symbol/character sets.

Notes

When you use the FONT switch, note the following:

- The FONT switch is effective in the HP LaserJet 4, EPSON FX-850, and IBM Proprinter XL modes. However the settings are subject to the current emulation mode.
- If the application software supports font and symbol/character set selection, you do not need to set them with the FONT switch. The software or command setting overrides the switch setting.
- If you want to use optional fonts other than the printer's resident fonts, be sure to install a font cartridge/card that has your desired fonts. The printer automatically selects the font that has exactly the same or similar characteristics as those you set through the software or with a command. If the installed font cartridge/card happens to have a font of similar characteristics, the printer will print with an unexpected font.
- You can store the fonts you require on a flash memory card or a HDD card only in the HP LaserJet 4 mode when one is installed. See "CARD OPERATION."

Setting the Font and Symbol Set in the HP LaserJet 4 Mode

When the HP LaserJet 4 emulation mode has been selected, the font and symbol set can be set separately as the primary or secondary font.

The display shows the following setting menus:

PRIMARY FONT	SELECT FONT p	Set the primary font.
	SYMBOL SET p	Set the symbol set.
	TABLE PRINT p	Print the code table.
	exit	Exit

SECONDARY FONT	SELECT FONT s	Set the secondary font.
	SYMBOL SET s	Set the symbol set.
	TABLE PRINT s	Print the code table.
	exit	Exit

To select the font and symbol set in the HP LaserJet 4 mode, follow these steps:

1. Press the SEL switch to set the printer off-line.
2. Press the FONT switch.

The display shows the following menu.

PRIMARY FONT

3. Press the ▲ or ▼ switch to select the primary or secondary font setting menu.

PRIMARY FONT

SECONDARY FONT

For this session, select the primary font setting menu.

4. Press the SET switch.

The display shows the font setting menu. You can skip the font setting menu and advance to the symbol set setting menu with the ▲ or ▼ switch. For this session, go to the next step.

SELECT FONT p

Note

The last lowercase letter “p” or “s” indicates the primary or secondary font setting mode. If you select the secondary font setting mode, the display shows “s” in the following messages.

5. Press the SET switch.

When you enter the "SELECT FONT" menu, you can select the internal font, optional slot font, or permanent download font. The display shows the following message.

INTERNAL FONT p*

Press the ▲ or ▼ switch until the desired font source appears on the display.

Display Message	Font Source
INTERNAL FONT	Internal font of the printer
SLOTFONT A	Optional card font in the upper slot A
SLOTFONT B	Optional cartridge font in the lower slot B
PERMANENT FONT	Permanent download font defined in the HP emulation mode

Since these steps instruct you to select the standard font, select the "INTERNAL FONT" message.

Notes

When you select the optional fonts or permanent download fonts, note the following:

- If the optional font cartridge/card is not installed, the optional font cannot be selected. No selection appears on the display.
- If permanent fonts are not downloaded in the HP emulation mode or another emulation mode is selected, they cannot be selected. No selection appears on the display.
- The list you can print out with the TEST switch helps you to select the optional fonts or permanent download fonts. See "TEST switch" in this chapter or "Selecting the Optional Fonts" in Chapter 5.

6. Press the SET switch.

When you enter the font setting mode, the display first shows the current font with an asterisk.

BROUGHAM p*

7. Press the ▲ or ▼ switch until the desired font appears on the display.

See “List of Fonts” on page 4-54.

8. Press the SET switch to make the displayed selection effective.

The steps you follow vary according to the font type, scalable or bitmapped.

- If you select a resident bitmapped font (Letter Gothic 16.66) or optional bitmapped fonts, the display shows the symbol set setting menu.

SYMBOL SET	p
------------	---

Go to step 9.

- If you select resident scalable fonts or optional scalable fonts, the display shows the font style setting menu.

BROUGHAM	p
----------	---

↓ The display changes to the font style menu.

BROUGHAM Reg	p*
--------------	----

Press the ▲ or ▼ switch until the desired style appears on the display.

Display Message	Font Style
..... Lt	Light
..... Reg	Regular, Roman, Book, or Antique
..... Bd	Bold or Demi
..... Xb	Extrabold
..... It	Italic or Oblique

Note
 The style indication appears after the font name and the style name differs according to the font name. The italic or oblique indication can appear after other style indication: “BdIt” indicates a bold italic font, “LtIt” indicates a light italic font, etc.

Press the SET switch to make the displayed selection effective, then the display shows the font size setting menu.

Note

When you have selected fixed-pitch fonts, you set the font size by the character pitch (width). When you have selected proportional spacing fonts, you set the font size in points (height). The display shows "PITCH" or "POINT" accordingly. The following displays show "PITCH" to simplify instructions.

PITCH= 10.00 *

Press the ▲ or ▼ switch until the desired font size appears on the display.

Press the SET switch to make the displayed selection effective. The blinking cursor then moves to the decimal part of the number.

Press the ▲ or ▼ switch until the desired decimal number appears on the display.

PITCH= 16.66

Press the SET switch to make the displayed selection effective. The display then shows the symbol set setting menu.

SYMBOL SET p

9. Press the SET switch.

When you enter the symbol set setting mode, the display first shows the current symbol set with an asterisk.

ROMAN 8 p*

10. Press the ▲ or ▼ switch until the desired symbol set appears on the display.

See "List of Symbol/Character Sets" on page 4-55.

11. Press the SET switch to make the displayed selection effective.

The display then shows the next menu.

TABLE PRINT	p
-------------	---

12. Press the SET switch to start printing the code table of the selected font, or press the ▲ or ▼ switch to skip this menu.

The display shows the exit menu.

exit

13. Press the SET switch to exit from the setting mode.

The printer returns to the off-line state.

Setting the Font and Character Set in the, EPSON FX-850, or IBM Proprinter XL Mode

When the EPSON FX-850 or IBM Proprinter XL mode has been selected, the font and character set can be selected.

The display shows the following setting menus.

SELECT FONT	Select the font.
CHARACTER SET	Select the character set.
TABLE PRINT	Print the code table.
exit	Exit

To select the font and character set in the EPSON FX-850 or IBM Proprinter XL mode, follow these steps:

1. Press the SEL switch to set the printer off-line.
2. Press the FONT switch.

The display shows the font setting menu. You can skip the font setting menu and advance to the character set setting menu with the ▲ or ▼ switch. For this session, go to the next step.

SELECT FONT

3. Press the SET switch.

When you enter the "SELECT FONT" menu, you can select the internal font, optional slot font, or permanent download font. The display shows the following message.

INTERNAL FONT *

Press the ▲ or ▼ switch until the desired font source appears on the display.

Display Message	Font Source
INTERNAL FONT	Internal font of the printer
SLOTFONT A	Optional card font in the upper slot A
SLOTFONT B	Optional cartridge font in the lower slot B
PERMANENT FONT	Permanent download font defined in the HP emulation mode

Since these steps instruct you to select the standard font, select the "INTERNAL FONT" message.

Notes

When you select the optional fonts or permanent download fonts, note the following:

- If the optional font cartridge/card is not installed, the optional font cannot be selected. No selection appears on the display.
- If permanent fonts are not downloaded in the HP emulation mode or another emulation mode is selected, the permanent fonts cannot be selected. No selection appears on the display.
- When you select the optional font or download font, press the SET switch to enter the sub-menu. After you select your desired one with the ▲ or ▼ switch, press the SET switch again. The list you can print out with the TEST switch helps you to select the optional fonts or permanent download fonts. See "TEST switch" in this chapter or "Selecting the Optional Fonts" in Chapter 5.

4. Press the SET switch.

When you enter the font setting mode, the display first shows the current font with an asterisk.

BROUGHAM *

5. Press the ▲ or ▼ switch until the desired font appears on the display.

See “List of Fonts” on page 4-54.

6. Press the SET switch to make the displayed selection effective.

The steps you follow vary according to the font type, scalable or bitmapped.

- If you select a resident bitmapped font (Letter Gothic 16.66) or optional bitmapped fonts, the display shows the character set setting menu.

CHARACTER SET

Go to step 7.

- If you select the resident scalable fonts or optional scalable fonts, the display shows the font style setting menu.

BROUGHAM

↓ The display changes to the font style menu.

BROUGHAM Reg *

Press the ▲ or ▼ switch until the desired style appears on the display.

Display Message	Font Style
..... Lt	Light
..... Reg	Regular, Roman, Book, or Antique
..... Bd	Bold or Demi
..... Xb	Extrabold
..... It	Italic or Oblique

Note

The style indication appears after the font name and the style name differs according to the font name. The italic or oblique indication can appear after any style indication: "BdIt" indicates a bold italic font, "LtIt" indicates a light italic font, etc.

Press the SET switch to make the displayed selection effective, then the display shows the font size setting menu.

Note

When you have selected fixed-pitch fonts, you set the font size by the character pitch (width). When you have selected proportional spacing fonts, you set the font size in points (height). The display shows "PITCH" or "POINT" accordingly. The following displays show "PITCH" to simplify instructions.

PITCH= 10.00 *

Press the ▲ or ▼ switch until the desired font size appears on the display.

Press the SET switch to make the displayed selection effective. Then the blinking cursor moves to the decimal part of the number.

Press the ▲ or ▼ switch until the desired decimal number appears on the display.

PITCH= 16.66

Press the SET switch to make the displayed selection effective. The display then shows the character set setting menu.

CHARACTER SET

7. Press the SET switch.

When you enter the character set setting mode, the display first shows the current character set with an asterisk.

US ASCII	*
----------	---

Note

The character set varies according to the current emulation mode. The above display shows the factory setting in the EPSON FX-850 emulation mode.

8. Press the ▲ or ▼ switch until the desired character set appears on the display.

See “List of Symbol/Character Sets” on page 4-55.

9. Press the SET switch to make the displayed selection effective.

Then the display shows the next menu.

TABLE PRINT

10. Press the SET switch to start printing the code table of the selected font, or press the ▲ or ▼ switch to skip this menu.

Then the display shows the exit menu.

exit

11. Press the SET switch to exit from the setting mode.

The printer returns to the off-line state.

List of Fonts

For specific characters in resident bitmapped and scalable fonts.

Display Message	Font
BROUGHAM	Scalable Brougham
OCR-B	Bitmapped OCR-B 12 cpi
LETTERGOTH16.6	Bitmapped Letter Gothic 16.66 cpi
PcTENNESSEE	Scalable PC Tennessee
CONNECTICUT	Scalable Connecticut
CLEVELAND Cd	Scalable Cleveland Condensed
UTAH	Scalable Utah
GUATEMALA	Scalable Guatemala Antique
MARYLAND	Scalable Maryland

List of Symbol/Character Sets

The symbol sets and character sets are subject to the current emulation mode. For specific symbol/character sets, see “SYMBOL/CHARACTER SETS” in Appendix.

HP LaserJet 4	EPSON	IBM
ROMAN 8 *	US ASCII *	PC-8 *
ISO LATIN1	GERMAN	PC-8 D/N
ISO LATIN2	UK ASCII I	PC-850
ISO LATIN5	FRENCH I	PC-852
PC-8	DANISH I	PC-860
PC-8 D/N	ITALY	PC-863
PC-850	SPANISH	PC-865
PC-852	SWEDISH	PC-8 TURKISH
PC-8 TURKISH	JAPANESE	
WINDOWS LATIN1	NORWEGIAN	
WINDOWS LATIN2	DANISH II	
WINDOWS LATIN5	UK ASCII II	
LEGAL	FRENCH II	
ISO 2 IRV	DUTCH	
ISO 4 UK	SOUTH AFRICAN	
ISO 6 ASCII	PC-8	
ISO10 SWE/FIN	PC-8 D/N	
ISO11 SWEDISH	PC-850	
ISO14 JISASCII	PC-852	
ISO15 ITALIAN	PC-860	
ISO16 POR	PC-863	
ISO17 SPANISH	PC-865	
ISO21 GERMAN	PC-8 TURKISH	
ISO25 FRENCH		
ISO57 CHINESE		
ISO60 NOR v1		
ISO61 NOR v2		
ISO69 FRENCH		
ISO84 POR		
ISO85 SPANISH		
HP GERMAN		
HP SPANISH		
VENTURA MATH		
VENTURA INTL		
VENTURA US		
PS MATH		
PS TEXT		
MATH-8		
PI FONT		
MS PUBLISHING		
WINDOWS 3.0		
MC TEXT		
DESKTOP		

 **Note**

The factory settings are indicated by an asterisk “ * ” in the table above.

FORM FEED Switch (REPRINT Switch)

The FORM FEED switch works in two ways according to the DATA lamp status.

Form Feed

When the printer is off-line and there is data remaining in the printer memory, the DATA lamp comes on. Pressing the FORM FEED switch executes a form feed and prints out the remaining data. The display may look as follows:

```
01 PRINT 001P T1
```

If you set the number of copies with the COPY switch and press the FORM FEED switch during copy printing, the printer suspends the form feed operation and the display shows the following message:

```
07 FF PAUSE
```

Pressing the SEL switch again resumes the form feed operation.

When no data remains in the printer memory and you press the FORM FEED switch, the printer ignores this switch operation and the display shows the following message:

```
No Data !!!
```

Note

If you want the printer to print out the remaining data automatically, you can set the auto form feed function with the MODE switch. See "AUTO FORMFEED" in Chapter 4.

Reprint Function

You can reprint the same page of data without sending it from the computer again. When you press the FORM FEED switch with the DATA lamp off, the printer reprints the same page. You can use this function in order to recover printing when a paper jam has occurred.

After printing is finished, set the printer off-line and press the FORM FEED switch once, so that the printer prints the last page of data.

When you press the FORM FEED switch one or more times during reprinting, you can set the number of pages to reprint. The printer reprints the same page the number of times you press the switch.

 **Note**

The reprint data remains in the printer's memory until the printer is reset or the emulation, or some settings are changed. After you have reprinted confidential data, be sure to reset the printer to clear it from the printer's memory.

CONTINUE Switch

If there is a problem with the printer, it automatically suspends printing and goes off-line. Pressing the CONTINUE switch may ignore the error and resume printer operation.

The function of this switch varies according to the CONTINUE mode set with the MODE switch.

Since the CONTINUE mode has been factory set to MANUAL, you need to press the CONTINUE switch to recover from a printer error message. If you set the mode to AUTO, the printer attempts to resume the operation without pressing the CONTINUE switch.

For further information, see "CONTINUE MODE" in Chapter 4.

 Note

The CONTINUE switch is not a cure-all. The printer cannot recover from some errors. Take corrective action, referring to the error message. See "TROUBLESHOOTING" in Chapter 7.

SWITCHES IN SHIFT MODE

You can control the basic printer operations and make various printer settings also in the SHIFT mode. Functions available in the SHIFT mode are labeled with the indications just below the panel switches.

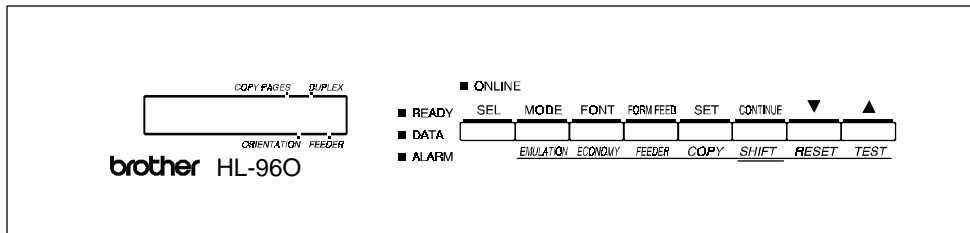

Fig. 4-6

Switches in SHIFT Mode

Note

The factory settings are printed in bold in this section.

SHIFT Switch

When you hold the SHIFT switch down with the printer off-line, you can change settings with the panel switches in the SHIFT mode. Since the shift state is not locked, you need to hold it down and press the switch to get access to the corresponding shifted function labeled under the switch.

EMULATION Switch

This printer has been factory set with the automatic emulation selection function on. The printer can select the emulation mode automatically when it receives data from the computer.

When you want to set the emulation mode manually, hold down the SHIFT switch and press the EMULATION switch. Then you enter the setting mode where you change the emulation.

To set the emulation mode, follow these steps:

1. Press the SEL switch to set the printer off-line.
2. Hold down the SHIFT switch and press the EMULATION switch.

When you enter the setting mode, the display first shows the current emulation mode with an asterisk.

AUTO	*
------	---

3. Press the ▲ or ▼ switch until the desired emulation mode appears on the display.

Display Message	Emulation Mode
HP LaserJet 4	HP LaserJet 4
HP-GL	HP-GL Plotter Mode
EPSON FX-850	EPSON FX-850
IBMProprinterXL	IBM Proprinter XL
AUTO	Auto Emulation Selection

4. Press the SET switch to make the displayed selection effective.

When you select any specific emulation mode other than "AUTO," an asterisk appears at the end of the display for a short time. Then the printer automatically exits from the setting mode to the off-line state.

When you select "AUTO," the sub-item "Time Out" for the automatic emulation selection appears on the display. Go to the next step.

5. Set “Time Out” with the ▲ or ▼ switch.

TIME OUT= 5s *

This time out is the duration during which the printer will not allow an automatic emulation change. You can set it to 1 second from 99 seconds: **the factory setting is 5 seconds.**

6. Press the SET switch.

The next sub-item “EPSON/IBM” appears on the display.

EPSON/IBM=EPSON*

7. Select EPSON or IBM with the ▲ or ▼ switch.

Since the printer cannot distinguish between the EPSON and IBM emulation modes, you need to select the EPSON or IBM emulation even in the AUTO mode.

When the printer receives data from the computer, it automatically selects the emulation mode in any of the following combinations:

EPSON/IBM Priority	EPSON	IBM
Auto Selection Mode	HP LaserJet 4	HP LaserJet 4
	HP-GL	HP-GL
	EPSON FX-850	IBM Proprinter XL

8. Press the SET switch.

The next sub-item “KEEP PCL” appears on the display.

KEEP PCL=OFF

This function is for permanent macros and fonts downloaded in the HP LaserJet 4 mode.

9. Turn on or off the “KEEP PCL” function with the ▲ or ▼ switch.

When you do not need to use the permanent macros and fonts in the HP LaserJet 4 mode, turn this function off. When you use them, you can turn it on.

If the function is turned on, the downloaded macros and fonts are kept in the printer's memory until the printer is turned off, so that they are not cleared by switching to the other emulations.

Note

The "KEEP PCL" function reserves free space in the printer's memory and may cause a memory full error. If a memory full error occurs, expand the memory capacity or turn off this function.

10. Press the SET switch.

The "exit" message appears on the display.

11. Press the SET switch again.

The printer exits from the setting mode to the off-line state.

Note

When you use the automatic emulation selection, try it with your application software or network server. If the function does not work properly, select a particular emulation mode manually. You can use the following commands to select the emulation on the network.

Commands	Hex	Emulation
ESC CR H	1B 0D 48	HP LaserJet 4
ESC CR GL	1B 0D 47 4C	HP-GL
ESC CR E	1B 0D 45	EPSON FX-850
ESC CR I	1B 0D 49	IBM Proprinter XL

About Emulation Modes

This printer has the following emulation modes:

■ HP LaserJet 4 Mode

The HP LaserJet 4 mode (or HP mode) is the emulation mode where this printer emulates the Hewlett-Packard LaserJet 4 laser printer. Since a large number of application software packages support this type of laser printer, your printer will operate at its optimum performance in this mode.

■ **HP-GL Mode**

The HP-GL mode is the emulation mode where this printer emulates the Hewlett-Packard plotter model HP-7475A. Since many graphics and CAD applications support this type of plotter, you can get more out of this printer working with your application software.

■ **EPSON FX-850 and IBM Proprinter XL Mode**

The EPSON FX-850 and IBM Proprinter XL modes are the emulation modes where this printer emulates the industry-standard dot matrix printers of respective manufacturers. Since most applications support these printers, you do not have to be concerned about compatibility.

ECONOMY Switch

POWER SAVE MODE

You can turn on or off the power save mode as follows:

Display Message	Power Save Mode
POWER SAVE=ON	Turn on the power save mode. The fixing assembly of the print engine is turned off after the specified time to save power. (Factory setting)
POWER SAVE=OFF	Turn off the power save mode. The fixing assembly of the print engine is always powered on to keep its temperature at the specified level.

When you turn on the power save mode with the SET switch, the display shows the next sub-setting menu as follows:

TIME OUT=30m *

You need to set the time out for the power save mode from 1 to 99 minutes with the ▲ or ▼ switch: **factory setting =30 minutes**. The time out is the duration after which the fixing assembly of the print engine is turned off ("SLEEP") to save power.

When the power save mode is turned on, the printer turns on the fixing assembly again after it receives data from the computer. Since the fixing assembly must reach the specified high temperature, it takes a little longer time to start printing the first page.

FEEDER Switch

You can select the feeder, manual feed mode, or MP tray settings with the FEEDER switch, and also select the duplex printing mode if the optional duplex printing unit is installed.

Display Message	Feeder
FEEDER=AUTO	Select a feeder or auto paper feed .
MP FIRST=OFF	Turns MP first on or off .
MANUAL FEED=OFF	Turns manual feed on or off .
MP TRAY SETTING	MP tray settings
MEDIA TYPE	Select print media
DUPLEX MODE	Selects duplex printing mode (only with the duplex option installed.)

You can check the current feeder and the duplex mode on the display.

When tray 1 has been selected, the display may look as follows:

```
00 READY 001P T1
```

When the multi-purpose tray and the duplex printing mode have been selected, the display may look as follows:

```
00 READY 001P■MP
```

The black square ■ indicates that duplex printing mode is selected.

When you want to change settings with the FEEDER switch, hold down the SHIFT switch and press the FEEDER switch. You will then enter the setting mode where you change the feeder, manual feed mode, etc.

FEEDER

To select the feeder, follow these steps:

1. Press the SEL switch to set the printer off-line.
2. Hold down the SHIFT switch and press the FEEDER switch.

When you enter the setting mode, the display first shows the current feeder setting with the asterisk.

FEEDER=AUTO *

3. Press the ▲ or ▼ switch until the desired feeder appears on the display.

Display Message	Paper Feed Method/Paper Source
FEEDER=AUTO	Auto paper feed
FEEDER=MP TRAY	Cassette feed from multi-purpose tray (MP tray)
FEEDER=TRAY1	Upper paper cassette (Tray 1)
FEEDER=TRAY2	Lower paper cassette (Tray 2)

Notes

When you select a feeder, note the following:

- The “FEEDER=TRAY2” message appears only when the optional lower tray unit has been installed.
- The FEEDER=AUTO setting allows you to optimize your printing environment. This setting allows a print job to continue uninterrupted when a paper out condition occurs. The default setting is AUTO. This setting allows a common printing situation: Loading the same size and type of paper in all paper trays. This allows your print job to continue without error if one of the paper trays becomes empty. The printer will automatically select another tray if one tray becomes empty.
- When you select the FEEDER=AUTO, the printer automatically searches for the paper size you set with the MODE switch in the PAGE FORMAT mode and loads the paper from the paper source that contains the selected size of paper. If all of the upper and lower paper cassettes and the multi-purpose tray contain the different size of paper and one paper cassette runs out of paper, the printer stops printing without automatically changing to the other paper source to feed paper. It prevents different size of paper from being printed by mistake.
- If you have the same size of paper loaded but of different type (i.e.: FORM “A” in Tray 1, FORM “B” in Multi-purpose Tray) it is recommended to change the feeder setting from AUTO to Tray 1. This setting will allow the printer to pause when a paper empty condition occurs, allowing you to load the correct type of paper, then press SEL to finish to print job.

4. Press the SET switch to make the displayed selection effective.

When you select “MP TRAY”, “TRAY1,” or “TRAY2,” an asterisk appears at the end of the display for a short time. Then the “exit” message appears on the display. Press the SET switch again, so that the printer exits from the setting mode to the off-line state.

When you select “AUTO”, the tray selection menu for the auto paper feed appears on the display. Go to the next step.

5. Change the tray combination and priority with the ▲ or ▼ switch. For example:

AUTO=T1>MP	*
------------	---

When “AUTO=T1>MP” is set, both the tray 1 and the multi-purpose tray are selected but first tray 1 will be selected if the paper size in tray 1 and the page size for the printing job match each other.

6. Press the SET switch.

MP FIRST

The display shows the current setting for the MP FIRST mode for the multi-purpose tray with an asterisk.

MP FIRST=OFF	*
--------------	---

1. Press the ▲ or ▼ switch to select on or off for the MP FIRST mode in the multi-purpose tray.

Notes

- When you want to print the first page on paper such as letterhead in the multi-purpose tray, and the following pages on the paper such as plain paper in another tray, place a sheet for the first page on the multi-purpose tray and select the “MP FIRST=ON” in this menu. Then the printer first selects the multi-purpose tray regardless of the “FEEDER=####” setting and then automatically switches to the feeder selected in the “FEEDER=####” menu after the multi-purpose tray becomes empty.
- You can use the MP tray as a convenient temporary feeder by setting MP FIRST=ON. When MP FIRST=ON is set, if you place paper on MP tray, this paper will be printed, and if you do not place paper on MP tray, another tray will be selected according to the command or the “FEEDER=####” setting.

- You can set “MP FIRST=ON” so that you can use the MP tray paper first until it becomes empty and then switch to other paper sources which hold the same size of paper. You can set “MP FIRST=ON” for this purpose only when all the trays hold the same type and size of paper. When the MP tray paper size is different from paper in other trays, you must not select “ON” if you do not want to use MP tray paper.

2. Press the SET switch.

MANUAL FEED

The display shows manual feed mode with an asterisk as follows:

MANUAL FEED=OFF*

1. Press the ▲ or ▼ switch to turn the manual feed mode on or off.
2. Press the SET switch to make the setting effective.

Note

When you select the “MANUAL FEED=ON”, note that the feeder set in the “FEEDER=####” menu is ignored and the manual feed mode from the multi-purpose tray is selected. You must set “MANUAL FEED=OFF” so that the feeder selection in the “FEEDER=####” menu can be effective.

MP TRAY SETTING

1. The display then shows the MP tray setting menu. Press the SET switch to enter this menu.

Then the display shows the current paper size setting for the multi-purpose tray with an asterisk.

MP SIZE=LETTER *

2. Press the ▲ or ▼ switch to select the paper size in the multi-purpose tray.

Note

When you select the multi-purpose tray as a paper source, you must set the "MP SIZE" manually since the tray can not sense the size automatically.

3. Press the SET switch to make the displayed setting effective.

Then the display shows the current "PAPER IN" setting with the asterisk as follows:

PAPER IN=CONT *

4. Press the ▲ or ▼ switch to select the printer action to continue or stop against the manual feed.

Note

You can select the printer action either to continue or to stop printing when you select the manual feed with this switch or by a command. When you set "PAPER IN=CONTINUE", the printer feeds paper from the multi-purpose tray. When you set "PAPER IN=STOP", the printer stops feeding paper until the SEL key is pressed. If you want to place the paper on the multi-purpose tray after you make a print request from the PC, select the "PAPER IN=STOP" so that the printer waits for the paper.

5. Press the SET switch to make the setting effective.

MEDIA TYPE

When you use any paper other than ordinary plain paper, such as thick bond paper, envelope, or transparency, the appropriate media type must be selected in the media type mode in order to get the best print quality.

To select a media type, follow these steps:

1. The display shows the following message:

MEDIA TYPE

2. Press the SET switch to enter the media type mode. The display then shows the current setting with an asterisk:

REGULAR *

3. Press the ▲ or ▼ switch to select regular, thick paper, or transparency.
4. Press the SET switch to make the setting effective.

✍ Notes

- Please do not forget to change the setting back after you print your special media with the setting changed.
- Envelopes can not be fed from the Tray 2 although you can set them in it.
- You must not load transparencies into tray 1 or tray 2. Please use the multi-purpose tray.

DUPLEX MODE

If the optional duplex printing unit has been installed, the duplex mode appears on the display as follows:

DUPLEX MODE

1. Press the SET switch to enter the duplex mode menu.

Then the display shows the current selection for the duplex printing or simplex printing (duplex off) with an asterisk as follows:

DUPLEX=OFF *

2. Press the ▲ or ▼ switch to select the duplex or simplex (duplex off), and press the SET switch.

When you set the “DUPLEX=ON”, the display shows the current bind setting with an asterisk as follows:

BIND=LONG *

3. Press the ▲ or ▼ switch to select long edge binding or short edge binding.

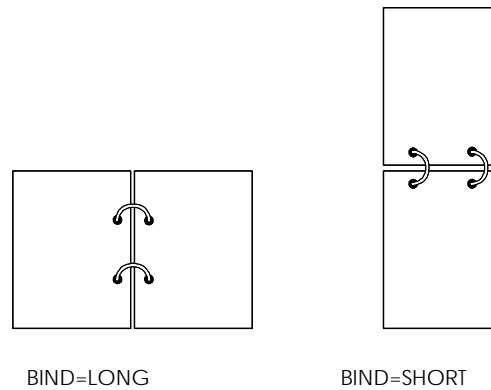

Fig. 4-7 Binding

4. Press the SET switch to exit the DUPLEX MODE.

The printer exits from the setting mode to the off-line state.

5. Press the SET switch again to exit the FEEDER switch setting mode to the printer off-line state.

Note

The duplex printing unit can handle letter, A4, legal, executive, and B5 sizes of paper. It can not handle a shorter size of paper than B5 (250mm-9.8 inches long).

COPY Switch

You can set the number of copies to print of the same page with the COPY switch. The computer will release from a printing job in a shorter time if you use this feature than when you set the copy print quantity with your application software. Check the current setting on the display.

When the number of copies has been set at 1, the display may look as follows:

```
00 READY 001P T1
```

When the number of copies has been set at 3, the display may look as follows:

```
00 READY 003P T1
```

Note
If you send too many pages to be stored in the printer memory, part or all the set pages or copies may not be printed.

To set the number of copies, follow these steps:

1. Press the SEL switch to set the printer off-line.
2. Hold down the SHIFT switch and press the COPY switch.

When you enter the setting mode, the display first shows the current setting with the asterisk.

```
COPY PAGES= 1 *
```

3. Press the ▲ or ▼ switch until the desired number appears on the display.

Display Message	# of Copies to Print Same Pages
COPY PAGES= 1	1 page
COPY PAGES= 2	2 pages
...	...
COPY PAGES=999	999 pages (max.)

4. Press the SET switch to make the displayed selection effective.

An asterisk appears at the end of the display for a short time. Then the printer automatically exits from the setting mode to the off-line state.

RESET Switch

You can reset the printer with the RESET switch. The print data that the printer has already received from the computer is cleared and the printer settings are restored to the user settings or factory settings.

The temporary download fonts and macro settings you set with commands in the HP LaserJet 4 mode are also cleared.

When you want to reset the printer, hold down the SHIFT switch and press the RESET switch. You then enter the reset mode where you reset the printer.

To reset the printer, follow these steps:

1. Press the SEL switch to set the printer off-line.
2. Hold down the SHIFT switch and press the RESET switch.

When you enter the reset mode, the display shows the first reset mode item.

RESET PRINTER

3. Press the ▲ or ▼ switch until the desired reset mode appears on the display.

Display Message	Reset Mode
RESET PRINTER	Resets the printer and restores all printer settings—including command settings—to settings you have previously made with the panel switches.
RESET SETTING 1 RESET SETTING 2	Resets the printer and restores all printer settings—including command settings—to the selected number (1-2) of user settings you have previously made with the MODE switch.
FACTORY SETTINGS	Resets the printer and restores all printer settings—including command settings—to the factory settings. See “List of Factory Settings.”
exit	Exits from the reset mode. The printer is not reset.

4. Press the SET switch to make the displayed selection effective.

The printer is reset according to the selected reset mode.

When the "RESET PRINTER" mode has been selected, the printer is reset showing the message alternately as follows:

08 RESET TO	→	USER SETTINGS
-------------	---	---------------

When the "RESET SETTING 1-2" mode has been selected, the printer is reset showing the message alternately as follows (# indicates the selected number of saved settings):

08 RESET TO	→	SETTING #
-------------	---	-----------

When the "FACTORY SETTINGS" mode has been selected, the printer is reset showing the message alternately as follows:

09 RESET TO	→	FACTORY SETTINGS
-------------	---	------------------

Then the printer automatically exits from the reset mode to the on-line state.

List of Factory Settings

The following table shows the factory settings initially set before shipment.

Notes

- The settings are subject to the emulation mode. Effective modes are indicated in parentheses in the following table.
- The following settings cannot be restored to the factory settings with the RESET switch in the "FACTORY SETTINGS" mode: INTERFACE MODE, HRC SETTING, PAGE PROTECTION, SCALABLE FONT, LOCK PANEL, and PAGE COUNTER, and local language for display messages.
- The COPY setting is always restored to the factory setting when the printer is turned off and on again.
- The user settings are overwritten after resetting to setting 1 or 2.

Switch	Item	Sub-Item	Factory Setting
MODE			
	INTERFACE MODE	-	I/F=AUTO
		For AUTO mode	
		TIME OUT	TIME OUT= 5s
		For bi-directional PARALLEL interface	
		HIGH SPEED	HIGH SPEED=ON
		BI-DIR	BI-DIR=ON
		For RS-232C serial interface	
		Baud Rate	BaudRate= 9600
		Code Type	CodeType=8 bits
		Parity	Parity =NONE
		Stop Bit	Stop Bit= 1 bits
		Xon/Xoff	Xon/Xoff=ON
		DTR (ER)	DTR (ER)=ON
		Robust Xon	Robust Xon=OFF
	FORMAT MODE	ORIENTATION	ORI=PORTRAIT
		AUTO MODE (HP LaserJet4)	
		AUTO LF	OFF
		AUTO CR	OFF
		AUTO WRAP	OFF
		AUTO SKIP	ON
		AUTO MODE (EPSON)	
		AUTO LF	OFF
		AUTO CR	ON (No indication)
		AUTO WRAP	ON (No indication)
		AUTO MASK	OFF
		AUTO MODE (IBM)	
		AUTO LF	OFF
		AUTO CR	OFF
		AUTO WRAP	ON (No indication)
		AUTO MASK	OFF

Switch	Item	Sub-Item	Factory Setting
	MODE (continued)		
	FORMAT MODE (continued)		
		PAGE FORMAT MODE (HP LaserJet4, EPSON, & IBM)	
		PAPER	LETTER (For 110/120V model) A4 (For 220/240V model)
		LEFT M	0 (LETTER, PORTRAIT) 0 (LEGAL, PORTRAIT) 0 (A4, PORTRAIT) 0 (LETTER, LANDSCAPE) 0 (LEGAL, LANDSCAPE) 0 (A4, LANDSCAPE) 0 (A5, LANDSCAPE) 0 (A6, LANDSCAPE)
		RIGHT M	80 (LETTER, PORTRAIT) 80 (LEGAL, PORTRAIT) 78 (A4, PORTRAIT) 106 (LETTER, LANDSCAPE) 136 (LEGAL, LANDSCAPE) 113 (A4, LANDSCAPE) 113 (A5, LANDSCAPE) 113 (A6, LANDSCAPE)
		TOP M	0.5" (HP) 0.33" (Non-HP)
		BOTTOM M	0.5" (HP) 0.33" (Non-HP)

Switch	Item	Sub-Item	Factory Setting
MODE	PAGE FORMAT	LINES (HP)	60 (LETTER, PORTRAIT)
(continued)	(continued)		78 (LEGAL, PORTRAIT)
)			64 (A4, PORTRAIT)
			64 (A5, PORTRAIT)
			64 (A6, PORTRAIT)
			45 (LETTER, LANDSCAPE)
			45 (LEGAL, LANDSCAPE)
			43 (A4, LANDSCAPE)
			43 (A5, LANDSCAPE)
			43 (A6, LANDSCAPE)
		LINES (Non-HP)	62 (LETTER, PORTRAIT)
			80 (LEGAL, PORTRAIT)
			66 (A4, PORTRAIT)
			66 (A5, PORTRAIT)
			66 (A6, PORTRAIT)
			47 (LETTER, LANDSCAPE)
			47 (LEGAL, LANDSCAPE)
			45 (A4, LANDSCAPE)
			45 (A5, LANDSCAPE)
			45 (A6, LANDSCAPE)
		X OFFSET	X OFFSET=0
		Y OFFSET	Y OFFSET=0
FORMAT MODE (HP-GL)	PAGE FORMAT MODE		
	PAPER		LETTER
			(For 110/120V model)
			A4 (For 220/240V model)
		X OFFSET	X OFFSET=0
		Y OFFSET	Y OFFSET=0
	GRAPHICS MODE (HP-GL)		
	PEN SETTING		SIZE: 3 dots
			GRAY: 100%

Switch	Item	Sub-Item	Factory Setting
MODE			
(continued)			
	RESOLUTION MODE	RESOLUTION	RESOLUTION=600
	PAGE PROTECTION	-	PROTECT=AUTO
ADVANCED MODE			
NETWORK MODE			
		LOCK PANEL	LOCK PANEL=OFF
		AUTO FF	AUTO FF=OFF
		For AUTO FF=ON	WAIT TIME= 5s
		WAIT TIME	
		FF SUPPRESS	FF SUPPRESS=OFF
		TONER LOW	TONER LOW=CONT
		CONTINUE MODE	CONTINUE=MANUAL
		PRINT DENSITY	■■■■■■■■
		For any interfaces	□□□□
		INPUT BUFFER	
	PAGE COUNTER	-	0
FONT (HP)			
	PRIMARY FONT	SELECT FONT	BROUGHAM
		SYMBOL SET	ROMAN8
	SECONDARY FONT	SELECT FONT	BROUGHAM
		SYMBOL SET	ROMAN8
FONT (EPSON)			
	FONT	-	BROUGHAM
	CHARACTER SET	-	US ASCII
FONT (IBM)			
	FONT	-	BROUGHAM
	CHARACTER SET	-	PC-8
EMULATION			
	-	-	AUTO
	For AUTO mode	TIME OUT	TIME OUT= 5s
		EPSON/IBM	EPSON/IBM=EPSON
		KEEP PCL	KEEP PCL=OFF

Switch	Item	Sub-Item	Factory Setting
ECONOMY			
	POWER SAVE MODE	-	POWER SAVE=ON
		For POWER SAVE=ON TIME OUT	TIME OUT=30m
FEEDER			
	FEEDER	-	FEEDER=AUTO For FEEDER=AUTO AUTO=T1>T2>MP
	MP FIRST	-	MP FIRST=OFF
	MANUAL FEED	-	MANUAL FEED=OFF
	MP TRAY SETTING	MP SIZE	MP SIZE=LETTER (For 110/120V model) MP SIZE=A4 (For 220V/240V model)
		PAPER IN	PAPER IN=CONT
	MEDIA TYPE	-	REGULAR
	DUPLEX MODE	DUPLEX	DUPLEX=OFF
		BIND	BIND=LONG
COPY	-	-	COPY PAGES=1
LANGUAGE (FORM FEED + POWER ON)	-	-	LANG=ENGLISH

TEST Switch

You can test the printer or print out the list of fonts with the TEST switch. To do so, hold down the SHIFT switch and press the TEST switch. You will then enter the test mode where you may test the printer or print out the list of fonts.

To test the printer, follow these steps:

1. Press the SEL switch to set the printer off-line.
2. Hold down the SHIFT switch and press the TEST switch.

When you enter the test mode, the display shows the first test mode item.

TEST PRINT

3. Press the ▲ or ▼ switch until the desired test mode appears on the display.

Display Message	Test Mode
TEST PRINT	Performs the printer test and prints out the test pattern.
PRINT CONFIG	Prints out the list of panel switch settings you have configured for the printer as user settings.
PRINT FONTS I	Prints out the list of internal or resident fonts.
PRINT FONTS C	Prints out the list of optional fonts stored in the font cartridge/card.
PRINT FONTS P	Prints out the list of permanent download fonts.
exit	Exits from the test mode. The printer does not perform the test.

✍ Notes

The message “PRINT FONTS C” or “PRINT FONTS P” appears only when the optional font cartridge/card is installed in the font slot or permanent download fonts are stored in printer memory.

- If the optional font cartridge/card is installed, you can print out the list of optional fonts. Since the list shows the ID numbers specific to each optional font, it helps you to select them with the FONT switch. For further information, see “FONT Switch” in Chapter 4 and “FONT CARTRIDGE/CARD, FLASH MEMORY/HDD CARD” in Chapter 5.
- If user-defined characters are already downloaded into the printer memory as permanent download fonts, you can print out the list of them. For further information, see “FONT Switch” in Chapter 4 and Technical Reference Manual that is optionally available.

4. Press the SET switch to make the displayed selection effective.

The printer prints out the test patterns or lists according to the selected test mode.

- When the “TEST PRINT” mode has been selected, the display shows the following message and the printer starts printing out the test pattern.

05 TEST PRINT

- When the “PRINT CONFIG” mode has been selected, the display shows the following message and the printer starts printing out the list of printer settings.

06 PRINT CONFIG

✍ Note

The printed list shows the panel switch settings you have made as user settings with the MODE switch. See “SAVE SETTINGS” in Chapter 4.

■ When the "PRINT FONTS" mode has been selected, the display shows the selected mode and the printer starts printing out the font list. The display may look like this:

06 PRINT FONTS I

When the printer finishes printing, it automatically exits from the test mode to the off-line state.

HEX DUMP MODE

This printer has a useful hex dump mode for checking the print data sent from your computer. The printer lists the print data in hexadecimal form.

To enter the hex dump mode, follow these steps:

1. Check the power state.
2. Operate the switches according to the power state.
 - If the printer has been turned off, turn on the printer.

The printer starts the self-test and the display shows the following message.

04 SELF TEST

- If the printer has been turned on, reset the printer with the RESET switch.
 - 1) Press the SEL switch to set the printer off-line.
 - 2) Hold down the SHIFT switch and press the RESET switch.
The display will show “RESET PRINTER”.
 - 3) Press the SET switch with the “RESET PRINTER” selected.

The printer begins its reset and the display shows the following message alternately.

08 RESET TO

→

USER SETTINGS

3. Press the CONTINUE/SHIFT switch.

The printer checks the CONTINUE/SHIFT switch at the end of self-test or printer reset. If the switch is held down, the printer enters the hex dump mode and goes on-line. The display will show the message “HEX DUMP MODE” and the printer will return to the on-line state.

Note

If the printer returns to the on-line state without displaying the message “HEX DUMP MODE”, you did not press the CONTINUE/SHIFT switch *immediately* after pressing the SET switch. Try the above steps once again.

4. Send data from your computer.

When the printer receives data, it starts printing hexadecimal values of the received data.

To exit from the hex dump mode, follow these *basic* steps:

1. Press the SEL switch to set the printer off-line.
2. Reset the printer with the RESET switch.

Or turn off the printer, wait for a few seconds, and turn it on again.

CHAPTER 5 OPTIONS

LOWER TRAY UNIT (LT-1200)

Loading Paper from the Lower Paper Cassette

The lower tray unit is a device that functions as a third paper source which can contain a maximum of 500 sheets of paper (80 g/m² or 20 lbs). For the optional lower tray unit, consult the dealer where you purchased the printer.

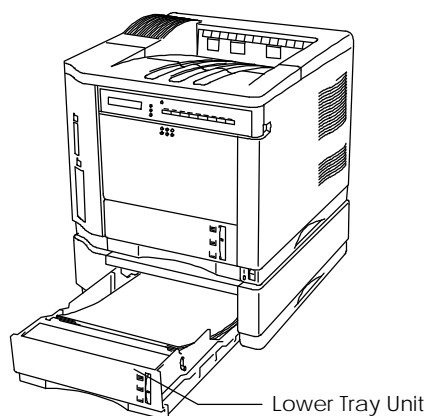

Fig. 5-1 Loading Paper in the Lower Tray Unit

With the lower tray unit installed, load paper into the lower paper cassette in the same way as you do the upper paper cassette. See “Installing the Paper Cassette” in Chapter 2.

The paper sizes available for the lower paper cassette are not the same for the upper paper cassette as shown below.

paper source	available size
the optional lower paper cassette (T2)	cut sheet : letter, legal, A4 and Executive
the multi-purpose tray (MP) and the upper paper cassette (T1)	cut sheet : letter, legal, A4, ISO B5, Executive, A5, ISO B6 and A6 envelope : COM 10 , Monarch, C5, DL and ISO B5
all sources for duplex printing (DX)	cut sheet : letter, legal, A4, ISO B5(except T2) and Executive

FONT CARTRIDGE/CARD, FLASH MEMORY/HDD CARD

Installing a Font Cartridge/Card, Flash Memory Card and HDD Card

This printer has one slot for an optional font cartridge and one slot for an optional font card, flash memory card or HDD card.

If you install the optional font cartridge/card, you can use the fonts stored in them as well as resident fonts. For optional font cartridges/cards, consult the dealer where you purchased the printer.

If you install the optional flash memory card or HDD card, you can save macros and fonts on it. For flash memory card and HDD card operation and information, see "CARD OPERATION" in Chapter 4.

Notes

- Do not install or remove cards with the printer power on, or you may lose all data from the card, or may seriously damage the card if you do this.
- For more information about the cards, consult the dealer where you purchased the printer.

Follow these steps to install or remove a cartridge/card:

1. Make sure that the printer is turned off.

If the printer is turned on, be sure to press the SEL switch to set the printer off-line. If data remains in the printer memory, the DATA lamp stays on. Press the FORM FEED switch to print out the remaining data, then the DATA lamp goes off. Turn off the printer.

2. Insert the font card, flash memory card or HDD card into the upper slot A and the font cartridge into the lower slot B with the cartridge/card label facing to the left. Make sure they fit securely.

To remove the cartridge/card, pull them out of the slot with the printer turned off.

The following type of flash memory card can be installed:

- 512 Kbyte : Mitsubishi MF8513-GBDAT01
- 1 Mbyte : Mitsubishi MF81M1-GBDAT01
- 2 Mbyte : Mitsubishi MF82M1-GBDAT01
- 4 Mbyte : Mitsubishi MF84M1-G1EAT01

- 2 Mbyte : Fujitsu MB98A81113-20
- 2 Mbyte : Fujitsu MB98A81123-25

- 1 Mbyte : Fujisoku JF1024A3-R03

- 1 Mbyte : Toshiba MCM33708DFB
- 2 Mbyte : Toshiba MCM33709DFB

- 1 Mbyte : AMD AMC001FLKA
- 2 Mbyte : AMD AMC002FLKA
- 4 Mbyte : AMD AMC004FLKA

The following type of HDD card can be installed:

- 131 Mbyte : Maxtor Corporation / Mobile Max 131

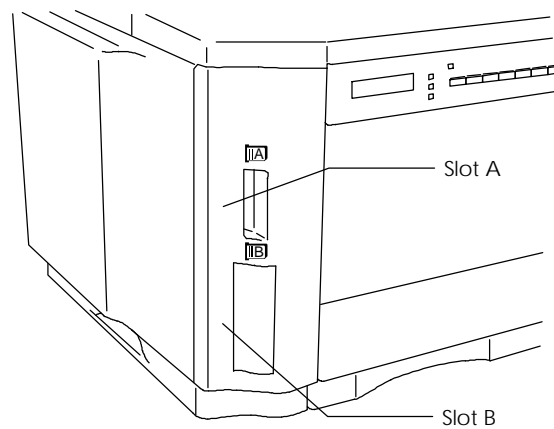

Fig. 5-2 Installing or Removing the Cartridge or Card

Selecting the Optional Fonts

After you have installed the optional font cartridge/card, you can select optional fonts by any of the following methods:

1. Through your application software
2. With a font selection command
3. With the FONT switch

When you select fonts through your application software, follow the instructions specific to your software. Refer to your software manual if you need assistance. When you select fonts with a font selection command, embed the font selection command in your program. See the Technical Reference Manual, which is optionally available for this printer.

Notes

When you select the fonts through your software or with a command, note the following:

- You do not need to be concerned about the FONT switch setting. The software or command setting overrides the switch setting.
- Be sure to install the font cartridge/card that has your desired fonts. The printer automatically selects the font that has exactly the same or similar characteristics as those you set through the software or with a command. If the installed font cartridge/card happens to have a font of similar characteristics, the printer will print in an unexpected font.

To select fonts with the FONT switch, follow these basic steps:

1. Print out the list of optional fonts in the PRINT FONTS C mode with the SHIFT and TEST switches.

See "Printing the Test Pattern or Font List" in Chapter 2.

2. Find the font slot and font ID number on the list.

Font ID

Slot A or B

FONT LIST						SLOT	FONT #
ID	FONT	SIZE	STYLE	WEIGHT	TYPEFACE	A	B
P000	9:1000000...	11.00	Upright(0)	Medium(0)	Times Roman(s)		ABCDefgh123?!"#\$%&'()*<>/12345
P001	000	11.00	Upright(0)	Medium(0)	Times Roman(s)		ABCDefgh123?!"#\$%&'()*<>/12345
P002	1001PC-0...	11.00	Upright(0)	Medium(0)	Times Roman(s)		ABCDefgh123?!"#\$%&'()*<>/12345
P003	1101PC-0...	11.00	Upright(0)	Medium(0)	Times Roman(s)		ABCDefgh123?!"#\$%&'()*<>/12345
P004	1201PC-0...	11.00	Upright(0)	Medium(0)	Times Roman(s)		ABCDefgh123?!"#\$%&'()*<>/12345
B005	70:	11.00	Upright(0)	Medium(0)	Times Roman(s)		ABCDefgh123?!"#\$%&'()*<>/12345
D006	9:1000000...	11.00	Upright(0)	Bold(3)	Times Roman(s)		ABCDefgh123?!"#\$%&'()*<>/1234

Fig. 5-3 Font ID Numbers on the Font List

3. Select the font with the FONT switch.

See "FONT Switch" in Chapter 4.

RAM EXPANSION

This printer has 2 Mbytes of memory standard and 3 slots for optional expansion memory. The memory can be expanded up to 26 Mbytes by installing commercially available single in-line memory modules (SIMMs).

Minimum Memory Recommendation
(Including 2 Mbytes of internal memory)

■ Simplex printing for any emulation modes

Page Protect = Off		
	300 dpi	600 dpi
Letter/A4	2 Mbytes	2 Mbytes
Legal	2 Mbytes	2 Mbytes

Page Protect = On		
	300 dpi	600 dpi
Letter/A4	2 Mbytes	6 Mbytes
Legal	3 Mbytes	6 Mbytes

■ Duplex printing

	300 dpi	600 dpi
HP LaserJet 4	4 Mbytes	10 Mbytes

The following capacity of a SIMM can be installed:

- 1 Mbyte HITACHI HB56D25632B-6A, -7A,
MITSUBISHI MH25632BJ-7
- 2 Mbyte HITACHI HB56D51232B-6A, -7A
MITSUBISHI MH51232BJ-7
- 4 Mbyte HITACHI HB56A132BV-7A, -7AL, -7B, -7BL
MITSUBISHI MH1M32ADJ-7
- 8 Mbyte HITACHI HB56A232BT-7A, -7AL, -7B, -7BL
MITSUBISHI MH2M32EJ-7, MH2M32DJ-7

In general, the SIMM must have the following specifications:

Type: 72 pin and 32 bit or 36 bit output
 Access Time: 80 nsec. or less
 Capacity: 1, 2, 4 or 8 Mbyte
 Height: 46mm (1.8 inches) or less

There are 40 bit output SIMMs for workstations. Such SIMMs do not fit to this printer.

For SIMMs and installation, consult the dealer where you purchased the printer.

When you install SIMMs, follow these steps:

1. Turn off the printer and unplug the power cord from the wall socket.

Note

Be sure to turn off the power to the printer before installing or removing the SIMMs.

2. Open the top cover of the printer.
3. Push the tab located on the left inside the printer to unlock the left side cover.

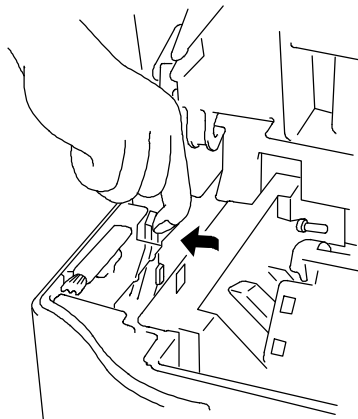

Fig. 5-4 Unlocking the Left Side Cover

4. Remove the left side cover by sliding it to the rear of the printer.

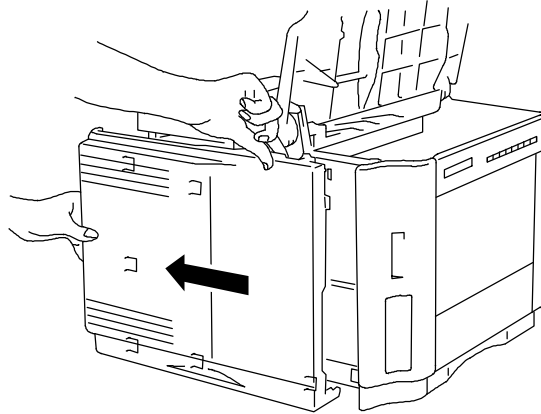

Fig. 5-5 Removing the Left Side Cover

5. Loosen the screws and then slide and remove the metal cover.

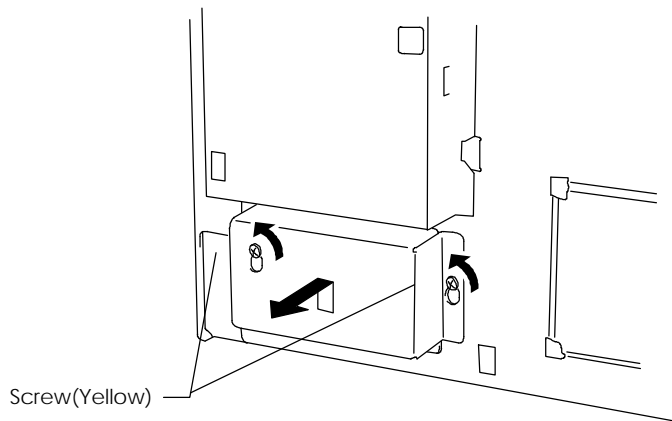

Fig. 5-6 Removing the Metal Cover

6. Unpack a SIMM and hold it on its edge.

Note

Do not touch the memory chips or the board surface. If static electricity collects, it damages the memory.

7. Install as many SIMMs as you need.
 - Set a SIMM into the slot at an angle.
 - Push the tip gently towards the vertical until it clicks into place.

Notes

- When you install less than three SIMMs, be sure to install them in the order of slots 1, 2, and 3.
- When you install different capacities of SIMMs, be sure to install the larger capacity SIMMs in the lower socket and smaller capacity SIMMs in order in the upper sockets.

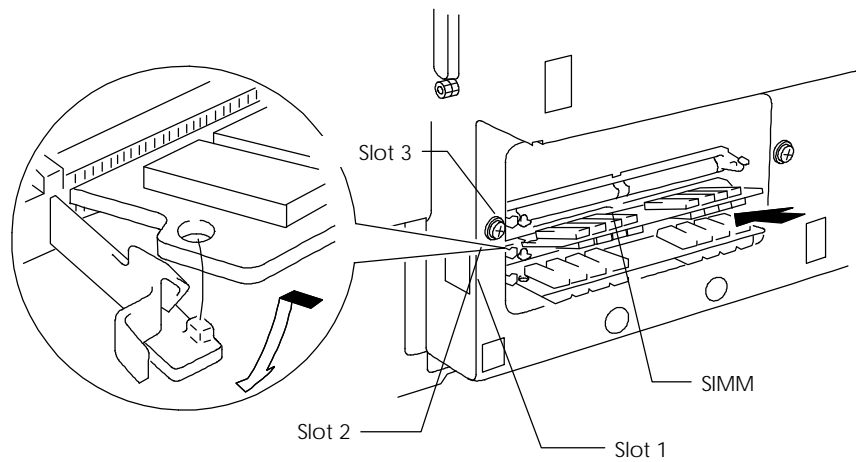

Fig. 5-7 Installing the SIMMs

8. Refit the metal plate and secure it with the screws.
9. Refit the left side cover to the printer.
10. Plug in the power cord and turn on the printer.

If you have installed the SIMMs incorrectly, the printer prints a report to alert you.

DUPLEX UNIT (DX-1200)

The duplex unit is an optional device that allows printing on both sides of pages. When it is installed, you can select either duplex printing or simplex printing from the control panel or by software command. For more information about the control panel, see “FEEDER switch” in Chapter 4.

Be sure to install the following capacity of RAM to enjoy duplex printing, or the printer cannot manage all the data for duplex printing at 600 dpi resolution and automatically switches to simplex printing or decrease the resolution from 600 dpi to 300 dpi.

■ Duplex printing

	300 dpi	600 dpi
HP LaserJet 4	4 Mbytes	10 Mbytes

Notes

- The Duplex unit can handle cut sheet paper of the sizes shown below [Weight = 60 to 105 g/m² (16 to 28 lbs)].
- When the duplex unit is installed, the capacity of the upper paper cassette decreases as shown below.
- When the printer automatically changes the setting to the 300 dpi resolution, the display temporarily shows “02 PR300” during printing.
- When the printer automatically changes the setting to the simplex printing, the display temporarily shows “02 SX” during printing.
- To ensure smooth paper feeding, when using the MP tray, load paper into the upper paper cassette. (Sometimes slight smudging on the edge of the top piece of paper in the upper paper cassette may occur.)

When the duplex unit is installed, paper handling and capacity of the upper paper cassette changes as follows:

For Duplex

paper source	available size
all sources for duplex printing (DX)	cut sheet : letter, legal, A4, ISO B5(except T2) and Executive

The upper paper cassette with duplex installed

paper source	available size	capacity
the upper paper cassette (T1)	cut sheet : letter, legal, A4,	:250 sheets/27.5mm
	ISO	:250 sheets/27.5mm
	B5,Executive	:200 sheets/24.5mm
	A5	:140 sheets/17.5mm
	ISO B6	: 80 sheets/10.0mm
	A6	: 15 sheets/20.5mm
	envelope : COM 10	: 15 sheets/20.5mm
	Monarch	: 15 sheets/20.5mm
	C5	: 15 sheets/20.5mm
	DL	: 15 sheets/20.5mm
ISO B5		

USER'S GUIDE

CHAPTER 6 MAINTENANCE

MAINTENANCE

Toner Cartridge

A new toner cartridge contains enough toner to print approximately 6,000 A4/Letter-size single-sided pages at about 5% coverage (if the print density is set at level 8).

You can check the current page count or the number of printed pages with the MODE switch (PAGE COUNTER). For further information, see “MODE Switch” in Chapter 4.

Notes

Toner consumption varies according to the image coverage on the page and the print density setting.

- The greater the image coverage, the greater the toner consumption.
- If you change the print density setting for lighter or darker printing, toner consumption varies accordingly. To adjust print density setting, see “Checking the Printed Test Pattern” in Chapter 2.

Toner Empty Message

Check printed pages, page counter, and display messages periodically. If the display shows the following message, the printer has almost run out of toner or the toner is not evenly distributed inside the cartridge.

16 TONER EMPTY

Although you can print between 30 and 100 additional pages after the toner empty message first appears, be sure to replace the toner cartridge with a new one before it becomes completely empty.

You can select the printer’s action when the “TONER EMPTY” message appears, whether to stop or continue printing. See “ADVANCED MODE” in Chapter 4.

Follow these steps to check the toner cartridge:

1. Remove the toner cartridge from the printer.

If you turn on the printer without a toner cartridge installed, the display shows the following operator call message to prompt you to install the toner cartridge.

14 NO CARTRIDGE

2. Rock the toner cartridge gently several times at a 45° angle to distribute the toner evenly inside the cartridge.
3. Install the toner cartridge again.
4. Try printing and check the printed page.

If you are not satisfied with it or the display still shows the toner empty message, replace the old toner cartridge with a new one.

Replacing the Toner Cartridge

Every time you replace the toner cartridge, you need to clean the inside of the printer. For further information on cleaning, see “Cleaning” in this chapter.

 **Note**

To ensure optimum print quality, be sure to use quality toner cartridges. To obtain toner cartridges, consult the dealer where you purchased the printer.

Before you begin the following steps, refer to “Installing the Toner Cartridge” in Chapter 2. Be sure to review the instructive diagrams.

To replace the toner cartridge, follow these steps:

1. Turn off the printer.
2. Open the top cover of the printer.
3. Lift the top of the toner cartridge slightly and pull it out of the printer.

4. Clean the anti-static teeth with a clean brush.

Note
 Never touch or clean the transfer roller, or print quality may deteriorate.

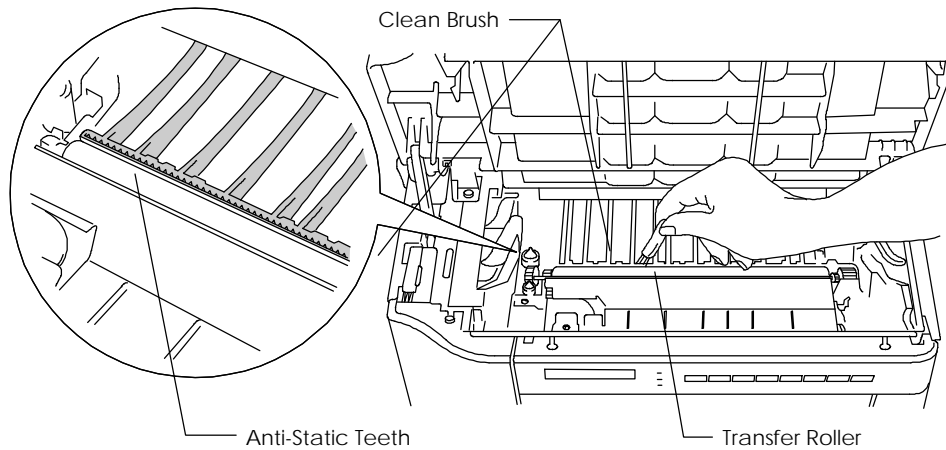

Fig. 6-1 Cleaning the Anti-Static Teeth

5. Clean the transfer guide, referring to “Cleaning the Printer Interior” in this chapter.
6. Open the bag to unpack a new toner cartridge.

Handle the toner cartridge with care.

7. Hold the toner cartridge with both hands. Rock it gently several times at a 45° angle. This distributes the toner evenly inside the cartridge.

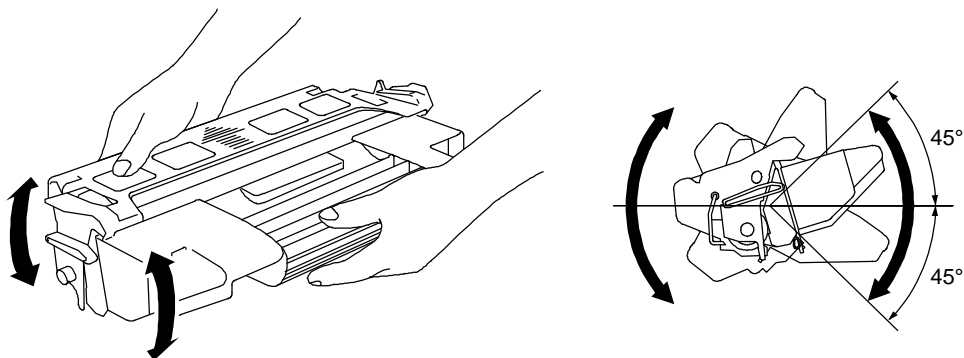

Fig. 6-2 Rocking the Toner Cartridge

8. Bend the tab up and down several times until it is detached from the toner cartridge.
9. Hold the tab firmly and pull it until the sealing tape comes out all the way.
10. Insert the toner cartridge in the direction of the arrows engraved on the cartridge into the side guides until it stops securely in the cartridge holder inside the printer.

 **Note**

Push both sides of the toner cartridge gently until the cartridge is seated correctly in place.

11. Close the top cover of the printer.

Cleaning

Clean the printer exterior and interior periodically with a dry soft cloth. When you replace the toner cartridge, be sure to clean the printer interior with a dry soft cloth. If the printed page gets stained with toner, clean the printer interior with a dry soft cloth.

Cleaning the Printer Exterior

Clean the printer exterior as follows:

1. Turn off the printer and unplug the power cord.
2. Remove the paper cassette and optional font cartridge/card.
3. Open the multi-purpose tray.
4. Wipe the printer body with a soft cloth to remove dust from it.

Dip the cloth in water and wring it out thoroughly for cleaning.

Note

Use water or neutral detergents for cleaning. Cleaning with volatile liquids such as thinner or benzine damages the surface of the printer. Do not use cleaning materials that contain ammonia. It might damage the printer, particularly the toner cartridge.

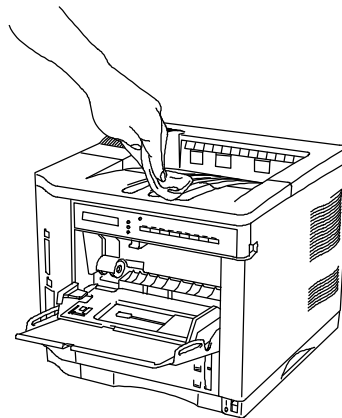

Fig. 6-3 Cleaning the Printer Exterior

5. If paper or foreign objects are stuck in the paper cassettes, remove them.

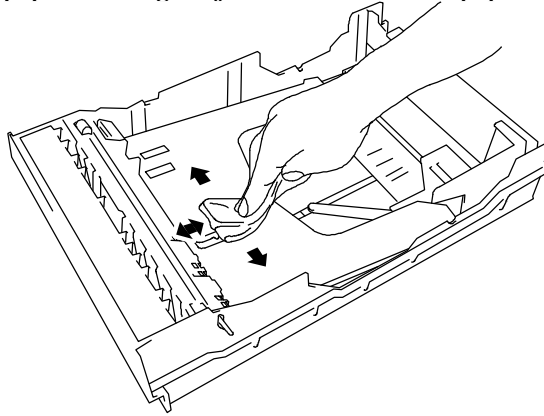

Fig. 6-4 Cleaning the Paper Cassette

6. Replace the paper cassette and the optional font cartridge/card.

Cleaning the Printer Interior

Dip a soft cloth in water and wring it out thoroughly for cleaning the printer interior.

✓ Warning & ⚠ Caution

When you clean the printer interior, pay attention to the following:

- **Never touch the hot fuser.**
- **Be careful not to inhale the toner.**
- If your clothes are smeared with toner, wipe off toner with a dry cloth and wash clothes in cold water. If you wash them in hot water, toner gets dissolved inside the material and it will not come out.
- Never touch or clean the transfer roller, or print quality may be adversely affected.

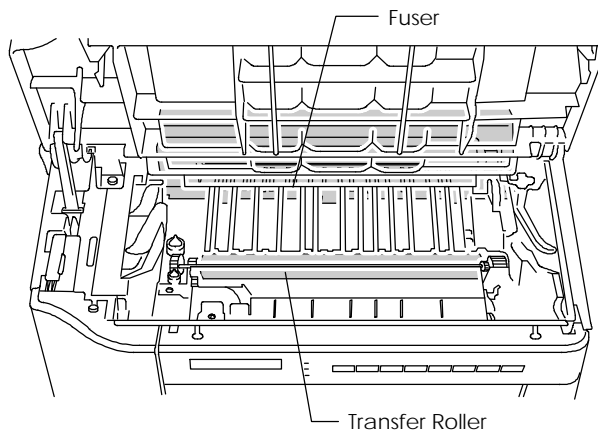

Fig. 6-5 Fuser and Transfer Roller

Clean the printer interior as follows:

1. Turn off the printer and unplug the power cord.
2. Open the top cover of the printer and remove the toner cartridge.
3. Clean both sides of the paper access cover and transfer guide by wiping off toner and paper particles with a dry, soft cloth. The paper access cover can be lifted up to allow easier access for cleaning.

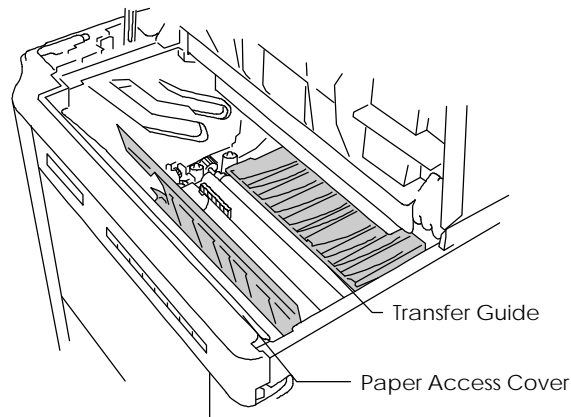

Fig. 6-6 Cleaning the Paper Access Cover and Transfer Guide

4. Wipe off toner and paper particles from the top surface of the black plastic paper guide with a dry, soft cloth.

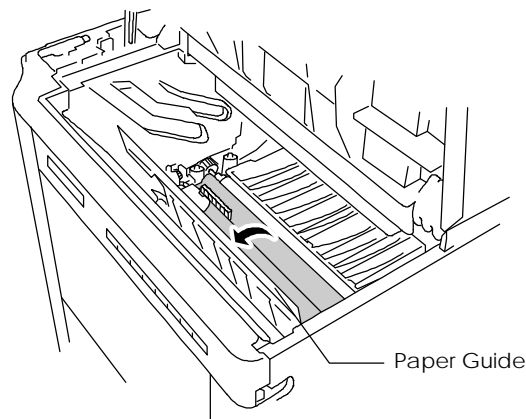

Fig. 6-7 Cleaning the Paper Guide

5. Detach the cleaning brush from the top cover and clean the anti-static teeth by sliding the brush several times. After cleaning, replace the brush in its slot.
6. Refit the toner cartridge as described in REPLACING THE TONER CARTRIDGE.
7. Close the top cover of the printer and plug in the power cord.

USER'S GUIDE

CHAPTER 7

TROUBLE SHOOTING

TROUBLESHOOTING

If any problems occur, the printer automatically stops printing, diagnoses the problem, and displays the corresponding message to alert you. Take the appropriate action, referring to the following tables. If you cannot clear the problem, consult the dealer where you purchased the printer. Inform the dealer of the message number for quick troubleshooting.

Operator Call Messages

Operator Call Message	Meaning	Action
CHECK XXXXXXXX	Check the paper tray. XXXXXXXX is MP TRAY/ TRAY 1/ TRAY 2.	Check the adjustment lever at the bottom of the upper paper cassette and adjust to the correct setting in case of CHECK TRAY 1. See page 7-6. Load a stack of paper into the cassette.
12 COVER OPEN	The upper cover of the printer is open.	Close the cover.
13 JAM XXXXXX	Paper is jammed in the printer. XXXXXX is TRAYS/ INSIDE/ REAR/ DUPLEX.	Remove the jammed paper from the indicated area. See page 7-6.
14 NO CARTRIDGE	The toner cartridge is not installed in the printer.	Install a toner cartridge.
XX NO CASSETTE	The paper cassette is not installed. XX is T1/ T2.	Install the paper cassette.
16 TONER EMPTY	The printer has almost run out of toner: you may print another 30 to 100 pages. (The ALARM lamp lights at the same time.)	Remove the toner cartridge, rock it several times at 45°, and install it again. Or replace the toner cartridge with a new one.
XX LOAD PAPER ***** SIZE	The wrong size of paper was loaded in the paper cassette XX. XX is MP/ T1/ T2.(The message appears alternately to show a particular size.)	Load the requested size of paper in the paper cassette, or load it on the manual feed tray and press the FORM FEED switch.

USER'S GUIDE

Operator Call Message	Meaning	Action
18 MANUAL FEED ***** SIZE	The printer requests you to load paper manually. (The message appears alternately to show a particular size.)	Load the requested size of paper on the multi-purpose tray and press the SEL switch.
19 CHECK FONT	An error occurred in the optional font cartridge/card.	Turn off the printer, and re-install or replace the optional font cartridge/card.
20 FONT REMOVAL	The font cartridge/card was removed while the printer is on-line.	Turn off the printer, install the font cartridge/card, and turn on the printer. The CONTINUE switch will allow you to temporarily ignore this message.
27 NO DX UNIT	The duplex unit is not installed with the printer when the duplex printing mode is selected.	Install the duplex unit correctly. See the DX-1200 user's guide.
27 NO DX TRAY	The duplex paper guide tray is not installed in T1 when duplex printing mode is selected.	Install the duplex paper guide tray into T1. See the DX-1200 user's guide.
27 DX OPEN	The cover of the duplex unit is open.	Close the cover. See the DX-1200 user's guide.

Error Messages

Error Message	Meaning	Action
31 PRINT OVERRUN	Print overrun	Press the CONTINUE switch to start printing the next page. Data which overran the print area on the page cannot be printed. Check your page protection setting with the MODE switch. Setting page protection to the correct size could solve this problem. If printing at 600 dpi, you may need to add optional SIMM memory. See page 5-6.
32 BUFFER ERROR	Input buffer overflow	Press the CONTINUE switch to resume printing. Data lost in overflow cannot be printed. See page 4-41.
34 MEMORY FULL	Work memory overflow	Press the CONTINUE switch to resume printing. If the same error should occur after you press the CONTINUE switch, turn off the printer. Wait a few seconds, then turn it on again. Reduce the input buffer size. See page 4-41. Turn off "KEEP PCL." Add SIMM memory with power off. Download font and the fonts saved in the HDD card might cause the error, for it occupies the same work area as the RAM. Memory expansion is recommended in that case. See page 5-6.
40 LINE ERROR	Error in the communications circuit	When the serial interface is used, check the communications parameters such as baud rate, code type, parity, and handshake protocols. When the parallel interface is used, check the interface cable connection.
41 PRINT CHECK	Error in communication with the engine controller	Turn off the printer. Wait a few seconds, then turn it on again.

USER'S GUIDE

Error Message	Meaning	Action
42 CARD FULL	Card overflow	Delete unnecessary macros or fonts, or use a new card. See page 4-29.
43 CARD W ERROR	Card write error	Set the write protect switch of the card to OFF if it has been set to ON. Use a new card. If the same error occurs, consult your dealer or service personnel.
44 SIMM ERROR	Incorrect installation of SIMMs	Install SIMMs correctly, referring to the printed error message. See page 5-6.
46 OPT IO ERROR	Connection error with optional feeders and duplex unit.	Check the interface cable connection between the printer and the fitted option.
47 CARD R ERROR	Card read error	Use a new card. If the same error occurs, consult your dealer or service personnel.
XX SIZE ERROR	Paper of incorrect size is loaded into XX. XX is T2/DX.	Set the correct size of paper in T2 or for duplex printing. See "Paper Handling" in Chapter 3.

Service Call Messages

Service Call Message	Meaning	Action
50 FUSER MALF	Malfunction of fuser	Turn off the printer. Wait 15 minutes, then turn it on again.
51 LASER BD MALF	Malfunction of laser beam detector	Turn off the printer. Wait a few seconds, then turn it on again.
52 SCANNER MALF	Malfunction of laser scanner motor	Turn off the printer. Wait a few seconds, then turn it on again.
53 DX FAN MALF	Malfunction of fan motor in the duplex unit.	Turn off the printer. Wait a few seconds, then turn it on again.
54 MOTOR MALF	Malfunction of main motor	Turn off the printer. Wait a few seconds, then turn it on again.
55 HIGH VOL MALF	Malfunction of high voltage power supply	Turn off the printer. Wait a few seconds, then turn it on again.
61 PROG ERROR	Program ROM checksum error	Turn off the printer. Wait a few seconds, then turn it on again.
62 FONT ERROR	Font ROM checksum error	Turn off the printer. Wait a few seconds, then turn it on again.
63 D-RAM ERROR	D-RAM error	Turn off the printer. Wait a few seconds, then turn it on again.
66 NV-W ERROR	NV-RAM error	Turn off the printer. Wait a few seconds, then turn it on again.
67 NV-R ERROR	NV-RAM error	Turn off the printer. Wait a few seconds, then turn it on again.
68 NV-B ERROR	NV-RAM error	Turn off the printer. Wait a few seconds, then turn it on again.
60 SYSTEM ERROR	System error	Turn off the printer. Wait a few seconds, then turn it on again.

Possible Problems

This printer has been designed to be trouble free. However, if any problem should occur, note the display message and take the appropriate action. This section describes the actions to be taken against paper jams and unsatisfactory printouts.

Paper Jam

If paper jams in the printer, it stops printing and displays the following message.

13 JAM XXXXXX

Notes

If paper jams frequently occur, check the adjustment lever located in the bottom of the paper cassette or clean the printer interior and check the paper quality.

About the Adjustment Lever

If paper is misfeeding or doublefeeding frequently, set the adjustment lever according to the table below.

Recommended Paper Size

- I. Backwards : letter, legal, A4, ISO B5, Executive and A5
- II. Forwards : ISO B6, A6, COM10, Monarch, C5 and DL

If CHECK TRAY is shown when the paper cassette is filled with paper, check the adjustment lever and adjust to the correct setting.

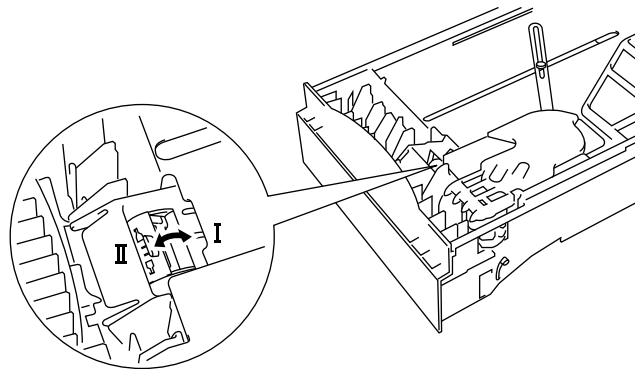

Fig. 7-1 Adjustment Lever

Do not use the following paper:

- Bent paper
- Moist paper
- Paper that does not meet specifications

Paper may jam in the paper cassette, inside the printer, at the rear access cover or at the paper exit. Check the jam location and follow the instructions below to remove the jammed paper.

After you have followed the instructions, the printer automatically resumes printing. However, the DATA lamp may come on and the following message may appear on the display.

07 FF PAUSE

After a paper jam has occurred, data usually remains in the printer memory. The message prompts you to execute a form feed and print out the remaining data. Press the SEL switch to continue.

■ Paper Jam at Paper Exit

13 JAM REAR

If paper has passed behind the rear access cover and a paper jam has occurred at the paper exit, remove the jammed paper by pulling it slowly from the exit as shown below:

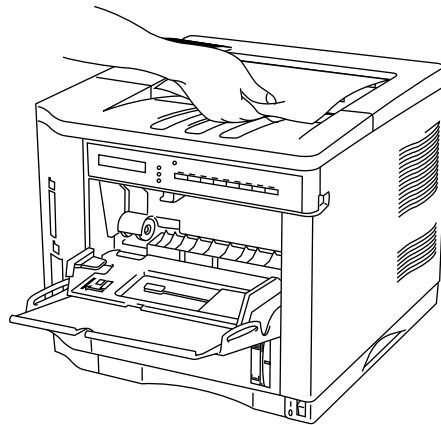

Fig. 7-2 Paper Jam at Paper Exit

■ Paper Jam at Rear Access Cover

13 JAM REAR

If a paper jam occurs behind the rear access cover before the paper exit, remove the jammed paper as follows:

1. Open the rear access cover.
2. Pull out the jammed paper slowly in direction A or B.

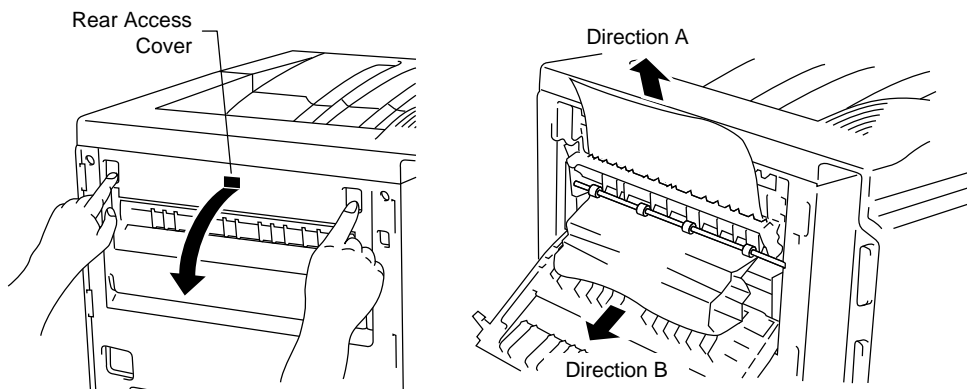

Fig. 7-3 Paper Jam at Rear Access Cover

3. Close the rear access cover.

■ Paper Jam at Fixing Roller inside the printer

13 JAM INSIDE

If a paper jam occurs at the fixing roller, follow these steps to remove the jammed paper:

1. Open the top cover and remove the toner cartridge.
2. Remove the jammed paper by holding it with both hands and pulling it slowly towards you.



Warning

The fixing roller is extremely hot during operation. Remove the paper carefully.

Caution

- After having removed the jammed paper, if the printed paper has a stain, print several pages before restarting your printing.
- Remove the jammed paper carefully so as not to spread toner.
- Take care not to stain your hands and clothes with toner. Wash out toner stains immediately with cold water.
- Never touch the transfer roller.

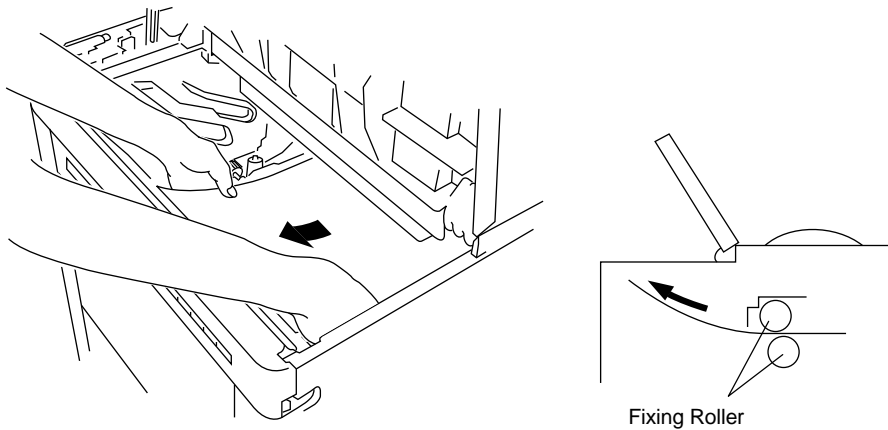

Fig. 7-4 Paper Jam at Fixing Roller

3. Install the toner cartridge and close the top cover.

■ Paper Jam at the Paper Access Cover Inside the Printer

13 JAM INSIDE

If a paper jam occurs at the paper access cover, follow these steps to remove the jammed paper:

1. Pull the upper paper cassette out of the printer to release the edge of the paper from the paper feed roller, or the paper might be torn and difficult to remove.
2. Open the top cover and remove the toner cartridge.
3. Raise the paper access cover.
4. Remove the jammed paper using the following methods:

If paper has passed through the paper access cover and toner is on the paper, pull it with making paper edge round in direction A (toward the upper side of the printer).

⚠ **Caution**

Take care not to stain your hands and clothes with toner. Wash out toner stains immediately with cold water.

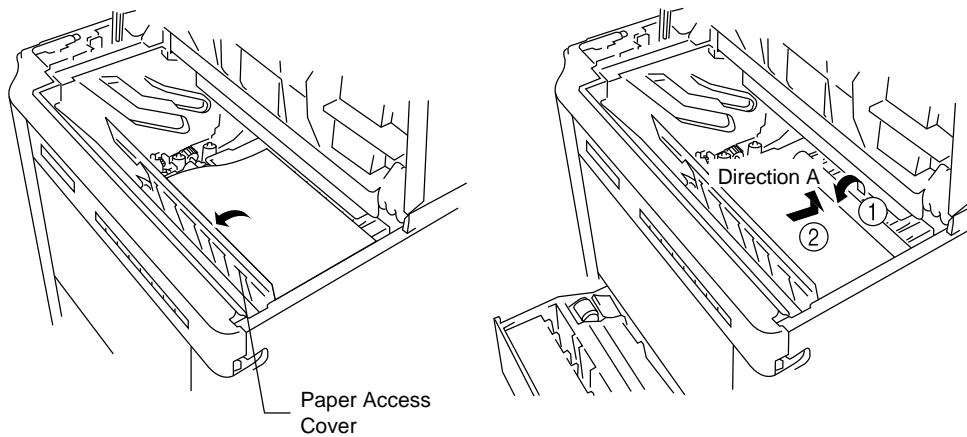

Fig. 7-5 Paper Jam at Paper Access Cover

5. Close the paper access cover.
6. Install the toner cartridge and close the top cover.

■ Paper Jam in the Paper Cassette

13 JAM TRAYS

If a paper jam occurs inside the paper cassette, follow these steps:

1. Pull out the paper cassette.
2. Remove the jammed paper.

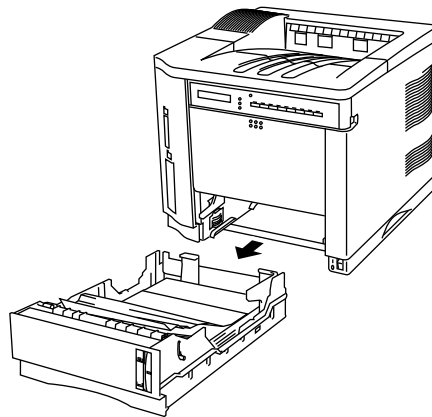

Fig. 7-6 Paper Jam at Paper Cassette

3. Install the paper cassette.

⚠ **Caution**

Do not pull out the upper paper cassette while paper is being fed from the lower paper cassette, or it causes a paper jam.

■ Paper Jam in the Multi-purpose Tray

13 JAM TRAYS

If a paper jam occurs in the multi-purpose tray, follow these steps:

1. Remove the jammed paper in the multi-purpose tray.
2. Reset all the paper on the multi-purpose tray correctly.
3. Open and close the top cover.

Unsatisfactory Printouts

If you are not satisfied with the printout quality, check the problem and take the necessary action to clear it.

Note

It is possible that paper could meet all of the guidelines listed in the specifications and still not print satisfactorily. This may be due to temperature, humidity or other variables over which the printer has no control. If you cannot clear print problems, consult the dealer where you purchased the printer.

■ Unclear Printouts

The printed page may have white stripes or faint images.



Fig. 7-7 White Stripes or Faint Images

If you see these print problems, check for the toner empty message. The toner may not be distributed evenly in the cartridge or the toner cartridge may be empty.

16 TONER EMPTY

Follow these steps to clear the problem:

1. Open the top cover of the printer.

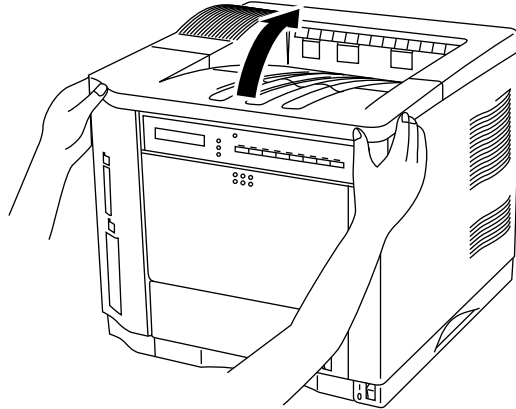

Fig. 7-8 Opening the Top Cover

2. Remove the toner cartridge from the printer.

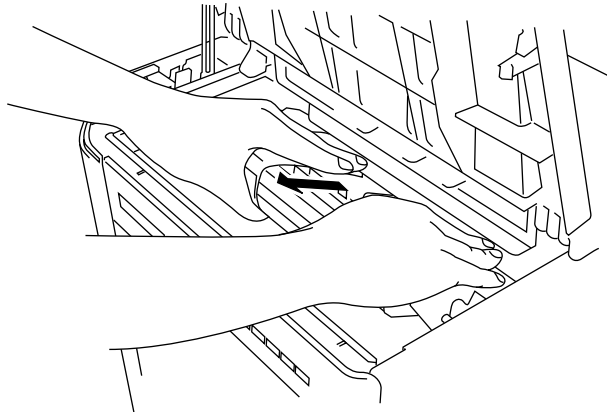

Fig. 7-9 Removing the Toner Cartridge

3. Rock the cartridge gently several times at a 45° angle.

This distributes the toner evenly inside the cartridge.

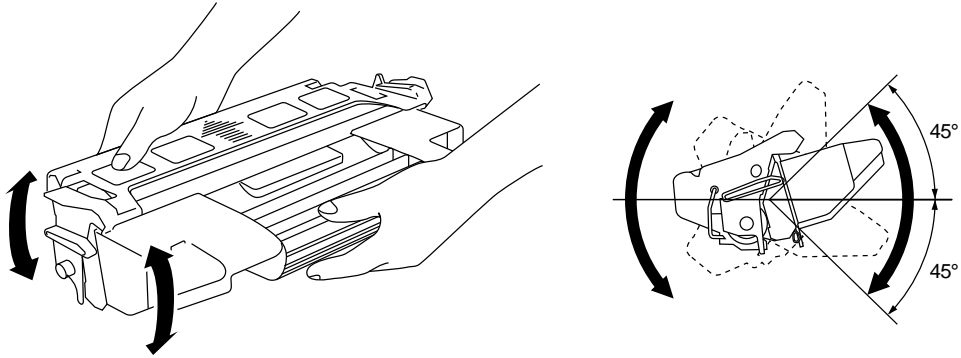

Fig. 7-10 Distributing the Toner Evenly

4. Install the toner cartridge and close the top cover of the printer.
5. Print out several pages.

If you are still not satisfied with the printout, replace the toner cartridge with a new one.

■ Stains and Stripes

If the printed page is stained with toner or has vertical stripes, clean the printer interior. See “Cleaning” in Chapter 6.

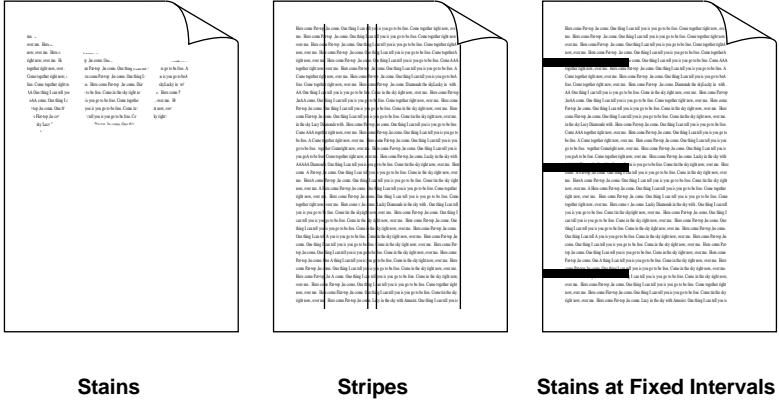

Fig. 7-11 Dark Stripes or Toner Stains

If the same print problem occurs after cleaning, take any of the following actions:

- Make sure that you use paper or OHP films that meet specifications and have the correct printing surface.
- Check that the toner cartridge is not damaged. If it is damaged, replace it with a new one.

If the stripes or stains are vertically repetitive on a page, take the following action in accordance with the intervals of the stripes or stains.

Interval	Action
95 mm or 3.7"	Replace the toner cartridge.
53 mm or 2.1"	Print several pages. *
51 mm or 2.0"	Replace the toner cartridge.
38 mm or 1.5"	Replace the toner cartridge.

* If the problem occurs repeatedly, the transfer roller needs to be replaced with a new one. Consult your dealer or sales personnel.

■ White Spots

The printed page may have white spots in black text and graphics areas. Make sure that you use paper or OHP films that meet specifications and have the correct printing surface.

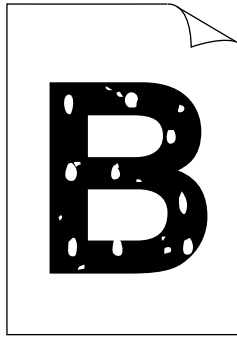

Fig. 7-12 White Spots

■ Toner Scatter

If toner scatters around printed characters and stains the printed page, clean the printer interior. See “Cleaning” in Chapter 6.

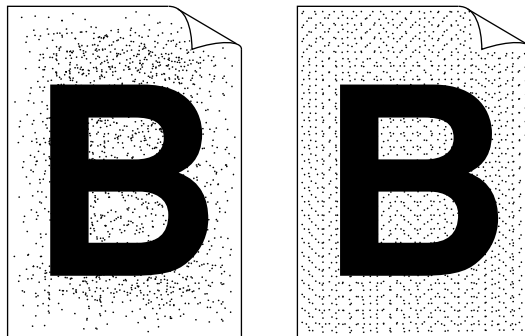

Fig. 7-13 Toner Scatter

If the same print problem occurs after cleaning, take any of the following actions:

- Make sure that you use paper, OHP films, or envelopes that meet specifications.
- Check for glue on the paper. Glue causes toner to scatter.
- If toner scatters over the entire printing surface, adjust the print density. See “Checking the Printed Test Pattern” in Chapter 2.

■ Black Page

If an entire page is printed in black, make sure that the toner cartridge is properly installed. Never use heat-sensitive paper, or it may cause this problem.

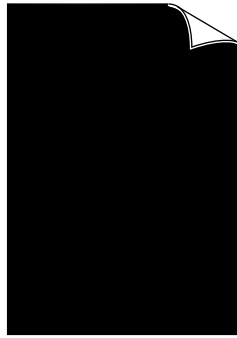

Fig. 7-14 Black Page

■ White Page

If nothing is printed on pages, make sure that the toner cartridge is not empty, the sealing tape is removed from the toner cartridge, or you use paper, OHP films, or envelopes that meet specifications.

If a stack of paper is not fanned, more than one sheet may be loaded at a time, which may cause blank pages to be ejected.



Fig. 7-15 White Page

■ Dropout

If nothing or part of a page is printed, make sure that the toner cartridge is not empty or the toner is evenly distributed in the cartridge. Take the proper action, referring to “Unclear Printouts” in this section.

Also, make sure that you use paper, OHP films or envelopes that meet specifications. Moist paper causes this problem.

If the print density is set too low, this problem may occur. Adjust the print density to the proper setting. See “Checking the Printed Test Pattern” in Chapter 2.

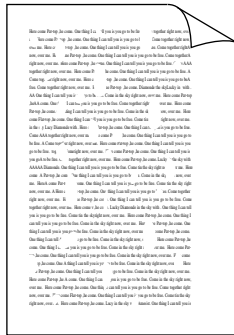

Fig. 7-16 Dropout

⚠ Caution

Operation of the printer in excess of the specifications shall be deemed abuse and all repairs thereafter shall be the sole liability of the end user/purchaser.

(For USA & CANADA Only)

For technical and operational assistance, please call:

In USA	1-800-276-7746 (outside California) 714-859-9700 (within California)
In Canada	1-800-361-6466

If you have comments or suggestions, please write us at:

In USA	Printer Customer Support Brother International Corporation 15 Musick Irvine, CA 92718
In Canada	Brother International Corporation, Ltd. 1, Rue Hôtel De Ville Dollard-des-Ormeaux P.Q. Canada H9B3H6

BBS

For downloading drivers from our Bulletin Board Service, call 1-714-859-2610. Please logon to our BBS with your first name, last name and a four digit number for your password. Our BBS supports modem speeds up to 14,400, 8 bits no parity, 1 stop bit.

DEALERS/SERVICE CENTERS

For the name of an authorized dealer or service center, call 1-800-284-4357.

USER'S GUIDE

APPENDICES

PRINTER SPECIFICATIONS

Printing

Print Method	Electrophotography by semiconductor laser beam scanning
Laser	Wavelength: 780 nm Pulse duration: 80 ns Output: 5 mW max.
Resolution	600 dots per inch
Print Speed	12 pages per minute (A4/Letter size)
Warm Up	Max. 1 minute at 20°C (68°F)
First Print cassette first	20 seconds or less (A4 size by face down print delivery from feed) Prestart by software command for 10 second print
Print Media pages/cartridge set at	Toner in a single-component cartridge Life Expectancy: 6,000 single-sided (A4 or letter size paper with the print density level 8 with about 5% coverage).
Resident Printer Fonts see	<ul style="list-style-type: none"> • 19 scalable fonts • 10 bitmapped fonts For further information about resident fonts, “RESIDENT FONTS” in Appendix.

Functions

CPU	79R3041 20 MHz (MIPS R3000 architecture)
Emulation	Automatic emulation selection <ul style="list-style-type: none">• HP LaserJet 4 (PCL 5^e)• HP-GL• EPSON FX-850• IBM Proprinter XL
Interface directional	Automatic interface selection between bi-parallel and RS-232C serial interface. For further information, see the section "INTERFACE SPECIFICATIONS" in Appendix.
RAM	2 Mbyte (expandable to 26 Mbytes with SIMMs)
Font Cartridge/Card Slots	2 slots 1 font cartridge slot: HP LaserJet Compatible 1 card slot: PCMCIA Type III Compatible
Control Panel crystal	8 switches, 4 lamps, and 16-column liquid display
Diagnostics	Self-diagnostic program

Electrical and Mechanical

Power Source	U.S.A. and Canada: AC 110 to 120 V, 60 Hz Europe and Australia: AC 220 to 240 V, 50 Hz
Power Consumption	Printing: 500 WH or less Stand-by: 80 WH or less Stand-by in sleep mode: 20 WH or less
Noise	Printing: 49 dB A or less Stand-by: 40 dB A or less
Temperature	Operating: 10 to 32.5°C (50°F to 90.5°F) Storage: 0 to 35°C (38°F to 95°F)
Humidity	Operating: 20 to 80% (without condensation) Storage: 10 to 80% (without condensation)
Dimensions (W x H x D) inches)	371.6 x 326.5 x 393 mm (14.8 x 12.9 x 15.5 inches)
inches)	371.6 x 446.5 x 393 mm (14.8 x 17.6 x 15.5 with an optional lower tray unit fitted
Weight tray	Approx. 15 kg (33 lbs.) Approx. 21.0 kg (46.3 lbs.) with optional lower unit and toner cartridge fitted .

PAPER SPECIFICATIONS

Paper Input

Cassettes :

- Standard upper cassette (Tray 1)
- Optional lower cassette (Tray 2)
- Paper size:
 - TRAY 1: Letter, legal, A4, ISO B5, Executive, A5, ISO B6, A6, COM10, Monarch, C5 and DL
 - TRAY 2: Letter, legal, A4 and Executive (OPTION)
- Max. stacking height in the cassette = 55mm(2.1")
- Max. paper cassette capacity = Approx. 500 sheets of 80 g/m² (20 lbs) when duplex unit installed = Approx. 250 sheets 80 g/m² (20 lbs) A4/letter (Tray 1)

of

Multi-purpose tray :

Multi-purpose tray capacity = Approx. 150 sheets of 80 g/m² (20 lbs)

Printed Output

Face down print delivery: Approx. 250 sheets
Face up output delivery

Paper Type

Cassette Feed:

Standard upper cassette (Tray 1) :

- Plain paper of letter, legal, A4, ISO B5, A5, ISO B6, A6 and Executive sizes [60 to 105 g/m² (16 to 28 lbs)]
- Envelopes of COM10, Monarch, C5, DL and ISO B5 sizes

Multi-purpose tray (MP tray) :

- Plain paper from 90 x 148 mm to 216 x 356 mm (from 3.5" x 5.8" to 8.5" x 14") [60 to 135 g/m² (16 to 36 lbs)]
- Overhead projector (OHP) films
- Colored paper
- Postcards
- Label stock
- Envelopes of COM10, Monarch, C5, DL and ISO B5 sizes

Optional lower cassette (Tray 2) :

Plain paper of letter, legal, A4 and Executive

sizes

[60 to 90 g/m² (16 to 24 lbs)]

The Test printing on paper, especially envelopes, is recommended before making a large purchase. following types of envelopes are not recommended for use.

- Envelopes with thick and/or crooked edges
- Damaged, curled, wrinkled, or irregularly shaped envelopes
- Extremely shiny or highly textured envelopes
- Envelopes with clasps
- Envelopes of baggy construction
- Envelopes not sharply creased
- Embossed envelopes
- Envelopes already printed with a laser printer
- Envelopes pre-printed on the inside
- Envelopes that cannot be arranged uniformly when placed in a pile

✍ Notes

- An area 15 mm (0.6") from the edges of the envelope will not be printed.
- Avoid feeding labels with the carrier sheet exposed. Otherwise, your printer will be damaged.
- When feeding OHP film, the use of a recommended type for laser printers will ensure optimum printing. For detailed information on the specification or purchase, please contact your nearest authorized sales representative or the place of purchase.

■ PAPER

The printer is designed to work well with most types of xerographic and bond paper. However, some paper variables may have an effect on print quality or handling reliability. Always test samples of paper before buying to ensure that it provides desirable performance. Some important guidelines when selecting paper are:

1. Supplier should be informed that the paper or envelopes will be used in a laser printer.
2. Preprinted papers must use inks that can withstand the temperature of the printers fusing process. (200 degrees centigrade)
3. If selecting a cotton bond paper, paper having a rough surface such as cockle or laid finished paper, or paper that is wrinkled or puckered may exhibit degraded performance.

Note

The manufacturer neither warrants or recommends the use of any particular paper. The operator is responsible for the quality of paper used with the printer.

Paper Types to Avoid

Some types of paper might not perform well or may cause damage to your printer.

Types of paper to avoid are:

1. Highly textured paper.
2. Smooth or shiny paper.
3. Paper that is coated or has a chemical finish.
4. Damaged, wrinkled or prefolded paper.
5. Paper exceeding the recommend weight specification specified in the manual.
6. Paper with tabs and staples.
7. Letterheads using low temperature dyes or thermography.
8. Multipart or carbonless paper.

DAMAGE OR OTHER DEFECTS CAUSED BY THE USE OF PAPERS LISTED UNDER "PAPER TYPES TO AVOID" WILL NOT BE COVERED UNDER ANY WARRANTY OR SERVICE AGREEMENTS.

■ ENVELOPES

Most envelopes will perform acceptably on your printer. However; some envelopes will have feeding and print quality problems because of their construction. A suitable envelope should have edges with a straight, well creased folds and should not have more than two thickness of paper along the lead edge. The envelope should lie flat and not have baggy or flimsy construction. Purchase quality envelopes only from a supplier who understands that the envelopes will be used in a laser printer. All envelopes should be tested prior to use to ensure desirable print results.

Envelope Types to Avoid

1. Envelopes constructed with a paper with a weight that exceeds the paper weight specifications for the printer.
2. Poorly manufactured envelopes with edges that are not straight or consistently square.
3. Envelopes with "baggy" construction or folds that are not sharply creased.
4. Envelopes with transparent windows, holes, cutouts or perforations.

5. Envelopes with clasps, snaps or tie strings.
6. Envelopes made with smooth or shiny paper.
7. Envelopes that are rough, highly textured, or deeply embossed.
8. Envelopes which do not lie flat or that are curled, wrinkled, or irregularly shaped.
9. Envelopes having an open flap with an adhesive that seals the envelope.

USE OF ANY OF THE ENVELOPES LISTED ABOVE MAY CAUSE DAMAGE TO YOUR PRINTER. SUCH DAMAGE IS NOT COVERED UNDER ANY WARRANTY OR SERVICE AGREEMENT.

Note

The manufacturer neither warrants nor recommends the use of a particular envelope because envelope properties are subject to change by the envelope manufacturer. The entire responsibility for the quality and performance of the envelope lies with the customer.

■ LABELS AND OVERHEAD TRANSPARENCIES

The printer will print on most type of labels and transparencies designed for use with a laser printer. Labels should have an adhesive that is acrylic-based since such material is more stable at the high temperatures in the fusing unit. Adhesives should not come in contact with any part of the printer, because the label stock may stick to the drum or rollers and cause jams and print quality problems. No adhesive should be exposed between the labels. Labels should be arranged so that they cover the entire page with the only exposed spaces being lengthwise down the sheet. Using labels with spaces may result in labels peeling off and causing serious jam or print problems.

All labels and transparencies used in this printer must be able to withstand a temperature of 200 degrees centigrade (392 degrees Fahrenheit) for a period of 0.1 seconds.

Label and transparency sheets should not exceed the paper weight specifications described in the User's Guide. Labels and transparencies exceeding this specification may not feed or print properly and cause damage to your printer.

The entire responsibility for the quality and performance of labels and transparencies lies with the customer.

DAMAGE CAUSED BY THE USE OF UNSATISFACTORY LABELS OR TRANSPARENCIES IS NOT COVERED UNDER ANY WARRANTY OR SERVICE AGREEMENTS.

INTERFACE SPECIFICATIONS

Bi-directional Parallel Interface

Interface Connector

A shielded cable with the following pin assignment should be used. Most existing parallel cables support bi-directional communication, but some might have incompatible pin assignments.

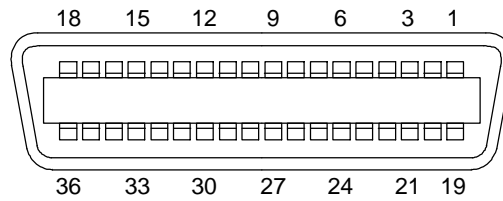

Fig. A-1 Parallel Interface Connector

Pin Assignment

Pin No.	Signal	Pin No.	Signal
1	$\overline{\text{DATA STROBE}}$	19	Twisted pair ground
2	DATA 0	20	Twisted pair ground
3	DATA 1	21	Twisted pair ground
4	DATA 2	22	Twisted pair ground
5	DATA 3	23	Twisted pair ground
6	DATA 4	24	Twisted pair ground
7	DATA 5	25	Twisted pair ground
8	DATA 6	26	Twisted pair ground
9	DATA 7	27	Twisted pair ground
10	$\overline{\text{ACKNLG}}$	28	Twisted pair ground
11	BUSY	29	Twisted pair ground
12	PE	30	$\overline{\text{INPUT PRIME RET}}$
13	SLCT	31	$\overline{\text{INPUT PRIME}}$
14	$\overline{\text{AUTO FEED}}$	32	$\overline{\text{FAULT}}$
15	N.C.	33	N.C.
16	0V	34	N.C.
17	0V	35	N.C.
18	+5V	36	$\overline{\text{SELECT IN}}$

Signal Description

Pin No.	Signal Name	IN/OUT	Explanation
1	$\overline{\text{DATA STROBE}}$	IN	Data is latched at the leading edge of this signal.
2 - 9	DATA 0 - 7	IN	Parallel 8 bit data
10	$\overline{\text{ACKNLG}}$	OUT	Data reception is completed and the printer is ready for the next data reception when this signal becomes low.
11	BUSY	OUT	The printer cannot receive data when this signal is high. The signal becomes high under data receiving, off-line, or error states.
12	PE	OUT	This signal becomes high when a paper empty state is detected.
13	SLCT	OUT	This signal becomes high when the printer is selected and low when it is deselected.
14	$\overline{\text{AUTO FEED}}$	IN	This signal is used only for the bi-directional interface as Host is busy.
31	$\overline{\text{INPUT PRIME}}$	IN	No connection inside
32	$\overline{\text{FAULT}}$	OUT	This signal becomes low when the printer is in the paper empty, off-line, or error states.
36	$\overline{\text{SLCT IN}}$	IN	This signal is used only for the bi-directional interface as $\overline{\text{R/W}}$.

Parallel Cable Connection for IBM-PC/AT or Compatible Computers and IBM-PS/2 Computers

Signal	Printer Pin	Computer Pin
DATA STROBE	1	1
DATA 0	2	2
DATA 1	3	3
DATA 2	4	4
DATA 3	5	5
DATA 4	6	6
DATA 5	7	7
DATA 6	8	8
DATA 7	9	9
ACKNLG	10	10
BUSY	11	11
PE	12	12
SLCT	13	13
AUTO FEED	14	14
GND	19 - 30	18 - 25
FAULT	32	15
SLCT IN	36	17

RS-232C Serial Interface

Standard Specifications

- 1) Baud rate: 150, 300, 600, 1200, 2400, 4800, 9600, 19200, 38400, or 57600 baud
- 2) Synchronization: Start-stop
- 3) Communications control: No protocol
- 4) Data length: Serial 7 bits or 8 bits
- 5) Parity: Odd, even, or none
- 6) Stop bit: 1 or 2 stop bits
- 7) Protocol: Xon/Xoff or DTR

Interface Connectors

A shielded cable should be used.

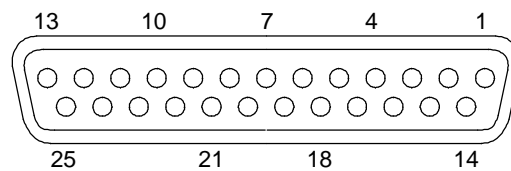

Fig. A-2 Serial Interface Connector

Pin Assignment

Pin No.	Signal	IN/OUT Printer Controller	Pin No.	Signal	IN/OUT Printer Controller
1	FG	←→	14	NC	
2	SD	→	15	NC	
3	RD	←	16	NC	
4	RS	→	17	NC	
5	NC		18	NC	
6	DR	←	19	NC	
7	SG	←→	20	ER	→
8	NC		21	NC	
9	NC		22	NC	
10	NC		23	NC	
11	NC		24	NC	
12	NC		25	NC	
13	NC				

Signal Description

Signal Name	IN/OUT	Explanation
FG	-	Frame Ground
SD	OUT	Send Data.
RD	IN	Receive Data. Receives data transmitted from the computer.
RS	OUT	Request To Send. "SPACE" level when the printer is ready to send data to the computer.
DR	IN	Data Set Ready. When DSR is at "SPACE" level, data can be accepted.
SG	-	Signal Ground
ER	OUT	Data Terminal Ready. "MARK" level when the printer is Busy.

Serial Cable Connection for IBM-PC/AT or Compatible Computers and IBM-PS/2 Computers

The following diagrams show the pin connections for the most common serial communications.

■ DB-9 Serial Connection

When you use a computer with a 9-pin serial port, use a cable with the following pin configurations.

Printer (Male)			Computer (Female)	
SD	2	_____	2	RD
RD	3	_____	3	SD
DR (DSR)	6	_____	4	ER (DTR)
SG	7	_____	5	SG
ER (DTR)	2	_____	6	DR (DSR)
0		_____	8	CS (CTS)

■ DB-25 Serial Connection

When you use a computer with a 25-pin serial port, use a cable with the following pin configurations.

Printer (Male)			Computer (Female)	
FG	1	_____	1	FG
SD	2	_____	3	RD
RD	3	_____	2	SD
DR (DSR)	6	_____	2	ER (DTR)
			0	
SG	7	_____	7	SG
ER (DTR)	2	_____	5	CS (CTS)
0		_____	6	DR (DSR)

Note

Any pins not shown in the figures above are not connected.

SYMBOL/CHARACTER SETS

You can select the symbol and character sets with the FONT switch in the HP LaserJet 4, EPSON FX-850, and IBM Proprinter XL emulation modes. See "FONT Switch" in Chapter 4.

When you have selected the HP-GL emulation mode, you can select the standard or alternate character set with the MODE switch. See "GRAPHICS MODE" in Chapter 4.

OCR Symbol Sets

When the OCR-B font is selected, the corresponding symbol set is always used.

OCR-B

HP LaserJet 4 Mode

Roman 8 (8U)
ISO Latin1 (0N)
ISO Latin2 (2N)
ISO Latin5 (5N)

USER'S GUIDE

PC-8 (10U)
PC-8 D/N (11U)
PC-850 (12U)
PC-852 (17U)

PC-8 Turkish (9T)
Windows Latin1 (19U)
Windows Latin2 (9E)
Windows Latin5 (5T)

USER'S GUIDE

Legal (1U)
Ventura Math (6M)
Ventura Intl (13J)
Ventura US (14J)

PS Math (5M)
PS Text (10J)
Math-8 (8M)
Pi Font (15U)

USER'S GUIDE

MS Publishing (6J)
Windows 3.0 (9U)
Desktop (7J)
MC Text (12J)

The following table shows characters available only in the corresponding character set. The numbers at the top of the table are hexadecimal code values with which characters are to be replaced in the Roman 8 character set. For other characters, see the Roman 8 character set.

SYMBOL SET	23	24	40	5B	5C	5D	5E	60	7B	7C	7D	7E
ISO 2 IRV												
ISO 4 UK												
ISO 6 ASCII												
ISO10 SWE/FIN												
ISO11 Swedish												
ISO14 JISASCII												
ISO15 Italian												
ISO16 POR												
ISO17 Spanish												
ISO21 German												
ISO25 French												
ISO57 Chinese												
ISO60 NOR v1												
ISO61 NOR v2												
ISO69 French												
ISO84 POR												
ISO85 Spanish												
HP German												
HP Spanish												

EPSON Mode

US ASCII

The following table shows characters available only in the corresponding character set. The numbers at the top of the table are hexadecimal code values with which characters are to be replaced in the US ASCII character set. For other characters, see the US ASCII character set.

CHARACTER SET	23	24	40	5B	5C	5D	5E	60	7B	7C	7D	7E
German												
UK ASCII I												
French I												
Danish I												
Italy												
Spanish												
Swedish												
Japanese												
Norwegian												
Danish II												
UK ASCII II												
French II												
Dutch												
South African												

PC-8
PC-8 D/N
PC-850
PC-852

USER'S GUIDE

PC-860

PC-863

PC-865

PC-8 Turkish

IBM Mode

PC-8
PC-8 D/N
PC-850
PC-852

USER'S GUIDE

PC-860

PC-863

PC-865

PC-8 Turkish

HP-GL Mode

ANSI ASCII
9825 CHR. SET

USER'S GUIDE

**FRENCH/GERMAN
SCANDINAVIAN
SPANISH/LATIN
JIS ASCII**

ROMAN8 EXT.
ISO IRV
ISO SWEDISH
ISO SWEDISH:N

USER'S GUIDE

**ISO NORWAY 1
ISO GERMAN
ISO FRENCH
ISO U.K.**

ISO ITALIAN
ISO SPANISH
ISO PORTUGUESE
ISO NORWAY 2

Symbol Sets Supported by the Printer's Intellifont Compatible Typefaces

PCL Symbol Set		Typeface Brougham	Cleveland Cond.	Connecticut	Guatemala Antique
Set ID	Symbol Set				
8U	Roman-8	•	•	•	•
0N	ISO 8859-1 Latin1	•	•	•	•
2N	ISO 8859-2 Latin2	•	•	•	•
5N	ISO 8859-9 Latin5	•	•	•	•
10U	PC-8	•	•	•	•
11U	PC-8 D/N	•	•	•	•
12U	PC-850	•	•	•	•
17U	PC-852	•	•	•	•
9T	PC-Turk	•	•	•	•
19U	Windows 3.1 Latin1	•	•	•	•
9E	Windows 3.1 Latin2	•	•	•	•
5T	Windows 3.1 Latin5	•	•	•	•
7J	DeskTop	•	•	•	•
10J	PS Text	•	•	•	•
13J	Ventura International	•	•	•	•
14J	Ventura US	•	•	•	•
6J	Microsoft Publishing	•	•	•	•
8M	Math-8	•			
5M	PS Math	•			
6M	Ventura Math	•			
15U	PI Font	•			
1U	Legal	•	•	•	•
1E	ISO 4: United Kingdom*	•	•	•	•
0U	ISO 6: ASCII*	•	•	•	•
2U	ISO 2: IRV*	•	•	•	•
0S	ISO 11: Swedish: names*	•	•	•	•
0I	ISO 15: Italian*	•	•	•	•
1S	HP Spanish*	•	•	•	•
2S	ISO 17: Spanish*	•	•	•	•
3S	ISO 10: Swedish*	•	•	•	•
4S	ISO 16: Portuguese*	•	•	•	•
5S	ISO 84: Portuguese*	•	•	•	•
6S	ISO 85: Spanish*	•	•	•	•
0G	HP German*	•	•	•	•
1G	ISO 21: German*	•	•	•	•
0D	ISO 60: Norwegian 1*	•	•	•	•
1D	ISO 61: Norwegian 2*	•	•	•	•
0F	ISO 25: French*	•	•	•	•
1F	ISO 69: French*	•	•	•	•
0K	ISO 14: JIS ASCII*	•	•	•	•
2K	ISO 57: Chinese*	•	•	•	•
9U	Windows 3.0 Latin1	•	•	•	•
12J	MC Text	•	•	•	•
19M	Symbol				
579L	Wingdings				

*These symbol sets are variations of the Roman-8 symbol set.

PCL Symbol Set		Typeface(Continued)			
Set ID	Symbol Set	LetterGothic 16.66**	Mary- land	PC Tennessee	Utah
8U	Roman-8	•	•	•	•
0N	ISO 8859-1 Latin1	•	•	•	•
2N	ISO 8859-2 Latin2	•	•	•	•
5N	ISO 8859-9 Latin5	•	•	•	•
10U	PC-8	•	•	•	•
11U	PC-8 D/N	•	•	•	•
12U	PC-850	•	•	•	•
17U	PC-852	•	•	•	•
9T	PC-Turk	•	•	•	•
19U	Windows 3.1 Latin1	•	•	•	•
9E	Windows 3.1 Latin2	•	•	•	•
5T	Windows 3.1 Latin5	•	•	•	•
7J	DeskTop	•	•	•	•
10J	PS Text	•	•	•	•
13J	Ventura International	•	•	•	•
14J	Ventura US	•	•	•	•
6J	Microsoft Publishing	•	•	•	•
8M	Math-8	•	•	•	•
5M	PS Math	•	•	•	•
6M	Ventura Math	•	•	•	•
15U	PI Font	•	•	•	•
1U	Legal	•	•	•	•
1E	ISO 4: United Kingdom*	•	•	•	•
0U	ISO 6: ASCII*	•	•	•	•
2U	ISO 2: IRV*	•	•	•	•
0S	ISO 11: Swedish: names*	•	•	•	•
0I	ISO 15: Italian*	•	•	•	•
1S	HP Spanish*	•	•	•	•
2S	ISO 17: Spanish*	•	•	•	•
3S	ISO 10: Swedish*	•	•	•	•
4S	ISO 16: Portuguese*	•	•	•	•
5S	ISO 84: Portuguese*	•	•	•	•
6S	ISO 85: Spanish*	•	•	•	•
0G	HP German*	•	•	•	•
1G	ISO 21: German*	•	•	•	•
0D	ISO 60: Norwegian 1*	•	•	•	•
1D	ISO 61: Norwegian 2*	•	•	•	•
0F	ISO 25: French*	•	•	•	•
1F	ISO 69: French*	•	•	•	•
0K	ISO 14: JIS ASCII*	•	•	•	•
2K	ISO 57: Chinese*	•	•	•	•
9U	Windows 3.0 Latin1	•	•	•	•
12J	MC Text	•	•	•	•
19M	Symbol	•	•	•	•
579L	Wingdings	•	•	•	•

*These symbol sets are variations of the Roman-8 symbol set.

**LetterGothic 16.66 is a bitmapped font.

QUICK REFERENCE OF COMMANDS

The following tables show commands sorted by function. For further information about commands, refer to the "Technical Reference Manual," which is optionally available.

Note

I represents the lowercase *I* letter. Script notation is used because lowercase *I* and the number 1 can be easily confused with each other.

HP LaserJet 4 Mode

PCL Command Sets

Function	Command	Decimal	Hexadecimal
CONTROL CODE			
Backspace	BS	08	08
Horizontal Tab	HT	09	09
Line Feed	LF	10	0A
Form Feed	FF	12	0C
Carriage Return	CR	13	0D
Secondary Font Select	SO	14	0E
Primary font Select	SI	15	0F
Escape	ESC	27	1B
PAGE FORMAT			
Page Length	ESC & <i>I</i> # P (# lines)	27 38 108 ## 80	1B 26 6C ## 50
Top Margin	ESC & <i>I</i> # E (# lines)	27 38 108 ## 69	1B 26 6C ## 45
Text Length	ESC & <i>I</i> # F (# lines)	27 38 108 ## 70	1B 26 6C ## 46
Left Margin	ESC & a # L (# column)	27 38 97 ## 76	1B 26 61 ## 4C
Right Margin	ESC & a # M (# column)	27 38 97 ## 77	1B 26 61 ## 4D
Clear Side Margin	ESC 9	27 57	1B 39
Line Pitch	ESC & <i>I</i> # C (# /48 inch)	27 38 108 ## 67	1B 26 6C ## 43
Line Spacing	ESC & <i>I</i> # D	27 38 108 ## 68	1B 26 6C ## 44
1 line/inch	ESC & /1 D	27 38 108 49 68	1B 26 6C 31 44
2 lines/inch	ESC & /2 D	27 38 108 50 68	1B 26 6C 32 44
3 lines/inch	ESC & /3 D	27 38 108 51 68	1B 26 6C 33 44
4 lines/inch	ESC & /4 D	27 38 108 52 68	1B 26 6C 34 44
6 lines/inch	ESC & /6 D	27 38 108 54 68	1B 26 6C 36 44
8 lines/inch	ESC & /8 D	27 38 108 56 68	1B 26 6C 38 44
12 lines/inch	ESC & /12 D	27 38 108 49 50 68	1B 26 6C 31 32 44
16 lines/inch	ESC & /16 D	27 38 108 49 54 68	1B 26 6C 31 36 44
24 lines/inch	ESC & /24 D	27 38 108 50 52 68	1B 26 6C 32 34 44
48 lines/inch	ESC & /48 D	27 38 108 52 56 68	1B 26 6C 34 38 44
Character Pitch	ESC & k # H (# /120 inch)	27 38 107 ## 72	1B 26 6B ## 48
ex. 10 pitch	ESC & k 12 H	27 38 107 49 50 72	1B 26 6B 31 32 48

Function	Command	Decimal	Hexadecimal
Paper Size	ESC & / # A	27 38 108 ## 65	1B 26 6C ## 41
Executive	ESC & / 1 A	27 38 108 49 65	1B 26 6C 31 41
Letter	ESC & / 2 A	27 38 108 50 65	1B 26 6C 32 41
Legal	ESC & / 3 A	27 38 108 51 65	1B 26 6C 33 41
A4	ESC & / 26 A	27 38 108 50 54 65	1B 26 6C 32 36 41
B5	ESC & / 100 A	27 38 108 49 48 48 65	1B 26 6C 31 30 30 41
B6	ESC & / 1024 A	27 38 108 49 48 50 52 65	1B 26 6C 31 30 32 34 41
A5	ESC & / 1025 A	27 38 108 49 48 50 53 65	1B 26 6C 31 30 32 35 41
A6	ESC & / 1026 A	27 38 108 49 48 50 54 65	1B 26 6C 31 30 32 36 41
Envelopes			
Monarch	ESC & / 80 A	27 38 108 56 48 65	1B 26 6C 38 30 41
COM 10	ESC & / 81 A	27 38 108 56 49 65	1B 26 6C 38 31 41
DL	ESC & / 90 A	27 38 108 57 48 65	1B 26 6C 39 30 41
C5	ESC & / 91 A	27 38 108 57 49 65	1B 26 6C 39 31 41
CURSOR POSITIONING			
Horizontal Position	ESC & a # C (# column)	27 38 97 ## 67	1B 26 61 ## 43
Horizontal Position	ESC & a # H (# decipoint)	27 38 97 ## 72	1B 26 61 ## 48
Horizontal Position	ESC * p # X (# dot)	27 42 112 ## 88	1B 2A 70 ## 58
Vertical Position	ESC & a # R (# line)	27 38 97 ## 82	1B 26 61 ## 52
Vertical Position	ESC & a # V (# decipoint)	27 38 97 ## 86	1B 26 61 ## 56
Vertical Position	ESC * p # Y (# dot)	27 42 112 ## 89	1B 2A 70 ## 59
VECTOR GRAPHICS			
Enter HP-GL/2 Mode			
Use Previous HP-GL/2 Pen Position	ESC % 0 B	27 37 48 66	1B 25 30 42
Use Current PCL CAP	ESC % 1 B	27 37 49 66	1B 25 31 42
HP-GL/2 Plot Horizontal Size	ESC * c # K (# inch)	27 42 99 # ... # 75	1B 2A 63 # ... # 4B
HP-GL/2 Plot Vertical Size	ESC * c # L (# inch)	27 42 99 # ... # 76	1B 2A 63 # ... # 4C
Set Picture Frame Anchor Point	ESC * c 0 T	27 42 99 48 84	1B 2A 63 50 54
Picture Frame Horizontal Size	ESC * c # X (# decipoint)	27 42 99 # ... # 88	1B 2A 63 # ... # 58
Picture Frame Vertical Size	ESC * c # Y (# decipoint)	27 42 99 # ... # 89	1B 2A 63 # ... # 59

Function	Command	Decimal	Hexadecimal
RASTER GRAPHICS			
Resolution Setting			
75 dpi	ESC * t 75 R	27 42 116 55 53 82	1B 2A 74 37 35 52
100 dpi	ESC * t 100 R	27 42 116 49 48 48 82	1B 2A 74 31 30 30 52
200 dpi	ESC * t 200 R	27 42 116 50 48 48 82	1B 2A 74 32 30 30 52
150 dpi	ESC * t 150 R	27 42 116 49 53 48 82	1B 2A 74 31 35 30 52
300 dpi	ESC * t 300 R	27 42 116 51 48 48 82	1B 2A 74 33 30 30 52
600 dpi	ESC * t 600 R	27 42 116 54 48 48 82	1B 2A 74 36 30 30 52
Raster Graphics Presentation			
Orientation Oriented	ESC * r 0 F	27 42 114 48 70	1B 2A 72 30 46
Raster Oriented	ESC * r 3 F	27 42 114 51 70	1B 2A 72 33 46
Begin Raster Graphics			
Left-most Position	ESC * r 0 A	27 42 114 48 65	1B 2A 72 30 41
Current Position	ESC * r 1 A	27 42 114 49 65	1B 2A 72 31 41
Transfer Data 62 ## 57	ESC * b # W [data] (# byte)		27 42 98 ## 87 1B 2A
Set Compression Mode			
Uncoded	ESC * b 0 M	27 42 98 48 77	1B 2A 62 30 4D
Run-Length Encoded	ESC * b 1 M	27 42 98 49 77	1B 2A 62 31 4D
Tagged Image File Format	ESC * b 2 M	27 42 98 50 77	1B 2A 62 32 4D
Delta Row	ESC * b 3 M	27 42 98 51 77	1B 2A 62 33 4D
Mode 5	ESC * b 5 M	27 42 98 53 77	1B 2A 62 35 4D
Mode 9	ESC * b 9 M	27 42 98 57 77	1B 2A 62 39 4D
CCITT G3/G4 (original)	ESC * b 1152 M	27 42 98 49 49 53 50 77	1B 2A 62 31 31 35 32 4D
Compress Transfer	ESC * b # C [data] (# byte)	27 42 98 ## 67	1B 2A 62 ## 43
Raster Y Offset	ESC * b # Y (# Line)	27 42 98 # ... # 89	1B 2A 62 # ... # 59
Raster Height	ESC * r # T (# Row)	27 42 114 # ... # 84	1B 2A 72 # ... # 54
Raster Width	ESC * r # S (# Pixel)	27 42 114 # ... # 83	1B 2A 72 # ... # 53
End Raster Graphics	ESC * r B	27 42 114 66	1B 2A 72 42
PRINT MODEL			
Select Pattern			
Solid Black (default)	ESC * v 0 T	27 42 118 48 84	1B 2A 76 30 54
Solid White	ESC * v 1 T	27 42 118 49 84	1B 2A 76 31 54
HP-defined Shading Pattern	ESC * v 2 T	27 42 118 50 84	1B 2A 76 32 54
HP-defined Cross-Hatched Pattern	ESC * v 3 T	27 42 118 51 84	1B 2A 76 33 54
User defined	ESC * v 4 T	27 42 118 52 84	1B 2A 76 34 54
Brother-defined Shading Pattern (64 steps, original)	ESC * v 130 T	27 42 118 49 51 48 84	1B 2A 76 31 33 30 54
Select Source Transparency Mode			
Transparent	ESC * v 0 N	27 42 118 48 78	1B 2A 76 30 42
Opaque	ESC * v 1 N	27 42 118 49 78	1B 2A 76 31 42
Select Pattern Transparency Mode			
Transparent	ESC * v 0 O	27 42 118 48 79	1B 2A 76 30 43
Opaque	ESC * v 1 O	27 42 118 49 79	1B 2A 76 31 43

Function	Command	Decimal	Hexadecimal
PATTERN			
Horizontal Size	ESC * c # A (# dot)	27 42 99 ## 65	1B 2A 63 ## 41
Horizontal Size	ESC * c # H (# decipoint)	27 42 99 ## 72	1B 2A 63 ## 48
Vertical Size	ESC * c # B (# dot)	27 42 99 ## 66	1B 2A 63 ## 42
Vertical Size	ESC * c # V (# decipoint)	27 42 99 ## 86	1B 2A 63 ## 56
Pattern ID Setting (See note below.)	ESC * c # G (#: ID)	27 42 99 ## 71	1B 2A 63 ## 71
2% Gray	ESC * c 2 G	27 42 99 50 71	1B 2A 63 32 47
10% Gray	ESC * c 10 G	27 42 99 49 48 71	1B 2A 63 31 30 47
15 % Gray	ESC * c 15 G	27 42 99 49 53 71	1B 2A 63 31 35 47
30% Gray	ESC * c 30 G	27 42 99 51 48 71	1B 2A 63 33 30 47
45% Gray	ESC * c 45 G	27 42 99 52 53 71	1B 2A 63 34 35 47
70% Gray	ESC * c 70 G	27 42 99 55 48 71	1B 2A 63 37 30 47
90% Gray	ESC * c 90 G	27 42 99 57 48 71	1B 2A 63 39 30 47
100% Gray	ESC * c 100 G	27 42 99 49 48 48 71	1B 2A 63 31 30 30 47

Note

These gray settings can be expressed in 64 shades with ESC * v 130T and ESC * c 130 P.

USER'S GUIDE

Function	Command	Decimal	Hexadecimal
1 Horiz. Line	ESC * c 1 G	27 42 99 49 71	1B 2A 63 31 47
2 Vert. Lines	ESC * c 2 G	27 42 99 50 71	1B 2A 63 32 47
3 Diagonal Lines	ESC * c 3 G	27 42 99 51 71	1B 2A 63 33 47
4 Diagonal Lines	ESC * c 4 G	27 42 99 52 71	1B 2A 63 34 47
5 Square Grid	ESC * c 5 G	27 42 99 53 71	1B 2A 63 35 47
6 Diagonal Grid	ESC * c 6 G	27 42 99 54 71	1B 2A 63 36 47
Print pattern			
Solid Black	ESC * c 0 P	27 42 99 48 80	1B 2A 63 30 50
Erase (Solid White Area Fill)	ESC * c 1 P	27 42 99 49 80	1B 2A 63 31 50
Shaded Fill	ESC * c 2 P	27 42 99 50 80	1B 2A 63 32 50
Cross-hatched Fill	ESC * c 3 P	27 42 99 51 80	1B 2A 63 33 50
User defined	ESC * c 4 P	27 42 99 52 80	1B 2A 63 34 50
Current Pattern	ESC * c 5 P	27 42 99 53 80	1B 2A 63 35 50
Brother-defined Shading Fill (64 steps, original)	ESC * c 130 P	27 42 99 49 51 48 80	1B 2A 63 31 33 30 50
Define Pattern	ESC * c # W (#: byte)	1B 2A 63 ## 51	27 42 99 ## 87
User-defined Pattern Control			
Delete All	ESC * c 0 Q	1B 2A 63 30 51	27 42 99 48 81
Delete Temporary	ESC * c 1 Q	1B 2A 63 31 51	27 42 99 49 81
Delete Current Pattern	ESC * c 2 Q	1B 2A 63 32 51	27 42 99 50 81
Make Temporary	ESC * c 4 Q	1B 2A 63 34 51	27 42 99 52 81
Make Permanent	ESC * c 5 Q	1B 2A 63 35 51	27 42 99 53 81
Set Pattern Reference Point			
Print Direction Oriented	ESC * p 0 R	1B 2A 70 30 52	27 42 112 48 82
Logical Page Oriented	ESC * p 1 R	1B 2A 70 31 52	27 42 112 49 82

Function	Command	Decimal	Hexadecimal
DOWNLOAD FONT			
Font ID Set	ESC * c # D (#: ID)	27 42 99 ## 68	1B 2A 63 ## 44
Character Code Set	ESC * c # E (##: chara. code)	27 42 99 ## 69	1B 2A 63 ## 45
Download Control			
Delete All	ESC * c 0 F	27 42 99 48 70	1B 2A 63 30 46
Delete Temporary	ESC * c 1 F	27 42 99 49 70	1B 2A 63 31 46
Delete Current ID	ESC * c 2 F	27 42 99 50 70	1B 2A 63 32 46
Delete Current Character Code	ESC * c 3 F	27 42 99 51 70	1B 2A 63 33 46
Make Temporary	ESC * c 4 F	27 42 99 52 70	1B 2A 63 34 46
Make Permanent	ESC * c 5 F	27 42 99 53 70	1B 2A 63 35 46
Copy Assign	ESC * c 6 F	27 42 99 54 70	1B 2A 63 36 46
Download Font/Flash Memory Card (original)			
Delete One from Card	ESC * c 1026 F	27 42 99 49 48 50 54 70	1B 2A 63 31 30 32 36 46
Delete All from Card	ESC * c 1028 F	27 42 99 49 48 50 56 70	1B 2A 63 31 30 32 38 46
Save Current Font into Card	ESC * c 1029 F	27 42 99 49 48 50 57 70	1B 2A 63 31 30 32 39 46
Set to Primary Font	ESC (# X (#: font ID)	27 40 ## 88	1B 28 ## 58
Set to Secondary Font	ESC) # X (#: font ID)	27 41 ## 88	1B 29 ## 58
Font Default Setting			
Primary	ESC (# @ (#: control)	27 40 ## 64	1B 28 ## 40
Secondary	ESC) # @ (#: control)	27 41 ## 64	1B 29 ## 40
Download Font Header	ESC) s # W (#: byte)	27 41 115 ## 87	1B 29 73 ## 57
Download Character	ESC (s # W (#: byte)	27 40 115 ## 87	1B 28 73 ## 57

Function	Command	Decimal	Hexadecimal
USER-DEFINED SYMBOL SET			
Symbol Set ID Set	ESC * c # R (#: ID)	27 42 99 ## 82	1B 2A 63 ## 52
Define Symbol Set	ESC (f # W (#: byte)	27 40 102 ## 87	1B 28 66 ## 46
Symbol Set Control			
Delete All	ESC * c 0 S	27 42 99 48 83	1B 2A 63 30 53
Delete Temporary	ESC * c 1 S	27 42 99 49 83	1B 2A 63 31 53
Delete Current ID	ESC * c 2 S	27 42 99 50 83	1B 2A 63 32 53
Make Temporary	ESC * c 4 S	27 42 99 52 83	1B 2A 63 34 53
Make Permanent	ESC * c 5 S	27 42 99 53 83	1B 2A 63 35 53
MACRO			
Macro ID Set	ESC & f # Y (#: ID)	27 38 102 ## 89	1B 26 66 ## 59
Macro Control			
Start Macro Definition	ESC & f 0 X	27 38 102 48 88	1B 26 66 30 58
End Macro Definition	ESC & f 1 X	27 38 102 49 88	1B 26 66 31 58
Execute Macro	ESC & f 2 X	27 38 102 50 88	1B 26 66 32 58
Call Macro	ESC & f 3 X	27 38 102 51 88	1B 26 66 33 58
Macro Overlay ON	ESC & f 4 X	27 38 102 52 88	1B 26 66 34 58
Macro Overlay OFF	ESC & f 5 X	27 38 102 53 88	1B 26 66 35 58
Delete All Macros	ESC & f 6 X	27 38 102 54 88	1B 26 66 36 58
Delete Temporary Macro	ESC & f 7 X	27 38 102 55 88	1B 26 66 37 58
Delete Current Macro	ESC & f 8 X	27 38 102 56 88	1B 26 66 38 58
Make Temporary Macro	ESC & f 9 X	27 38 102 57 88	1B 26 66 39 58
Make Permanent Macro	ESC & f 10 X	27 38 102 49 48 88	1B 26 66 31 30 58
Macro/Card (original)			
Delete All Macros from Card	ESC & f 1030 X	27 38 102 49 48 51 48 88	1B 26 66 31 30 33 30 58
Delete Current Macro from Card	ESC & f 1036 X	27 38 102 49 48 51 54 88	1B 26 66 31 30 33 36 58
Save Current Macro into Card	ESC & f 1038 X		27 38 102 49 48 51 56 88
		1B 26 66 31 30 33 38 58	
STATUS READBACK			
Set Status Readback Location Type			
Invalid Location	ESC * s 0 T	27 42 115 48 84	1B 2A 73 30 54
Currently Selected	ESC * s 1 T	27 42 115 49 84	1B 2A 73 31 54
All Locations	ESC * s 2 T	27 42 115 50 84	1B 2A 73 32 54
Internal	ESC * s 3 T	27 42 115 51 84	1B 2A 73 33 54
Downloaded	ESC * s 4 T	27 42 115 52 84	1B 2A 73 34 54
Cartridge	ESC * s 5 T	27 42 115 53 84	1B 2A 73 35 54
Option ROM Socket	ESC * s 7 T	27 42 115 55 84	1B 2A 73 37 54
Set Status Readback Location Unit			
All Entities of Location Type	ESC * s 0 U	27 42 115 48 85	1B 2A 73 30 55
Entity 1 or Temporary	ESC * s 1 U	27 42 115 49 85	1B 2A 73 31 55
Entity 2 or Permanent	ESC * s 2 U	27 42 115 50 85	1B 2A 73 32 55
Entity 3	ESC * s 3 U	27 42 115 51 85	1B 2A 73 33 55
Entity 4	ESC * s 4 U	27 42 115 52 85	1B 2A 73 34 55
Inquire Status Readback Entity			
Font	ESC * s 0 I	27 42 115 48 73	1B 2A 73 30 49
Macro	ESC * s 1 I	27 42 115 49 73	1B 2A 73 31 49
User-defined Pattern	ESC * s 2 I	27 42 115 50 73	1B 2A 73 32 49
Symbol Set	ESC * s 3 I	27 42 115 51 73	1B 2A 73 33 49
Font Extended	ESC * s 4 I	27 42 115 52 73	1B 2A 73 34 49

Function	Command	Decimal	Hexadecimal
Flush All Pages			
Flush All Complete Pages	ESC & r 0 F	27 38 114 48 70	1B 26 72 30 46
Flush All Page Data	ESC & r 1 F	27 38 114 49 70	1B 26 72 31 46
Free Memory Space	ESC * s 1 M	27 42 115 49 77	1B 2A 73 31 4D
Echo	ESC * s # X # = Echo value (-32767 to 32767)	27 42 115 # ... # 88	1B 2A 73 # ... # 58
OTHER COMMANDS			
Push Cursor Position	ESC & f 0 S	27 38 102 48 83	1B 26 66 30 53
Pop Cursor Position	ESC & f 1 S	27 38 102 49 83	1B 26 66 31 53
Display Function			
ON	ESC Y	27 89	1B 59
OFF	ESC Z	27 90	1B 5A
Transparent Print	ESC & p # X (# byte)	27 38 112 ## 88	1B 26 70 ## 58
Perforation Skip			
ON	ESC & / 1 L	27 38 108 49 76	1B 26 6C 31 4C
OFF	ESC & / 0 L	27 38 108 48 76	1B 26 6C 30 4C
End of Line Wrap			
ON	ESC & s 0 C	27 38 115 48 67	1B 26 73 30 43
OFF	ESC & s 1 C	27 38 115 49 67	1B 26 73 31 43
Auto Underline			
ON	ESC & d # D	27 38 100 ## 68	1B 26 64 ## 44
Fix	ESC & d 0 D	27 38 100 48 68	1B 26 64 30 44
Float	ESC & d 3 D	27 38 100 51 68	1B 26 64 33 44
OFF	ESC & d @	27 38 100 64	1B 26 64 40
Half Line Feed	ESC =	27 61	1B 3D
Line Termination			
CR=CR, LF=LF, FF=FF	ESC & k 0 G	27 38 107 48 71	1B 26 6B 30 47
CR=CR+LF, LF=LF, FF=FF	ESC & k 1 G	27 38 107 49 71	1B 26 6B 31 47
CR=CR, LF=LF+CR, FF=FF+CR	ESC & k 2 G	27 38 107 50 71	1B 26 6B 32 47
CR=CR+LF, LF=LF+CR, FF=FF+CR	ESC & k 3 G	27 38 107 51 71	1B 26 6B 33 47
Print Orientation			
Portrait	ESC & / 0 O	27 38 108 48 79	1B 26 6C 30 4F
Landscape	ESC & / 1 O	27 38 108 49 79	1B 26 6C 31 4F
Reverse Portrait	ESC & / 2 O	27 38 108 50 79	1B 26 6C 32 4F
Reverse Landscape	ESC & / 3 O	27 38 108 51 79	1B 26 6C 33 4F
Print Direction	ESC & a # P (# degree)	27 38 97 # ... # 80	1B 26 61 # ... # 50
Copy Volume	ESC & / # X	27 38 108 ## 88	1B 26 6C ## 58
Paper Input Control			
Paper Eject	ESC & / 0 H	27 38 108 48 72	1B 26 6C 30 48
Feed From Upper Cassette (TRAY 1)	ESC & / 1 H	27 38 108 49 72	1B 26 6C 31 48
Manual Feed	ESC & / 2 H	27 38 108 50 72	1B 26 6C 32 48
Envelope	ESC & / 3 H	27 38 108 51 72	1B 26 6C 33 48
Feed From MP Tray	ESC & / 4 H	27 38 108 52 72	1B 26 6C 34 48
Feed From Lower Cassette (TRAY 2 or Option)	ESC & / 5 H	27 38 108 53 72	1B 26 6C 35 48

Function	Command	Decimal	Hexadecimal
Simplex/Duplex Print (Available when Duplex Unit is installed)			
Simplex	ESC & / 0 S	27 38 108 48 83	1B 26 6C 30 53
Duplex & Long-Edge Binding	ESC & / 1 S	27 38 108 49 83	1B 26 6C 31 53
Duplex & Short-Edge Binding	ESC & / 2 S	27 38 108 50 83	1B 26 6C 32 53
Paper Side Selection (Available when Duplex Unit is installed)			
Next Side	ESC & a 0 G	27 38 97 48 71	1B 26 61 30 47
Front Side	ESC & a 1 G	27 38 97 49 71	1B 26 61 31 47
Back Side	ESC & a 2 G	27 38 97 50 71	1B 26 61 30 47
Long-edge Offset	ESC & / # U (#/720 inch)	27 38 108 ## 85	1B 26 6C ## 55
Short-edge Offset	ESC & / # Z (#/720 inch)	27 38 108 ## 90	1B 26 6C ## 5A
Printer Reset	ESC E	27 69	1B 45
Self-test	ESC z	27 122	1B 7A
Job Separation	ESC & / # T	27 38 108 ## 84	1B 26 6C ## 54
Unit of Measure	ESC & u # D (# = Units/inch)	27 38 117 # ... # 68	1B 26 75 # ... # 44
Go to Other Emulations (original)			
HP-GL	ESC CR G L	27 13 71 76	1B 0D 47 4C
IBM Proprinter XL	ESC CR I	27 13 73	1B 0D 49
EPSON FX-850	ESC CR E	27 13 69	1B 0D 45
User Reset (original)			
Restore to User Settings	ESC CR ! # R # = 0 to 2	27 13 33 # 82	1B 0D 21 # 52
Factory Reset (original)			
Restore to Factory Settings	ESC CR F D	27 13 70 68	1B 0D 46 44
Execute Card Data (original)			
Execute saved card data	ESC CR ! # E	27 13 33 # 69	1B 0D 21 # 45
FONT SELECTION			
Symbol Set			
ISO 60: Norwegian 1	ESC (0 D	27 40 48 68	1B 28 30 44
ISO 61: Norwegian 2	ESC (1 D	27 40 49 68	1B 28 31 44
ISO 4: United Kingdom	ESC (1 E	27 40 49 69	1B 28 31 45
Windows 3.1 Latin1	ESC (9 E	27 40 57 69	1B 28 39 45
ISO 25: French	ESC (0 F	27 40 48 70	1B 28 30 46
ISO 69: French	ESC (1 F	27 40 49 70	1B 28 31 46
HP German	ESC (0 G	27 40 48 71	1B 28 30 47
ISO 21: German	ESC (1 G	27 40 49 71	1B 28 31 47
ISO 15: Italian	ESC (0 I	27 40 48 73	1B 28 30 49
Microsoft Publishing	ESC (6 J	27 40 54 74	1B 28 36 4A
Desk Top	ESC (7 J	27 40 55 74	1B 28 37 4A
PS Text	ESC (10 J	27 40 49 48 74	1B 28 31 30 4A
MC Text	ESC (12 J	27 40 49 50 74	1B 28 31 32 4A
Ventura International	ESC (13 J	27 40 49 51 74	1B 28 31 33 4A
Ventura US	ESC (14 J	27 40 49 52 74	1B 28 31 34 4A
ISO 14: JIS ASCII	ESC (0 K	27 40 48 75	1B 28 30 4B
ISO 57: Chinese	ESC (2 K	27 40 50 75	1B 28 32 4B
ISO 8859-1 (ECMA-94) Latin1	ESC (0 N	27 40 48 78	1B 28 30 4E

Function	Command	Decimal	Hexadecimal
Wingdings	ESC (5 9 L	27 40 53 55 57 76	1B 28 35 37 39 4C
PS Math	ESC (5 M	27 40 53 77	1B 28 35 4D
Ventura Math	ESC (6 M	27 40 54 77	1B 28 36 4D
Math-8	ESC (8 M	27 40 56 77	1B 28 38 4D
Symbol	ESC (19 M	27 40 49 57 77	1B 28 31 39 4D
ISO 8859-2 Latin2	ESC (2 N	27 40 50 78	1B 28 32 4E
ISO 8859-5 Latin5	ESC (5 N	27 40 53 78	1B 28 35 4E
ISO 11: Swedish	ESC (0 S	27 40 48 83	1B 28 30 53
HP Spanish	ESC (1 S	27 40 49 83	1B 28 31 53
ISO 17: Spanish	ESC (2 S	27 40 50 83	1B 28 32 53
ISO 10: Swedish	ESC (3 S	27 40 51 83	1B 28 33 53
ISO 16: Portuguese	ESC (4 S	27 40 52 83	1B 28 34 53
ISO 84: Portuguese	ESC (5 S	27 40 53 83	1B 28 35 53
ISO 85: Spanish	ESC (6 S	27 40 54 83	1B 28 36 53
Windows 3.1 Latin5	ESC (5 T	27 40 53 84	1B 28 35 54
PC Turkish	ESC (9 T	27 40 57 84	1B 28 39 54
ISO 6: ASCII	ESC (0 U	27 40 48 85	1B 28 30 55
Legal	ESC (1 U	27 40 49 85	1B 28 31 55
ISO 2: IRV	ESC (2 U	27 40 50 85	1B 28 32 55
Roman 8	ESC (8 U	27 40 56 85	1B 28 38 55
Windows 3.0 Latin1	ESC (9 U	27 40 57 85	1B 28 39 55
PC-8	ESC (10 U	27 40 49 48 85	1B 28 31 30 55
PC-8 D/N	ESC (11 U	27 40 49 49 85	1B 28 31 31 55
PC 850	ESC (12 U	27 40 49 50 85	1B 28 31 32 55
Pi Font	ESC (15 U	27 40 49 53 85	1B 28 31 35 55
PC-852	ESC (17 U	27 40 49 55 85	1B 28 31 37 55
Windows 3.1 Latin1 Character Set (original)	ESC (19 U	27 40 49 57 85	1B 28 31 39 55
ROMAN 8	ESC (s 1 C	27 40 115 49 67	1B 28 73 31 43
US ASCII	ESC (s 2 C	27 40 115 50 67	1B 28 73 32 43
GERMAN	ESC (s 3 C	27 40 115 51 67	1B 28 73 33 43
UK ENGLISH	ESC (s 4 C	27 40 115 52 67	1B 28 73 34 43
FRENCH	ESC (s 5 C	27 40 115 53 67	1B 28 73 35 43
DUTCH	ESC (s 6 C	27 40 115 54 67	1B 28 73 36 43
ITALIAN	ESC (s 7 C	27 40 115 55 67	1B 28 73 37 43
S. SPANISH	ESC (s 8 C	27 40 115 56 67	1B 28 73 38 43
A. ENGLISH W.P.	ESC (s 9 C	27 40 115 57 67	1B 28 73 39 43
U.K. ASCII/2	ESC (s 10 C	27 40 115 49 48 67	1B 28 73 31 30 43
SYMBOL*	ESC (s 11 C	27 40 115 49 49 67	1B 28 73 31 31 43
INTERNATIONAL	ESC (s 12 C	27 40 115 49 50 67	1B 28 73 31 32 43
AMERICAN ENGLISH	ESC (s 13 C	27 40 115 49 51 67	1B 28 73 31 33 43
U.K. ASCII	ESC (s 14 C	27 40 115 49 52 67	1B 28 73 31 34 43
PORTUGUESE	ESC (s 15 C	27 40 115 49 53 67	1B 28 73 31 35 43
SWISS GERMAN	ESC (s 16 C	27 40 115 49 54 67	1B 28 73 31 36 43
AMERICAN SPANISH	ESC (s 17 C	27 40 115 49 55 67	1B 28 73 31 37 43
NORWEGIAN	ESC (s 18 C	27 40 115 49 56 67	1B 28 73 31 38 43
CANADIAN	ESC (s 19 C	27 40 115 49 57 67	1B 28 73 31 39 43
FINNISH/SWEDISH	ESC (s 20 C	27 40 115 50 48 67	1B 28 73 32 30 43
SOUTH AFRICA	ESC (s 21 C	27 40 115 50 49 67	1B 28 73 32 31 43
JAPANESE ENGLISH	ESC (s 37 C	27 40 115 51 55 67	1B 28 73 33 37 43

*The symbol character set is not available for Tennessee and Helsinki fonts.

USER'S GUIDE

Function	Command	Decimal	Hexadecimal
PC-8	ESC (s 25 C	27 40 115 50 53 67	1B 28 73 32 35 43
PC-8 D/N	ESC (s 23 C	27 40 115 50 51 67	1B 28 73 32 33 43
PC-850	ESC (s 26 C	27 40 115 50 54 67	1B 28 73 32 36 43
PC-860	ESC (s 27 C	27 40 115 50 55 67	1B 28 73 32 37 43
PC-863	ESC (s 28 C	27 40 115 50 56 67	1B 28 73 32 38 43
PC-865	ESC (s 29 C	27 40 115 50 57 67	1B 28 73 32 39 43
Fixed Pitch or P.S.			
Fixed	ESC (s 0 P	27 40 115 48 80	1B 28 73 30 50
P.S.	ESC (s 1 P	27 40 115 49 80	1B 28 73 31 50
Character Pitch Selection 1	ESC (s # H	27 40 115 ## 72	1B 28 73 ## 48
	(#: char./inch)		
Character Pitch Selection 2			
10 Pitch	ESC & k 0 S	27 38 107 48 83	1B 26 6B 30 53
16.6 Pitch	ESC & k 2 S	27 38 107 50 83	1B 26 6B 32 53
12 Pitch	ESC & k 4 S	27 38 107 52 83	1B 26 6B 34 53
Point Size	ESC (s # V	27 40 115 ## 86	1B 28 73 ## 56
	(#: point size)		
Italics or upright			
Italics	ESC (s 1 S	27 40 115 49 83	1B 28 73 31 53
Upright	ESC (s 0 S	27 40 115 48 83	1B 28 73 30 53
Condensed	ESC (s 4 S	27 40 115 52 83	1B 28 73 34 53
Condensed Italic	ESC (s 5 S	27 40 115 53 83	1B 28 73 35 53
Compressed (Extra Condensed)	ESC (s 8 S	27 40 115 56 83	1B 28 73 38 53
Expanded	ESC (s 24 S	27 40 115 50 52 83	1B 28 73 32 34 53
Outline	ESC (s 32 S	27 40 115 51 50 83	1B 28 73 33 32 53
Inline	ESC (s 64 S	27 40 115 54 52 83	1B 28 73 36 34 53
Shadowed	ESC (s 128 S	27 40 115 49 50 56 83	1B 28 73 31 32 38 53
Outline Shadowed	ESC (s 160 S	27 40 115 49 54 48 83	1B 28 73 31 36 30 53
Stroke Weight	ESC (s # B	27 40 115 ## 66	1B 28 73 ## 42
Ultra Thin	ESC (s-7B	27 40 115 2D 55 66	1B 28 73 45 37 42
Extra Thin	ESC (s-6B	27 40 115 2D 54 66	1B 28 73 45 36 42
Thin	ESC (s-5B	27 40 115 2D 53 66	1B 28 73 45 35 42
Extra Light	ESC (s-4B	27 40 115 2D 52 66	1B 28 73 45 34 42
Light	ESC (s-3B	27 40 115 2D 51 66	1B 28 73 45 33 42
Demi Light	ESC (s-2B	27 40 115 2D 50 66	1B 28 73 45 32 42
Semi Light	ESC (s-1B	27 40 115 2D 49 66	1B 28 73 45 31 42
Medium (Normal)	ESC (s 0 B	27 40 115 48 66	1B 28 73 30 42
Semi Bold	ESC (s 1 B	27 40 115 49 66	1B 28 73 31 42
Demi Bold	ESC (s 2 B	27 40 115 50 66	1B 28 73 32 42
Bold	ESC (s 3 B	27 40 115 51 66	1B 28 73 33 42
Extra Bold	ESC (s 4 B	27 40 115 52 66	1B 28 73 34 42
Black	ESC (s 5 B	27 40 115 53 66	1B 28 73 35 42
Extra Black	ESC (s 6 B	27 40 115 54 66	1B 28 73 36 42
Ultra Black	ESC (s 7 B	27 40 115 55 66	1B 28 73 37 42
Scalable Font Ratio (original)			
Set horizontal ratio	ESC CR ! # H	27 13 33 # 72	1B 0D 21 # 48
(#=0.25 to 3 step 0.01)			
Set vertical ratio	ESC CR ! # V	27 13 33 # 86	1B 0D 21 # 56
(#=0.25 to 3 step 0.01)			

Function	Command
Scalable Fonts	
Intellifont-compatible Fonts (##: point size)	
Brougham	ESC (s 0 p ## h 0 s 0 b 4 0 9 9 T
Brougham Bold	ESC (s 0 p ## h 0 s 3 b 4 0 9 9 T
Brougham Oblique	ESC (s 0 p ## h 1 s 0 b 4 0 9 9 T
Brougham BoldOblique	ESC (s 0 p ## h 1 s 3 b 4 0 9 9 T
Cleveland Condensed	ESC (s 1 p ## v 4 s 3 b 4 1 4 0 T
Connecticut	ESC (s 1 p ## v 1 s 0 b 4 1 1 6 T
Guatemala Antique	ESC (s 1 p ## v 0 s 0 b 4 1 9 7 T
Guatemala Italic	ESC (s 1 p ## v 0 s 3 b 4 1 9 7 T
Guatemala Bold	ESC (s 1 p ## v 1 s 0 b 4 1 9 7 T
Guatemala BoldItalic	ESC (s 1 p ## v 1 s 3 b 4 1 9 7 T
Maryland	ESC (s 1 p ## v 0 s 0 b 4 2 9 7 T
PC Tennessee Roman	ESC (s 1 p ## v 0 s 0 b 4 1 0 1 T
PC Tennessee Bold	ESC (s 1 p ## v 0 s 3 b 4 1 0 1 T
PC Tennessee Italic	ESC (s 1 p ## v 1 s 0 b 4 1 0 1 T
PC Tennessee BoldItalic	ESC (s 1 p ## v 1 s 3 b 4 1 0 1 T
Utah	ESC (s 1 p ## v 0 s 0 b 4 1 4 8 T
Utah Bold	ESC (s 1 p ## v 0 s 3 b 4 1 4 8 T
Utah Oblique	ESC (s 1 p ## v 1 s 0 b 4 1 4 8 T
Utah BoldOblique	ESC (s 1 p ## v 1 s 3 b 4 1 4 8 T
Bitmapped Fonts	
LetterGothic16.66	ESC (s 0 p 16.67 h 8.5 v 0 s 0 b 1 3 0 T
OCR-B	ESC (1 O ESC (s 0 p 10 h 12 v 0 s 0 b 1 1 0 T

CCITT G3/G4 (original command)

One of the unique features of the PCL mode of this printer is it supports CCITT G3/G4 type data compression format.

■ CCITT G3/G4 (Raster Graphic Mode 1152)

The printer's PCL mode supports CCITT G3/G4 type graphic data compression.

This format is popular in optical document storage area as this compression is effective to store black and white type pictures. Compression mode for CCITT G3/G4 is 1152 and the command becomes

ESC * b 1152 M.

As G3/G4 format does not have picture size/resolution information, the printer requires a header at the beginning of the picture data. The header size is 94 byte. Both the header and the picture data are transferred by one transfer graphics data command (ESC * b ### W). Normal PCL transfer graphics data command has a limitation of the data size and ### should not exceed 32767. Unlike other mode, mode 1152 is special and this mode does not have 32767 byte size limitation. Print model is not applied to this type of raster graphics.

The mode 1152 graphic data consists of the following data structure. The picture data follows the header.

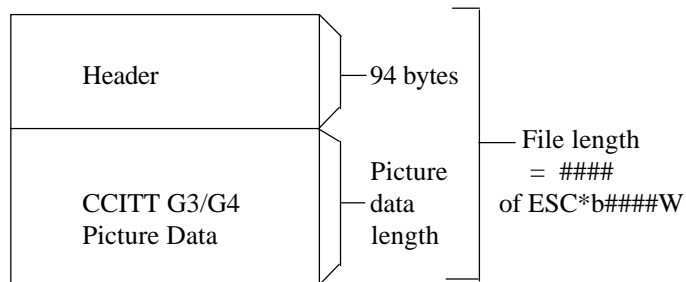

Header format is described on the next page. You have to specify mode 1152 by sending ESC *b1152M command for each graphic data transfer.

About CCITT G3/G4 data format, please refer to CCITT (THE INTERNATIONAL TELEGRAPH AND TELEPHONE CONSULTATIVE COMMITTEE) BLUE BOOK Volume VII.

Mode 1152 graphic data header data structure

Position	Data	Description
0-1	6E 6E	'nn' This is header ID.
2-3	0A 00	reserved (Header Version)
4-7	5E 00 00 00	Picture data start offset from header top
8-11	File Length	File length including 94 byte header. If file length is 65,536 byte, these 4 bytes become "00 00 01 00".
12-13	01 00	reserved
14-15	01 00	reserved
16-19	4A 00 00 00	reserved
20-21	compression	02 00: Fax MH format 03 00: Fax MR format 04 00: Fax G4 format
22-55	00...00	All zero
56-59	Picture Data Length	If picture data length is 65,442 (65,536 - 94) byte, these 4 bytes become "A2 FF 00 00".
60-61	01 00	bit/pixel
62-63	01 00	bit/pixel
64-65	Pixels/line	If picture dot width = 2400, these 2 bytes become "60 09".
66-67	Pixels/line	Same as 64-65
68-69	Lines/picture	If picture line count = 3100, these 2 bytes become "1C 0C".
70-71	Lines/picture	Same as 70-71
72-73	00 00	reserved
74-75	Photo metrics	00 00: data 0 = white 01 00: data 0 = black
76-77	02 00	reserved (Endian format)
78-79	Bit Fill Order	01 00: filled from MSB 02 00: filled from LSB
80-81	01 00	reserved
82-83	00 00	reserved (min. pixel value)
84-85	01 00	reserved (max pixel value)
86-87	horizontal resolution (200,300,400,600)	C8 00 00 00 : 200 dpi 2C 01 00 00 : 300 dpi 90 01 00 00 : 400 dpi 58 02 00 00 : 600 dpi 400 and 600 dpi are available when printer operates in 600 dpi.
88-89	vertical resolution (200,300,400,600)	C8 00 00 00 : 200 dpi 2C 01 00 00 : 300 dpi 90 01 00 00 : 400 dpi 58 02 00 00 : 600 dpi The printer accepts different values for vertical and horizontal resolutions. 400/600 dpi are available when printer operates in 600 dpi. 90-91
	02 00	reserved (resolution unit = inch)
92-93	00 00	reserved (error code)

HP-GL/2 Command Sets

Command	Mnemonic	Parameters
Dual Context Extensions		
ENTER PCL MODE	ESC % # A	0-Retain previous PCL cursor position and palette 1-Use current HP-GL/2 pen position and palette
RESET	ESC E	None
PRIMARY FONT	FI	Font_ID
SECONDARY FONT	FN	Font_ID
SCALABLE OR BITMAPPED FONTSSB		0-Scalable fonts only 1-Bitmapped fonts allowed
Palette Extensions		
TRANSPARENCY MODE	TR	0-Off (opaque) 1-On (transparent)
SCREENED VECTORS	SV	[screen_type [, shading [, index]]]
Vector Group		
ARC ABSOLUTE	AA	x_center, y_center, sweep_angle [, chord_angle];
ARC RELATIVE	AR	x_increment, y_increment, sweep_angle [, chord_angle];
ABSOLUTE ARC THREE POINT	AT	x_inter, y_inter, x_end, y_end [,chord_angle];
BEZIER ABSOLUTE	BZ	x1_control_pt, y1_control_pt x2_control_pt, y2_control_pt x3_control_pt, y3_control_pt [, params ... [, params]].
BEZIER RELATIVE	BR	x1_control_pt_increments, y1_control_pt_increments, x2_control_pt_increments, y2_control_pt_increments, x3_control_pt_increments, y3_control_pt_increments [, params ... [, params]];
ABSOLUTE	PA	[x, y ... [, x, y]]; PLOT
PLOT RELATIVE	PR	[x, y ... [, x, y]];
PEN DOWN	PD	[x, y ... [, x, y]];
PEN UP	PU	[x, y ... [, x, y]];
RELATIVE ARC THREE POINT	RT	x_incr_inter, y_incr_inter, x_incr_end, y_incr_end [, chord_angle];
POLYLINE ENCODED	PE	[flag [val] coord_pair ... [flag[val] coord_pair]];
Polygon Group		
CIRCLE	CI	radius [, chord_angle];
FILL RECTANGLE ABSOLUTE	RA	x_coordinate, y_coordinate;
FILL RECTANGLE RELATIVE	RR	x_increment, y_increment;
EDGE RECTANGLE ABSOLUTE	EA	x_coordinate, y_coordinate;
EDGE RECTANGLE RELATIVE	ER	x_increment, y_increment;
FILL WEDGE	WG	radius, start_angle, sweep_angle [, chord_angle];

Command	Mnemonic	Parameters
EDGE WEDGE	EW	radius, start_angle, sweep_angle [, chord_angle];
POLYGON MODE	PM	polygon_definition;
FILL POLYGON	FP	0 Odd/Even fill
EDGE POLYGON	EP	1 non-zero winding fill
Character Group		
SELECT STANDARD FONT	SS	
SELECT ALTERNATE FONT	SA	
ABSOLUTE DIRECTION	DI	[run, rise];
RELATIVE DIRECTION	DR	[run, rise];
ABSOLUTE CHARACTER SIZE	SI	[width, height];
RELATIVE CHARACTER SIZE	SR	[width, height];
CHARACTER SLANT	SL	[tangent_of_angle];
EXTRA SPACE	ES	[width [, height]]
STANDARD FONT DEFINITION	SD	[kind, value ... [, kind, value]];
ALTERNATE FONT DEFINITION	AD	[kind, value ... [, kind, value]];
CHARACTER FILL MODE	CF	[fill_mode [, edge_pen]];
LABEL ORIGIN	LO	[position];
LABEL	LB	[char ... [char]] 1 bterm
DEFINE LABEL TERMINATOR	DT	[1 bterm [, mode]];
CHARACTER PLOT	CP	[spaces, lines];
TRANSPARENT DATA	TD	[mode];
DEFINE VARIABLE TEXT PATH	DV	[path [, line]];
Line and Fill Attributes Group		
LINE TYPE	LT	[line_type [, pattern_length [, mode]]];
LINE ATTRIBUTES	LA	[kind, value ... [, kind, value]];
PEN WIDTH	PW	[width [, pen]];
PEN WIDTH UNIT SELECTION	WU	[type];
SELECT PEN	SP	[pen];
SYMBOL MODE	SM	[char];
FILL TYPE	FT	[fill_type [, option 1 [, option 2]]];
ANCHOR CORNER	AC	[x_coordinate, y_coordinate];
RASTER FILL DEFINITION	RF	[index, width, height, pen_nbr [, ... pen_nbr]];
USER DEFINED LINE TYPE	UL	[index [, gap 1 ... gap 20]];
Configuration and Status Group		
COMMENT	CO	
SCALE	SC	[x 1, x 2, y 1, y 2 [, type [, left, bottom]]];
		or
		[x 1, x factor, y 1, y factor, 2];
INPUT WINDOW	IW	[x L L, y L L, x U R, y U R];
INPUT P1 AND P2	IP	[p 1 x, p 1 y [, p 2 x, p 2 y]];
INPUT RELATIVE P1 AND P2	IR	[p 1 x, p 1 y [, p 2 x, p 2 y]];
DEFAULT VALUES	DF	
INITIALIZE	IN	
ROTATE COORDINATE SYSTEM	RO	[angle];

Printer Job Language Commands Syntax

Command	Function and Syntax	DEC.	HEX.
Syntax Rules			
[]	Brackets indicate optional parameters.		
< >	Indicates special characters and items		
Special Characters and Items			
<HT>	Horizontal Tab (element of white space)	09	09
<LF>	Line Feed (PJL command terminator)	10	0A
<CR>	Carriage Return (optional parameter)	13	0D
<SP>	Space (element of white space)	32	20
<ESC>	Escape (used only for UEL/SPJL)	27	1B
<FF>	Form Feed (terminator for multiple line reply)	12	0C
<WS>	White Space-<SP> or <HT> or combination of <SP> and <HT>		
<PC>	Printable Characters (character code 33 through 126, and 161 through 254)		
<Words>	Beginning with <PC>, and combination of <PC> and <WS>		
Printer Job Language Commands Syntax			
COMMENT	@PJL COMMENT <Words> [<CR>] <LF>		
DEFAULT	@PJL DEFAULT [LPARM: emulation] variable = value [<CR>] <LF>		
DINQUIRE	@PJL DINQUIRE [LPARM: emulation] variable [<CR>] <LF>		
Reply	@PJL DINQUIRE [LPARM: emulation] variable <CR> <LF> value <CR> <LF> <FF>		
ECHO	@PJL ECHO [<Words>] [<CR>] <LF>		
Reply	@PJL ECHO [<Words>] <CR> <LF> <FF>		
ENTER	@PJL ENTER LANGUAGE = emulation [<CR>] <LF>		
EOJ	@PJL EOJ [NAME = job name] [<CR>] <LF>		
INFO	@PJL INFO read only variable [<CR>] <LF>		
Reply	@PJL INFO read only variable <CR> <LF> [1 or more lines of printable characters or <WS> followed by <CR> <LF>] <FF>		
INITIALIZE	@PJL INITIALIZE [<CR>] <LF>		
INQUIRE	@PJL INQUIRE [LPARM: emulation] variable [<CR>] <LF>		
Reply	@PJL INQUIRE [LPARM: emulation] variable <CR> <LF> value <CR> <LF> <FF>		
JOB	@PJL JOB [NAME = "job name"] [START = first page] [END = last page] [<CR>] <LF>		
OPMSG	@PJL OPMSG DISPLAY = "message" [<CR>] <LF>		
RDYMSG	@PJL RDYMSG DISPLAY = "message" [<CR>] <LF>		
RESET	@PJL RESET [<CR>] <LF>		
SET	@PJL SET [LPARM: emulation] variable = value [<CR>] <LF>		
STMSG	@PJL STMSG DISPLAY = "message" [<CR>] <LF>		
Reply	@PJL STMSG DISPLAY = "message" <CR> <LF> key <CR> <LF> <FF>		
Exit Current Emulation/Start PJL (UEL/SPJL)	<ESC> % - 12345X		
USTATUS	@PJL USTATUS variable = value [<CR>] <LF>		
Reply	@PJL USTATUS variable <CR> <LF> [1 or more lines of printable characters or <WS> followed by <CR> <LF>] <FF>		
USTATUSOFF	@PJL USTATUSOFF [<CR>] <LF>		
(No Operation)	@PJL [<CR>] <LF>		

EPSON FX-850 Mode

Command name	Function	Sequence	Decimal	Hexadecimal
Null	Ignored	NUL	0	00
Bell	Ignored	BEL	7	07
Space	Moves the cursor one position to the right	SP	32	20
Backspace	Moves the cursor one position to the left	BS	8	08
Line Feed	Moves down one line	LF	10	0A
Form Feed	Ejects a page (if data has been printed on it)	FF	12	0C
Carriage Return	Moves cursor to left margin	CR	13	0D
Home Positioning	Moves the cursor to the home position	ESC <	27 60	1B 3C
Select Printer	Ignored	DC1	17	11
Deselect Printer	Ignored	DC3	19	13
Set MSB=0	Sets most significant bit to zero	ESC =	27 61	1B 3D
Set MSB=1	Sets most significant bit to one	ESC >	27 62	1B 3E
Cancel MSB Settings	Cancels MSB settings	ESC #	27 35	1B 23
Expand Printable Code Area	Allows characters 128 (d) through 159 (d) and 255 (d) to be printed	ESC 6	27 54	1B 36
Cancel Expanded Printable Code Area	Cancels printing of characters 128 (d) through 159 (d) and 255 (d)	ESC 7	27 55	1B 37
Expand Printable Code Area	Allows characters 0 (d) through 31 (d) and 128 (d) through 159 (d) to be printed	ESC I 1	27 73	49 1B 49 31
Cancel Expand Printable Code Area	Cancels printing of characters 0 (d) through 31 (d) and 129 (d) through 159 (d)	ESC I 0	27 73	48 1B 49 30
Change Emulation (original)	Changes the emulation of the printer. All data received so far will be printed and the page ejected. m is an ASCII code. m=E - Reset Epson Mode m=GL - HP-GL Mode m=H - HP LaserJet 4 Mode m=I - IBM Proprinter Mode	ESC CR m	27 13 m	1B 0D m
User Reset	Restore to User Settings (n=0 to 2)	ESC CR ! n R	27 13 33 n 82	1B 0D 21 n 52
Paper Input Control	Controls the paper input n=0 - Initialize Feeder Mode n=1 - Feed From MP Tray n=2 - Feed From Upper Cassette (Tray 1) n=3 - Feed From Lower Cassette (Tray 2) n=R - Eject Paper	ESC EM n	27 25 n	1B 19 n
Duplex/Simplex Print 33	1B 0D 21	Sets simplex or duplex print mode	ESC CR !	27 13
(available when duplex unit is installed) (original)	n=1 - Duplex & long edge binding n=2 - Duplex & short edge binding	n=0 - Simplex	n D	n 68 n 44
Page Side Selection (available when duplex unit is installed) (original)	Sets page side selection n=1 - Front side n=2 - Back side	ESC CR !	27 13 33	1B 0D 21 n S n 83 n 53
Initialize Printer	Initializes printer and clears print buffer (prints data)	ESC @	27 64	1B 40
Set Form Length	Sets page length in current line spacing (1≤n≤127)	ESC C n	27 67 n	1B 43 n
Set Left Margin	Sets left margin n characters from home position (range depends on type size and paper size)	ESC / n	27 108 n	1B 6C n

Command name	Function	Sequence	Decimal	Hexadecimal
Set Right Margin	Sets right margin n columns from the left margin (range depends on type size and paper size)		ESC Q n	27 81 n 1B 51 n
Set Skip-over Perforation	Sets bottom margin at the n-th line, counting from the bottom	ESC N n	27 78 n	1B 4E n
Cancel Skip-over Perforation	Cancels the setting of the bottom margin		ESC O	27 79 1B 4F
Set 1/6" Line Spacing		Line spacing is set to 1/6 inch	ESC 2	27 50 1B 32
Set 1/8" Line Spacing		Line spacing is set to 1/8 inch	ESC 0	27 48 1B 30
Set 7/72" Line Spacing		Line spacing is set to 7/72 inch	ESC 1	27 49 1B 31
Set n/72" Line Spacing		Line spacing is set to n/72 inch (0≤n≤85)	ESC A	
n	27 65 n	1B 41 n		
Set n/216" Line Spacing	Line spacing is set to n/216 inch (0≤n≤255)		ESC 3 n	27 51 n 1B 33 n
Perform n/216" Paper Feed	Advances paper (moves cursor) by n/216 inch	ESC J n	27 74 n	1B 4A n
Perform n/216" Reverse Paper Feed	Reverse feeds paper (moves cursor) by n/216 inch	ESC j n	27 106 n	1B 6A n
Set Horizontal Tab Stops	Sets up to 32 horizontal tab stops (terminated by a NUL)	ESC D n1 ... nk NUL	27 68 n1 ... nk 0	1B 44 n1 ... nk 00
Horizontal Tab	Moves to next horizontal tab	HT	9	09
Set Vertical Tab Stops	Sets up to 16 vertical tab stops (terminated by a NUL)	ESC b n1 ... nk NUL	27 98 n1 ... nk 0	1B 62 n1 ... nk 00
Vertical Tab	Moves to next vertical tab stop	VT	11	0B
Select VFU	Selects Vertical Format Unit	ESC / n	27 47 n	1B 2F n
Set Vertical Tab n1 ...	Sets up to 16 vertical tab stops in selected		ESC B n1 ...	27 66 n1 ... 1B 42
Stops (VFU Channel)	Vertical Format Unit (selected by previous command). Terminated by NUL	nk NUL	nk 0	nk 00
Set Absolute Print Position	Moves (n1 + n2 x 256)/60" from left margin	ESC \$ n1 n2	27 36 n1 n2	1B 24 n1 n2
Set Relative Print Position	Moves (n1 + n2 x 256)/120" from current position	ESC \ n1 n2	27 92 n1 n2	1B 5C n1 n2
Set Pica Pitch	Selects 10 cpi printing	ESC P	27 80	1B 50
Set Elite Pitch	Selects 12 cpi printing	ESC M	27 77	1B 4D
Set Proportional Spacing Mode	Selects proportional spacing mode and fonts (BS disabled)	ESC p 1	27 112 49	1B 70 31
Disable Proportional Spacing Mode	Disables proportional spacing mode	ESC p 0	27 112 48	1B 70 30
Set Condensed Mode	Sets condensed printing	SI or ESC SI	15 or 27 15	0F or 1B 0F
Cancel Condensed Mode	Cancels condensed printing mode	DC2	18	12
Set Emphasized Mode	Selects boldface printing	ESC E or ESC G	27 69 or 27 71	1B 45 or 1B 47
Cancel Emphasized Mode	ESC F cancels ESC E boldface and ESC H cancels ESC G boldface	ESC H	ESC F or 27 72	27 70 or 27 48 1B 46 or 1B
Set Enlarged Character Mode	Selects enlarged characters for one line only	SO or ESC SO or ESC W 1	14 or 27 14 or 27 87 49	0E or 1B 0E or 1B 57 31
Cancel Enlarged Character Mode	Cancels above settings (CAN cancels SO only, and DC4 cancels SO and ESC SO only)	DC4 or CAN or ESC W 0	20 or 24 or 27 87 48	14 or 18 or 1B 57 30

Command name	Function	Sequence	Decimal	Hexadecimal	
Set/Cancel Double-High Mode	Sets (n = 1) or cancels (n = 0) double-high mode		ESC w n	27 119 n	1B 77 n
Set Italic Print Mode	Selects italic printing	ESC 4	27 52	1B 34	
Cancel Italic Print Mode	Cancels italic printing	ESC 5	27 53	1B 35	
Set Super/Subscript Print Mode	Sets either superscript (n=0) or subscript (n=1) printing		ESC S n	27 83 n	1B 53 n
Cancel Super/Subscript Print Mode	Cancels effect superscript or subscript printing	ESC T	27 84	1B 54	
Set/Cancel Underline Print Mode	Sets (n=1) or cancels (n=0) underlined printing (including spaces)				ESC - n
45 n	1B 2D n				27
Select Justification	n=0: Left justify, n=1: Centering n=2: Right justify, n=3: Fully justify	ESC a n	27 97 n	1B 61 n	
Set Intercharacter Space	Adds n/120" space to each character	ESC SP n	27 32 n	1B 20 n	
Select Print Mode	Allows combinations of attributes to be added to following text	ESC ! n	27 33 n	1B 21 n	
Select Epson/IBM character set	Selects either Epson (n=0) or IBM (n=1) character set	ESC t n	27 116 n	1B 74 n	
Select International Character Set	Selects character set	ESC R n	27 82 n	1B 52 n	
Define Download Characters	Defines downloaded characters	ESC & NUL	27 38 0 n m	1B 26 00 n	
		n m a {data}	a {data}	m a {data}	
Select Download Character Mode	Selects either downloaded (n=1) or internal (n=0) character set	ESC % n	27 37 n	1B 25 n	
Copy ROM Characters to Download RAM	Copies internal character data to download RAM area	ESC : 0 0 0	27 58 48 48	1B 3A 30	
			48	30 30	
Select Bit Image Mode	Selects and prints bit image data	ESC * m n1	27 42 m n1	1B 2A m n1	
		n2 {data}	n2 {data}	n2 {data}	
Set 9-dot Bit Image Mode	Selects and prints "9-dot" bit image data	ESC ^ a n1	27 94 a n1	1B 5E a n1	
		n2 {data}	n2 {data}	n2 {data}	
Set Single-Density Bit Image Mode	Selects and prints single-density bit image data	ESC K n1 n2	27 75 n1 n2	1B 4B n1 n2	
		{data}	{data}	{data}	
Set Double-Density Bit Image Mode	Selects and prints double-density bit image data	ESC L n1 n2	27 76 n1 n2	1B 4C n1 n2	
		{data}	{data}	{data}	
Set Double-Speed Double-Density Bit Image Mode	Selects and prints "double-speed" double-density bit image data	ESC Y n1 n2	27 89 n1 n2	1B 59 n1 n2	
		{data}	{data}	{data}	
Set Quadruple-Density Bit Image Mode	Selects and prints quadruple-density bit image data	ESC Z n1 n2	27 90 n1 n2	1B 5A n1 n2	
		{data}	{data}	{data}	
Reassign Graphics Mode	Changes bit image density	ESC ? n m	27 63 n m	1B 3F n m	
Set Scalable Font Ratio (original)	Selects horizontal ratio (n=0.25 to 3 step 0.01)	ESC CR !	27 13 33	1B 0D 21	
		n H	n 72	n 48	
	Selects vertical ratio (n=0.25 to 3 step 0.01)	ESC CR !	27 13 33	1B 0D 21	
		n V	n 86	n 56	
Execute Card Data (original)	Execute saved card data	ESC CR !	27 13 33	1B 0D 21	
		n E	n 69	n 45	

IBM Proprinter XL Mode

Command name	Function	Sequence	Decimal	Hexadecimal
Null	Ignored	NUL	0	00
Bell	Ignored	BEL	7	07
Space	Moves the cursor one character to the right	SP	32	20
Backspace	Moves the cursor one character to the left	BS	8	08
Line Feed	Moves the cursor to the next line	LF	10	0A
Form Feed	Prints the data in the buffer and ejects the page (if the buffer is empty, this command is ignored)	FF	12	0C
Carriage Return	Moves the cursor to the left margin on the current line. If Auto LF has been set from the front panel or by software (ESC 5 1), the cursor will move down one line	CR	13	0D
Set/Cancel Auto Line Feed Mode	Sets (n=1) or cancels (n=0) auto line feed. Overrides the front panel setting	ESC 5 n	27 53 n	1B 35 n
Select Printer	Selects printer following deselection (ESC Q)	DC1	17	11
Deselect Printer	Ignored	DC3	19	13
Deselect Printer	Deselects printer, which will not accept data until a DC1 is received	ESC Q 2 2 ESC Q 3	27 81 50 50 27 51 51	1B 51 32 32 1B 51 33
Set Epson Emulation Mode	Selects Epson FX-850 emulation mode. All data in the buffer is printed and the page ejected	ESC @	27 64	1B 40
Change Emulation (original)	Changes the emulation of the printer. All data received so far will be printed and the page ejected. m is an ASCII code. m=E - Epson Mode m=GL - HP-GL Mode m=H - HP LaserJet 4 Mode m=I - Reset IBM Proprinter Mode	ESC CR m	27 13 m	1B 0D m
User Reset	Restore to User Settings (n=0 to 2)	ESC CR ! n R	27 13 33 n 82	1B 0D 21 n 52
Paper Input Control	Controls the paper input n=0 - Feed From Manual Feed Slot n=1 - Feed From MP Tray n=2 - Feed From Upper Cassette (Tray 1) n=3 - Feed From Lower Cassette (Tray 2) n=R - Eject Paper	ESC EM n	27 25 n	1B 19 n
Duplex/Simplex Print (available when duplex unit is installed) (original)	Sets simplex or duplex print mode 27 13 33 n=0 - Simplex n=1 - Duplex & long edge binding n=2 - Duplex & short edge binding	ESC CR !	27 13 33	1B 0D 21 n D n 68 n 44
Page Side Selection (available when duplex unit is installed) (original)	Sets page side selection n=1 - Front side n=2 - Back side	ESC CR !	27 13 33	1B 0D 21 n S n 83 n 53
Set Form Length	Sets form length to n lines at current spacing (1≤n≤255) Sets from length to n inches at current spacing (0≤n≤15)	ESC C n ESC C 0 n	27 67 n 27 67 48 n	1B 43 n 1B 43 30 n
Set Right and Left Margins	n1 is used to set the left margin, and n2 the right margin (1≤n1≤n2≤255)	ESC X n1 n2	27 88 n1 n2	1B 58 n1 n2
Set Skip-over Perforation	Sets bottom margin at n-th line, counting from the bottom (1≤n≤255)	ESC N n	27 78 n	1B 4E n

Command name	Function	Sequence	Decimal	Hexadecimal
Cancel Skip-over Perforation	Cancels the bottom margin setting	ESC O	27 79	1B 4F
Set 1/8" Line Spacing Mode	Sets line spacing to 1/8 inch	ESC 0	27 48	1B 30
Set 7/72" Line Spacing Mode	Sets line spacing to 7/72 inch	ESC 1	27 49	1B 31
Save n/72" Line Spacing Mode	Sets line spacing mode to n/72 inch (1≤n≤85). Activated by ESC 2 command	ESC A n	27 65 n	1B 41 n
Activate n/72" Line Spacing Mode set by ESC A	Activates line spacing mode set by ESC A		ESC 2	27 50 1B 32
Set n/216" Line Spacing	Sets line spacing to n/216 inch (1≤n≤255)		ESC 3 n	27 51 n 1B 33 n
Execute n/216" Line Spacing	Advances the cursor by n/216 inch	ESC J n	27 74 n	1B 4A n
Set Horizontal Tab Stops	Sets up to 28 horizontal tab stops (terminated by NUL)	ESC D n1 ... nk NUL	27 68 n1 ... nk NUL	1B 44 n1 ... nk NUL
Horizontal Tab	Advances to next horizontal tab (if none have been defined, default tab stops are set every 8 columns)	HT	9	09
Set Vertical Tab Stops	Sets up to 64 vertical tab stops (terminated by NUL)	ESC B n1 ... nk NUL	27 66 n1 ... nk NUL	1B 42 n1 ... nk NUL
Vertical Tab	Advances to next vertical tab stops (or LF if none have been defined)	VT	11	0B
Restore to Default Tab Settings	Clears any vertical tab stops, and sets default horizontal tab stops every 8 columns	ESC R	27 82	1B 52
Set Pica Pitch	Selects 10 cpi printing	DC2	18	12
Set Elite Pitch	Selects 12 cpi printing	ESC :	27 58	1B 3A
Set/Cancel Proportional Spacing Mode	Sets (n=1) or cancels (n=0) proportionally-spaced printing		ESC P n	27 80 n 1B 50 n
Set Condensed Character Mode	Selects condensed characters (canceled by DC2)	SI	15	0F
Set Emphasized Character Mode	Selects emphasized printing (canceled by ESC F)	ESC E	27 69	1B 45
Cancel Emphasized Character Mode	Cancels emphasized printing	ESC F	27 70	1B 46
Set Enlarged Character Mode	Selects enlarged characters for one line only	SO	14	0E
Cancel Enlarged Character Mode	Cancels one-line enlarged character printing	DC4 or CAN	20 or 24	14 or 18
Set/Cancel Enlarged Character Mode	Sets (n=1) or cancels (n=0) enlarged character printing. When n=0, SO enlarged printing will also be canceled	ESC W n	27 87 n	1B 57 n
Set Super/Subscript Print Mode	Sets superscript (n=0) or subscript (n=1) printing	ESC S n	27 83 n	1B 53 n
Cancel Super/Subscript Print Mode	Cancels superscript or subscript printing		ESC T	27 84 1B 54

Command name	Function	Sequence	Decimal	Hexadecimal
Set/Cancel Underline Print Mode	When n=1, subsequent characters (including spaces, but excluding horizontal tabs) are underlined. When n=0, this effect is canceled	ESC - n	27 45 n	1B 2D n
Set/Cancel Overline Print Mode	When n=1, subsequent characters (including spaces, but excluding horizontal tabs) are overlined. When n=0, this effect is canceled	ESC _ n	27 95 n	1B 5F n
Select Double-High/Double-Width Mode	Depending on the values of m3 and m4, double-height and/or double-width printing is enabled or disabled	ESC [@ 4 0 0 0 m3 m4	27 91 64 4 0 0 0 m3 m4	1B 5B 40 04 00 00 00 m3 m4
Select Character Set II	Allows printing of the symbols in Character Set II	ESC 6	27 54	1B 36
Select Character Set I	Allows printing of the symbols in Character Set I	ESC 7	27 55	1B 37
Select Characters from All Character Table	Allows (n1 + (n2 x 256)) characters to be printed from the All Characters Table. Control codes in the data are ignored	ESC \ n1 n2 {data}	27 92 n1 n2 {data}	1B 5C n1 n2 {data}
Select a Character from All Character Table	Prints one character (c) from the All Character Table	ESC ^ c	27 94 c	1B 5E c
Define 8-dot Download	Allows definition of user-defined characters	ESC = n1 n2 sp m a1 a2 {data}	27 61 n1 n2 32 m a1 a2 {data}	1B 3D n1 n2 20 m a1 a2 Characters {data}
Select Download Font	Selects font and print quality (n=0 or 2 - internal fonts, n=4 or 6 - downloaded fonts)	ESC I n	27 73 n	1B 49 n
Set Single-Density Bit Image Mode	Selects and prints single-density bit-image data	ESC K n1 n2 {data}	27 75 n1 n2 {data}	1B 4B n1 n2 {data}
Set Double-Density Bit Image Mode	Selects and prints double-density bit image data	ESC L n1 n2 {data}	27 76 n1 n2 {data}	1B 4C n1 n2 {data}
Set Double-Speed Double-Density Bit Image Mode	Selects and prints "double speed" double-density bit image data	ESC Y n1 n2 {data}	27 89 n1 n2 {data}	1B 59 n1 n2 {data}
Set Quadruple-Density Bit Image Mode	Selects and prints quadruple-density bit image data	ESC Z n1 n2 {data}	27 90 n1 n2 {data}	1B 5A n1 n2 {data}
Set Scalable Font Ratio (original)	Selects horizontal ratio (n=0.25 to 3 step 0.01) Selects vertical ratio (n=0.25 to 3 step 0.01)	ESC CR ! n H ESC CR ! n V	27 13 33 n 72 27 13 33 n 86	1B 0D 21 n 48 1B 0D 21 n 56
Execute Card Data (original)	Execute saved card data	ESC CR ! n E	27 13 33 n 69	1B 0D 21 n 45

HP-GL Mode

Command	Mnemonic	Parameters
Vector Group		
ARC ABSOLUTE	AA	x_center, y_center, sweep_angle [, chord_angle];
ARC RELATIVE	AR	x_increment, y_increment, sweep_angle [, chord_angle];
PLOT ABSOLUTE	PA	[x, y ... [, x, y]];
PLOT RELATIVE	PR	[x, y ... [, x, y]];
PEN DOWN	PD	[x, y ... [, x, y]];
PEN UP	PU	[x, y ... [, x, y]];
Polygon Group		
CIRCLE	CI	radius [, chord_angle];
SHADE RECTANGLE ABSOLUTE	RA	x_coordinate, y_coordinate;
SHADE RECTANGLE RELATIVE	RR	x_increment, y_increment;
EDGE RECTANGLE ABSOLUTE	EA	x_coordinate, y_coordinate;
EDGE RECTANGLE RELATIVE	ER	x_increment, y_increment;
SHADE WEDGE	WG	radius, start_angle, sweep_angle [, chord_angle];
EDGE WEDGE	EW	radius, start_angle, sweep_angle [, chord_angle];
Character Group		
SELECT STANDARD SET	SS	
SELECT ALTERNATE SET	SA	
ABSOLUTE DIRECTION	DI	[run, rise];
RELATIVE DIRECTION	DR	[run, rise];
ABSOLUTE CHARACTER SIZE	SI	[width, height];
RELATIVE CHARACTER SIZE	SR	[width, height];
CHARACTER SLANT	SL	[tangent_of_angle];
STANDARD SET DEFINITION	CS	[Designate_standard_character_set];
ALTERNATE SET DEFINITION	CA	[Designate_alternate_character_set];
LABEL	LB	[char ... [char]] l bterm
DEFINE LABEL TERMINATOR	DT	[l bterm];
CHARACTER PLOT	CP	[spaces, lines];
USER DEFINED CHARACTER	UC	[[pen_control], x_increment, y_increment [, ...] [, pen_control][, ...]];
Line and Fill Attributes Group		
LINE TYPE	LT	[line_type [, pattern_length]];
PEN WIDTH	PW	[width [, pen]];
SELECT PEN	SP	[pen];
SYMBOL MODE	SM	[char];
FILL TYPE	FT	[fill_type [, option 1 [, option 2]]];
TICK LENGTH	TL	[tick_p [, tick_n]];
X TICK	XT	
Y TICK	YT	
PEN THICKNESS	PT	[fill_line_interval];
Configuration and Status Group		
SCALE	SC	[x 1, x 2, y 1, y 2];
INPUT WINDOW	IW	[x L L, y L L, x U R, y U R];
INPUT P1 AND P2	IP	[p 1 x, p 1 y [, p 2 x, p 2 y]];
DEFAULT VALUES	DF	;
INITIALIZE	IN	;
ROTATE COORDINATE SYSTEM	RO	[angle];
PAGE OUTPUT	PG	[copy_number];

USER'S GUIDE

Function	Command	Decimal	Hexadecimal
Go to Other Emulations			
HP LaserJet 4	ESC CR H	27 13 72	1B 0D 48
IBM Proprinter XL	ESC CR I	27 13 73	1B 0D 49
EPSON FX-850	ESC CR E	27 13 69	1B 0D 45
User Reset			
Restore to User Settings	ESC CR ! n R n = 0 to 2	27 13 33 n 82	1B 0D 21 n 52
Factory Reset			
Restore to Factory Settings	ESC CR F D	27 13 70 68	1B 0D 46 44
Duplex/Simplex Print (available when duplex unit is installed) (original)			
Set Simplex	ESC CR ! 0 D	27 13 33 48 68	1B 0D 21 30 44
Set Duplex & long edge binding	ESC CR ! 1 D	27 13 33 49 68	1B 0D 21 31 44
Set Duplex & short edge binding	ESC CR ! 2 D	27 13 33 50 68	1B 0D 21 32 44
Page Side Selection (available when duplex unit is installed) (original)			
Set next side	ESC CR ! 0 S	27 13 33 48 83	1B 0D 21 30 53
Set front side	ESC CR ! 1 S	27 13 33 49 83	1B 0D 21 31 53
Set back side	ESC CR ! 2 S	27 13 33 50 83	1B 0D 21 32 53
Scalable Font Ratio (original)			
Set horizontal ratio (n=0.25 to 3 step 0.01)	ESC CR ! n H	27 13 33 n 72	1B 0D 21 n 48
Set vertical ratio (n=0.25 to 3 step 0.01)	ESC CR ! n V	27 13 33 n 86	1B 0D 21 n 56
Execute Card Data (original)			
Execute saved card data	ESC CR ! n E	27 13 33 n 69	1B 0D 21 n 45

Bar Code Control

The printer can print bar codes in the HP LaserJet 4, EPSON FX-850, and IBM Proprinter XL emulation modes.

Print Bar Codes or Expanded Characters

Code ESC i
Dec 27 105
Hex 1B 69

Format: ESC i n ... n \

Creates bar codes or expanded characters according to the segment of parameters “n ... n”. For further information about parameters, see the following “Definition of Parameters.” This command must end with the “\” code (5CH).

[Definition of Parameters]

This bar code command can have the following parameters in the parameter segment (n ... n). Since parameters are effective within the single command syntax ESC i n ... n \, they don't take effect in the subsequent bar code commands. If certain parameters are not specified, they take the default settings. The last parameter must be the bar code data start (“b” or “B”) or the expanded character data start (“I” or “L”). Other parameters can be specified in any sequence. The prefix of each parameter can be a lower-case or upper-case character: for example, “t0” or “T0”, “s3” or “S3”, etc.

■ Bar Code Mode

n = “t0” or “T0”	CODE 39 (default)
n = “t1” or “T1”	Interleaved 2 of 5
n = “t3” or “T3”	FIM (US-Post Net)
n = “t4” or “T4”	Post Net (US-Post Net)
n = “t5” or “T5”	EAN 8, EAN 13, or UPC A
n = “t6” or “T6”	UPC E
n = “t9” or “T9”	Codabar
n = “t12” or “T12”	Code 128 set A
n = “t13” or “T13”	Code 128 set B
n = “t14” or “T14”	Code 128 set C
n = “t130” or “T130”	ISBN (EAN)
n = “t131” or “T131”	ISBN (UPC-E)
n = “t132” or “T132”	EAN 128 set A
n = “t133” or “T133”	EAN 128 set B
n = “t134” or “T134”	EAN 128 set C

This parameter selects the bar code mode as above. When n is “t5” or “T5”, the bar code mode (EAN 8, EAN 13, or UPC A) varies according to the number of characters in the data.

■ Bar Code, Expanded Character, Line Block Drawing & Box Drawing

n = "s0" or "S0" 3 : 1 (default)
n = "s1" or "S1" 2 : 1
n = "s3" or "S3" 2.5 : 1

This parameter selects the bar code style as above. When the EAN 8, EAN 13, UPC-A, Code 128 or EAN 128 bar code mode is selected, this bar code style parameter is ignored.

Expanded Character

"S" 0 = White
1 = Black
2 = Vertical stripes
3 = Horizontal stripes
4 = Cross hatch

eg. "S" n1 n2
n1 = Background fill pattern
n2 = Foreground fill pattern

If "S" is followed by only one parameter, the parameter is a foreground fill pattern.

Line Block Drawing & Box Drawing

"S" 1 = Black
2 = Vertical stripes
3 = Horizontal stripes
4 = Cross hatch

■ Bar Code

n = "mnnn" or "Mnnn" (nnn = 0 ~ 32767)

This parameter specifies the bar code width. The unit of "nnn" is %.

■ Bar Code Human Readable Line On or Off

n = "r0" or "R0" Human readable line OFF

n = "r1" or "R1" Human readable line ON

Default: Human readable line ON

(1) "T5" or "t5"

(2) "T6" or "t6"

(3) "T130" or "t130"

(4) "T131" or "t131"

Default: Human readable line OFF

All others

This parameter specifies whether or not the printer prints the human readable line below the bar code. Human readable characters are always printed with OCR-B font of 10 pitch and all the current character style enhancements are masked. Note that the default setting is subject to the bar code mode selected by "t" or "T".

■ Quiet Zone

n = "onnn" or "Onnn" (nnn = 0 ~ 32767)

Quiet Zone is the space on both side of the bar codes. Its width can be specified using the units which are set by the "u" or "U" parameter. (For the description of "u" or "U" parameter, see the next section.) The default setting of Quiet Zone width is 1 inch.

■ Bar Code, Expanded Character Unit, Line Block Drawing & Box Drawing

n = "u0" or "U0" Millimeters (default)

n = "u1" or "U1" 1/10"

n = "u2" or "U2" 1/100"

n = "u3" or "U3" 1/12"

n = "u4" or "U4" 1/120"

n = "u5" or "U5" 1/10 Millimeters

n = "u6" or "U6" 1/300"

n = "u7" or "U7" 1/720"

This parameter specifies the measurement units of X-axis offset, Y-axis offset, and bar code height.

■ Bar Code, Expanded Character, Line Block Drawing & Box Drawing Offset in X-axis

n = "xnnn" or "Xnnn"

This parameter specifies the offset from the left margin in the "u"- or "U"-specified unit.

■ Bar Code & Expanded Character Offset in Y-axis

n = "ynnn" or "Ynnn"

This parameter specifies the downward offset from the current print position in the "u"- or "U"-specified unit.

■ Bar Code, Expanded Character, Line Block Drawing & Box Drawing Height

n = "hnnn", "Hnnn", "dnnn", or "Dnnn"

- (1) EAN13, EAN8, UPC-A, ISBN (EAN13, EAN8, UPC-A),
ISBN (UPC-E): 22 mm
- (2) UPC-E: 18 mm
- (3) Others: 12 mm

Expanded characters → 2.2 mm
(default)
Line Block Drawing & Box Drawing → 1 dot

This parameter specifies the height of bar codes or expanded characters as above. It can take the prefix "h", "H", "d", or "D". The height of bar codes is specified in the "u"- or "U"-specified unit. Note that the default setting of the bar code height (12 mm, 18 mm or 22 mm) is subject to the bar code mode selected by "t" or "T".

■ Expanded Character Width, Line Block Drawing & Box Drawing

n = "wnnn" or "Wnnn"

Expanded character → 1.2 mm
Line Block Drawing & Box Drawing → 1 dot

This parameter specifies the width of expanded characters as above.

■ Expanded Character Rotation

n = "a0" or "A1"	Upright (default)
n = "a1" or "A1"	Rotated 90 degrees
n = "a2" or "A2"	Upside down, rotated 180 degrees
n = "a3" or "A3"	Rotated 270 degrees

■ Bar Code Data Start

n = "b" or "B"

Data that follows "b" or "B" is read in as bar code data. Bar code data must end with the "\ " code (5CH), which also terminates this command. The acceptable bar code data is subject to the bar code mode selected by "t" or "T".

- When CODE 39 is selected with the parameter "t0" or "T0":

Forty three characters "0" to "9", "A" to "Z", "-", ".", " (space)", "\$", "/", "+", and "%" can be accepted as bar code data. Other characters cause data error. The number of characters for bar codes is not limited. The bar code data automatically starts and ends with an asterisk "*" (start character and stop character). If the received data has an asterisk "*" at its beginning or end, the asterisk is regarded as a start character or stop character.

- When Interleaved 2 of 5 is selected with the parameter "t1" or "T1":

Ten numerical characters "0" to "9" can be accepted as bar code data. Other characters cause data error. The number of characters for bar codes is not limited. Since this mode of bar codes require even characters, if the bar code data has odd characters, the zero character "0" is automatically added to the end of the bar code data.

- When FIM (US-Post Net) is selected with the parameter "t3" or "T3":

Characters "A" to "D" are valid and 1 digit of data can be printed. Uppercase and lowercase alphabet characters can be accepted.

- When Post Net (US-Post Net) is selected with the parameter "t4" or "T4":

Characters "0" to "9" can be data and it must be terminated by a check digit. "?" can be used in place of the check digit.

- When EAN 8, EAN 13, or UPC A is selected with the parameter "t5" or "T5":

Ten numerical characters "0" to "9" can be accepted as bar code data. The number of characters for bar codes is limited as follows.

EAN 8: Total 8 digits (7 digits + 1 check digit)

EAN 13: Total 13 digits (12 digits + 1 check digit)

UPC A: Total 12 digits (11 digits + 1 check digit)

A number of characters other than above causes data error and the bar code data is printed as normal print data. If the check digit is incorrect, the printer calculates the correct check digit automatically so that the correct bar code data will be printed. When EAN13 is selected, adding "+" and a 2-or 5-digit number after the data can create an add-on code.

- When UPC-E is selected with the parameter "t6" or "T6":

The numerical characters "0" to "9" can be accepted as bar code data.

(1) 8 digits Standard format. The first character must be "0" and the data must be terminated by a check digit.

Total 8 digits = "0" + 6 digits + 1 check digit.

(2) 6 digits The first character and the last check digit are removed from the 8 digit data.

*1: For 8 digits, "?" can be used in place of a check digit.

*2: Adding "+" and 2- or 5-digit number after the data creates an add-on code for all 6 and 8 digit formats.

- When Codabar is selected with the parameter "t9" or "T9":

Characters "0" to "9", "-", ". ", "\$", "/", "+", ":" can be printed.

Characters "A" to "D" can be printed as a start-stop code, which can be uppercase or lowercase. If there is no start-stop code, errors occur. A check digit cannot be added and using "?" causes errors.

- When Code 128 Set A, Set B, or Set C is selected with the parameter "t12" or "T12," "t13" or "T13," or "t14" or "T14" respectively:

Code 128 sets A, B and C are individually selectable. Set A encodes characters Hex 00 ... 5F. Set B encodes characters Hex 20 ... 7F. Set C encodes numeric pairs 00 ... 99. Switching is allowed between the code sets by sending %A, %B, or %C. FNC 1, 2, 3, and 4 are produced with %1, %2, %3, and %4. The SHIFT code, %S, allows temporary switching (for 1 character only) from set A to set B and vice versa. The "%" character can be encoded by sending it twice.

- When ISBN (EAN) is selected with the parameter “t130” or “T130”:

Same rules apply as for “t5” or “T5”

- When ISBN (UPC-E) is selected with the parameter “t131” or “T131”:

Same rules apply as for “t6” or “T6”

- When EAN 128 set A, set B or set C is selected with the parameter “t132” or “T132”, “t133” or “T133” or “t134” or “T134” respectively:

Same rules apply as for “t12” or “T12”, “t13” or “T13”, or “t14” or “T14”.

■ Box Drawing

ESC i ... E (or e)

“E” or “e” is a terminator.

■ Line Block Drawing

ESC i ... V (or v)

“V” or “v” is a terminator.

■ Expanded Character Data Start

n = “l” or “L”

Data that follows “l” or “L” is read in as expanded character data (or labeling data). Expanded character data must end with the “ \ ” code (5CH), which also terminates this command.

[Example Program Listings]

```
WIDTH "LPT1:",255

'CODE 39
LPRINT CHR$(27);"it0r1s0o0x00y00bCODE39?\";

'Interleaved 2 of 5
LPRINT CHR$(27);"it1r1s0o0x00y20b123456?\";

'FIM
```

USER'S GUIDE

```
LPRINT CHR$(27);"it3r1o0x00y40bA\";

'Post Net
LPRINT CHR$(27);"it4r1o0x00y60b1234567890?\\";

'EAN-8
LPRINT CHR$(27);"it5r1o0x00y70b1234567?\\";

'UPC-A
LPRINT CHR$(27);"it5r1o0x50y70b12345678901?\\";

'EAN-13
LPRINT CHR$(27);"it5r1o0x100y70b123456789012?\\";

'UPC-E
LPRINT CHR$(27);"it6r1o0x150y70b0123456?\\";

'Codabar
LPRINT CHR$(27);"it9r1s0o0x00y100bA123456A\";

'Code 128 set A
LPRINT CHR$(27);"it12r1o0x00y120bCODE128A12345?\\";

'Code 128 set B
LPRINT CHR$(27);"it13r1o0x00y140bCODE128B12345?\\";

'Code 128 set C
LPRINT CHR$(27);"it14r1o0x00y160b";CHR$(1);CHR$(2);"?\";

'ISBN(EAN)
LPRINTCHR$(27);"it130r1o0x00y180b123456789012?+12345\";

'EAN 128 set A
LPRINT CHR$(27);"it132r1o0x00y210b1234567890?\\";

LPRINT CHR$(12)
END
```

INDEX

▼ (DOWN) switch: 4-6

▲ (UP) switch: 4-6

A

adjustment knob for face up/down print delivery: 2-3

adjustment lever: 2-13

ALARM lamp: 4-4

angle of control panel: 3-7

anti-static teeth: 6-3

application software: 3-1

AUTO CR: 4-19

auto form feed: 4-38

AUTO LF: 4-19

AUTO MASK: 4-19

auto mode: 4-19

AUTO SKIP: 4-19

AUTO WRAP: 4-19

automatic emulation selection: 3-3

automatic interface selection: 3-5, 4-15

B

bar codes: 1-7, Appendix-59

baud rate: 4-17

bi-directional parallel

communications: 4-16

bi-directional parallel interface

connector: 2-3

bitmapped font: Appendix (printed)

bottom margin: 4-21

C

card operation: 4-29

CCITT: 1-7, Appendix-46

character set: 4-25, 4-51, 4-52, 4-55, Appendix-14

character sets in HP-GL emulation mode: 4-26

code table: 4-49, 4-53

code type: 4-17

commands: Appendix-34

communications parameters: 4-16

computer: 2-18

continue mode: 4-40

CONTINUE switch: 4-58

control panel: 2-3, 3-7

COPY switch: 4-72

cut sheet paper size: 4-21

D

data compression: Appendix-46

DATA lamp: 4-4

data terminal ready: 4-17

demonstration pattern: 4-81

display: 4-1

download font: 4-35

drum shutter: 2-7

DTR: 4-17

duplex mode: 4-70

duplex printing: 4-70

duplex unit: 1-9, 3-11, 5-10

E

ECONOMY switch: 4-64

emulation: 1-5

emulation mode: 3-1, 4-60

EMULATION switch: 4-60

envelope: 3-13

EPSON FX-850 mode: 4-63

ER: 4-17

error message: 7-3

error mode: 4-40

error recovery: 4-40

expansion memory: 5-6

F

face down print delivery: 3-17

face down print delivery tray: 2-3

face up print delivery: 3-17

USER'S GUIDE

factory settings: 3-10, 4-74
FEEDER switch: 4-65
fixing roller: 7-9
flash memory card: 1-9, 5-2
flash operation: 4-30
floppy disk: 1-3
fonts: 1-6, 4-54
font card: 5-2
font cartridge: 1-9, 5-2
font cartridge slot: 2-3
font/IC card slot: 2-3
font ID number: 5-5
font list: 4-82
font size: 4-48, 4-52
font source: 4-46, 4-50
font style: 4-47, 4-51
FONT switch: 4-44
form feed: 4-56
form feed suppress: 4-39
FORM FEED switch: 4-56
fuser: 6-6

G

G3/G4: 1-7
G3/G4 format: Appendix-46
graphics mode: 4-24

H

HDD card: 1-9, 5-2
hex dump mode: 4-83
high speed parallel communications: 4-16
HP-GL mode: 4-63
HP LaserJet 4 mode: 4-62
HP mode: 4-62

I

IBM Proprinter XL mode: 4-63
input buffer: 4-41
interface: 1-5
interface mode: 4-15

K

KEEP PCL function: 4-61

L

lamps: 4-4
landscape: 4-18
language: 3-8
LaserJet 4 mode: 4-62
left margin: 4-21
left side cover: 5-7
line feed pitch: 4-23
line spacing: 4-23
lines/page: 4-23
lines per page: 4-21
list of optional fonts: 4-80
list of panel switch settings: 4-80
list of permanent download fonts: 4-80
list of resident fonts: 4-80
lock panel: 4-38
lock your settings: 1-7
lower paper cassette: 3-11
lower tray unit: 1-9, 5-1

M

macro: 4-33
manual feed: 3-16
manual feed mode: 4-68
margin: 4-22
media type: 4-69
memory: 1-6, 5-6
memory modules: 1-9
MODE switch: 4-7
modular jack for options: 2-3
MP FIRST mode: 4-67
MP tray setting: 4-68
multi-purpose tray: 2-3, 2-15, 3-11

N

network mode: 4-37
NORMAL mode: 3-9, 4-5
number of copies: 4-72
number of printed pages: 4-43

O

off-line: 4-5
on-line: 4-5
ON LINE lamp: 4-4
operator call message: 7-1
optional fonts: 5-4
optional interface: 4-17

options: 1-9
orientation: 4-18

P

page format mode: 4-21
page protection: 4-28
paper access cover: 6-7, 7-10
paper capacity: 3-12
paper cassette: 1-5, 2-11, 3-15
paper exit: 7-7
paper feed method: 4-66
paper guide: 6-7
PAPER IN setting: 4-69
paper jam: 7-6
paper path selector guide: 3-17
paper size: 3-12
paper source: 3-12, 4-66
paper type: 3-12
paper width guide: 2-15
parallel interface: 1-5, 4-16
parallel interface port: 2-18
parity: 4-17
pass number: 4-38
PCMCIA-compatible flash memory
 card: 1-8
pen setting: 4-24
pen size: 4-24
portrait: 4-18
power cord: 2-19
power cord connector: 2-3
power save mode: 4-64
power saving mode: 1-7
power switch: 2-3, 2-20
primary font: 4-45
print density: 4-41
print start position: 4-21
printer driver: 3-1
printer emulation: 3-1
printer settings: 3-10, 4-81
printer status message: 4-2
printer test: 4-81
protective parts: 2-6

Q

quick exit switch: 4-6

R

READY lamp: 4-4
rear access cover: 2-3, 7-8
rear paper slit: 3-17
reprint: 1-8, 4-56
reset mode: 4-73
RESET switch: 4-73
resident fonts: Appendix (printed)
resolution: 1-4, 4-27
resolution mode: 4-26
right margin: 4-21
robust Xon: 4-17
RS-232C interface: 1-5
RS-232C serial interface connector: 2-3

S

secondary font: 4-45
SEL switch: 4-5
self-diagnosis: 2-20
serial interface: 1-5, 4-16
serial interface port: 2-18
service call message: 7-5
SET switch: 4-6
shades of gray: 1-4, 4-24
SHIFT mode: 3-9
SHIFT switch: 4-59
side paper stop: 2-13
SIMM: 5-8
simplex printing: 4-70
single in-line memory modules
 (SIMMs): 5-6
sizes of paper: 3-11
sleep: 4-64
sliding guide: 2-14
slot: 5-3
software: 3-1
spacers: 2-6
stop bit: 4-17
switch: 3-9
symbol set: 4-55, Appendix-14

T

table print: 4-49, 4-53
technical reference manual: 1-9
test mode: 4-80
test pattern: 4-81
TEST switch: 4-80

USER'S GUIDE

time out for the auto interface
 selection: 4-15
time out for the automatic emulation
 change: 4-60
time out for the power save mode: 4-64
toner cartridge: 1-4, 2-2, 2-7, 6-1
toner empty: 6-1
toner low: 4-40
top cover: 2-3, 2-5
top margin: 4-21
transfer guide: 6-7
transfer roller: 6-3
tray 1: 3-16
tray 2: 3-16

U

upper paper cassette: 2-3, 3-11
user settings: 3-10, 4-42

W

wait time: 4-39
Windows: 1-7

X

X offset: 4-21
Xon/Xoff: 4-17

Y

Y offset: 4-21

(For USA & CANADA Only)

For technical and operational assistance, please call:

In USA	1-800-276-7746 (outside California) 714-859-9700 (within California)
In Canada	1-800-361-6466

If you have comments or suggestions, please write us at:

In USA	Printer Customer Support Brother International Corporation 15 Musick Irvine, CA 92718
In Canada	Brother International Corporation, Ltd. 1, Rue Hôtel De Ville Dollard-des-Ormeaux P.Q. Canada H9B3H6

BBS

For downloading drivers from our Bulletin Board Service, call 1-714-859-2610. Please logon to our BBS with your first name, last name and a four digit number for your password. Our BBS supports modem speeds up to 14,400, 8 bits no parity, 1 stop bit.

DEALERS/SERVICE CENTERS

For the name of an authorized dealer or service center, call 1-800-284-4357.

brother[®]

UH2686001 (B)
Printed in Japan