

# Chinon CE-3

## Illustrated Guide

This is the full text and images from the manual.  
This may take 3 full minutes for all images to appear. If they do not all appear,  
try clicking the browser "refresh" or "reload button".

This manual is for reference and historical purposes, all rights reserved.

This page is copyright© by mike@butkus.org, M. Butkus, N.J.

This page may not be sold or distributed without the expressed permission of the producer

I have no connection with Chinon Co., Japan

**If you find this manual useful, how about a donation of \$3 to: M. Butkus, 29 Lake Ave., High Bridge, NJ 08829-1701 and send your e-mail address so I can thank you.**

**Most other places would charge you \$7.50 for a electronic copy or \$18.00 for a hard to read Xerox copy.**

**This will allow me to continue to buy new manuals and pay their shipping costs. It'll make you feel better, won't it?**

If you use Pay Pal or wish to use your credit card, click on the secure site below.

[Back to main camera manual page](#)



# CHINON

## CE-3 MEMOTRON

COMPACT 35mm  
ELECTRONIC  
SLR  
CAMERA

ILLUSTRATED GUIDE

[www.butkus.org](http://www.butkus.org)



# CHINON

## CE-3 MEMOTRON

COMPACT 35mm  
ELECTRONIC  
SLR  
CAMERA

[www.butkus.org](http://www.butkus.org)  
INSTRUCTION MANUAL



英  
ENGLISH

### NOMENCLATURE

(Please refer to figures A & B in [Illustrated Guide](#).)

1. ASA / DIN Selection pin

2. Film Rewind knob and back opening knob
3. Film Speed Dial (ASA / DIN) Exposure Compensation dial
4. Viewfinder Blind Lever
5. Accessory Shoe (hot shoe)
6. Frame Counter
- 7: Shoulder strap eyelet...
8. Shutter release button and lock lever
9. Film advance lever

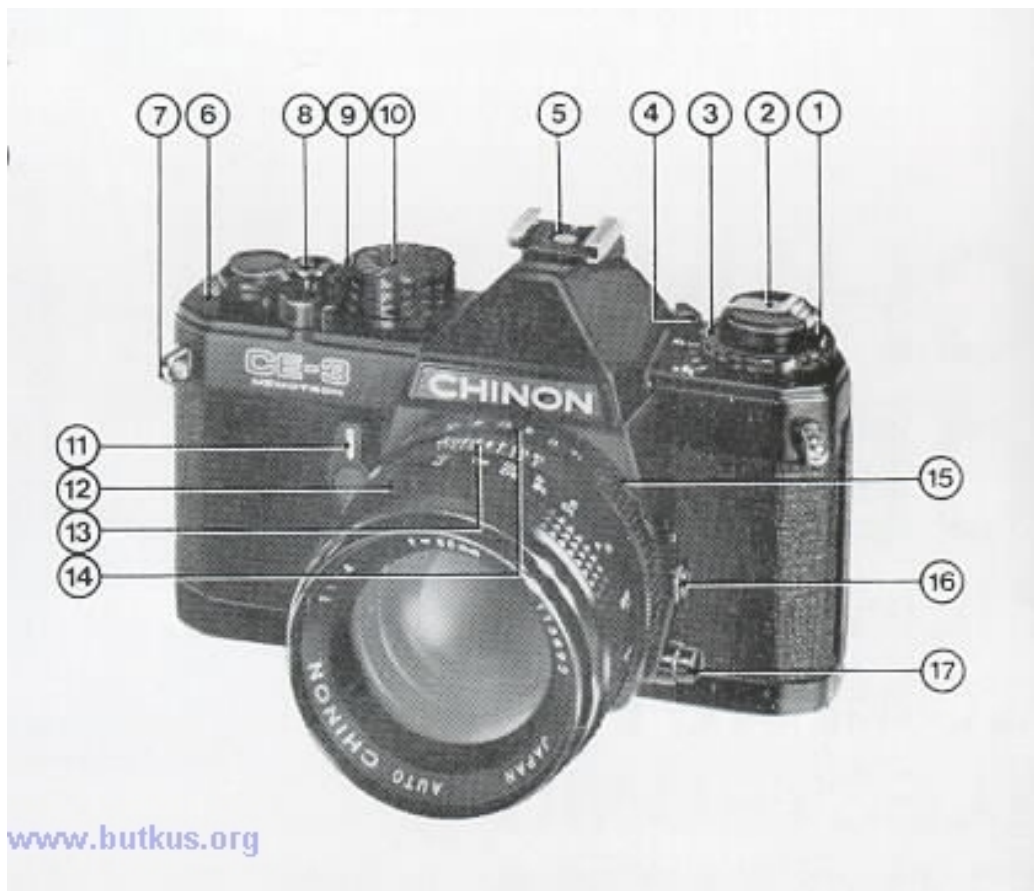

10. Shutter Speed dial

11. Self Timer lever
12. Focusing ring
13. Depth of Field Scale
14. Aperture ring

15. Auto / Manual lever

16. X sync socket

17. Exposure memory button

18. Film Chamber

19. Battery test green lamp (ICED)

20. Viewfinder eyepiece

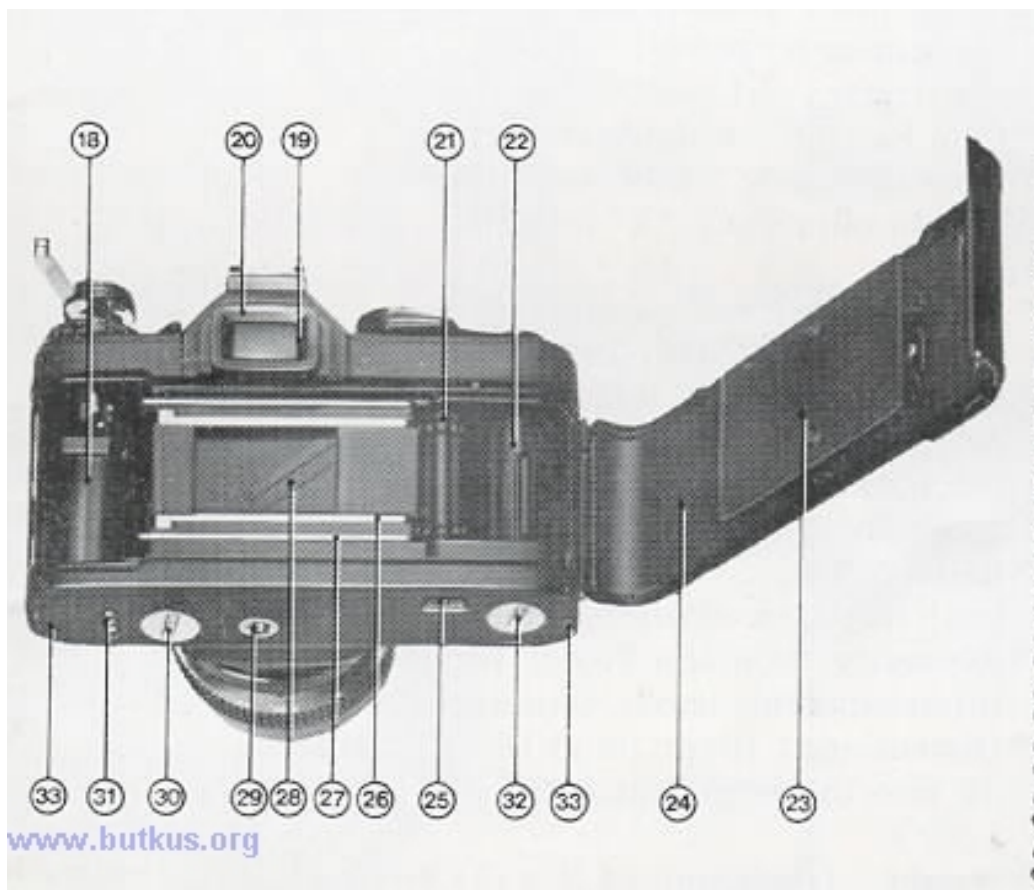

21. Sprocket teeth

22. Take up spool

23. Film pressure plate

24. Camera back

25. Rewind button

26. Film rail
27. Film guide rail
28. Seiko Electronic stepless shutter
29. Tripod socket
30. Battery chamber cover
31. Power Winder Electronic contacts
32. Power Winder Coupling cover
33. Power Winder guide pin receptacle



## SPECIFICATIONS

- \* **Type:** An automatic SLR (Single lens reflex) compact camera with aperture priority exposure system (AK) and Seiko metal electromagnetic shutter
- \* **Picture Size:** 24 x 36 mm...
- \* **Film:** 35 mm cartridge film
- \* **Lens Mount:** Pentax/Praktica M-42 Mount
- \* **Viewfinder Visibility:** 95% of negative size
- \* **Mirror:** Quick return, shockless system

\***Shutter:** Seiko MFC-ES (electromagnetic metal shutter, vertical path)

\***Shutter Speeds:** Auto: 4 sec. ~ 1/100 sec. (stepless)

**Manual:** "B", "X", 4 sec. ~ 1/1000 sec.

**Mechanical:** Shutter operation at "X" (1/100 sec.)

\* **Exposure Meter :** TTL, center weighted measuring system employing two silicon blue cells, Automatic exposure range of EV-1 ~ +18 at ASA 100 F/1.4

\* **ASA Range:** 25 -3200 (DIN 15 -36)

\* **Film Wind:** Single stroke in an arc of 135° with 20° stand off

\* **Film Counter :** Automatically indicates number of exposures and resets to zero when the camera is opened.

\* **Self Timer:** 7-12 seconds

\* **Film Rewind:** Folding crank type

\* **Accessory Shoe:** Built-in hot shoe

\* **Synchronization:** "X" terminal (X = 1/100 sec.)

\* **Power Source:** Two silver oxide G-13 type batteries (Eveready S-76 or equivalent) ...

\* **Viewfinder Blind:** Built-in viewfinder blind to prevent extraneous light from affecting the meter reading when the camera is used away from the eye.

\***Battery Test:** Indication by green signal lamp (LED) in viewfinder frame

\***Accessory:** Chinon Power Winder, Chinon Interchangeable lenses, various accessories

\***Dimensions:** (Body only) 140.50 mm (w) x 88 mm (h) x 50 mm (d) (5.53" x 3.46" x 1.96")

\***Weight:** (Body only) 620 g (21.86 oz.)

**Click on the links below to see the following illustrations**

[1. Installing the battery \(C\)](#)

[2. Load the camera](#)

[3. Set ASA film speed](#)

[4. Set the shutter speed dial to "Auto"](#)

[5. Select the lens opening](#)

[6. Focus the subject](#)

[7. Depress the shutter release button](#)



### **Installing the Batteries**

1. Using a coin, unlock the battery chamber cover by turning it counterclockwise.
2. Place the two 1.5V silver oxide G-13 type batteries (Eveready S-76 or equivalent) with the minus (-) side facing upwards ([Fig. 1](#)).
3. Replace the battery chamber cover by turning fully clockwise ([Fig. 2](#)).

**NOTE: CLEAN THE BATTERIES WITH A DRY CLOTH OR PAPER BEFORE INSERTING AND THEREAFTER AT REGULAR INTERVALS. MAKE SURE THAT THE BATTERIES ARE INSERTED CORRECTLY, i.e. CHECK POLARITY. THE SHUTTER WILL OPERATE ONLY WHEN BATTERIES ARE INSTALLED, EXCEPT FOR THE "X" (1/100 sec.) AND "B", POSITION.**

### **Testing the Batteries**

Test the batteries when:

- New batteries are installed.
- The camera has not been used for a long period of time.
- The camera is being used continuously for many hours.

To test the batteries, set the shutter speed dial to the "Auto" position ([Fig. 3](#)), and press the shutter release button half way. If the batteries are in good condition, the green lamp in the viewfinder frame will go on. When the green lamp does not go on, replace the batteries ([Fig. 4](#)).

**NOTE: EVERY TIME A PHOTOGRAPH IS TAKEN IN THE AUTO MODE, THE GREEN LAMP SHOULD GO ON, INDICATING THAT THE BATTERIES ARE STILL IN GOOD CONDITION. WHEN THE INDICATOR LAMP FAILS TO GO ON, REPLACE THE BATTERIES AT ONCE.**

## **LOADING THE CAMERA:**

Use 20 or 36 exposure 35mm film.

1. Pull out the film rewind knob until the camera back is released ([Fig. 5](#)), then swing the camera back fully open.
2. Keep the film rewind knob pulled all the way out, insert the film cartridge into the film chamber with the protruding end towards the base of the camera. Push in the film rewind knob ([Fig. 6](#)).

It may be found necessary to turn the knob slightly so that the rewind shaft engages the film cartridge spool. Insert the trimmed end of the film into the slot of the take-up spool. Holding the film lightly down on to the transport sprockets, operate the film advance lever. Having checked that the upper and lower film perforations have engaged the transport sprockets, close the camera back firmly ([Fig. 7](#)).

## **USING THE MEMO HOLDER:**

Your Chinon CE-3 Memotron compact SLR has a built-in memo holder feature. To utilize the memo holder feature simply cut off the top of the film box and insert it into the memo holder located on the back cover of your camera SO that you can quickly and easily identify the type of film and ASA speed used in the camera. Your calling card can also be inserted into the memo holder.

## **ADVANCING THE FILM:**

To make sure-- the film has been loaded properly, operate the film advance lever through a full stroke ([Fig. 8](#)). Now turn the rewind knob clockwise until resistance is felt. Do not force it. Keep observing the film rewind knob; it should turn counterclockwise every time the film is advanced.

Operate the film advance lever and shutter release until figure "1" is opposite the pointer in the frame counter window. The camera is now ready for the first exposure ([Fig. 9](#)) .---

**NOTE: WHEN THE SHUTTER RELEASE LOCK LEVER IS ENGAGED, ([Fig. 10](#)) THE SHUTTER CANNOT BE RELEASED. TURN THE LEVER TO THE LEFT TO UNLOCK ([Fig. 11](#)).**

**IMPORTANT NOTE: SET THE SHUTTER SPEED DIAL TO THE ~X" OR "MANUALS SPEED POSITION WHEN MAKING TWO BLANK EXPOSURES TO DISPOSE OF THE FIRST FEW INCHES OF FILM WHICH WERE EXPOSED DURING LOADING, HOWEVER, DO NOT SET THE SHUTTER SPEED DIAL TO THE AUTO POSITION, IF YOU SHOULD DEPRESS THE SHUTTER RELEASE BUTTON IN THE AUTO POSITION THE SHUTTER WILL REMAIN OPEN FOR A LONG PERIOD OF TIME (TIME EXPOSURE) AND THE FILM WILL NOT ADVANCE. WHEN**

**THE FILM COUNTER INDICATES YOU ARE READY TO TAKE THE FIRST EXPOSURE, BE SURE TO RETURN THE SHUTTER SPEED TO THE "AUTO" POSITION.**

## **FILM SPEED SETTING:**

The ASA / DIN speed of the film is indicated on the film box or in the instruction sheet packed with the film. Select the desired ASA / DID speed by turning the ASA selection pin until the appropriate ASA



number appears in the ASA dial window ([Fig. 12](#)) and then align the ASA/DIN number with the white index line on the camera top cover by turning the ASA/DIN ring.

### **THE SHUTTER SPEED SETTING:**

Your Chinon C~3 Memotron camera is equipped with an electro magnetically controlled Seiko stepless metal shutter for either automatic or manual exposure control. To set the camera for automatic shutter speed selection, rotate the shutter speed dial until the "Auto" mark is opposite the index line on the camera body ([Fig. 13](#)). To set it for manual exposure control, turn the shutter speed dial until the desired shutter speed is lined up with the index mark on the camera body.

### **THE APERTURE SETTING:**

The aperture is set in the usual manner by rotating the lens diaphragm ring until the required F-stop is set against the red diamond index mark on the lens barrel ([Fig. 14, 15](#)). With the shutter speed dial set at "Auto", the electronic metering system will set the corresponding shutter speed to ensure correct exposure of the film.

### **FOCUSING:**

Your Chinon CE-3 Memotron has three methods of focusing: split image, microprism, and scale focusing. Set the auto / manual control on the lens to the "Auto" position ([Fig. 16](#)). Observing the subject through the viewfinder turn the focusing ring on the lens until the upper and lower split images in the microprism are coincident in the center of the viewfinder ([Fig. 17, 18](#)). The focus can also be adjusted by the microprism which surrounds the microprism disk by turning the focusing ring on the lens back and forth until the image is perfectly sharp. This procedure ensures without a doubt that the image is at its sharpest setting.

### **Scale Focusing:**

You may also focus by utilizing the engraved distance scale on the lens. Estimate or measure the camera to subject distance in feet or meters then set the focusing ring to the appropriate setting ([Fig. 19](#)).

### **AUTOMATIC EXPOSURE:**

The meter on / off switch is incorporated in the winding mechanism. It is therefore necessary to advance the film advance lever before proceeding. Set the shutter speed dial to "Auto" ([Fig. 20](#)) and select the aperture according to your purpose for shooting the picture. Focus the subject. Depress the shutter release button slowly and smoothly. When the shutter release button is half way depressed, the exposure meter needle will indicate the correct shutter speed figure according to the light value which corresponds to the chosen aperture value ([Fig. 21](#)). Further depression of the shutter release button will release the shutter at the shutter speed indicated in the viewfinder.

### **EXPOSURE METER NEEDLE:**

**1. Over Exposure:** Over exposure will be indicated by the meter needle moving into the upper striped area of the viewfinder scale ([Fig. 22](#)). Should this occur the lens aperture must be reduced until the needle enters the shutter speed scale. If the needle will not enter the scale a neutral density filter must be used.

**2. Correct Exposure:** The exposure meter needle stays within the scale (arrow marked) correct exposure will result. It will be found when handling the camera that automatic shutter speed selection is a function of the aperture and the ASA values chosen.

As the lens aperture is altered the shutter speed will alter accordingly. Therefore, if the camera selects a speed that is considered unsuitable for the subject to be photographed, change the aperture until a suitable shutter speed is selected. **Should the meter needle move below 1/ 30 sec. then the use of a tripod is recommended, providing that a larger aperture cannot be set** ([Fig. 23](#)).

**3. Under Exposure:** Under exposure will be indicated by the meter needle moving into the lower striped area of the viewfinder shutter speed scale ([Fig. 24](#)). To compensate open up the lens aperture until the needle moves back onto the scale. Should the needle still not reenter the scale additional lighting or an electronic flash unit must be used.

### **UNLOADING THE CAMERA:**

When the red figure "20" or "36" (20 or 36 exposures) appears against the index mark in the frame counter window, the end of the film has been reached.

### **Steps for Unloading the Camera:**

1. Press in the rewind release button on the camera bottom ([Fig. 25](#)).
2. Lift up the rewind crank on the rewind knob ([fig. 26](#)).---
3. Turn the rewind crank in a clockwise direction ([Fig. 26](#)). Tension will be felt as the film is being rewound into the cartridge. Stop rewinding when the tension ceases. Open the camera back by pulling out the rewind knob all the way and lift out the film cartridge ([Fig. 27](#)). The rewind button on the camera bottom will snap back into position when the film advance lever is next operated. Have the film processed without delay.

### **CHANGING THE LENS:**

Your Chinon CE-3 Memotron is equipped with a screw mount which accepts any interchangeable lens with the Pentax / Practica screw mount. To remove the lens, turn the lens counterclockwise until it is separated from the camera body ([Fig. 28, 29](#)).

### **NOTE: DO NOT REMOVE OR REPLACE THE LENS WHILE THE CAMERA IS FUNCTIONING.**

In normal use the Chinon CE-3 Memotron will produce perfectly exposed photographs, due to the automatic exposure system incorporated in the camera. However, some lighting conditions will occur that could misguide the system. Subjects with a very high contrast or strongly back-lit are examples. Such misguidance occurs with electronic shutter cameras since the exposure system continuously follows the fluctuations of light intensity up until the very instant that the exposure is made. To overcome these conditions a memory lock has been incorporated.

### **Steps for using the Exposure Memory:**

1. Focus the subject. Make sure that the shutter speed dial is set at the "Auto," position.
2. Press the shutter release button half way and measure the light on the main part of the subject you want to shoot excluding all unnecessary light from the side or background-([Figs. 30, 31, 32](#)). Then press the

exposure memory button which will instantly memorize the light value on the subject, locking it in place ([Fig. 33](#), [Fig. 34](#)). When the memory button is locked the green lamp in the viewfinder frame will stay on. When the exposure memory button is returned to the original position or the exposure has been made, the green lamp will go off.

3. With the exposure memory button locked compose the subject in the viewfinder as you desire. ([Fig. 35](#)). Then press the shutter release button all the way to take the photograph.

### **EXPOSURE COMPENSATION:**

The Chinon CE-3 Memotron camera incorporates an exposure compensation dial which can be utilized for special purposes such as bracketing exposures, compensation for back-lit or spot-lit situations. By rotating the ASA / DIN dial as shown in the following chart you can change your exposure by plus or minus one full F-stop (in 1/3 F-stop increments) ([Fig. 38](#)).

1. 1/2 X index 1 EV (1 F-stop) under exposure.

2. 2/3 EV (2/3 F-stop) under exposure.

3. 1/3 EV (1/3 F-stop) under exposure ([Fig. 36](#)).

4. 1 X index Correct Exposure.

5. 1/3 EV (1/3 F-stop) over exposure.

6. 2/3 EV (2/3 F-stop) over exposure ([Fig. 37](#)).

7. 2 X index 1 EV (1 F-stop) over exposure.

**NOTE: AFTER THE EXPOSURE HAS BEEN MADE, THE ASA NUMBER MUST BE RETURNED TO THE 1 X INDEX MARK FOR NORMAL EXPOSURE (#4).**

### **MANUAL EXPOSURE:**

By moving the shutter speed dial off the "Auto" setting manual shutter speeds can be set. There are two methods of selecting the correct exposure.

1. Set the required shutter speed on the dial. While depressing the shutter release button half way observe the meter in the viewfinder. Rotate the lens aperture ring until the needle aligns with the corresponding shutter speed figure on the scale in the viewfinder ([Fig. 39](#)).

2. Set the required aperture on the lens. Slightly depress the release button and observe which shutter speed is indicated in the viewfinder. Set this speed on the shutter speed dial. If for special purposes it is necessary to either under or over expose the photograph, proceed by either of the previous methods. Then rotate the lens aperture ring to bring the meter needle above the shutter speed indicated in the viewfinder. This will produce over exposure. Conversely if the needle is brought below the indicated shutter speed then under exposure will result.

The Manual Shutter speeds can be used for:

1. A particular shutter speed that is required and beyond the coupling range of the meter e.g. 4 sec. exposure at 3200 ASA\_\_
2. Exposure compensation.
3. "B" ("Time" exposures longer than that possible in the auto mode).
4. Flash synchronization ("X").

**CAUTION: GET INTO THE HABIT OF IMMEDIATELY RETURNING THE SHUTTER SPEED DIAL TO THE "AUTO" POSITION AFTER USING THE MANUAL MODE TO AVOID POSSIBLE FUTURE INCORRECT EXPOSURES [\(Fig. 40\)](#).**

### **Manual Shutter Operation:**

Since the "X" (1/ 100 sec.) position employs a mechanical shutter, it is usable even when the batteries are dead. Setting the shutter speed dial to the "X" position whenever loading the camera with film or operating the shutter in an unload camera will also save unnecessary battery drain.

### **DEPTH OF FIELD**

Depth of field designates the nearest and furthest limits of the area that will be sharp in the picture in front of and beyond the subject. Depth of field is controlled by the f/stop. The larger the lens opening (f/stop), the shallower is the depth of field. The smaller the lens opening, the greater the depth of field will become [\(Fig. 41, 42\)](#).

### **Visible check in the viewfinder:**

Set the lens at selected lens opening on the F stop ring. Depress the shutter release button half way and observe the subject through viewfinder. This will enable you to preview the area of sharpness in the picture before shooting.

### **Depth of Field Scale:**

The depth of field scale indicates (after focusing) the approximate area that will be sharp in the picture. Locate on the depth of field scale the corresponding pair of f/stop figures. The distance between these two f/stop figures on the focusing ring will be the area of sharpness in your picture [\(Fig. 43\)](#).

### **THE SELF-TIMER:**

This device, when set, trips the shutter mechanism after a delay of 7-12 seconds. It is necessary if the photographer wishes to be in the picture, and is useful for tripping the shutter at a slow shutter speed if a cable release is not available.

When using the self-timer the camera must of course be mounted on a tripod, or a solid support of some kind. To operate, move the self-timer lever counterclockwise as far as it will go. Advance the film transport lever. Upon pressing the shutter release button the self timer mechanism will start to operate [\(Fig. 44, 45\)](#). If the self-timer is used in the "Auto" mode, turn the viewfinder blind lever clock wise, closing the viewfinder system and thereby preventing extraneous light from influencing the metering system [\(Fig. 46\)](#).

### **USING ELECTRONIC FLASH:**

It is advisable to use flash when the exposure meter indicates that the light level is too low, such as indoors, at night time, or in daylight where the subject is too dark to provide adequate exposure ([Figs. 47, 48](#)). Electronic flash units as well as conventional flash units using flashbulbs may be utilized. Your Chinon CE-3 Memotron has a hot shoe (accessory shoe with built-in flash contact) try either with a standard P.C. outlet for "X" synchronization ([Fig. 49](#)). Electronic flash units having a foot with built-in contact may be used without a connecting cord. As the hot shoe has "X" type synchronization, it can be used with electronic flash at "X" (1/ 100) ([Fig. 50](#)) or at slower shutter speeds, the lens aperture is determined by the calculation table indicated on flash units.

**NOTE: WHEN "FP" OR "M" FLASH BULBS ARE USED, THE P.C. CONNECTING CORD SHOULD BE INSERTED INTO THE "X" TERMINAL AND THE SHUTTER SPEED SET AT 1/ 15 OR A SLOWER SHUTTER SPEED. IT IS ADVISABLE TO USE A TRIPOD FOR SLOW SHUTTER SPEED PHOTOGRAPHY.**

#### **USING INFRA-RED FILM:**

To use Infra-red film an extra focusing adjustment must be made. After focusing note the figure that is adjacent to the red diamond on the distance scale then move that figure over to the red "R" marked to the right side of the red diamond ([Fig. 51](#)). This adjustment is only required for black and white infra-red film. When using color infra-red film, focus in the normal way.

#### **MACRO PHOTOGRAPHY**

The world of close-up photography has always been a complicated extension of normal photography. Now for the first time with your Chinon C-3 or CM-3, compact SLR, equipped with Chinon's unique 50mm f/1.7 macro lens, you can explore this fantastic world of photography without the costly addition of special equipment. Whether you are photographing an industrial application such as an ultra close-up of a printed circuit, or even an esoteric whim such as photographing a beautiful close-up of a dew drop on a flower petal, you can, without the addition of any accessories, open up new vistas in photographic applications. The only limit is your imagination.

The science of macro photography revolves around a close-up reproduction ratio which is not normally obtainable with standard focal length lenses. Since more and more photographers are exploring this highly creative world of macro-photography, Chinon has developed through extensive optical research, this unique ultra fast 50mm f/1.7 macro lens. It is available as a standard lens on both new SLR models.

#### **"Selection of the subject"**

Macro photography can cover the entire gamut but your subject should be relatively shallow in depth since depth of field becomes more critical in most macro situations. Particular emphasis should be placed on steadying the camera. Therefore, a tripod is almost an absolute necessity in all macro applications because the subject matter is being highly magnified. Under many macro situations, where lighting is not an important factor, it is highly recommended that you use a low speed film such as Panatomic3 X\*, Kodachrome 25\*, and Kodacolor II\*. In most instances your macro photograph will be more impressive when it is enlarged to a minimum of an 8" x 10" print. Accordingly you should keep the grain of the film "super fine" by using the recommended films. However, when lighting conditions necessitate a high speed film such as Tri-X\* or Kodacolor 400\* it should not be regarded as a critical deterrent. Your Chinon 50mm f/1.7 macro lens is of the highest resolving power and the results will be acceptable with any type of

film. Couple the fantastic features of the new CM-3 and C~3 with the Chinon Power Winder and the 50mm f/1.7 Chinon macro lens and creative capabilities are virtually endless. In addition to the 50mm f/1.7 macro lens your new CE-3 and CM-3 accepts an entire "system" of top quality lenses:...

#### **MACRO LENSES:**

50mm f/1.7MC Macro

55mm f/ 1.7 Macro

40 ~ 105mm f/3.5 MC Macro

85 ~ 210mm f/4.5 MC Macro

\* Panatomic X, Kodachrome 25, and Kodacolor II and Tri-X and Kodacolor 400 are registered trademarks of Eastman-Kodak.

#### **CHINON POWER WINDER:**

Your Chinon C~3 Memotron Compact single lens reflex camera can also be used with the new Chinon Power Winder when motorized photography is desired. This sophisticated accessory enhances the versatility of your new camera and opens up new horizons for creative photography ([Fig. 52](#)).

The Power Winder, designed with the latest electronic technology, employs a special computer "memory" chip which monitors key functions essential to motorized photography ([Fig. 53](#)).

#### **Single Frame Mode:**

As in normal photography however the Power Winder can be coupled with an accessory remote control device ([Fig. 54](#)).

#### **Continuous Mode:**

Outstanding "hi-speed" effects such as subjects moving or changing expressions can be caught on film. Couple this feature with the unique pre-set counter and electronic interval timer features and you can do almost anything photographically with your new Chinon camera ([Fig. 55](#)).

#### **Pre-Set Counter:**

The special "memory" chip monitors a preselected amount of exposures up to 24 frames - at a set of a dial ([Fig. 56](#)).

#### **Interval Timer:**

Time lapse photography at your fingertips. By means of the "unique" memory chip it is now possible to make exposures up to 30 seconds apart ([Fig. 57](#)).

It is possible to photograph just the same as in normal photography even when your Power Winder is attached to your new Chinon camera.---

1. Remove the film winder coupler cover located on the bottom of your Chinon CE-3 Memotron by turning it counterclockwise and it should be stored in the storage socket of the Power Winder ([Fig. 58](#)).

2. The C / S dial of the Power Winder should be turned to the off position so that frames are not accidentally exposed when the winder is installed to the camera body.

3. Insert the guide pin of the winder into the pin receptacle located on the bottom of the camera and rotate the winder attachment screw clockwise until the winder is securely fastened to the camera body ([Fig. 59](#)).

**NOTE: PLEASE MAKE SURE YOU READ THE INSTRUCTIONS PACKAGED WITH YOUR POWER WINDER FOR MORE OPERATING DETAILS AND OPERATING TECHNIQUES.**

#### CARE OF THE CAMERA:

Your Chinon C~3 Memotron single lens reflex camera is a precision instrument. Used with care, it will provide years of service. Protect your camera from dirt, rain, dampness, and excessive heat. Avoid touching the lens. To clean the lens wipe it gently with a soft lintless, cloth or tissue, Do not use eyeglass tissues as they might damage the lens coating.

#### CHINON INTERCHANGEABLE LENSES

##### STANDARD LENSES:

50mm f/2.8  
f/1.7 MC Macro  
55 mm f/ 1.7  
f/1.7 MC  
f/1.7 Macro  
f/1.4  
f/1.4 MC

##### WIDE ANGLE LENSES:

24mm f/2.5 MC  
28mm f/2.8  
f/2.8 MC  
35mm f/2.8  
f/2.8 MC

##### TELEPHOTO LENSES:

135mm f/2.8  
f/2.8 MC  
200mm t/3.5  
f/3.5 MC  
300mm f/5.6 MC  
500mm f/8.0 (mirror)

##### ZOOM LENSES:

40 ~ 105mm f/3.5 MC Macro  
75 ~ 205mm f/3.5  
85 ~ 210mm t/4.5 MC  
85 ~210mm f/4.5 MC Macro

90 ~ 190mm f/5.6

\*With a single control ring for zooming and focusing.

## CHINON ACCESSORIES

Power Winder  
Remote Control Unit  
Auto-Extension Rings  
Bellows  
Table Tripod  
Mini-Copy stand  
Spare Ring for Mini-Copy stand  
Cable Release (13 inch)  
Angle Finder  
Eyepiece Adapter (-3, +1, +3)  
Rubber Eyepiece  
Filter (52mm/55mm) IA, UV, Y2, ND4, PL  
Rubber Lens Hood (52mm/55mm)  
Neck Strap  
Wrist Strap  
Standard Lens Cap (52mm/55mm/62mm)  
Lens Cap with 2 clips (52mm/55mm)  
Lens Mount Cap  
Body Cap

Because we continually strive to improve our products, we may change without prior notice.



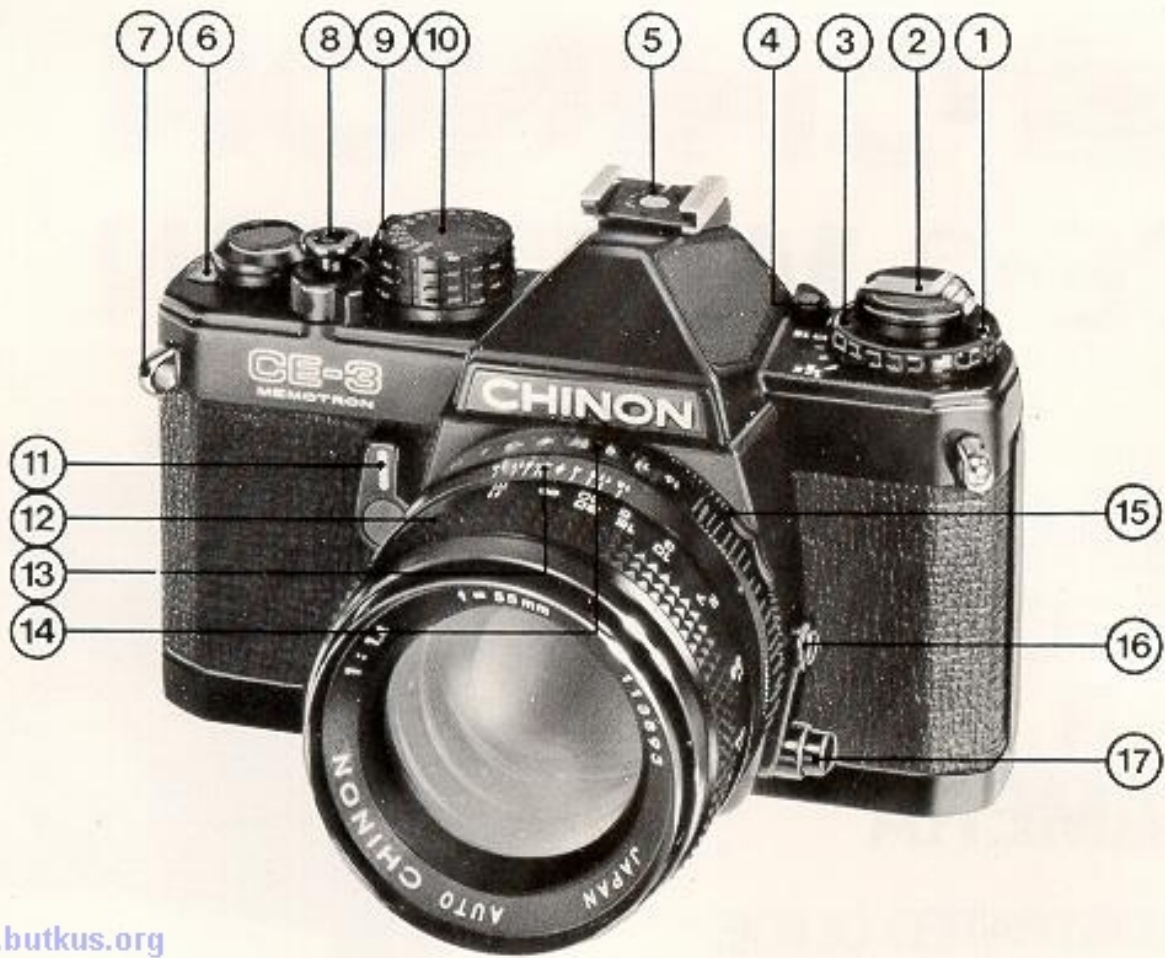

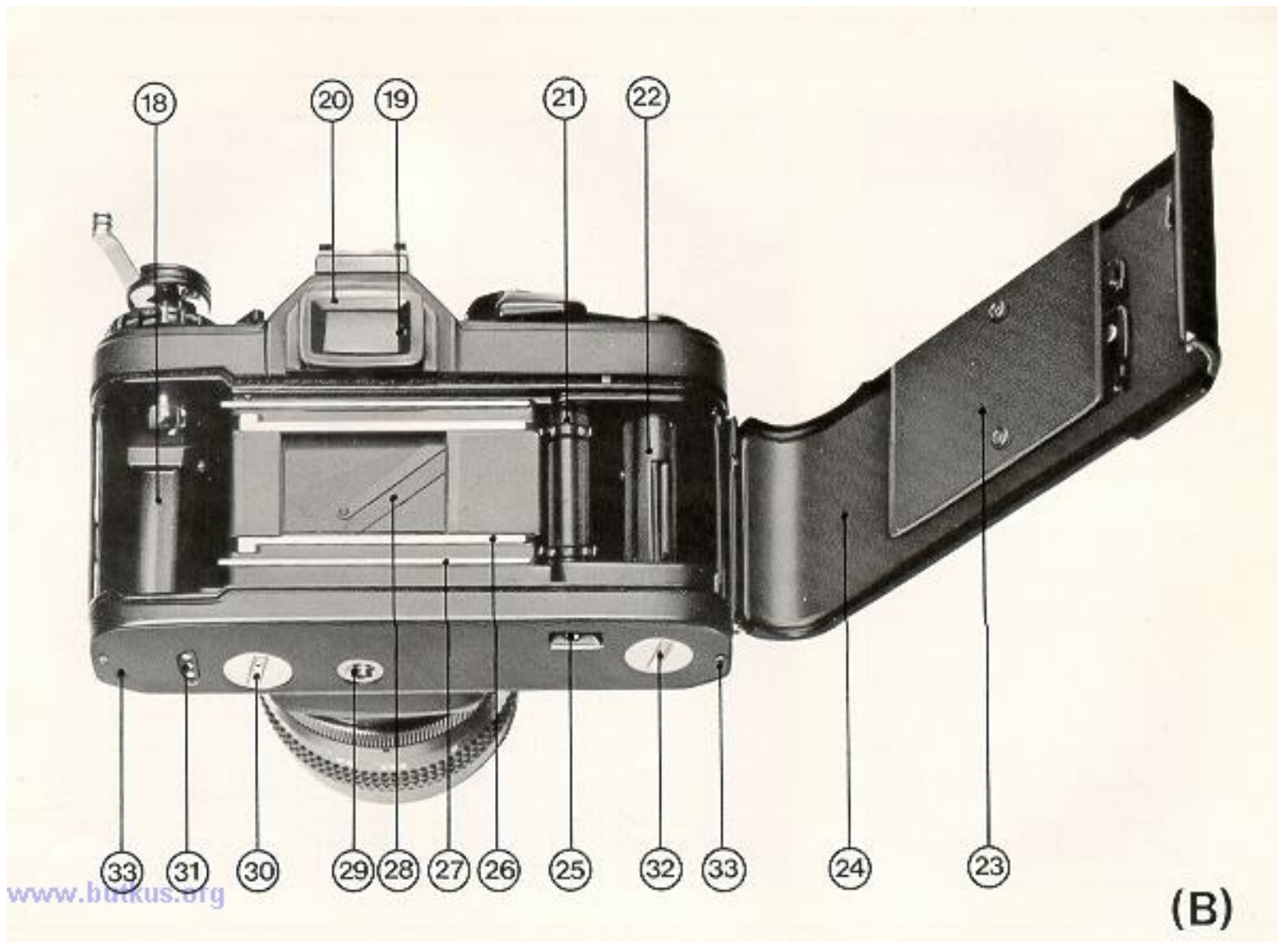

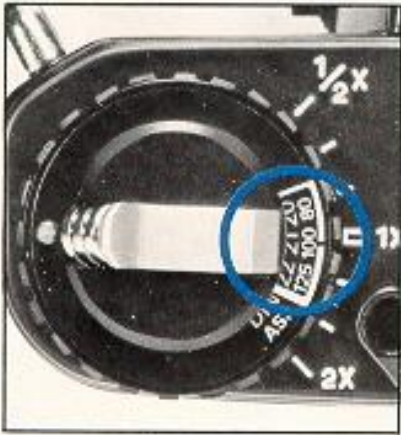

F

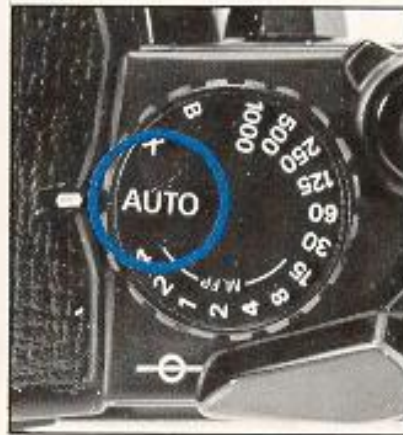

G



H



I



J



1



2



3

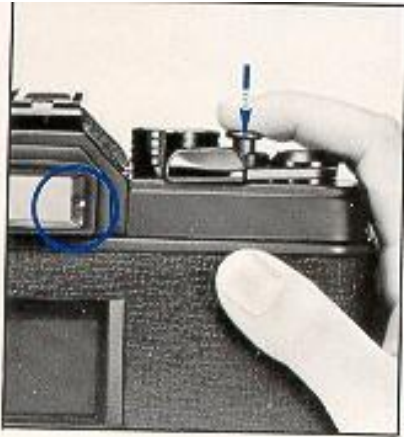

4



5



6

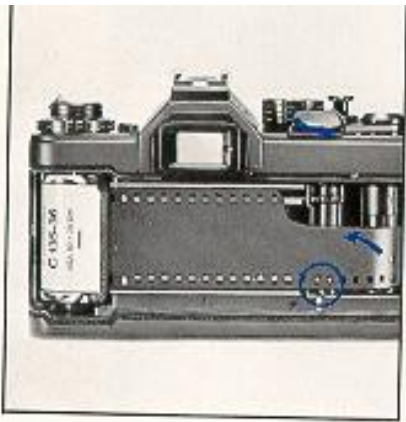

7

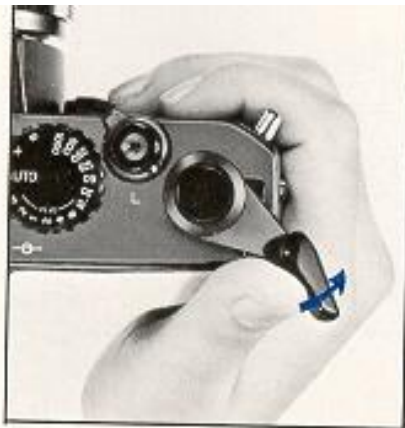

8



9

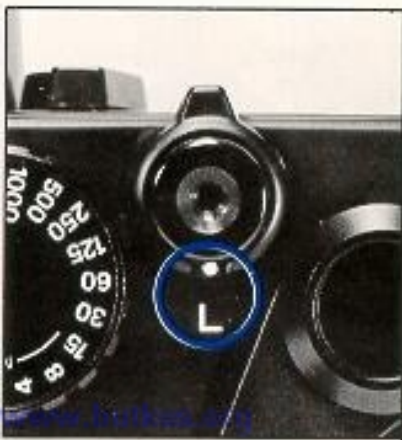

10



11



12



13



14



15

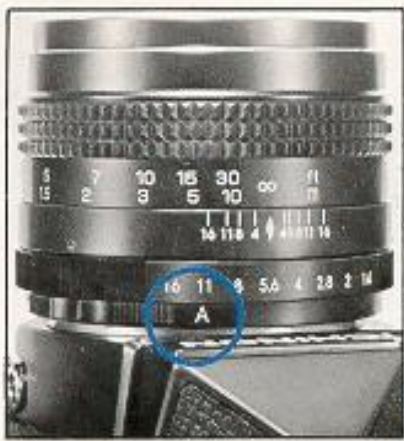

16



17



18



19



20



21

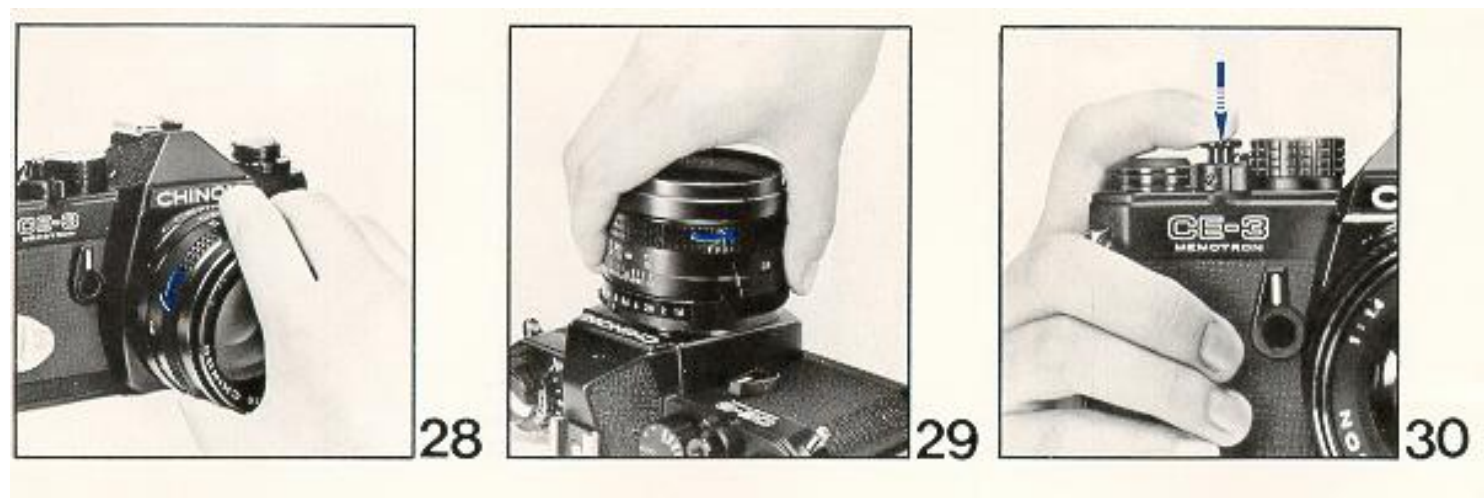
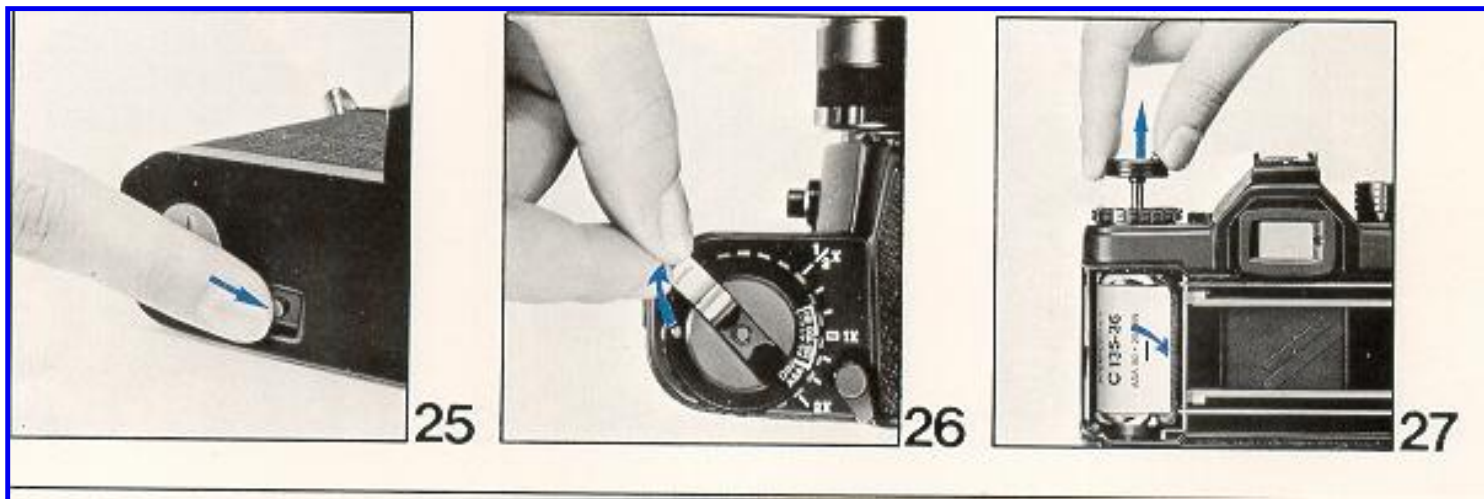
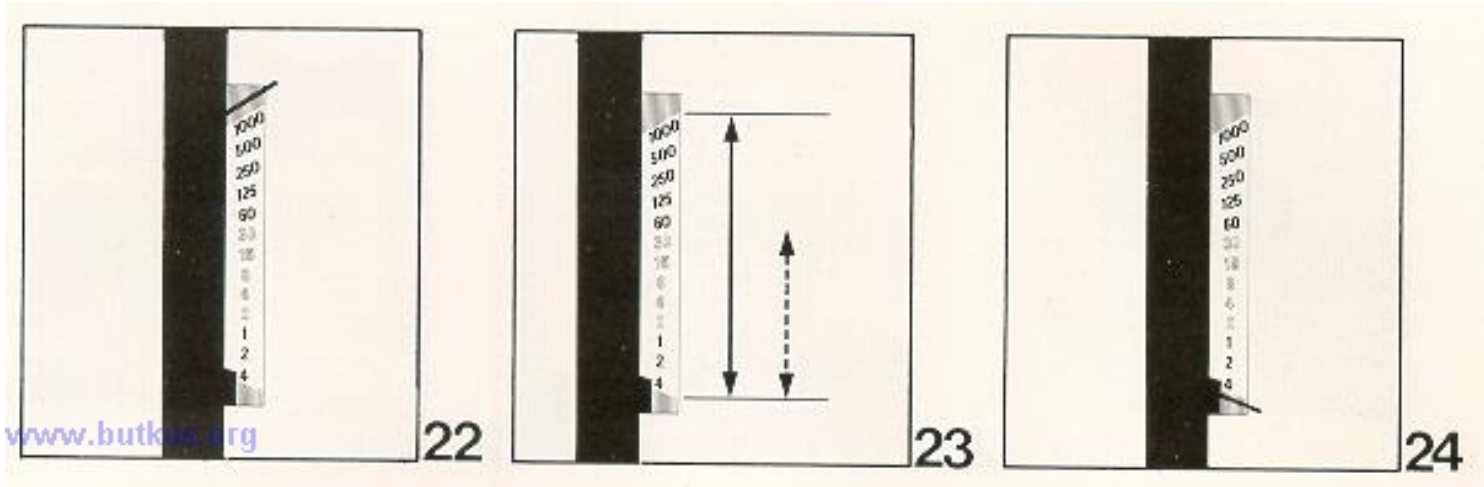



31



32



33

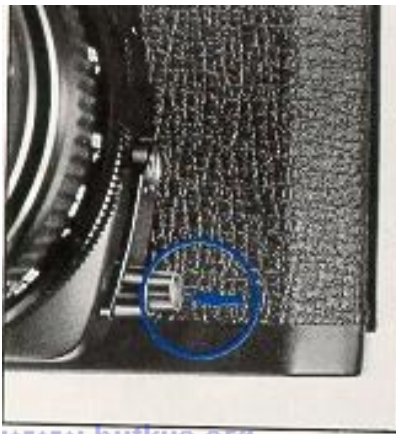

34



35

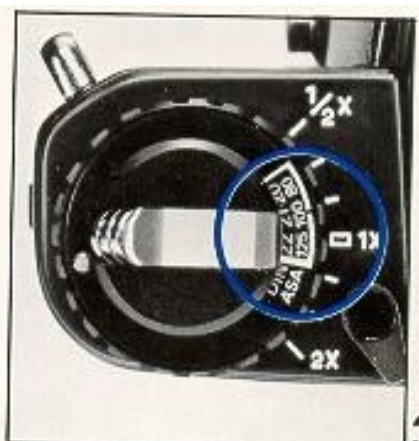

36

[www.butkus.org](http://www.butkus.org)



37



38

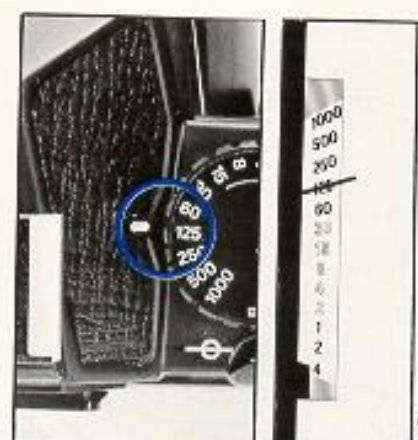

39



40



41



42



43



44



45



46



47



48





49





58



59