

Crestron **DM-TX-200**

DigitalMedia™ CAT Transmitter 200

Operations & Installation Guide



This document was prepared and written by the Technical Documentation department at:



Crestron Electronics, Inc.
15 Volvo Drive
Rockleigh, NJ 07647
1-888-CRESTRON

Regulatory Compliance

As of the date of manufacture, the DM-TX-200 has been tested and found to comply with specifications for CE marking and standards per EMC and Radiocommunications Compliance Labelling.



Federal Communications Commission (FCC) Compliance Statement

This device complies with part 15 of the FCC Rules. Operation is subject to the following conditions:
(1) This device may not cause harmful interference and (2) this device must accept any interference received, including interference that may cause undesired operation.

CAUTION: Changes or modifications not expressly approved by the manufacturer responsible for compliance could void the user's authority to operate the equipment.

NOTE: This equipment has been tested and found to comply with the limits for a Class B digital device, pursuant to part 15 of the FCC Rules. These limits are designed to provide reasonable protection against harmful interference in a residential installation. This equipment generates, uses and can radiate radio frequency energy and, if not installed and used in accordance with the instructions, may cause harmful interference to radio communications. However, there is no guarantee that interference will not occur in a particular installation. If this equipment does cause harmful interference to radio or television reception, which can be determined by turning the equipment off and on, the user is encouraged to try to correct the interference by one or more of the following measures:

- Reorient or relocate the receiving antenna
- Increase the separation between the equipment and receiver
- Connect the equipment into an outlet on a circuit different from that to which the receiver is connected
- Consult the dealer or an experienced radio/TV technician for help

Industry Canada (IC) Compliance Statement

This Class B digital apparatus complies with Canadian ICES-003.

Cet appareil numérique de la classe B est conforme à la norme NMB-003 du Canada.

This device includes an aggregation of separate independent works that are each generally copyrighted by Crestron Electronics, Inc., with all rights reserved. One of those independent works, Linux Bridge Project, is copyrighted under the GNU GENERAL PUBLIC LICENSE, Version2, reproduced in "GNU General Public License" on page 25, where the corresponding source code is available at: <ftp://ftp.crestron.com/gpl>.

Contents

DigitalMedia™ CAT Transmitter 200: DM-TX-200	1
Introduction	1
Features and Functions	1
Applications	4
Specifications	5
Physical Description	9
Setup	13
Network Wiring	13
Identity Code	13
Installation	14
Hardware Hookup	15
Programming Software	16
Earliest Version Software Requirements for the PC	16
Programming with SIMPL Windows	16
Example Program	18
Uploading and Upgrading	19
Establishing Communication	19
Firmware	20
IP Configuration	21
DM Tool	21
Problem Solving	22
Troubleshooting	22
Check Network Wiring	22
Reference Documents	23
Further Inquiries	23
Future Updates	23
Return and Warranty Policies	24
Merchandise Returns / Repair Service	24
CRESTRON Limited Warranty	24
GNU General Public License	25

DigitalMedia™ CAT Transmitter 200: DM-TX-200

Introduction

The DM-TX-200 is a DigitalMedia™ (DM) CAT transmitter and switcher that provides a convenient interface for computers and other high-resolution AV sources as part of a complete DigitalMedia system. With both HDMI™ and RGB inputs, the DM-TX-200 is ideal for use at a lectern, conference table, wall plate or any remote location in a boardroom, classroom or residence to provide an input for a laptop computer or similar source. It connects to any DM switcher or DM-RMC-100 Room Controller (both sold separately) via a single DM cable.

Features and Functions

- DigitalMedia™ transmitter and multimedia interface
- Built-in 2x1 AV switcher
- DM CAT output supports up to 450 foot (137 meter) cable length¹
- Compact surface mount design
- Fits in a Wiremold® 6000 Series Raceway
- Provides HDMI and RGB/component video inputs
- Supports DVI and DisplayPort Multimode sources²
- Includes mini-TRS stereo audio input
- Provides onboard auto-switching capability
- Includes USB HID keyboard/mouse port
- Affords single wire connection to a DM-RMC-100 or DM switcher (both sold separately)
- Detects and reports detailed video and audio input information
- Performs automatic AV signal format management via EDID
- Enables device control via CEC
- Easy setup and diagnostics tools via software
- Extends the life of analog based AV systems

1. For DigitalMedia CAT wiring, use DM-CBL DigitalMedia Cable. Up to two DM Repeaters (model DM-DR, sold separately), may be required. Refer to the latest version of the Crestron DigitalMedia Design Guide (Doc. 4789) for complete wiring guidelines. It can be obtained from the Crestron website (www.crestron.com/manuals).
2. HDMI requires an appropriate adapter or interface cable to accommodate a DVI or DisplayPort Multimode signal. CBL-HD-DVI and CBL-DP-HD interface cables sold separately.

DigitalMedia™

As the leader in HDMI and control system technologies, Crestron® has developed DigitalMedia, the first complete HD AV distribution system that takes HDMI to a higher level and allows virtually any mix of AV sources to be distributed throughout the home, office, school or virtually any other facility.

DigitalMedia distributes uncompressed digital video and audio signals up to 450 feet (137 meters) using DM cable¹. DigitalMedia thoughtfully manages all of the different signals and devices, matching each source's output to the capabilities of the selected display(s) without using scaling or compression. Every signal is preserved in its native video resolution and audio format, ensuring a pure, lossless signal path throughout.

Multimedia Computer /AV Interface

The DM-TX-200 provides simple switching between its two inputs. Its HDMI input supports HDMI and HDCP, handling WUXGA computer resolutions and 1080p60 HDTV with multi-channel lossless audio. The HDMI input can also handle DVI and DisplayPort Multimode signals using an appropriate adapter or dongle². The RGB input handles all analog RGB signals up to WUXGA 1920 x 1200 pixels, as well as component video up to 1080p60³. A mini TRS stereo audio input is also provided to accept analog audio signals from an unbalanced line level or headphone output.

NOTE: HDMI requires an appropriate adapter to accommodate a DVI or DisplayPort Multimode signal. RGB connection requires an appropriate adapter to accommodate a YP_bP_r component video signal. Adapters not included.

Used with a single DM-RMC-100 Room Controller and optional Crestron Control System (both sold separately), the DM-TX-200 affords a very simple solution for extending a multimedia computer or AV signal to a single display up to 450 feet (137 meters) away¹. As part of a larger system using a DM-MD series switcher (sold separately), multiple DM-TX-200s may be installed to enable distribution of several sources at different locations to feed multiple displays throughout any room or larger facility.

Keyboard/Mouse Extender

When connected to a DM-MD series switcher (sold separately), the DM-TX-200 functions as a keyboard/mouse extender, allowing a USB HID (Human Interface Device) compliant keyboard and/or mouse at the podium or conference table to control a computer or other host device located at the central equipment rack.

HID devices include mice, keyboards, trackballs and composite devices (e.g. combination keyboard/trackball devices). These devices do not require driver installation on most common operating systems (Windows XP/Vista and Mac OS).

1. For DigitalMedia CAT wiring, use DM-CBL DigitalMedia Cable. Up to two DM Repeaters (model DM-DR, sold separately), may be required. Refer to the latest version of the Crestron DigitalMedia Design Guide (Doc. 4789) for complete wiring guidelines.
2. HDMI requires an appropriate adapter or interface cable to accommodate a DVI or DisplayPort Multimode signal. CBL-HD-DVI and CBL-DP-HD interface cables sold separately.
3. The RGB input can accept component, composite and S-video signals via direct interface to Crestron MPS Series products (sold separately) or through an appropriate adapter (not included). Input sync detection is not provided for composite or S-video signal types through the RGB connection.

There are four options for connecting USB devices to the **USB** port on the DM-TX-200:

1. One mouse
2. One keyboard
3. One mouse and one keyboard connected through a USB hub
4. One composite USB device

EDID Format Management

The DM-TX-200 allows for management of the EDID (Extended Display Identification Data) information that passes between the display devices and input sources in the system. Using Crestron Toolbox™ software, the format and resolution capabilities of each device can be assessed and managed through the DM-TX-200, ensuring reliable operation by instructing sources to output only the resolutions and formats that can be handled by the displays and system wiring.

CEC Embedded Device Control

The primary objective of every Crestron system is to enable precisely the control desired for a seamless user experience. DigitalMedia provides an alternative to conventional IR and RS-232 device control by harnessing the CEC (Consumer Electronics Control) signal embedded in HDMI. Through its connection to the control system, the DM-TX-200 provides a gateway for controlling the connected source device right through the HDMI connection, potentially eliminating the need for any dedicated control wires or IR probes. Through proper CEC signal management, DigitalMedia allows you to take control of each device in the system as you like.

Compact and Versatile

The DM-TX-200 is designed to be placed on a shelf or mounted on a flat surface. It is compact enough to fit discreetly inside a presentation lectern or beneath a table and can even be concealed inside a divided Wiremold® 6000 Series Raceway. An array of indicators on the front of the DM-TX-200 provides for easy setup and troubleshooting, verifying the status of connections and signal activity at a glance. Advanced configuration is enabled through Crestron Toolbox software.

A Digital Upgrade for Legacy Systems

The DM-TX-200 also affords a perfect signal converter for integrating DigitalMedia with analog-based systems like Crestron MPS, QuickMedia® and the CEN-RGBHV series (all sold separately). A simple HD15 VGA cable connected between the output of an MPS system and the input of the DM-TX-200 allows every RGB, component, S-video and composite video input on the MPS to be converted to DigitalMedia*. Analog audio is converted similarly through a simple unbalanced stereo audio cable. The DM-TX-200's HDMI input may also be used to expand the input capabilities of the MPS system to handle digital AV sources.

* The RGB input can accept component, composite and S-video signals via direct interface to Crestron MPS Series products (sold separately) or through an appropriate adapter (not included). Input sync detection is not provided for composite or S-video signal types through the RGB connection.

Applications

The following diagram shows a DM-TX-200 in a basic application.

DM-TX-200 in a Basic Application

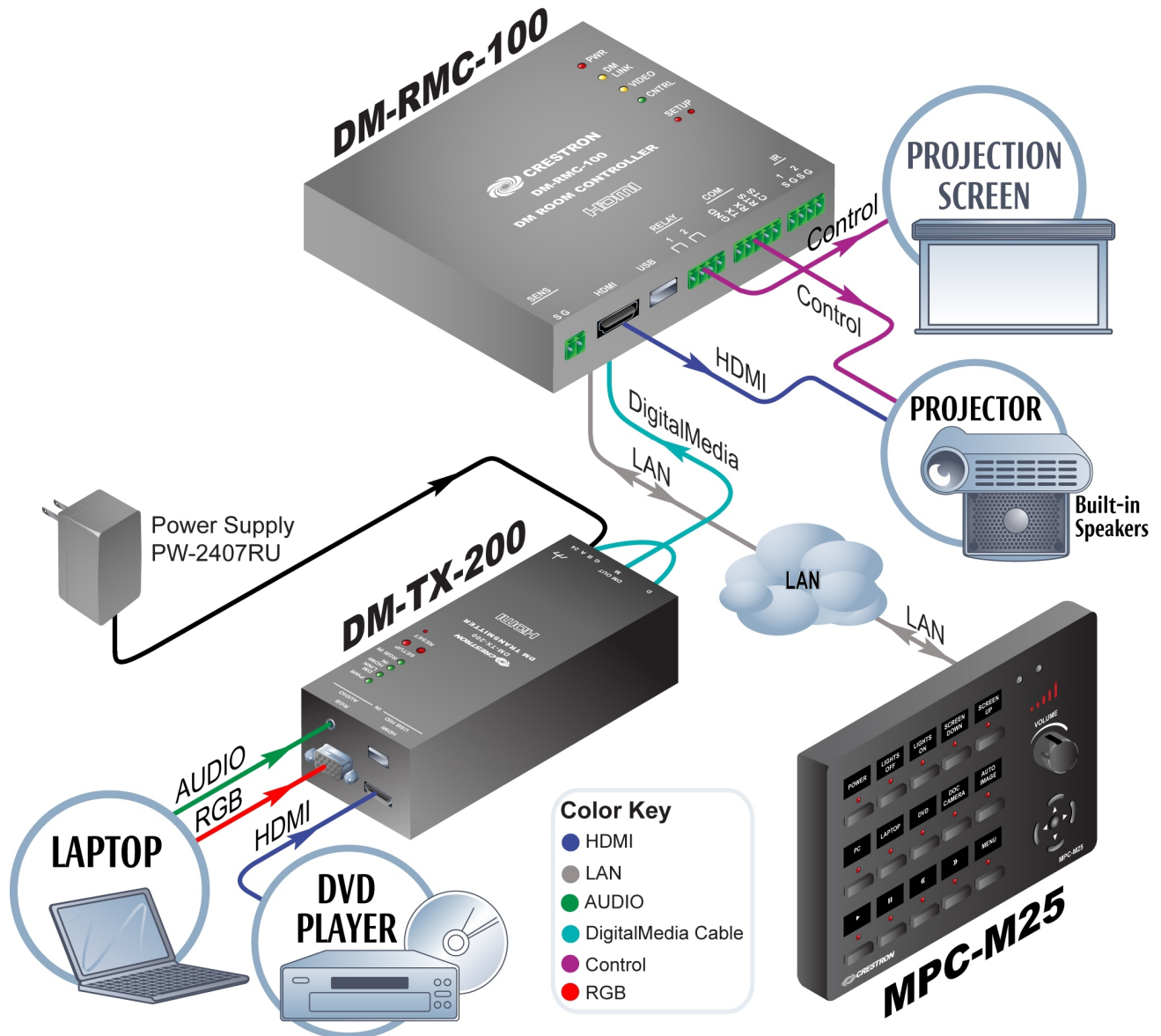

No LAN connection is required for the DM-TX-200 to transmit HDMI or USB in a point-to-point configuration. If you wish to use the control ports (IS, RS-232, Relay, Sense) from a control system, you can connect either LAN port (on the DM-RMC-100 or on the DM-TX-200) to the control system's network. Both devices will be connected because Ethernet is embedded inside DM. You may also use the other LAN connection to provide Ethernet connectivity to a remote device.

You only have to apply power to one (either the DM-RMC-100 or the DM-TX-200) and the other will receive it through the DMNet cable.

Specifications

Specifications for the DM-TX-200 are listed in the following table.

DM-TX-200 Specifications

SPECIFICATION	DETAILS
Video	
Switcher	2x1 combination digital/analog switch, Crestron QuickSwitch HD
Input Signal Types	HDMI, DVI ¹ , DisplayPort Multimode ¹ , RGB, component (YPbPr) ² , S-video (Y/C) ² , composite ²
Output Signal Type	DM CAT (DigitalMedia over twisted pair copper wire)
Formats	HDMI, DVI v. 1.0, HDCP v.1.2 content protection support, RGBHV up to UXGA/WUXGA, HDTV up to 1080p60, NTSC or PAL
Input Resolutions	
HDMI & DVI Progressive	640 x 480 @ 60 Hz, 720 x 480 @ 60 Hz (480p), 720 x 576 @ 50 Hz (576p), 800 x 600 @ 60 Hz, 848 x 480 @ 60 Hz, 852 x 480 @ 60 Hz, 854 x 480 @ 60 Hz, 1024 x 768 @ 60 Hz, 1024 x 852 @ 60 Hz, 1024 x 1024 @ 60 Hz, 1280 x 720 @ 50 Hz (720p50), 1280 x 720 @ 60 Hz (720p60), 1280 x 768 @ 60 Hz, 1280 x 800 @ 60 Hz, 1280 x 960 @ 60 Hz, 1280 x 1024 @ 60 Hz, 1360 x 768 @ 60 Hz, 1365 x 1024 @ 60 Hz, 1366 x 768 @ 60 Hz, 1400 x 1050 @ 60 Hz, 1440 x 900 @ 60 Hz, 1600 x 900 @ 60 Hz, 1600 x 1200 @ 60 Hz, 1680 x 1050 @ 60 Hz, 1920 x 1080 @ 24 Hz (1080p24), 1920 x 1080 @ 25 Hz (1080p25), 1920 x 1080 @ 50 Hz (1080p50), 1920 x 1080 @ 60 Hz (1080p60), 1920 x 1200 @ 60 Hz, 2048 x 1080 @ 24 Hz, 2048 x 1152 @ 60 Hz, plus any other resolution allowed by HDMI up to 165 MHz pixel clock

(Continued on following page)

DM-TX-200 Specifications (Continued)

SPECIFICATION	DETAILS
Video	
Input Resolutions (Continued)	
HDMI & DVI Interlaced	720 x 480 @ 30 Hz (480i), 720 x 576 @ 25 Hz (576i), 1920 x 1080 @ 25 Hz (1080i25), 1920 x 1080 @ 30 Hz (1080i30), plus any other resolution allowed by HDMI up to 165 MHz pixel clock
RGB	640 x 480 @ 60 Hz, 720 x 480 @ 60 Hz (480p), 720 x 576 @ 50 Hz (576p), 800 x 600 @ 60 Hz, 848 x 480 @ 60 Hz, 1024 x 768 @ 60 Hz, 1280 x 720 @ 50 Hz (720p50), 1280 x 720 @ 60 Hz (720p60), 1280 x 768 @ 60 Hz, 1280 x 800 @ 60 Hz, 1280 x 960 @ 60 Hz, 1280 x 1024 @ 60 Hz, 1360 x 768 @ 60 Hz, 1366 x 768 @ 60 Hz, 1400 x 1050 @ 60 Hz, 1440 x 900 @ 60 Hz, 1600 x 1200 @ 60 Hz, 1680 x 1050 @ 60 Hz, 1920 x 1080 @ 24 Hz (1080p24), 1920 x 1080 @ 50 Hz (1080p50), 1920 x 1080 @ 60 Hz (1080p60), 1920 x 1200 @ 60 Hz, 2048 x 1080 @ 24 Hz, 2048 x 1152 @ 60 Hz
Component ²	480i, 576i, 480p, 576p, 720p50, 720p60, 1080i25 (1125 lines), 1080i30, 1080p30, 1080p50 (1125 lines), 1080p60
Composite and S-video ²	480i, 576
Output Resolutions	Matched to inputs
Analog to Digital Conversion	10-bit 165 MHz per each of three channels
Audio	
Switcher	2x1 combination digital/analog switch
Input Signal Types	HDMI, DisplayPort Multimode ¹ , analog stereo
Output Signal Type	DM CAT (DigitalMedia over twisted pair copper wire)
Formats, HDMI	Dolby Digital®, Dolby Digital EX, DTS®, DTS-ES, DTS 96/24 5.1, up to 8ch PCM
Formats, Analog	Stereo 2-channel
Analog to Digital Conversion	24-bit 48 kHz

(Continued on following page)

DM-TX-200 Specifications (Continued)

SPECIFICATION	DETAILS
Audio (Continued)	
Performance (Analog)	
Frequency Response	20 Hz to 20 kHz ±0.75 dB
S/N Ratio	>90 dB, 20 Hz to 20 kHz A-weighted
THD+N	<0.05% @ 1 kHz
Stereo Separation	>90 dB
Communications	
DigitalMedia	DM CAT, DMNet, HDCP management, EDID format management, CEC
USB	Supports USB HID class devices
Power Requirements	
DMNet Power Usage	12 Watts (0.5 Amps @ 24 Volts DC)
Minimum 2-Series Control System Update File ^{3,4}	Version 4.001.1012 or later
Environmental	
Temperature	32° to 104° F (0° to 40° C)
Humidity	10% to 90% RH (non-condensing)
Heat Dissipation	41 BTU/Hr
Enclosure	
Chassis	Metal with black finish
Mounting	Freestanding, surface mountable (mounting bracket included); also fits in a divided Wiremold® 6000 Series Raceway
Dimensions	
Height	6.97 in (177 mm)
Width	2.76 in (70 mm) 3.95 in (100 mm) with mounting bracket
Depth	1.68 in (43 mm)
Weight	18 oz (493 g)
Available Accessories	
CBL-AUDIO	Crestron Certified Mini-TRS Stereo Audio Interface Cable
CBL-DP-HD	Crestron Certified DisplayPort to HDMI Interface Cable
CBL-HD	Crestron Certified HDMI Interface Cable
CBL-HD-DVI	Crestron Certified HDMI to DVI Interface Cable
CBL-VGA	Crestron Certified Computer-VGA Interface Cable
CBL-VGA-AUD	Crestron Certified Computer-VGA Interface Cable with Mini-TRS Audio
DM-CBL	DigitalMedia Cable
DM-CONN	DigitalMedia Cable Connector
DM-DR	DigitalMedia CAT Repeater

(Continued on following page)

DM-TX-200 Specifications (Continued)

SPECIFICATION	DETAILS
Available Accessories (Continued) MP-WP130 MP-WP131 MP-WP140 MP-WP150 MP-WP152 MP-WP160 MP-WP162 MP-WP185	Media Presentation Wall Plate – DB15HD Computer VGA with Mini-TRS Stereo Audio, Bulkhead Media Presentation Wall Plate – DB15HD Computer VGA with Mini-TRS Stereo Audio, Breakout Media Presentation Wall Plate – DVI-I with Mini-TRS Stereo Audio Media Presentation Wall Plate – HDMI with Mini-TRS Stereo Audio Media Presentation Wall Plate - HDMI Media Presentation Wall Plate – DisplayPort with Mini-TRS Stereo Audio Media Presentation Wall Plate - DisplayPort Media Presentation Wall Plate – Crestron DigitalMedia CAT with DMNet

1. HDMI requires an appropriate adapter or interface cable to accommodate a DVI or DisplayPort Multimode signal. CBL-HD-DVI and CBL-DP-HD interface cables sold separately.
2. The RGB input can accept component, composite and S-video signals via direct interface to Crestron MPS Series products (sold separately) or through an appropriate adapter (not included). Input sync detection is not provided for composite or S-video signal types through the RGB connection.
3. The latest software versions can be obtained from the Crestron website. Refer to the NOTE following these footnotes.
4. Crestron 2-Series control systems include the AV2 and PRO2. Consult the latest Crestron Product Catalog for a complete list of 2-Series control systems.

NOTE: Crestron software and any files on the website are for authorized Crestron dealers and Crestron Authorized Independent Programmers (CAIP) only. New users may be required to register to obtain access to certain areas of the site (including the FTP site).

Physical Description

This section provides information on the connections, controls and indicators available on your DM-TX-200.

DM-TX-200 Physical View (Bottom Ports Shown)



DM-TX-200 Physical View (Top Ports Shown)



DM-TX-200 Overall Dimensions (Top View)

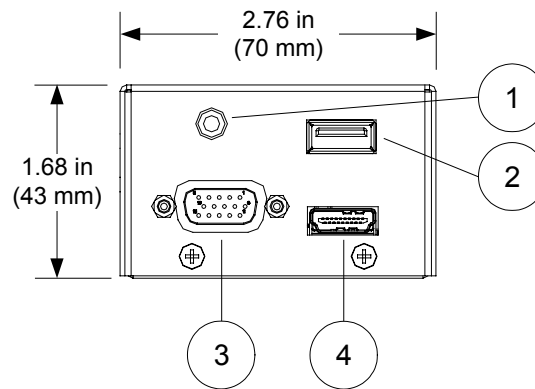



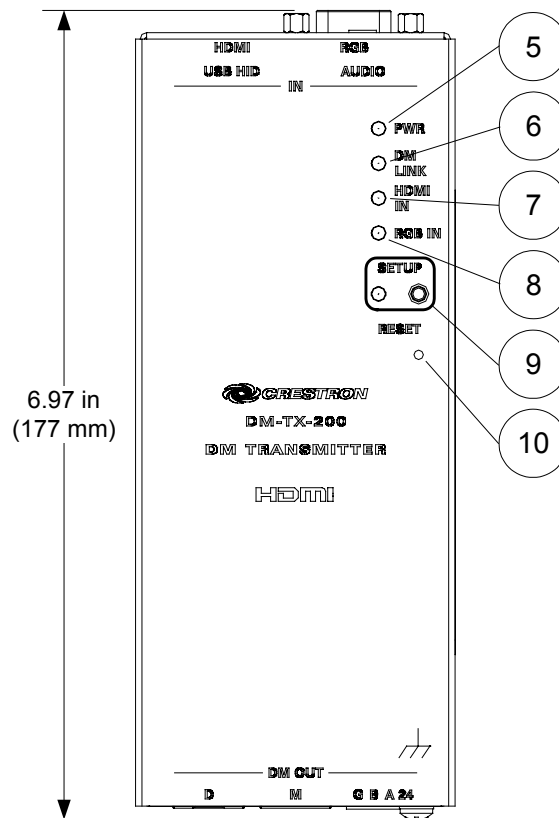

DM-TX-200 Overall Dimensions (Front View)

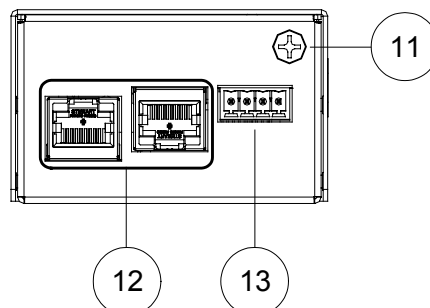

DM-TX-200 Overall Dimensions (Bottom View)

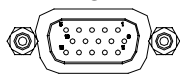
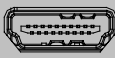

Connectors, Controls & Indicators

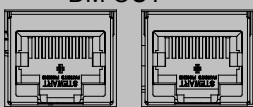
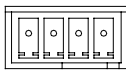
#	CONNECTORS ¹ , CONTROLS & INDICATORS	DESCRIPTION
1	AUDIO 	(1) 3.5 mm TRS mini phone jack; Unbalanced stereo line level audio input; Input impedance: 10 kΩ; Input level: 2 V _{rms} maximum
2	USB HID 	(1) USB Type A female; USB 1.1 host port for connection of a mouse, keyboard or other USB HID-compliant device
3	RGB 	(1) DB15HD female, RGB (VGA) or component YP _b P _r) video input ^{2, 3} Formats: RGBHV, RGBS, RG _s B, YP _b P _r ; Input level: 0.5 to 1.5 V _{p-p} with built-in DC restoration; Input impedance: 75 Ω; Sync input type: Autodetect RGBHV, RGBS, RG _s B, YP _b P _r ; Sync input level: 3 to 5 V _{p-p} ; Sync input impedance: 1 kΩ;
4	HDMI 	(1) 19-pin Type A HDMI female; HDMI digital video/audio input; Supports DVI and DisplayPort Multimode ⁴
5	PWR LED	(1) Green LED, indicates operating power supplied via DMNet
6	DM LINK LED	(1) Green LED, indicates connection to a downstream DM device
7	HDMI IN LED	(1) Green LED, indicates HDMI input is selected
8	RGB IN LED	(1) Green LED, indicates RGB input is selected
9	SETUP (LED and BUTTON)	(1) Red LED and (1) miniature pushbutton for Ethernet auto-discovery and default IP address
10	RESET BUTTON	(1) Miniature recessed pushbutton for hardware reset
11	Ground 	(1) 6-32 screw, chassis ground lug
12	DM OUT ^{5, 6} 	(1) DM CAT output composed of (2) 8-pin RJ-45 female, shielded; Connects to DM CAT input of a DM switcher, receiver/room controller or other DM device via DM-CBL ⁷ .
13	G B A 24 ^{8, 9} 	(1) 4-pin 3.5 mm detachable terminal block, DMNet port; Connects to DMNet port of a DM switcher, receiver/room controller or other DM device via DM-CBL ⁷ .

1. An interface connector for the **G B A 24** port is provided with the unit.

2. The RGB input can accept component, composite and S-video signals via direct interface to Crestron MPS Series products (sold separately) or through an appropriate adapter (not included). Input sync detection is not provided for composite or S-video signal types through the RGB connection.

3. Refer to the following table for the **RGB** connector pinouts.

RGB Port

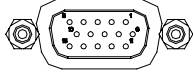
				
PIN #	RGB	YP _b P _r	S-VIDEO	COMPOSITE
1	R	P _r	C	
2	G	Y	Y	
3	B	P _b		Comp
13	H			
14	V			

4. HDMI requires an appropriate adapter or interface cable to accommodate a DVI or DisplayPort Multimode signal. CBL-HD-DVI and CBL-DP-HD interface cables sold separately.
5. To determine which is pin 1 on the cable, hold the cable so the end of the eight pin modular jack is facing away from you, with the clip down and copper side up. Pin 1 is on the far left.
6. The **DM OUT** port consists of two separate RJ-45 connectors labeled **D** and **M**. The **D** port carries HDMI signal. The **M** port carries data. Refer to the following table for the connector pinouts.

D and M Port

	
PIN #	WIRE COLOR
1	Orange/White
2	Orange
3	Green/White
4	Blue
5	Blue/White
6	Green
7	Brown/White
8	Brown

7. For DigitalMedia CAT wiring, use DM-CBL DigitalMedia Cable. Up to two DM Repeaters (model DM-DR, sold separately), may be required. Refer to the latest version of the Crestron DigitalMedia Design Guide (Doc. 4789) for complete wiring guidelines.
8. DMNet wiring is not compatible with Cresnet wiring. DMNet wiring cannot be daisy chained.
9. Refer to the following table for the **G B A 24** connector pinouts.

G B A 24 Port

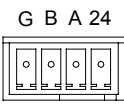
			
PIN #	SIGNAL	Description	Wire Color
G	Ground	DC Ground	Black
B	DMNet-	DMNet	Grey
A	DMNet+	DMNet	Orange
24	24V DC	DC Power	Red

Setup

Network Wiring

When wiring the DM network, consider the following:

NOTE: DMNet wiring and Cresnet® wiring are not compatible.

- Use Crestron Certified Wire.
- Use Crestron power supplies for Crestron equipment.
- Provide sufficient power to the system.
- For DigitalMedia CAT wiring, use DM-CBL DigitalMedia Cable. Up to two DM Repeaters (model DM-DR, sold separately) may be required. Refer to the latest revision of the Crestron DigitalMedia Design Guide (Doc. 4789) for complete wiring guidelines.

CAUTION: Insufficient power can lead to unpredictable results or damage to the equipment. Please use the Crestron Power Calculator to help calculate how much power is needed for the system (www.crestron.com/calculators).

For more details, refer to “Check Network Wiring” which starts on page 22.

Identity Code

NOTE: In the SIMPL™ Windows program, when the DM-TX-200 is dropped onto an input card of a DM switcher, its IP ID is assigned automatically and does not require additional programming or configuration. Use the information below when the DM-TX-200 is dropped directly into an Ethernet slot on the control system in SIMPL Windows, without a DM switcher.

The IP ID is set within the DM-TX-200's table using Crestron Toolbox. For information on setting an IP table, refer to the Crestron Toolbox help file. The IP IDs of multiple DM-TX-200 devices in the same system must be unique.

When setting the IP ID, consider the following:

- The IP ID of each unit must match an IP ID specified in the SIMPL Windows program.
- Each device using IP to communicate with a control system must have a unique IP ID.

Installation

To prevent overheating, do not operate this product in an area that exceeds the environmental range listed in the table of specifications.

The following tools and accessories are required for mounting a DM-TX-200 to a surface:

- Phillips screwdriver (not supplied)
- Metal mounting plate (included)
- Two #04-40 x 3/16" pan head Phillips screws (included)

Use the following procedure to mount the DM-TX-200 to a surface:

1. Attach the included metal mounting plate (2023867) to the rear of the unit using the two included #04-40 x 3/16" Phillips screws (2007145), as shown in the following illustration.

Attaching the Mounting Plate to the DM-TX-200

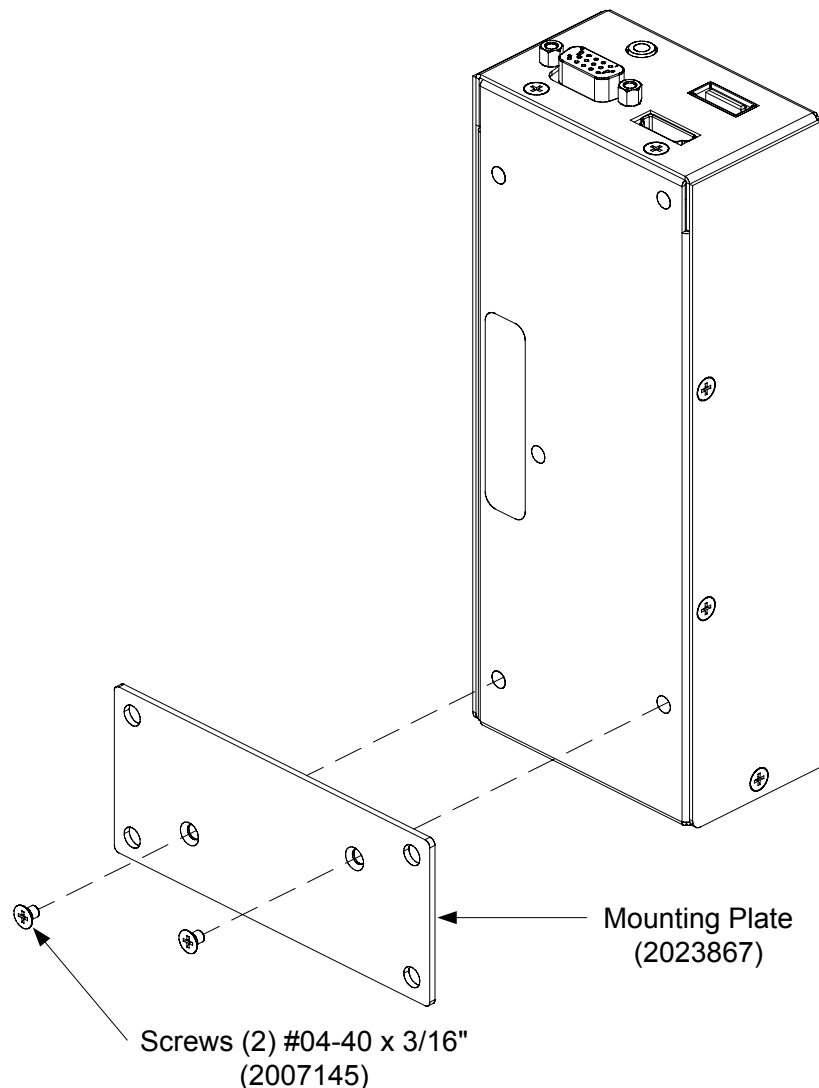

2. Attach the DM-TX-200 to the selected surface using four screws (not supplied) through the holes in the mounting plate.

Hardware Hookup

Make the necessary connections as called out in the illustration that follows this paragraph. Refer to “Network Wiring” on page 13 before attaching the 4-position terminal block connector. Apply power after all connections have been made.

When making connections to the DM-TX-200, note the following:

- Use Crestron power supplies for Crestron equipment.
- The included cable cannot be extended.

Hardware Connections for the DM-TX-200 (Top View)

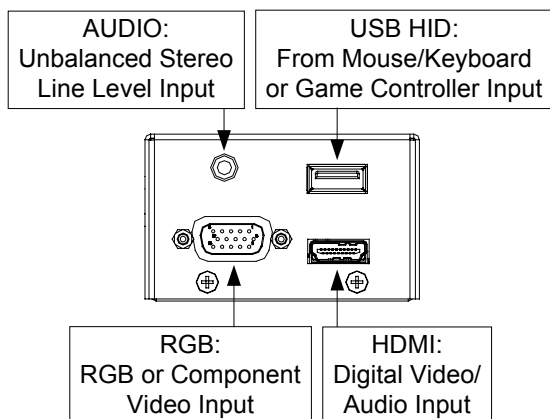

Hardware Connections for the DM-TX-200 (Bottom View)

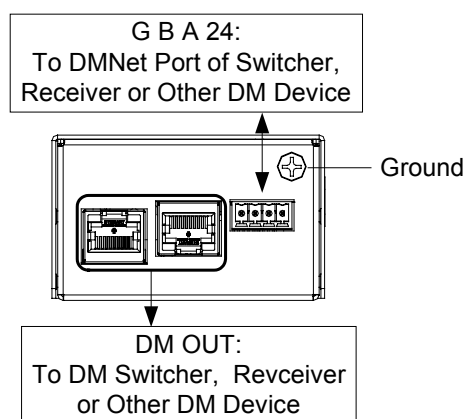

NOTE: Ensure the unit is properly grounded by connecting the chassis ground lug to an earth ground (building steel).

NOTE: To prevent overheating, do not operate this product in an area that exceeds the environmental temperature range listed in the table of specifications.

NOTE: For optimum performance, Crestron strongly recommends using DM-CBL DigitalMedia cable, available from Crestron.

NOTE: Minimum recommended length for DM-CBL DigitalMedia cable is 15 feet (~4.6 meters).

NOTE: When used without a DM switcher, the DM-TX-200 can be powered by a PW-2407-RU or any Crestron 24 Volt power supply. Power supply not included.

Programming Software

Have a question or comment about Crestron software?

Answers to frequently asked questions (FAQs) can be viewed in the Online Help section of the Crestron website. To post a question or view questions you have submitted to Crestron's True Blue Support, log in at <http://support.crestron.com>. First-time users will need to establish a user account.

Earliest Version Software Requirements for the PC

NOTE: Crestron recommends that you use the latest software to take advantage of the most recently released features. The latest software is available from the Crestron website.

Crestron has developed an assortment of Windows®-based software tools to develop a controlled DigitalMedia system. For the minimum recommended software versions, visit the Version Tracker page of the Crestron website (www.crestron.com/versiontracker).

Programming with SIMPL Windows

SIMPL Windows is Crestron's premier software for programming Crestron control systems. It is organized into two separate but equally important "Managers".

Configuration Manager

Configuration Manager is the view where programmers "build" a Crestron control system by selecting hardware from the *Device Library*.

In the example shown on the following page, the DM-TX-200 is being used in a DigitalMedia system with a DM-MD8X8 Switcher, equipped with a DMC-CAT input card. For details, refer to the latest version of the DigitalMedia Switchers Operations Guide (Doc. 6755).

1. To incorporate the DM-TX-200 into the system, drag the DM-TX-200 from the DigitalMedia | DM Transmitters folder of the *Device Library* and drop it in the *System Views*.

Locating the DM-TX-200 in the Device Library

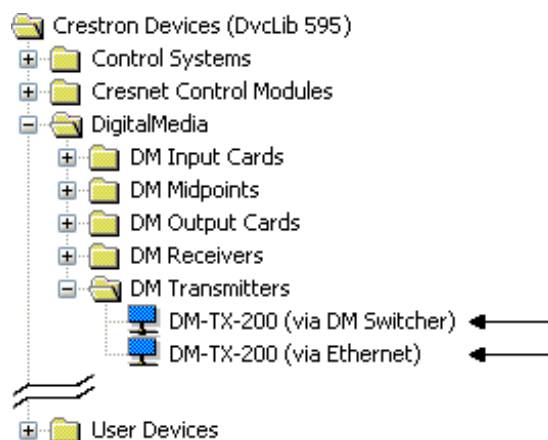

- The system tree of the control system displays the device in the appropriate slot with an IP ID as shown in the following illustration.

C2Net Device, Slot 8 (Using Input Card in DM Switcher)

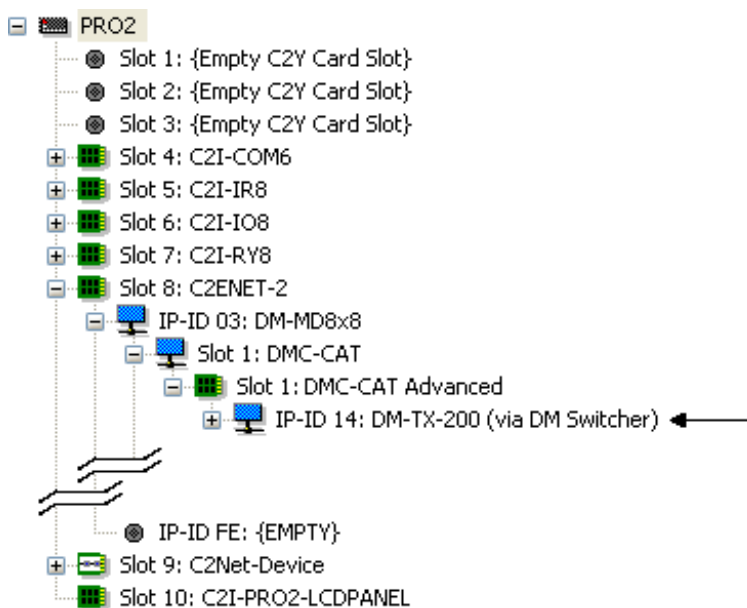

NOTE: Alternatively, the DM-TX-200 can be dragged directly to a card such as the C2ENET-2, in the Ethernet slot of the control system, when it is to be used without a DM switcher.

C2Net Device, Slot 8 (Using Ethernet Slot on Control System)

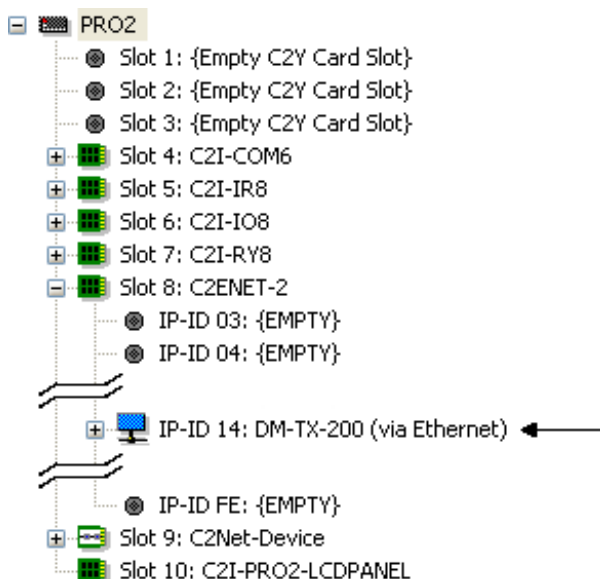

- Additional DM-TX-200 devices are assigned different IP ID numbers as they are added.
- If necessary, double click a device to open the “Device Settings” window and change the IP ID, as shown in the following figure.

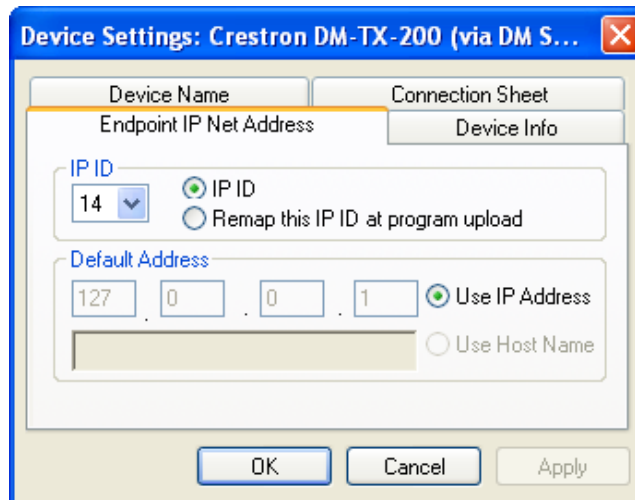
“Device Settings: Crestron DM-TX-200” Window

- The ID code specified in the SIMPL Windows program must match the IP ID of each unit. Refer to “Identity Code” on page 13

Program Manager

Program Manager is the view where programmers “program” a Crestron control system by assigning signals to symbols.

The symbol can be viewed by double clicking on the icon or dragging it into *Detail View*. Each signal in the symbol is described in the SIMPL Windows help file (**F1**).

Example Program

An example program for the DM-TX-200 is available from the Crestron website (www.crestron.com/exampleprograms).

Uploading and Upgrading

Crestron recommends using the latest programming software and that each device contains the latest firmware to take advantage of the most recently released features. However, before attempting to upload or upgrade it is necessary to establish communication. Once communication has been established, files (for example, firmware) can be transferred to the device. Finally, program checks can be performed (such as changing the device ID or creating an IP table) to ensure proper functioning.

Establishing Communication

Use Crestron Toolbox for communicating with the DM-TX-200; refer to the Crestron Toolbox help file for details. There is a single method of communication: indirect communication. This can be accomplished by using the DM-TX-200 with a DM switcher (sold separately) or by using the DM-TX-200 in a standalone setup with a DM-RMC-100 (sold separately).

Via a DM Switcher

Indirect Communication via a DM Switcher

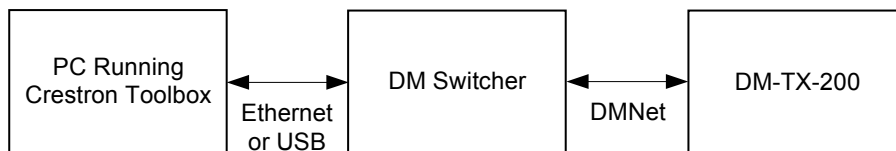

DM-TX-200 connects to DigitalMedia switcher via DMNet.

NOTE: In the SIMPL™ Windows program, when the DM-TX-200 is dropped onto an input card of a DM switcher, its IP ID is assigned automatically and does not require additional programming or configuration. Use the information below when the DM-TX-200 is dropped directly into an Ethernet slot on the control system in SIMPL Windows, without a DM switcher.

Via a DM-RMC-100

Indirect Communication via a DM-RMC-100

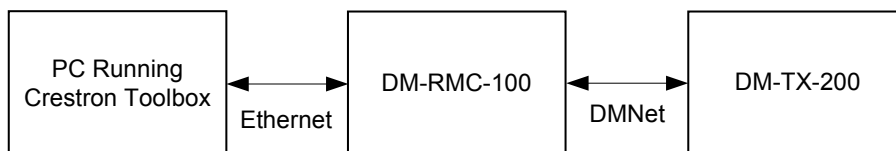

The DM-TX-200 connects to PC via Ethernet:

1. Confirm Ethernet connection between DM-RMC-100 and PC. If connecting through a hub or router, use CAT5 straight through cables with 8-pin RJ-45 connectors. Alternatively, use a CAT5 crossover cable to connect the two LAN ports directly without using a hub or router.
2. By default, DHCP is enabled. Use the Device Discovery Tool in Crestron Toolbox to find the IP address of the DM-TX-200. To change the IP

configuration, from Crestron Toolbox, display the “System Info” window (click the  icon) and select the DM-TX-200 entry from the Address Book. Select **Functions | Ethernet Addressing** and enter the new IP address, IP mask and default router of the DM-TX-200.

NOTE: If the DM-TX-200 is in a non-DHCP environment, a default IP address (192.168.1.232) can be assigned by holding down its **SETUP** button while applying power. This IP address will overwrite any previous settings and will remain until it is changed.

3. Use the Address Book in Crestron Toolbox to create an entry for the DM-TX-200 with the DM-TX-200’s TCP/IP communication parameters.
4. Display the “System Info” window (click the  icon) and select the DM-TX-200 entry from the Address Book.

Firmware

Firmware files may be distributed from programmers to installers or from Crestron to dealers. Firmware upgrades are available from the Crestron website as new features are developed after product releases. For details on upgrading, refer to the Crestron Toolbox help file.

Check the Crestron website to find the latest firmware. (New users may be required to register to obtain access to certain areas of the site, including the FTP site.)

To upgrade DM-TX-200 firmware:

1. If the DM-TX-200 is being used with a DM switcher, use the Device Discovery Tool in Crestron Toolbox to find the switcher’s IP address. If the DM-TX-200 is being used standalone (with a DM-RMC-100) use the Device Discovery Tool to find the DM-TX-200’s IP address. Add this IP address (either the switcher’s or the DM-TX-200’s, depending on how your unit is connected) to the Address Book in Toolbox.

NOTE: The .puf file for upgrading firmware can be pointed to the IP address of the DM switcher or to the IP address of the DM device (DM-TX-200). When it is pointed to the DM switcher, all DM devices connected to the switcher, including the DM-TX-200, will be upgraded (except for fiber devices). When it is pointed to a DM-TX-200 (in a standalone setup), only the devices connected to the DM-TX-200 will be upgraded (including a DM-DR or DM-RMC-100).

2. Download the appropriate .puf file from the Crestron website.
3. Double-click the .puf file. The Toolbox Address Book will open.
4. From the list in the Address Book, select the DM switcher (if the DM-TX-200 is being used with a switcher) or select the DM-TX-200 (if it is being used with a DM-RMC-100) and click **OK**.
5. From the DM device list, select the item(s) to upgrade using the checkboxes (if they have not already been selected automatically).
6. Click **Update**.
7. After the process is complete, click **Recheck** to verify the upgrade.

IP Configuration

For Ethernet connections, display the “System Info” window (click the  icon) and select the **Functions** menu to display actions that can be performed on the DM-TX-200.

When using the DM-TX-200 with a DM-RMC-100 (i.e. without a DM switcher), be sure to use Crestron Toolbox to create the DM-TX-200 IP table.

1. Use the Device Discovery Tool to find the IP address of the DM-TX-200. Then, in the Toolbox, display the “System Info” window and select the DM-TX-200 entry from the Address Book.
2. Select **Functions | IP Table Setup**.
3. Add, modify or delete entries in the IP table. The DM-TX-200 can have only one IP table entry.
4. A defined IP table can be saved to a file or sent to the device.

DM Tool

In the Crestron Toolbox Address Book, select the DM-TX-200. Then use the DM Tool to configure EDID, HDCP or to troubleshoot AV on the DM-TX-200. Refer to the help file for additional information.

DM Tool

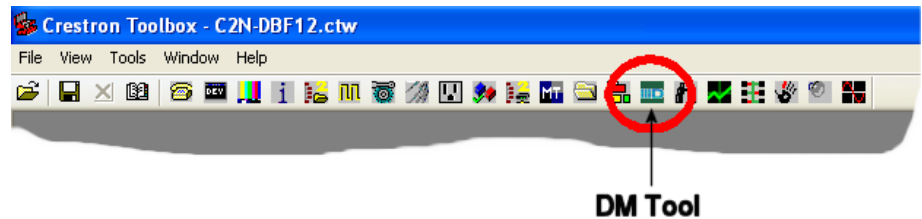

Problem Solving

Troubleshooting

The following table provides corrective action for possible trouble situations. If further assistance is required, please contact a Crestron customer service representative.

DM-TX-200 Troubleshooting

TROUBLE	POSSIBLE CAUSE(S)	CORRECTIVE ACTION
Device does not function.	Device is not communicating with the network.	Use Crestron Toolbox to poll the network. Verify network connection to the device.
	Device is not receiving power from a Crestron power source.	Use the provided Crestron power source. Verify connections.
	Device is not receiving sufficient power.	Use the DMNet Power Calculator to help calculate how much power is needed for the system.
PWR LED does not illuminate.	Device is not receiving power.	Verify PWR connections are properly attached.
DM LINK LED does not illuminate.	Device is not transmitting DMNet signal.	Verify DM OUT connections are properly attached.
Loss of functionality due to electrostatic discharge.	Improper grounding.	Check that all ground connections have been made properly.

Check Network Wiring

Use the Right Wire

In order to ensure optimum performance over the full range of your installation topology, Crestron Certified Wire and only Crestron Certified Wire may be used. Failure to do so may incur additional charges if support is required to identify performance deficiencies because of using improper wire.

Calculate Power

CAUTION: Use only Crestron power supplies for Crestron equipment. Failure to do so could cause equipment damage or void the Crestron warranty.

CAUTION: Provide sufficient power to the system. Insufficient power can lead to unpredictable results or damage to the equipment. The **EIG** connector on the DM switcher is used to bring in external power. Additional power is rarely required as switchers provide enough power for their maximum configuration of room controllers and repeaters. Please use the DMNet Power Calculator to help calculate how much power is needed for the system (www.crestron.com/calculators).

Refer to the following for maximum DM cable lengths.

Maximum DM Cable Length

Cable Type:	DM-CBL DigitalMedia Cable	
	Maximum length without, between, before or after repeaters	Maximum total length using up to 2 repeaters
Resolution:		
720p, 1080i, 1080p24	200 ft (60 m)	450 ft (137 m)
1024x768 @75 Hz	200 ft (60 m)	450 ft (137 m)
1080p60	150 ft (45 m)	450 ft (137 m)
1280x1024 @75 Hz	150 ft (45 m)	450 ft (137 m)
1920x1200 @60 Hz	150 ft (45 m)	450 ft (137 m)
1600x1200 @60 Hz	125 ft (38 m)	375 ft (114 m)
1080p60 Deep Color	Not supported	

NOTE: All Crestron certified DMNet wiring must consist of two twisted pairs. One twisted pair is the +24V conductor and the GND conductor and the other twisted pair is the A conductor and the B conductor.

Reference Documents

The latest version of all documents mentioned within the guide can be obtained from the Crestron website (www.crestron.com/manuals). This link will provide a list of product manuals arranged in alphabetical order by model number.

List of Related Reference Documents

DOCUMENT TITLE
Crestron DigitalMedia Design Guide
DigitalMedia Switchers Operations Guide

Further Inquiries

If you cannot locate specific information or have questions after reviewing this guide, please take advantage of Crestron's award winning customer service team by calling Crestron at 1-888-CRESTRON [1-888-273-7876].

You can also log onto the online help section of the Crestron website (www.crestron.com/onlinehelp) to ask questions about Crestron products. First-time users will need to establish a user account to fully benefit from all available features.

Future Updates

As Crestron improves functions, adds new features and extends the capabilities of the DM-TX-200, additional information may be made available as manual updates. These updates are solely electronic and serve as intermediary supplements prior to the release of a complete technical documentation revision.

Check the Crestron website periodically for manual update availability and its relevance. Updates are identified as an “Addendum” in the Download column.

Return and Warranty Policies

Merchandise Returns / Repair Service

1. No merchandise may be returned for credit, exchange or service without prior authorization from CRESTRON. To obtain warranty service for CRESTRON products, contact an authorized CRESTRON dealer. Only authorized CRESTRON dealers may contact the factory and request an RMA (Return Merchandise Authorization) number. Enclose a note specifying the nature of the problem, name and phone number of contact person, RMA number and return address.
2. Products may be returned for credit, exchange or service with a CRESTRON Return Merchandise Authorization (RMA) number. Authorized returns must be shipped freight prepaid to CRESTRON, 6 Volvo Drive, Rockleigh, N.J. or its authorized subsidiaries, with RMA number clearly marked on the outside of all cartons. Shipments arriving freight collect or without an RMA number shall be subject to refusal. CRESTRON reserves the right in its sole and absolute discretion to charge a 15% restocking fee plus shipping costs on any products returned with an RMA.
3. Return freight charges following repair of items under warranty shall be paid by CRESTRON, shipping by standard ground carrier. In the event repairs are found to be non-warranty, return freight costs shall be paid by the purchaser.

CRESTRON Limited Warranty

CRESTRON ELECTRONICS, Inc. warrants its products to be free from manufacturing defects in materials and workmanship under normal use for a period of three (3) years from the date of purchase from CRESTRON, with the following exceptions: disk drives and any other moving or rotating mechanical parts, pan/tilt heads and power supplies are covered for a period of one (1) year; touchscreen display and overlay components are covered for 90 days; batteries and incandescent lamps are not covered.

This warranty extends to products purchased directly from CRESTRON or an authorized CRESTRON dealer. Purchasers should inquire of the dealer regarding the nature and extent of the dealer's warranty, if any.

CRESTRON shall not be liable to honor the terms of this warranty if the product has been used in any application other than that for which it was intended or if it has been subjected to misuse, accidental damage, modification or improper installation procedures. Furthermore, this warranty does not cover any product that has had the serial number altered, defaced or removed.

This warranty shall be the sole and exclusive remedy to the original purchaser. In no event shall CRESTRON be liable for incidental or consequential damages of any kind (property or economic damages inclusive) arising from the sale or use of this equipment. CRESTRON is not liable for any claim made by a third party or made by the purchaser for a third party.

CRESTRON shall, at its option, repair or replace any product found defective, without charge for parts or labor. Repaired or replaced equipment and parts supplied under this warranty shall be covered only by the unexpired portion of the warranty.

Except as expressly set forth in this warranty, CRESTRON makes no other warranties, expressed or implied, nor authorizes any other party to offer any warranty, including any implied warranties of merchantability or fitness for a particular purpose. Any implied warranties that may be imposed by law are limited to the terms of this limited warranty. This warranty statement supersedes all previous warranties.

Trademark Information

All brand names, product names and trademarks are the sole property of their respective owners. Windows is a registered trademark of Microsoft Corporation. Windows95/98/Me/XP/Vista/7 and WindowsNT/2000 are trademarks of Microsoft Corporation.

GNU General Public License

Version 2, June 1991

Copyright (C) 1989, 1991 Free Software Foundation, Inc., 51 Franklin Street, Fifth Floor, Boston, MA 02110-1301 USA
Everyone is permitted to copy and distribute verbatim copies of this license document but changing it is not allowed.

PREAMBLE

The licenses for most software are designed to take away your freedom to share and change it. By contrast, the GNU General Public License is intended to guarantee your freedom to share and change free software--to make sure the software is free for all its users. This General Public License applies to most of the Free Software Foundation's software and to any other program whose authors commit to using it. (Some other Free Software Foundation software is covered by the GNU Lesser General Public License instead.) You can apply it to your programs too.

When we speak of free software, we are referring to freedom, not price. Our General Public Licenses are designed to make sure that you have the freedom to distribute copies of free software (and charge for this service if you wish), that you receive source code or can get it if you want it, that you can change the software or use pieces of it in new free programs and that you know you can do these things.

To protect your rights, we need to make restrictions that forbid anyone to deny you these rights or to ask you to surrender the rights. These restrictions translate to certain responsibilities for you if you distribute copies of the software or if you modify it.

For example, if you distribute copies of such a program, whether gratis or for a fee, you must give the recipients all the rights that you have. You must make sure that they too receive or can get the source code. And you must show them these terms so they know their rights.

We protect your rights with two steps: (1) copyright the software, and (2) offer you this license which gives you legal permission to copy, distribute and/or modify the software.

Also, for each author's protection and ours, we want to make certain that everyone understands that there is no warranty for this free software. If the software is modified by someone else and passed on, we want its recipients to know that what they have is not the original, so that any problems introduced by others will not reflect on the original authors' reputations.

Finally, any free program is threatened constantly by software patents. We wish to avoid the danger that redistributors of a free program will individually obtain patent licenses, in effect making the program proprietary. To prevent this, we have made it clear that any patent must be licensed for everyone's free use or not licensed at all.

The precise terms and conditions for copying, distribution and modification follow.

GNU GENERAL PUBLIC LICENSE TERMS AND CONDITIONS FOR COPYING, DISTRIBUTION AND MODIFICATION

0. This License applies to any program or other work which contains a notice placed by the copyright holder saying it may be distributed under the terms of this General Public License. The "Program" below refers to any such program or work, and a "work based on the Program" means either the Program or any derivative work under copyright law: that is to say, a work containing the Program or a portion of it, either verbatim or with modifications and/or translated into another language. (Hereinafter, translation is included without limitation in the term "modification".) Each licensee is addressed as "you".

Activities other than copying, distribution and modification are not covered by this License; they are outside its scope. The act of running the Program is not restricted, and the output from the Program is covered only if its contents constitute a work based on the Program (independent of having been made by running the Program). Whether that is true depends on what the Program does.

1. You may copy and distribute verbatim copies of the Program's source code as you receive it, in any medium, provided that you conspicuously and appropriately publish on each copy an appropriate copyright notice and disclaimer of warranty; keep intact all the notices that refer to this License and to the absence of any warranty; and give any other recipients of the Program a copy of this License along with the Program.

You may charge a fee for the physical act of transferring a copy and you may at your option offer warranty protection in exchange for a fee.

2. You may modify your copy or copies of the Program or any portion of it, thus forming a work based on the Program, and copy and distribute such modifications or work under the terms of Section 1 above, provided that you also meet all of these conditions:

- a) You must cause the modified files to carry prominent notices stating that you changed the files and the date of any change.
- b) You must cause any work that you distribute or publish, that in whole or in part contains or is derived from the Program or any part thereof, to be licensed as a whole at no charge to all third parties under the terms of this License.
- c) If the modified program normally reads commands interactively when run, you must cause it, when started running for such interactive use in the most ordinary way, to print or display an announcement including an appropriate copyright notice and a notice that there is no warranty (or else, saying that you provide a warranty) and that users may redistribute the program under these conditions, and telling the user how to view a copy of this License. (Exception: if the Program itself is interactive but does not normally print such an announcement, your work based on the Program is not required to print an announcement.)

These requirements apply to the modified work as a whole. If identifiable sections of that work are not derived from the Program and can be reasonably considered independent and separate works in themselves, then this License and its terms do not apply to those sections when you distribute them as separate works. But when you distribute the same sections as part of a whole which is a work based on the Program, the distribution of the whole must be on the terms of this License, whose permissions for other licensees extend to the entire whole and thus to each and every part regardless of who wrote it.

Thus, it is not the intent of this section to claim rights or contest your rights to work written entirely by you; rather, the intent is to exercise the right to control the distribution of derivative or collective works based on the Program.

In addition, mere aggregation of another work not based on the Program with the Program (or with a work based on the Program) on a volume of a storage or distribution medium does not bring the other work under the scope of this License.

3. You may copy and distribute the Program (or a work based on it, under Section 2) in object code or executable form under the terms of Sections 1 and 2 above provided that you also do one of the following:

- a) Accompany it with the complete corresponding machine-readable source code, which must be distributed under the terms of Sections 1 and 2 above on a medium customarily used for software interchange; or,
- b) Accompany it with a written offer, valid for at least three years, to give any third party, for a charge no more than your cost of physically performing source distribution, a complete machine-readable copy of the corresponding source code, to be distributed under the terms of Sections 1 and 2 above on a medium customarily used for software interchange; or,
- c) Accompany it with the information you received as to the offer to distribute corresponding source code. (This alternative is allowed only for noncommercial distribution and only if you received the program in object code or executable form with such an offer, in accord with Subsection b above.)

The source code for a work means the preferred form of the work for making modifications to it. For an executable work, complete source code means all the source code for all modules it contains, plus any associated interface definition files, plus the scripts used to control compilation and installation of the executable. However, as a special exception, the source code distributed need not include anything that is normally distributed (in either source or binary form) with the major components (compiler, kernel and so on) of the operating system on which the executable runs, unless that component itself accompanies the executable.

If distribution of executable or object code is made by offering access to copy from a designated place, then offering equivalent access to copy the source code from the same place counts as distribution of the source code, even though third parties are not compelled to copy the source along with the object code.

4. You may not copy, modify, sublicense or distribute the Program except as expressly provided under this License. Any attempt otherwise to copy, modify, sublicense or distribute the Program is void and will automatically terminate your rights under this License. However, parties who have received copies or rights, from you under this License will not have their licenses terminated so long as such parties remain in full compliance.

5. You are not required to accept this License, since you have not signed it. However, nothing else grants you permission to modify or distribute the Program or its derivative works. These actions are prohibited by law if you do not accept this License. Therefore, by

modifying or distributing the Program (or any work based on the Program), you indicate your acceptance of this License to do so and all its terms and conditions for copying, distributing or modifying the Program or works based on it.

6. Each time you redistribute the Program (or any work based on the Program), the recipient automatically receives a license from the original licensor to copy, distribute or modify the Program subject to these terms and conditions. You may not impose any further restrictions on the recipients' exercise of the rights granted herein. You are not responsible for enforcing compliance by third parties to this License.

7. If, as a consequence of a court judgment or allegation of patent infringement or for any other reason (not limited to patent issues), conditions are imposed on you (whether by court order, agreement or otherwise) that contradict the conditions of this License, they do not excuse you from the conditions of this License. If you cannot distribute so as to satisfy simultaneously your obligations under this License and any other pertinent obligations, then as a consequence you may not distribute the Program at all. For example, if a patent license would not permit royalty-free redistribution of the Program by all those who receive copies directly or indirectly through you, then the only way you could satisfy both it and this License would be to refrain entirely from distribution of the Program.

If any portion of this section is held invalid or unenforceable under any particular circumstance, the balance of the section is intended to apply and the section as a whole is intended to apply in other circumstances.

It is not the purpose of this section to induce you to infringe any patents or other property right claims or to contest validity of any such claims; this section has the sole purpose of protecting the integrity of the free software distribution system, which is implemented by public license practices. Many people have made generous contributions to the wide range of software distributed through that system in reliance on consistent application of that system; it is up to the author/donor to decide if he or she is willing to distribute software through any other system and a licensee cannot impose that choice.

This section is intended to make thoroughly clear what is believed to be a consequence of the rest of this License.

8. If the distribution and/or use of the Program is restricted in certain countries either by patents or by copyrighted interfaces, the original copyright holder who places the Program under this License may add an explicit geographical distribution limitation excluding those countries, so that distribution is permitted only in or among countries not thus excluded. In such case, this License incorporates the limitation as if written in the body of this License.

9. The Free Software Foundation may publish revised and/or new versions of the General Public License from time to time. Such new versions will be similar in spirit to the present version but may differ in detail to address new problems or concerns.

Each version is given a distinguishing version number. If the Program specifies a version number of this License which applies to it and "any later version", you have the option of following the terms and conditions either of that version or of any later version published by the Free Software Foundation. If the Program does not specify a version number of this License, you may choose any version ever published by the Free Software Foundation.

10. If you wish to incorporate parts of the Program into other free programs whose distribution conditions are different, write to the author to ask for permission. For software which is copyrighted by the Free Software Foundation, write to the Free Software Foundation; we sometimes make exceptions for this. Our decision will be guided by the two goals of preserving the free status of all derivatives of our free software and of promoting the sharing and reuse of software generally.

NO WARRANTY

11. BECAUSE THE PROGRAM IS LICENSED FREE OF CHARGE, THERE IS NO WARRANTY FOR THE PROGRAM, TO THE EXTENT PERMITTED BY APPLICABLE LAW. EXCEPT WHEN OTHERWISE STATED IN WRITING THE COPYRIGHT HOLDERS AND/OR OTHER PARTIES PROVIDE THE PROGRAM "AS IS" WITHOUT WARRANTY OF ANY KIND, EITHER EXPRESSED OR IMPLIED, INCLUDING BUT NOT LIMITED TO, THE IMPLIED WARRANTIES OF MERCHANTABILITY AND FITNESS FOR A PARTICULAR PURPOSE. THE ENTIRE RISK AS TO THE QUALITY AND PERFORMANCE OF THE PROGRAM IS WITH YOU. SHOULD THE PROGRAM PROVE DEFECTIVE, YOU ASSUME THE COST OF ALL NECESSARY SERVICING, REPAIR OR CORRECTION.

12. IN NO EVENT UNLESS REQUIRED BY APPLICABLE LAW OR AGREED TO IN WRITING WILL ANY COPYRIGHT HOLDER OR ANY OTHER PARTY WHO MAY MODIFY AND/OR REDISTRIBUTE THE PROGRAM AS PERMITTED ABOVE, BE LIABLE TO YOU FOR DAMAGES, INCLUDING ANY GENERAL, SPECIAL, INCIDENTAL OR CONSEQUENTIAL DAMAGES ARISING OUT OF THE USE OR INABILITY TO USE THE PROGRAM (INCLUDING BUT NOT LIMITED TO LOSS OF DATA OR DATA BEING RENDERED INACCURATE OR LOSSES SUSTAINED BY YOU OR THIRD PARTIES OR A FAILURE OF THE PROGRAM TO OPERATE WITH ANY OTHER PROGRAMS), EVEN IF SUCH HOLDER OR OTHER PARTY HAS BEEN ADVISED OF THE POSSIBILITY OF SUCH DAMAGES.



Crestron Electronics, Inc.
15 Volvo Drive Rockleigh, NJ 07647
Tel: 888.CRESTRON
Fax: 201.767.7576
www.crestron.com

Operations & Installation Guide – DOC. 6741C
(2024102)
04.10
Specifications subject to
change without notice.