

WESLO[®]

CADENCE 16.0

Model No. WETL39710.0

Serial No. _____

Write the serial number in the space above for future reference.

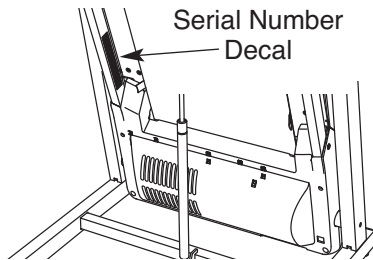

USER'S MANUAL

QUESTIONS?

If you have questions, or if there are missing parts, please contact us:

UK

Call: 08457 089 009

From Ireland: 053 92 36102

Website: www.iconsupport.eu

Write:

ICON Health & Fitness, Ltd.
c/o HI Group PLC, Express Way
Whitwood, West Yorkshire
WF10 5QJ

UK

AUSTRALIA

Call: 1-800-237-173

E-mail:

australiacc@iconfitness.com

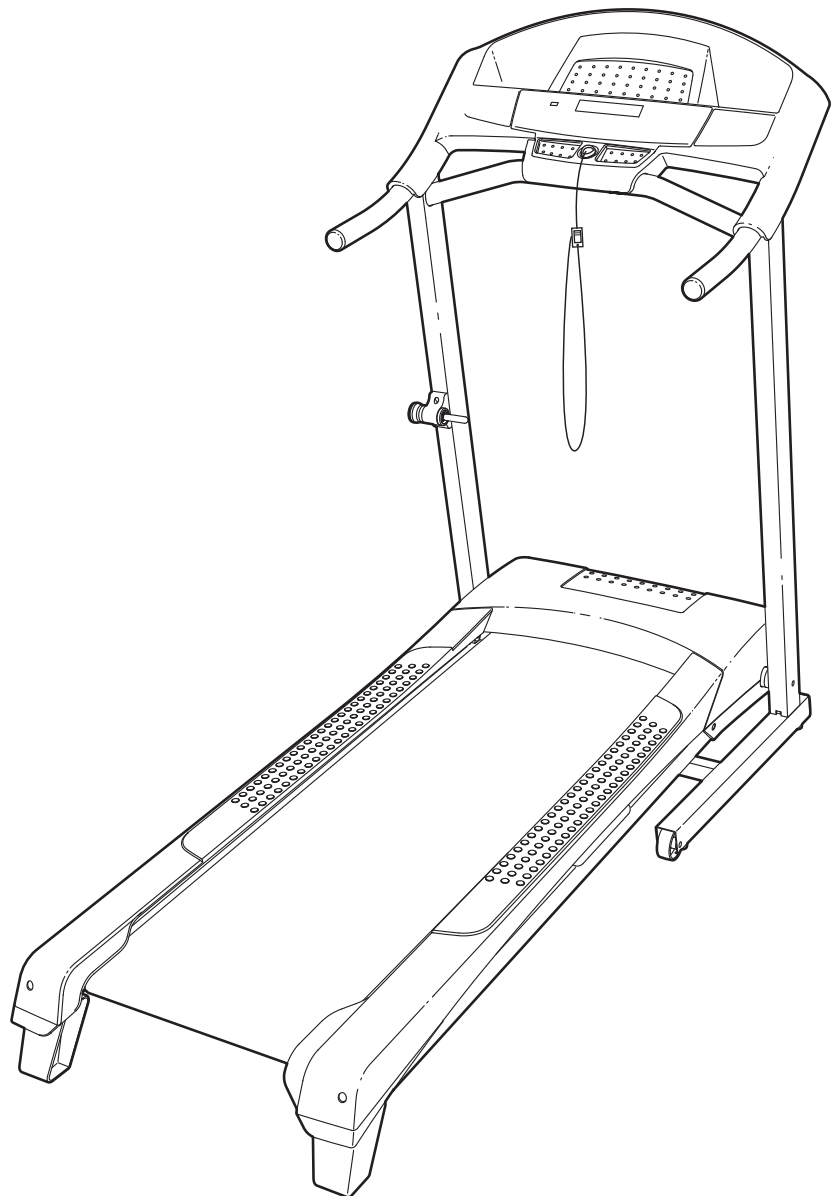

CAUTION

Read all precautions and instructions in this manual before using this equipment. Save this manual for future reference.

www.iconeurope.com

TABLE OF CONTENTS

WARNING DECAL PLACEMENT 2

IMPORTANT PRECAUTIONS 3

BEFORE YOU BEGIN 5

ASSEMBLY 6

OPERATION AND ADJUSTMENT 9

HOW TO FOLD AND MOVE THE TREADMILL 15

TROUBLESHOOTING 16

EXERCISE GUIDELINES 19

PART LIST 20

EXPLODED DRAWING 21

ORDERING REPLACEMENT PARTS Back Cover



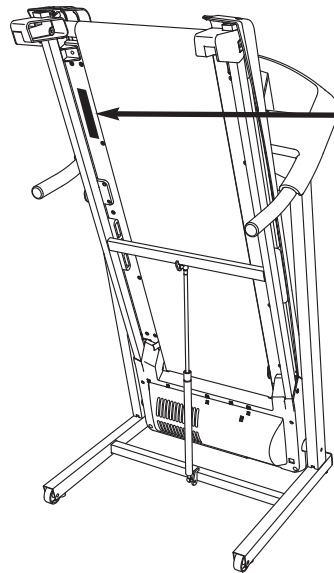

RECYCLING INFORMATION Back Cover

WARNING DECAL PLACEMENT

This drawing shows the location(s) of the warning decal(s). **If a decal is missing or illegible, call the telephone number on the front cover of this manual and request a free replacement decal. Apply the decal in the location shown.** Note: The decal(s) may not be shown at actual size.



▲ WARNING:
Protect yourself and others from risk of serious injury. Read the user's manual and :

-  •Stand only on the side rails when starting or stopping treadmill.
- Change speed in small increments.
- Hold handrails to prevent falling, and always wear the safety clip while operating treadmill.
- Stop if you feel faint, dizzy, or short of breath.
- Fully engage storage latch before treadmill is moved or stored.
- Reduce incline to its lowest level before folding treadmill into storage position.
-  •Never allow children on or around treadmill.
- Remove key when not in use.
-  •Keep clothing, fingers, and hair away from moving belt.
- Never try to adjust or fix the belt while it is moving.
-  •Always wear athletic shoes while operating treadmill.

IMPORTANT PRECAUTIONS

⚠ WARNING: To reduce the risk of serious injury, read all important precautions and instructions in this manual and all warnings on your treadmill before using your treadmill. ICON assumes no responsibility for personal injury or property damage sustained by or through the use of this product.

1. Before beginning this or any exercise program, consult your physician. This is especially important for persons over age 35 or persons with pre-existing health problems.
2. It is the responsibility of the owner to ensure that all users of this treadmill are adequately informed of all warnings and precautions.
3. Use the treadmill only as described.
4. Place the treadmill on a level surface, with at least 8 ft. (2.4 m) of clearance behind it and 2 ft. (0.6 m) on each side. Do not place the treadmill on any surface that blocks air openings. To protect the floor or carpet from damage, place a mat under the treadmill.
5. Keep the treadmill indoors, away from moisture and dust. Do not put the treadmill in a garage or covered patio, or near water.
6. Do not operate the treadmill where aerosol products are used or where oxygen is being administered.
7. Keep children under age 12 and pets away from the treadmill at all times.
8. The treadmill should not be used by persons weighing more than 265 lbs. (120 kg).
9. Never allow more than one person on the treadmill at a time.
10. Wear appropriate exercise clothes when using the treadmill. Do not wear loose clothes that could become caught in the treadmill. Athletic support clothes are recommended for both men and women. *Always wear athletic shoes; never use the treadmill with bare feet, wearing only stockings, or in sandals.*
11. When connecting the power cord (see page 9), plug the power cord into an earthed circuit. No other appliance should be on the same circuit. When replacing the fuse in the power cord adapter, insert an ASTA-approved BS1362, 13-amp fuse into the fuse carrier.
12. If an extension cord is needed, use only a 3-conductor, 14-gauge (1 mm²) cord that is no longer than 5 ft. (1.5 m).
13. Keep the power cord away from heated surfaces.
14. Never move the walking belt while the power is turned off. Do not operate the treadmill if the power cord or plug is damaged, or if the treadmill is not working properly. (See TROUBLESHOOTING on page 16 if the treadmill is not working properly.)
15. Read, understand, and test the emergency stop procedure before using the treadmill (see HOW TO TURN ON THE POWER on page 11).
16. Never start the treadmill while you are standing on the walking belt. Always hold the handrails while using the treadmill.
17. The pulse sensor is not a medical device. Various factors, including your movement, may affect the accuracy of heart rate readings. The pulse sensor is intended only as an exercise aid in determining heart rate trends in general.
18. The treadmill is capable of high speeds. Adjust the speed in small increments to avoid sudden jumps in speed.

19. Never leave the treadmill unattended while it is running. Always remove the key, unplug the power cord, and press the power switch to the off position when the treadmill is not in use. (See the drawing on page 5 for the location of the power switch.)
20. Do not attempt to raise, lower, or move the treadmill until it is properly assembled. (See ASSEMBLY on page 6 and HOW TO FOLD AND MOVE THE TREADMILL on page 15.) You must be able to safely lift 45 lbs. (20 kg) to raise, lower, or move the treadmill.
21. When folding or moving the treadmill, make sure that the storage latch is holding the frame securely in the storage position.
22. Do not change the incline of the treadmill by placing objects under the treadmill.
23. Inspect and properly tighten all parts of the treadmill regularly.
24. Never drop or insert any object into any opening on the treadmill.
25. **DANGER:** Always unplug the power cord immediately after use, before cleaning the treadmill, and before performing the maintenance and adjustment procedures described in this manual. Never remove the motor hood unless instructed to do so by an authorized service representative. Servicing other than the procedures in this manual should be performed by an authorized service representative only.
26. This treadmill is intended for in-home use only. Do not use this treadmill in any commercial, rental, or institutional setting.
27. Over exercising may result in serious injury or death. If you feel faint or if you experience pain while exercising, stop immediately and cool down.

SAVE THESE INSTRUCTIONS

BEFORE YOU BEGIN

Thank you for selecting the new WESLO® CADENCE 16.0 treadmill. The CADENCE 16.0 treadmill offers a selection of features designed to make your workouts at home more effective. And when you're not exercising, the unique treadmill can be folded up, requiring less than half the floor space of other treadmills.

For your benefit, read this manual carefully before using the treadmill. If you have questions after read-

ing this manual, please see the front cover of this manual. To help us assist you, note the product model number and serial number before contacting us. The model number and the location of the serial number decal are shown on the front cover of this manual.

Before reading further, please review the drawing below and familiarize yourself with the labeled parts.

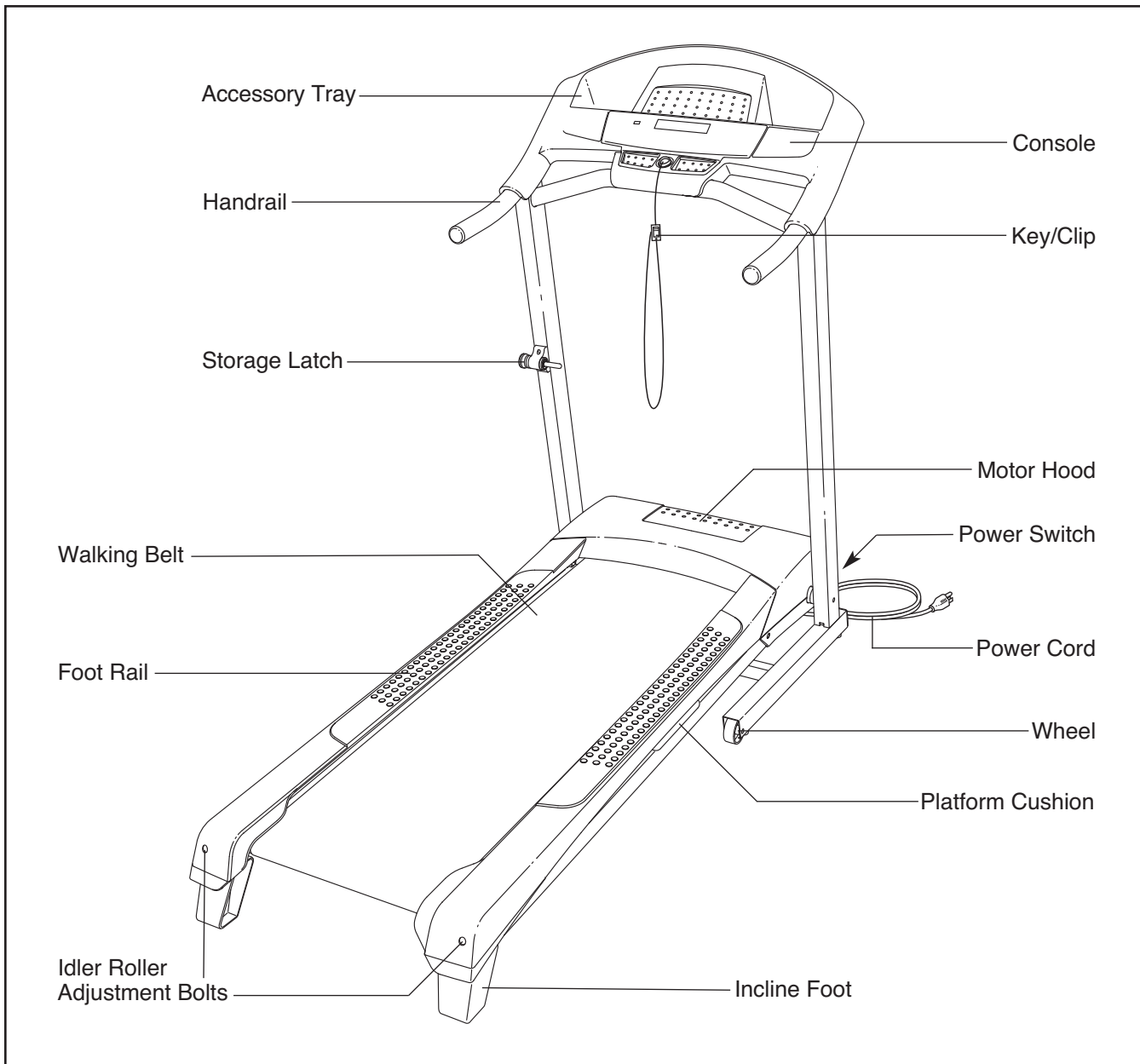

ASSEMBLY

Assembly requires two persons. Set the treadmill in a cleared area and remove all packing materials; **do not dispose of the packing materials until assembly is completed.** Note: The underside of the treadmill walking belt is coated with high-performance lubricant. During shipping, some lubricant may be transferred to the top of the walking belt or the shipping carton. This does not affect treadmill performance. If there is lubricant on top of the walking belt, simply wipe off the lubricant with a soft cloth and a mild, non-abrasive cleaner.

Assembly requires the included hex keys  and your own Phillips screwdriver , standard screwdriver , and needlenose pliers .

Use the drawings below to identify the assembly hardware. The number in parentheses below each drawing is the key number of the part, from the PART LIST near the end of this manual. The number after the parentheses is the quantity needed for assembly. **Note: Some small parts may have been pre-assembled. To avoid damaging parts, do not use power tools for assembly. Extra hardware may be included.**

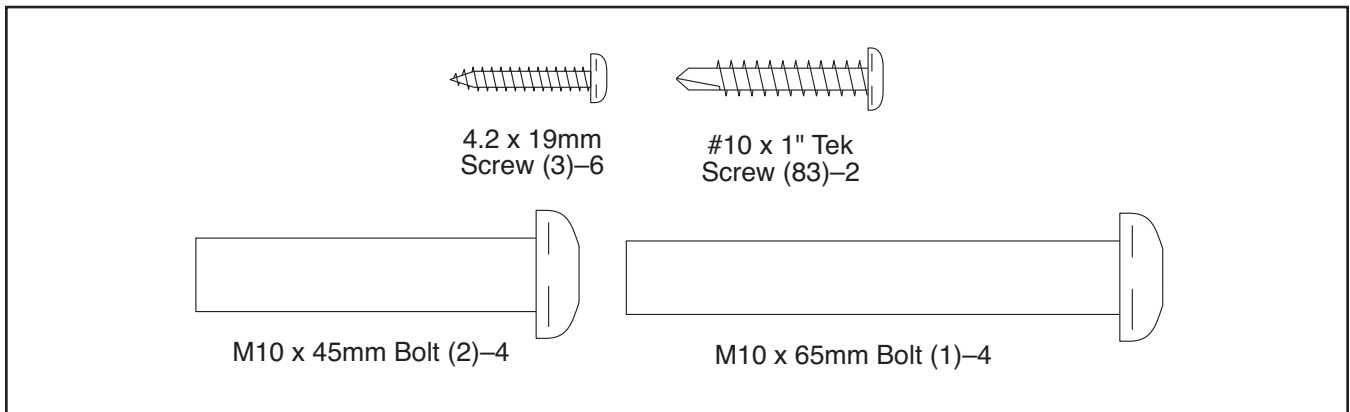

1. Make sure that the power cord is unplugged.

With the help of a second person, carefully tip the treadmill onto its left side. Unfold the Frame (50) away from the Uprights (73). Do not lean on the Uprights.

Orient the Base (80) as shown. Attach the Base to the Uprights (73) with four M10 x 65mm Bolts (1). **Start all four Bolts, and then tighten each of them.**

Raise the Uprights (73), so that the Base (80) is flat on the floor.

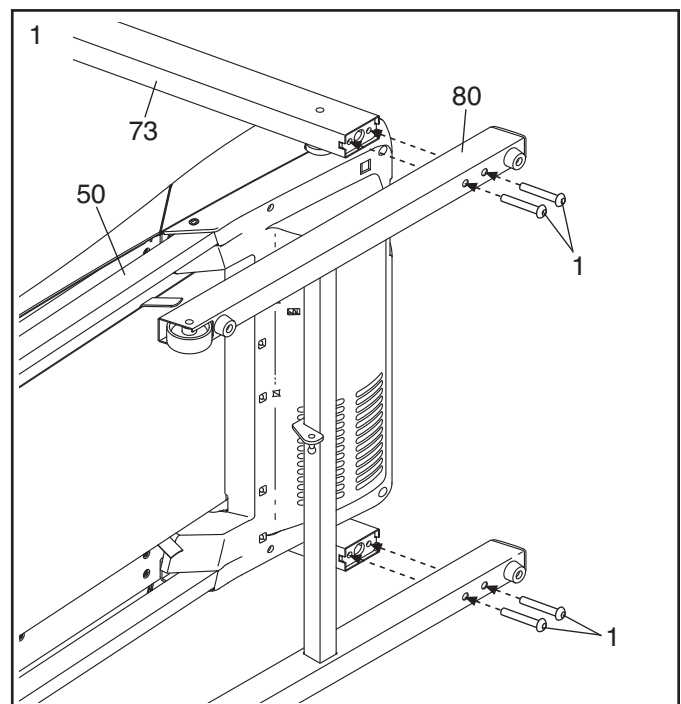

2. Attach the Handrails (69) to the Uprights (73) with four M10 x 45mm Bolts (2). **Start all four Bolts, and then tighten each of them.**

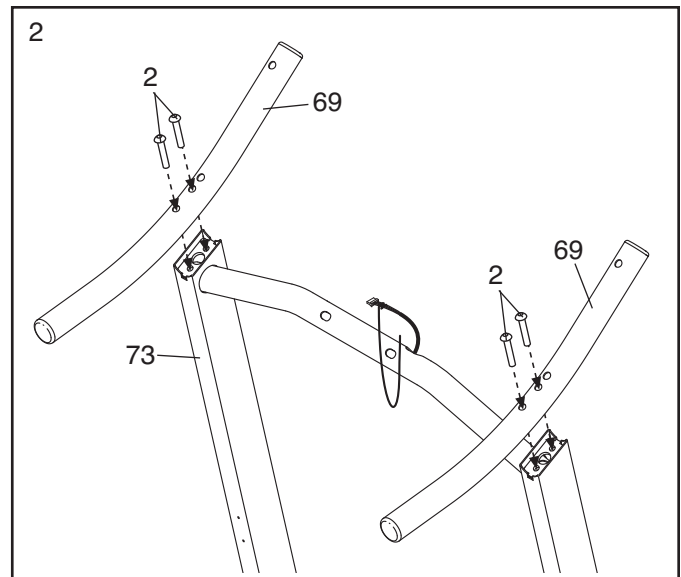

3. With the help of a second person, hold the console assembly near the Uprights (73). Remove the tie from the Upright Wire (71).

Connect the Upright Wire (71) to the console wire. **See the inset drawing. The connectors should slide together easily and snap into place.** If they do not, turn one connector and try again. **IF YOU DO NOT CONNECT THE CONNECTORS PROPERLY, THE CONSOLE MAY BECOME DAMAGED WHEN YOU TURN ON THE POWER.** Insert the connectors and the excess wire into the crossbar on the Uprights (73).

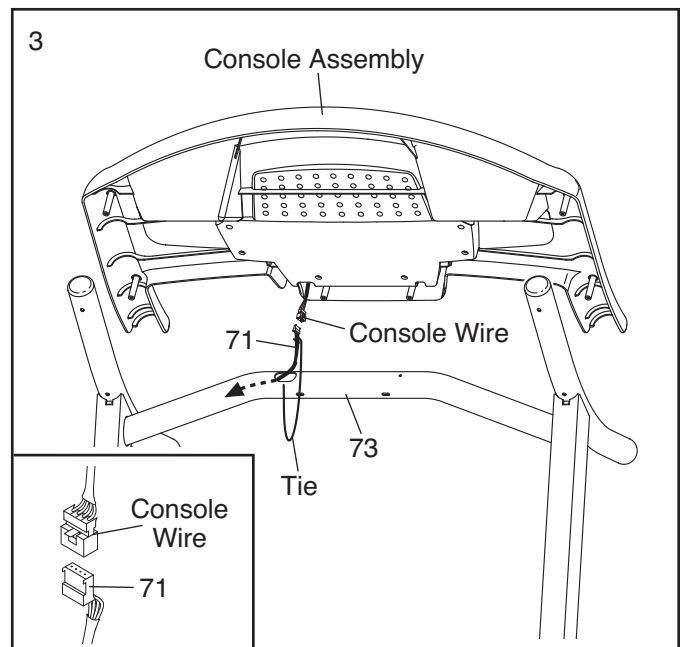

4. Attach the console assembly to the Uprights (73) and the Handrails (69) with six M4.2 x 19mm Screws (3). **Be careful not to pinch the wires.**

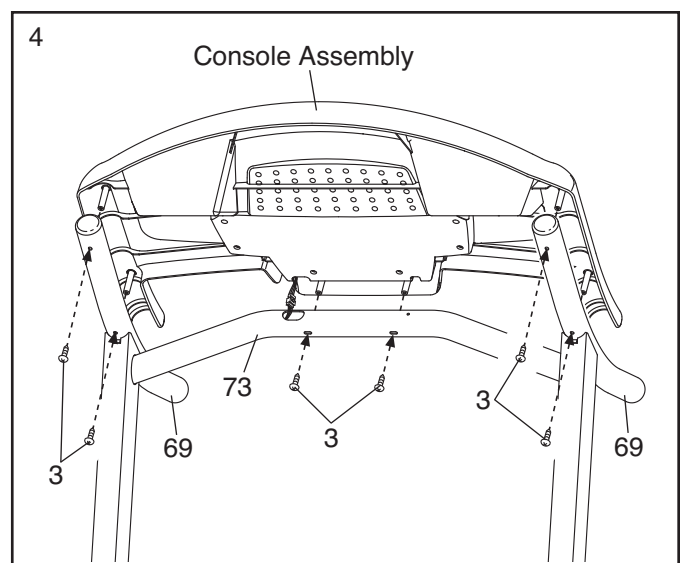

- Attach the Latch Housing (72) to the Left Upright (73) with two #10 x 1" Tek Screws (83); **start both Screws, and then tighten each of them.**

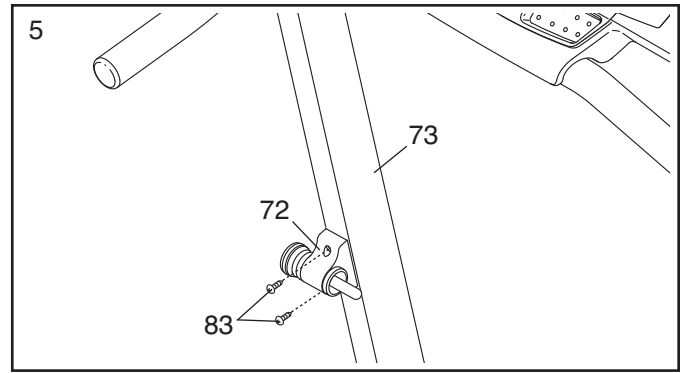

- Identify the rod end of the Gas Spring (85). **See the two small inset drawings.** Locate the Spring Clip (86) in the rod end of the Gas Spring. Using your fingernail or a screwdriver, press on the end of the Spring Clip to loosen it. Rotate the Spring Clip, and then pull the Spring Clip out of the Gas Spring. **Avoid losing the Spring Clip.** Extra Spring Clips are included.

Next, press the rod end of the Gas Spring (85) as far as possible onto the Mount (92) on the bracket in the center of the Frame (50).

See drawing 6a. Insert the Spring Clip (86) into the two indicated small holes in the rod end of the Gas Spring (85). Then, rotate the Spring Clip until it clips onto the Gas Spring.

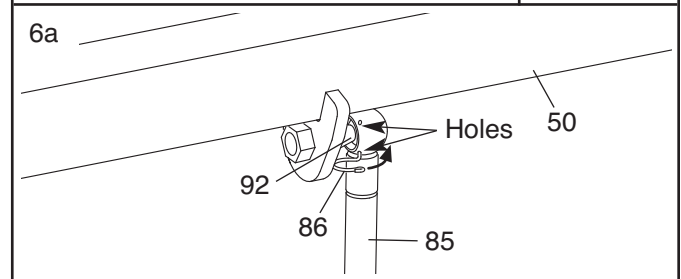
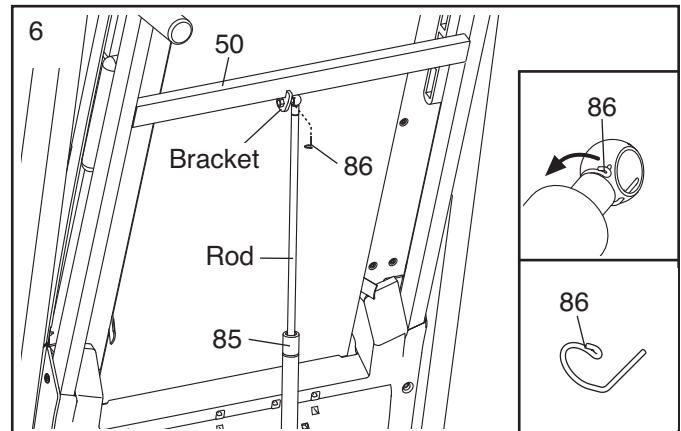

- Remove the Spring Clip (86) from the lower end of the Gas Spring (85). Press the lower end of the Gas Spring onto the Mount (92) on the bracket in the center of the Base (80). Note: It may be necessary to pivot the Frame (not shown) forward or backward slightly.

See drawing 7a. Insert the Spring Clip (86) into the two indicated small holes in the Gas Spring (85). Rotate the Spring Clip until it clips onto the Gas Spring.

Lower the treadmill. See HOW TO LOWER THE TREADMILL FOR USE on page 15.

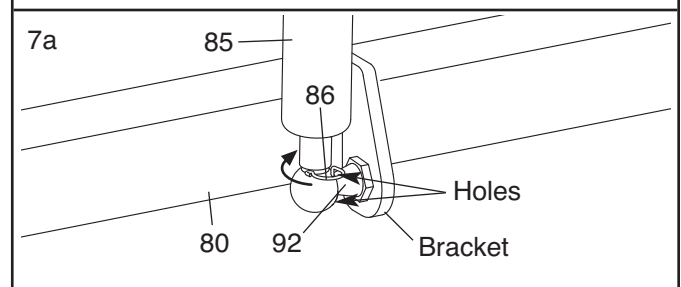
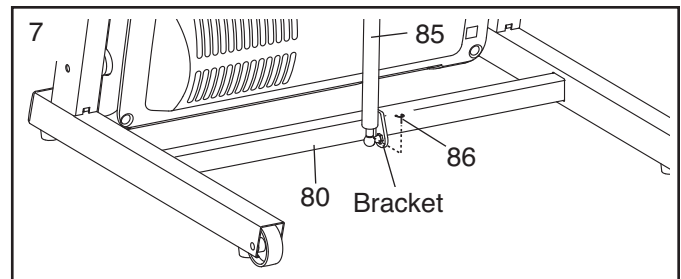

- Make sure that all parts are properly tightened before you use the treadmill.** Keep the included hex keys in a secure place. One of the hex keys is used to adjust the walking belt (see pages 17 and 18). To protect the floor or carpet, place a mat under the treadmill.

OPERATION AND ADJUSTMENT

THE PRE-LUBRICATED WALKING BELT

Your treadmill features a walking belt coated with high-performance lubricant. **IMPORTANT: Never apply silicone spray or other substances to the walking belt or the walking platform. Such substances will deteriorate the walking belt and cause excessive wear.**

HOW TO PLUG IN THE POWER CORD

This product must be earthed. If it should malfunction or break down, earthing provides a path of least resistance for electric current to reduce the risk of electric shock. This product is equipped with a power cord having an equipment-earthing conductor and an earthing plug. **IMPORTANT: If the power cord is damaged, it must be replaced with a manufacturer-recommended power cord.**

⚠ DANGER: Improper connection of the equipment-earthing conductor can result in an increased risk of electric shock. Check with a qualified electrician or serviceman if you are in doubt as to whether the product is properly earthed. Do not modify the plug provided with the product—if it will not fit the outlet, have a proper outlet installed by a qualified electrician.

Follow the steps below to plug in the power cord.

1. Plug the indicated end of the power cord into the socket on the treadmill.

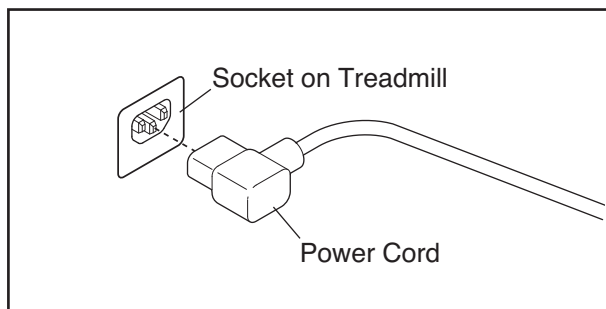

2. If you are plugging in the power cord in **Australia**, go to step 3.

If you are plugging in the power cord in the UK, first press the pins on the power cord into the metal clips in the adapter as shown. Close the adapter cover over the end of the power cord and tighten the screw in the adapter. **IMPORTANT: Make sure that the screw is tightened into the adapter cover.** Then, go to step 3.

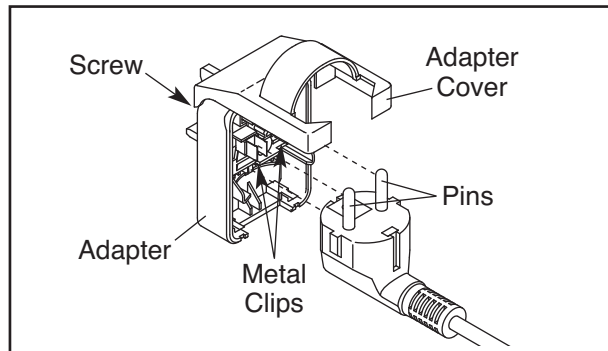

3. Plug the power cord into an appropriate outlet that is properly installed and earthed in accordance with all local codes and ordinances.

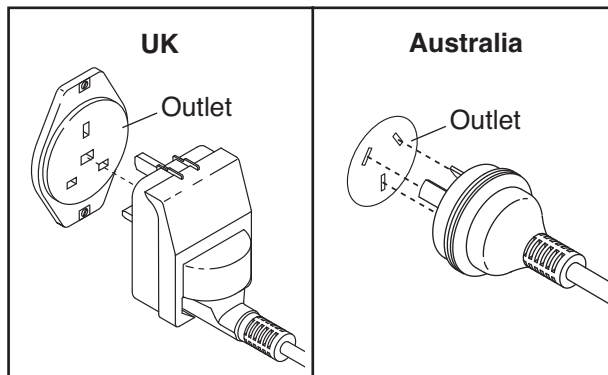

CONSOLE DIAGRAM

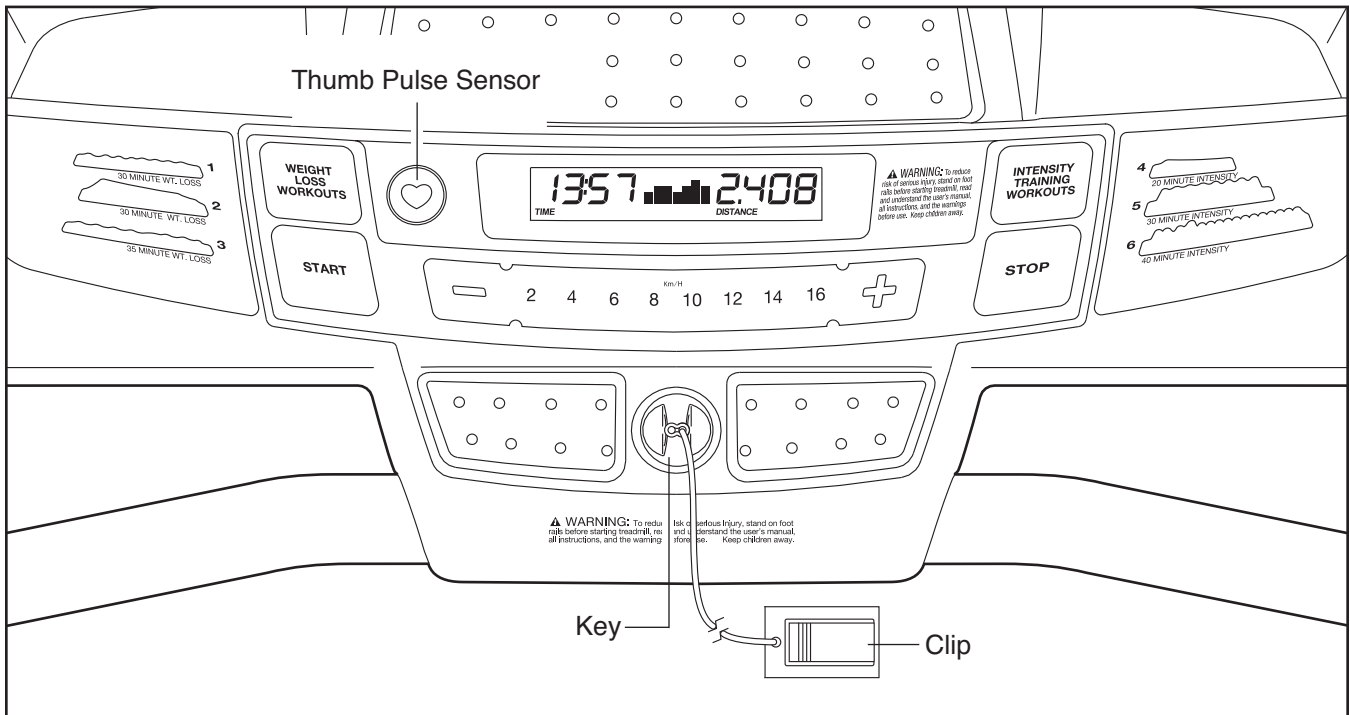

FEATURES OF THE CONSOLE

The treadmill console offers a selection of features designed to make your workouts more effective. When you select the manual mode of the console, you can change the speed of the treadmill with the touch of a button. As you exercise, the displays will provide continuous exercise feedback. You can even measure your heart rate using the built-in pulse sensor.

The console also offers six preset workouts. Each workout automatically controls the speed of the treadmill as it guides you through an effective exercise session.

To turn on the power, see page 11. **To use the manual mode,** see page 11. **To use a preset workout,** see page 13. **To use the information mode,** see page 14.

IMPORTANT: If there is a sheet of plastic on the face of the console, remove the plastic. To prevent damage to the walking platform, wear clean athletic shoes while using the treadmill. The first time the treadmill is used, observe the alignment of the walking belt, and center the walking belt if necessary (see page 18).

Note: The console can display speed and distance in either kilometers or miles. To find which unit of measurement is selected, see THE INFORMATION MODE on page 14. **For simplicity, all instructions in this manual refer to kilometers.**

HOW TO TURN ON THE POWER

IMPORTANT: If the treadmill has been exposed to cold temperatures, allow it to warm to room temperature before turning on the power. If you do not do this, you may damage the console displays or other electrical components.

Plug in the power cord (see page 9). Next, locate the power switch on the treadmill frame near the power cord. Make sure that the switch is in the reset position.

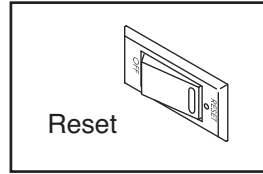

IMPORTANT: The console features a display demo mode, designed to be used if the treadmill is displayed in a store. If the displays light as soon as you plug in the power cord and press the power switch into the reset position, the demo mode is turned on. To turn off the demo mode, hold down the Stop button for a few seconds. If the displays remain lit, see THE INFORMATION MODE on page 14 to turn off the demo mode.

Next, stand on the foot rails of the treadmill. Find the clip attached to the key (see the drawing on page 10), and slide the clip onto the waistband of your clothes. Then, insert the key into the console. After a moment, the displays will light. **IMPORTANT:** In an emergency, the key can be pulled from the console, causing the walking belt to slow to a stop. Test the clip by carefully taking a few steps backward; if the key is not pulled from the console, adjust the position of the clip.

HOW TO USE THE MANUAL MODE

1. Insert the key into the console.

See HOW TO TURN ON THE POWER at the left.

2. Select the manual mode.

When the key is inserted, the manual mode will be selected. If you have selected a preset workout, remove the key and then reinsert it.



3. Start the walking belt.

To start the walking belt, press the Start button, the speed increase button, or one of the numbered speed buttons.

If you press the Start button or the speed increase button, the walking belt will begin to move at 2 Km/H. As you exercise, change the speed of the walking belt as desired by pressing the speed increase and decrease buttons. Each time you press one of the buttons, the speed setting will change by 0.1 Km/H; if you hold down the button, the speed setting will change in increments of 0.5 Km/H. Note: After you press the buttons, it may take a moment for the walking belt to reach the selected speed setting.

If you press one of the numbered speed buttons, the walking belt will gradually change speed until it reaches the selected speed setting.

To stop the walking belt, press the Stop button. The time will begin to flash in the left display. To restart the walking belt, press the Start button or the speed increase button.

4. Follow your progress with the displays.

The track—The track represents a distance of 1/4 mile (402 meters). As you walk or run on the treadmill, the indicators around the track will appear in succession until the entire track appears. The track will then disappear and the indicators will again begin to appear in succession.

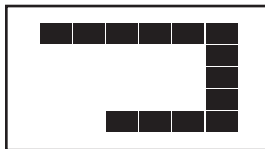

The left display—As you exercise, the left display can show the elapsed time and the approximate number of calories that you have burned. The display also shows your heart rate when you use the pulse sensor (see step 5 on this page). Note: When you use a preset workout, the left display will show the time remaining in the workout instead of the elapsed time.



The right display—The right display can show the speed of the walking belt and the distance that you have walked or run.



To reset the displays, press the Stop button, remove the key, and then reinsert the key.

5. Measure your heart rate if desired.

To measure your heart rate, **stand on the foot rails** and place your thumb on the pulse sensor (see the drawing on page 10). **Do not press too hard, or the circulation in your thumb will be restricted and your pulse may not be detected.** When your pulse is detected, the small heart symbol in the left display will flash and your heart rate will be shown. **For the most accurate heart rate reading, hold your thumb on the pulse sensor for at least 15 seconds.**

If the displayed heart rate appears to be too high or too low, or if your heart rate is not displayed, lift your thumb for a few seconds, and then reposition your thumb on the pulse sensor. Remember to stand still while measuring your heart rate.

6. When you are finished exercising, remove the key from the console.

Step onto the foot rails, press the Stop button, remove the key from the console, and put it in a secure place. When you are finished using the treadmill, press the power switch into the off position and unplug the power cord. **IMPORTANT: If you do not do this, the treadmill's electrical components may wear prematurely.**

HOW TO USE A PRESET WORKOUT

1. Insert the key into the console.

See HOW TO TURN ON THE POWER on page 11.

2. Select one of the six preset workouts.

To select a preset workout, press the Weight Loss Workouts button or the Intensity Training Workouts button repeatedly until the number of the desired workout appears in the display. The maximum speed setting of the selected workout will flash in the right display for a few seconds and then the duration of the workout will appear. In addition, a profile of the speed settings of the workout will scroll across the display.

3. Start the walking belt.

Press the Start button or the speed increase button to start the workout. A moment after you press the button, the treadmill will automatically adjust to the first speed setting of the workout. Hold the handrails and begin walking.

Each workout is divided into one-minute segments. One speed setting is programmed for each segment. Note: The same speed setting may be programmed for consecutive segments.

During the workout, the profile will show your progress. The flashing segment of the profile represents the current segment of the workout. The height of the flashing segment indicates the speed setting for the current segment. At the end of each segment, a series of tones will sound

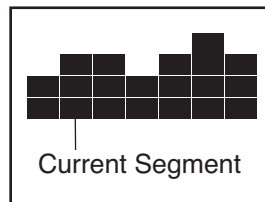

and the next segment of the profile will begin to flash. If a different speed setting is programmed for the next segment of the workout, the new speed setting will flash in the display to alert you. The treadmill will then automatically adjust to the speed setting for the next segment.

The workout will continue in this way until the last segment of the profile flashes in the display and the last segment ends. The walking belt will then slow to a stop.

If the speed setting for the current segment is too high or too low, you can manually override the setting by pressing the speed buttons; **however, when the current segment of the workout ends, the treadmill will automatically adjust to the speed setting for the next segment.**

To stop the workout at any time, press the Stop button. To restart the workout, press the Start button or the speed increase button. The walking belt will begin to move at 2 Km/H. When the next segment of the workout begins, the treadmill will automatically adjust to the speed setting for that segment.

4. Follow your progress with the displays.

See step 4 on page 12.

5. Measure your heart rate if desired.

See step 5 on page 12.

6. When you are finished exercising, remove the key from the console.

See step 6 on page 12.

THE INFORMATION MODE

The console features an information mode that allows you to turn on and turn off the demo mode and to select miles or kilometers as the unit of measurement. The information mode also keeps track of treadmill usage information.

To select the information mode, hold down the Stop button, insert the key into the console, and then release the Stop button. When the information mode is selected, the following information will appear in the display:

The console features a display demo mode, designed to be used if the treadmill is displayed in a store. While the demo mode is turned on, the console will function normally when you plug in the power cord, press the power switch into the reset position, and insert the key into the console. However, when you remove the key, the displays will remain lit, although the buttons will not function. If the demo mode is turned on, a “d” will appear in the left display while the information mode is selected. To turn on or turn off the demo mode, press the speed decrease button.



The left display will also show an “M” for metric kilometers or an “E” for English miles. To change the unit of measurement, press the speed increase button.

The right display will show the total number of hours that the treadmill has been operated and the total number of miles or kilometers that the walking belt has moved, for a few seconds each.



To exit the information mode, remove the key from the console.

HOW TO CHANGE THE INCLINE OF THE TREADMILL

To vary the intensity of your exercise, you can change the incline of the treadmill. There are two incline levels. **Before changing the incline, remove the key and unplug the power cord.** Next, fold the treadmill to the storage position (see page 15).

To change the incline, rotate both incline feet to the desired position. **CAUTION: Before using the treadmill, make sure that both incline feet are in the same position and are held firmly in place.**

After you have adjusted the incline feet, lower the treadmill (see page 15).

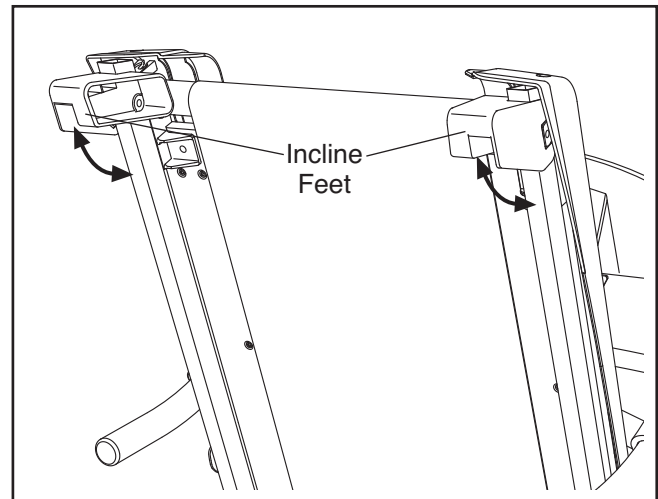

HOW TO FOLD AND MOVE THE TREADMILL

HOW TO FOLD THE TREADMILL

Before folding the treadmill, remove the key and unplug the power cord. **CAUTION: You must be able to safely lift 45 lbs. (20 kg) to raise, lower, or move the treadmill.**

1. Hold the metal frame firmly in the location shown by the arrow below. **CAUTION: Do not hold the frame by the plastic foot rails. Bend your legs and keep your back straight.** Raise the frame about halfway to the vertical position.

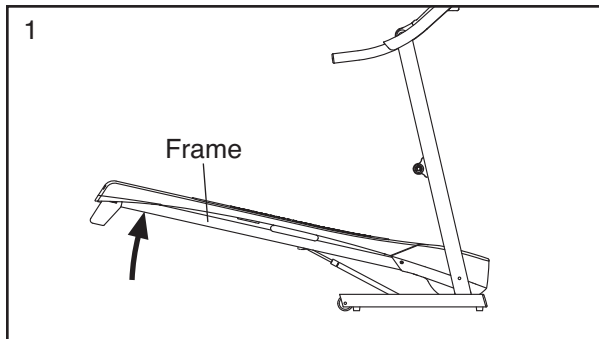

2. Hold the treadmill firmly with your right hand as shown. Pull the latch knob to the left and hold it. Raise the frame until the catch is past the latch pin. Then, slowly release the latch knob; **make sure that the catch is resting against the latch pin.**

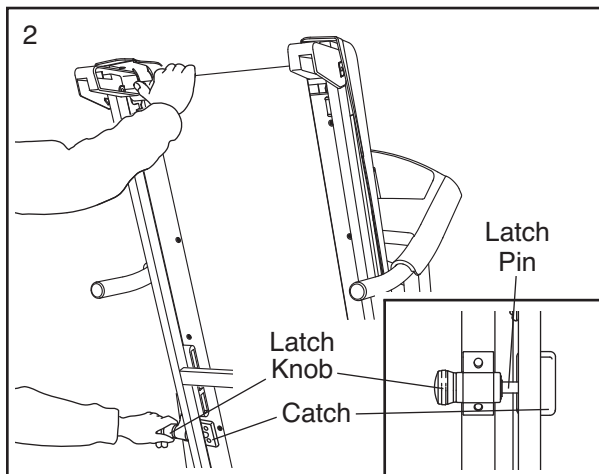

To protect the floor or carpet, place a mat under the treadmill. Keep the treadmill out of direct sunlight. Do not leave the treadmill in the storage position in temperatures above 85° F (30° C).

HOW TO MOVE THE TREADMILL

Before moving the treadmill, fold it as described at the left. **CAUTION: Make sure that the catch is resting against the latch pin. Moving the treadmill may require two people.**

1. Hold the frame and one of the handrails, and place one foot against a wheel.

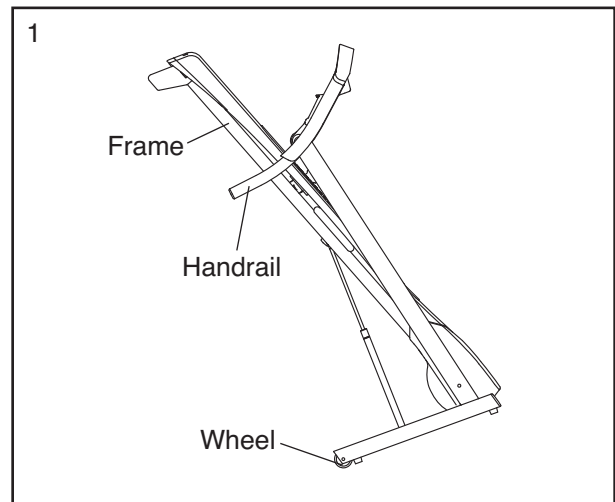

2. Pull back on the handrail until the treadmill will roll on the wheels, and carefully move it to the desired location. **CAUTION: Do not move the treadmill without tipping it back, do not pull on the frame, and do not move the treadmill over an uneven surface.**
3. Place one foot against a wheel, and carefully lower the treadmill.

HOW TO LOWER THE TREADMILL FOR USE

1. **See drawing 2.** Hold the upper end of the treadmill with your right hand as shown. Pull the latch knob to the left and hold it. Next, lower the frame until it is past the latch pin. Then, release the latch knob.
2. **See drawing 1 at the left.** Hold the metal frame firmly with both hands, and lower it to the floor. **CAUTION: Do not hold the frame by the plastic foot rails, and do not drop the frame. Bend your legs and keep your back straight.**

TROUBLESHOOTING

Most treadmill problems can be solved by following the steps below. Find the symptom that applies, and follow the steps listed. If further assistance is needed, please see the front cover of this manual.

PROBLEM: The power does not turn on

SOLUTION: a. Make sure that the power cord is plugged into a properly earthed outlet (see page 9). If an extension cord is needed, use only a 3-conductor, 14-gauge (1 mm²) cord that is no longer than 5 ft. (1.5 m).

b. After the power cord has been plugged in, make sure that the key is inserted into the console.

c. Check the power switch located on the treadmill frame near the power cord. If the switch protrudes as shown, the switch has tripped. To reset the switch, wait for five minutes and then press the switch back in.

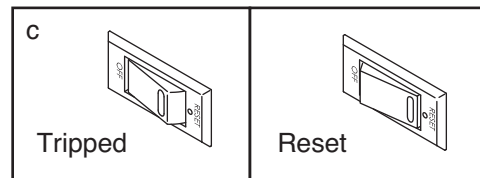

PROBLEM: The power turns off during use

SOLUTION: a. Check the power switch (see the drawing above). If the switch has tripped, wait for five minutes and then press the switch back in.

b. Make sure that the power cord is plugged in.

c. Remove the key from the console. Reinsert the key into the console.

d. If the treadmill still will not run, please see the front cover of this manual.

PROBLEM: The console displays remain lit when you remove the key from the console

SOLUTION: a. The console features a display demo mode, designed to be used if the treadmill is displayed in a store. If the displays remain lit when you remove the key, the demo mode is turned on. To turn off the demo mode, hold down the Stop button for a few seconds. If the displays are still lit, see THE INFORMATION MODE on page 14 to turn off the demo mode.

PROBLEM: The displays of the console do not function properly

SOLUTION: a. Remove the key from the console and **UNPLUG THE POWER CORD**. Place the treadmill in the storage position (see HOW TO FOLD THE TREADMILL on page 15).

Remove the six indicated M4.2 x 13mm Washer Head Screws (5) and the six Foot Rail Flat Washers (25). Next, lower the Frame (50) (see HOW TO LOWER THE TREADMILL FOR USE on page 15).

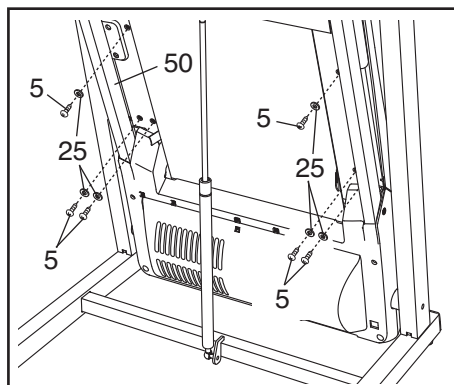

Remove the five indicated M4.2 x 19mm Washer Head Screws (9). Then, carefully remove the Motor Hood (56).

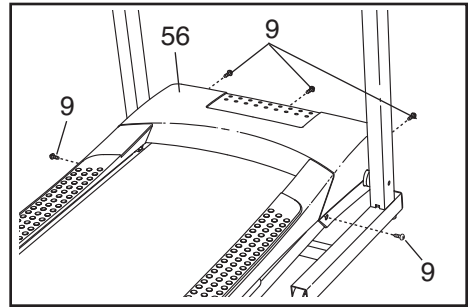

Locate the Reed Switch (42) and the Magnet (44) on the left side of the Pulley (46). Turn the Pulley until the Magnet is aligned with the Reed Switch. **Make sure that the gap between the Magnet and the Reed Switch is about 1/8 in. (3 mm).** If necessary, loosen the M4.2 x 13mm Tek Screw (7), move the Reed Switch slightly, and then retighten the Screw. Reattach the Motor Hood (not shown), and run the treadmill for a few minutes to check for a correct speed reading.

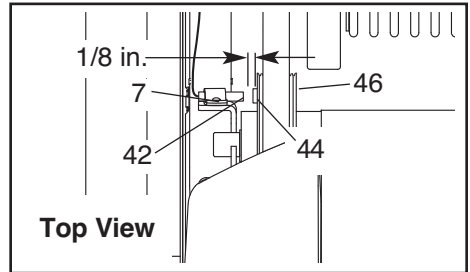

PROBLEM: The walking belt slows when walked on

SOLUTION: a. If an extension cord is needed, use only a 3-conductor, 14-gauge (1 mm²) cord that is no longer than 5 ft. (1.5 m).

b. If the walking belt is overtightened, treadmill performance may decrease and the walking belt may become damaged. Remove the key and **UNPLUG THE POWER CORD**. Using the hex key, turn both idler roller bolts counterclockwise, 1/4 of a turn. When the walking belt is properly tightened, you should be able to lift each edge of the walking belt 2 to 3 in. (5 to 7 cm) off the walking platform. Be careful to keep the walking belt centered. Then, plug in the power cord, insert the key, and run the treadmill for a few minutes. Repeat until the walking belt is properly tightened.

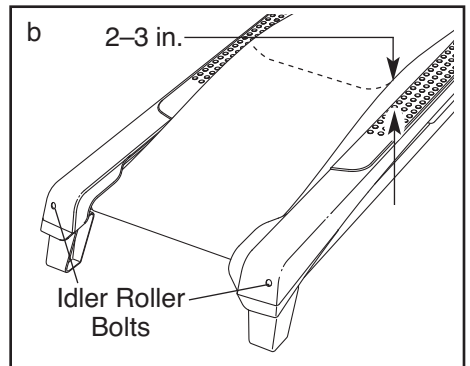

c. If the walking belt still slows when walked on, see the front cover of this manual.

PROBLEM: The walking belt is off-center or slips when walked on

SOLUTION: a. **If the walking belt has shifted to the left**, first remove the key and **UNPLUG THE POWER CORD**. Using the hex key, turn the left idler roller bolt clockwise 1/2 of a turn. Be careful not to overtighten the walking belt. **If the walking belt has shifted to the right**, turn the left idler roller bolt counterclockwise 1/2 of a turn. Then, plug in the power cord, insert the key, and run the treadmill for a few minutes. Repeat until the walking belt is centered.

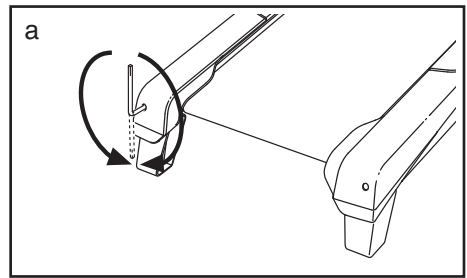

b. **If the walking belt slips when walked on**, first remove the key and **UNPLUG THE POWER CORD**. Using the hex key, turn both idler roller bolts clockwise, 1/4 of a turn. When the walking belt is correctly tightened, you should be able to lift each edge of the walking belt 2 to 3 in. (5 to 7 cm) off the walking platform. Be careful to keep the walking belt centered. Then, plug in the power cord, insert the key, and carefully walk on the treadmill for a few minutes. Repeat until the walking belt is properly tightened.

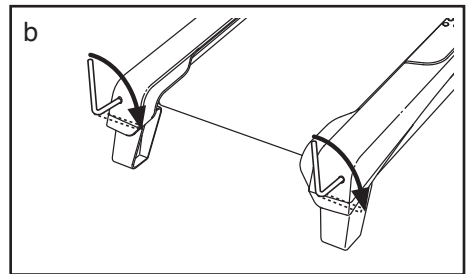

EXERCISE GUIDELINES

⚠ WARNING: Before beginning any exercise program, consult your physician. This is especially important for persons over age 35 or persons with pre-existing health problems.

The pulse sensor is not a medical device. Various factors may affect the accuracy of heart rate readings. The pulse sensor is intended only as an exercise aid in determining heart rate trends in general.

These guidelines will help you to plan your exercise program. For detailed exercise information, obtain a reputable book or consult your physician. Remember, proper nutrition and adequate rest are essential for successful results.

EXERCISE INTENSITY

Whether your goal is to burn fat or to strengthen your cardiovascular system, exercising at the proper intensity is the key to achieving results. You can use your heart rate as a guide to find the proper intensity level. The chart below shows recommended heart rates for fat burning and aerobic exercise.

165	155	145	140	130	125	115	♥
145	138	130	125	118	110	103	♥
125	120	115	110	105	95	90	♥
<hr/>							
20	30	40	50	60	70	80	

To find the proper intensity level, find your age at the bottom of the chart (ages are rounded off to the nearest ten years). The three numbers listed above your age define your “training zone.” The lowest number is the heart rate for fat burning, the middle number is the heart rate for maximum fat burning, and the highest number is the heart rate for aerobic exercise.

Burning Fat—To burn fat effectively, you must exercise at a low intensity level for a sustained period of time. During the first few minutes of exercise, your body uses *carbohydrate calories* for energy. Only after the first few minutes of exercise does your body begin to use stored *fat calories* for energy. If your goal is to burn fat, adjust the intensity of your exercise until your heart rate is near the lowest number in your training zone. For maximum fat burning, exercise with your heart rate near the middle number in your training zone.

Aerobic Exercise—If your goal is to strengthen your cardiovascular system, you must perform aerobic exercise, which is activity that requires large amounts of oxygen for prolonged periods of time. For aerobic exercise, adjust the intensity of your exercise until your heart rate is near the highest number in your training zone.

WORKOUT GUIDELINES

Warming Up—Start with 5 to 10 minutes of stretching and light exercise. A warm-up increases your body temperature, heart rate, and circulation in preparation for exercise.

Training Zone Exercise—Exercise for 20 to 30 minutes with your heart rate in your training zone. (During the first few weeks of your exercise program, do not keep your heart rate in your training zone for longer than 20 minutes.) Breathe regularly and deeply as you exercise—never hold your breath.

Cooling Down—Finish with 5 to 10 minutes of stretching. Stretching increases the flexibility of your muscles and helps to prevent post-exercise problems.

EXERCISE FREQUENCY

To maintain or improve your condition, complete three workouts each week, with at least one day of rest between workouts. After a few months of regular exercise, you may complete up to five workouts each week, if desired. Remember, the key to success is to make exercise a regular and enjoyable part of your everyday life.

PART LIST—Model No. WETL39710.0

R0610A

To locate the parts listed below, see the EXPLODED DRAWING near the end of this manual.

Key No.	Qty.	Description	Key No.	Qty.	Description
1	4	M10 x 65mm Bolt	48	1	Walking Platform
2	4	M10 x 45mm Bolt	49	1	Right Foot Rail
3	17	M4.2 x 19mm Screw	50	1	Frame
4	2	M8 x 35mm Bolt	51	1	Right Idler Roller Bracket
5	18	M4.2 x 13mm Washer Head Screw	52	1	Right Incline Foot
6	6	M4.2 x 13mm Screw	53	1	Left Incline Foot
7	1	M4.2 x 13mm Tek Screw	54	1	Idler Roller
8	4	M4.2 x 19mm Tek Screw	55	1	Left Idler Roller Bracket
9	5	M4.2 x 19mm Washer Head Screw	56	1	Motor Hood
10	1	M4.2 x 13mm Bright Screw	57	1	Drive Motor Bracket
11	8	M4 x 10mm Screw	58	1	Drive Motor
12	4	M8 x 30mm Bolt	59	1	Electronics Bracket
13	4	M4.2 x 13mm Indented Screw	60	1	Controller
14	2	M6 x 70mm Bolt	61	1	Belly Pan
15	2	1/4" Motor Bolt	62	1	Power Switch
16	1	M8 x 102mm Bolt	63	1	Grommet
17	2	M8 x 20mm Bolt	64	1	Power Cord
18	2	3/8" x 2" Bolt	65	4	8" Tie
19	2	M8 x 40mm Bolt	66	1	Releasable Wire Tie
20	2	M10 x 110mm Bolt	67	1	Console Base
21	4	M6 Star Washer	68	4	Handrail Cap
22	2	M8.4 Star Washer	69	2	Handrail
23	4	M4.2 Star Washer	70	1	Console
24	2	Roller Spacer	71	1	Upright Wire
25	14	Foot Rail Flat Washer	72	1	Latch Housing
26	4	#8 Flat Washer	73	1	Upright
27	2	M10 Star Washer	74	1	Key/Clip
28	2	M10 Flat Washer	75	3	Wire Tie
29	6	M8 Flange Nut	76	2	Frame Spacer
30	2	M10 U-nut	77	2	Base Cap
31	1	M8 Nut	78	4	Base Pad
32	2	3/8" Locknut	79	2	Wheel
33	3	#8 Hood Clip	80	1	Base
34	2	M8 Rear Foot Nut	81	1	Upright Grommet
35	1	6 mm Hex Key	82	2	1/4" Flat Washer
36	1	4 mm Hex Key	83	2	#10 x 1" Tek Screw
37	1	Left Foot Rail	84	1	Latch Pin Assembly
38	1	Latch Warning Decal	85	1	Gas Spring
39	1	Catch	86	2	Spring Clip
40	2	Platform Cushion	87	1	Filter
41	2	Belt Guide	88	1	Receptacle
42	1	Reed Switch	89	1	Power Cord Adapter
43	1	Reed Switch Clamp	90	1	Transformer
44	1	Magnet	91	2	5/16" Nut
45	1	Drive Belt	92	2	Mount
46	1	Drive Roller/Pulley	*	—	User's Manual
47	1	Walking Belt			

Note: Specifications are subject to change without notice. For information about ordering replacement parts, see the back cover of this manual. *These parts are not illustrated.

EXPLODED DRAWING A—Model No. WETL39710.0

R0610A

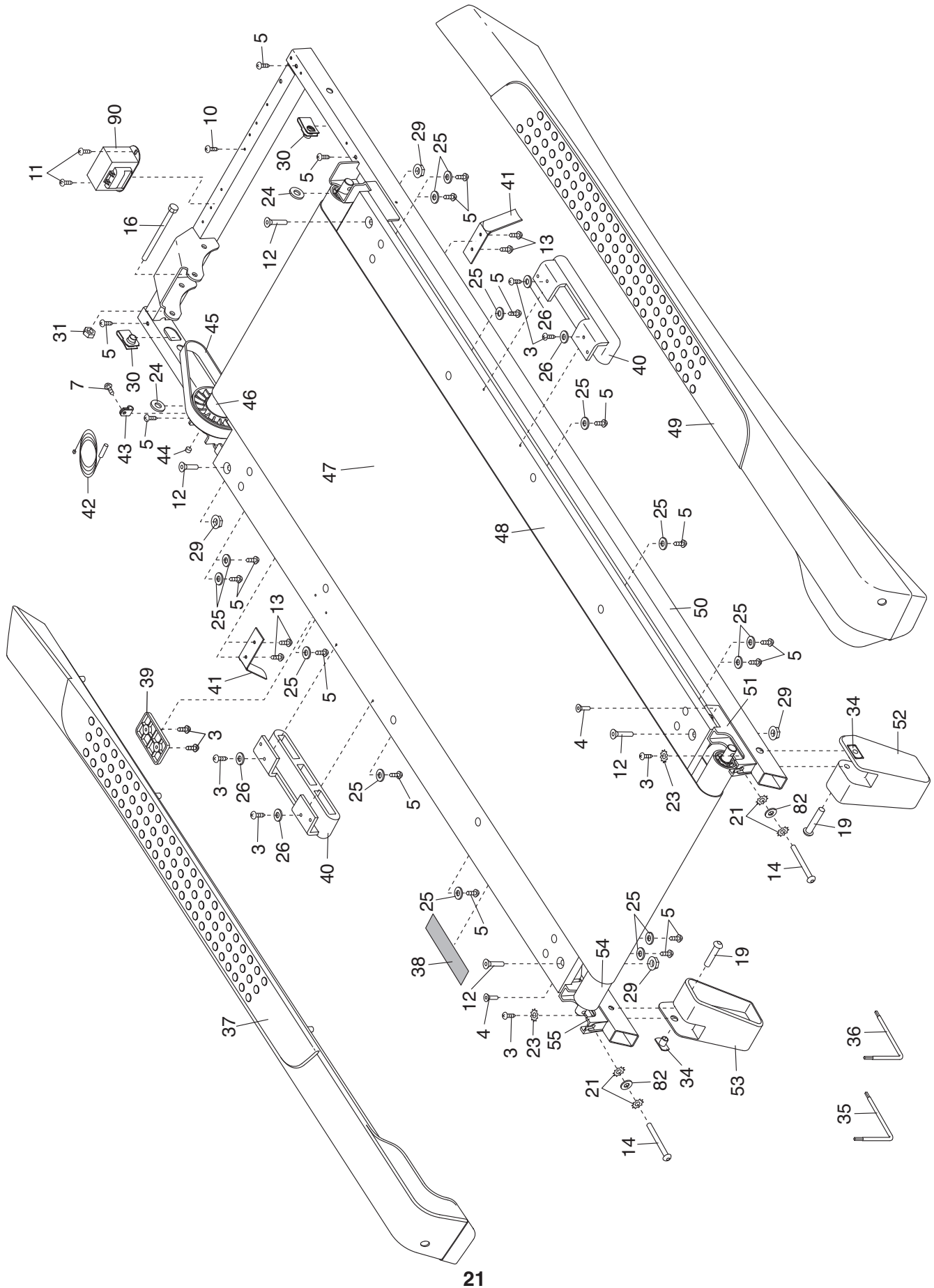

EXPLODED DRAWING B—Model No. WETL39710.0

R0610A

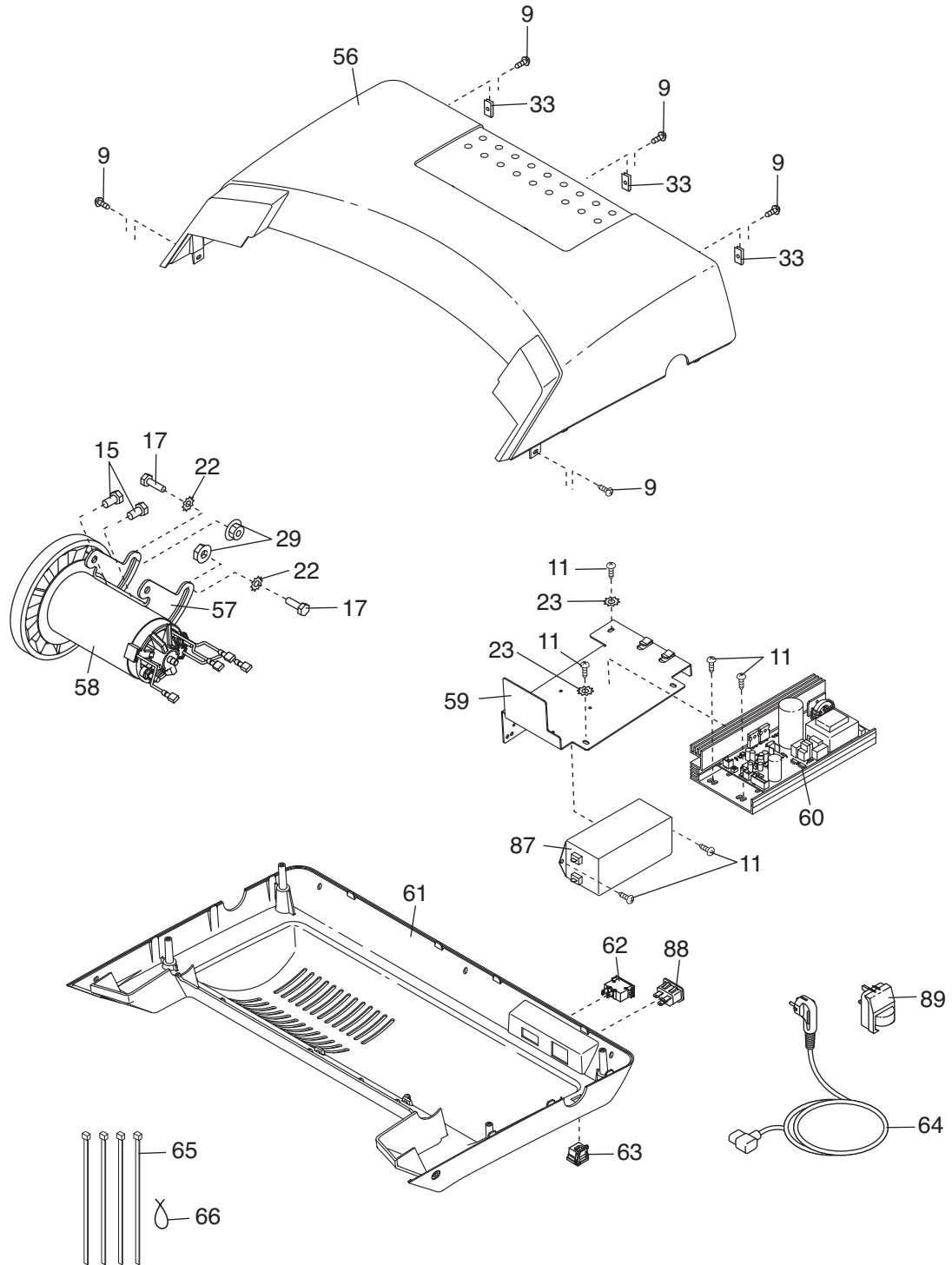

EXPLODED DRAWING C—Model No. WETL39710.0

R0610A

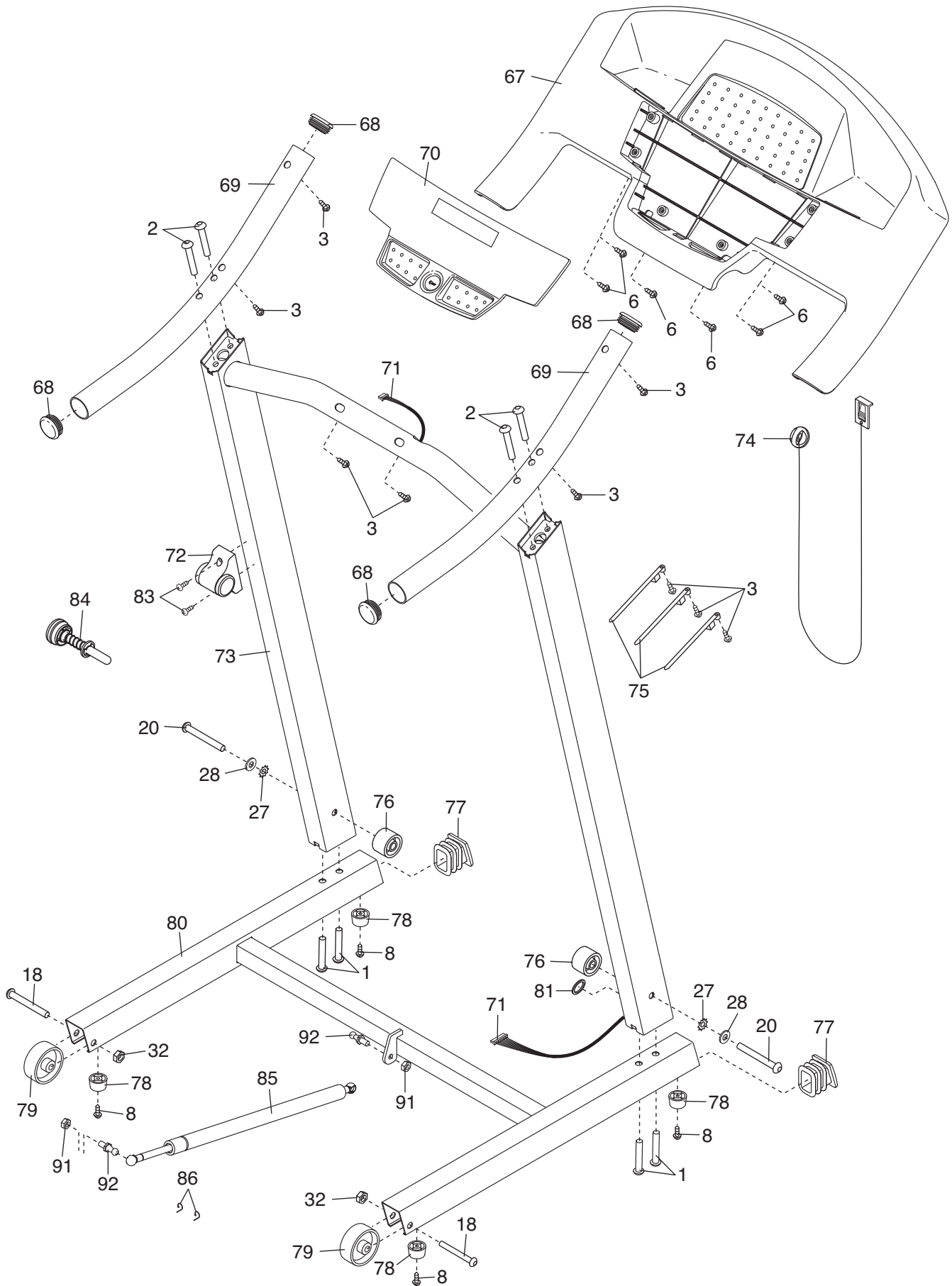

ORDERING REPLACEMENT PARTS

To order replacement parts, see the front cover of this manual. To help us assist you, please be prepared to provide the following information when contacting us:

- the model number and the serial number of the product (see the front cover of this manual)
- the name of the product (see the front cover of this manual)
- the key number and description of the replacement part(s) (see the PART LIST and the EXPLODED DRAWING near the end of this manual)

RECYCLING INFORMATION

This electronic product must not be disposed of in municipal waste. To preserve the environment, this product must be recycled after its useful life as required by law.

Please use recycling facilities that are authorized to collect this type of waste in your area. In doing so, you will help to conserve natural resources and improve European standards of environmental protection. If you require more information about safe and correct disposal methods, please contact your local city office or the establishment where you purchased this product.

