



North America Limited

# PRACTICAL USER'S GUIDE FOR THE ELECTRIC PATIO STOVE

**MODEL NUMBER:**

**EOS-2006**

Serial Number \_\_\_\_\_

Model Number \_\_\_\_\_

CAT Number \_\_\_\_\_

Quality checked by:

*Valued Customer,*

*We are pleased that you have chosen to purchase an electric stove product manufactured by Dimplex North America.*

*Over the years, valuable memories will occur around the warmth and comfort of your hearth. Thank you for allowing our product to be the backdrop for those special moments.*

7207940100REV01

## QUICK REFERENCE GUIDE

1. Prior to the first use of the Electric Patio Stove, verify that the circuit breakers for the unit are on.
  2. The information regarding the model of your Electric Patio Stove can be found on the rating plate located in the upper left inside of the unit. Refer to Figure 1.
  3. If you have any technical questions or concerns regarding the operation of your Electric Patio Stove, or require service contact Dimplex North America customer service at 1-888-DIMPLEX (1-888-346-7539) before returning the product to the point of purchase.
- 

## CONTENTS

<b>PAGE 1</b>	Important Instructions
<b>PAGE 2</b>	Model and Serial Number Information
<b>PAGE 3</b>	Electric Patio Stove Installation
<b>PAGE 4</b>	Operation
<b>PAGE 5</b>	Maintenance
<b>PAGE 6</b>	Warranty

## **IMPORTANT INSTRUCTIONS**

### **PLEASE RETAIN THIS USER'S GUIDE FOR FUTURE REFERENCE**

When using electrical appliances, basic precautions should always be followed to reduce the risk of fire, electric shock, and injury to persons, including the following:

1. Read all instructions before using the Electric Patio Stove.
2. Always unplug the Electric Patio Stove when not in use.
3. Do not operate any unit with a damaged cord or plug, or if the Electric Patio Stove has been dropped or damaged in any manner. Return unit to authorized service facility for examination, electrical or mechanical adjustment, or repair.

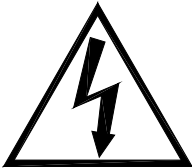

**CAUTION**  
**RISK OF ELECTRIC SHOCK**  
**DO NOT OPEN**  
**NO USER-SERVICEABLE PARTS INSIDE**



4. Do not modify the Electric Patio Stove. Use it only as described in this manual. Any other use is not recommended by the manufacturer and may cause fire, electric shock or injury to persons.
5. To reduce the risk of electric shock, this appliance has a polarized plug (one blade is wider than the other). This plug will fit in a polarized outlet only one way. If the plug does not fit fully in the outlet, reverse the plug. If it still does not fit, contact a qualified electrician to install the proper outlet. Do not change the plug in any way.
6. This unit must be plugged into a GFI receptacle.
7. Do not burn wood or other materials in the Electric Patio Stove.
8. Always use a certified electrician should new circuits or outlets be required.
9. Always use properly grounded, fused and polarized outlets.
10. Disconnect all power supply before performing any cleaning, maintenance or relocation of the unit.
11. When transporting or storing the unit and cord, keep in a dry place, free from excessive vibration and store so as to avoid damage.

**SAVE THESE INSTRUCTIONS**

**NOTE:** Procedures and techniques that are considered important enough to emphasize.

**CAUTION:** Procedures and techniques which, if not carefully followed, will result in damage to the equipment.

**WARNING:** Procedures and techniques which, if not carefully followed, will expose the user to the risk of fire, serious injury, illness or death.

## MODEL AND SERIAL NUMBER INFORMATION

If you have any questions about our products please have the catalogue/model and serial numbers available upon calling customer service. To locate the catalogue/model and serial number labels see below. (FIGURE 1)

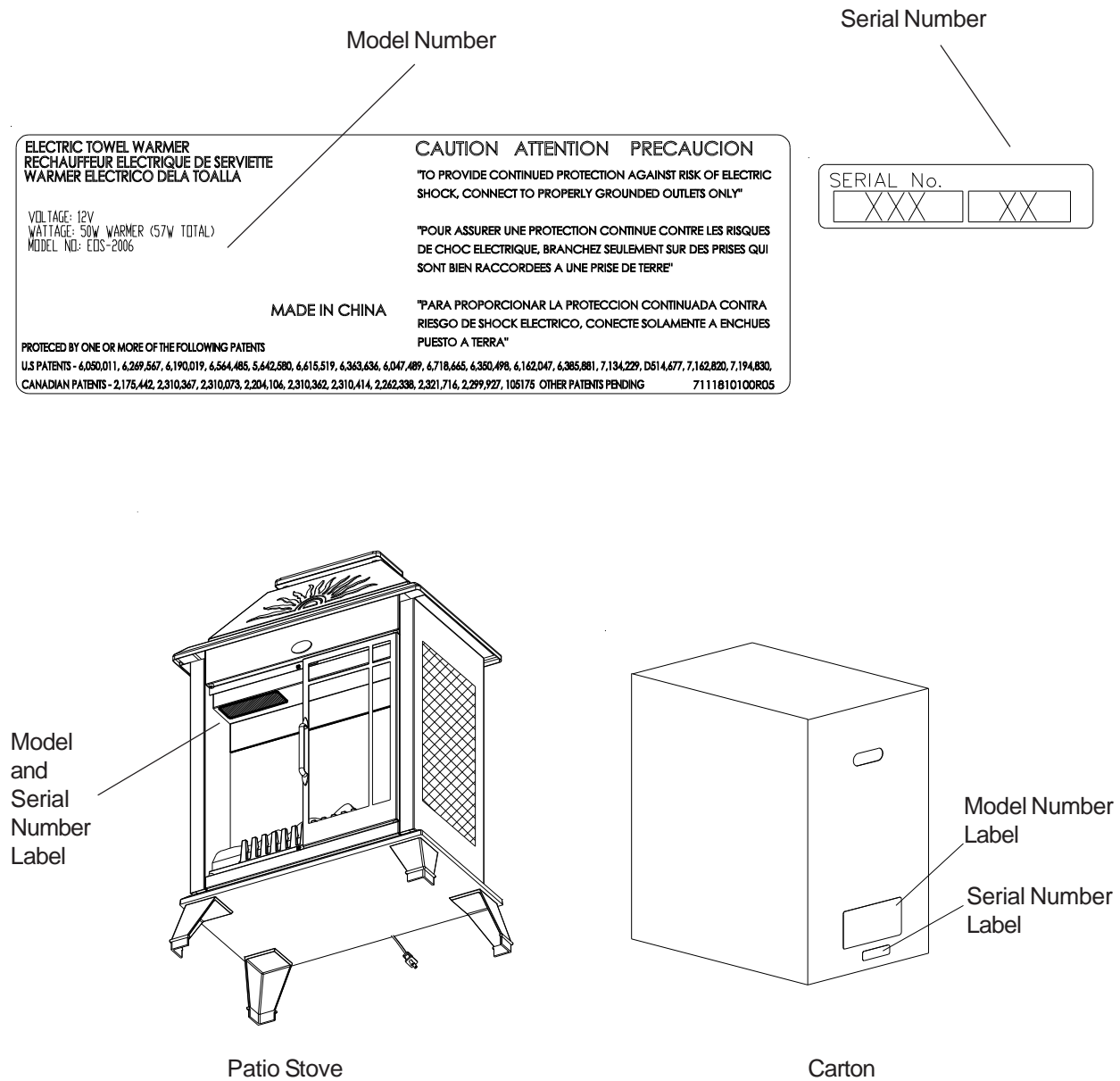

FIGURE 1

# ELECTRIC PATIO STOVE INSTALLATION

## NOTE

A 120 volt circuit is required. Additional appliances on the same circuit may exceed the current rating of the circuit breaker.

Only use the power adapter supplied by Dimplex North America for this unit as it is the proper voltage needed. If any other adapter is used, risk of damage, fire, electric shock or injury to persons may occur.

## WARNING

Ensure the power cord and power adapter are not installed so that it is pinched or against a sharp edge and ensure that the power cord and power adapter are stored or secured to avoid tripping or snagging to reduce the risk of fire, electric shock or injury to persons.

Construction and electrical outlet wiring must comply with local building codes and other applicable regulations to reduce the risk of fire, electric shock and injury to persons.

Do not attempt to wire your own new outlets or circuits. To reduce the risk of fire, electric shock or injury to persons, always use a licensed electrician.

## INSTRUCTIONS

1. Make sure the unit's MAIN ON/OFF switch is switched OFF (refer to FIGURE 2 below).
2. Select a suitable, level location away from standing water. For ease of electrical hook up, you may wish to locate the Electric Patio Stove near an existing outlet. A 15amp/120 volt outdoor GFI outlet is required.
3. Plug the supplied power adapter into the receptacle located on the bottom rear of the Electric Patio Stove. Firmly insert the end of the power supply cord into the electric patio stove receptacle and tighten the retaining nut. Insert the opposite end of the power supply cord into the receptacle on the power adapter and tighten the retaining nut.
4. Plug the power adapter into a GFI outlet rated for 15amp/120 volts. If the cord does not reach, you may use an extension cord with a minimum rating of 120 volts, 8 amps, 18 gauge and approved for outdoor use.

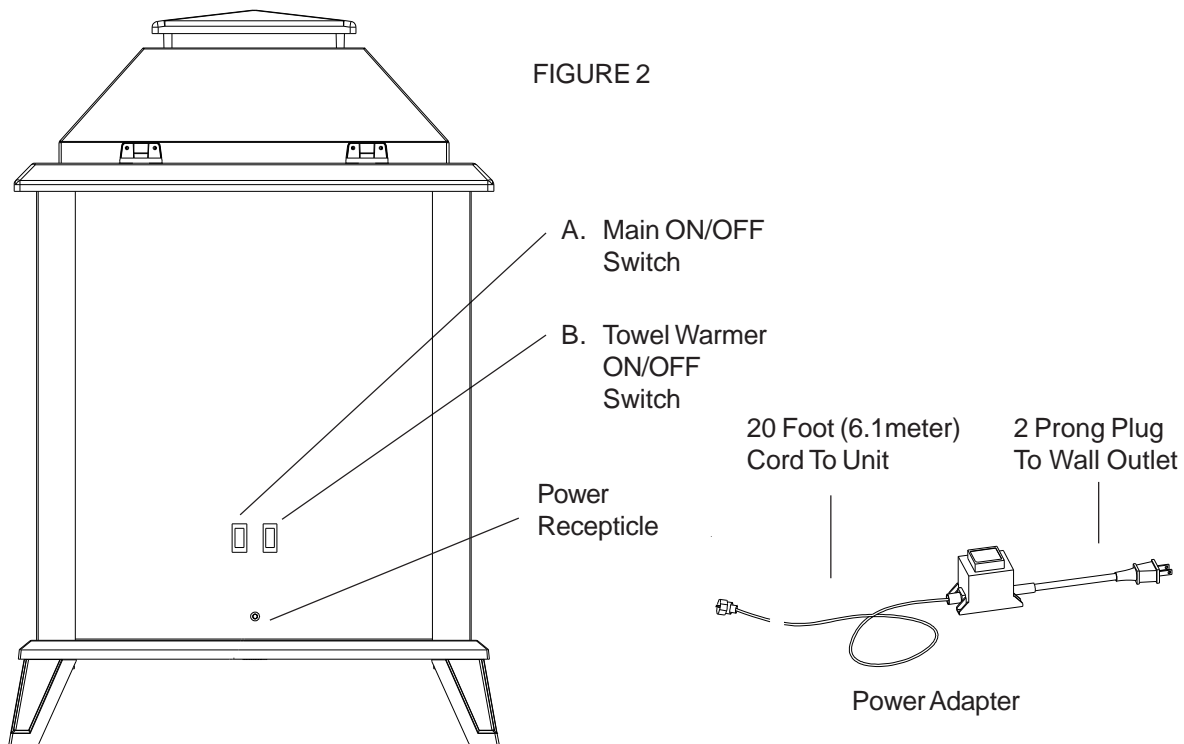

## OPERATION

To access the controls go to the back of the Electric Patio Stove (refer to FIGURE 2 on previous page).

### A. MAIN ON/OFF SWITCH

The on/off switch supplies power to all unit functions (flame/towel warmer)

### B. TOWEL WARMER ON/OFF SWITCH

The towel warmer on/off switch supplies power to the towel warmer. The main on/off switch must be on to activate towel warmer switch.

**NOTE:** When the Towel Warmer is switched ON, the warmer will operate. **The warmer will not operate if the cooler insert is still in place within the unit.**

## BEVERAGE COOLER

This Electric Patio Stove has a convenient hidden beverage cooler located under the flip top lid. To use the cooler ensure that cooler is inserted. Ice may be used. Place beverages in cooler insert and surround with ice. Refer to FIGURE 3.

FIGURE 3

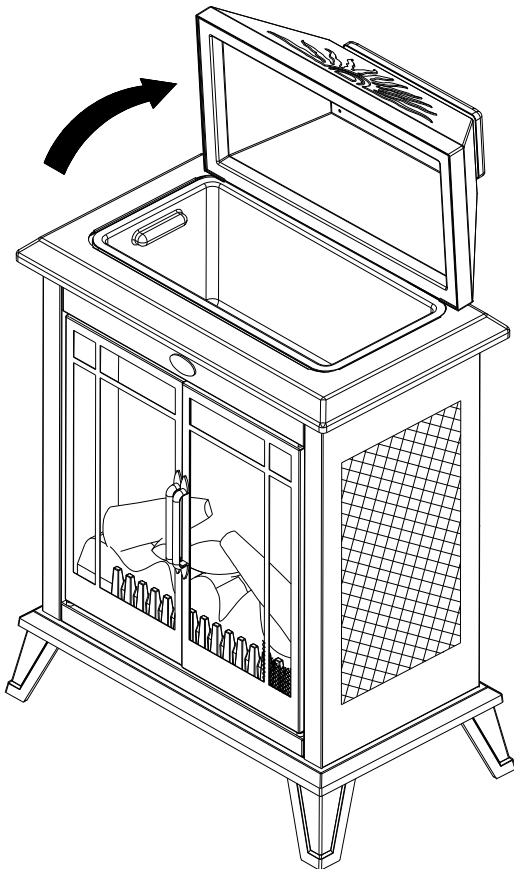
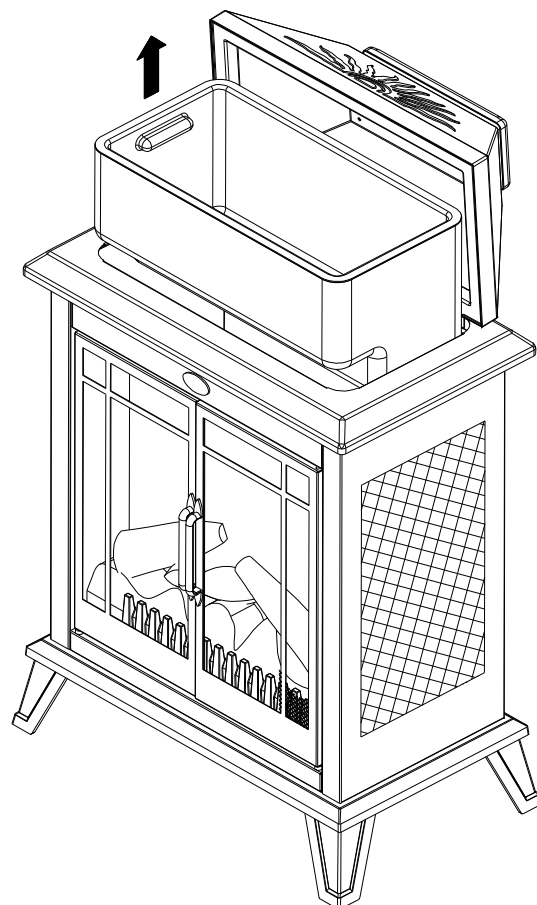

FIGURE 4



## TOWEL WARMER

This unit has a convenient towel warmer built in. To operate the towel warmer remove cooler insert (FIGURE 4), activate towel warmer switch (FIGURE 2), and place dry towels in towel warmer compartment.

**NOTE: THIS IS NOT A TOWEL DRYER, DO NOT PLACE DAMP OR WET TOWELS IN COMPARTMENT.**

## **MAINTENANCE**

### **GLASS CLEANING**

The mirror is cleaned in the factory during the assembly operation. During shipment, installation, handling, etc., the clear door may collect dust particles, these can be removed by dusting lightly with a clean dry cloth.

To remove fingerprints or other marks, the clear door can be cleaned with a damp cloth. The clear door should be completely dried with a lint free cloth to prevent water spots. To prevent scratching, do not use abrasive cleaners or spray liquids on the clear door surface.

### **STOVE SURFACE CLEANING**

Use warm water only to clean painted surfaces of the Electric Patio Stove. Do not use abrasive cleaners.

### **SERVICING**

Except for cleaning described above, an authorized service representative should perform any other servicing.

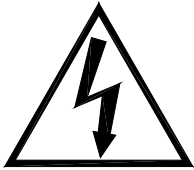

**CAUTION**  
RISK OF ELECTRIC SHOCK  
DO NOT OPEN  
NO USER-SERVICEABLE PARTS INSIDE



## ONE YEAR WARRANTY

### *Products to which this limited warranty applies*

This limited warranty applies to your newly purchased Dimplex Electric Patio Stove. This limited warranty applies only to purchases made in any province of Canada *except* for Yukon Territory, Nunavut, or Northwest Territories or in any of the 50 States of the USA (and the District of Columbia) *except* for Hawaii and Alaska. This limited warranty applies to the original purchaser of the product only and is not transferable.

### *Products excluded from this limited warranty*

Light bulbs are not covered by this limited warranty and are the sole responsibility of the owner/purchaser. Products purchased in the Yukon Territory, Nunavut, the Northwest Territories, Hawaii, or Alaska are not covered by this limited warranty. Products purchased in these states, provinces, or territories are sold AS IS without warranty or condition of any kind (including, without limitation, any implied warranties or conditions of merchantability or fitness for a particular purpose) and the entire risk of as to the quality and performance of the products is with the purchaser, and in the event of a defect the purchaser assumes the entire cost of all necessary servicing or repair.

### *What this limited warranty covers and for how long*

Products covered by this limited warranty have been tested and inspected prior to shipment and, subject to the provisions of this warranty, Dimplex warrants such products to be free from defects in material and workmanship for a period of 12 months from the date of the first purchase of such product.

The limited 12 month warranty period also applies to any implied warranties that may exist under applicable law. Some jurisdictions do not allow limitations on how long an implied warranty lasts, so the above limitation may not apply to the purchaser.

### *What this limited warranty does not cover*

This limited warranty does not apply to products that have been repaired (except by Dimplex or its authorized service representatives) or otherwise altered. This limited warranty does further not apply to defects resulting from misuse, abuse, accident, neglect, incorrect installation, improper maintenance or handling, or operation with an incorrect power source.

### *What you must do to get service under this limited warranty*

Defects must be brought to the attention of Dimplex Technical Service by contacting Dimplex at 1-888-DIMPLEX (1-888-346-7539), or 1367 Industrial Road, Cambridge Ontario, Canada N1R 7G8. Please have proof of purchase, catalogue/model and serial numbers available when calling. Limited warranty service requires a proof of purchase of the product.

### *What Dimplex will do in the event of a defect*

In the event a product or part covered by this limited warranty is proven to be defective in material or workmanship during the 12 month limited warranty period you have the following rights:

- Dimplex will in its sole discretion either repair or replace such defective product or part without charge. If Dimplex is unable to repair or replace such product or part, or if repair or replacement is not commercially practicable or cannot be timely made, Dimplex may, in lieu of repair or replacement, choose to refund the purchase price for such product or part.
- Limited warranty service will be performed solely by dealers or service agents of Dimplex authorized to provide limited warranty services.



- The purchaser is responsible for removal and transportation of such product or part (and any repaired or replacement product or part) to and from the authorized dealer's or service agent's place of business.
- This limited warranty does not entitle the purchaser to on-site or in-home services. On-site or in-home services may be performed at the purchaser's specific request and expense at Dimplex's then-current rates for such services.

Dimplex will not be responsible for, and the limited warranty services shall not include, any expense incurred for installation or removal of the product or part (or any replacement product or part) or any labour or transportation costs. Such costs shall be the purchaser's responsibility.

*What Dimplex and its dealers and service agents are also not responsible for:*

IN NO EVENT WILL DIMPLEX, OR ITS DIRECTORS, OFFICERS, OR AGENTS, BE LIABLE TO THE PURCHASER OR ANY THIRD PARTY, WHETHER IN CONTRACT, IN TORT, OR ON ANY OTHER BASIS, FOR ANY INDIRECT, SPECIAL, PUNITIVE, EXEMPLARY, CONSEQUENTIAL, OR INCIDENTAL LOSS, COST, OR DAMAGE ARISING OUT OF OR IN CONNECTION WITH THE SALE, MAINTENANCE, USE, OR INABILITY TO USE THE PRODUCT, EVEN IF DIMPLEX OR ITS DIRECTORS, OFFICERS, OR AGENTS HAVE BEEN ADVISED OF THE POSSIBILITY OF SUCH LOSSES, COSTS OR DAMAGES, OR IF SUCH LOSSES, COSTS, OR DAMAGES ARE FORESEEABLE. IN NO EVENT WILL DIMPLEX, OR ITS OFFICERS, DIRECTORS, OR AGENTS BE LIABLE FOR ANY DIRECT LOSSES, COSTS, OR DAMAGES THAT EXCEED THE PURCHASE PRICE OF THE PRODUCT.

SOME JURISDICTIONS DO NOT ALLOW THE EXCLUSION OR LIMITATION OF INCIDENTAL OR CONSEQUENTIAL DAMAGES, SO THE ABOVE LIMITATION OR EXCLUSION MAY NOT APPLY TO THE PURCHASER.

*How State and Provincial law apply*

This limited warranty gives you specific legal rights, and you may also have other rights which vary from jurisdiction to jurisdiction. The provisions of the United Nations Convention on Contracts for the Sale of Goods shall not apply to this limited warranty or the sale of products covered by this limited warranty.



1-888-346-7539

**Dimplex**

North America Limited

1367 Industrial Road  
Cambridge, Ontario  
Canada, N1R 7G8