

S/M No. : R41951S001

# Service Manual

## Microwave Oven

Model: KOR-41951S

DAEWOO

**✓ Caution**

: In this Manual, some parts can be changed for improving, their performance without notice in the parts list. So, if you need the latest parts information, please refer to PPL(Parts Price List) in Service Information Center (<http://svc.dwe.co.kr>).

**DAEWOO ELECTRONICS CORP.**

<http://svc.dwe.co.kr>

Jul. 2004

# **PRECAUTIONS TO BE OBSERVED BEFORE AND DURING SERVICING TO AVOID POSSIBLE EXPOSURE TO EXCESSIVE MICROWAVE ENERGY**

- (a) Do not operate or allow the oven to be operated with the door open.
- (b) Make the following safety checks on all ovens to be serviced before activating the magnetron or other microwave source, and make repairs as necessary: (1) Interlock operation, (2) Proper door closing, (3) Seal and sealing surfaces (arcing, wear, and other damage), (4) Damage to or loosening of hinges and latches, (5) Evidence of dropping or abuse.
- (c) Before turning on power to the microwave oven for any service test or inspection within the microwave generating compartments, check the magnetron, wave guide or transmission line, and cavity for proper alignment, integrity, and connections.
- (d) Any defective or misadjusted components in the interlock, monitor, door seal, and microwave generation and transmission systems shall be repaired, replaced, or adjusted by procedures described in this manual before the oven is released to the owner.
- (e) A microwave leakage check to verify compliance with the Federal performance standard should be performed on each oven prior to release to the owner.

## **TABLE OF CONTENTS**

<b>SAFETY AND PRECAUTIONS</b> .....	<b>2</b>
1. FOR SAFE OPERATION .....	2
2. FOR SAFE SERVICE PROCEDURES .....	2
<b>SPECIFICATIONS</b> .....	<b>3</b>
<b>EXTERNAL VIEW</b> .....	<b>4</b>
1. OUTER DIMENSION .....	4
2. FEATURE DIAGRAM .....	5
<b>INSTALLATION</b> .....	<b>6</b>
<b>OPERATIONS AND FUNCTIONS</b> .....	<b>7</b>
<b>DISASSEMBLY AND ASSEMBLY</b> .....	<b>8</b>
<b>INTERLOCK MECHANISM AND ADJUSTMENT</b> .....	<b>15</b>
<b>TROUBLESHOOTING GUIDE</b> .....	<b>16</b>
<b>MEASUREMENT AND TEST</b> .....	<b>18</b>
1. MEASUREMENT OF THE MICROWAVE POWER OUTPUT .....	18
2. MICROWAVE RADIATION TEST .....	19
3. COMPONENT TEST PROCEDURE .....	20
<b>WIRING DIAGRAM</b> .....	<b>21</b>
<b>EXPLODED VIEW AND PARTS LIST</b> .....	<b>22</b>
1. DOOR ASSEMBLY .....	22
2. CONTROL PANEL ASSEMBLY .....	22
3. TOTAL ASSEMBLY .....	22

# SAFETY AND PRECAUTIONS

---

## 1. FOR SAFE OPERATION

Damage that allows the microwave energy (that cooks or heats the food) to escape will result in poor cooking and may cause serious bodily injury to the operator.

IF ANY OF THE FOLLOWING CONDITIONS EXIST, OPERATOR MUST NOT USE THE APPLIANCE.

(Only a trained service personnel should make repairs.)

- (1) A broken door hinge.
- (2) A broken door viewing screen.
- (3) A broken front panel, oven cavity.
- (4) A loosened door lock.
- (5) A broken door lock.

The door gasket plate and oven cavity surface should be kept clean.

No grease, soil or spatter should be allowed to build up on these surfaces or inside the oven.

DO NOT ATTEMPT TO OPERATE THIS APPLIANCE WITH THE DOOR OPEN.

The microwave oven has concealed switches to make sure the power is turned off when the door is opened.

Do not attempt to defeat them.

DO NOT ATTEMPT TO SERVICE THIS APPLIANCE UNTIL YOU HAVE READ THIS SERVICE MANUAL.

## 2. FOR SAFE SERVICE PROCEDURES

1. If the oven is operative prior to servicing, a microwave emission check should be performed prior to servicing the oven.
2. If any certified oven unit is found to servicing, a microwave emission check should be performed prior to servicing the oven.
  - (a) inform the manufacturer, importer or assembler,
  - (b) repair the unit at no cost to the owner,
  - (c) attempt to ascertain the cause of the excessive leakage,
  - (d) tell the owner of the unit not to use the unit until the oven has been brought into compliance.
3. If the oven operates with the door open, the service person should tell the user not to operate the oven and contact the manufacturer and the dealer immediately.

### IMPORTANT

The wire in this mains lead coloured in accordance with the following code.

Green-and-yellow : Each

Blue : Neutral

Brown : Live

As the colours of the wires in the mains lead of this appliance may not correspond with the coloured markings identifying the terminals in your plug, proceed as follows.

The wire which is coloured green-and-yellow must be connected to the terminal in the plug which is marked with the letter 'E', earth symbol or coloured green-and-yellow.

The wire which is coloured blue must be connected to the terminal which is marked with the letter 'N' or coloured black.

The wire which is coloured brown must be connected to the terminal which is marked with the letter 'L' or coloured red.

### NOTE

This oven is designed for counter-top use only.

# **SPECIFICATIONS**

---

<b>MODEL</b>	<b>KOR-41951S</b>
POWER SUPPLY	230V~50Hz, SINGLE PHASE WITH GROUNDING
POWER CONSUMPTION MICROWAVE	920 W
MICROWAVE ENERGY OUTPUT	600 W
MICROWAVE FREQUENCY	2450 MHz
OUTSIDE DIMENSIONS (W X H X D)	444 x 235 x 346 mm (17.5 x 9.3 x 13.6 in)
CAVITY DIMENSIONS (W X H X D)	265 x 172 x 270 mm (10.4 x 6.8 x 10.6 in.)
NET WEIGHT	Approx. 10.6 kg (23.4 lbs.)
TIMER	35 MIN. DUAL SPEED
FUNCTION SELECTIONS	MICROWAVE
POWER SELECTIONS	5 LEVELS
CAVITY VOLUME	0.4 Cu. Ft.

*\* SPECIFICATIONS ARE SUBJECT TO CHANGE WITHOUT NOTICE.*

# EXTERNAL VIEW

---

## 1. OUTER DIMENSION

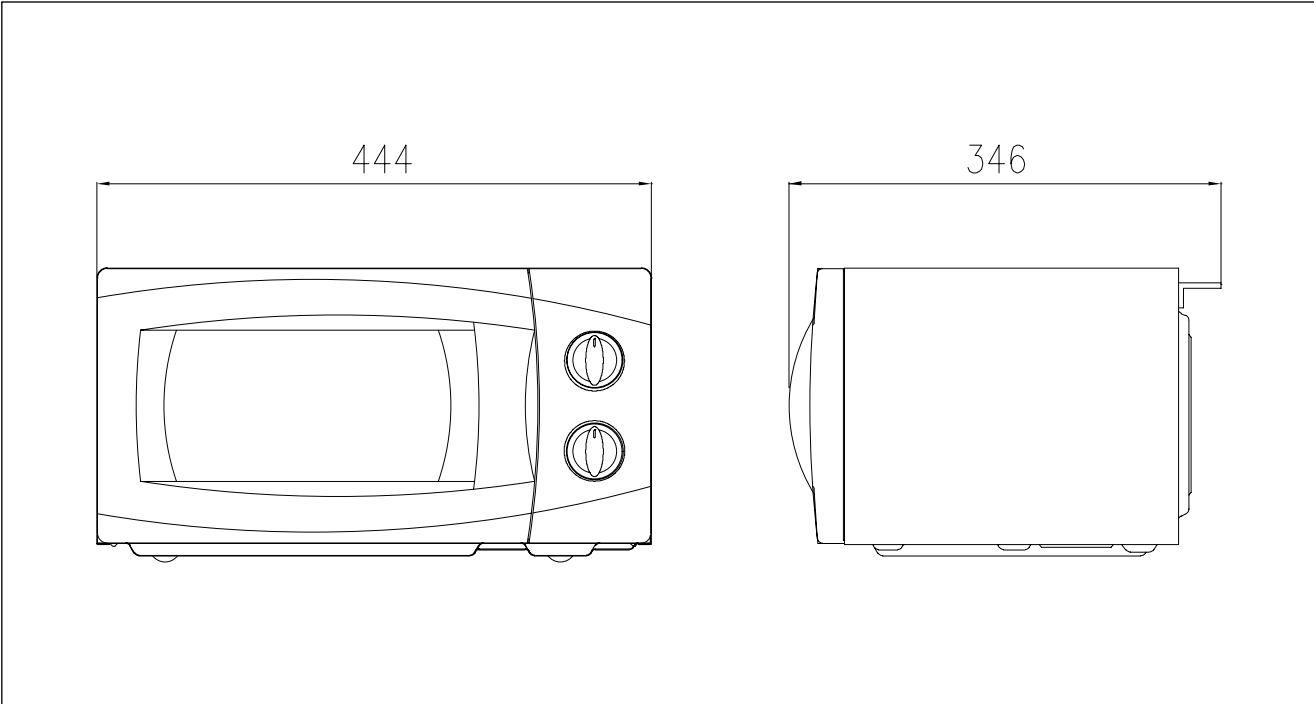

## 2. FEATURE DIAGRAM

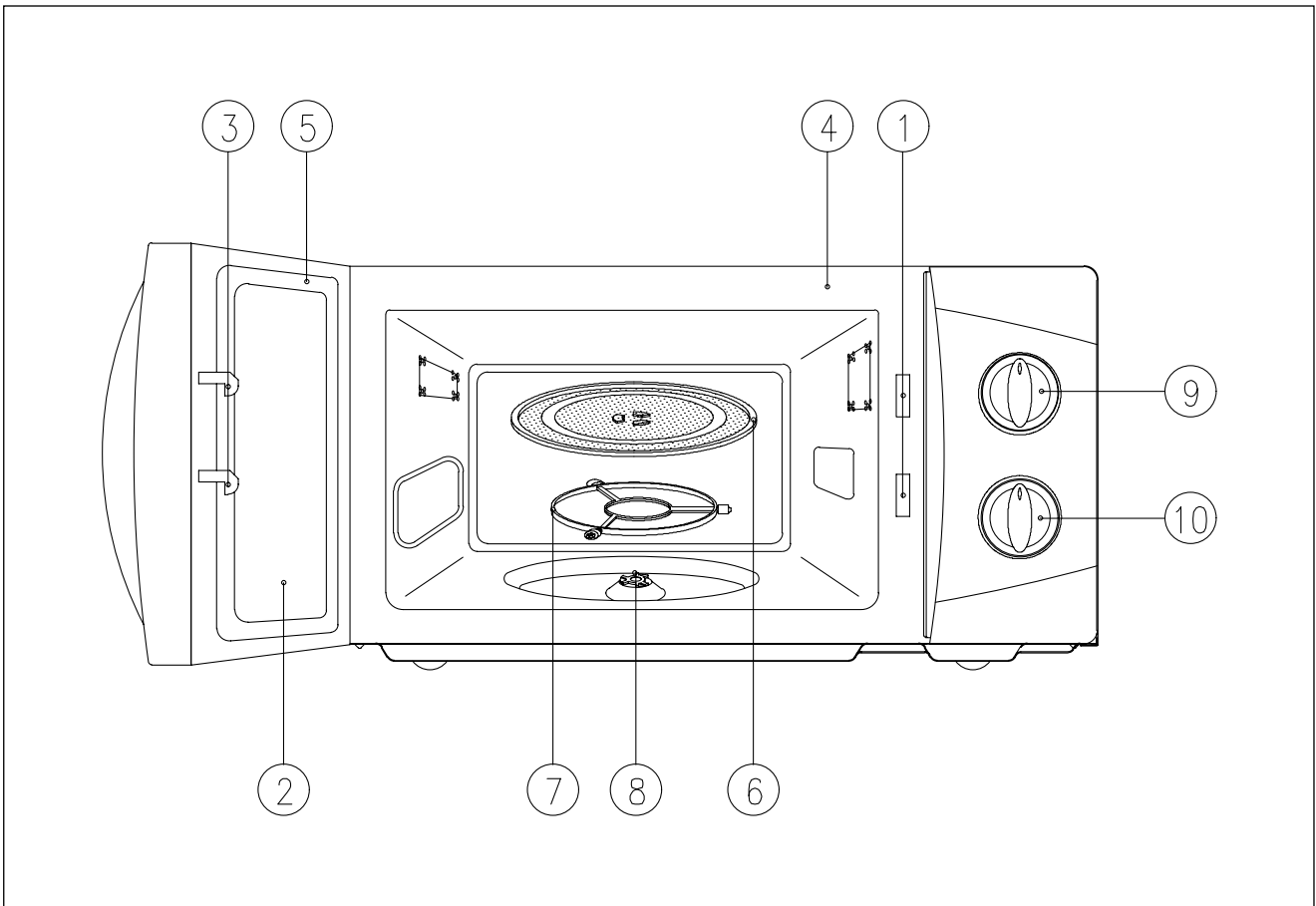

### 1. SAFETY INTERLOCK SYSTEM

### 2. DOORVIEWING SCREEN

Allows viewing of food. The screen is designed so that light can pass through, but not the microwave.

### 3. DOOR HOOK

When the door is closed, it will automatically lock shut. If door is opened while oven is operating, magnetron tube will immediately stop operating.

### 4. OVEN CAVITY

### 5. DOOR SEAL

Door seal maintains the microwave within the oven cavity and prevents microwave leakage.

### 6. GLASS COOKING TRAY

Made of special heat resistant glass. Food in a proper receptacle is placed on this tray for cooking.

### 7. ROLLER GUIDE

This must always be used for cooking together with the glass cooking tray.

### 8. COUPLER

This fits over the shaft in the center of the ovens cavity floor. This is to remain in the oven for all cooking.

### 9. KNOB V.P.C.

Used to select a microwave power level.

### 10. KNOB TIMER

Used in setting cooking time for all functions.

# INSTALLATION

---

## 1. Steady, flat location.

This microwave oven should be set on a steady, flat surface.

## 2. Leave space behind and side.

All air vents should be kept a clearance. If all vents are covered during operation, the oven may be overheated and, eventually, cause oven failure.

## 3. Away from radio, and TV sets

Poor television reception and radio interference may result if the oven is located close to a TV, radio, antenna, or feeder and so on.

## 4. Away from heating appliances and water taps

Keep the oven away from hot air, steam or splash when choosing a place to position it, or the insulation might be adversely affected and breakdowns occur.

## 5. Power supply

- Check your local power source.  
This microwave oven requires a current of approximately 12 amperes, 230 Volts, 50 Hz.
- Power supply cord is about 1 meters long.
- The voltage used must be the same as specified on this oven. Using a higher voltage may result in a fire or other accident causing oven damage. Using low voltage will cause slow cooking. We are not responsible for damage resulting from use of this oven with a voltage of ampere fuse other than those specified.
- This appliance is supplied with cable of special type, which, if damaged, must be repaired with cable of same type.  
Such a cable can be purchased from DAEWOO and must be installed by a qualified person.

## 6. Examine the oven after unpacking for any damage such as:

A misaligned door, broken door or a dent in cavity.

If any of the above are visible, DO NOT INSTALL, and notify dealer immediately.

## 7. Do not operate the oven if it is colder than room temperature

(This may occur during delivery in cold weather.) Allow the oven to become room temperature before operating.

## EARTHING INSTRUCTIONS

This appliance must be earthed. In the event of an electrical short circuit, earthing reduces the risk of the electric shock by providing an escape wire for the electric current. This appliance is equipped with a cord having a earthing plug. The plug must be plugged into an outlet that is properly installed and earthed.

### WARNING

Improper use of the earthing plug can result in a risk of electric shock. Consult a qualified electrician or service-man if the earthing instructions are not completely understood, or if doubt exists as to whether the appliance is properly earthed, and either : If it is necessary to use an extension cord, use only a 3-wire extension cord that has a 3-blade earthing plug, and a 3-slot receptacle that will accept the plug on the appliance. The marked rating of the extension cord should be equal to or greater than the electrical rating of the appliance, or Do not use an extension cord.

# OPERATIONS AND FUNCTIONS

1. Connect the main lead to an electrical outlet.
2. After placing the food in a suitable container, open the oven door and put it on the glass tray. The glass tray must always be in place during cooking.
3. Close the door securely.
4. Choose cooking power level by setting V.P.C knob to the desired position. Refer to cookbook for recommended power levels.
5. Determine cooking time. Consult cookbook for recipe timing. Oven light turns on and cooling fan starts to operate. Microwave cooking starts.
6. You may open the door while the oven is operating. As soon as the door is opened, the safety mechanisms stop the generation of microwave power and the operation of cooking timer.  
If you wish to change the time during cooking, simply adjust the timer to the desired time.
7. When the timer reaches zero, a bell will ring and the unit will turn off. Oven light turns off. If additional cooking time is needed and the door is closed, the oven will automatically start when the timer is reset.

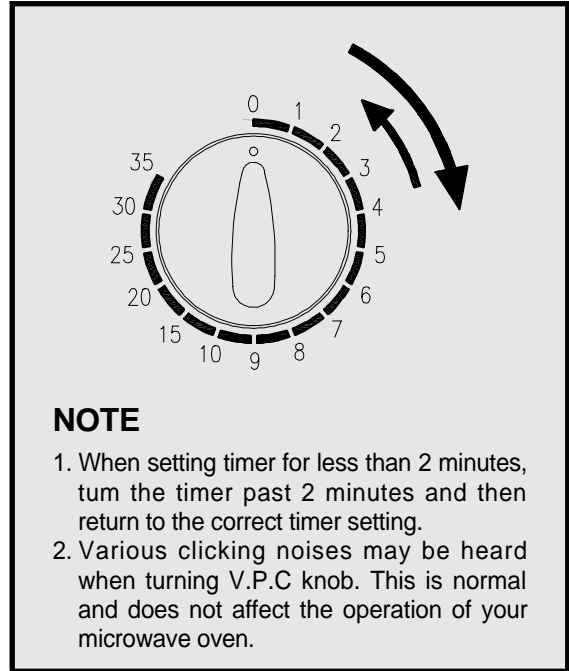

Make sure the oven is properly installed and plugged into the electrical outlet.

## Variable power cooking

ON and OFF cycle time of mechanical V.P.C switch is 30 seconds.

When the V.P.C knob is set to the desired position and timer knob to the desired position, the V.P.C switch has a cycle (ON/OFF time(sec.)) listed below.

Variable power setting		Approximate Percentage of Power
Power level	Symbol	
HIGH		100%
MED HIGH		77%
MEDIUM		55%
DEFROST		33%
WARM		17%



# DISASSEMBLY AND ASSEMBLY

## Cautions to be observed when troubleshooting.

Unlike many other appliances, the microwave oven is high-voltage, high-current equipment. It is completely safe during normal operation.

However, carelessness in servicing the oven can result in an electric shock or possible danger from a short circuit. You are asked to observe the following precautions carefully.

1. Always remove the power plug from the outlet before servicing.
2. Use an insulated screwdriver and wear rubber gloves when servicing the high voltage side.
3. Discharge the high voltage capacitor before touching any oven components or wiring.

(1) Check the grounding.

Do not operate on a two-wire extension cord. The microwave oven is designed to be used while earthed. It is imperative, therefore, to make sure it is earthed properly before beginning repair work.

(2) Warning about the electric charge in the high voltage capacitor.

For about 30 seconds after the operation stopped and electric charge remains in the high voltage capacitor.

When replacing or checking parts, short between oven chassis and the negative high terminal of the high voltage capacitor by using a properly insulated screwdriver to discharge.

4. When the 12A fuse is blown out due to the operation of the monitor switch; replace primary interlock switch, secondary interlock switch and interlock monitor switch.
5. After repair or replacement of parts, make sure that the screws are properly tightened, and all electrical connections are tightened.
6. Do not operate without cabinet.

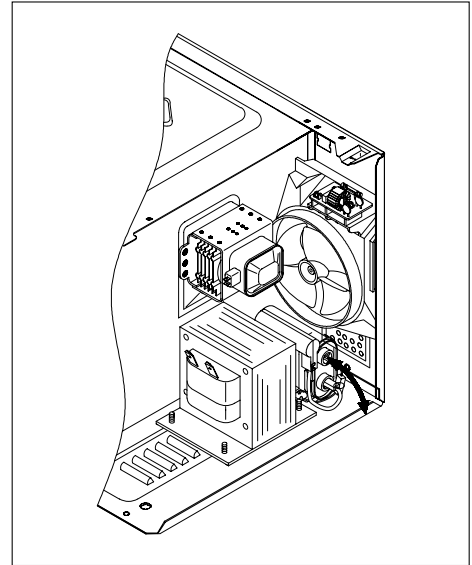

**CAUTION** : Service personnel should remove their watches whenever working close to or replacing the magnetron.

**WARNING** : When servicing the appliance, need a care of touching or replacing high potential parts because of electrical shock or exposing microwave. These parts are as follows - HV Transformer, Magnetron, HV Capacitor, HV Diode, HV fuse.

## 1. To remove cabinet

- 1) Remove three screws on cabinet back.
- 2) Pull the cabinet backward.

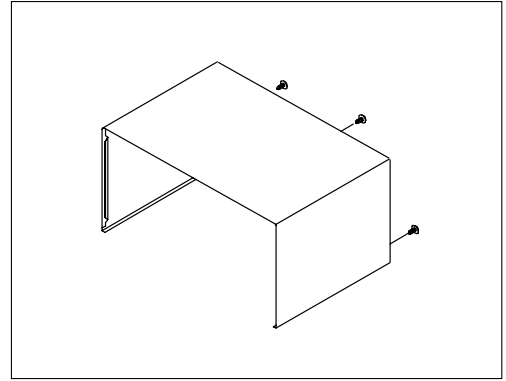

## 2. To remove door assembly

- 1) Remove a screw which secure the stopper hinge top.
- 2) Remove the door assembly from top plate of cavity.
- 3) Reverse the above for reassembly.

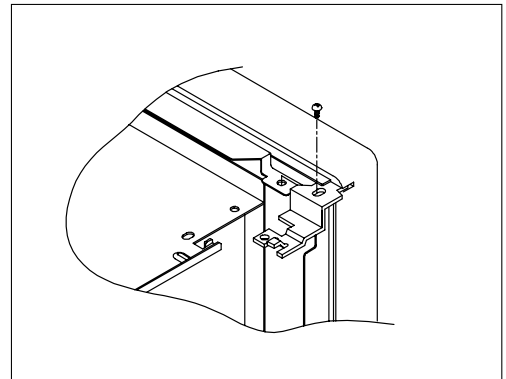

**NOTE :** After replacing the door assembly, perform a check of correct alignment with the hinge and cavity front plate.

✓ **Caution** : In this Service Manual, some parts can be changed for improving, their performance without notice in the parts list. So, if you need the latest parts information, please refer to PPL(Parts Price List) in Service Information Center (<http://svc.dwe.co.kr>).

### 3. To remove door parts.

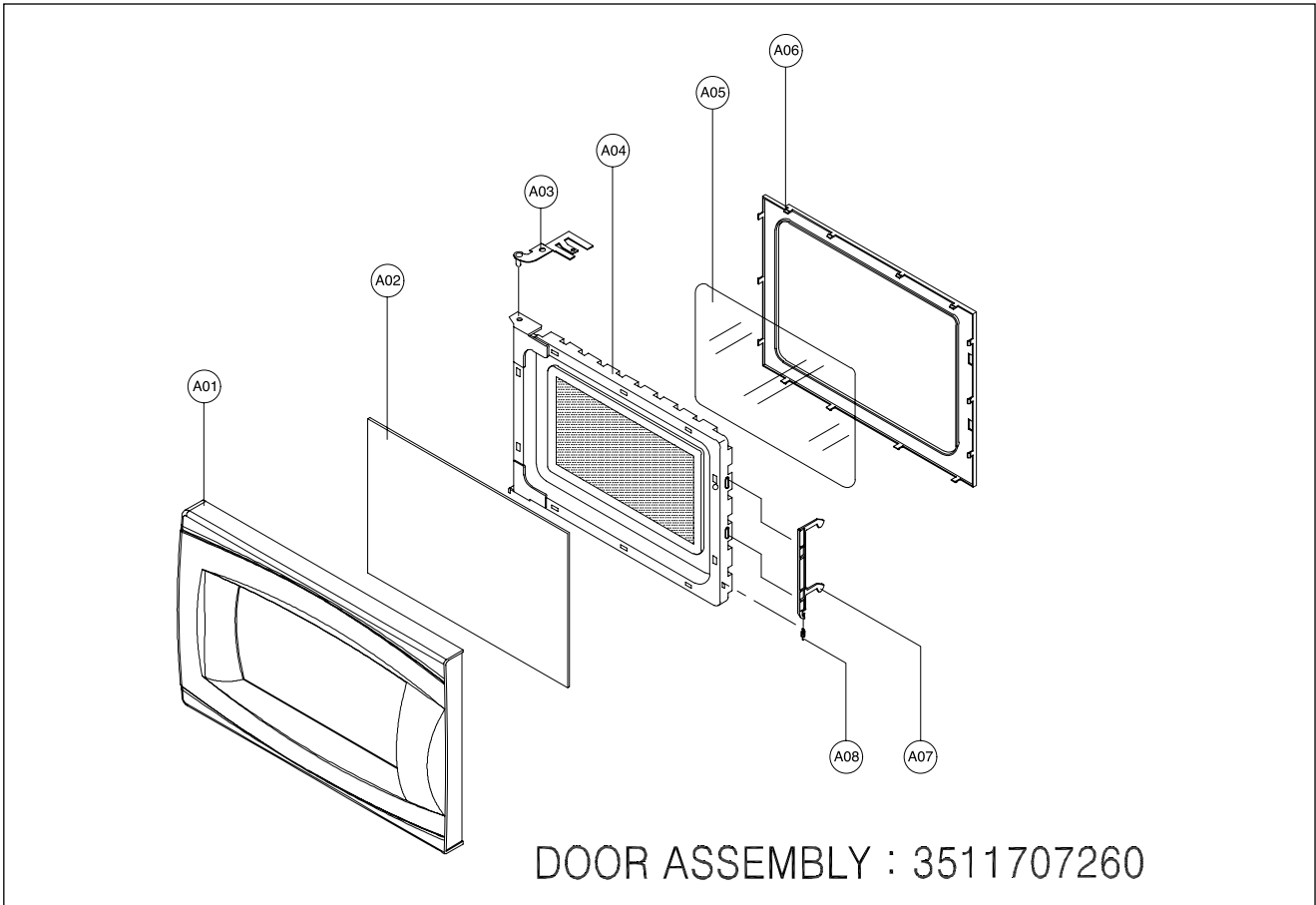

REF NO.	PART CODE	PART NAME	DESCRIPTION	Q'TY	REMARK
A01	3512208810	FRAME DOOR	HIPS SG-970 HG-1760H	1	
A02	3517003880	BARRIER-SCREEN *O	PET TO. 125	1	
A03	3515202400	STOPPER HINGE *T AS	KOR-41125J	1	
A04	3511707600	DOOR PAINTING AS	KOR-41125J	1	
A05	3517003700	BARRIER-SCREEN *I	POLYESTER T0.1	1	
A06	3512300600	GASKET DOOR	PP	1	
A07	3513100801	HOOK	POM	1	
A08	3515101310	SPRING HOOK	HSW-3	1	

- (1) Remove the gasket door from door weld as.
- (2) Remove the barrier screen inner from door weld as.
- (3) Remove the door frame from door weld as.
- (4) Remove the stopper hinge top from door weld as.
- (5) Remove the spring and the hook.
- (6) Remove the barrier screen outer from door frame.
- (7) Reverse the above steps for reassembly.

---

#### 4. Method to reduce the gap between the door seal and the oven front surface.

(1) To reduce gap located on part 'A'

- Loosen a screw on stopper hinge top, and then push the door to contact the door seal to oven front surface.
- Tighten one screw.

(2) To reduce gap located on part 'B'

- Loosen two screws on stopper hinge under, and then push the door to contact the door seal to oven front surface.
- Tighten two screws.

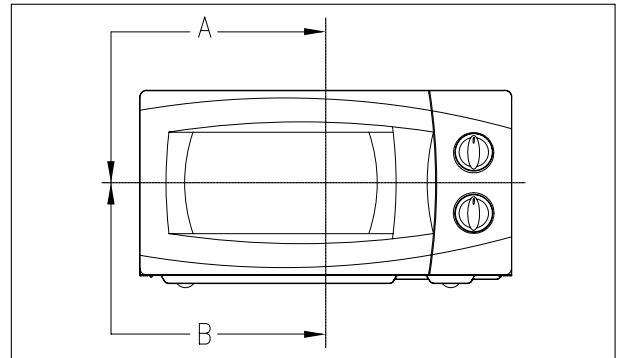

**NOTE :** A small gap may be acceptable if the microwave leakage does not exceed  $4\text{mW}/\text{cm}^2$ .

✓ **Caution** : In this Service Manual, some parts can be changed for improving, their performance without notice in the parts list. So, if you need the latest parts information, please refer to PPL(Parts Price List) in Service Information Center (<http://svc.dwe.co.kr>).

## 5. To remove control panel parts.

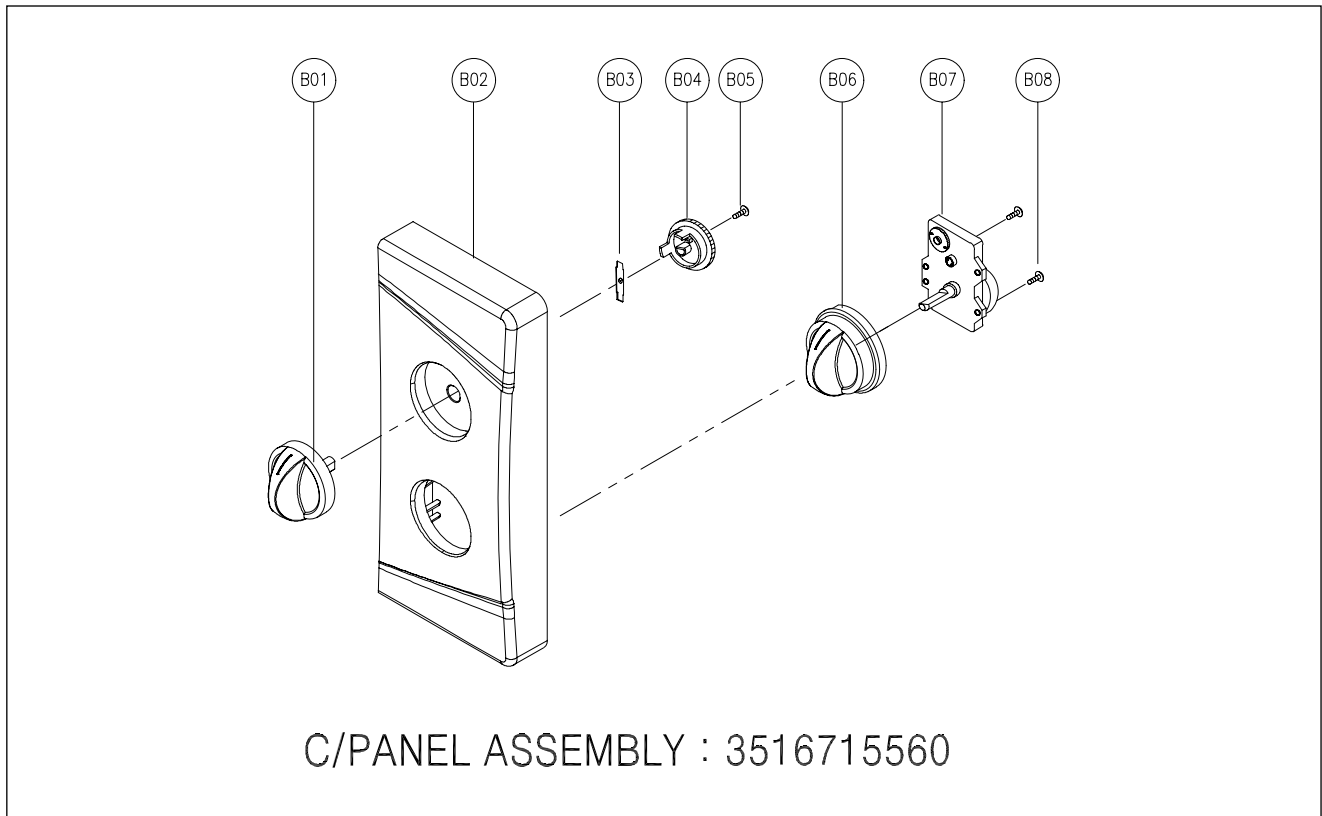

REF NO.	PART CODE	PART NAME	DESCRIPTION	Q'TY	REMARK
B01	3513403760	KNOB VPC	ABS SG-175 SG-0760D	1	
B02	3516732110	CONTROL-PANEL	HIPS SG-970 HG-1760H	1	
B03	3515101600	SPRING FLAT	SUS 301 T0.5	1	
B04	3517401020	COUPLER VPC KNOB	POM	1	
B05	7122401211	SCREW TAPPING	T2S TRS 4X12 MFZN	1	
B06	3513403660	KNOB	ABS SG-175 SG-0760D	1	
B07	3518204720	TIMER	MTHK135ND	1	
B08	7122401211	SCREW TAPPING	T2S TRS 4X12 MFZN	2	

- (1) Remove the screw which secure the control panel, push up two snap fits and draw forward the control panel assembly.
- (2) Remove two screws which secure the timer assembly.
- (3) Remove the timer assembly.
- (4) Pull out the timer knob from the timer.
- (5) Remove the screw which secure the coupler.
- (6) Pull out the coupler, V.P.C knob and flat spring from the control panel.
- (7) Reverse the above steps for reassembly.

## 6. To remove high voltage capacitor.

- 1) Remove a screw which secure the grounding ring terminal of the H.V. diode and the capacitor holder.
- 2) Remove the H.V. diode from the capacitor holder.
- 3) Reverse the above steps for reassembly.

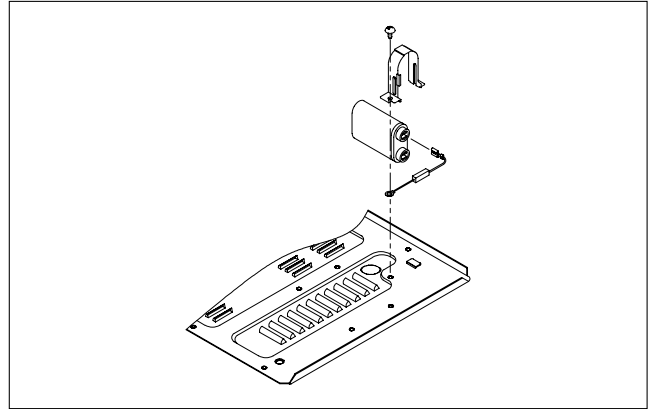

## ◆ High voltage circuit wiring

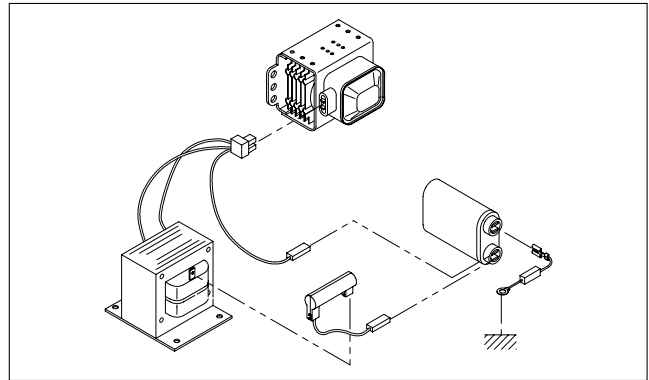

## 7. To remove magnetron.

- 1) Remove a screw which secure the magnetron.
- 2) Remove the magnetron.
- 3) Reverse the above steps for reassembly.

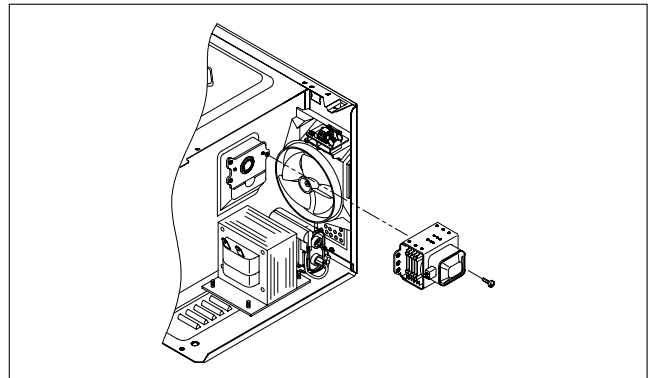

**NOTE :** Never install the magnetron without the metallic gasket plate which is packed with each magnetron to prevent microwave leakage. Whenever repair work is carried out on magnetron, check the microwave leakage. It shall not exceed  $4\text{mW}/\text{cm}^2$  for a fully assembled oven with door normally closed.

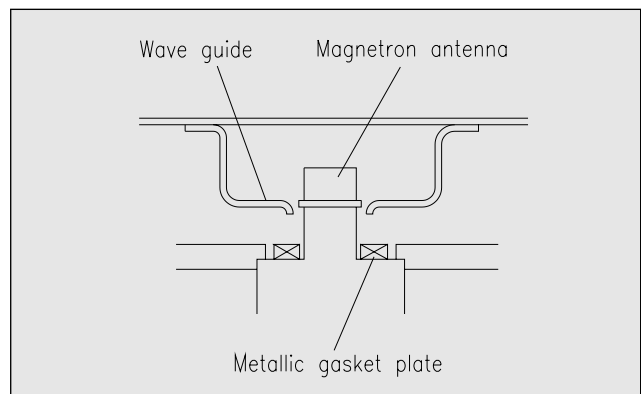
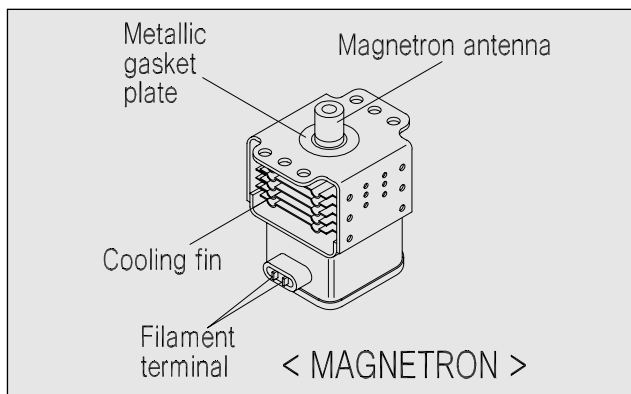

## 8. To remove wind guide assembly.

- 1) Remove a screw for earthing.
- 2) Remove the noise filter from the wind guide.
- 3) Remove a screw which secure the wind guide assembly.
- 4) Draw forward the wind guide assembly.
- 5) Pull the fan from the motor shaft.
- 6) Remove two screws which secure the motor shaded pole.
- 7) Remove the motor shaded pole.
- 8) Reverse the above steps for reassembly.

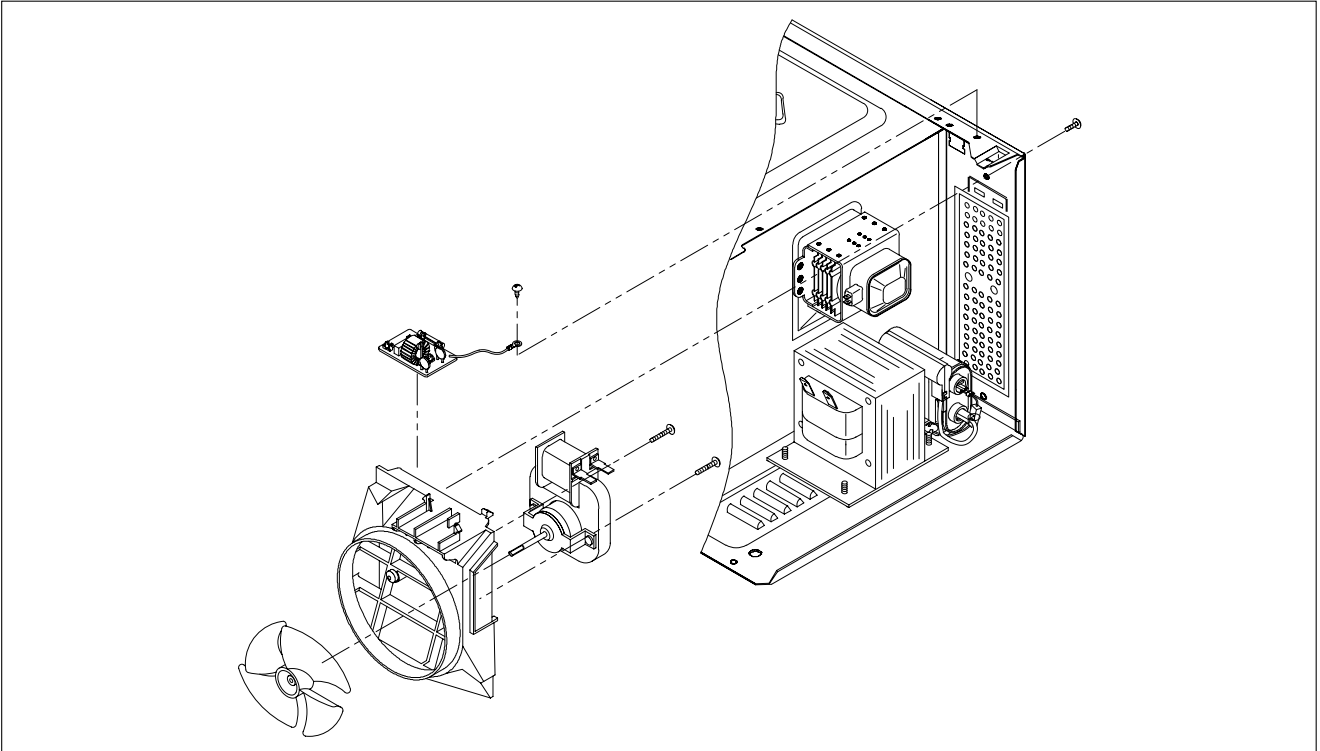

## 9. To remove H.V.transformer.

- 1) Remove four screws holding the H.V. transformer.
- 2) Remove the H.V. transformer.
- 3) Reverse the above steps for reassembly.

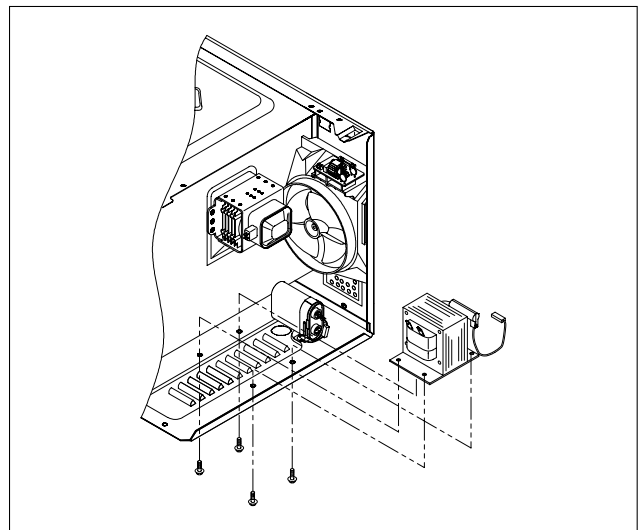

# INTERLOCK MECHANISM AND ADJUSTMENT

The door lock mechanism is a device which has been specially designed to completely eliminate microwave radiation when the door is opened during operation, and thus to perfectly prevent the danger resulting from the leakage of microwave.

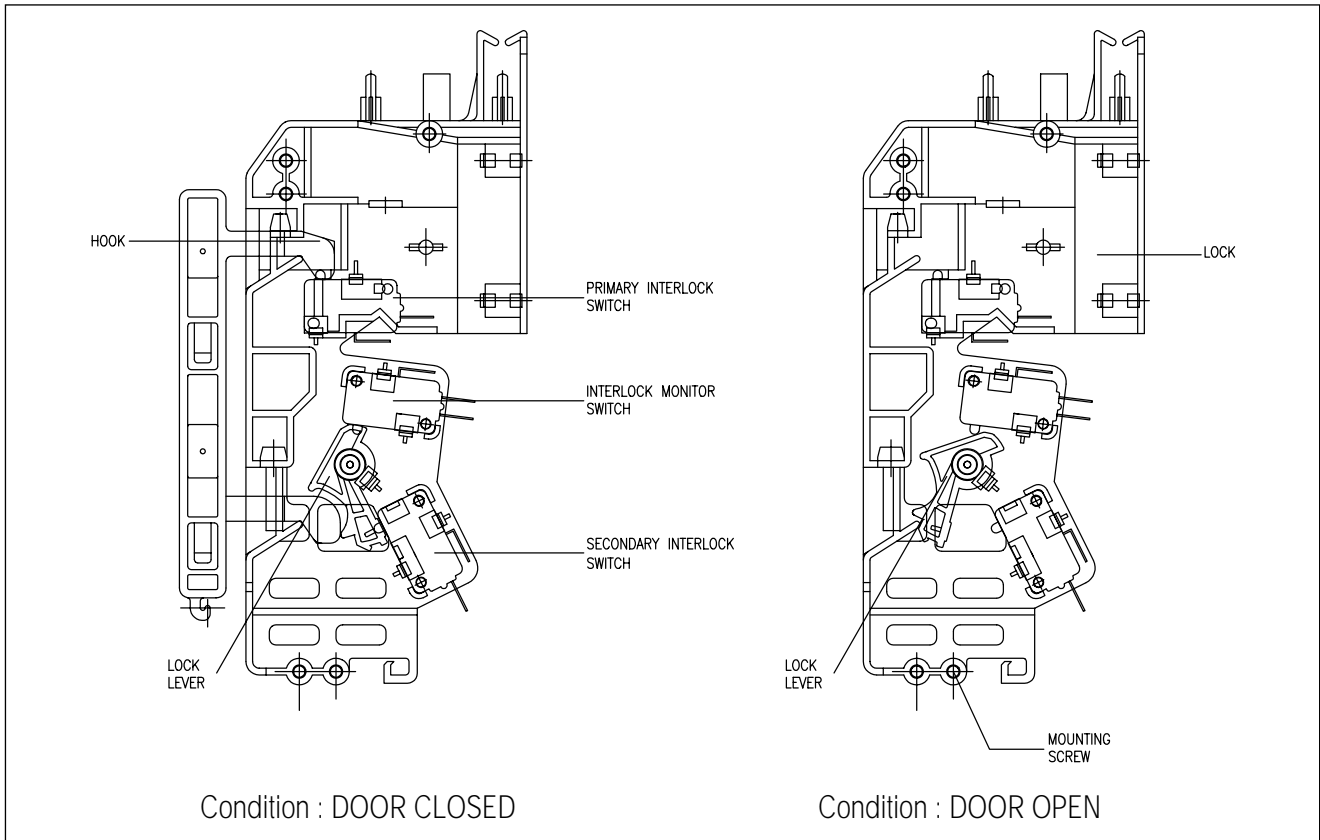

## (1) Primary interlock switch

When the door is closed, the hook locks the oven door. If the door is not closed properly, the oven will not operate. When the door is closed, the hook pushes the button of the microswitch. Then the button of the primary interlock switch bring it under ON condition.

## (2) Secondary interlock switch and interlock monitor switch

When the door is closed, the hook pushes the lock lever downward. The lock lever presses the button of the interlock monitor switch to bring it under NO condition and presses the button of the secondary interlock switch to bring it under ON condition.

### ADJUSTMENT :

Interlock monitor switch

When the door is closed, the interlock monitor switch should be "OFF" condition before other switches are "ON" condition.

When the door is opened, the interlock monitor switch should be "ON" condition after other switches are "OFF" condition.

## (3) Adjustment steps

- a) Loosen the one mounting screw.
- b) Adjust interlock switch assembly position.
- c) Make sure that lock lever moves smoothly after adjustment is completed.
- d) Tighten completely one mounting screw.

### NOTE :

Microwave emission test should be performed after adjusting interlock mechanism. If the microwave emission exceed  $4\text{mW}/\text{cm}^2$ , readjust interlock mechanism.



# TROUBLESHOOTING GUIDE

Following the procedure below to check if the oven is defective or not.

1. Check grounding before trouble checking.
2. Be careful of the high voltage circuit.
3. Discharge the high voltage capacitor.
4. When checking the continuity of the switches, fuse or high voltage transformer, disconnect one lead wire from these parts and check continuity with the AC plug removed. To do otherwise may result in a false reading or damage to your meter.

**(TROUBLE 1) Door shut, timer set, but no cooking takes place.**

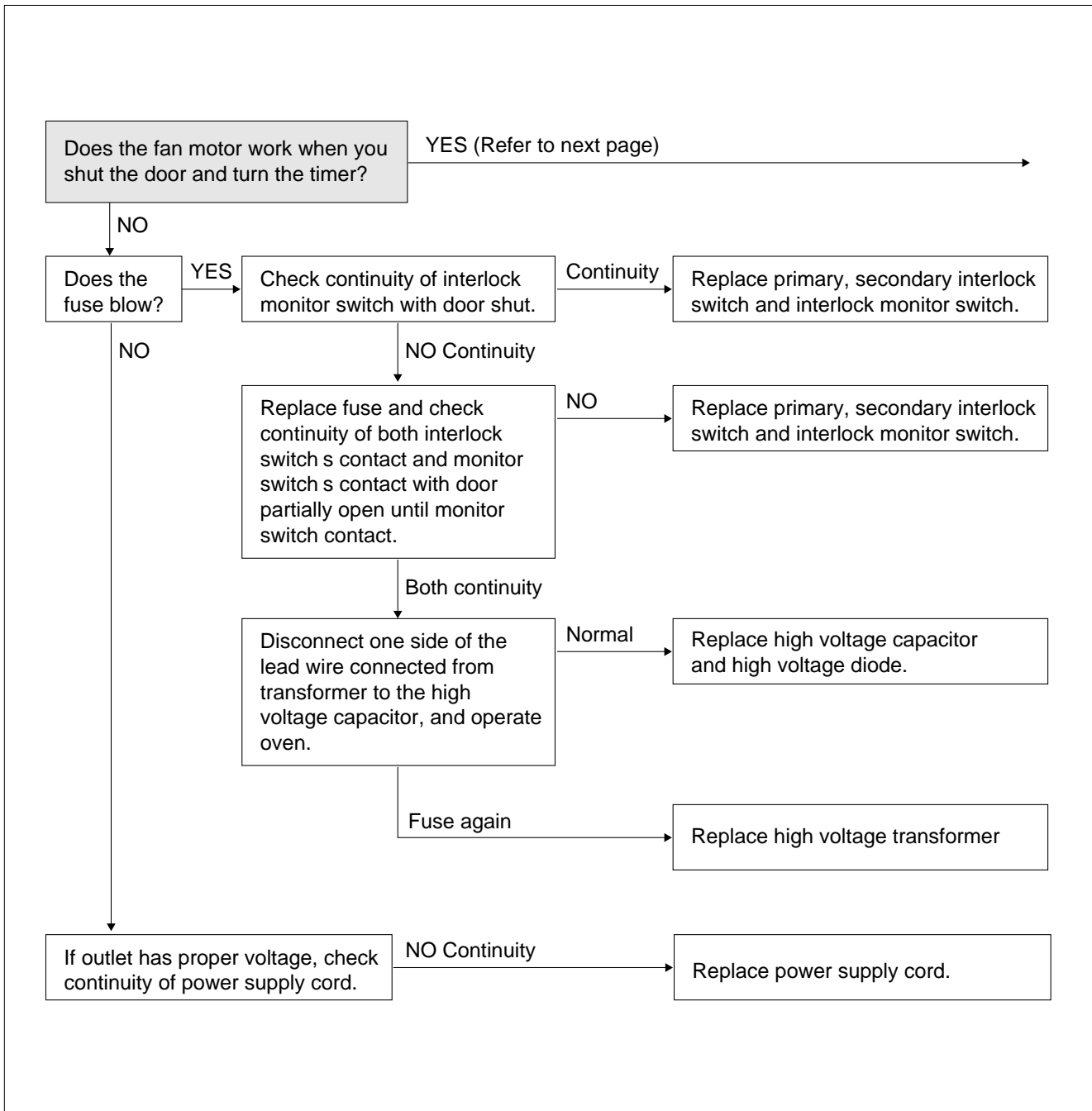

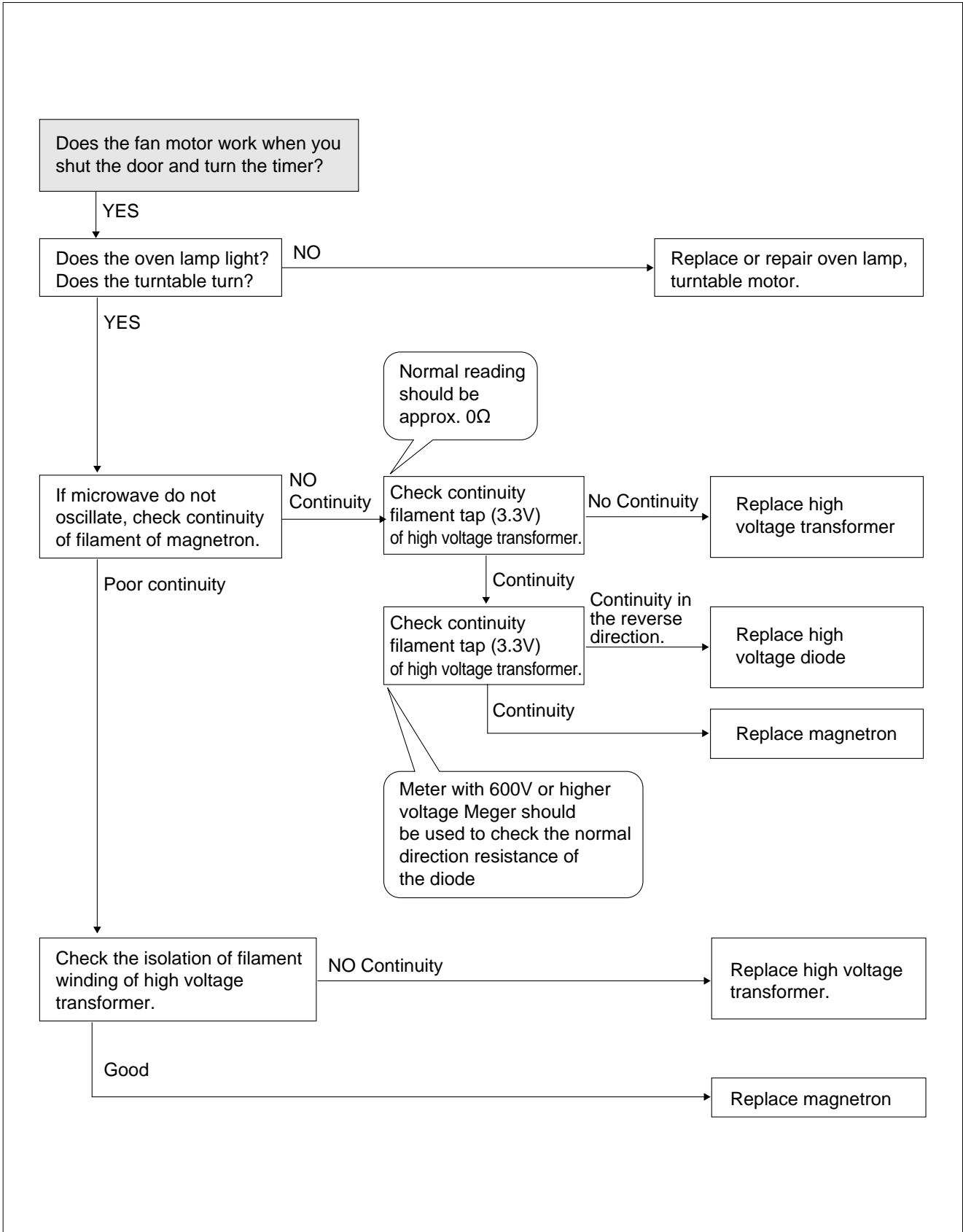

# MEASUREMENT AND TEST

## 1. MEASUREMENT OF THE MICROWAVE POWER OUTPUT

Microwave output power can be checked by indirectly measuring the temperature rise of a certain amount of water exposed to the microwave as directed below.

### PROCEDURE

1. Microwave power output measurement is made with the microwave oven supplied at rated voltage and operated at its maximum microwave power setting with a load of  $1000 \pm 5$ cc of potable water.
2. The water is contained in a cylindrical borosilicate glass vessel having a maximum material thickness of 3 mm and an outside diameter of approximately 190 mm.
3. The oven and the empty vessel are at ambient temperature prior to the start of the test.

The initial temperature of the water is  $10 \pm 2^\circ\text{C}$  ( $50 \pm 3.6^\circ\text{F}$ )

It is measured immediately before the water is added to the vessel.

After addition of the water to the vessel, the load is immediately placed on the center of the shelf, which is in the lowest normal position.

4. Microwave power is switched on.
5. Heating time should be exactly **A** seconds. (Refer to table as following)  
Heating time is measured while the microwave generator is operating at full power.  
The filament heat-up time for magnetron is not included.
6. The initial and final temperature of water is selected so that the maximum difference between the ambient and final water temperature is 5K.
7. The microwave power output P in watts is calculated from the following formula :

$$P = 4187 \times \Delta T / t$$

- $\Delta T$  is difference between initial and ending temperature.
- t is the heating time.

The power measured should be B (Refer to SPECIFICATIONS)  $\pm 10.0\%$ .

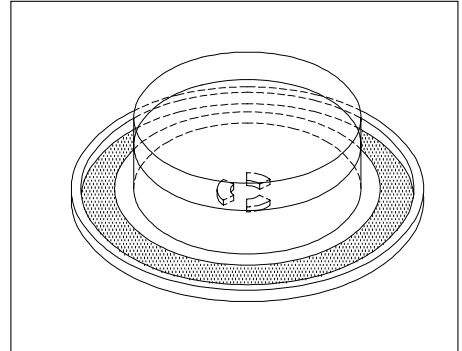

### CAUTION :

1. Water load should be measured exactly to 1 liters.
2. Input power voltage should be exactly specified voltage (Refer to SPECIFICATIONS).
3. Ambient temperature should be  $20 \pm 2^\circ\text{C}$  ( $68 \pm 3.6^\circ\text{F}$ )

Heating time for power output:

<b>A(second)</b>	70	64	60	56	52	49	47	44	42	40	38
<b>B(W)</b>	600	650	700	750	800	850	900	950	1000	1050	1100

## 2. MICROWAVE RADIATION TEST

### WARNING :

Make sure to check the microwave leakage before and after repair of adjustment.

Always start measuring of an unknown field to assure safety for operating personnel from microwave energy.

Do not place your hands into any suspected microwave radiation field unless the safe density level is known.

Care should be taken not to place the eyes in direct line with the source of microwave energy.

Slowly approach the unit under test until the radiometer reads an appreciable microwave leakage from the unit under the test.

### PROCEDURES

1. Prepare Microwave Energy Survey Meter, 600cc glass beaker, and glass thermometer  $100^{\circ}\text{C}$ ( $212^{\circ}\text{F}$ ).
2. Pour  $275\text{cc}\pm 15\text{cc}$  of tap water initially at  $20\pm 5^{\circ}\text{C}$ ( $68\pm 9^{\circ}\text{F}$ ) in the 600cc glass beaker with an inside diameter of approx. 95mm(3.5in.).
3. Place it at the center of the tray and set it in a cavity.
4. Close the door and operate the oven.
5. Measure the leakage by using Microwave Energy Survey Meter with dual ranges, set to 2450MHz.
  - 1) Measured radiation leakage must not exceed the value prescribed below. Leakage for a fully assembled oven with door normally closed must be less than  $4\text{mW}/\text{cm}^2$ .
  - 2) When measuring the leakage, always use the 5cm(2in.) space cone with probe. Hold the probe perpendicular to the cabinet and door. Place the space cone of the probe on the door, cabinet, door seem, door viewing screen, the exhaust air vents and the suction air vents.
  - 3) Measuring should be in a counter-clockwise direction at a rate of 1 in./sec. If the leakage of the cabinet door seem is unknown, move the probe more slowly.
  - 4) When measuring near a corner of the door, keep the probe perpendicular to the areas making sure the probe end at the base of the cone does not get closer than 2 in. from any metal. If it does not, erroneous reading may result.

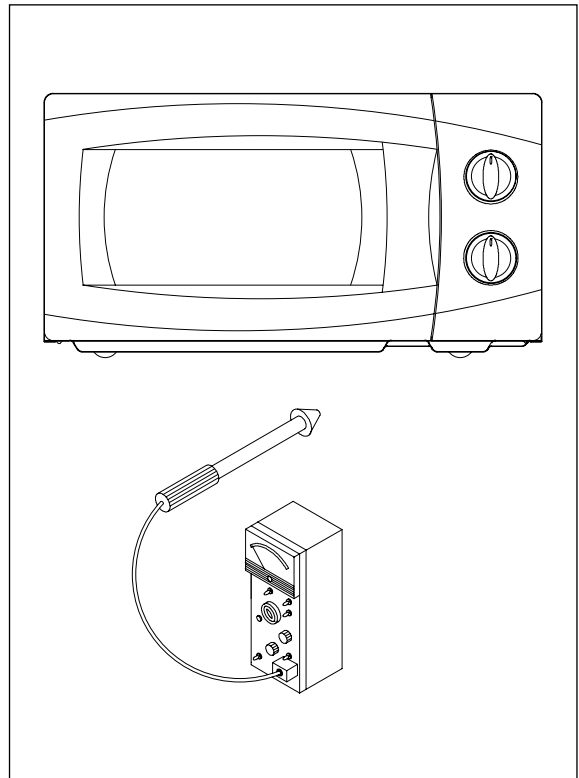

---

### 3. COMPONENT TEST PROCEDURE

- High voltage is present at the high voltage terminal of the high voltage transformer during any cooking cycle.
- It is neither necessary nor advisable to attempt measurement of the high voltage.
- Before touching any oven components or wiring, always unplug the oven from its power source and discharge the capacitor.

#### 1. High voltage transformer

- (1) Remove connections from the transformer terminals and check continuity.
- (2) Normal readings should be as follows(at 20°C):
  - Secondary winding.....Approx.  $170\Omega \pm 10\%$
  - Filament winding.....Approx.  $0\Omega$
  - Primary winding.....Approx.  $2.5 \pm 10\% \Omega$

#### 2. High voltage capacitor

- (1) Check continuity of capacitor with meter on the highest OHM scale.
- (2) A normal capacitor will show continuity for a short time, and then indicate  $10M\Omega$  once the capacitor is charged.
- (3) A shorted capacitor will show continuous continuity.
- (4) An open capacitor will show constant  $10M\Omega$ .
- (5) Resistance between each terminal and chassis should be infinite.

#### 3. High voltage diode

- (1) Isolate the diode from the circuit by disconnecting the leads.
- (2) With the ohmmeter set on the highest resistance scale measure the resistance across the diode terminals.
  - Reverse the meter leads and again observe the resistance reading.
  - Meter with 600V or higher voltage Meger should be used to check the front-back resistance of the diode, otherwise an infinite resistance may be read in both directions.
  - A normal diode s resistance will be infinite in one direction and several hundred  $K\Omega$  in the other direction.

#### 4. Magnetron

For complete magnetron diagnosis, refer to "Measurement of the Microwave Power Output".

Continuity checks can only indicate an open filament or a shorted magnetron.

To diagnose for an open filament or a shorted magnetron.

- (1) Isolate magnetron from the circuit by disconnecting the leads.
- (2) A continuity check across magnetron filament terminals should indicate  $0.1\Omega$  or less.
- (3) A continuity check between each filament terminal and magnetron case should read open.

#### 5. Fuse

If the fuse in the primary and monitor switch circuit is blown when the door is opened, check the primary and monitor switch before replacing the blown fuse.

In case the fuse is blown by an improper switch operation, replace the defective switch and fuse at the same time.

Replace just the fuse if the switches operate normally.

# WIRING DIAGRAM

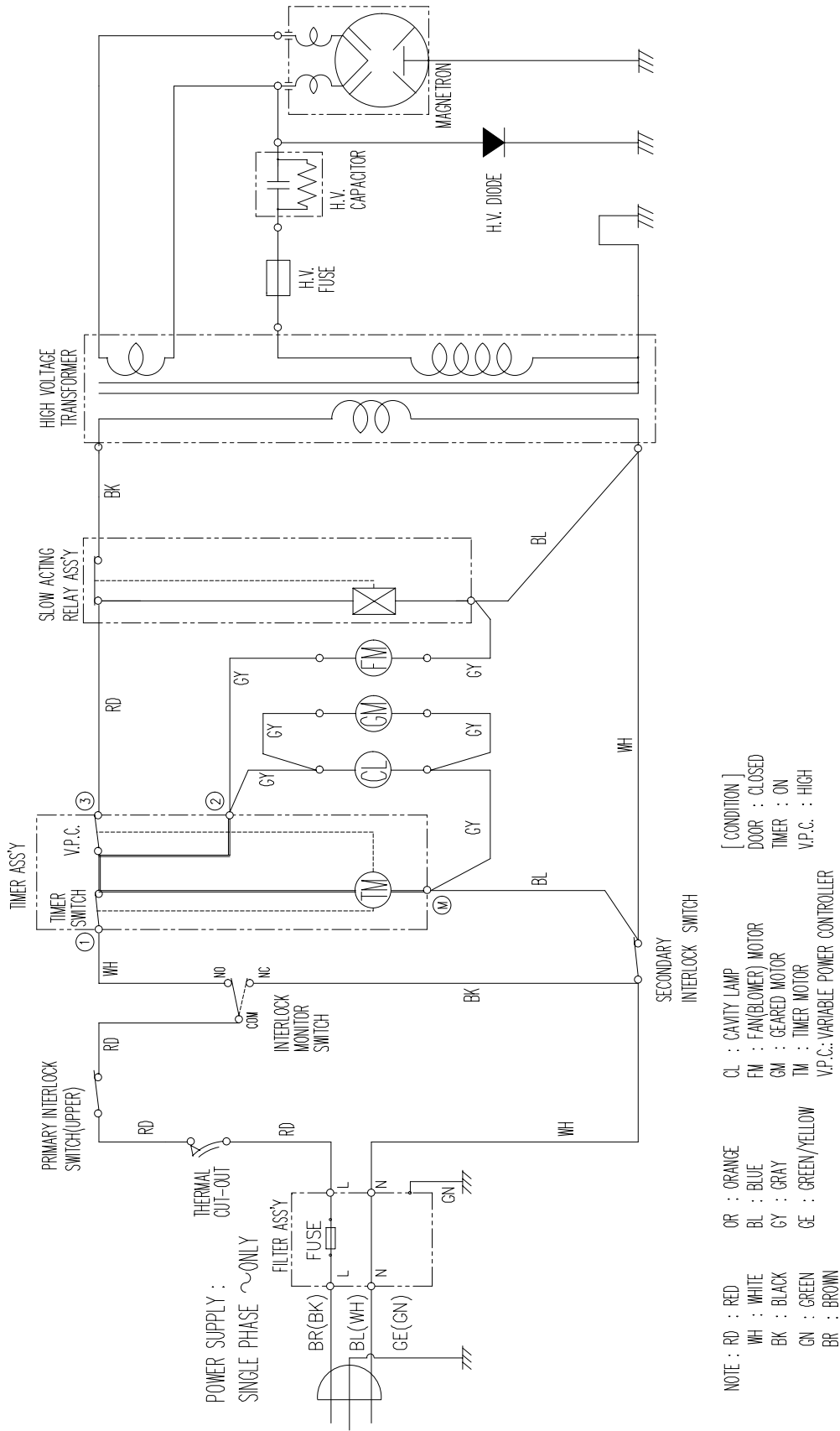

# EXPLODED VIEW AND PARTS LIST

## 1. DOOR ASSEMBLY

Refer to Disassembly and assembly.

## 2. CONTROL PANEL ASSEMBLY

Refer to Disassembly and assembly.

## 3. TOTAL ASSEMBLY

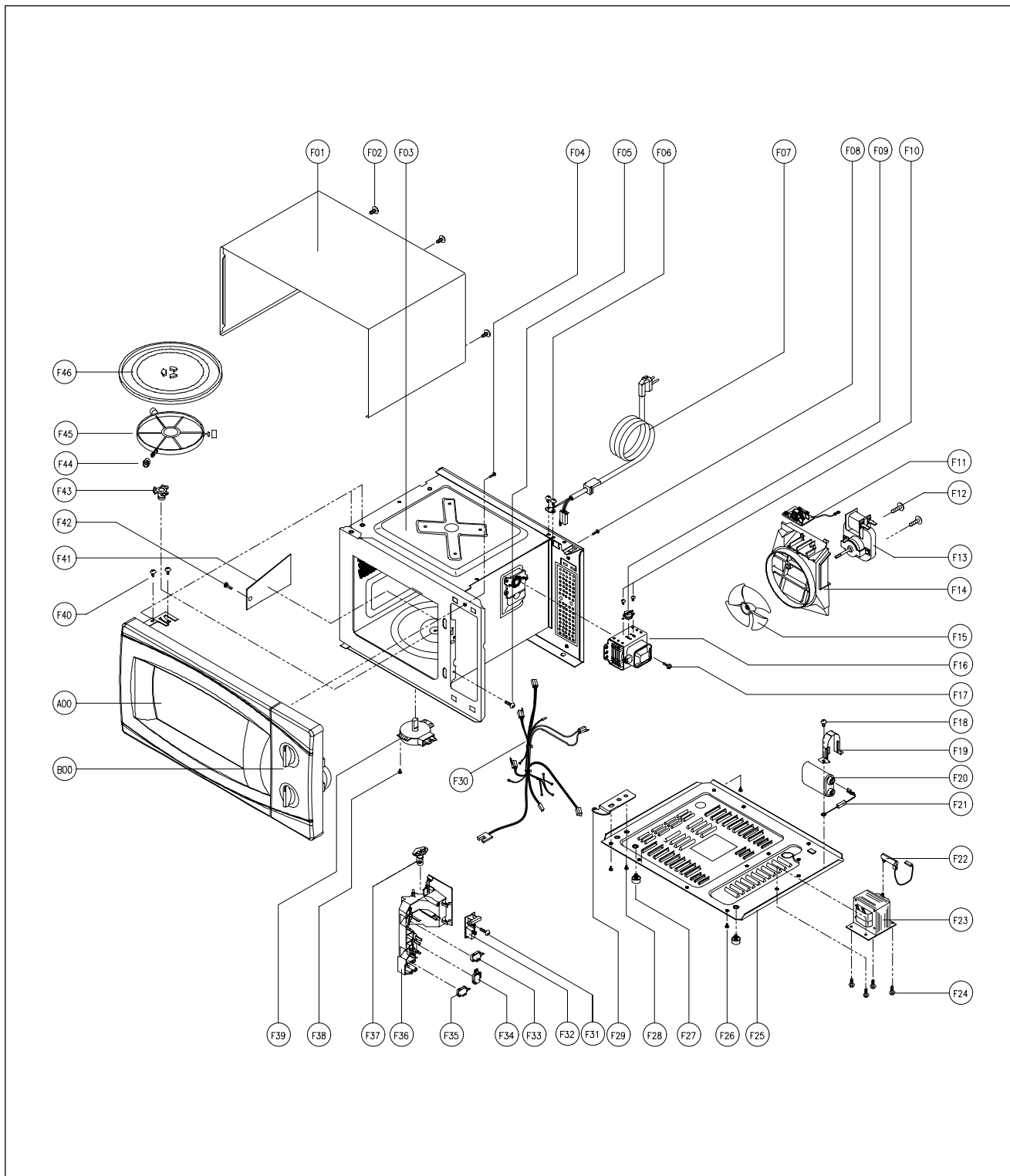

✓ **Caution** : In this Service Manual, some parts can be changed for improving, their performance without notice in the parts list. So, if you need the latest parts information, please refer to PPL(Parts Price List) in Service Information Center (<http://svc.dwe.co.kr>).

NO	PART CODE	PART NAME	DESCRIPTION	Q'TY
A00	3511707260	DOOR AS	KOR-41951S	1
B00	3516715560	CONTROL-PANEL AS	KOR-41951S	1
F01	3510806300	CABINET AS	KOR-41151S	1
F02	7112401011	SCREW TAPPING	T1 TRS 4*10 MFZN	3
F03	3516106600	CAVITY AS	KOR-41125J	1
F04	7122401211	SCREW TAPPING	T2S TRS 4X12 MFZN	1
F05	7122401211	SCREW TAPPING	T2S TRS 4X12 MFZN	1
F06	7112401011	SCREW TAPPING	T1 TRS 4*10 MFZN	2
F07	35113AEQ0D	CORD POWER AS	3X0.75 70X70 100-RTML	1
F08	7112401011	SCREW TAPPING	T1 TRS 4*10 MFZN	1
F09	3518903900	THERMOSTAT	OFF:160 ON:115 H #187	1
F10	7121300611	SCREW TAPPING	T2S PAN 3X6 MFZN	2
F11	3518607600	NOISE-FILTER	DWLF-M12 A 250V 10A	1
F12	7121402511	SCREW TAPPING	T2S PAN 4X25 MFZN	2
F13	3963512310	MOTOR SHADED POLE	230V 20W MW10CA-M02	1
F14	3512515400	GUIDE WIND	PP	1
F15	3511800300	FAN	PP+30%GLASS	1
F16	3518003710	MAGNETRON	2M218HFL 6CF	1
F17	3516004000	SPECIAL SCREW	T2 BOLT FLANGE 5X12 DACRO	1
F18	7122400811	SCREW TAPPING	T2S TRS 4*8 MFZN	1
F19	3513003200	HOLDER HV CAPACITOR	SECC T0.6	1
F20	3518301600	CAPACITOR HV	2100VAC 0.79UF #187	1
F21	3518400400	DIODE HV AS	HVR-1X-3AB 12KV #187	1
F22	3518701100	FUSE HV	5KV 0.55A HV-41A55-02	1
F23	3518107820	TRANS HV	R1S570(ES30)	1
F24	3516003700	SPECIAL SCREW	TT3 HEX 4X8 FLG MFZN	4
F25	3510310110	BASE	SBHG T0.6	1
F26	7112401011	SCREW TAPPING	T1 TRS 4*10 MFZN	4
F27	3512100900	FOOT	PP DASF-130	2
F28	7272400811	SCREW TAPTITE	TT3 TRS 4X8 MFZN	1
F29	3515202300	STOPPER HINGE *U AS	KOR-41125J	1
F30	3512711840	HARNESS MAIN	KOR-41151S (EC)	1
F31	7122401211	SCREW TAPPING	T2S TRS 4X12 MFZN	1
F32	3518570400	SWITCH S/A RELAY	DWSR-1	1
F33	4415A17352	SW MICRO	VP-533A-OF SPNO #187 200G	1
F34	4415A66910	SW MICRO	VP-531A-OF/SZM-V16-FA-61	1
F35	4415A17352	SW MICRO	VP-533A-OF SPNO #187 200G	1
F36	3513807301	LOCK	POM VE	1
F37	3513601600	LAMP	BL 240V 25W T25 C7A H187	1
F38	7121400611	SCREW TAPPING	T2S PAN 4X6 MFZN	1
F39	3966310100	MOTOR SYNCRO	220V 2.5W GM-16-24FD12	1
F40	7272400811	SCREW TAPTITE	TT3 TRS 4X8 MFZN	1
F41	3511403710	COVER WAVE GUIDE	MICA T0.5	1
F42	4414H50000	FIXTURE AS	KOG-36150S	1
F43	4418D10032	COUPLER	PPS	1
F44	3514701000	ROLLER	TEFLON	3
F45	3512512000	GUIDE ROLLER	PP	1
F46	3517203600	TRAY	BORO-SI GLASS	1



**DAEWOO**

**DAEWOO ELECTRONICS CORP.**  
686, AHYEON-DONG MAPO-GU SEOUL, KOREA  
C.P.O. BOX 8003 SEOUL, KOREA  
TELEX: DWELEC K28177-8  
CABLE: "DAEWOOELEC"

PRINTED DATE: Jul. 2004

S/M NO. : R41951S001