

Fisher® 667 Diaphragm Actuators Size 80 and 100

Contents

Introduction	1
Scope of Manual	1
Description	2
Specifications	2
Maximum Pressure Limitations	3
Installation	4
Actuator Mounting	4
Loading Connection	5
Adjustments	5
Size 80 Actuator Spring	6
Travel	5
Spring	6
Size 100 Actuator Spring	6
Maintenance	7
Size 80 Actuator Maintenance	8
Size 100 Actuator Maintenance	12
For Actuators without the Top-Loaded Option	15
For Actuators with the Top-Loaded Option	17
Size 80 Side-Mounted Handwheel	20
Size 80 Hydraulic Snubber	21
Size 100 Top-Mounted Handwheel (Adjustable Down Travel Stop)	21
Parts Ordering	22
Parts Kits	23
Parts List	23

Figure 1. Size 80 Fisher 667 Actuator



W1950

Introduction

Scope of Manual

This instruction manual provides information on installation, adjustment, maintenance, and parts ordering for the Fisher 667 actuator in sizes 80 and 100 (figure 1). Refer to separate instruction manuals for information about other equipment and accessories used with these actuators.



Do not install, operate, or maintain 667 actuators without being fully trained and qualified in valve, actuator, and accessory installation, operation, and maintenance. To avoid personal injury or property damage, it is important to carefully read, understand, and follow all the contents of this manual, including all safety cautions and warnings. If you have any questions about these instructions, contact your Emerson Process Management sales office before proceeding.

Table 1. Specifications

SPECIFICATION		ACTUATOR SIZE		
		80		100
Nominal Effective Diaphragm Area	cm ²	1761		2902
	inch ²	273		450
Yoke Boss Diameters	mm	127		127 178
	inch	5		5H ⁽¹⁾ 7
Acceptable Valve Stem Diameters	mm	25.4 or 31.8		31.8 50.8
	inch	1 or 1-1/4		1-1/4 2
Maximum Allowable Output Thrust		Standard Cast Iron Construction	All Steel Construction	
	N	62942	88075	200170
	lb	14150	19800	45000
Maximum Travel	mm	76		102
	inch	3		4
Material Temperature Capabilities	°C	-40 to 82		
	°F	-40 to 180		
Pressure Connections		1/4 NPT internal		
Approximate Weights Without Handwheel	kg	284		544
	lb	626		1200

1. Heavy actuator-to-bonnet bolting.

Description

The 667 actuator is a reverse-acting actuator. Reverse-acting actuators use air action to lift the diaphragm (away from the valve), and spring action opposes the diaphragm action (see figure 2). The actuator position changes in response to varying controlled air pressure to the diaphragm. If air pressure is reduced or lost from the actuator diaphragm, spring action will extend the actuator stem. The actuator is often used with control valves using a pneumatic positioner for air pressure control, and where fail action will fully open or close the control valve as the actuator stem extends.

Also, the actuator can be furnished with either a side-mounted (size 80 only) handwheel assembly or a top-mounted handwheel (adjustable up travel stop) (size 100 only). The size 80 side-mounted handwheel is normally used as an auxiliary manual actuator. The size 100 top-mounted handwheel is used as either a travel stop or an auxiliary manual actuator.

The actuator can be furnished with a top-loading capability. A top-loaded actuator allows air pressure to be applied to the top of the diaphragm, aiding the spring to extend the actuator stem. This air pressure increases valve seat load on valve applications where additional seat-loading is necessary.

Specifications

Refer to table 1 for Specifications of the 667 actuator. See the actuator nameplate for information about a specific actuator.

Figure 2. Schematic Representation of Fisher 667 Actuator

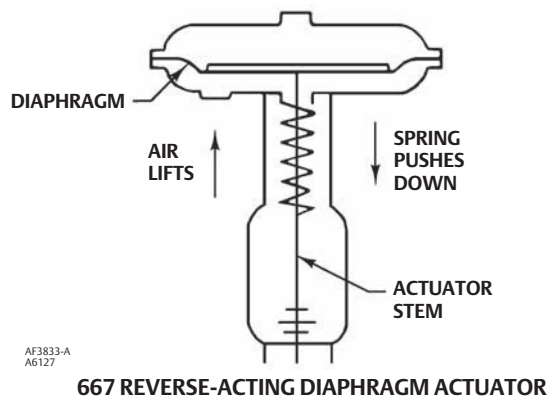

Table 2. Maximum Pressure Limitations

PRESSURE LIMITATIONS		ACTUATOR SIZE		
		80		100
		Standard Cast Iron Construction	All Steel Construction	
Maximum Casing Pressure for Actuator Sizing	bar	3.4	4.9	6.9
	psig	50	70	100
Maximum Excess Diaphragm Pressure	bar	1.4	1.4	1.7
	psig	20	20	25
Maximum Diaphragm Casing Pressure		Upper bench set plus Maximum Excess Diaphragm Pressure or 4.1 bar (60 psig), whichever is less.	Upper bench set plus Maximum Excess Diaphragm Pressure or 5.5 bar (80 psig), whichever is less.	Upper bench set plus Maximum Excess Diaphragm Pressure or 7.9 bar (115 psig), whichever is less.

Maximum Pressure Limitations

⚠ WARNING

To avoid personal injury or parts damage, do not exceed the Maximum Pressures listed in table 2. Exceeding any of the maximum pressures can result in uncontrolled movement of parts, damage to actuator parts and the control valve, and loss of control of the process. Use pressure-limiting or pressure-relieving devices to prevent casing pressure from exceeding these limits.

The casing and diaphragm of 667 actuators are pressure operated. This air pressure provides force to compress the spring and stroke the actuator. The following explanations describe the maximum pressure limits for 667 actuators. Refer to the nameplate, warning tag, and table 2 for maximum values.

- **Maximum Casing Pressure for Actuator Sizing:** This is the maximum pressure that can be applied to provide full travel of the actuator. If this stroking pressure is exceeded before the upper diaphragm plate contacts the travel stop, damage to the stem or other parts might result. The Maximum Diaphragm Casing Pressure for a specific actuator construction may be less than the Maximum Casing Pressure for Actuator Sizing. See table 2.
- **Maximum Excess Diaphragm Pressure:** This is the additional pressure that may be added when the actuator is at full travel. If the Maximum Excess Diaphragm Pressure is exceeded once the actuator has reached full travel, damage to the diaphragm or diaphragm casing might result.

Because the actuator has traveled its specified travel, and the diaphragm head is physically stopped from movement, the force from any additional air pressure is transmitted to the diaphragm and diaphragm casings. The amount of air pressure that can be added once the actuator has traveled to the stops is limited by the resultant adverse effects that may occur. Exceeding this limiting factor could result in leakage or casing fatigue due to the deformation of the upper diaphragm casing.

- **Maximum Diaphragm Casing Pressure:** If the Maximum Diaphragm Casing Pressure is exceeded, damage to the diaphragm, diaphragm casing, or actuator might result. For some actuator constructions, the maximum Diaphragm Casing Pressure is the sum of the upper bench set, noted on the nameplate, added to the Maximum Excess Diaphragm Pressure. For other actuator sizes, the value is lower, see table 2.

⚠ WARNING

To avoid personal injury or parts damage, do not exceed the Maximum Diaphragm Casing Pressure listed in table 2. The Maximum Diaphragm Casing Pressure must not produce a force on the actuator stem greater than the maximum allowable actuator output thrust or the maximum allowable stem load.

Installation

⚠ WARNING

Always wear protective gloves, clothing, and eyewear when performing any installation operations to avoid personal injury.

Check with your process or safety engineer for any additional measures that must be taken to protect against process media.

If installing into an existing application, also refer to the WARNING at the beginning of the Maintenance section in this instruction manual.

When an actuator and valve are shipped together, the actuator is normally mounted on the valve. Follow the valve instructions when installing the control valve in the pipeline. If the actuator is shipped separately or if it is necessary to mount the actuator on the valve, perform the following Actuator Mounting procedures.

For information on mounting valve positioners, refer to the appropriate valve positioner instruction manual.

Actuator Mounting

1. Mount the actuator on the valve bonnet. Insert the cap screws and tighten the hex nuts, securing the actuator to the bonnet.
2. Screw the valve stem jam nuts (key 69, figures 6 and 7) all the way onto the valve stem threads.
3. Connect an air supply to the lower diaphragm casing connection.
4. For push-down-to-close valves, be sure the valve plug is on its seat. Reduce loading pressure to ensure that the actuator stem is fully extended. Apply slight loading pressure to retract the stem approximately 3.2 mm (1/8-inch).
5. For push-down-to-open valves, apply pressure to ensure that the actuator stem is fully retracted. Be sure the valve plug is on its seat. On large valve sizes, this may require the use of a pry bar inserted through the valve body line

opening. If the valve is installed in a pipeline, the bottom flange (if one is used) can be removed and the valve plug pushed to the seat from the bottom opening. Reduce actuator loading pressure to extend the stem approximately 3.2 mm (1/8-inch).

CAUTION

Incomplete engagement of either the valve stem or actuator stem in the stem connector can result in stripped threads or improper operation. Be sure that the length of each stem clamped in the stem connector is equal to or greater than the diameter of that stem.

6. Clamp the actuator and valve plug stems between the two stem connector halves (key 31, figures 6 and 7). Insert and tighten the stem connector cap screws.
7. Thread the stem locknuts against the stem connector.
8. Align the travel indicator scale (key 32, figures 6 and 7) to show valve position.

⚠ WARNING

To avoid personal injury due to the sudden, uncontrolled movement of parts, do not loosen the cap screws when the stem connector has spring or loading pressure force applied to it.

Loading Connection

Key number locations are shown in figures 6 and 7, unless otherwise directed.

1. Connect the loading pressure piping to the connection in the size 80 spring case adaptor (key 89) or in the size 100 lower diaphragm casing (key 67).

For top-loaded actuators

1. For size 80, remove the the pipe bushing (key 78), and connect the loading pressure piping in its place. For size 100, remove the hex bushing (key 62) from the upper casing (key 1), and connect the top loading pressure piping in its place.
2. Remove the 1/4-inch bushing (key 92, figure 6; key 62, figure 7) to increase connection size, if necessary. The connection can be made with either piping or tubing.
3. Keep the length of tubing or piping as short as possible to avoid transmission lag in the control signal. If an accessory (such as a volume booster or valve positioner) is used, be sure that the accessory is properly connected to the actuator. Refer to the positioner instruction manual as necessary.
4. Cycle the actuator several times to check that the valve stem travel is correct and that the travel occurs when the correct pressure range is applied to the diaphragm.
5. If valve stem travel is incorrect, refer to the Travel procedure in the Adjustments section.
6. If the spring pressure range is incorrect, refer to the Spring procedure in the Adjustments section.

Adjustments

Travel

Make travel adjustments when the motion observed during actuator travel is different from the travel stamped on the actuator nameplate. If the Actuator Mounting procedure was followed correctly, this adjustment should not be necessary.

When adjusting travel of a direct-acting valve, put a slight pressure on the actuator diaphragm. This moves the valve plug off the seat, reducing the chance of damaging the valve plug or seat during adjustments.

1. Back the stem jam nuts (key 69, figures 6 and 7) away from the stem connector (key 31, figures 6 and 7), and slightly loosen the stem connector cap screws.

CAUTION

Do not use wrenches or other tools directly on the valve stem. Damage to the stem surface and subsequent damage to the valve packing may result.

2. Tighten the locknuts together, using a wrench, then screw the valve stem either into the stem connector to lengthen travel or out of the stem connector to shorten travel.
3. Cycle the actuator to check for the specified travel. If actual travel is not equal to the specified travel, adjust and check travel until correct. Tighten the stem connector cap screws when correct travel is obtained.
4. Raise the travel indicator disk by threading the stem locknuts against the stem connector.

Spring

Make spring adjustments when the loading pressure range applied to achieve specified travel is not equal to the pressure range stamped on the actuator nameplate. Refer to the Bench Set pressure range on the nameplate when the valve contains no pressure and the packing is loosely inserted in the bonnet. Refer to the Maximum Allowable Supply pressure on the nameplate when the valve is controlling the specified pressure drop, and the packing is tightened to stop leaks around the stem.

Monitor loading pressure carefully when making adjustments. Do not exceed the pressure specifications of either the loading regulator or the actuator casings.

Each actuator spring has a fixed pressure span. Changing the spring compression shifts the span up or down to make valve travel coincide with the loading pressure range.

Size 80 Actuator Spring

Note

Before turning the spring adjuster on size 80 actuators, assemble the stem connector around the actuator stem and the anti-rotating lug on the yoke. Mark the actuator stem as a visual reference to verify that stem rotation does not occur. Remove the stem connector before rechecking the bench set.

Remove the cover band (key 87, figure 6), insert a rod of approximately 12.7 mm (1/2 inch) diameter into a hole in the spring adjuster (key 74, figure 6), and rotate the spring adjuster with the rod. Rotating the adjuster from left to right will increase the loading pressure required to start actuator stem travel; opposite rotation will decrease the pressure required to start travel.

Size 100 Actuator Spring

CAUTION

The actuator must be in the vertical position when adjusting the spring to avoid damage to the thrust bearing (key 86, figure 7) and to properly position the spacers required for adjustment.

Remove the shroud plate (key 65, figure 7), and loosen the jam nut (key 26, figure 7).

For small spring forces, adjustments can be made by rotating the adjusting nut (key 25, figure 7). Counterclockwise rotation (when viewed from the diaphragm casings) of the adjusting nut will increase the loading pressure required to start actuator stem travel, and clockwise rotation will decrease the pressure required to start travel. Tighten the jam nut when adjustment is complete.

For high spring forces, it is necessary to use spacers between the bottom of the yoke and the spring seat to isolate spring force from the adjusting nut.

⚠ WARNING

To avoid personal injury from the compressed actuator spring snapping back to its original length, make and use the spacers by following the instructions in the steps below.

1. It is recommended that three spacers be made of three-inch schedule 80 pipe cut to the appropriate length specified in step 2. If other than the recommended material is to be used, be certain that the spacers are capable of withstanding the spring force involved. The spacers must also be of equal length with ends cut squarely.
2. Measure dimension B as shown in figure 3. Cut the length of the spacers as follows:
 - a. If it is desired to decrease spring compression, make the spacers approximately 4.8 mm (3/16-inch) longer than dimension B.
 - b. If it is desired to increase spring compression, make the spacers approximately 4.8 mm (3/16-inch) shorter than either dimension B plus the amount of adjustment required or dimension B plus valve travel, whichever is less.
3. Whenever the total amount of adjustment required is greater than valve travel, the adjustment must be made in two or more steps, and the amount of adjustment taken in each step must be less than valve travel.
4. Pressure the actuator to attain full travel. Cautiously insert the spacers at equal intervals around the spring seat (key 19, figure 7). Spacers must be seated squarely, or they may slip out of position. Keeping hands and tools away from the spring and spring seat, slowly decrease loading pressure until the spring force holds the spacers firmly between the spring seat and the bottom of the yoke.
5. Loosen the jam nut. The adjusting nut can now be rotated counterclockwise (when viewed from the diaphragm casings) to increase the loading pressure required to start actuator stem travel or clockwise to decrease the pressure required to start travel.
6. Pressure the actuator to move the spring seat away from the spacers, and carefully remove the spacers.
7. Slowly reduce the air pressure to the actuator. Make sure that the thrust bearing (key 86) is correctly seated in the spring seat before contact with the adjustment nut (key 25) is made.
8. If the total adjustment required was greater than valve travel, repeat the procedure. It will be necessary to make new spacers using the new dimension B and the remaining adjustment required or valve travel, whichever is less. Tighten the jam nut when adjustment is complete.

Maintenance

⚠ WARNING

Avoid personal injury or property damage from sudden release of process pressure or bursting of parts. Before performing any maintenance operations:

- Do not remove the actuator from the valve while the valve is still pressurized.
- Always wear protective gloves, clothing, and eyewear when performing any maintenance operations to avoid personal injury.
- Disconnect any operating lines providing air pressure, electric power, or a control signal to the actuator. Be sure the actuator cannot suddenly open or close the valve.
- Use bypass valves or completely shut off the process to isolate the valve from process pressure. Relieve process pressure from both sides of the valve. Drain the process media from both sides of the valve.
- Vent the power actuator loading pressure and relieve any actuator spring precompression.
- Use lock-out procedures to be sure that the above measures stay in effect while you work on the equipment.
- The valve packing box may contain process fluids that are pressurized, *even when the valve has been removed from the pipeline*. Process fluids may spray out under pressure when removing the packing hardware or packing rings, or when loosening the packing box pipe plug.
- Check with your process or safety engineer for any additional measures that must be taken to protect against process media.

Figure 3. Dimension B for Spring Adjustment

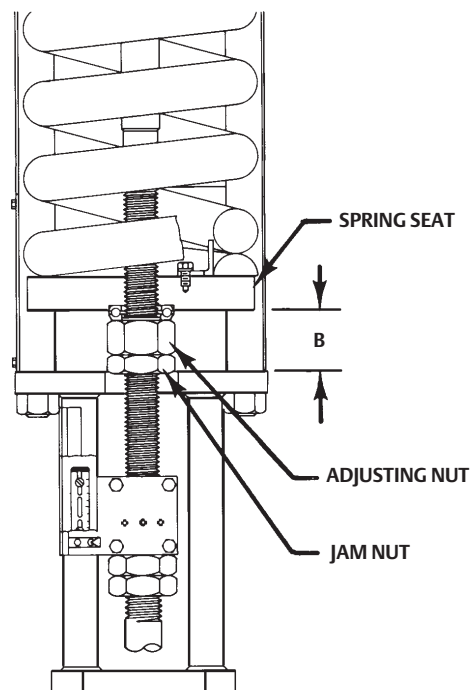

Size 80 Actuator Maintenance

For size 80 actuators, refer to figure 4 for part names and locations. Key number locations for size 80 actuators are shown in figure 6.

Disassembly

1. Isolate the control valve from the line pressure, release pressure from both sides of the valve, and drain the process media from both sides of the valve. Shut off all pressure lines to the power actuator, release all pressure from the

actuator. Use lock-out procedures to be sure that the above measures stay in effect while you work on the equipment.

2. Remove the tubing or piping from the connection in the top of the spring case adaptor (key 89).
3. If the actuator has a handwheel, rotate the handwheel to relieve all spring compression.
4. Remove the cover band (key 87). Insert a steel rod of approximately 12.7 mm (1/2-inch) diameter into a hole in the spring adjuster (key 74), and rotate the spring adjuster from right to left until spring compression is relieved.

⚠ WARNING

To avoid personal injury due to the sudden, uncontrolled movement of parts, do not loosen the cap screws on the stem connector (key 31) when spring force is applied.

5. If necessary, the entire actuator assembly may be removed from the valve by unscrewing the cap screws from the stem connector (key 31) and removing actuator-to-bonnet bolting.
6. Unscrew the diaphragm casing cap screws and nuts (keys 13 and 14), and lift off the upper diaphragm casing (key 1).
7. Unscrew the diaphragm cap screw (key 12), remove the spacer, upper diaphragm plate, diaphragm, and lower diaphragm plate (keys 2, 4, 3, and 71).

Note

Standard and top-loaded constructions use the same key numbers for parts. The parts look different, but they use the same assembly and disassembly sequence. See figure 4, Size 80 Actuator Construction for location of parts.

8. Unscrew the cap screws (key 30), and remove the lower diaphragm casing (key 64).
9. For actuators without a snubber:
 - a. Unscrew the spring case adaptor cap screws and nuts (keys 90 and 91), and remove the adaptor (key 89) from the actuator.
 - b. Remove the snap ring and seal bushings (keys 72 and 7). Inspect, and if necessary, obtain a replacement seal bushing (key 7). Replace the seal bushing O-rings (keys 8 and 9) as required. Lubricate with lithium grease (key 237) lubricant.
 - c. Remove the actuator spring (key 18). Unscrew the cap screws from the stem connector (key 31), and remove the stem connector. Remove the stem (key 144) and attached spring adjuster, thrust bearing, and spring seat (keys 74, 86, and 19).
10. For actuators with a snubber (see figure 8):

⚠ WARNING

To avoid personal injury due to the sudden, uncontrolled movement of parts, ensure the actuator spring is not under compression before removing the travel stop.

- a. Remove the travel stop (key 84). Be certain there is not compression in the actuator spring (key 18). If the actuator was removed from the valve, secure the stem connector (key 31) to the actuator stem (key 144) to prevent the stem from turning while unscrewing the stem and piston assembly (key 23).

b. Using a wrench on the wrench flats near the top of the stem and piston assembly, unscrew the stem and piston assembly from the actuator stem.

c. Unscrew the cap screws (key 106), and remove the cylinder (key 93) and attached parts.

11. To disassemble snubber:

a. Remove the retaining rings, cylinder heads, and stem and piston assembly (keys 95, 94, and 23).

b. Replace packing and O-rings (keys 118, 119, 96, 107, and 120).

c. Unscrew the spring case adaptor cap screws and nuts (keys 90 and 91), and remove the adaptor (key 89) from the actuator.

12. Remove the actuator spring and spring seat (keys 18 and 19).

13. Unscrew the cap screws and nuts (keys 88 and 91), and remove the spring case (key 85).

Note

In figure 8, the cap screws (key 88) on units with side-mounted handwheels do not use hex nuts (key 91).

14. Remove the spring adjustor (key 74) and the attached thrust bearing (key 86).

15. Remove the cap screws (key 252), yoke bushing retainer (key 251), 2 halves of the split yoke bushing (key 249), and yoke bushing holder (key 250).

16. Refer to the size 80 actuator assembly procedures. Carefully clean and inspect all parts, and obtain any replacement parts required for reassembly.

Assembly

See figure 4, Size 80 Actuator Construction for location of parts.

1. Coat the threads of the stem (key 144) with lithium grease lubricant (key 237). Install the spring adjustor (key 74) and thrust bearing. Pack the bearing (key 86) with lithium grease lubricant.

2. Mount the spring case (key 85) to the yoke (key 73) using cap screws and hex nuts (keys 88 and 91).

Note

Units with a side-mounted handwheel do not use hex nuts (key 91).

3. Install the spring adjustor, thrust bearing, and spring seat (keys 74, 86 and 19) onto the actuator stem (key 144). Slide the stem into the spring case (key 85).

4. Align the spring seat (key 19) on the spring adjustor (key 74), and slide the actuator spring (key 18) squarely onto the spring seat.

5. Mount the spring case adaptor (key 89) to the spring case (key 85) using cap screws and hex nuts (keys 90 and 91).

6. For actuators with a snubber (see figure 8), install the cylinder (key 93) and attached parts with cap screws (key 106). Slide the stem and piston assembly (key 23) into the cylinder and thread onto the actuator stem (key 144). Attach the travel stop (key 84), if one is used, to the stem and piston assembly.

Figure 4. Size 80 Actuator Construction

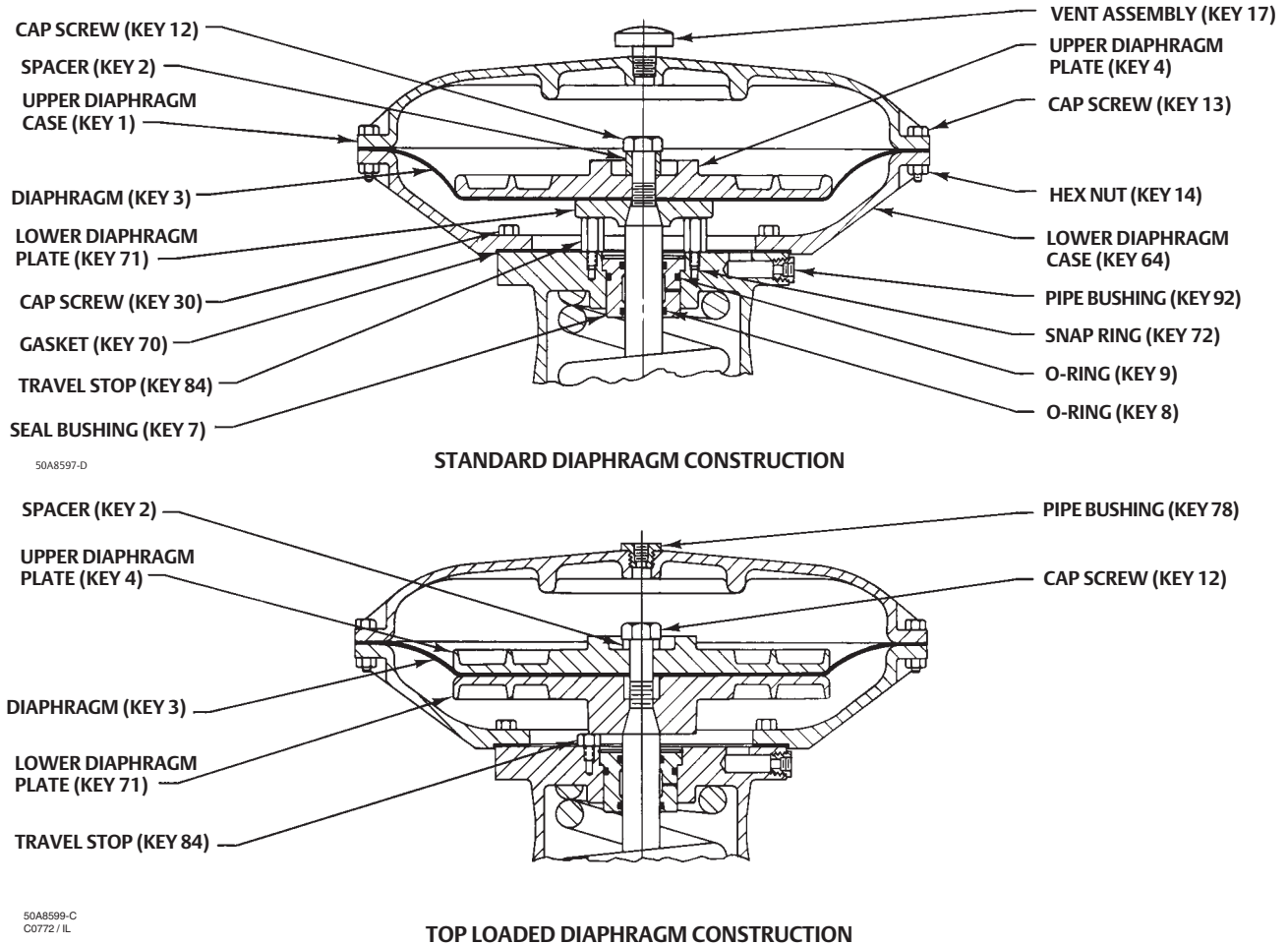

7. For actuators without a snubber, install the seal bushing (key 7) into the spring case adaptor (key 89) followed by the snap ring (key 72). Replace the seal bushing O-rings (keys 8 and 9) as required.
8. Coat the gasket (key 70) with lithium grease lubricant (key 237). Position the lower diaphragm casing (key 64) on the spring case adaptor, and secure with cap screws (key 30).
9. Mount the lower diaphragm plate, diaphragm, upper diaphragm plate, and, if used, spacer (keys 71, 3, 4, and 2) on the actuator stem (key 144), and secure using the cap screw (key 12). Coat the cap screw threads with lithium grease (key 237). Tighten the cap screw (key 12) to 544 N•m (400 lbf•ft).

Note

Standard and top-loaded constructions use the same key numbers for parts. The parts look different, but they use the same assembly and disassembly sequence. See figure 4, Size 80 Actuator Construction.

10. Position the upper diaphragm casing (key 1) on the diaphragm (key 3), and align the holes.

Note

When you replace actuator diaphragms in the field, take care to ensure the diaphragm casing cap screws are tightened to the proper load to prevent leakage, but do not crush the material. Perform the following tightening sequence with a manual torque wrench for size 80 and 100 actuators.

CAUTION

Do not use lubricant on these cap screws and nuts. Fasteners must be clean and dry.

Overtightening the diaphragm casing cap screws and nuts can damage the diaphragm. Do not exceed the following maximum torque values for the appropriate diaphragm material: EPDM/Meta-Aramid: 95 N•m (70 lbf•ft); Nitrile, Silicone, FKM (fluorocarbon) / Meta-Aramid: 68 N•m (50 lbf•ft).

11. Insert the cap screws (key 13) into the diaphragm casing, and tighten the hex nuts (key 23) in the following manner. The first four hex nuts tightened should be diametrically opposed and 90 degrees apart. Tighten these four hex nuts to the initial torque value found in table 3 for the diaphragm material being used.
12. Tighten the remaining hex nuts in a clockwise, crisscross pattern to the initial torque value found in table 3 for the diaphragm material being used.
13. Repeat this procedure by tightening four hex nuts, diametrically opposed and 90 degrees apart, to the final torque value that is specified in table 3 for the diaphragm material being used.
14. Tighten the remaining hex nuts in a clockwise, crisscross pattern to the final torque value that is specified in table 3 for the diaphragm material being used.
15. After the last hex nut is tightened, complete another tightening sequence. Tighten in a circular pattern around the bolt circle to the final torque value that is specified in table 3 for the diaphragm material being used.
16. Once completed, no more tightening is recommended.
17. For size 80 actuators without a manual operator, slide the following parts over the bottom of the stem; yoke bushing holder (key 250), two split yoke bushings (key 249), and yoke bushing retainer (key 251). Secure into place with 4 cap screws (key 252). Before inserting the bushing halves, lightly coat with lithium grease (key 237) lubricant.
18. Mount the actuator on the valve in accordance with the procedures in the Installation section.

Size 100 Actuator Maintenance

For size 100 actuators, refer to figure 5 for part names and locations. Key number locations for Size 100 actuators are shown in figure 7.

Table 3. Size 80 Casing Cap Screw Torque Values

DIAPHRAGM MATERIAL	INITIAL TORQUE		FINAL TORQUE	
	N•m (lbf•ft)		N•m (lbf•ft)	
EPDM / Meta-Aramid	41 (30)		82 ± 13 (60 ± 10)	
Nitrile, Silicone, FKM/Meta-Aramid	34 (25)		68 (50)	

⚠ WARNING

Avoid personal injury or property damage from sudden release of process pressure or bursting of parts. Before performing any maintenance operations:

- Do not remove the actuator from the valve while the valve is still pressurized.
 - Always wear protective gloves, clothing, and eyewear when performing any maintenance operations to avoid personal injury.
 - Disconnect any operating lines providing air pressure, electric power, or a control signal to the actuator. Be sure the actuator cannot suddenly open or close the valve.
 - Use bypass valves or completely shut off the process to isolate the valve from process pressure. Relieve process pressure from both sides of the valve. Drain the process media from both sides of the valve.
 - Vent the power actuator loading pressure and relieve any actuator spring precompression.
 - Use lock-out procedures to be sure that the above measures stay in effect while you work on the equipment.
 - The valve packing box may contain process fluids that are pressurized, *even when the valve has been removed from the pipeline*. Process fluids may spray out under pressure when removing the packing hardware or packing rings, or when loosening the packing box pipe plug.
 - Check with your process or safety engineer for any additional measures that must be taken to protect against process media.
-

1. Isolate the control valve from the line pressure, release pressure from both sides of the valve, and drain the process media from both sides of the valve. If using a power actuator, also shut off all pressure lines to the power actuator, release all air pressure from the actuator. Use lock-out procedures to be sure that the above measures stay in effect while you work on the equipment.
2. Remove the shroud plate (key 65) by removing the cap head screws (key 66).
 - a. For small spring force, loosen the jam nut (key 26), and rotate the adjusting nut (key 25) until spring compression is relieved.
 - b. For high spring force:

Note

To relieve spring compression when high spring forces exist, refer to the Spring section, and follow the instructions given for size 100 actuators with high spring force. These instructions outline the procedure required to decrease high spring compression.

- Loosen the jam nut (key 26), and rotate the adjusting nut (key 25) until spring compression is relieved.
3. Remove the pressure tubing or piping from the top of the diaphragm casing.
 4. For actuators with a top-mounted handwheel (see figure 9), rotate the handwheel (key 58) clockwise as far as it will go, unscrew the cap screws (key 54), and remove the gear case cover (key 53). Remove the travel stop cap screw, if one is used, from the actuator stem extension (key 36), and unscrew the hex nuts (key 47). Unscrew the cap screws that attach the gear case assembly (key 41) to the actuator, and remove the gear case assembly.
 5. If necessary, remove the actuator from the valve by separating the stem connector (key 31) and removing the actuator-to-bonnet bolting. Separate the stem connector by loosening the stem locknuts (key 69) and unscrewing the four cap screws.

Note

If the actuator has been removed from the valve, ensure that it is in the vertical position. Then, block the actuator stem (key 144) to support the weight of the actuator stem, spring seat and spring (keys 144, 19, and 18). This will facilitate removal of the nut (key 24) or actuator stem connector (key 31, figure 8).

Figure 5. Size 100 Actuator Construction

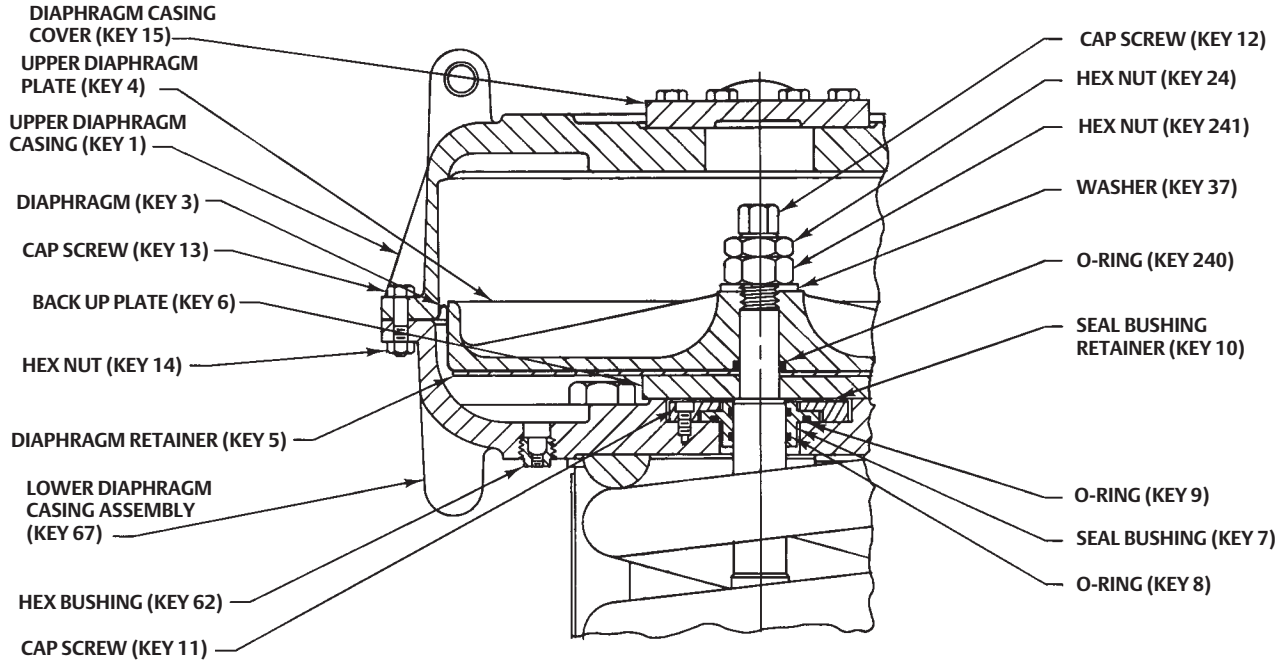

50A2623-F

STANDARD DIAPHRAGM CONSTRUCTION

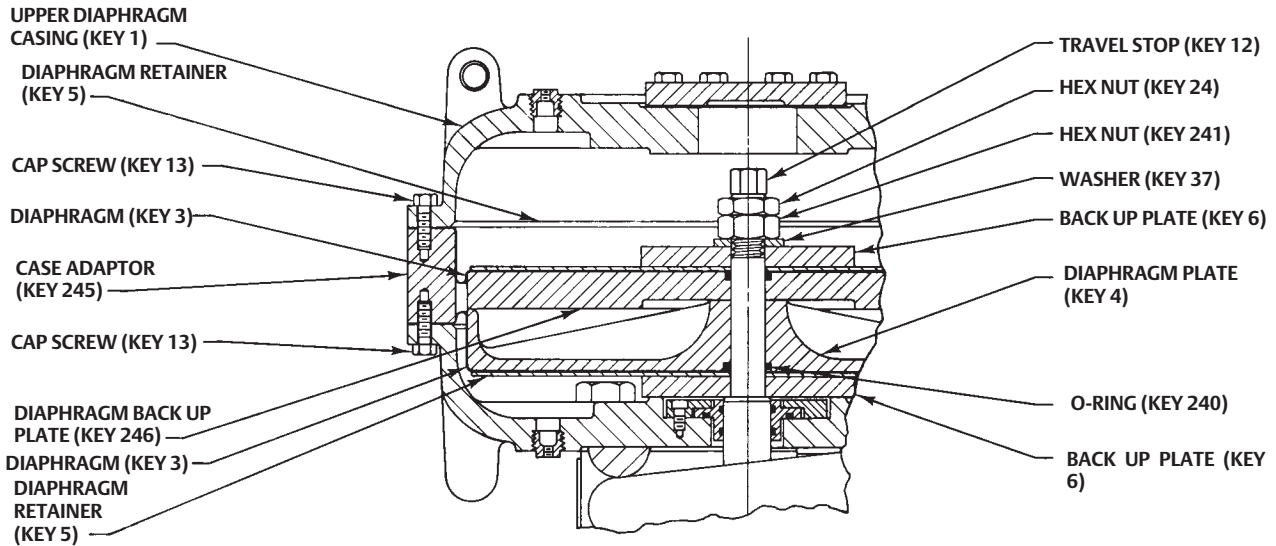

56A9820-8
C0773-1

TOP LOADED DIAPHRAGM CONSTRUCTION

For Actuators Without the Top-Loaded Option

Disassembly

Part names and locations are shown in figure 5. Size 100 actuator key number locations are shown in figure 7.

1. Unscrew the diaphragm casing cap screws and nuts (keys 13 and 14) and remove the upper diaphragm casing.
2. For actuators without a top-mounted handwheel, unscrew and remove the travel stop cap screw (key 12), if one is used, and the hex nut (key 24).
3. For actuators with a top-mounted handwheel (see figure 9), remove the hex nut, actuator stem extension, and actuator stem connector (keys 28, 36, and 42).
4. Remove the washer, upper diaphragm plate, diaphragm, diaphragm retainer, and backup plate (keys 37, 4, 3, 5 and 6).
5. Unscrew the six cap screws (key 11), and remove the seal bushing retainer (key 10). Remove the seal bushing (key 7).

⚠ WARNING

To avoid personal injury and property damage from the sudden release of spring load, be sure that all spring load is removed from the actuator lower diaphragm casing.

6. Unscrew the four hex nuts that secure the lower diaphragm casing to the yoke assembly (key 67), and remove the lower diaphragm casing. Replace the yoke assembly O-rings (key 70) as necessary.
7. The actuator spring (key 18) and stem (key 144) can now be removed if necessary. Be sure to disconnect the stem connector (key 31) before removing the stem.
8. Refer to the following Assembly procedures. Carefully clean and inspect all parts, or obtain replacement parts required for reassembly.

Assembly

1. If the actuator stem (key 144, figure 7) was removed, lubricate the threads on the stem with lithium grease lubricant (key 237).
2. On the actuator stem, assemble the hex nuts, thrust bearing, and spring seat (keys 26, 25, 86, and 19) to the stem. Be certain that the thrust bearing race with the larger inside diameter faces the spring seat. Rotate the adjusting nut (key 25) to position the spring seat 305 mm (12 inches) from the end of the stem.
3. Install the actuator stem assembly into the yoke assembly (key 67). Place a support under the stem to position the lower end of the stem 254 mm (10 inches) above the bottom surface of the actuator (actuator-to-bonnet joint).

Note

When installing lower diaphragm casing, install the O-rings (key 70) into the grooves found in the lower diaphragm casing before placing the casing on the yoke assembly. If the spring interferes with installation of the lower diaphragm casing, reposition the spring by rotating the adjusting nut (key 25).

4. Install the lower diaphragm casing, and secure it by tightening the four hex nuts.
5. Lubricate the seal bushing O-rings (keys 8 and 9) and the seal bushing (key 7) with lithium grease lubricant. Install the seal bushing O-rings, seal bushing, and seal bushing retainer (keys 8, 9, 7 and 10) and secure with the cap screws (key 11).

6. Install the diaphragm backup plate, diaphragm retainer, diaphragm, upper diaphragm plate, and washer (keys 6, 5, 3, 4, and 37) on the actuator stem (key 144).

CAUTION

Install the diaphragm with the fabric side facing away from the spring. Smooth the edge of the diaphragm to avoid wrinkling and be careful that the diaphragm fold does not get pinched when the upper diaphragm casing (key 1) is installed.

CAUTION

If the diaphragm (key 3) is installed so air pressure is applied to the fabric side, it will immediately delaminate the sealing surface (smooth surface) from the fabric. The delamination can cause immediate failure of the diaphragm's ability to retain pressure.

7. For actuators with a top-mounted handwheel, screw the actuator stem extension (key 36, figure 9) as far as it will go into the actuator stem connector (key 42, figure 9) before tightening the hex nut (key 28, figure 9).
8. For actuators without a top-mounted handwheel, install the hex nut (key 241) and tighten, install the jam nut (key 24) and tighten so that it locks the hex nut key 24 in place. Install the travel stop (key 12).
9. Position the upper diaphragm casing (key 1) on the diaphragm (key 3) and align the holes.

Note

When you replace actuator diaphragms in the field, take care to ensure the diaphragm casing cap screws are tightened to the proper load to prevent leakage, but not crush the material. Perform the following tightening sequence with a manual torque wrench for size 80 and 100 actuators.

CAUTION

Do not use lubricant on these cap screws and nuts. Fasteners must be clean and dry.

Overtightening the diaphragm casing cap screws and nuts can damage the diaphragm. Do not exceed 68 N•m (50 lbf•ft) torque.

10. Insert the cap screws (key 13) into the upper diaphragm casing, and tighten the hex nuts (key 14) in the following manner. The first four hex nuts tightened should be diametrically opposed and 90 degrees apart. Tighten these four hex nuts to 34 N•m (25 lbf•ft).
11. Tighten the remaining hex nuts in a clockwise, crisscross pattern to 34 N•m (25 lbf•ft).
12. Repeat this procedure by tightening the four hex nuts, diametrically opposed and 90 degrees apart, to a torque of 68 N•m (50 lbf•ft).
13. Tighten the remaining hex nuts in a clockwise, crisscross pattern to 68 N•m (50 lbf•ft).
14. After the last hex nut is tightened to 68 N•m (50 lbf•ft), all of the hex nuts should be tightened again to 68 N•m (50 lbf•ft) in a circular pattern around the bolt circle.

15. Once completed, no more tightening is recommended.
16. For actuators with a top-mounted handwheel (see figure 9), mount the gear case assembly (key 41) on the actuator using the cap screws (key 16). Install the hex nuts (key 47) and travel stop cap screw (if used) on the actuator stem extension (key 36). Install the gear case cover (key 53) with the cap screws (key 54).
17. Mount the actuator on the valve, and secure with the actuator-to-bonnet bolting. Refer to the Installation section to connect the actuator stem to the valve plug stem.

For Actuators With the Top-Loaded Option

Disassembly

For key number locations refer to figure 7, and refer to the Top-Loaded Actuator Detail shown in figure 7. Also, refer to figure 5 for diaphragm construction details.

1. Remove the 40 cap screws (key 13) from the upper diaphragm casing (key 1) and remove the casing.
2. Remove the travel stop cap screw (key 12), hex nuts (key 24 and 241), washer (key 37), backup plate (key 6), diaphragm retainer (key 5), diaphragm (key 3), and diaphragm backup plate (key 246) with O-ring (key 240).
3. Remove the 40 cap screws (key 13) from the lower side of the casing adaptor (key 245) and remove the adapter.
4. Remove the diaphragm plate (key 4) with O-ring (key 240), diaphragm (key 3), diaphragm retainer (key 5), and backup plate (key 6).
5. Unscrew the six cap screws (key 11) and remove the seal bushing retainer (key 10). Remove the seal bushing (key 7). Remove and replace the seal bushing O-rings (keys 8 and 9) as necessary.

⚠ WARNING

To avoid personal injury due to the sudden, uncontrolled movement of parts, do not loosen the four hex nuts on the lower diaphragm casing when spring pressure is applied. Ensure that all spring precompression has been released.

6. Unscrew the four hex nuts that secure the lower diaphragm casing to the yoke assembly (key 67) and remove the lower diaphragm casing. Replace the yoke assembly O-rings (key 70) as necessary.
7. The actuator spring (key 18) and stem (key 144) can now be removed if necessary. Be sure to disconnect the stem connector (key 31) before removing the stem.
8. Unscrew the six cap screws (key 11) and remove the seal bushing retainer (key 10). Remove the seal bushing (key 7). Remove and replace the seal bushing O-rings (keys 8 and 9) as necessary.
9. Unscrew the four hex nuts that secure the lower diaphragm casing to the yoke assembly (key 67) and remove the lower diaphragm casing. Replace the yoke assembly O-rings (key 70) as necessary.
10. The actuator spring (key 18) and stem (key 144) can now be removed if necessary. Be sure to disconnect the stem connector (key 31) before removing the stem.
11. Refer to the size 100 actuator assembly procedures. Carefully clean and inspect all parts, and obtain any replacement parts required for reassembly.

Assembly

1. If the actuator stem (key 144) was removed, lubricate the threads on the stem with lithium grease lubricant (key 237).
2. Assemble the hex nuts, thrust bearing, and spring seat (keys 26, 25, 86, and 19) to the stem. Be certain that the thrust bearing race with the larger inside diameter faces the spring seat. Rotate the adjusting nut (key 25) to position the spring seat 305 mm (12 inches) from the end of the stem.

3. Install the actuator stem assembly into the yoke assembly (key 67). Place a support under the stem to position the lower end of the stem 254 mm (10 inches) above the bottom surface of the actuator (actuator-to-bonnet joint).

Note

When installing the lower diaphragm casing, install O-rings (key 70) into grooves found in the lower diaphragm casing before placing the casing on the yoke assembly. If the spring interferes with installation of the lower diaphragm casing, reposition the spring by rotating the adjusting nut.

4. Install the lower diaphragm casing (key 67), and secure it by tightening the four hex nuts.
5. Lubricate the seal bushing O-rings (keys 8 and 9) and the seal bushing (key 7) with lithium grease lubricant. Install the seal bushing O-rings, seal bushing (keys 8 and 9), and seal bushing retainer (key 7) and secure with four hex nuts.

CAUTION

Install the diaphragm with the fabric side facing away from the spring. Smooth the edge of the diaphragm to avoid wrinkling and be careful that the diaphragm fold does not get pinched when the diaphragm adaptor (key 245, figure 5) is installed.

CAUTION

If the diaphragm (key 3) is installed so air pressure is applied to the fabric side, it will immediately delaminate the sealing surface (smooth surface) from the fabric. The delamination can cause immediate failure of the diaphragm's ability to retain pressure.

6. Install the diaphragm backup plate, diaphragm retainer, diaphragm, O-ring, and diaphragm plate (keys 6, 5, 3, 240, and 4) on the actuator stem (key 144).
7. Carefully fold the diaphragm between the diaphragm backup plate (key 246) and the case adapter (key 245) while lowering the adapter onto the lower diaphragm casing assembly (key 67). Install all 40 cap screws (key 13) and finger tighten.

Note

When you replace actuator diaphragms in the field, take care to ensure the diaphragm casing cap screws are tightened to the proper load to prevent leakage, but not crush the material. Perform the following tightening sequence with a manual torque wrench for size 80 and 100 actuators.

CAUTION

Do not use lubricant on these cap screws and nuts. Fasteners must be clean and dry.
Overtightening the cap screws (key 13) can damage the diaphragm. Do not exceed 68 N•m (50 lbf•ft) torque.

8. Tighten the cap screws (key 13) in the following manner. The first four cap screws tightened should be diametrically opposed and 90 degrees apart. Tighten these four cap screws to 34 N•m (25 lbf•ft).
9. Tighten the remaining cap screws in a clockwise, crisscross pattern to 34 N•m (25 lbf•ft).
10. Repeat this procedure by tightening the four cap screws, diametrically opposed and 90 degrees apart, to a torque of 68 N•m (50 lbf•ft).
11. Tighten the remaining cap screws in a clockwise, crisscross pattern to 68 N•m (50 lbf•ft).
12. After the last cap screw is tightened to 68 N•m (50 lbf•ft), all of the cap screws should be tightened again to 68 N•m (50 lbf•ft) in a circular pattern around the bolt circle.
13. Once completed, no more tightening is recommended.

CAUTION

Install the diaphragm with the fabric side facing toward the spring. Smooth the edge of the diaphragm to avoid wrinkling and be careful that the diaphragm fold does not get pinched when the upper diaphragm casing (key 1) is installed.

14. Install the diaphragm backup plate, diaphragm, diaphragm retainer, backup plate, washer (keys 246, 3, 5, 6, 37, 241 and 24), hex nut (key 241), and hex nut (key 24).
15. For actuators with a top-mounted handwheel (see figure 9), screw the actuator stem extension (key 36) as far as it will go into the actuator stem connector (key 42) before tightening the hex nut (key 28).
16. For actuators without the handwheel, install the travel stop cap screw (key 12), and tighten the screw.
17. Position the upper diaphragm casing (key 1) on the diaphragm (key 3) and align the holes.

Note

When you replace actuator diaphragms in the field, take care to ensure the diaphragm casing cap screws are tightened to the proper load to prevent leakage, but not crush the material. Perform the following tightening sequence with a manual torque wrench for size 80 and 100 actuators.

CAUTION

Do not use lubricant on these cap screws and nuts. Fasteners must be clean and dry.

Overtightening the cap screws (key 13) can damage the diaphragm. Do not exceed 68 N•m (50 lbf•ft) torque.

18. Insert the cap screws (key 13) into the upper diaphragm casing (key 1), and finger tighten the screws.
19. Tighten the cap screws (key 13) in the following manner. The first four cap screws tightened should be diametrically opposed and 90 degrees apart. Tighten these four cap screws to 34 N•m (25 lbf•ft).
20. Tighten the remaining cap screws in a clockwise, crisscross pattern to 34 N•m (25 lbf•ft).
21. Repeat this procedure by tightening the four cap screws, diametrically opposed and 90 degrees apart, to a torque of 68 N•m (50 lbf•ft).
22. Tighten the remaining cap screws in a clockwise, crisscross pattern to 68 N•m (50 lbf•ft).
23. After the last cap screw is tightened to 68 N•m (50 lbf•ft), all of the cap screws should be tightened again to 68 N•m (50 lbf•ft) in a circular pattern around the bolt circle.

24. Once completed, no more tightening is recommended.
25. For actuators with a top-mounted handwheel (see figure 9), mount the gear case assembly (key 41) on the actuator using cap screws (key 16). Install the hex nuts (key 47) and travel stop cap screw (if used) on the actuator stem extension (key 36). Install the gear case cover (key 53) with cap screws (key 54).
26. Mount the actuator on the valve, and secure with the actuator-to-bonnet bolting. Refer to the Installation section to connect the actuator stem to the valve plug stem.

Size 80 Side-Mounted Handwheel

The side-mounted handwheel assembly (figure 8) is normally used as a manual operator. The handwheel can be mounted in either of two position orientations so that, regardless of valve plug action, counterclockwise rotation always opens the valve. The assembly is a continuously connected type with an indicator to show neutral position. By rotating the handwheel away from neutral, the handwheel can be used to limit travel in either direction, but not both directions at the same time.

A grease fitting is provided on the gear box for periodic gear lubrication with a general purpose grease.

Instructions are given below for complete disassembly and assembly. Perform the disassembly only as far as necessary to accomplish the required maintenance; then, begin the assembly at the appropriate step.

Key number location are shown in figure 8.

Disassembly

1. Complete steps 1 through 16 of the Disassembly portion of the Size 80 Actuator Maintenance section.
2. Unscrew the cap screws (key 88), and remove the spring case (key 85). Unscrew the cap screws (key 136), and remove the retaining flange (key 134). Do not lose the key (key 122).
3. Unscrew two screws (key 79), and remove the travel stop indicator (key 126).
4. Turn the handwheel (key 58) to raise the lower sleeve. Continue turning the handwheel until the lower sleeve is free of the worm gear (key 44). Lift out the lower sleeve, bearing and gear retainer, thrust bearing, and worm gear (keys 123, 45, 43, and 44).
5. The worm shaft (key 51) and associated parts can be removed in order to replace or lubricate them. First, remove the handwheel cap (key 127) and the handwheel (key 58). Do not lose the small ball or spring (keys 141 and 142).
6. Loosen the two set screws and unscrew the two worm retainers (keys 48 and 49). The ball bearings (key 50) will come out with the retainers. Remove the worm shaft (key 51).

Assembly

1. Pack the ball bearings (key 50) with lithium grease lubricant (key 237), and insert one ball bearing in the back worm retainer (key 48).
2. Thread the back worm retainer and ball bearing (keys 48 and 50) into the gear case. Align the set screw slot in the worm retainer with the set screw hole in the gear case, insert the set screw, and tighten.
3. Coat the worm shaft (key 51) threads with lithium grease lubricant, and slide the shaft into the gear case (key 41) so that the end of the shaft fits snugly in the back worm retainer.
4. Insert the bearing in the front worm retainer (key 49), and thread the retainer and ball bearing into the gear case. Align the set screw slot in the retainer with the set screw hole in the gear case, insert the set screw, and tighten.
5. Put the spring and ball (keys 142 and 141) in the handwheel (key 58). Slide the handwheel onto the worm shaft (key 51). Thread the handwheel cap (key 127) onto the worm shaft.
6. Pack the two thrust bearings (key 43) with lithium grease lubricant. Install one thrust bearing; then install the worm gear (key 44), followed by the second thrust bearing and the bearing and gear retainer (key 45).

7. The lower sleeve (key 123) has two screw holes in one end. Coat the sleeve threads with lithium grease lubricant, slide the end of the lower sleeve with the holes into the thrust bearing (key 43), turn the handwheel, and feed the sleeve through the worm gear. Continue turning the handwheel until the lower sleeve protrudes from the gear case. Fasten the travel stop indicator (key 126) to the sleeve with two machine screws (key 79).
8. Install the key (key 122) on the retaining flange (key 134).
9. Install the retaining flange (key 134) so that the key engages the slot in the lower sleeve. Secure the retaining flange with the cap screws (key 136).
10. Adjust the set screws (key 121) to eliminate free play in the bearings.

Note

Overtightening the set screws will make handwheel operation difficult.

11. Coat the spring adjustor (key 74) threads with lithium grease lubricant and install it over the lower sleeve.
12. Pack the thrust bearing (key 86) with lithium grease lubricant, and install it on the spring adjustor (key 74) as shown in figure 8.
13. Slide the spring case (key 85) into position, and secure with cap screws (key 88).
14. Complete steps 3 through 16 of the Assembly procedure in the Size 80 Actuator Maintenance section.

Size 80 Hydraulic Snubber

The size 80 667 actuator is available with a hydraulic snubber, as shown in figure 8, to aid vertical stability of the actuator stem movement. The snubber is adjusted by rotating the adjusting screws (key 104, figure 8) counterclockwise out of the reservoir (key 99, figure 8) to increase damping action and clockwise to decrease damping action. The adjusting screw on the right (the top one of the two adjusting screws in section B-B of figure 8) regulates downward damping action, and the screw on the left regulates upward damping action.

Size 100 Top-Mounted Handwheel (Adjustable Down Travel Stop)

Key numbers are shown in figure 9.

A top-mounted handwheel assembly is normally used as an adjustable-down travel stop to limit full extension of the actuator stem. Counterclockwise rotation will compress the spring and move the actuator stem upward. Clockwise rotation of the handwheel (key 58) allows spring action to return the actuator stem (key 144) downward.

Instructions are given below for complete disassembly and assembly. Disassemble only as far as necessary to accomplish the required maintenance; then, begin the assembly at the appropriate step.

Disassembly

1. Isolate the control valve from the line pressure, release pressure from both sides of the valve, and drain the process media from both sides of the valve. If using a power actuator, also shut off all pressure lines to the power actuator, release all pressure from the actuator. Use lock-out procedures to be sure that the above measures stay in effect while you work on the equipment.
2. Bypass the control valve. Reduce the loading pressure to atmospheric (refer to the Maintenance section), and remove the tubing or piping from the diaphragm casing.
3. Unscrew the cap screws (key 54), and remove the gear case cover (key 53).
4. Loosen the set screws (key 52) in the front and back worm retainers (keys 48 and 49) and the handwheel (key 58).

5. Remove the retaining ring (key 60), and remove the handwheel.
6. Remove front and back worm retainers (keys 48 and 49) and the bearings (key 50).
7. Remove the worm shaft (key 51).
8. Remove the power screw assembly (key 46) by placing a wrench on the double hex nuts (key 47) and unscrew the assembly from the actuator stem extension (key 36). The bearing and gear retainer, thrust bearing, and worm gear (keys 45, 43, and 44) will come out with the power screw.

Assembly

1. The front and back worm retainers (keys 48 and 49) each have a slot in their threads for a set screw (key 52). Pack the ball bearings (key 50) with lithium grease, and insert one ball bearing into the back worm retainer (key 48).
2. Thread the back worm retainer and ball bearing into the gear case. Align the slot in the worm retainer with the set screw hole in the gear case, insert the set screw (key 52), and tighten.
3. Coat the worm shaft (key 51) threads with lithium grease lubricant, and slide the shaft into the gear case so that the end of the shaft fits snugly in the back worm retainer.
4. Insert the bearing into the front worm retainer (key 49), and thread the retainer and ball bearing into the gear case. Align the slot in the retainer with the hole in the gear case, insert the set screw (key 52), and tighten.
5. Slide the handwheel onto the worm shaft (key 51), and install the retaining ring (key 60).
6. Pack the two thrust bearings (key 43) with lithium grease lubricant. Install one thrust bearing, then the worm gear (key 44), followed by the second thrust bearing and the bearing and gear retainer (key 45).
7. Coat the power screw threads (key 46) with lithium grease lubricant. Slide the power screw into the thrust bearing (key 43), turn the handwheel, and feed the sleeve through the worm gear.
8. Install the gear case cover (key 53), and tighten the cap screws (key 54).
9. Adjust the set screws (key 55) to eliminate free play in the bearings.

Note

Overtightening the set screws (key 55) will make handwheel operation difficult.

Parts Ordering

Each actuator has a serial number stamped on the nameplate. Always refer to this number when corresponding with your Emerson Process Management sales office regarding replacement parts or technical information. Also, always refer to the 11-character part number of each recommended spare part, as found in the following parts list.

WARNING

Use only genuine Fisher replacement parts. Components that are not supplied by Emerson Process Management should not, under any circumstances, be used in any Fisher valve, because they may void your warranty, might adversely affect the performance of the valve, and could cause personal injury and property damage.

Note

Neither Emerson, Emerson Process Management, nor any of their affiliated entities assumes responsibility for the selection, use, or maintenance of any product. Responsibility for the selection, use, and maintenance of any product remains with the purchaser and end user.

Parts Kits

Actuator Repair Kit

Parts kit includes keys 8, 9, and 70.

Key	Description	Part Number
	Size 80 R667X000802	

Parts List

Note

Part numbers are shown for recommended spares only. For part numbers not shown, contact your Emerson Process Management sales office.

Actuator

Key	Description	Part Number
1	Upper Diaphragm Casing	
2	Spacer	
3*	Diaphragm	
	Size 80	
	Nitrile	2R6376X0082
	Silicone	18B2713X062
	Size 100 std	
	Nitrile	20A2551X012
	Size 100 top loaded	
	Nitrile (2 required)	20A2551X012
4	Diaphragm Plate, upper	
5	Diaphragm Retainer	
6	Backup Plate	
7*	Seal Bushing	
	Size 80, glass-filled PTFE	1H7441X0022
	Size 100, Brass	20A2582X012
8*	O-Ring, nitrile (2 required)	
	Size 80	1D542906992
	Size 100	1H8627X0042
9*	O-Ring, nitrile	
	Size 80	1D439206992
	Size 100	1R834206992
10	Seal Bushing Retainer	
11	Cap Screw	
12	Cap Screw	
13	Cap Screw	
14	Hex Nut	
15	Diaphragm casing Cover	
16	Cap Screw	
17	Y602 Vent Assembly	
18	Spring, steel	See following table

Key	Description	Part Number
19	Spring Seat	
19	Spring Plate	
20	Spring Guide	
21	Cap Screw	
22	Washer	
24	Hex Nut	
25	Hex Nut	
26	Hex Nut	
30	Cap Screw	
31	Stem Connector Assembly	
32	Travel Scale	
33	Machine Screw	
34	Travel Indicator	
35	Cap Screw	
37	Washer	
39	Nameplate	
40	Drive Screw	
60	Retaining Ring	
62	Hex Bushing	
63	Lifting Pin	
64	Lower Diaphragm Casing	
65	Shroud Plate	
66	Cap Screw	
67	Lower Diaphragm Casing, yoke & tie rod assembly	
69	Hex Jam Nut	
70*	Gasket, composition	
	Size 80 only	1H7369X0012
70*	O-Ring, nitrile (4 required)	
	Size 100 only	1C415706992
71	Diaphragm Plate, lower	
72	Snap Ring	
73	Yoke	
74	Spring Adjustment screw	
78	Pipe Bushing	
79	Machine Screw	
84	Travel Stop	
85	Spring Case	
86	Thrust Bearing	
87	Cover Band Assembly	
88	Cap Screw	
89	Spring Case Adaptor	
90	Cap Screw	
91	Hex Nut	
92	Pipe Bushing	
144	Actuator Stem	
235	Bushing	
236	Tag/Wire Assembly	
237	Lithium Grease, 14 oz. (0.396 kg) can	
238	Gasket Sealant (hard set), 11 oz. (0.311 kg) tube	
240*	O-Ring, nitrile	
	Size 100 only	
	Std (1 required) and w/top loaded (2 required)	1C339006992
241	Hex Nut	
242	Y602-12 Vent Assembly	
243	Warning Plate	
244*	Gasket, composition	
	Size 100	
	Top Loaded only (part not shown)	11A3391X012
245	Case Adaptor	
246	Backup Plate	
249	Bushing, split yoke	
250	Yoke Bushing Holder	
251	Yoke Bushing Retainer	
252	Cap Screw	

*Recommended spare parts

Key 18 Spring, steel

ACTUATOR SIZE	RANGE		TRAVEL		COMPRESSION RATE		MAXIMUM LOAD		PART NUMBER	COLOR CODE
	bar	psi	mm	Inches	N/mm	Lb/in	N	Lb		
80	0.2-1	3-15	76	3	175.1	1000	25,042	5630	1H747727082	Red
	0.2-1	3-15	51	2	288.9	1650	35,139	7900	1H747527082	Lt. Blue
	0.3-1.7	5-25	76	3						
	0.4-2	6-30	38	1.5	367.7	2100	47,148	10,600	1H747327082	Yellow
	0.4-2	6-30	76	3						
	0.3-1.7	5-25	51	2	455.3	2600	47,148	10,600	1H747627082	Lt. Green
	0.2-1	3-15	29	1.125	542.58	3100	61,382	13,800	1H747027082	White
0.4-2	6-30	51	2							

Key 18 Spring, steel

ACTUATOR SIZE	COMPRESSION RATE		MAXIMUM LOAD		PART NUMBER
	N/mm	Lb/in	N	Lb	
100	310.8	1775	77,840	17,500	10A2561X012
	516.5	2950	111,200	25,000	10A2562X012
	787.9	4500	160,128	36,000	10A2563X012
	1050.6	6000	200,160	45,000	10A2564X012

Side-Mounted Handwheel Size 80

Key	Description	Part Number
29	Hand Grip	
38	Hand Grip Bolt	
41	Gear Case	
43	Thrust Bearing	
44	Worm Gear	
45	Bearing & Gear Retainer	
48	Back Worm Retainer	
49	Front Worm Retainer	
50	Ball Bearing	
51	Worm Shaft	
57	Grease Fitting	
58	Handwheel	
121	Set Screw	
122	Key	
123	Lower Sleeve	
124	Machine Screw	
126	Travel Stop Indicator	
127	Handwheel Cap	
134	Retaining Flange	
135	Travel Stop Nut	
136	Cap Screw	
137	Set Screw	
138	Cap Screw	
139	Travel Stop Scale	
140	Travel Stop Indicator Bracket	
141	Ball	
142	Spring	
143	Machine Screw	
237	Lithium Grease, 14 oz. (0.396 kg) can	
238	Gasket Sealant (pliable film), 11 oz. (0.311 kg) tube	

Top-Mounted Handwheel Size 100

Key	Description	Part Number
28	Hex Nut	
36	Actuator Stem Extension	
41	Gear Case	
42	Actuator Stem Connector	
43	Thrust Bearing	
44	Worm Gear	
45	Bearing & Gear Retainer	
46	Power Screw Assembly	
47	Hex Nut	
48	Back Worm Retainer	
49	Front Worm Retainer	
50	Ball Bearing	
51	Worm Shaft	
52	Set Screw	
53	Gear Case Cover	
54	Cap Screw	
55	Set Screw	
56	Hex Nut	
57	Grease Fitting	
58	Handwheel	
59	Woodruff Key	
61	Slot Cover	

Figure 6. Size 80 Fisher 667 Actuator

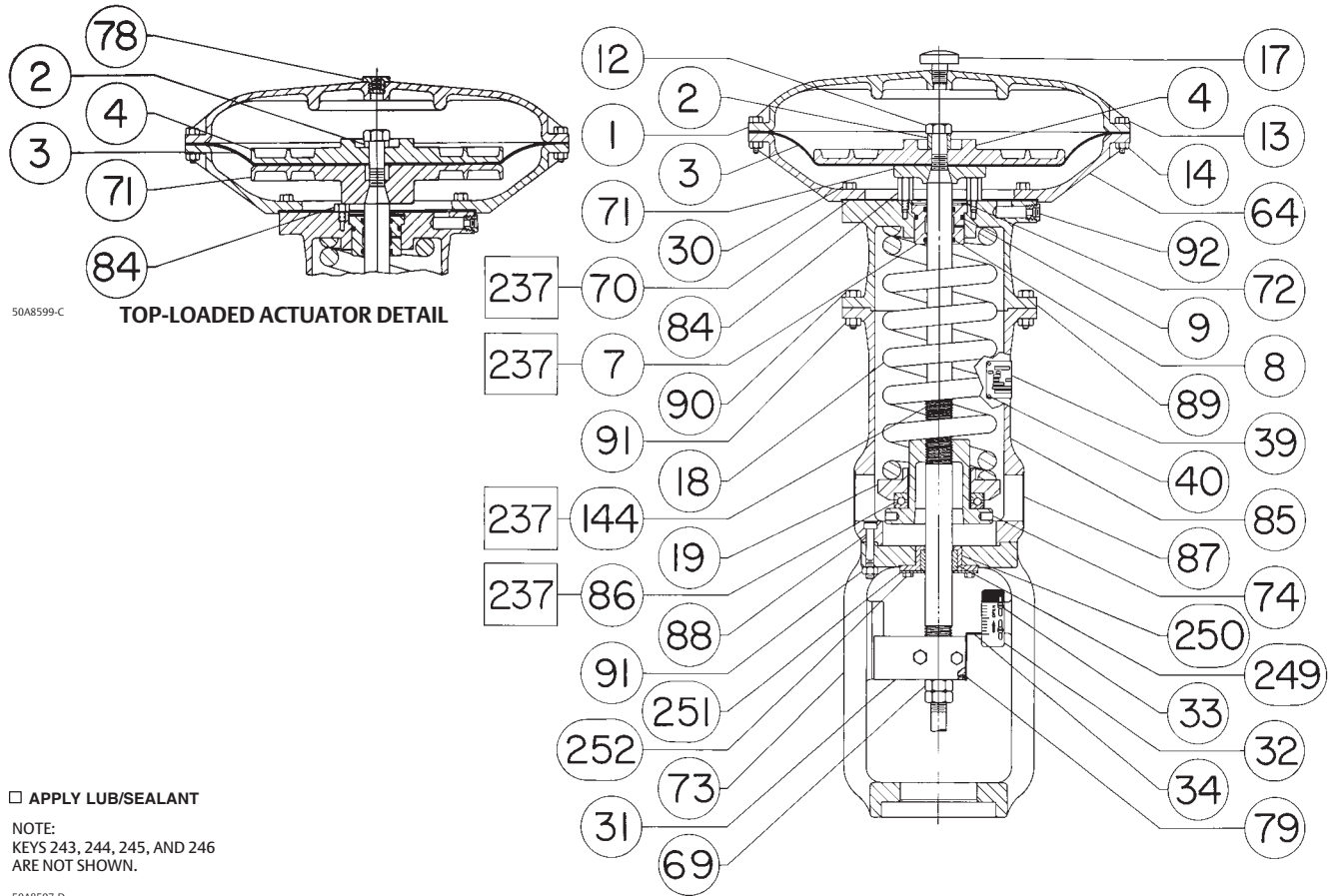

□ APPLY LUB/SEALANT
 NOTE:
 KEYS 243, 244, 245, AND 246
 ARE NOT SHOWN.

Hydraulic Snubber Size 80

Key	Description	Part Number	Key	Description	Part Number
			104	Adjusting Screw	
			105	Hex Nut	
			106	Cap Screw	
			107*	O-Ring, nitrile	1H972406992
			108	Hydraulic fluid, 2 gal (7.6L)	
			109*	O-Ring, nitrile (2 required)	1E591406992
			110	Orifice	
			111	Bypass & Check Valve Plug	
			112	Spring	
			113	E-Ring	
			114	Bushing	
			115	Flange	
			116	Packing Sleeve	
			117	Machine Screw	
			118*	Packing, nitrile (8 required)	1P540806992
			119*	Packing, chloroprene & cotton (4 required)	1P540906992
			120*	O-Ring, nitrile (2 required)	1P541206992
23	Stem & Piston Assembly				
93	Cylinder				
94	Cylinder Head				
95	Retaining Ring				
96*	O-Ring, nitrile (2 required)	1F449206992			
97*	Piston Ring, iron (2 required)	1C710321992			
98	Pipe Plug				
99	Reservoir				
100*	O-Ring, nitrile	1H624706992			
101	Cap Screw				
102	Pipe Plug				
103*	O-Ring, nitrile (2 required)	1D687506992			

*Recommended spare parts

Figure 7. Size 100 Fisher 667 Actuator

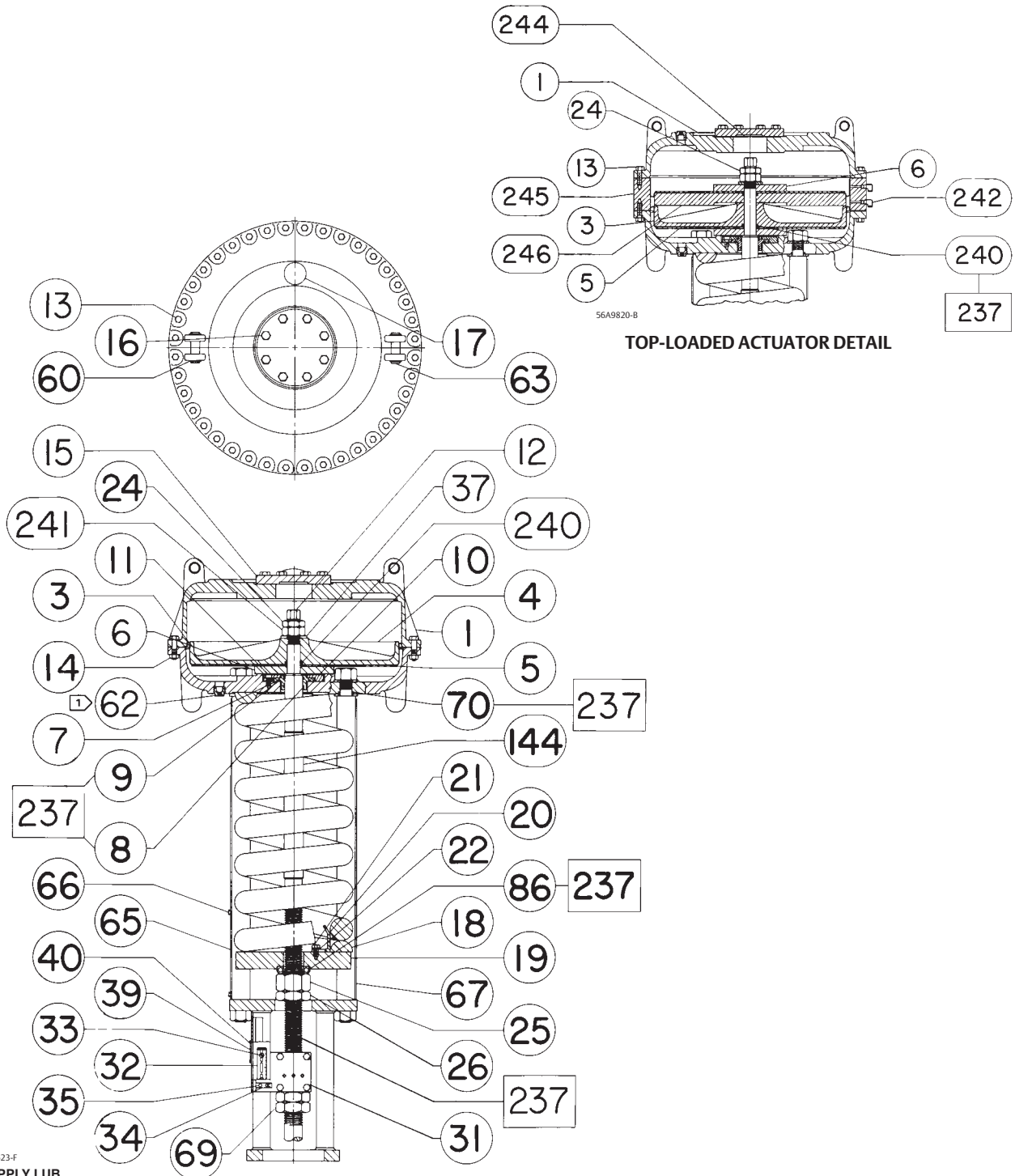

56A9820-B

TOP-LOADED ACTUATOR DETAIL

50A2623-F

□ APPLY LUB

NOTES:

THIS PART IS LOCATED 90° TO FRONT OF POSITION SHOWN
 2. KEYS 243 AND 244 ARE NOT SHOWN

Figure 8. Size 80 Fisher 667 Actuator with Side-Mounted Handwheel and Hydraulic Snubber

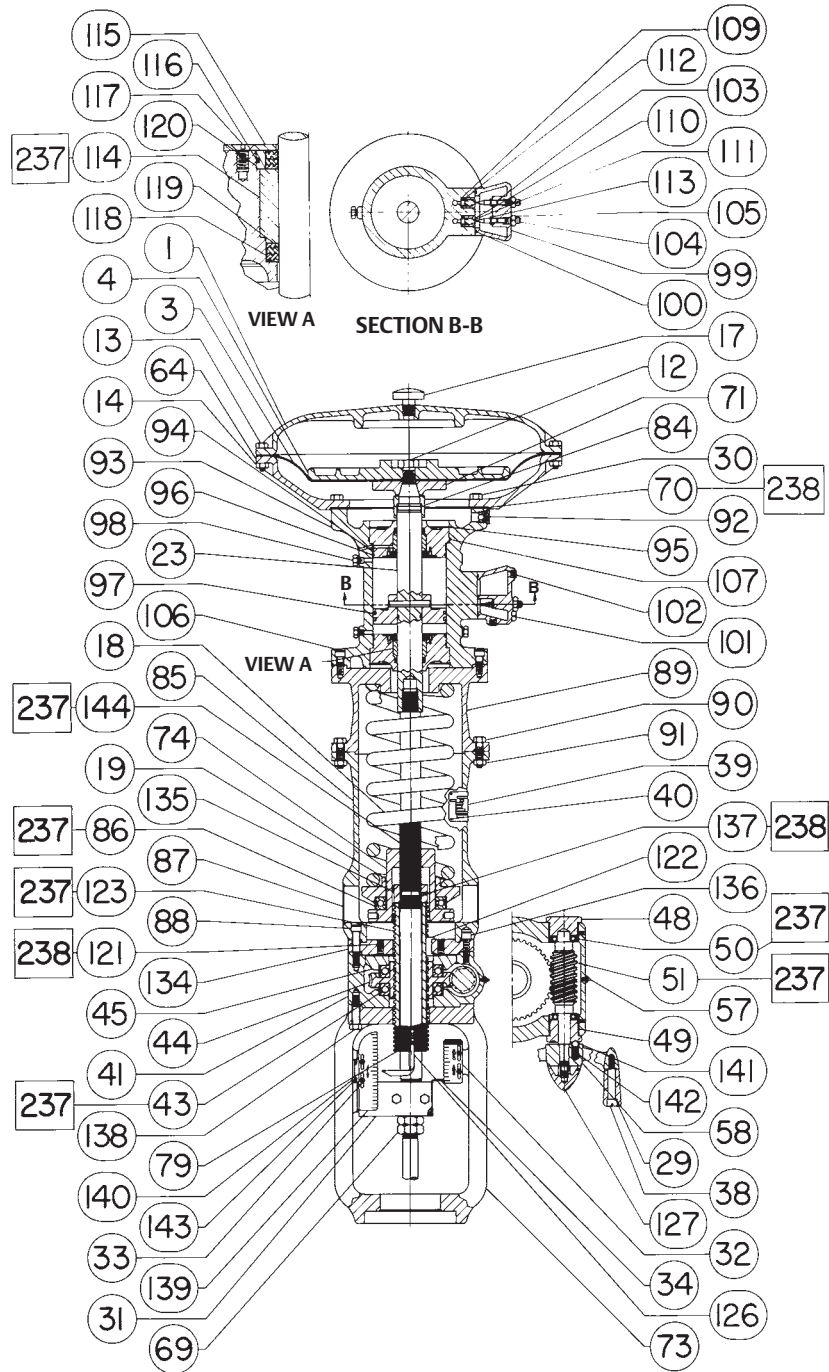

50A8759-C

□ APPLY LUB/SEALANT

Figure 9. Size 100 Top-Mounted Handwheel

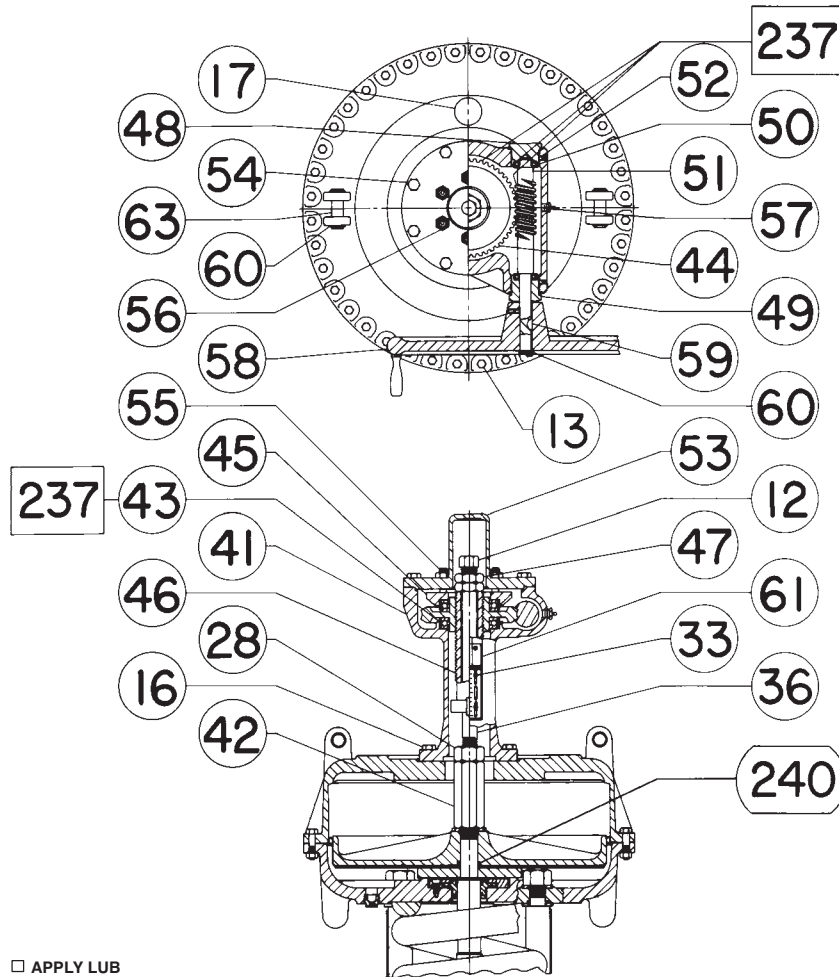

Fisher is a mark owned by one of the companies in the Emerson Process Management business division of Emerson Electric Co. Emerson Process Management, Emerson, and the Emerson logo are trademarks and service marks of Emerson Electric Co. All other marks are the property of their respective owners.

The contents of this publication are presented for informational purposes only, and while every effort has been made to ensure their accuracy, they are not to be construed as warranties or guarantees, express or implied, regarding the products or services described herein or their use or applicability. All sales are governed by our terms and conditions, which are available upon request. We reserve the right to modify or improve the designs or specifications of such products at any time without notice. Neither Emerson, Emerson Process Management, nor any of their affiliated entities assumes responsibility for the selection, use or maintenance of any product. Responsibility for proper selection, use, and maintenance of any product remains solely with the purchaser and end user.

Emerson Process Management
 Marshalltown, Iowa 50158 USA
 Sorocaba, 18087 Brazil
 Chatham, Kent ME4 4QZ UK
 Dubai, United Arab Emirates
 Singapore 128461 Singapore

www.Fisher.com