

BO638.5SS / P650.5SS
60 cm Multifunction
self-cleaning pyrolytic
built-in oven

INSTRUCTION MANUAL

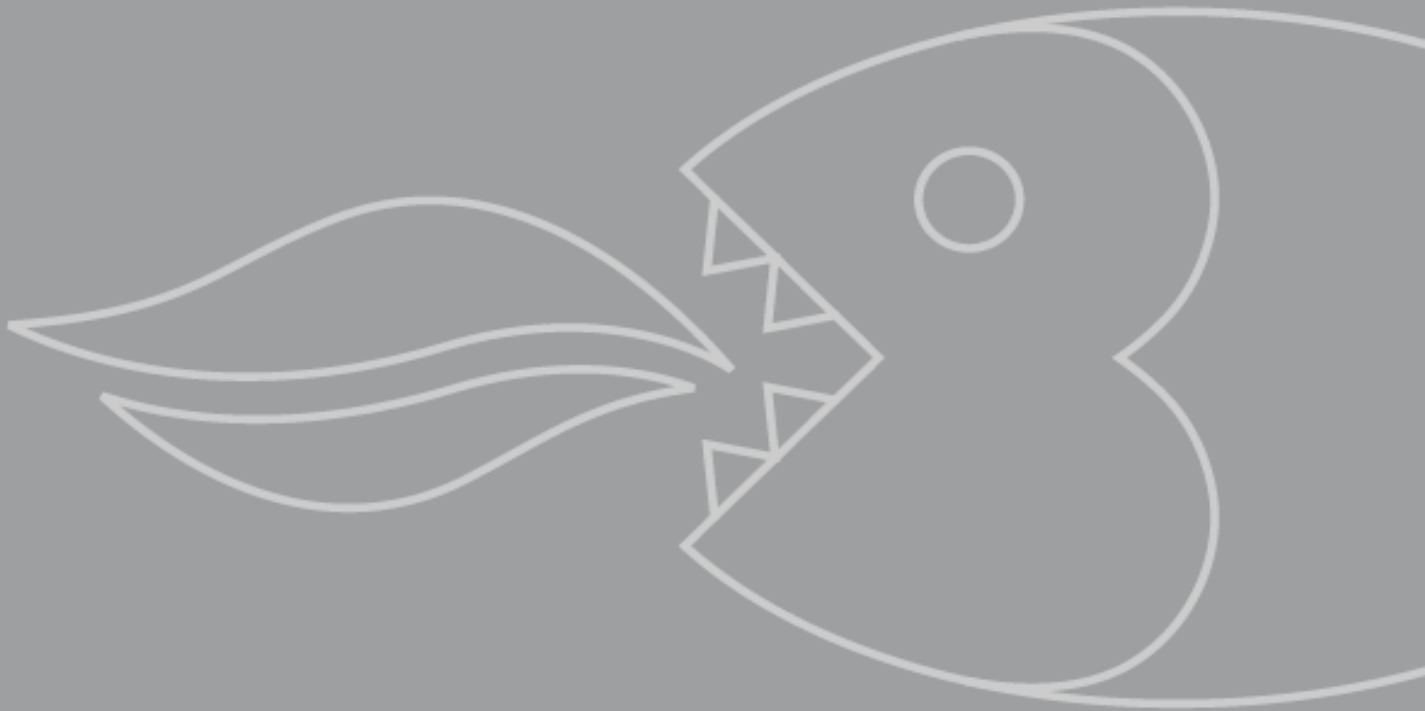

User Manual for your Baumatic

BO638.5SS / P650.5SS

**Multifunction self-cleaning
pyrolytic built-in oven.**

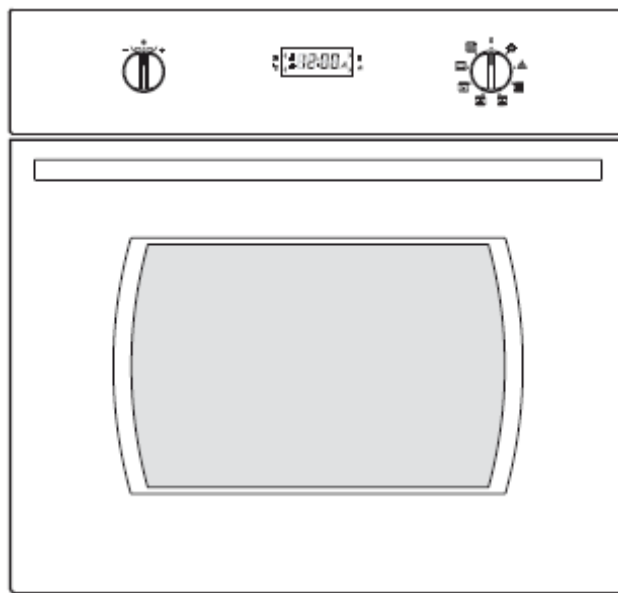

NOTE: This User Instruction Manual contains important information, including safety & installation points, which will enable you to get the most out of your appliance. Please keep it in a safe place so that it is easily available for future reference; for you or any person not familiar with the operation of the appliance.

Contents

Environmental note	4
Important safety information	5 – 7
Specifications	8 - 10
Product and aperture dimensions	8
Product specifications	8
Standard accessories	8
Optional extra	8
Electrical details	9
Cooling fan	9
Control panel	10
Oven programmer/timer display	10
Setting and using the oven	11 - 18
Initial power-up	11
Setting the time of day	11
Before first use	12
The oven timer	12
Setting the minute minder function	13
Setting the duration function	14
Selecting the end cook function	15
Setting the start and end time function	16 – 17
Cancelling a timer function	17 - 18
Adjusting the audible signal	18
Locking the oven door	18
Selecting a cooking function and temperature	19 - 24
Selecting an oven function	19
Oven functions	19 - 20
Thermostat control knob	21
Cooking function default temperature table	22
Cooking guidelines	23
Warnings	23 - 24
Cleaning and maintenance	25 - 28
Pyrolytic cleaning	25 - 26
General cleaning instructions	26
Removing the oven door for cleaning	27 - 28
Replacing the oven bulb	29
Installation	29 – 32
Electrical connection	29 - 30
Installing the oven into the kitchen cabinet	31
Positioning the appliance	31
Ventilation requirements	32
My appliance isn't working correctly	33 – 35
Contact details	39

This appliance is marked according to the European directive 2002/96/EC on Waste electrical and Electronic Equipment (WEEE). By ensuring this product is disposed of correctly, you will help prevent potential negative consequences for the environment and human health, which could otherwise be caused by inappropriate waste handling of this product.

The symbol  on the product, or on the documents accompanying the product, indicates that this appliance may not be treated as household waste. Instead it shall be handed over to the applicable collection point for the recycling of electrical and electronic equipment.

Disposal must be carried out in accordance with local environmental regulations for waste disposal.

For more detailed information about treatment, recovery and recycling of this product, please contact your local city office, your household waste disposal service or the shop where you purchased the product.



- The packaging materials that Baumatic uses are environmentally friendly and can be recycled.
- Please discard all packaging material with due regard for the environment.

IMPORTANT SAFETY INFORMATION



Your safety is of the utmost importance to Baumatic. Please make sure that you read this instruction booklet **before** attempting to install or use the appliance. If you are unsure of any of the information contained in this booklet, please contact the Baumatic Advice Line.

General Information

- This appliance is designed for domestic household use and can be built into a standard kitchen cabinet or housing unit.
- **IMPORTANT:** *The adjacent furniture or housing and all materials used in the installation **must** be able to withstand a minimum temperature of 85°C above the ambient temperature of the room it is located in, whilst in use.*
- Certain types of vinyl or laminate kitchen furniture are particularly prone to heat damage or discolouration at temperatures below the guidelines given above.
- Any damage caused by the appliance being installed in contravention of this temperature limit, or by placing adjacent cabinet materials closer than 4mm to the appliance, **will be the liability of the owner.**
- For use in **leisure accommodation vehicles**, please refer to the appropriate information given in the installation instructions for this appliance.
- The use of this appliance for any other purpose or in any other environment without the express agreement of Baumatic Ltd. will invalidate any warranty or liability claim.
- Your new appliance is guaranteed against electrical or mechanical defects, subject to certain exclusions that are noted in Baumatic's Conditions Of Guarantee. The foregoing does not affect your statutory rights.
- **Repairs may only be carried out by Baumatic service engineers or their authorised service agents.**

Warning and safety instructions

- This appliance complies with all current European safety legislation. Baumatic do wish to emphasise that this compliance does not remove the fact that the appliance surfaces ***will become hot during use and retain heat after operation.***

Child Safety

- Baumatic strongly recommend that babies and young children are prevented from being near to the appliance and not allowed to touch the appliance ***at any time.***
- If it is necessary for younger family members to be in the kitchen, please ensure that they are kept under close supervision at all times.

General Safety

- ***Do not*** place heavy objects on the oven door or lean on the oven door when it is open, as this can cause damage to the oven door hinges.
- ***Do not*** leave heated oil or fat unattended, as this is a fire risk.
- ***Do not*** place pans or baking trays directly on the base of the oven cavity, or line it with aluminium foil.
- ***Do not*** allow electrical fittings or cables to come into contact with areas on the appliance that get hot.
- ***Do not*** use the appliance to heat the room it is located in or to dry clothing.
- ***Do not*** install the appliance next to curtains or soft furnishings.
- ***Do not*** attempt to lift or move cooking appliances by using the oven door or handle, as this may cause damage to the appliance or result in injury to the person lifting the appliance.

Cleaning

- Cleaning of the oven should be carried out on a regular basis.
- Great care should be taken whilst using this appliance and when following the cleaning procedure.
- **IMPORTANT:** *The appliance must be disconnected from the mains before following the cleaning procedure (except for the Pyrolytic cleaning function).*

Installation



This appliance must be correctly installed by a suitably qualified person, strictly in accordance with the manufacturer's instructions.

- ***Baumatic Ltd. declines any responsibility for injury or damage, to person or property, as a result of improper use or installation of this appliance.***
- Heat, steam and moisture will be created during use of the appliance, take care to avoid injury and ensure that the room is adequately ventilated. If the appliance is going to be used for prolonged periods of time, then additional ventilation may be required.
- Please consult with your qualified installer if you are in any doubt about the amount of ventilation that you will require.

Declaration of conformity

- This appliance complies with the following European Directives:
 - 2006/95/EC regarding "low voltage"
 - 2004/108/EC regarding "electromagnetic disturbances"
 - Regulation (EC) N° 1935/2004 regarding "materials in contact with food"
- The above directives comply with 93/68/EEC regarding CE marking.
- The manufacturer declares that the oven is built using certified materials and requires the appliance to be installed in accordance with the standards currently in force. This appliance must be used by a trained person for domestic purposes only.

Specifications

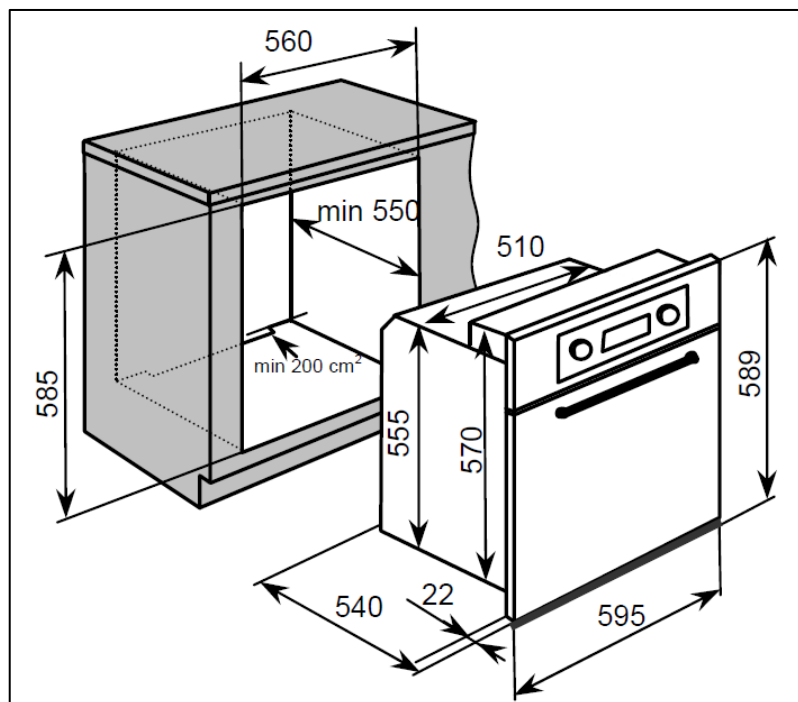

Product Dimensions

Height: 589 mm
Width: 595 mm
Depth: 540 mm

Aperture dimensions

Height: 585 mm
Width: 560 mm
Depth: 550 mm (min)

Product specifications

- 8 Functions (BO638.5SS)
- 10 Functions (P650.5SS)
- **Energy efficiency class: A**
- Gross oven capacity: 63 litres
- Net oven capacity: 54 litres
- LED full programmer
- Oven light
- Cooling fan
- Automatic safety door-lock (when in pyrolytic mode)
- Triple-glazed removable door
- Mark resistant coating

Standard accessories

- Enamelled baking tray
- Safety shelves (x2)

Optional extra

- BPS2 Pizza stone

Electrical details

Rated Voltage:	230 - 240 V. 50 - 60 Hz
Supply Connection:	13A (BO638.5SS) double pole switched fused outlet with 3mm contact gap.
Max Rated Inputs:	2.60 kW (BO638.5SS)
Supply Connection:	16A (P650.5SS) double pole switched fused outlet with 3mm contact gap.
Max Rated Inputs:	3.20 kW (P650.5SS)
Mains Supply Lead:	3 x 1.5 mm ²
Oven Light Bulb:	25 W/300°C screw type pygmy

Cooling fan

- A tangential cooling fan is fitted inside of this appliance, to make the internal temperature of the oven stable and the external surface temperature lower.
- After you have finished cooking and switched off the oven, the cooling fan will continue to run for a period of time afterwards. The length of time will depend on how long the oven has been switched on for and at how high a temperature.

For future reference please record the following information which can be found on the rating plate and the date of purchase which can be found on your sales invoice. The rating plate for your oven can be located by opening the oven door and looking on the right hand side of the oven chassis.

Model Number

Serial Number

Date of Purchase

Control Panel



Oven control knobs

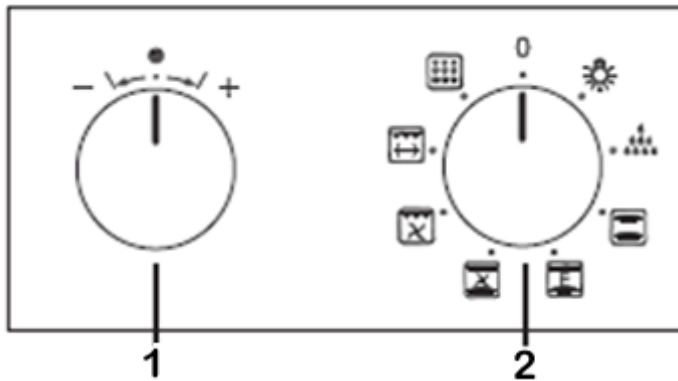

(For reference only, actual product may differ slightly)

- 1) Temperature and timer control knob
- 2) Oven function selector knob

Oven timer LED display



- 3) Clock/Timer symbol
- 4) Minute minder symbol
- 5) LED digit display
- 6) Lock symbol
- 7) Pre-heat / audible level symbol
- 8) Automatic cooking symbol
- 9) Oven in use symbol
- 10) Heating / hot symbol

Initial set-up of your oven

Power-up

When your oven is connected to the power supply for the first time (or after a power cut), the oven will perform a self-test to check that the latch mechanisms of the door lock are functioning properly. This safety feature of the Pyrolytic oven will last approximately 30 seconds. During this operation the door lock symbol **(6)** will flash. Do not try to open the oven door until the door lock symbol **(6)** has turned off.

Setting the time of day

After your appliance is connected to your mains supply for the first time, you must set the time of day before you can use the oven.

- When the oven is connected to your mains supply for the first time (or after a power cut), the digits on the LED display **(5)** will flash.

*NOTE: In order to set the time of day, the oven function selector knob **(2)** must be in the off ("0") position.*

- Whilst the digits are flashing, use the control knob **(1)** to adjust the time. Turn the control knob right (plus) to increase the time and left (minus) to decrease the time.
- When you start adjusting the time, the time of hour will flash and can be set first. You can then proceed to set the time of minute.
- Push the control knob to change between hours and minutes.
- When the correct time of day is shown on the LED display, release the control knob **(1)** and wait a few seconds. The whole time of day will flash in the LED display **(5)** for a few seconds, and then the time will stop flashing and the oven is ready to use.

IMPORTANT: Pushing the control knob (1) will toggle between the time of day and the minute minder. When the minute minder is selected, the minute minder symbol will be displayed (4).

NOTE: You can set the time of day at any time by following the steps outlined above. The selector knob must be in the off ("0") position and you change the time by using the control knob.

NOTE: You can adjust the unit value by turning the control knob once per unit. You can also scroll quickly through the units by holding the control knob to the left or right.

Before first use

- To remove any residue from the oven that may have been left from the manufacturing process, you should select the fan oven function and set the thermostat to its maximum temperature setting.
- It is perfectly normal for a smell to be produced during this process.
- You should make sure that any windows in the room are left open during this process.
- It is advisable for you not to remain in the room whilst the burning off process is taking place.
- You should leave the oven on maximum setting for 30 – 40 minutes.
- After the oven cavity has cooled, it should then be cleaned with warm soapy water, using either a sponge or soft cloth. No abrasive cleaners should be used.
- Outer parts of the oven should be cleaned with warm soapy water, using either a sponge or soft cloth. No abrasive cleaners should be used.
- We would recommend that an appropriate stainless steel cleaner and polish is regularly used on the stainless steel surfaces of this appliance.

Timer functions

The minute minder function

The minute minder function is a countdown time that can be set on the oven. When the countdown time has finished, an audible signal will sound.

- Press the control knob **(1)** once or until the minute minder symbol **(4)** is displayed.
- Whilst the digits are flashing, use the control knob **(1)** to adjust the time. Turn the knob right (plus) to increase the time and left (minus) to decrease the time.
- The default time is 30 minutes. The minimum countdown time that can be set is 1 minute; the maximum countdown time is 240 minutes (4 hours).

- When you start adjusting the time, the hour of time will flash and can be set first. You can then proceed to set the time of minute.
- Push the control knob to change between hours and minutes.
- When the correct time is shown on the LED display, release the control knob **(1)** and wait a few seconds. The whole countdown time will flash in the LED display **(5)** for a few seconds, and then the time will stop flashing. The minute minder will be set and will begin its countdown immediately.

*NOTE: After a few seconds the LED display will return to showing the time of day, but the minute minder symbol **(4)** will still be activated and displayed in the LED screen **(5)**.*

- At the end of the countdown time, an audible signal will sound and the minute minder symbol will flash. The audible signal will sound for a few minutes before switching off, or you can silence it by pressing the control knob.

IMPORTANT: If the oven is in use whilst using the minute minder function, the oven WILL NOT switch off at the end of the countdown time. YOU MUST turn the oven function selector knob to the OFF position ("0").

IMPORTANT: Pushing the control knob (1) will toggle between the time of day and the minute minder. When the minute minder is selected, the minute minder symbol will be displayed (4).

The duration timer function (semi-automatic cooking)

This function will allow you to set a countdown time similar to the minute minder function, however the oven will switch off at the end of the cooking time (Duration timer).

- Place the food that you want to cook inside of the oven and close the door.
- Select an oven function and cooking temperature using the relevant control knobs.
- Press down the control knob **(1)** to toggle through the timer functions.
- When "dur" appears on the LED display you have selected the duration timer.

- Whilst "dur" is flashing, use the control knob **(1)** to adjust the time. Turn the knob right (plus) to increase the time and left (minus) to decrease the time.
- The default time is 30 minutes. The minimum countdown time that can be set is 1 minute; the maximum countdown time is 240 minutes (4 hours).
- When you start adjusting the time, the hour of time will flash and can be set first. You can then proceed to set the time of minute.
- Push the control knob to change between hours and minutes.
- When the correct time is shown on the LED display, release the control knob **(1)** and wait a few seconds. The whole countdown time will flash in the LED display **(5)** for a few seconds, and then the time will stop flashing. The duration timer will be set and will begin its countdown immediately.

*NOTE: After a few seconds the LED display will return to showing the time of day, but the timer symbol **(3)**, oven in use symbol **(9)**, and the automatic cooking symbol **(8)** will still be activated in the LED display **(5)**.*

- At the end of the countdown time the oven will stop heating, an audible signal will sound and the automatic cooking symbol **(8)** and the oven in use symbol **(9)** will flash. The audible signal will sound for a few minutes before switching off or you can silence it by pressing the control knob **(1)**.
- **IMPORTANT:** Remember to turn the oven function selector knob to the off position ("0") after each use.

The end of cooking function

This function is similar to the semi-automatic function, however instead of setting a countdown time, you select the time of day that you want the oven to switch off at (End timer).

- Place the food that you want to cook inside of the oven and close the door.
- Select an oven function and cooking temperature using the relevant control knobs.
- Press down the control knob **(1)** to toggle through the timer functions.
- When "end" appears on the LED display you have selected the end of cooking timer.
- Whilst "end" is flashing, use the control knob **(1)** to adjust the time. Turn the knob right (plus) to increase the time and left (minus) to decrease the time.
- The default time is the current time of day. The minimum countdown time that can be set is 1 minute; the maximum countdown time is up to 24 hours.
- When you start adjusting the time, the hour of time will flash and can be set first. You can then proceed to set the time of minute.
- Push the control knob to change between hours and minutes.
- When the correct end time is shown on the LED display, release the control knob **(1)** and wait a few seconds. The end time will flash in the LED display **(5)** for a few seconds, and then the end time will stop flashing.

*NOTE: After a few seconds the LED display will return to showing the time of day, but the timer symbol **(3)**, oven in use symbol **(9)**, and the automatic cooking symbol **(8)** will be activated in the LED display **(5)**.*

- At the end of the countdown time the oven will stop heating, an audible signal will sound and the automatic cooking symbol **(8)** and the oven in use symbol **(9)** will flash. The audible signal will sound for a few minutes before switching off or you can silence it by pressing the control knob **(1)**.
- **IMPORTANT:** Remember to turn the oven function selector knob to the off position ("0") after each use.

The start and end time function (automatic cooking)

This function will allow you to set the time of day that you want the oven to switch off at and how long you want the oven to cook for.

- Place the food that you want to cook inside of the oven and close the door.
- Select an oven function and cooking temperature using the relevant control knobs.
- Press down the control knob **(1)** to toggle through the timer functions.
- When "dur" appears on the LED display you have selected the duration timer.
- Whilst "dur" is flashing, use the control knob **(1)** to adjust the duration (time) you want to cook for. Turn the knob right (plus) to increase the time and left (minus) to decrease the time.
- The default time is 30 minutes. The minimum countdown time that can be set is 1 minute; the maximum countdown time is 240 minutes (4 hours).
- When you start adjusting the time, the hour of time will flash and can be set first. You can then proceed to set the time of minute.
- Push the control knob to change between hours and minutes.
- When the correct time is shown on the LED display, release the control knob **(1)** and wait a few seconds. The whole countdown time will flash in the LED display **(5)** for a few seconds, and then the time will stop flashing. The duration timer will be set.
- **IMMEDIATELY** press the control knob until "end" appears briefly on the LED display before showing a calculated end of cooking time.
- Whilst "end" is flashing, use the control knob **(1)** to adjust the end time. Turn the knob right (plus) to increase the time and left (minus) to decrease the time.
- The default time is the current time of day. The minimum countdown time that can be set is 1 minute; the maximum countdown time is up to 24 hours.
- When you start adjusting the time, the hour of time will flash and can be set first. You can then proceed to set the time of minute.

- Push the control knob to change between hours and minutes.
- When the correct end time is shown on the LED display, release the control knob **(1)** and wait a few seconds. The end time will flash in the LED display **(5)** for a few seconds, and then the end time will stop flashing.

*NOTE: After a few seconds the LED display will return to showing the time of day, but the timer symbol **(3)** and the automatic cooking symbol **(8)** will be activated in the LED display.*

- The appliance will automatically calculate what time of day it needs to switch the oven on at, so that it runs for the cooking time that you set.
- When the oven switches on, the oven in use symbol **(9)** will appear on the LED display, as well as the automatic cooking symbol.
- At the end of the countdown time the oven will stop heating, an audible signal will sound and the automatic cooking symbol **(8)** and the oven in use symbol **(9)** will flash. The audible signal will sound for a few minutes before switching off or you can silence it by pressing the control knob **(1)**.
- **IMPORTANT:** Remember to turn the oven function selector knob to the off position ("0") after each use.

Cancelling the end of cooking, semi-automatic, and automatic timer functions

- You can cancel semi-automatic, end of cooking and automatic timer functions by turning the oven function selector knob **(2)** to the off position ("0").
- You can also use the control knob **(1)** to select a new (start/end/duration) time, or reduce the time to "0:00" to cancel the timer function.
- **IMPORTANT:** If you have cancelled a timer function please ensure that the timer symbol **(3)** and the automatic cooking symbol **(8)** are no longer light on the display.

Cancelling the minute minder function

- You can use the control knob **(1)** to select a new time, or reduce the time to "0:00" to cancel the timer function.
- Press the control knob **(1)** once or until the minute minder symbol **(4)** is displayed.
- Whilst the digits are flashing, use the control knob **(1)** to adjust the time. Turn the knob right (plus) to increase the time and left (minus) to decrease the time.

Adjusting the volume of the audible signal

The volume of the audible signal has 3 levels, low, medium and high. To adjust the volume, you should proceed as follows:-

IMPORTANT: The oven timer/programmer must not be in any form of countdown mode.

- Select the oven light function using the selector knob **(2)**
- Then use the control knob **(1)** to turn the audible volume up or down (plus or minus)
- You can view the level of volume by looking at the audible level symbol **(7)**.
- When you are satisfied you can turn the selector knob back to the off position ("0").

IMPORTANT: The buzzer will be silent between 22:00 and 08:00.

Locking the Oven

- You can manually lock and unlock the oven door (except during Pyrolytic mode) by depressing the control knob **(1)** for 3 seconds.
- The locking symbol **(6)** will flash when the door is locking or unlocking.
- The locking symbol will be light statically when the door is locked.

Selecting a cooking function and temperature

Selecting an oven function

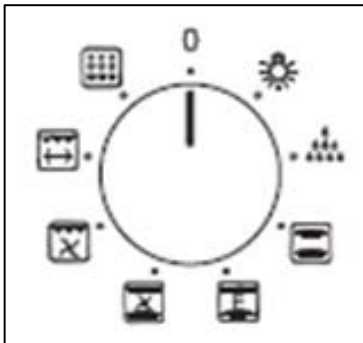

- The oven function selector knob should be used to select the particular mode of cooking that you require. The appliance will utilise different elements within the oven cavity, depending on the oven function that you select.

(Image is for reference only and may differ slightly from your model)

Oven functions



OVEN LIGHT: Separate light control which allows the light to be switched on, even when the oven is switched off.



DEFROST MODE: The fan runs without heat to reduce the defrosting time of frozen foods. The time required to defrost the food will depend on the room temperature, the quantity and type of food. Always check food packaging for the defrosting instructions.

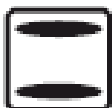

CONVENTIONAL OVEN (top and lower element): This method of cooking provides traditional cooking, with heat from the top and lower elements. This function is suitable for roasting and baking on one shelf only.



ECO-BAKE (top and lower element): This method of cooking provides traditional conventional oven heating, however the cooling fan will only turn on when the oven surfaces reach a high temperature. This saves energy but will increase cooking times.



FAN OVEN: This method of cooking uses the circular element while the heat is distributed by the fan. This results in a faster and more economical cooking process. The fan oven allows food to be cooked simultaneously on different shelves, preventing the transmission of smells and tastes from one dish onto another. **(P650.5SS ONLY)**



BOTTOM ELEMENT AND FAN: This method of cooking uses the bottom element only while the fan is circulating the heat. For delicate dishes and heating pre-cooked food. It is also suitable for sterilising preserving jars. **(P650.5SS ONLY)**



CONVENTIONAL OVEN AND FAN: This method of cooking provides traditional cooking with heat from the top and the lower element, it also utilises the circulation fan. This ensures a fast and even distribution of the heat. Suitable for light and delicate baking, such as pastries. **(BO638.5SS ONLY)**



FAN AND GRILL: This method of cooking utilises the top element in conjunction with the fan, which helps to provide a quick circulation of heat. This function is suitable where quick browning is required and “sealing” the juices in, such as steaks, hamburgers, some vegetables etc.



HALF GRILL: This cooking method is normal grilling, utilising the inner part only of the top element, which directs heat downwards onto the food. Suitable for grilling small portions of bacon, toast, meat etc. **(P650.5SS ONLY)**



FULL GRILL: This method of cooking utilises the inner and outer parts of the top element, which directs heat downwards onto the food. This function is suitable for grilling medium or large portions of sausages, bacon, steaks, fish etc.



PYROLYTIC CLEANING: This function cleans the oven cavity by raising the inner oven temperature to approximately 500°C. The resultant ash deposits can be wiped away with a soft damp cloth once the oven has cooled down.

- Once you have selected your desired oven function, the LED display will show the word “ON” for a few seconds.
- If you have selected an oven function which uses any heating elements, the oven in use symbol **(9)** will be displayed. This symbol will not be displayed when you have selected the oven light or defrost mode.
- After selecting your desired function you can then choose your desired oven temperature (as outlined on the next page) and, if required, a timer function (see *setting and using the oven timer* section).

Thermostat control knob

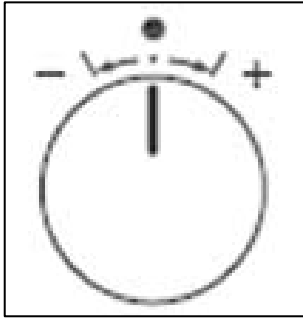

- The control knob sets the required temperature of the oven. It is possible to regulate the temperature within a range of 50 - 250°C.
- The temperature that you select will appear on the LED display.
- Turn the knob right, towards the plus symbol to increase the temperature, and left, towards the minus symbol to decrease the temperature.

NOTE: You can adjust the unit value by turning the control knob once per unit, or you can scroll quickly through the units by holding the control knob to the left or right.

- When selecting an oven function, the default oven temperature will be displayed for that particular cooking mode (see table on next page).
- The temperature appears in the display for about 5 seconds whenever the control knob **(1)** is pressed or when a new function has been selected.
- As soon as the oven starts, the preheating symbol **(7)** will start to flash on the LED display. When the oven has reached the set temperature the preheating symbol light will remain fixed.















You should not place food inside the cavity, until the correct cooking temperature has been reached.

- Turn the oven function selector knob to the "0" (OFF) position to stop any activity within the oven. The display will show "OFF" for a few seconds.

WARNING: ALL OVEN FUNCTIONS (EXCEPT OVEN LIGHT AND DEFROST MODE) WILL START HEATING THE OVEN AS SOON AS SELECTED. THE OVEN FUNCTIONS HAVE PRESET TEMPERATURES. PLEASE SEE THE NEXT PAGE FOR THE COOKING FUNCTION TEMPERATURE TABLE.

IMPORTANT: ALWAYS TURN THE OVEN FUNCTION SELECTOR KNOB TO THE OFF POSITION ("0") AFTER EACH USE.

Cooking function temperature table

N°	MODE	PRESET(°C)	TMIN(°C)	TMAX(°C)	HEATING ELEMENTS (W)	NAME
0						ZERO
1		##	##	##		LIGHT
2		80	50	100	400	WARMING
3		210	50	250	2200	CONVENTIONAL (BAKE)
4		190	50	250	2200	ECO-BAKE
5		210	50	250	1200	LOWER ELEMENT
6		##	##	##		DEFROST
7		190	50	250	1200	LOWER ELEMENT AND FAN
8		190	50	250	2200	CONVENTIONAL AND FAN
9		190	50	250	2300	FAN OVEN
10		230	50	250	2000	GRILL AND FAN
11		230	50	250	2000	HALF GRILL
12		230	50	250	2000	GRILL + TURNSPIT
13		230	50	250	3000	FULL GRILL
14			475		2400	PYRO

Cooking guidelines

- Please refer to the information given on food packaging for guidance on cooking temperatures and times. Once familiar with the performance of your appliance, temperatures and times can be varied to suit personal preference.
- If you are using the fan oven function, then you should follow the information given on the food packaging for this particular mode of cooking.
- You should pre-heat the oven and not place food inside of it until the oven operating light has gone off. You can choose not to pre-heat when using the fan oven mode; however you should extend the cooking time given on the food packaging by at least ten minutes.
- ***IMPORTANT:*** *You should pre-heat the oven if you are baking no matter what oven function you are using.*
- If there is no guidance given on the food packaging specifically for cooking in fan oven mode, you can generally reduce the cooking time and temperature by 10% from the information given for conventional oven cooking.
- Make sure that frozen foods are thoroughly thawed before cooking, unless the instructions on the food packaging advise that you can “cook from frozen”.
- Before cooking, check that any accessories that are not required are removed from the oven.
- Place cooking trays in the centre of the oven and leave gaps between the trays to allow air to circulate.
- Try to open the door as little as possible to view the dishes.
- The oven light will remain on during cooking.

Warnings

- Keep the oven door closed when using ***any*** of the cooking functions, ***including*** the grill functions.
- Do not use aluminium foil to cover the grill pan or heat items wrapped in aluminium foil under the grill. The high reflectivity of the foil could potentially damage the grill element.

- You should also never line the base of your oven with aluminium foil.
- During cooking, never place pans or cookware directly onto the bottom of your oven. They should always be placed on the shelves provided.
- The grill heating element and other internal components of the oven become extremely hot during operation, avoid touching them inadvertently when handling the food which you are grilling.
- **Important:** *Be careful when opening the door, to avoid contact with hot parts of the oven and steam.*
- The enamelled baking tray handle should only be used to reposition the baking and **NOT** for removing it from the oven cavity. When removing the baking tray, you should **ALWAYS** use an oven glove.
- The enamelled baking tray handle should not be left in position when the appliance is switched on.
- **Warning:** *Accessible parts may become hot during use. Young children should be kept well away from the oven when it is in use.*

Shelf positions

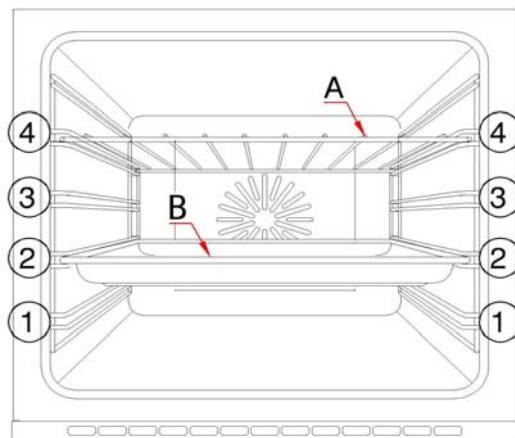

Your oven will come supplied with the following oven furniture:

- (A) Safety shelf (x2)**
- (B) Enamelled baking tray**

- The numbers 1 – 4, indicate the different shelf positions that you can utilise within the oven.
- You should use the shelf position(s) that you find are best suited to your personal cooking preferences.

Cleaning and maintenance



External cleaning operations must only be carried out when the oven is cool and with the appliance disconnected from your mains supply.

- The oven should be thoroughly cleaned before it is operated for the first time. The pyrolytic cleaning process listed below should be followed AT LEAST once a month or more frequently if there have been food spillages inside of the cavity.



Pyrolytic cleaning

- **IMPORTANT: All accessories (including the telescopic runners, if present) must be removed from inside the oven before commencing the pyrolytic cleaning function.**
- **The oven should not be left unattended when the pyrolytic cleaning cycle is in progress.**
- **All major food residues must be removed from the oven before starting this function.**
- Select the pyrolytic cleaning function by turning the oven function selector knob to the cleaning symbol (as shown on page 19/20). The LED display will show "475°" for a few seconds.
- A cleaning period of 90 minutes is automatically set (P1:30 will appear on the LED display **(5)**). This should be sufficient if the pyrolytic cleaning cycle is completed on a weekly basis.

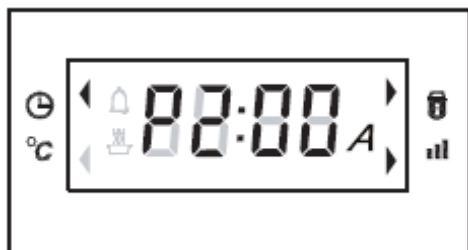

- The length of cleaning cycle can be increased or decreased by using the control knob **(1)**. For example it may be necessary to increase the duration if the oven is heavily soiled. The duration can be changed from 1 hour (min) to 3 hours (max).
- The oven timer functions will still apply to the pyrolytic function. Therefore, the pyrolytic cleaning cycle can be delayed.
- On this oven function the oven temperature will rise to 475°C.
- The oven door will automatically lock during the pyrolytic cycle to ensure user safety. The door lock symbol **(6)** will flash when the door is locking or unlocking, and will be on statically when it is locked.

- During pyrolytic cleaning, the oven light will not switch on.
- At the end of the pyrolytic cycle the LED display will show "P---" and the automatic cooking symbol **(8)** will continue to flash until the selector knob is turned to the "0" (off) position.
- The oven door will remain locked until the oven temperature has fallen below the safety threshold. When the oven has cooled sufficiently the door will unlock.

The door lock symbol (6) will flash when the door is locking or unlocking, will be on statically when it is locked, and will be off when the door is unlocked.

- When the oven has reached a warm temperature, you should use a soft damp cloth to wipe out the resultant ash deposits. For best cleaning results, you should not allow the oven to get completely cold before wiping away the ash deposits.

IMPORTANT: Remember to turn the oven function selector knob to the off position ("0") after each use.

Important: Please note that you should not attempt to open the door until the cleaning cycle has fully completed as outlined above.

General cleaning information

- ***Never*** clean any of the oven surfaces by steam cleaning.
- Outer parts of the oven should only be cleaned with warm soapy water, using either a sponge or soft cloth. No abrasive cleaners should be used.
- We would recommend that an appropriate stainless steel cleaner and polish is regularly used on the stainless steel surfaces of this appliance.
- If you use any form of oven cleaner on your appliance, then you must check with the manufacturer of the cleaner that it is suitable for use on your appliance.

Any damage that is caused to the appliance by a cleaning product will not be fixed by Baumatic free of charge, even if the appliance is within the guarantee period.

Removing the oven door for cleaning

To facilitate the cleaning of the oven/door the door can be removed as follows: -

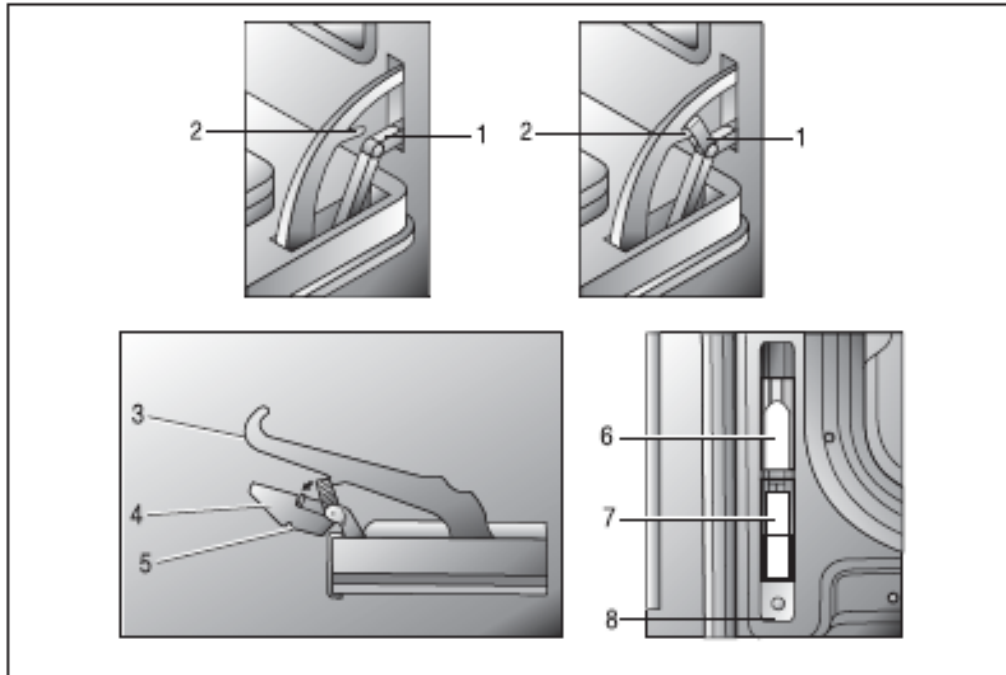

- Open the door completely.
- Lift the lower hinge bracket **(1)** into the upper hinge hook **(2)**.
- Hold the door firmly with two hands on either side, and gently lift the front of the door until it becomes free from the oven cavity.

IMPORTANT: Do not support the door by holding the door handle. Grasp the sides of the door only.

- ***IMPORTANT:*** You should make sure that the door is supported at all times and that you place the door on some padded material whilst cleaning it.
- The oven door and door glass should only be cleaned using a damp cloth and a small amount of detergent. The cloth ***MUST NOT*** have come into contact with any form of cleaning product or chemical previously.
- To refit the door you should follow the steps on the following page:

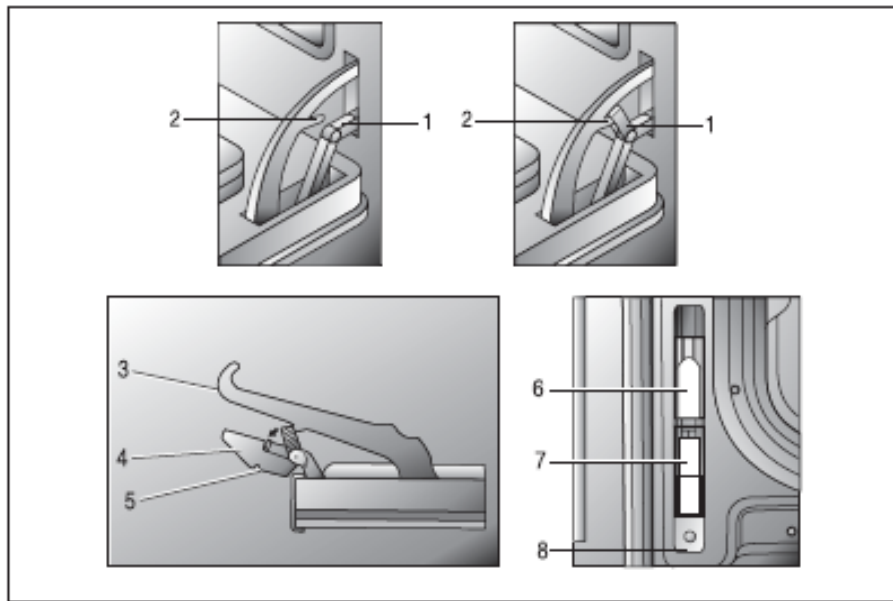

- Insert the upper hinge **(3)** into the upper slots **(6)**
- Insert the lower hinge **(4)** into the lower slots **(7)**
- The lower hinge clip **(5)** must hook onto the lower slot of the oven cavity
- Move the lower hinge bracket **(1)** off the upper hinge hook **(2)** back down into its original position as part of the lower hinge.
- Close and open the door slowly to check that the hinge mechanism is functioning correctly.

IMPORTANT: Keep the door supported at all times to prevent any damage being done while performing this process.



- ***Take care not to dislodge the hinge locking system when removing the door, as the hinge mechanism has a strong spring.***
- ***Do not immerse the door in water at any time.***

Replacing the oven bulb



IMPORTANT: *The oven must be disconnected from your mains supply before you attempt to either remove or replace the oven bulb.*

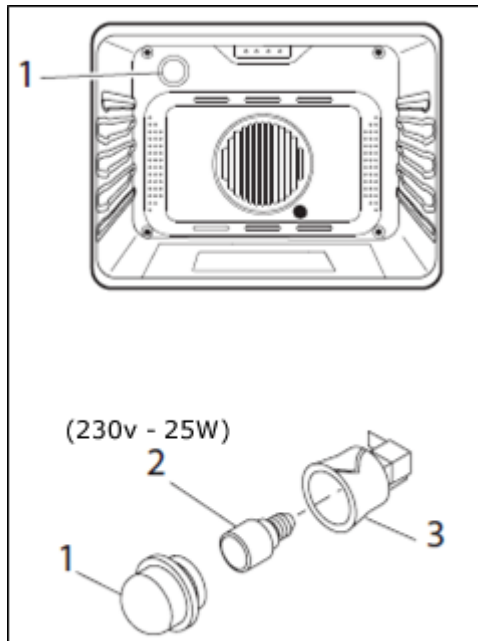

- Remove all oven shelves and the drip tray.
- Remove the light cover **(1)** by unscrewing it anti-clockwise.
- Unscrew the bulb **(2)** anti-clockwise and remove it from its holder **(3)**.
- Replace the bulb with a 25W 300°C, screw type pygmy.
- **Do not** use any other type of bulb.
- Place the lamp cover back into position.

INSTALLATION



The installation must be carried out by a suitably qualified person, in accordance with the current version of the following.

- UK Regulations and Safety Standards or their European Norm Replacements.
- **Building Regulations** (issued by the Department of the Environment).
- **Building Standards** (issued by the Scottish Development Department).
- **IEE Wiring Regulations.**
- **Electricity At Work Regulations.**

Before connecting the appliance, make sure that the supply voltage marked on the rating plate corresponds with your mains supply voltage.

WARNING: THIS APPLIANCE MUST BE EARTHED.

- This appliance should be wired into a 13A (BO638.5SS) / 16A (P650.5SS) double pole switched fused spur outlet, having 3 mm contact separation and placed in an easily accessible position adjacent to the appliance. The spur outlet must still be accessible even when your oven is located in its housing.

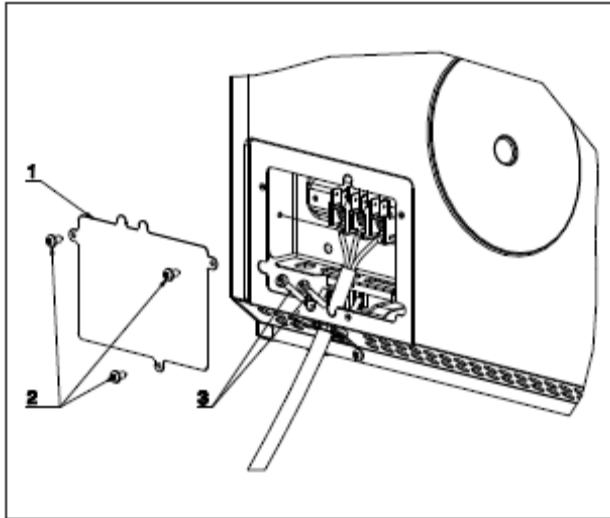
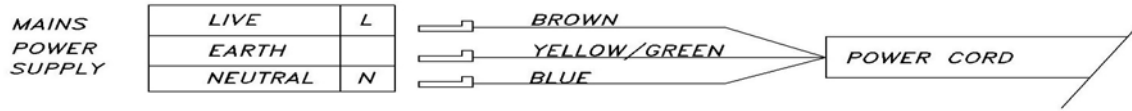

- To connect the oven power cord, loosen and remove the cover **(1)** on the terminal block, in order to gain access to the contacts inside. Make the connection, securing the cords in place with the cable clamp provided **(3)** and then immediately close the terminal block cover again **(2)**.

- If you have to change the oven power cord, the earthing (yellow/green) conductor must always be 10 mm longer than the line conductors.
- Care must be taken to ensure that the temperature of the mains supply cable does not exceed 50°C.
- If the mains supply cable is damaged, then it must be replaced by an appropriate replacement which can be obtained from the Baumatic Spares Department.

Installing the oven into the kitchen cabinet

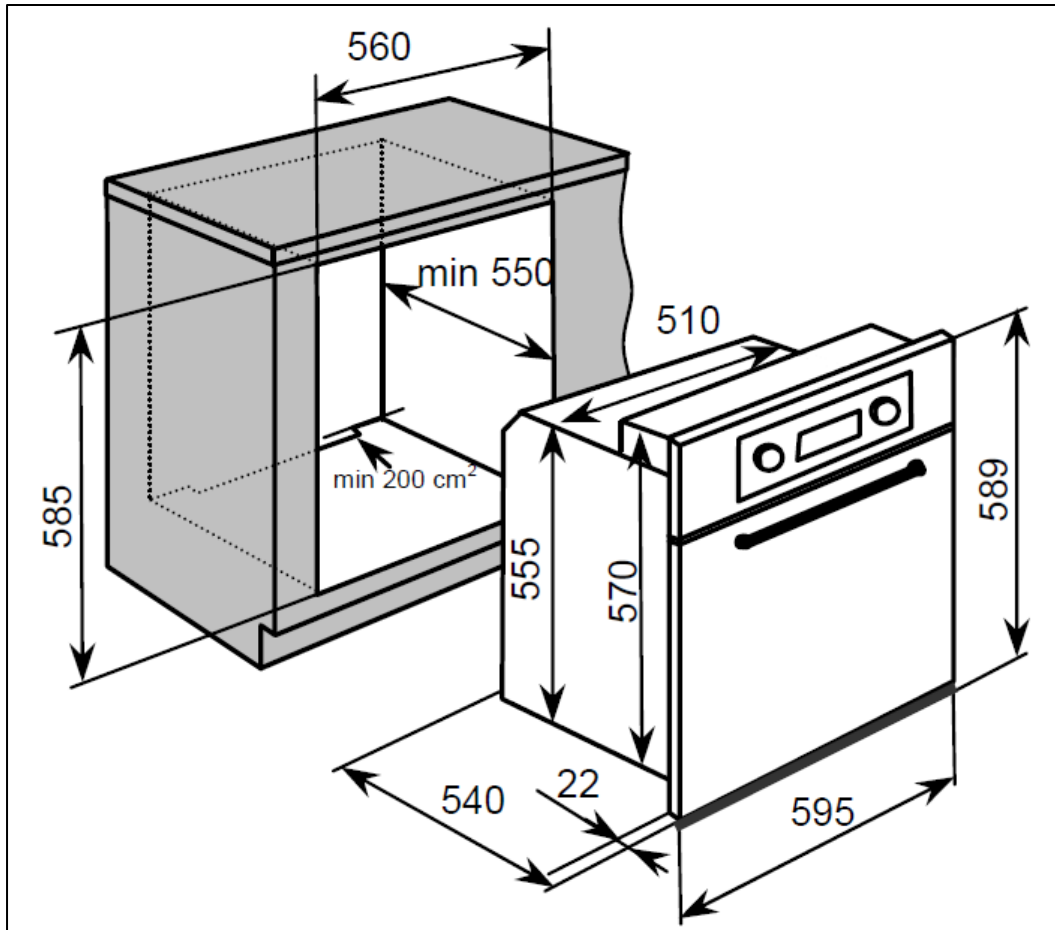

Positioning the appliance

- Ensure that the aperture that you will be fitting the oven into is of the size given in the above diagram.
- The oven must be fitted into an oven housing with the ventilation cut-outs shown in the "Ventilation requirements" section on the next page.
- Ensure that the rear panel of the furniture housing unit has been removed.

Ventilation requirements

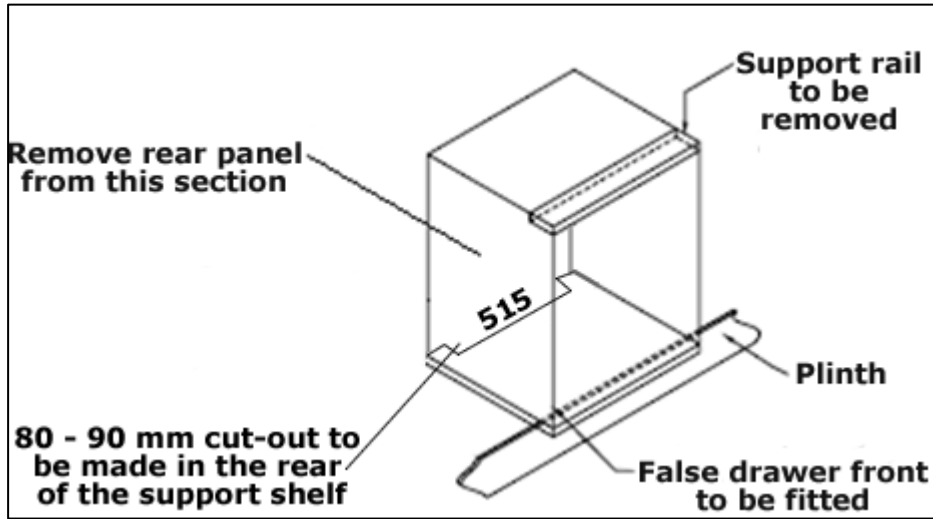

(Figure shows the ventilation and cut-out requirements for the installation of the appliance into a standard kitchen unit).

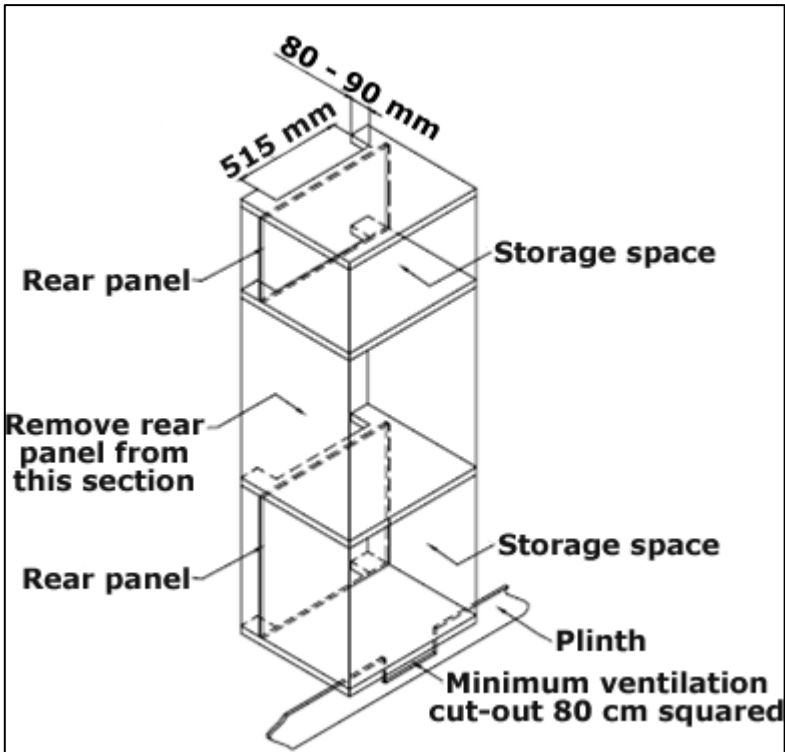

(Figure shows the ventilation and cut-out requirements for the installation of the appliance into a tall housing unit).

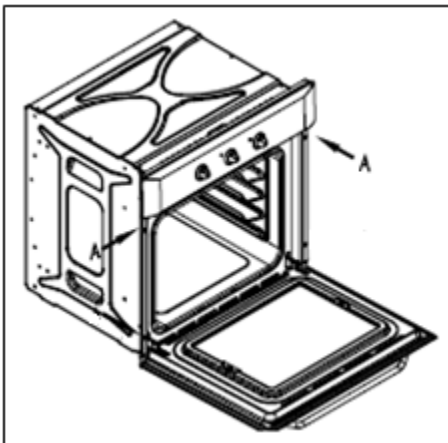

- Ensure that the oven has been securely fixed into the housing unit. The fixing of the oven into the housing is made by using the screws provided. These should be screwed through the oven cabinet and into the housing unit.

My appliance isn't working correctly

- ***The oven isn't coming on.***
 - * Check that the oven is in manual operation mode.
 - * Check that you have selected a cooking function and a cooking temperature.
- ***There appears to be no power to the oven and grill.***
 - * Check that the appliance has been connected to the electrical mains supply correctly.
 - * Check that the mains fuses are in working order.
 - * Check that the operating instructions for setting the time of day and putting the appliance into manual operation mode have been followed.
- ***The grill function works but the main oven does not.***
 - * Check that you have selected the correct cooking function.
- ***The grill and top oven element is not working, or cuts out for long periods of time during use.***
 - * Allow the oven to cool for approximately 2 hours. Once cool, check whether the appliance is again working properly.
- ***My food is not cooking properly.***
 - * Ensure that you are selecting the correct temperature and the correct cooking function for the food that you are cooking. It may be appropriate to adjust your cooking temperature by plus or minus 10°C, to achieve the best cooking results.
- ***My food is not cooking evenly.***
 - * Check that the oven has been installed correctly and is level.
 - * Check that the correct temperatures and shelf positions are being used.

- ***The oven light is not working.***
- * Refer to page 29 and follow the “Replacing the oven bulb” section.
- ***I am getting condensation in my oven.***
- * Steam and condensation is a natural by product of cooking any food with high water content, such as frozen food, chicken etc.
- * You may get condensation in the oven cavity and forming between the oven door glasses. This is not necessarily a sign that the oven is not working correctly.
- * Do not leave food in the oven to cool after it has been cooked and the oven has been switched off.
- * Use a covered container, where practical, when cooking to reduce the amount of condensation that forms.

Error codes:

If an abnormal condition is detected by the appliance for more than one minute then a failure occurs. The oven will disable itself and display an error code. The error code will show the letter “E” followed by a number, for example “E1”, and the oven will also emit a warning signal. If your appliance displays an error code you should take note of the error code, disconnect your appliance from the mains supply, and then contact Customer Care, reporting the error code.



IMPORTANT: If your appliance appears not to be operating correctly, then you should disconnect it from your mains supply and then contact Baumatic Customer Care on telephone number (0118) 933 6911.

DO NOT ATTEMPT TO REPAIR THE APPLIANCE YOURSELF.

Please note that if an engineer is asked to attend whilst the product is under guarantee and finds that the problem is not the result of an appliance fault, then you may be liable for the cost of the call out charge.

The appliance must be accessible for the engineer to perform any necessary repair. If your appliance is installed in such a way that an engineer is concerned that damage will be caused to the appliance or your kitchen, then he will not complete a repair.

This includes situations where appliances have been tiled in, sealed in with sealant, have wooden obstructions placed in front of the appliance, like plinths. Or any installation other than the one specified by Baumatic Ltd. has been completed.

Please refer to the conditions of guarantee that appear on the warranty card that you receive with the appliance.

IMPORTANT: Baumatic Ltd. operates a policy of continuous improvement and reserves the right to adjust and modify its products without prior notification.



United Kingdom

Baumatic Ltd.,
Baumatic Buildings,
6 Bennet Road,
Reading, Berkshire
RG2 0QX
United Kingdom

Sales Telephone

(0118) 933 6900

Sales Fax

(0118) 931 0035

Customer Care Telephone

(0118) 933 6911

Customer Care Fax

(0118) 986 9124

Spares Telephone

(01235) 437244

Advice Line Telephone

(0118) 933 6933

E-mail:

sales@baumatic.co.uk
customercare@baumatic.co.uk
spares@baumatic.co.uk
technical@baumatic.co.uk

Website:

www.baumatic.co.uk

Republic of Ireland

Service Telephone

1-890 812 724

Spares Telephone

091 756 771

Czech Republic

Baumatic CR spol s.r.o.
Lípová 665
460 01 Liberec 4
Czech Republic

+420 483 577 200

www.baumatic.cz

Slovakia

Baumatic Slovakia, s.r.o.
Panenská 34
811 03 Bratislava - Staré Mesto
Slovakia

+421 255 640 618

www.baumatic.sk

Germany

Baumatic Gmbh
Lilienthalstrasse 1
320 52 Herford
Deutschland

+49 5221 694 99-0

www.baumatic.de

Italy

Baumatic Italia S.R.L.
Via Galvani N.3
35011 Campodarsego (PD)

+3904 9920 2297

www.baumatic.it

Holland

Baumatic Benelux B.V.
Grindzuigerstraat 22
1333 MS ALMERE
Nederland

+3136 549 1555

www.baumatic.nl

