



**LUCCI
AIRFUSION RADAR
DC CEILING FAN**

- **INSTALLATION**
- **OPERATION**
- **MAINTENANCE**
- **WARRANTY INFORMATION**

CAUTION
**READ INSTRUCTIONS CAREFULLY FOR SAFE
INSTALLATION AND FAN OPERATION.**

CONTENTS

Page 2	Important information Safety precautions
Page 3	Parts list
Page 4-7	Installing the fan
Page 7-10	Using your ceiling fan
Page 11	Care & cleaning Warranty service Wobble Normal wear and tear Bump in the night Fan light
Page 12	Trouble shooting checklist
Page 13	Notes to installer Technical information
Page 13-15	Warranty conditions



IMPORTANT INFORMATION – PLEASE READ PRIOR TO INSTALLATION

Congratulations on purchasing the latest in energy saving ceiling fans. This Airfusion Radar fan runs on DC (direct current) power which gives it the benefit of being super energy efficient whilst still maintaining high volume air-movement and silent operation.

Energy saving - The DC motor is the latest technology in fan design. Its highly efficient motor saves up to 65% more energy than ceiling fans with traditional AC motors.

Silent operation – This DC fan motor is programmed with a stabilized current which efficiently reduces motor noise.

Low operating temperature – The DC power is managed effectively which brings down the motor operating temperature to less than 50degs. This results in a much cooler motor than a standard AC fan and increases the longevity of the motor.

Regular AC ceiling fans usually come with only 3 speeds, this Airfusion Radar DC fan comes complete with a 6 speed remote, which gives a greater choice of comfort levels.

SAFETY PRECAUTIONS

- 1) This ceiling fan is NOT intended for use by persons (including children) with reduced physical, sensory or mental capabilities, or lack of experience and knowledge, unless they have been given supervision or instruction concerning use of the appliance by a person responsible for their safety.
- 2) Children should be supervised to ensure that they do not play with the appliance.
- 3) An all-pole disconnection switch must be incorporated in the fixed wiring in accordance with the wiring rules.
- 4) Do not dispose of electrical appliances as unsorted municipal waste, use separate collection facilities. Contact your local government for information regarding the collection systems available. If electrical appliances are disposed of in landfills or dumps, hazardous substances can leak into the groundwater and get into the food chain, damaging your health and well-being.
- 5) The structure to which the fan is to be mounted must be capable of supporting a weight of 30kg.
- 6) The fan should be mounted so that the blades are at least **2.3** metres above the floor for Europe.
- 7) The fan should be mounted so that the blades are at least **2.1** metres above the floor for Australia.
- 8) This fan is suitable for indoor use only. Mounting the fan in a situation where it is subject to water or moisture is dangerous.
- 9) Only an authorized electrician should execute the installation.



Airfusion Radar Installation Instructions

PARTS LIST

Unpack your ceiling fan carefully. Remove all parts and hardware. Place the fan motor on a cloth or soft surface to avoid damaging the finish.

- Do not lay the motor housing on its side – the decorative housing may become bent or damaged.
- Verify that all parts are present before starting assembly.
- Check the packaging carefully for missing parts.

Examine all parts. You should have the following:

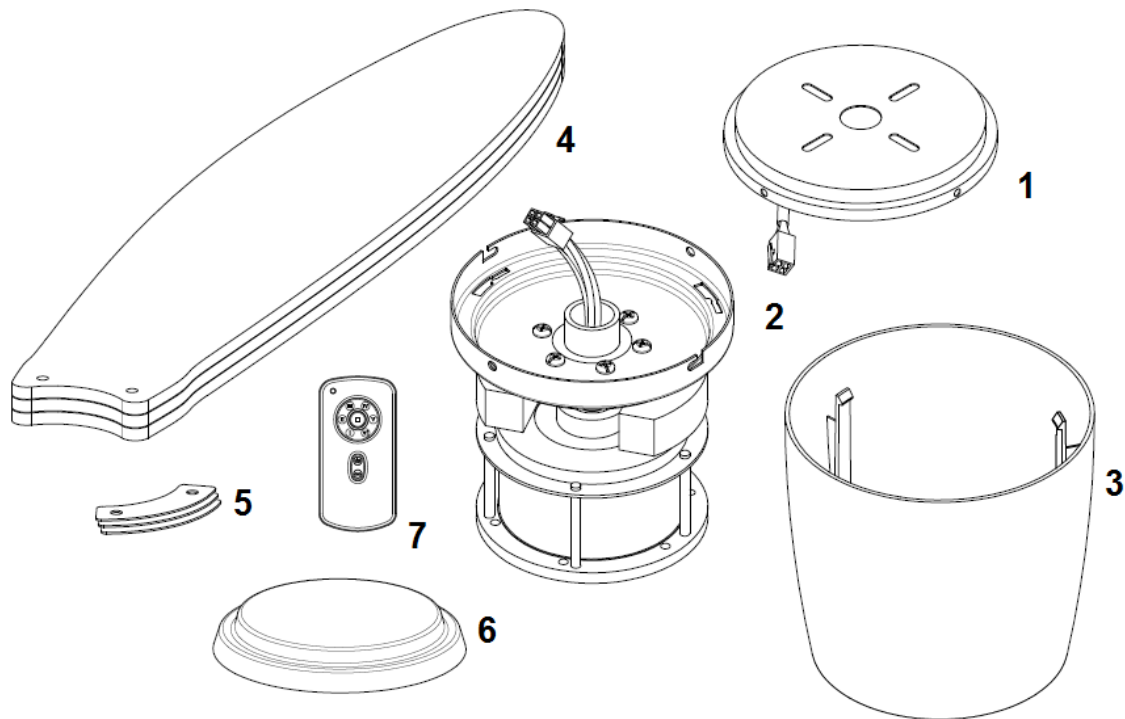

Fig. 1

- | | | | |
|---|--|----|---|
| 1 | Mounting bracket x 1 | 7 | Remote transmitter with holder x 1 set |
| 2 | Fan assembly with hanging plate, receiver, and motor x 1 | 8 | Extra Motor screws x 1 (not shown) |
| 3 | Motor housing x 1 | 9 | Wooden screw x 4 (not shown) |
| 4 | Blade x 3 | 10 | Screw for remote holder x 2 (not shown) |
| 5 | Blade bracket kit x 3 | 11 | 12V Battery for remote x 1 (not shown) |
| 6 | Bottom cover x 1 | | |



INSTALLING THE FAN

TOOLS REQUIRED:

- Phillips / Flat head screwdriver
- Pair of pliers
- Adjustable spanner
- Step ladder
- Wire cutter
- Wiring, supply cable as required by local provincial and national wiring codes and regulations.

INSTALLING THE MOUNTING BRACKET

The ceiling fan must be installed in a location so that the blades are spaced 300mm from the tip of the blade to the nearest objects or walls.

Secure the hanging bracket to the ceiling joist or structure that is capable of carrying a load of at least 30kg, with two long screws provided. Ensure at least 30mm of the screw is threaded into the support.

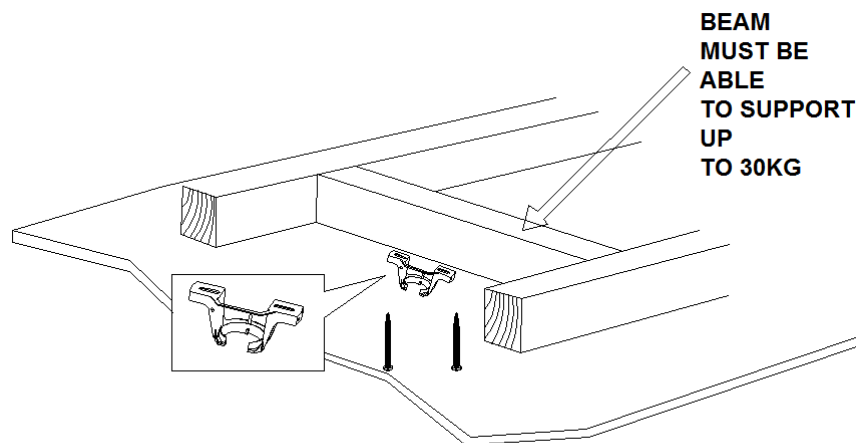

Fig. 2

NOTE: THIS PICTURE IS FOR REPRESENTATION ONLY AND DOES NOT REPRESENT THE ACTUAL BRACKET.

NOTE: The bracket screws provided are for use with wooden structures only. For structures other than wood, the appropriate screw type MUST be used.

ANGLED CEILING INSTALLATION

This fan hanging system **DOES NOT** support a degree angled ceiling installation.



Airfusion Radar Installation Instructions

HANGING THE FAN MOTOR ASSEMBLY

- Lift the fan assembly to the mounting bracket (1) and let the J-hook of the mounting bracket (4) go through the hole of the hanging plate and hang up the fan assembly (3). Fig. 3
- Connect the male and female connector together (2). Fig. 3
- Complete the electrical wiring using the diagram below (Figure. 4).

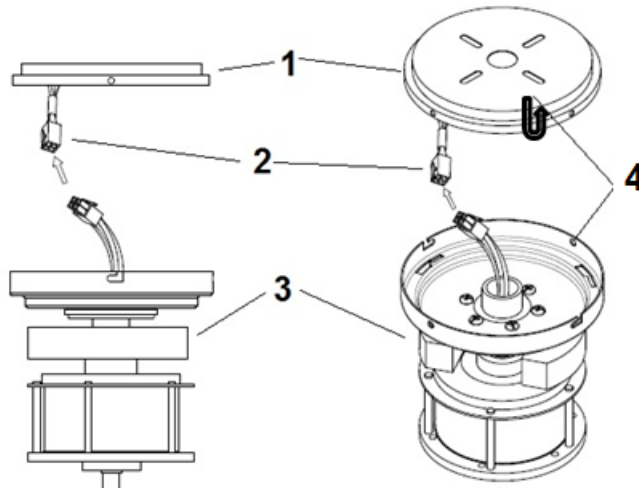

Fig. 3

PREPARE AND COMPLETE THE ELECTRICAL WIRING --- WIRING DIAGRAM (Fig. 4)

WARNING: FOR YOUR SAFETY, ALL ELECTRICAL CONNECTIONS MUST BE UNDERTAKEN BY A LICENSED ELECTRICIAN.

NOTE: AN ADDITIONAL ALL POLE DISCONNECTION SWITCH MUST BE INCLUDED IN THE FIXED WIRING.

NOTE: IF THERE ARE TWO OR MORE DC CEILING FANS INSTALLED IN THE ONE LOCATION, AN ISOLATION SWITCH IS REQUIRED FOR EACH CEILING FAN. THIS IS REQUIRED WHEN PROGRAMMING THE REMOTE AND RECEIVER TO PAIR TOGETHER.

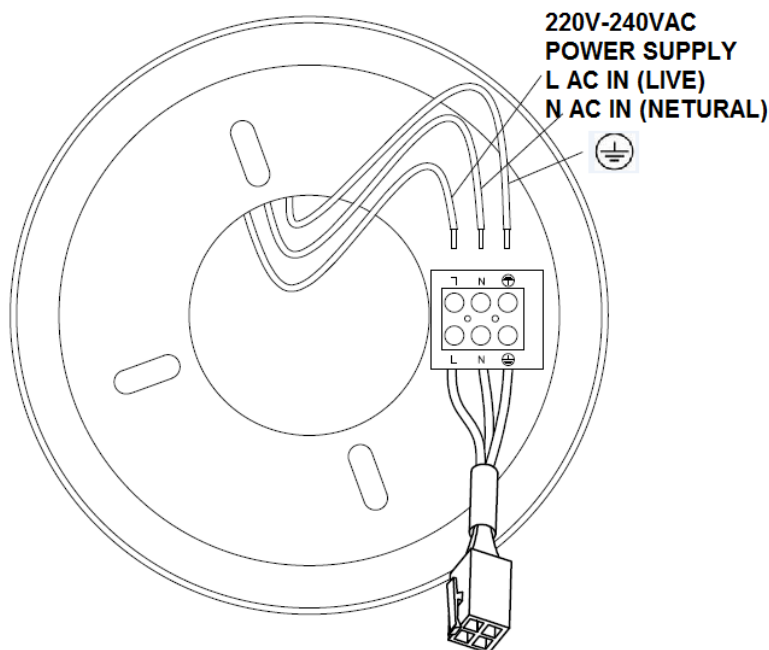

Fig. 4



INSTALL THE CANOPY COVER

- Loosen 2 screws (2) from the mounting bracket. Fig. 5
- Loosen 2 screws (1) by half thread from the mounting bracket. Fig. 5
- Lift the hanging plate of the fan assembly up to the mounting bracket and let the L-shape slot on the hanging plate go through the screws (1) on the mounting bracket. Turn the hanging plate until it locks in place at the end section of the L-shape slot and secure it by tightening the two screws (2). Avoid damaging the electrical wiring prepared previously.
- Finally attach the motor housing to the hanging plate and secure it by pushing the hooks (3) into the slot holes and turn it anti clockwise.

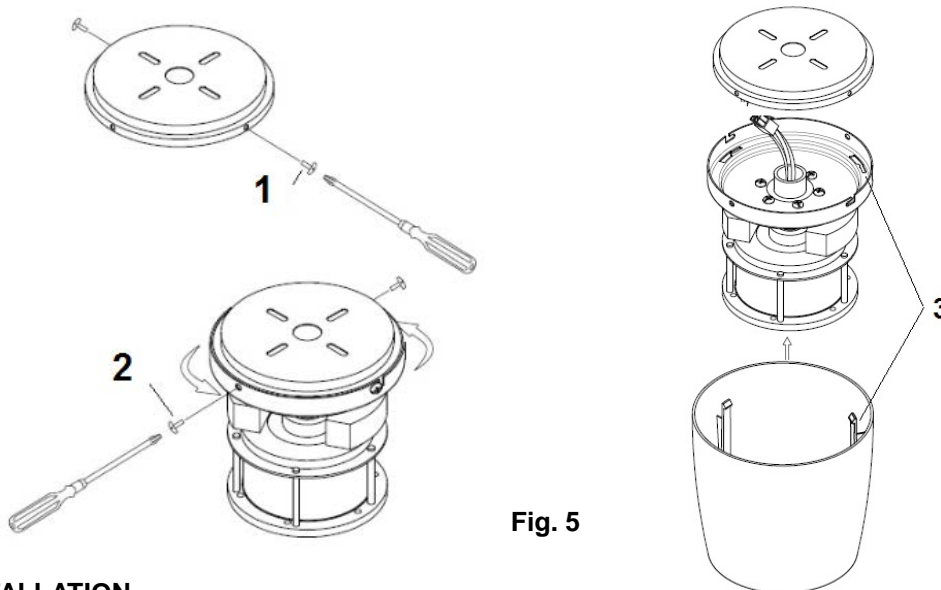

Fig. 5

BLADE INSTALLATION

- Insert the blade screws through the blade assembly in the following order - bracket kit (2) and blade (1). Attach the blade assembly to the motor and secure it by tightening the 2 screws (3). Fig. 6
- Repeat to install the other blades.
- Finally install the bottom cover (4) to the shaft of the motor by rotating it clockwise.

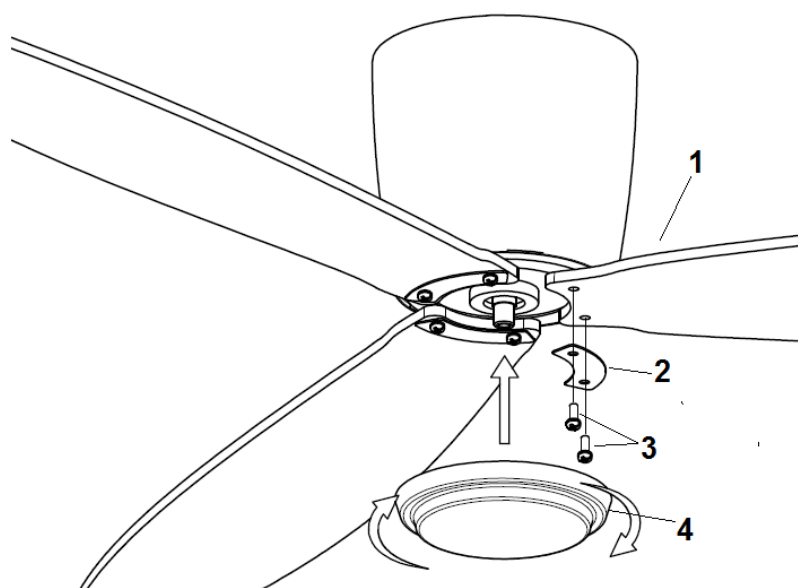

Fig. 6



LIGHT KIT Installation (Light kit - optional)

NOTE: The light kit must be installed by a licensed electrician.

NOTE: The light kit is available for selected ceiling fan models and as an optional light kit.

1. Remove the bottom cover from the shaft.
2. Remove the shrinkable tube from the light wires connector.
3. For light kit installation, please refer to the light kit installation user guide.

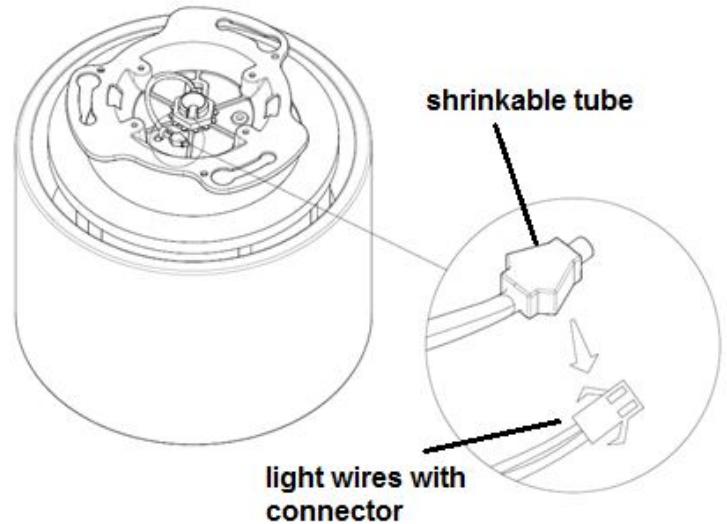

Fig. 7

USING YOUR CEILING FAN

Pairing Transmitter and Receiver – when 2 or more DC ceiling fans are installed in one location

When two or more ceiling fans are located near each other, you may desire to have the receiver/transmitter for each fan set to a different code so that the operation of one fan does not affect the operation of the other fan/s.

The DIP switches for the transmitter (remote hand piece) are located in the battery compartment of the transmitter. Configuring the DIP switches will allow a unique transmission code assigned to each ceiling fan.

NOTE: Ensure that you have installed an all - pole disconnection switch in the fixed wiring for each fan, when using DIP code function.

NOTE: Ensure power to the Receiver is **ON** prior to pairing the transmitter with the receiver.

Transmitter/Receiver pairing for ceiling fan 1:

- Turn off both ceiling fans 1 and 2 via the mains supply to the receiver.
- Slide the cover of the battery compartment of the transmitter to access the DIP switches. This will be transmitter 1.
- Change the position of the DIP switches in the remote transmitter 1, so that it will be different to transmitter 2. Fig. 8
- Install the 12V DC battery in the compartment. Please make sure the polarity of the battery is correct.
- Turn on the power to receiver 1. Keep the power OFF to receiver 2. (Each ceiling fan must have its own isolation switch, so that only the ceiling fan that needs to be paired with the transmitter will be ON).
- Press and hold the SET button of **transmitter 1** for 6 seconds within 60 seconds of switching the power to the receiver of ceiling fan 1.
- Now the transmitter should be paired with the receiver of ceiling fan 1. Turn ON/OFF or change the speed of ceiling fan 1 by the transmitter to check the operation.



Airfusion Radar Installation Instructions

Setting DC Ceiling fan 2:

- Turn off both ceiling fans 1 and 2 via the mains supply to the receiver.
- Slide the cover of the battery compartment of the transmitter to access the DIP switches. This will be transmitter 2.
- Change the position of the DIP switches in the remote transmitter 2, so that it will be different to transmitter 1. Fig. 8
- Install the 12V DC battery in the compartment. Please make sure the polarity of the battery is correct.
- Turn on the power to receiver 2. Keep the power OFF to receiver 1. (Each ceiling fan must have its own isolation switch, so that only the ceiling fan that needs to be paired with the transmitter will be ON).
- Press and hold the SET button of **transmitter 2** for 6 seconds within 60 seconds of switching the power to the receiver of ceiling fan 2.
- Now the transmitter should be paired with the receiver of ceiling fan 2. Turn ON/OFF or change the speed of the ceiling fan 2 by the transmitter to check operation.

Note: The pairing of Transmitter and Receiver is not required if only one ceiling fan is installed. When more than two ceiling fans are installed near each other, please refer to the instruction above.

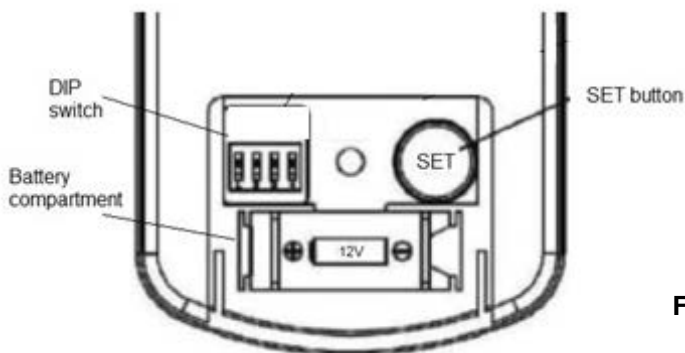
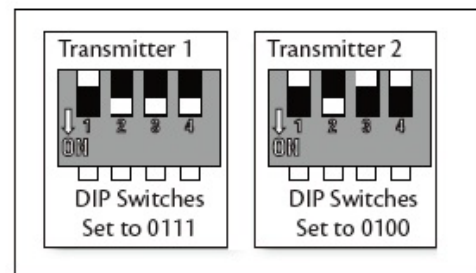

Fig. 8



Remote Control Buttons

① - FAN SPEED CONTROL BUTTON:

There are 6 available speeds. ① button is for the lowest speed, and ⑥ button is for the fastest speed.

NOTE: WHEN YOU TURN ON THE FAN FOR THE FIRST TIME OR SWITCH THE MAIN POWER TO THE CONTROLLER, YOU NEED TO START THE FAN ON HIGH “⑥” SPEED FIRST AND THEN CHOOSE A LOWER SPEED. A 5-10 SECONDS IS REQUIRED TO ALLOW THE DC FAN TO RESPOND TO THE REMOTE EACH SPEED OR FAN DIRECTION SELECTIONS, AS DC FANS INCORPORATE A SENSOR CONTROL WHICH CONTROLS THE POWER TO THE MOTOR.

Fig. 9

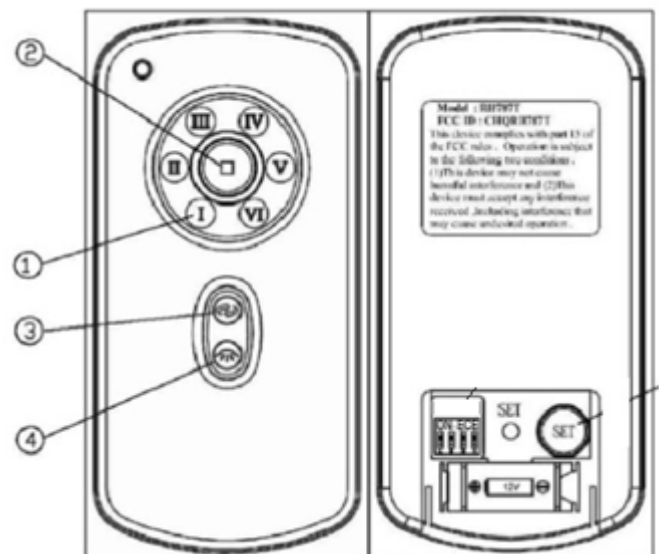

Airfusion Radar Installation Instructions

② - FAN OFF BUTTON:

Press the button to turn the fan off.

③ - REVERSE FUNCTION BUTTON:

Press the button to activate the reverse running function. The fan must be operating to activate the reverse function.

④ - LIGHT CONTROL BUTTON:

Press the button to turn on/off the light.

THE RECEIVER PROVIDES THE FOLLOWING LEVEL OF PROTECTION:

- Lock position: the receiver has a built in safety feature to protect against obstruction during operation. The motor will be locked from operation and will disconnect from power after 30 seconds of interruption. Please remove obstacles before re-starting. To reset, simply turn off the power supply to the fan motor and re-start.
- Over 80W protection: when the receiver detects power consumption which is greater than 80W, the receiver power will be stopped and operation will immediately discontinue. Turn the receiver power on after 5 seconds to restart the fan.

REPAIRING THE FAN RECEIVER & REMOTE PAIRING

Should the remote and receiver lose control after installation or during use, the pairing of the remote and the receiver must be repaired. Below are the operating symptoms and method to repair the pairing of the DC ceiling fan remote and receiver.

Issues:

- Loss of control - Fan is only running at high speed after installation
- Loss of control - No reverse function after installation
- Loss of control - Remote cannot communicate with receiver

Solution:

If the fan runs at the highest speed continuously, it means the wiring of the installation is correct. When the fan operates on high speed only or fails to operate in reverse function or any other command/s, it is recommended to repair the communication pairing of the remote and receiver. Please follow the steps below:

- Remove the battery cover of the remote, check the 434 MHz sticker area, make sure the battery is installed correctly and the red LED light indicator will be flashing, it means the remote function is okay.



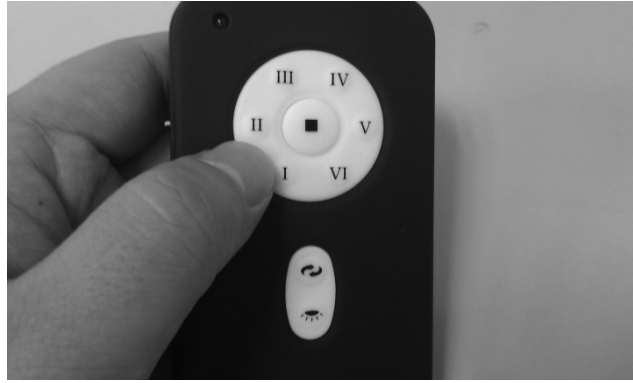

- B. Turn off the main supply to receiver more than 30 seconds and turn on the main supply to receiver again. Press and hold the SET button of **remote** for 6 seconds within 60 seconds of turning turn the power to the receiver.

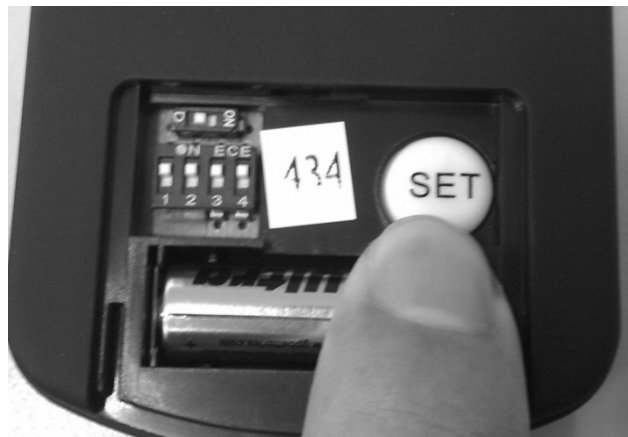

- C. Press the buttons on the remote to run the fan. In general, performing point A, B, and C should repair the remote and receiver, and will allow full control of the fan. If not, please do the next step.
- D. The DIP switches of fans are set up at the factory in all up. And we can change DIP switch at any location in 16 options. (Ex. up-up-down-down).



- E. Please repeat the (A)-(C) steps to check the function.

If the issues still persist after following point (A) to (D) and there is still no control, then please contact the local retailer for a new remote or transmitter.



NOTE: For your safety, a new receiver must be installed by a licensed electrician.

NOTE: While repairing the DC ceiling fan remote and receiver is in process, the fan operates at highest speed with REVERSE mode automatically for 90 seconds and then operates with FORWARD mode for 90 seconds. During the paring process, do not press any key on the remote.

CARE & CLEANING

- Periodic cleaning of your ceiling fan is the only maintenance required. Use a soft brush or lint free cloth to avoid scratching the paint/plated finish. Please make sure the fan is not operating when cleaning.
- Do not use water when cleaning your ceiling fan. It could damage the motor or the blades and create the possibility of an electrical shock.

WARRANTY SERVICE

The manufacturer warranty covers actual faults that may develop, but NOT minor complaints, e.g. noise from motor run—ALL ELECTRIC MOTORS ARE AUDIBLE TO SOME EXTENT.

AUSTRALIAN/NEW ZEALAND CUSTOMERS – Please refer to the separate WARRANTY STATEMENT.

EUROPEAN CUSTOMER – Please contact the retail outlet where the fan was purchased for a warranty service.

WOBBLE

- Ceiling fans tend to move during operation due to the fact that they are not generally rigidly mounted. If they were, they could generate excessive ceiling vibration and stress on their mountings.
- Movement of a couple of centimetres is quite acceptable and does not suggest that the fan will fall down.
- Ceiling fans are mounted very securely on steel brackets with rubber cushioning or with ball-joints to allow free movement.
- Please note that not all ceiling fans are the same, even in the same model—some may move more or less than others.

NORMAL WEAR AND TEAR

Threaded components working slightly loose or blade carriers even slightly bent due to vigorous cleaning or bumping can cause extra wobble and noise. THIS IS NOT COVERED UNDER WARRANTY, but a little care and maintenance can reduce or prevent this problem.

BUMP IN THE NIGHT

This is the biggest cause for service calls, which are outside the manufacturer's warranty. If a fan has a fault, it will be noticeable at all times. Naturally, when everything is quiet at night, you will be more inclined to hear small noises, which may not be noticeable at other times. Even slight power fluctuations and mains frequency signals superimposed in your electricity supply for off-peak hot water control may cause a change in fan motor noise. This is normal.

FAN LIGHT

Except for actual faults in the manufacture, which are extremely rare, FAN LIGHTS AND GLOBES ARE NOT COVERED UNDER YOUR FAN WARRANTY. Noises and vibration etc. are often more accentuated when a fan light is fitted. For instance a fan light glass that has not been tightened or has worked loose can cause a rattle. Again, care and maintenance will reduce this. Glass of all kinds is warranty to the retailers' door and subject to the retailer checking it on delivery.



TROUBLE SHOOTING CHECKLIST

Always check the “Trouble Shooting Checklist” included in this booklet before calling for service. Unnecessary calls are inconvenient for all and can attract a service charge.

WARNING: THE CEILING FAN MUST BE SWITCHED OFF BEFORE TROUBLE SHOOTING IS PERFORMED.

TROUBLE	PROBABLE CAUSES	SUGGESTED REMEDY
1. Fan will not start (Warning: The ceiling fan must be switched OFF and the assistance of a licensed electrician may be required).	A. Fuse or circuit breaker blown.	Check main and branch circuit fuses or circuit breakers.
	B. Loose power connections to the fan. (Normally occur during installation.)	Check power connections to fan. Must be performed by a licensed electrician.
	C. No response from the remote transmitter.	- Battery is low. Replace batteries. - Check if correct remote transmitter is paired with the receiver.
	D. Switch the Fan ON via the mains switch.	Check if there is power to the fan.
2. Fan Wobbles (Refer to Wobble section of the manual for further information).	A. Fan blades are not horizontal to ceiling.	Refer to “wobbling fixing” section of manual. - The blade may require adjustment at the blade mounting screws; - The blade is out of shape, thus causing wobbling. New blades set will require to be replaced. Contact retailer for further details.
	B. Blade screws are loose.	Make sure all screws are securely fastened.
	C. Blade/s are out of shape.	Remove blade and lay on a flat surface to check if blades are out-of-shape. Contact retailer for further details.
3. Fan sounds noisy.	A. Top canopy touching ceiling.	Lower canopy from ceiling to ensure minimum 3 mm clearance.
	B. Loose fan blade screws.	Re-tighten all screws on fan blades but never over-tighten.
	C. Ceiling fan not secured against ceiling.	Re-tighten all screws in the hanging bracket or plate.
	D. Incorrect speed controller.	Change the controller to the one supplied. (Must be performed by a licensed electrician.)
4. Mechanical Noise.	A. Allow at least for 8 hours settling-in period.	
5. Light will not turn ON (Optional light kit ONLY).	The globe/lamp has failed.	Replace globe/lamp.

NOTES TO INSTALLER

- All electric motors, including fans make some noise and may feel hot if touched—this is not a fault.
- Some fans wobble more than others—even in the same model.
- Fan lights can rattle, but are not covered under warranty.
- Fan wall controllers make a slight buzz and get warm especially on lower settings. These occurrences are not covered by the manufacturer’s warranty.

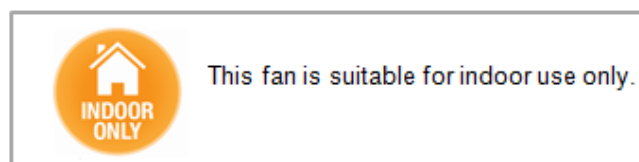

TECHNICAL INFORMATION

AIRFUSION RADAR SERIES DC FAN models	Rated Voltage	Rated power (motor)	Battery for remote
RADAR 52" FAN	220-240VAC	35W	1 x 12V 23AE

WARRANTY CONDITIONS

IN AUSTRALIA / NEW ZEALAND – Please refer to the separated WARRANTY STATEMENT.

IN EUROPE – If you are a European customer please contact the retail outlet where the fan was purchased for a warranty service.

This product is guaranteed against electrical defects in material or manufacturing workmanship for faults when under normal domestic/residential conditions for a certain period of time from the date of purchase. This warranty covers parts and labour costs for the motor subject to the following conditions:

1. Installation being performed by a qualified licensed electrician.

This warranty will not apply if the ceiling fan is installed by anyone other than a licensed electrician. Problems arising from incorrect installation are not covered by warranty. The cost of repairs and/or service calls where the defect is due to the installation and not due to faulty material or workmanship, in accordance with wholesaler and their authorized agent, will be payable at time of repair.

2. The correct controller being fitted to the fan.

Only use the controller supplied with the fan or a genuine replacement. Using solid-state dimmer type or non-genuine controllers will void the warranty. Use of non-genuine controllers may cause the fan to operate with a loud hum and at altered speeds. Where controllers are supplied complete with light switch – do not use this switch to operate the fan. Fans connected using this switch to turn the fan on/off, will not be covered by warranty.

3. Repair work being carried out by a licensed electrician only after authorization by the wholesaler or their authorized agent to complete the repair and is subject to the supply of dated proof of purchase and installing electricians details.
4. The exclusion from warranty of any changes to ceiling fan blades or motor, plated and/or painted finishes due to climatic conditions (moisture, salt air etc.) or after 6 months from the date of purchase or other circumstances deemed to be beyond the control of wholesaler or their authorized agents.
5. The warranty service does not cover:
 - a. Transportation and in-transit insurance costs, if the product or parts thereof have to be returned for repair or replacement to the retailer or their authorized agent.
 - b. Repair of defects caused by accident, fire, misuse, alterations modification, negligence, incorrect or incomplete installation/operation, any unauthorized person attempting to repair the ceiling fan, or acts of God.
 - c. Claims or damage to furniture, carpet, wall, ceiling foundations or any other consequential loss either direct or indirectly resulting from a faulty ceiling fan.
6. Except in the case of pre-packed integrated light models, light fittings attached to the fan are not covered by this



warranty. Where the fan is pre-packed complete with a light, the light fitting will be covered by warranty to electrical defect. Tarnishing caused by climatic conditions and breakage of glasses is not covered by warranty. Globes/lamps are also not covered by warranty. All light fittings attached to the fan must be installed by a licensed electrician ensuring such attachments are complete and do not affect the fan's performance. Light fittings will often accentuate noises and vibrations, which can be traced to loose glass or fittings and are not covered by warranty. Broken glass as supplied in the pre-packed light complete models is not considered an item requiring a warranty service call. Notification within 48 hours of installation is required where glasses have found to be broken on unpacking.

7. The warranty applies to actual faults which may develop. Minor running noises are not covered. All electrical motors have some audible noise. Allow at least eight hours of operation to allow the bearings to properly seat. The fan, especially when set on low, may feel warm to touch – this is not a fault. If excessive heat is generated a service call may be required. Fan noises can vary due to slight power fluctuations and mains frequency signals for off-peak controlled appliances. These changes are most noticeable in the quiet of night, mains frequency signals which come across as an intermittent hum (mostly at night) are out of control of the manufacturer. In these cases your electricity provider should be contacted, or an electrician to fit a suitable noise filter.
8. Threaded components such as blade nuts can work slightly loose during normal operation. These should be tightened regularly to ensure the fan doesn't develop operation noises. If noises do develop, check this aspect before requesting service. This is not covered by warranty.
9. Minor variation of speed may be evident between different fans, even in the same model and is not a product fault and not covered by warranty.
10. Blades are not covered by warranty against defect in material. The replacement of the blades is not covered by the in home warranty service call, notification within 48 hours of installation is required where blades have found to be broken on unpacking, contact the retailer or their authorized agent who will send you a new set of blades. Each blade set is balanced so it is important to replace all blades. Blades affected by climatic conditions and by maintenance are not covered by this warranty.

This warranty applies only to Australian states; its mainland territories and New Zealand. The benefits of this warranty are in addition to any benefits offered under state or territory law.

For under warranty service, contact the hotline number in this booklet and advise: the model number and style, the nature of the fault, date and place of purchase. Service cannot be arranged without this information.

Prior to requesting service, please consult the trouble-shooting checklist that is printed in this manual.

- All electric motors, including fans, make some noise and may feel hot to touch – this is not a fault.
- Some fans wobble more than others – even in the same model.
- Blades are weighed to be within tolerance to minimize wobbling. In multiple installations, do not mix blades from fans.
- Fanlights can rattle and are not covered by warranty.
- Finish to the fan, including blades and light complete models, are covered by 2 years warranty.
- Blade and glass replacements are not covered by in home servicing.

