



**Distributed Audio Panel
ACC-25/50DA &
ACC-25/50DAZS
Instruction Manual**

Fire Alarm System Limitations

While a fire alarm system may lower insurance rates, it is not a substitute for fire insurance!

An automatic fire alarm system—typically made up of smoke detectors, heat detectors, manual pull stations, audible warning devices, and a fire alarm control panel with remote notification capability—can provide early warning of a developing fire. Such a system, however, does not assure protection against property damage or loss of life resulting from a fire.

The Manufacturer recommends that smoke and/or heat detectors be located throughout a protected premise following the recommendations of the National Fire Protection Association Standard 72 (NFPA 72), manufacturer's recommendations, State and local codes, and the recommendations contained in the Guides for Proper Use of System Smoke Detectors, which are made available at no charge to all installing dealers. These documents can be found at <http://www.systemsensor.com/html/applicat.html>. A study by the Federal Emergency Management Agency (an agency of the United States government) indicated that smoke detectors may not go off in as many as 35% of all fires. While fire alarm systems are designed to provide early warning against fire, they do not guarantee warning or protection against fire. A fire alarm system may not provide timely or adequate warning, or simply may not function, for a variety of reasons:

Smoke detectors may not sense fire where smoke cannot reach the detectors such as in chimneys, in or behind walls, on roofs, or on the other side of closed doors. Smoke detectors also may not sense a fire on another level or floor of a building. A second-floor detector, for example, may not sense a first-floor or basement fire.

Particles of combustion or "smoke" from a developing fire may not reach the sensing chambers of smoke detectors because:

- Barriers such as closed or partially closed doors, walls, or chimneys may inhibit particle or smoke flow.
- Smoke particles may become "cold," stratify, and not reach the ceiling or upper walls where detectors are located.
- Smoke particles may be blown away from detectors by air outlets.
- Smoke particles may be drawn into air returns before reaching the detector.

The amount of "smoke" present may be insufficient to alarm smoke detectors. Smoke detectors are designed to alarm at various levels of smoke density. If such density levels are not created by a developing fire at the location of detectors, the detectors will not go into alarm.

Smoke detectors, even when working properly, have sensing limitations. Detectors that have photoelectronic sensing chambers tend to detect smoldering fires better than flaming fires, which have little visible smoke. Detectors that have ionizing-type sensing chambers tend to detect fast-flaming fires better than smoldering fires. Because fires develop in different ways and are often unpredictable in their growth, neither type of detector is necessarily best and a given type of detector may not provide adequate warning of a fire.

Smoke detectors cannot be expected to provide adequate warning of fires caused by arson, children playing with matches (especially in bedrooms), smoking in bed, and violent explosions (caused by escaping gas, improper storage of flammable materials, etc.).

Heat detectors do not sense particles of combustion and alarm only when heat on their sensors increases at a predetermined rate or reaches a predetermined level. Rate-of-rise heat detectors may be subject to reduced sensitivity over time. For this reason, the rate-of-rise feature of each detector should be tested at least once per year by a qualified fire protection specialist. Heat detectors are designed to protect property, not life.

IMPORTANT! Smoke detectors must be installed in the same room as the control panel and in rooms used by the system for the connection of alarm transmission wiring, communications, signaling, and/or power. If detectors are not so located, a developing fire may damage the alarm system, crippling its ability to report a fire.

Audible warning devices such as bells may not alert people if these devices are located on the other side of closed or partly open doors or are located on another floor of a building. Any warning device may fail to alert people with a disability or those who have recently consumed drugs, alcohol or medication. Please note that:

- Strobes can, under certain circumstances, cause seizures in people with conditions such as epilepsy.
- Studies have shown that certain people, even when they hear a fire alarm signal, do not respond or comprehend the meaning of the signal. It is the property owner's responsibility to conduct fire drills and other training exercise to make people aware of fire alarm signals and instruct them on the proper reaction to alarm signals.
- In rare instances, the sounding of a warning device can cause temporary or permanent hearing loss.

A fire alarm system will not operate without any electrical power. If AC power fails, the system will operate from standby batteries only for a specified time and only if the batteries have been properly maintained and replaced regularly.

Equipment used in the system may not be technically compatible with the control panel. It is essential to use only equipment listed for service with your control panel.

Telephone lines needed to transmit alarm signals from a premise to a central monitoring station may be out of service or temporarily disabled. For added protection against telephone line failure, backup radio transmission systems are recommended.

The most common cause of fire alarm malfunction is inadequate maintenance. To keep the entire fire alarm system in excellent working order, ongoing maintenance is required per the manufacturer's recommendations, and UL and NFPA standards. At a minimum, the requirements of NFPA 72 shall be followed. Environments with large amounts of dust, dirt or high air velocity require more frequent maintenance. A maintenance agreement should be arranged through the local manufacturer's representative. Maintenance should be scheduled monthly or as required by National and/or local fire codes and should be performed by authorized professional fire alarm installers only. Adequate written records of all inspections should be kept.

Limit-C1-2-2007

Installation Precautions

Adherence to the following will aid in problem-free installation with long-term reliability:

WARNING - Several different sources of power can be connected to the fire alarm control panel. Disconnect all sources of power before servicing. Control unit and associated equipment may be damaged by removing and/or inserting cards, modules, or interconnecting cables while the unit is energized. Do not attempt to install, service, or operate this unit until manuals are read and understood.

CAUTION - System Re-acceptance Test after Software Changes: To ensure proper system operation, this product must be tested in accordance with NFPA 72 after any programming operation or change in site-specific software. Re-acceptance testing is required after any change, addition or deletion of system components, or after any modification, repair or adjustment to system hardware or wiring. All components, circuits, system operations, or software functions known to be affected by a change must be 100% tested. In addition, to ensure that other operations are not inadvertently affected, at least 10% of initiating devices that are not directly affected by the change, up to a maximum of 50 devices, must also be tested and proper system operation verified.

This system meets NFPA requirements for operation at 0-49° C/32-120° F and at a relative humidity 93% ± 2% RH (non-condensing) at 32°C ± 2°C (90°F ± 3°F). However, the useful life of the system's standby batteries and the electronic components may be adversely affected by extreme temperature ranges and humidity. Therefore, it is recommended that this system and its peripherals be installed in an environment with a normal room temperature of 15-27° C/60-80° F.

Verify that wire sizes are adequate for all initiating and indicating device loops. Most devices cannot tolerate more than a 10% I.R. drop from the specified device voltage.

Like all solid state electronic devices, this system may operate erratically or can be damaged when subjected to lightning induced transients. Although no system is completely immune from lightning transients and interference, proper grounding will reduce susceptibility. Overhead or outside aerial wiring is not recommended, due to an increased susceptibility to nearby lightning strikes. Consult with the Technical Services Department if any problems are anticipated or encountered.

Disconnect AC power and batteries prior to removing or inserting circuit boards. Failure to do so can damage circuits.

Remove all electronic assemblies prior to any drilling, filing, reaming, or punching of the enclosure. When possible, make all cable entries from the sides or rear. Before making modifications, verify that they will not interfere with battery, transformer, or printed circuit board location.

Do not tighten screw terminals more than 9 in-lbs. Overtightening may damage threads, resulting in reduced terminal contact pressure and difficulty with screw terminal removal.

This system contains static-sensitive components. Always ground yourself with a proper wrist strap before handling any circuits so that static charges are removed from the body. Use static suppressive packaging to protect electronic assemblies removed from the unit.

Follow the instructions in the installation, operating, and programming manuals. These instructions must be followed to avoid damage to the control panel and associated equipment. FACP operation and reliability depend upon proper installation.

Precau-D1-9-2005

FCC Warning

WARNING: This equipment generates, uses, and can radiate radio frequency energy and if not installed and used in accordance with the instruction manual may cause interference to radio communications. It has been tested and found to comply with the limits for class A computing devices pursuant to Subpart B of Part 15 of FCC Rules, which is designed to provide reasonable protection against such interference when devices are operated in a commercial environment. Operation of this equipment in a residential area is likely to cause interference, in which case the user will be required to correct the interference at his or her own expense.

Canadian Requirements

This digital apparatus does not exceed the Class A limits for radiation noise emissions from digital apparatus set out in the Radio Interference Regulations of the Canadian Department of Communications.

Le present appareil numerique n'emette pas de bruits radioelectriques depassant les limites applicables aux appareils numeriques de la classe A prescrites dans le Reglement sur le brouillage radioelectrique edicte par le ministere des Communications du Canada.

LiteSpeed™ is a trademark; and FireLite® Alarms is a registered trademark of Honeywell International Inc. Microsoft® and Windows® are registered trademarks of the Microsoft Corporation.

©2010 by Honeywell International Inc. All rights reserved. Unauthorized use of this document is strictly prohibited.

Software Downloads

In order to supply the latest features and functionality in fire alarm and life safety technology to our customers, we make frequent upgrades to the embedded software in our products. To ensure that you are installing and programming the latest features, we strongly recommend that you download the most current version of software for each product prior to commissioning any system. Contact Technical Support with any questions about software and the appropriate version for a specific application.

Documentation Feedback

Your feedback helps us keep our documentation up-to-date and accurate. If you have any comments or suggestions about our online Help or printed manuals, you can email us.

Please include the following information:

- Product name and version number (if applicable)
- Printed manual or online Help
- Topic Title (for online Help)
- Page number (for printed manual)
- Brief description of content you think should be improved or corrected
- Your suggestion for how to correct/improve documentation

Send email messages to:

FireSystems.TechPubs@honeywell.com

Please note this email address is for documentation feedback only. If you have any technical issues, please contact Technical Services.

Table of Contents

Section 1: Product Description	11
1.1: Product Features	12
1.2: Specifications.....	17
1.3: Indicators	20
1.3.1: LEDs Located on Main Circuit Board:.....	20
1.3.2: ACC-ZPM Zone Page Module (ACC-25/50DAZS Only)	20
1.3.3: ACC-AAM25 Audio Amplifier Module	20
1.4: Circuits.....	20
1.5: Components	21
1.6: Optional Modules	23
1.7: Getting Started	23
1.7.1: ACC-25/50 With ACC-25/50DA(s), System Requiring More Than 50 Watts of Audio Power	24
1.7.2: ACC-25/50ZS/T With ACC-25/50DAZS, System Requiring More Than 50 Watts of Audio Power..	24
Section 2: Field Programming	25
2.1: S1 DIP Switch Settings on Distributed Audio Motherboard	26
2.2: S2 DIP Switch Settings on Distributed Audio Motherboard	28
2.3: S3 - Battery Charger Switch on Distributed Audio Motherboard	28
2.4: ACC-ZPM Zone Page Module	28
2.4.1: S1 DIP Switch Settings on ACC-ZPM.....	28
2.4.2: S2 and S3 Addressing Rotary Switches	29
ACC-ZPM Addressing for Style Y (Class B) Audio Circuits.....	29
ACC-ZPM Addressing for Style Z (Class A) Audio Circuits.....	29
2.5: ACC-ZSM Zone Splitter Module	30
2.6: Switch SW1 on ACC-AAM25 Audio Amplifier Module	30
2.7: Switch SW1 Settings on Optional FC-MGM Module.....	31
Section 3: Installation.....	33
3.1: Mounting.....	33
3.2: Backbox Installation	33
3.2.1: Transformer Installation	36
3.3: Operating Power	37
3.4: Auxiliary DC Power Output Connections	39
3.5: Input Circuits	39
3.5.1: Master Command Bus	39
3.5.2: CMD Input Circuits.....	40
3.5.3: Trouble Contact Input.....	40
3.6: Output Circuits.....	41
3.6.1: Trouble Relay - TB1	41
3.6.2: AC Power Loss Relay - TB11	41
3.6.3: Notification Appliance Circuit (Speakers)	42
3.6.4: ACC-ZPM Zone Page Module - Zone System Serial Link.....	42
3.6.5: ACC-ZSM Zone Splitter Module.....	44
3.7: UL Power-limited Wiring Requirements.....	45
3.8: Installation of Option Modules.....	46
3.8.1: Audio Amplifier Module (ACC-AAM25)	46
3.8.2: 70.7 V _{RMS} Transformer Module (FC-XRM70).....	47
3.8.3: FC-MGM Message Generator Module.....	48
3.8.4: FC-LPS Local Playback Speaker Module.....	49
Section 4: Operating Instructions	52
4.1: Message Recording.....	52
4.1.1: Record Push Button (on optional FC-MGM Module)	52
4.2: Playback Button.....	53

4.2.1: LEDs on Main Circuit Board.....	54
4.2.2: LEDs on Optional Message Generator Module (FC-MGM).....	54
4.2.3: LEDs on Audio Amplifier Module.....	55
4.2.4: LEDs on ACC-ZPM (ACC-25/50DAZS Only)	55
4.3: Operation.....	55
4.3.1: Fire Alarm.....	55
4.3.2: Fire Alarm Restoral	55
4.3.3: General Page Using Optional Remote Microphone (ACC-25/50DA Only)	55
4.3.4: Emergency Page Using Optional Remote Microphone (ACC-25/50DA Only).....	55
4.3.5: Trouble Condition Response	56
4.3.6: Trouble Condition Restoral	57
Section 5: Application Examples	59
5.1: ACC-25/50 & ACC-25/50DA Step-by-Step Install/Setup	59
5.2: ACC-25/50ZS/T & ACC-25/50DAZS Step-by-Step Install/Setup	59
5.3: One Speaker Circuit.....	60
5.3.1: Single Channel.....	60
5.3.2: Dual Channel	61
5.4: One Speaker Circuit With Backup.....	62
5.4.1: Single Channel.....	62
5.4.2: Dual Channel	63
5.5: Two Speaker Circuits	64
5.5.1: Single Channel.....	64
5.5.2: Dual Channel	65
5.6: ACC-25/50DA High-Power, Multi-floor Application.....	66
5.7: ACC-25/50 Series and ACC-25/50DA Installation.....	67
5.8: 16 Theater Cineplex Utilizing ACC-25/50ZS/T.....	69
5.9: Audio Command Center 24 Zone System	70
Section 6: Power Supply Calculations	72
6.1: Overview.....	72
6.2: Calculating the AC Branch Circuit.....	72
6.3: Calculating the System Current Draw	72
6.3.1: Overview.....	72
6.3.2: How to use Table 6.2 to calculate system current draws.....	73
6.4: Calculating the Battery Size.....	74
6.4.1: NFPA Battery Requirements	74
6.4.2: Selecting and Locating Batteries	74
Appendix A: Digital Voice Messages.....	76
Appendix B: Addressable Module Connections.....	77
Appendix C: Wiring Requirements	78
Index	79

This audio panel has been designed to comply with standards set forth by the following regulatory agencies:

- Underwriters Laboratories Standard UL 864
- NFPA 72 National Fire Alarm Code

Before proceeding, the installer should be familiar with the following documents.



NFPA Standards

This Audio Distribution Panel complies with the following NFPA Standards:

NFPA 72 National Fire Alarm Code

Note: Audible signal appliances used in public mode applications, are required to have minimum sound levels of 75 dBA at 10 feet (3 meters) and a maximum level of 120 dBA at the minimum hearing distance from the audible appliance.

To ensure that the appliance is clearly heard, the audible appliance sound level must be at least 15 dBA above the average ambient sound level or 5 dBA above the maximum sound level with a duration of at least 60 seconds, depending on which level is greater, with the sound level being measured 5 feet (1.5 meters) above the floor.



Underwriters Laboratories Documents:

- UL 38 Manually Actuated Signaling Boxes
- UL 217 Smoke Detectors, Single and Multiple Station
- UL 228 Door Closers–Holders for Fire Protective Signaling Systems
- UL 268 Smoke Detectors for Fire Protective Signaling Systems
- UL 268A Smoke Detectors for Duct Applications
- UL 346 Waterflow Indicators for Fire Protective Signaling Systems
- UL 464 Audible Signaling Appliances
- UL 521 Heat Detectors for Fire Protective Signaling Systems
- UL 864 Standard for Control Units for Fire Protective Signaling Systems
- UL 1481 Power Supplies for Fire Protective Signaling Systems
- UL 1638 Visual Signaling Appliances
- UL 1711 Amplifiers for Fire Protective Signaling Systems
- UL 1971 Signaling Devices for Hearing Impaired

Other:

- NEC Article 250 Grounding
- NEC Article 300 Wiring Methods
- NEC Article 760 Fire Protective Signaling Systems
- Applicable Local and State Building Codes
- Requirements of the Local Authority Having Jurisdiction (LAHJ)

Fire•Lite Documents

- | | |
|---|-----------------|
| Fire•Lite Device Compatibility Document | Document #15384 |
| FCPS-24F(E) Field Charger/Power Supply | Document #50079 |
| FCPS-2404 Field Charger/Power Supply | Document #51486 |
| FCPS-24FS Field Charger/Power Supply | Document #51883 |
| MS-9200(C)/E Technical Manual | Document #51003 |
| MS-9200UD Technical Manual | Document #51906 |

MS-9600 Technical Manual	Document #51335
MS-5210UD Technical Manual	Document #50193
ACC-25/50 Series Manual	Document #51889
SLC Wiring Manual (with addressable devices)	Document #51309

This product has been certified to comply with the requirements in the Standard for Control Units and Accessories for Fire Alarm Systems, UL 864, 9th Edition. Operation of this product with products not tested for UL 864, 9th Edition has not been evaluated. Such operation requires the approval of the local Authority Having Jurisdiction (AHJ).

Audio Command Center Distributed System

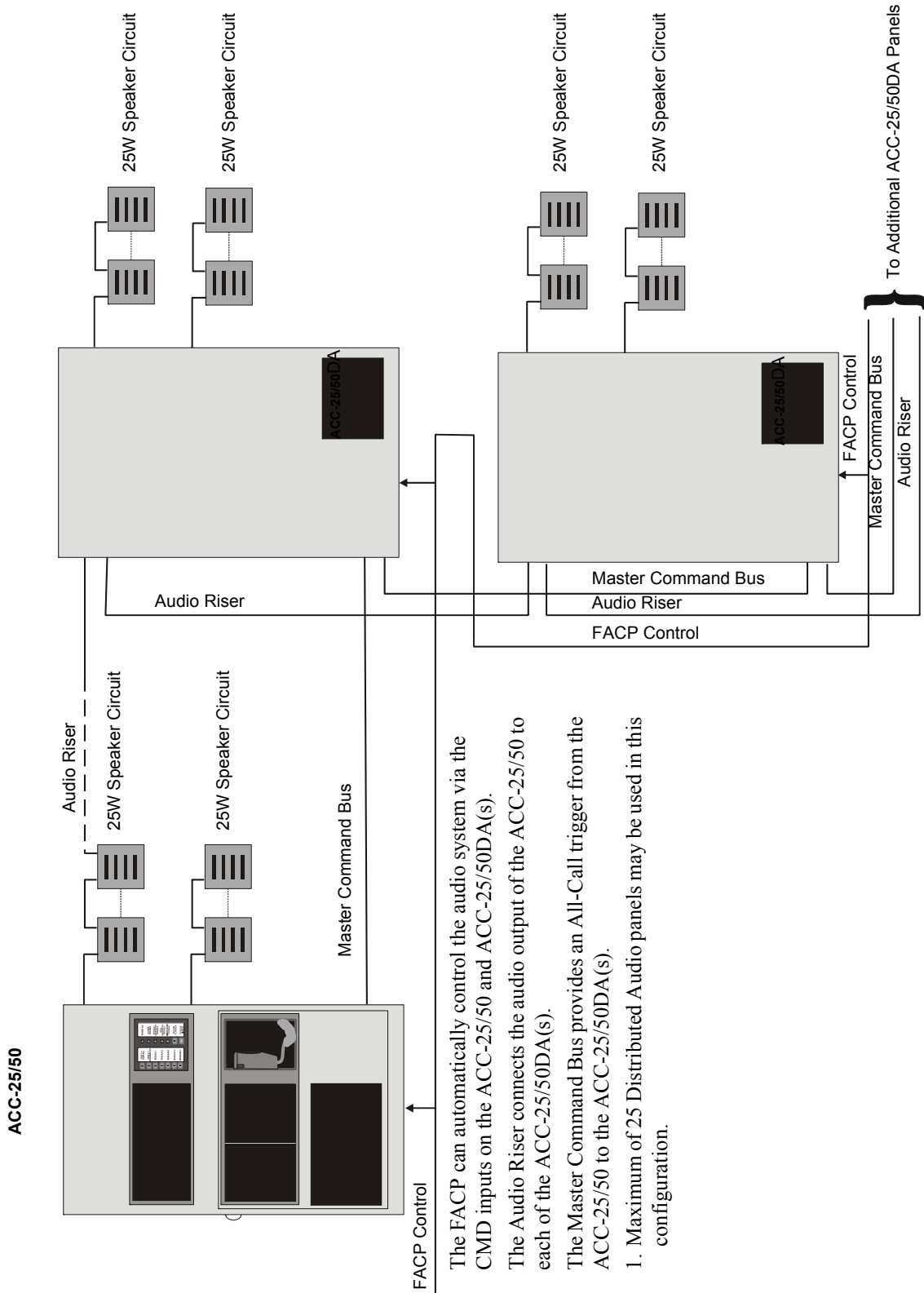

1. The FACP can automatically control the audio system via the CMD inputs on the ACC-25/50 and ACC-25/50DA(s).
2. The Audio Riser connects the audio output of the ACC-25/50 to each of the ACC-25/50DA(s).
3. The Master Command Bus provides an All-Call trigger from the ACC-25/50 to the ACC-25/50DA(s).
 1. Maximum of 25 Distributed Audio panels may be used in this configuration.

Audio Command Center Zone System Up to 24 Zones @ 150W (max.)

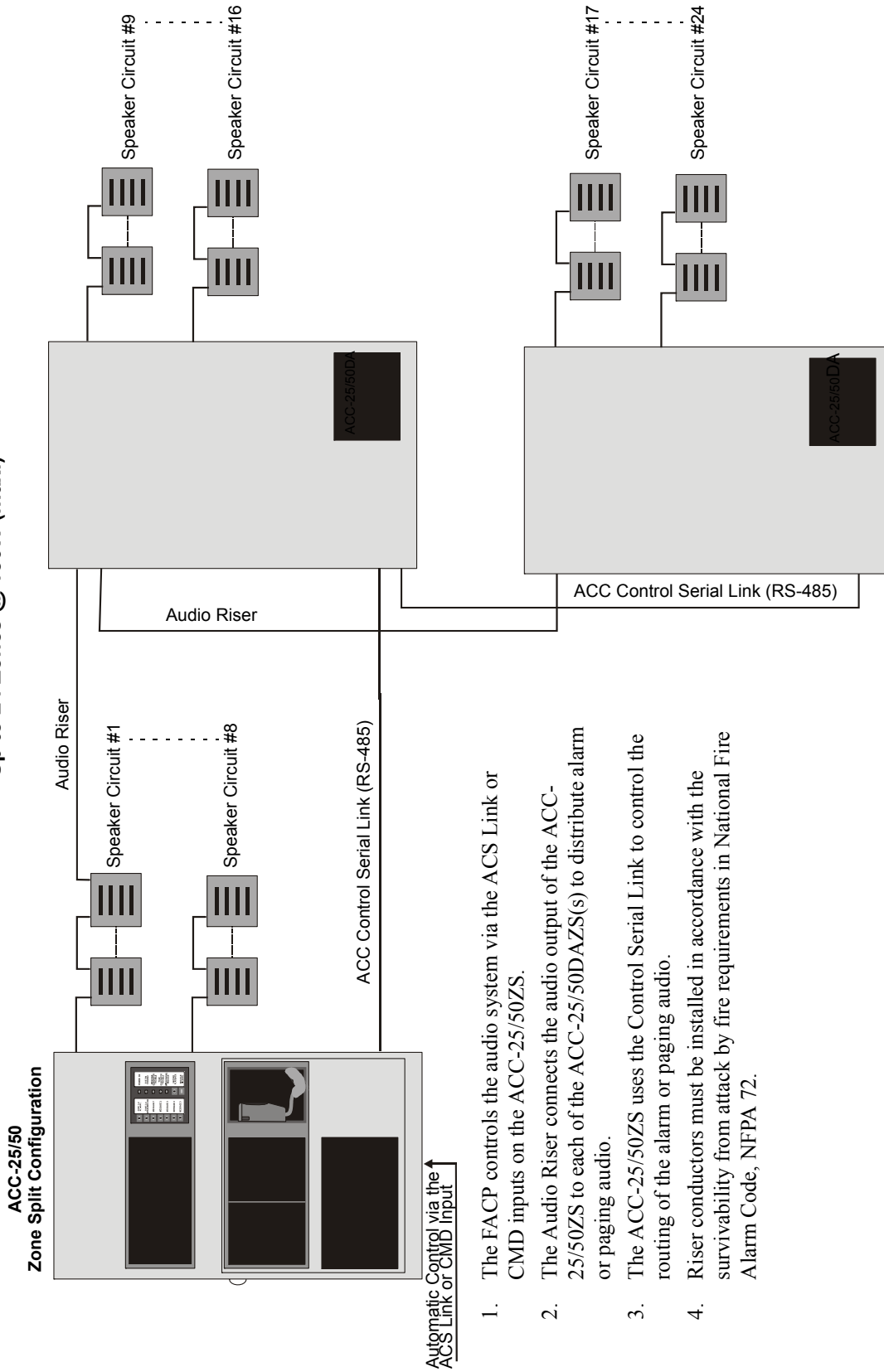

1. The FACP controls the audio system via the ACS Link or CMD inputs on the ACC-25/50ZS.
2. The Audio Riser connects the audio output of the ACC-25/50ZS to each of the ACC-25/50DAZS(s) to distribute alarm or paging audio.
3. The ACC-25/50ZS uses the Control Serial Link to control the routing of the alarm or paging audio.
4. Riser conductors must be installed in accordance with the survivability from attack by fire requirements in National Fire Alarm Code, NFPA 72.

accdzsdistsys.wmf

Section 1: Product Description

The AUDIO•COMMAND•CENTER•25/50DA Distributed Panel (ACC-25/50DA) and AUDIO•COMMAND•CENTER•25/50DAZS Zone System Distributed Audio Panel (ACC-25/50DAZS) are single channel, 25 watt, 25 V_{RMS}, emergency voice evacuation panels which are designed to interface directly to the AUDIO•COMMAND•CENTER•25/50 (ACC-25/50) Series audio panels. The ACC-25/50DA Series, which supports up to eight speaker circuits, can be used to distribute voice evacuation audio over a building's speaker system. The audio riser input provides automatic gain control (AGC) which compensates for any audio signal loss due to circuit loading or cable length, ensuring that a full output signal is delivered to the speakers. An optional FC-MGM message generator is available with standard pre-recorded message or programmable message capability (up to sixty seconds). An integral power supply with battery charger supplies operational power. An ACC-AAM25 audio amplifier is provided standard with each base unit. An optional second ACC-AAM25 amplifier is also available for backup purposes or to provide an additional 25 watt speaker circuit. Optional 70 V_{RMS} conversion modules are also available for installations where 70 V_{RMS} speakers are to be installed or already exist. The modular design allows for ease-of-serviceability.

The ACC-25/50DA can be automatically activated by the five CMD inputs from an FACP. The ACC-25/50DAZS can be automatically activated via the Zone System serial communications link from the ACC-25/50ZS/T.

Two Command Input Circuits can be independently field programmed for activation by an FACP Notification Appliance Circuit reverse polarity or by closure of a supervised normally open contact and three Command Input Circuits activate on contact closure. CMD 1 and CMD 2 provide terminals for NAC input and output to allow installation of the audio panel anywhere along the NAC circuit being used to activate it.

The ACC-25/50DAZS includes an ACC-ZPM Zone Page Module and an ACC-ZSM Zone Splitter Module. These modules provide up to eight speaker circuits that may be manually or automatically activated.

Significant technological enhancements set the ACC-25/50DA Series apart from other voice panels. *These enhancements include full supervision in both active (alarm or music) and standby conditions.*



NOTE: Music cannot be used for ACC-25/50DAZS.

Supervision is provided for:

- ✓ amplifier outputs
- ✓ field wiring (shorts and opens)
- ✓ optional message generator (FC-MGM)
- ✓ all tone generators
- ✓ optional remote microphone

If the audio riser input fails, the distributed audio panel can be programmed to switch to the built-in tone generator or optional FC-MGM Message Generator. If the FC-MGM fails or is not installed, the tone generators on the main circuit board can be automatically switched in as backups.

Power is fed independently to each amplifier so that a short circuit in one amplifier will not shut down the other. Full output power of 25 watts per amplifier is generated while in a low battery condition. Power is not diminished when the optional 70 V_{RMS} transformer module is installed. Audio is amplified utilizing modern integrated circuits as opposed to transformer technology. This provides for very low signal distortion for crystal clear audio.

Primary applications for the audio panels include structures such as restaurants, schools, auditoriums, places of worship, buildings with occupancies over 50, etc. The ACC-25/50DA Distributed Audio Series is designed to interface directly to addressable or conventional fire alarm control panels or with the ACC-25/50 series audio control panels to distribute audio in systems that require more than 50 watts.

1.1 Product Features

- 25 watts of 25 V_{RMS} audio power (expandable to 50 watts) per panel
- Automatic gain control (AGC) circuit ensures an unattenuated audio signal on the audio riser input
- Optional 70.7 V_{RMS} conversion module available for each amplifier (note that speaker wiring continues to be supervised in standby, alarm and when background music is playing with this option module installed)
- Modular design for maximum system flexibility
- Unobstructed module access and removable terminal blocks for ease of servicing and module replacement
- Designed to allow easy system expansion
- Five Command Input Circuits:
 - ✓ CMD1 and CMD2 are field selectable to be activated from 12 or 24 VDC Notification Appliance Circuits (reverse polarity) or contact closures
 - ✓ CMD3, CMD4 and CMD5 are activated by contact closures
- Speaker Circuits
 - ✓ single Style Y or Z speaker circuit (one ACC-AAM25 Audio Amplifier provided with base unit)
 - ✓ two Style Y or Style Z speaker circuits (with optional second ACC-AAM25 Audio Amplifier installed)
 - ✓ eight Style Y or four Style Z speaker circuits using ACC-ZSM Zone Splitter Module
- ACC-25/50DAZS can be controlled by the ACC-25/50ZS/T via the Zone System serial link (EIA-485) to the ACC-ZPM.
- Optional FC-MGM Message Generator Module with standard, prerecorded message:

“May I have your attention please. May I have your attention please. The signal you have just heard indicates a report of a fire in this building. Please proceed to the nearest exit and leave the building. Do not reenter the building unless directed to do so by the proper authorities.”
- Field selectable message capability and custom message field recording capability using optional FC-MGM module’s audio input RCA jack or mini Audio jack for connection to a personal computer
- Record/playback control switches on optional FC-MGM
- One 60-second, two 30-second, three 20-second or four 15-second custom messages on optional FC-MGM
- Integral tone generators field selectable for steady, slow-whoop, high-low or chime tones
- Powered by integral AC power supply or batteries during AC fail
- Two Form-C trouble relays:
 - ✓ System Trouble Relay - TB1
 - ✓ AC Power Loss Relay - TB11
- 35 mA Special Application auxiliary power output for addressable modules (when interfaced with the Fire•Lite MS-9200(E), MS-9200UD or MS-9600 FACP or equivalent) and End-of-Line power supervision relays

- Optional FC-RM Remote Microphone (includes cabinet and FC-MIM Microphone Interface Module). Refer to the *FC-RM Product Installation Document #51247* for additional information
- Optional local playback speaker (FC-LPS) for use with optional FC-MGM
- System Status LEDs (refer to Section “Indicators” on page 20)

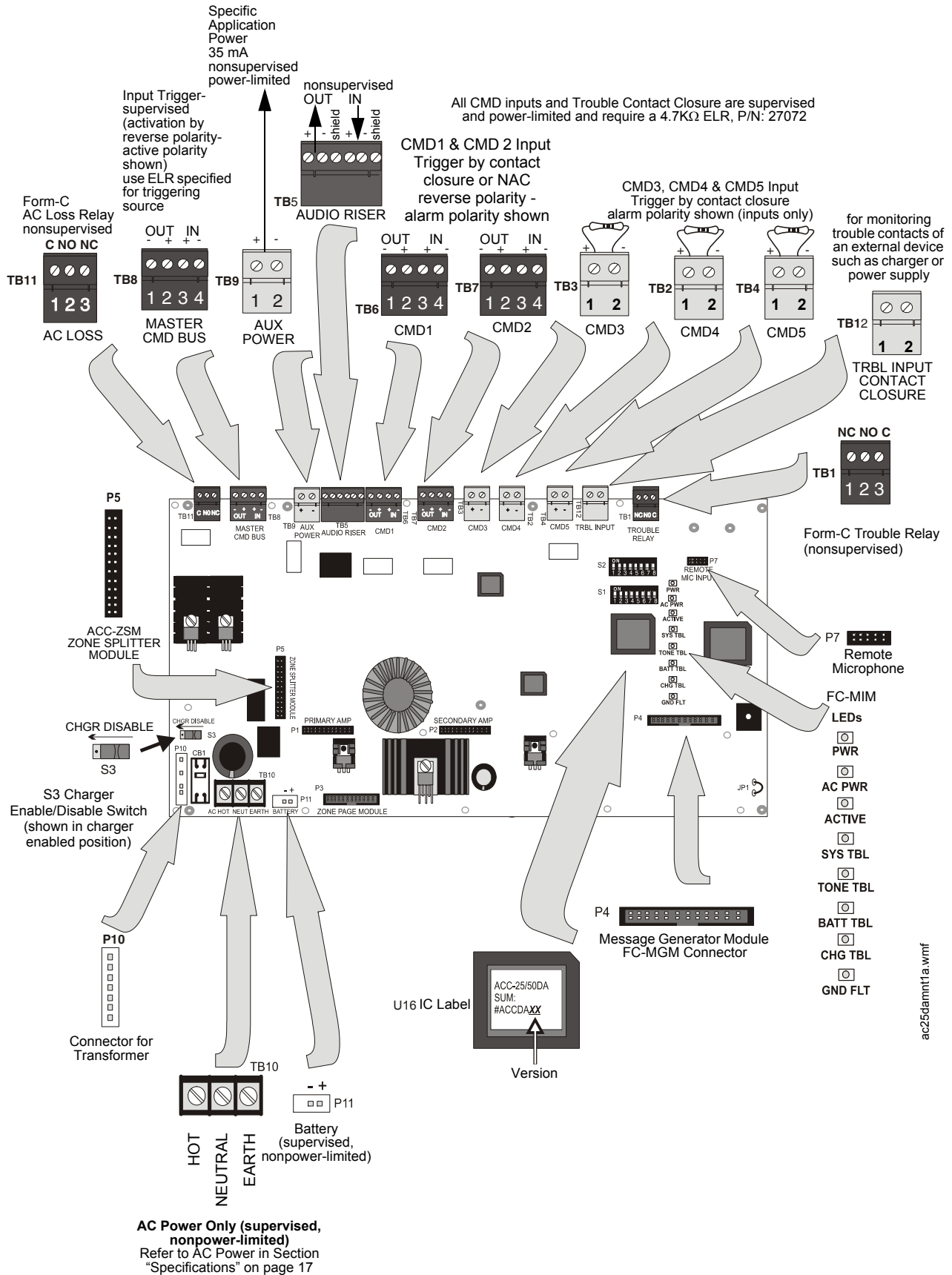

Figure 1.1 Distributed Audio Main Board



CAUTION: OBSERVE POLARITY
 MATCH PROPER POLARITY CONNECTIONS TO FIELD WIRING AND SPEAKERS. POLARITY SHOWN IS IN THE STANDBY AND ALARM CONDITIONS.

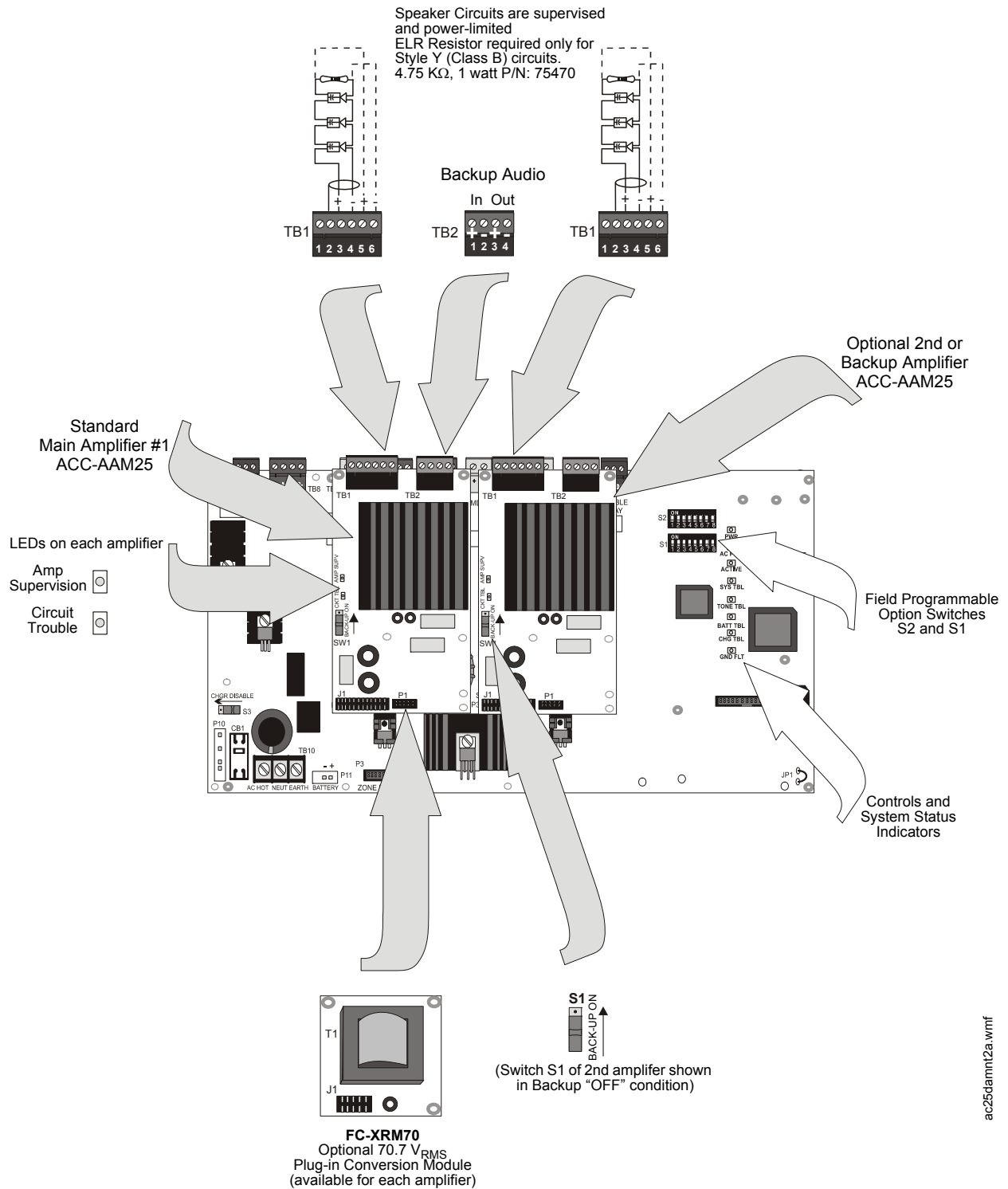

Figure 1.2 Distributed Audio Board With Amplifiers

ACC-ZSM and ACC-ZPM Modules for Distributed Audio with Zone Splitter Feature Only

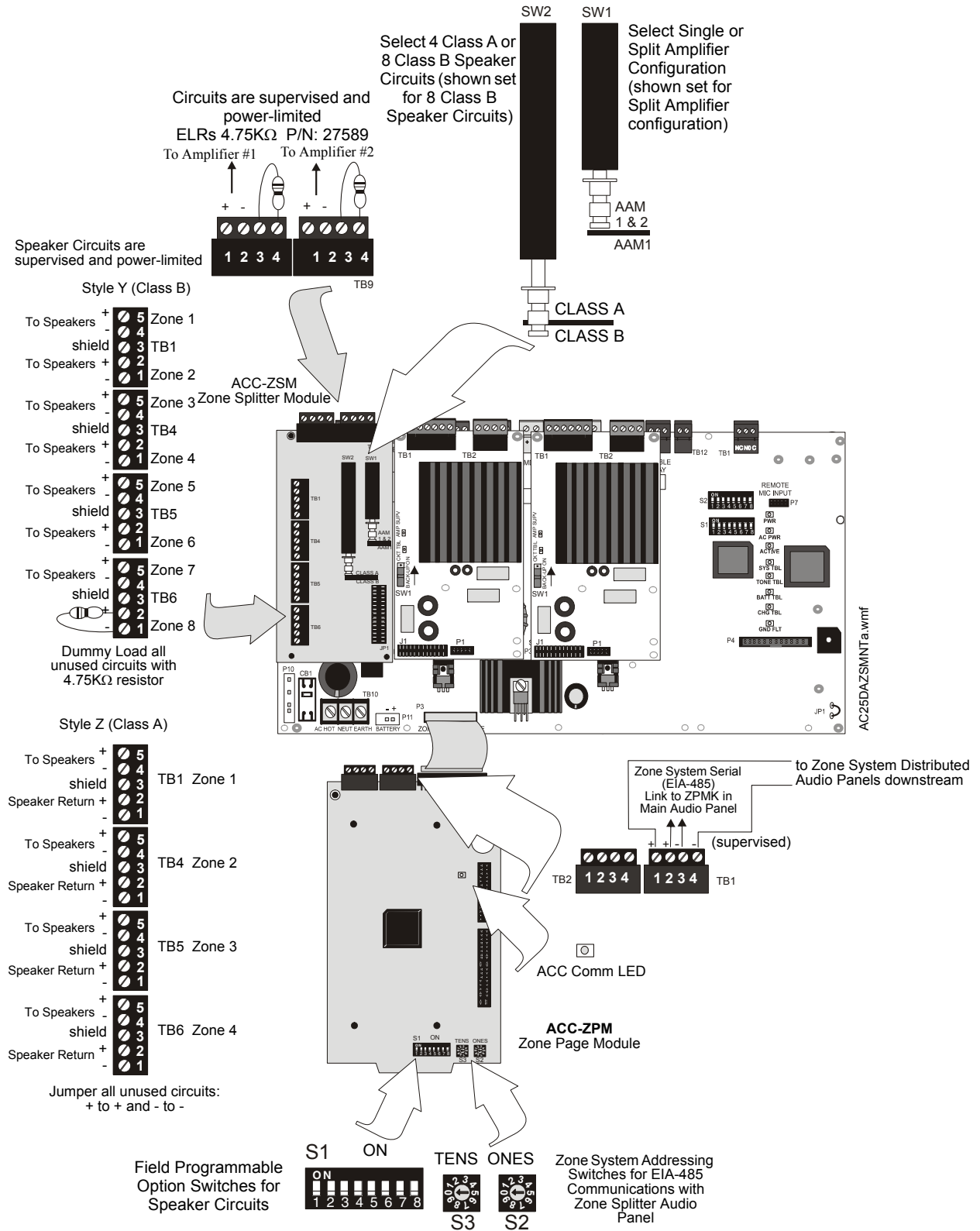

Figure 1.3 Distributed Audio Board With ACC-ZPM & ACC-ZSM Modules

1.2 Specifications

AC Power - TB10

ACC-25/50DA & ACC-25/50DAZS:120 VAC, 60 Hz, 1.57 amp.

Supervised, nonpower-limited circuit

Wire size: minimum #14 AWG with 600 V insulation.

AC Loss Relay - TB11

Operation: normally energized fail-safe relay transfers on AC power loss for independent monitoring by DACT.

AC Loss relay contact rating: 2.0 amps @ 30 VDC (resistive), 0.6 amps @ 30 VAC (resistive)

Nonsupervised circuit

Battery (sealed lead acid only) - P11

Maximum Charging Circuit: Normal Flat Charge - 27.6V @ 0.800 amp

Maximum Charger Capacity: 18 Amp Hour battery (cabinet holds maximum 18 AH Battery.)

Supervised, nonpower-limited circuit

Command Input Circuits (alarm polarities shown)

- CMD1 - TB6 Terminals 3(+) & 4(-) are input terminals and Terminals 1(-) and 2(+) are output terminals which provide feed through of the NAC circuits to NAC devices down stream
- CMD2 - TB7 Terminals 3(+) & 4(-) are input terminals and Terminals 1(-) and 2(+) are output terminals which provide feed through of the NAC circuits to NAC devices down stream
- CMD3 - TB2 Terminals 1(+) & 2(-) are input terminals for contact closure only
- CMD4 - TB3 Terminals 1(+) & 2(-) are input terminals for contact closure only
- CMD5 - TB4 Terminals 1(+) & 2(-) are input terminals for contact closure only

Operation: CMD1 & CMD2 circuits are independently field programmable to activate amplifiers on NAC polarity reversal or contact-closure. **IMPORTANT!** *When CMD1 and CMD2 are configured for reverse polarity, the NAC cannot be Coded.*

CMD3, CMD4 and CMD5 are fixed to activate on contact closure only

Power-limited and supervised circuitry

Normal Operating Voltage: 10.5 VDC - 29 VDC

Maximum Voltage: 29 VDC

NAC Reverse Polarity Current (requires End-of-Line Resistor from NAC): 1.6 mA maximum.

Contact Closure Operation Current (requires 4.7K, ½ watt End-of-Line Resistor P/N 27072): 6.6 mA maximum

Maximum Wiring Impedance CMD1 - CMD5 (Contact Closure Operation): 200Ω

Maximum Input Impedance:

- CMD1 & CMD2 (Reverse Polarity Operation): 20KΩ
- CMD1 - CMD5 (Contact Closure Operation): 3.4KΩ

Audio Amplifier Module - Standard ACC-AAM25 Amplifier plugs into P1 of main circuit board, optional ACC-AAM25 Amplifier plugs into P2 of main circuit board

Backup Audio In - TB2, Terminals 1(+) & 2(-) [Out Terminals 3(+) & 4(-)] on Amplifier Module

Operation: When TB2 is wired between the two amplifiers of a panel, the optional amplifier provides backup to the standard amplifier. Switch S1 on the backup amplifier must be 'ON' and jumpers placed from backup amplifier TB2 Terminal 3 to standard amplifier TB2 Terminal 1 and from backup amplifier TB2 Terminal 4 to standard amplifier TB2 Terminal 2. Refer to Section "One Speaker Circuit With Backup" on page 62, for additional information.

Speaker Circuit - TB1 Terminals 3(+) & 4(-) Style Y, 3(+), 4(-), 5(+) & 6(-) Style Z, 1 & 2 Shield (Standby and Alarm Polarity Shown) on Amplifier Module

Power-limited, supervised circuitry

Operation: Circuit can be wired Style Y or Style Z

Normal Operating Voltage: 25 V_{RMS} @ 1 amp max. and maximum Load Impedance of 25Ω

(70.7 V_{RMS} @ 350 mA max. with maximum Load Impedance of 200Ω operation possible by plugging optional FC-XRM70 conversion module into P1 of audio amplifier).

Circuit wiring is supervised during standby, alarm and when background music is playing

Output Power: 25 watts (20 watts when background music is employed).

Frequency Range: 800Hz - 2,800Hz

Maximum total capacitance for each ACC-AAM25: 250 μF.

End-of-Line Resistor required for Style Y circuit: 4.75 KΩ, 1 watt (P/N: 75470)

ACC-ZSM Zone Splitter Module and ACC-ZPM Zone Page Module

Power-limited circuitry

Operation: Circuits on ACC-ZSM can be wired as eight Style Y or four Style Z

Normal Operating Voltage for Speaker Circuits: 25 V_{RMS} @1 amp Max. and maximum Load Impedance of 25Ω

(70.0 V_{RMS} @ 350 mA max. with maximum Load Impedance of 200Ω operation possible by plugging optional FC-XRM70 conversion module into P1 of audio amplifier).

Speaker circuit wiring is supervised during standby and alarm. (*Note that background music is not permitted in Zone Splitter configuration since open-circuit fault detection is not possible.*)

Output Power: 25 watts total.

Frequency Range: 800Hz - 2,800Hz

Maximum total capacitance for ACC-AAM25: 250 μF. (*Note that the total capacitance for the ACC-ZSM speaker outputs must not exceed the maximum of 250 μF.*)

End-of-Line Resistor required for Style Y (Class B) speaker circuit: 4.75 KΩ, 1 watt (P/N: 75470)

TB1 on ACC-ZPM: ACS (EIA-485) electrically isolated link to FACP provides programmed speaker control

Master CMD Bus - TB8 Terminals 1(-), 2(+), 3(+) & 4(-) (active polarity shown)

Provides reverse polarity trigger input from ACC-25/50 Series Master Command Bus Output.

Supervised and power-limited circuitry

Normal Operating Voltage: 24 VDC regulated, filtered.

Maximum Voltage: 25.4 VDC

Reverse Polarity Current: 125 mA maximum.

Standby Voltage: -5 VDC. Short Circuit Current: 0.5 mA.

Maximum Load Resistance: 200 ohms.

Wiring connections to Master CMD Bus Circuit:

- ✓ End-of-Line Resistor required for Class B using Terminals 2(+) & 1(-): 4.7 K Ω , ½ watt (P/N: 27072)
- ✓ Class A (no End-of-Line Resistor) requires the wiring of Terminal 2(+) and Terminal 1(-) to next Distributed Audio Panel

Special Application Power (Aux. Power) - TB9 Terminals 1(+) & 2(-)

Up to 35 mA @ 24 VDC special application power is available for powering addressable modules and associated End-of-Line power supervision relays. Output is unsupervised.

Power-limited circuitry. Refer to the *Device Compatibility Document* for a list of compatible devices.

Form-C Trouble Relay - TB1

Normally energized fail-safe relay transfers its contacts on any panel trouble condition.

TB1 Form-C relay contact rating: 2.0 amps @ 30 VDC (resistive), 0.6 amps @ 30 VAC (resistive).

External Audio Inputs - Optional FC-MGM Message Generator Module on P4

- RCA Audio Jack Input (female connector)
 - Input Impedance: 30K Ω maximum
 - Input Voltage: 700 mV_{RMS} maximum
 - Input Current: 1 mA maximum @ 700 mV
 - Requires preamplifier output. Mates to an RCA phono 'plug' - 3mm diameter, 10mm length, 9mm shell diameter.
- 3.5 mm PC Audio Jack Input (female connector)
 - Input Impedance: 150K Ω maximum
 - Input Voltage: 700 mV_{RMS} maximum
 - Input Current: 1 mA maximum @ 700 mV
 - Requires preamplifier output
 - Interfaces to personal computer line output or headset output
(Some laptop personal computers only provide an audio output for headphones. It may be necessary to adjust the headphone output level for proper recording of voice messages.)
- Microphone Connector for optional standard microphone P/N: FC-MICROPHONE

FC-MIM Microphone Interface Module (Optional) - P7 Connector

Connector P7 provides a connection for the optional FC-MIM Microphone Interface Module which is used to connect the FC-RM Remote Microphone Module to provide remote microphone paging capabilities.

Audio Riser - TB5

Magnetically isolated input utilizes signals up to 70.7 V_{RMS} with a frequency range of 800 Hz to 2,800 Hz.

For ACC-25/50DA Only - If background music is enabled, the maximum input signal to the riser:

- with a 20 watt speaker load per amplifier cannot exceed 25 V_{RMS}
- with a 25 watt speaker load per amplifier cannot exceed 20 V_{RMS}

Trouble Contact Input - TB12

Non-supervised, non-isolated trouble input that can be used by chargers, power supplies, etc.

Contact Closure Operation Current: 1.2 mA maximum

Standby Current: n/a

1.3 Indicators

1.3.1 LEDs Located on Main Circuit Board:

- Power ON (green)
- AC Power (green)
- Active (green)
- System Trouble (yellow)
- Tone Generator Trouble (yellow)
- Battery Trouble (yellow)
- Charger Trouble (yellow)
- Ground Fault (yellow)

1.3.2 ACC-ZPM Zone Page Module (ACC-25/50DAZS Only)

- ACC Comm (green LED) - indicates Communication is active on the serial link to the ACC-25/50ZS. Off indicates no communication.

1.3.3 ACC-AAM25 Audio Amplifier Module

- Circuit Trouble (yellow) - Amplifier module
- Amplifier Supervision (green) - Amplifier module

1.4 Circuits

Input Circuits - CMD1, CMD2, CMD3, CMD4 & CMD5

- Input circuits CMD1 and CMD2 are independently field programmable to accept Notification Appliance Circuits or normally open contacts. (**IMPORTANT!** *When CMD1 and CMD2 are configured for reverse polarity, the NAC cannot be Coded*). Terminals are provided to allow feed-through of the NACs, allowing placement of the ACC-25/50 Series anywhere along a Notification Appliance Circuit. A trouble on the ACC-25/50DA will cause relay contacts at the out terminals of CMD1 to open, causing an NAC circuit trouble at the FACP.



NOTE: The ACC-25/50DA will not open the "OUT" terminals while in alarm. Monitoring ACC-25/50DA troubles while in alarm requires use of the independent trouble relay at TB1.

- Programming CMD1 and/or CMD2 for activation on contact closure will allow activation of the amplifiers on a normally open contact transfer to the closed condition. Contact wiring is supervised for open conditions. A short will cause amplifier activation (contact closure).
- Input circuits CMD3, CMD4 and CMD5 will only activate on contact closure which will allow activation of the amplifiers on a normally open contact transfer to the closed condition. Contact wiring is supervised for open conditions.
- Contact Closure Trouble Input is used for identification of troubles on an optional external power supply or charger.

Audio Input Jacks (located on optional FC-MGM Message Generator Module)

- RCA Jack provides convenient connection to an audio source such as a tape player for recording a new digital message.
- PC Jack provides convenient connection to an audio source such as a personal computer for recording a new digital message. The jack allows vertical plug-in of a standard mini-jack cable.
- Microphone Jack provides connection for a standard compatible microphone.

Audio Amplifier Module [ACC-AAM25]

A single Audio Amplifier Module is installed in the Distributed Audio Panel. The amplifier provides 25 watts of power at 25 V_{RMS}. A second optional ACC-AAM25 can be installed as a backup to the primary or to expand speaker power to 50 watts. An optional module, P/N: FC-XRM70, converts the 25 V_{RMS} output to 70.7 V_{RMS}. One fully supervised and power-limited speaker circuit is provided on the amplifier module. The circuit can be wired for Style Y (Class B) or Style Z (Class A) operation.

LEDs are provided to indicate Amplifier Supervision (green indicates amplifier is functional) and Circuit Trouble (yellow indicates field wiring fault or amplifier fault). The LEDs are only visible with the panel door open.

Cabinet

The cabinet is red with an attractive navy blue front overlay. The backbox measures 26.0" x 15.5" x 4.75" and provides space for two batteries (up to 18 Amp Hours).

Figure 1.5 Cabinet

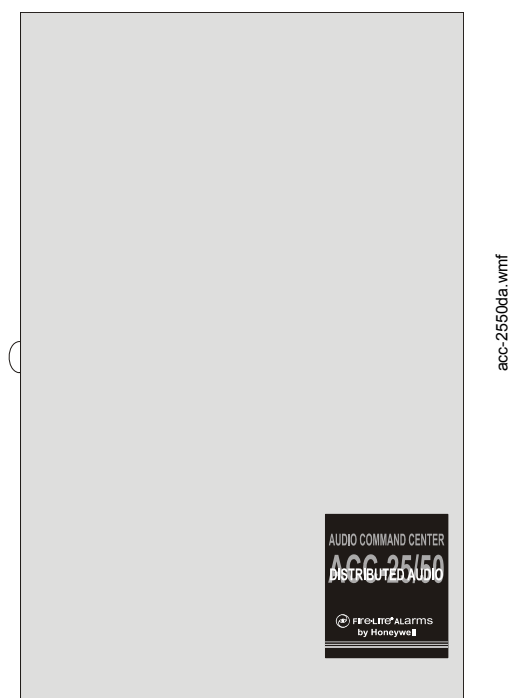

Batteries

The cabinet provides space for 18 Amp Hour batteries (charged by integral Power Supply/Battery Charger module).

1.6 Optional Modules

ACC-AAM25 Audio Amplifier Module

An optional second identical audio amplifier can be plugged into connector P2 located in the lower center of the main circuit board in the Distributed Audio Panel. This amplifier also provides 25 watts of power at 25 V_{RMS} and can therefore be used to expand system power to 50 watts (providing dual 25 watt speaker circuits) or it can be used as a backup amplifier. An option module can also be used to convert the 25 V_{RMS} output to 70.7 V_{RMS} .



NOTE: For ease of access, all wiring should be connected to the terminals on the main circuit board terminal blocks prior to installing the secondary Audio Amplifier Module.

FC-XRM70 Transformer Module 70.7 V_{RMS}

This optional module plugs into connector P1 of the Audio Amplifier Module and provides conversion from 25 V_{RMS} to 70.7 V_{RMS} at full rated 25 watts output power.

FC-MGM Message Generator Module

This optional module provides custom message recording capabilities and system audio backup. The custom message may be recorded from an alternate audio source connected to the audio jack on the FC-MGM. In addition, built-in tone generators, which are located on the main circuit board, provide tones before and after the message as well as backup on message failure. The FACP can automatically control the ACC-25/50DA via CMD2-CMD5 to generate voice messages over its local speaker circuits.



NOTE: The ACC-25/50DAZS uses the FC-MGM for backup purposes if the message from the ACC-25/50ZS/T is lost or interrupted.

FC-LPS Local Playback Speaker

This optional speaker module is mounted on the Distributed Audio Panel main circuit board and connects to the optional FC-MGM module. This unit allows reviewing of the digital messages locally without broadcasting over the system speakers. The optional module must be installed in order to take advantage of the Playback feature. It may be temporarily used to test recorded messages. A mounting kit is included for this purpose. The FC-LPS cannot be permanently mounted in the enclosure and must be removed after use.

FC-RM Remote Microphone Module

The optional microphone module FC-RM, provides general paging capabilities through the remote microphone from the ACC-25/50DA. Announcements can be broadcast over the speaker circuits by pressing the Remote Microphone keyswitch. The FC-MIM Microphone Interface Module must be installed in the ACC-25/50DA for connection to the FC-RM (refer to the *FC-RM Product Installation Document #51247* for installation information).



NOTE: All-Call Paging operations initiated from the ACC-25/50 Series main panel will override the remote microphone.

The ACC-25/50DAZS panel does not support the FC-RM. All remote microphone connections are made on the ACC-25/50ZS/T main panel.

1.7 Getting Started

This section describes the basic guidelines for setting up the ACC-25/50DA Series, assuming that the speaker and FACP cabling has been installed.

1.7.1 ACC-25/50 With ACC-25/50DA(s), System Requiring More Than 50 Watts of Audio Power

- Connect the Audio Riser and Master Command Bus (for All-Call) cabling between the ACC-25/50 and ACC-25/50DA panels. Refer to Section 5, 'Application Examples' on page 59.
- Install backboxes and circuit boards as described in Section 3, 'Installation' on page 33.
- Configure the ACC-25/50 for Single Zone operation using DIP switch S3 switches 1, 2 and 3 on the ACC-MCB motherboard. Refer to Section 2, 'Field Programming' in the ACC-25/50 Series Manual. The ACC-25/50DA DIP switches can be left at the default settings.
- If the optional message generator is installed, record any new voice messages as described in Section 4, 'Operating Instructions' on page 52.

1.7.2 ACC-25/50ZS/T With ACC-25/50DAZS, System Requiring More Than 50 Watts of Audio Power

- Connect the Audio Riser and EIA-485 cabling between the ACC-25/50ZS/T and ACC-25/50DAZS panels. Refer to Section 5, 'Application Examples' on page 59.
- Install backboxes and circuit boards as described in Section 3, 'Installation' on page 33.
- Configure the ACC-ZPMK on the ACC-25/50ZS with the number of ACC-25/50DAZS panels connected on the Zone System serial link.
- Configure the address wheel located on the ACC-ZPM in the ACC-25/50DAZS panel.
- If the optional message generator is installed, record any new voice messages as described in Section 4, "Operating Instructions", on page 52.

Section 2: Field Programming

The ACC-25/50DA can be field programmed using option DIP switches S1 and S2 located in the upper right side of the mother board. It is recommended that tone selection and background music options be reviewed and approved by the local AHJ. Programming DIP switches are also located on the ACC-ZPM Zone Page Module. DIP switches are also located on the optional Message Generator Module (FC-MGM). Refer to the following illustrations for details on DIP switch placement in the ON and OFF positions.



CAUTION: STATIC SENSITIVE COMPONENTS
 IN ORDER TO MINIMIZE RISK OF DAMAGE TO ANY CIRCUITS, DO NOT USE CONDUCTIVE TOOLS WHEN CONFIGURING DIP SWITCHES.

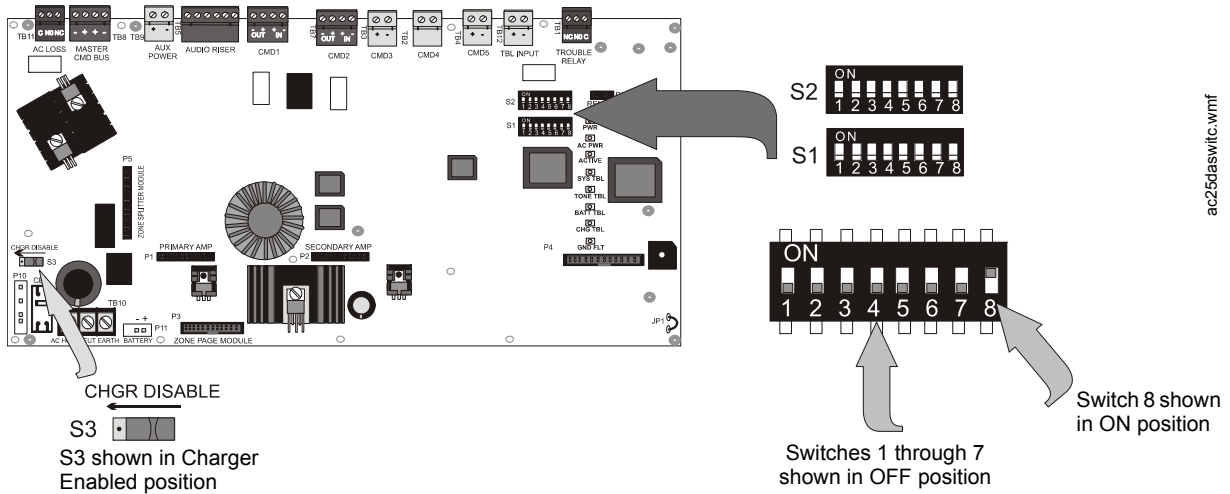

Figure 2.1 Field Programming DIP Switches

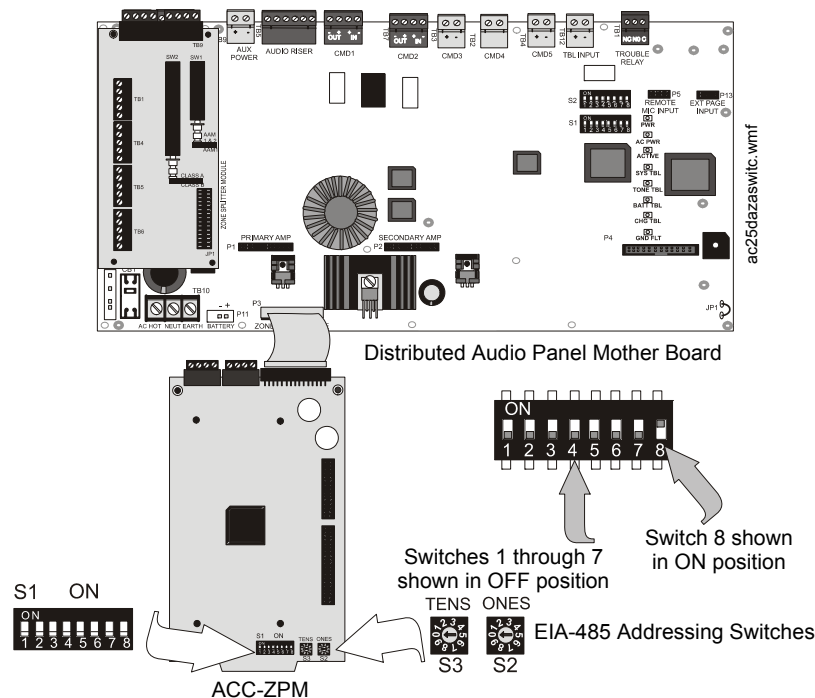

Figure 2.2 Field Programming DIP Switch for ACC-ZPM

2.1 S1 DIP Switch Settings on Distributed Audio Motherboard

The following tables list the ACC-25/50DA Series programmable features and the DIP switch settings required to select a particular feature. A detailed description of each feature is presented in the following pages.

S1 DIP Switch	ON	OFF
1	Enable Temporal Pattern Tone (switches 2 & 3 must be OFF)	Disable Temporal Pattern Tone (factory default) (tone generated as selected by switches 2 & 3)
2	This switch works in conjunction with switch 3 to determine tone to be generated over speakers	
3	Tone transmitted before and after message transmission and as backup tone if message fails: 2 OFF, 3 OFF = Steady Tone 2 OFF, 3 ON = Slow Whoop Tone (factory default) 2 ON, 3 OFF = Hi-Lo Tone 2 ON, 3 ON = Chime	
4	not used	
5	not used	
6	not used	
7 ¹	This switch works in conjunction with switch 8 for message control selection and message length.	
8 ¹	This switch works in conjunction with switch 7 for message control selection and message length. Refer to Table 2.2 for valid settings of switches 7 & 8.	

Table 2.1 S1 DIP Switch Settings on Distributed Audio Panel Motherboard

- 1 Only with FC-MGM option module installed.

The selection of the source of the audio which will be transmitted by the amplifier in a 25 watt system (both amplifiers in a 50 watt system) is determined by three factors:

- ✓ DIP switch settings as detailed in Section “S2 DIP Switch Settings on Distributed Audio Motherboard” on page 28
- ✓ activation of CMD Command Inputs (ACC-25/50DA, or via the Serial Control link from the ACC-25/50ZS/T main panel)
- ✓ installation of the optional FC-MGM Message Generator Module

The following table details which audio sources will be transmitted depending on the conditions stated above and the number of messages that can be recorded along with the duration of each message.

S1 DIP Switch Settings for Switches: 7 8		Message Length FC-MGM	Audio Signal Control ^{1, 2}				
			CMD1 ^{3, 4}	CMD2	CMD3	CMD4	CMD5
0	0	Tone Only ⁵ (no message)	Riser to AAM1 & 2	Tone to AAM1 & 2			
0	0	60 sec.	Riser to AAM1 & 2	message1 to AAM1 & 2			
1	0	30 sec.	Riser to AAM1 & 2	message1 to AAM1 & 2	message2 to AAM1 & 2		
0	1	20 sec.	Riser to AAM1 & 2	message1 to AAM1 & 2	message2 to AAM1 & 2	message3 to AAM1 & 2	
1	1	15 sec.	Riser to AAM1 & 2	message1 to AAM1 & 2	message2 to AAM1 & 2	message3 to AAM1 & 2	message4 to AAM1 & 2

Table 2.2 DIP Switch S1, Switches 7 & 8

- 1 This table is only valid for ACC-25/50DA configurations. The CMD1 through 5 inputs are ignored by the ACC-25/50DAZS, which is controlled, instead, via the Zone System serial link from the ACC-25/50ZS/T. CMD3, CMD4, and CMD5 still require End-of-Line resistors.
- 2 The ACC-25/50DAZS supports local message generation for backup purposes only. All voice messages are input from the ACC-25/50ZS/T panel.
- 3 CMD1 has the highest priority, CMD5 has the lowest priority.
- 4 CMD1 does not open for trouble conditions when configured as an ACC-25/50DAZS
- 5 Tone Only is the **factory default** setting. If the FC-MGM module is not installed, this configuration provides tone only.

2.2 S2 DIP Switch Settings on Distributed Audio Motherboard

S2 DIP Switch	ON	OFF
1	not used	
2	Only AC Loss Relay will transfer upon an AC loss condition.	The CMD1 & Form-C Trouble Relays will track the AC Loss Relay and transfer upon an AC loss condition.
3	Enable Background Music ^{1, 2, 3}	Disable Background Music (factory default)
4	not used	
5	Command Input 1 Activation on Contact Closure	Command Input 1 Activation on NAC polarity reversal (factory default) ⁴
6	Command Input 2 Activation on Contact Closure	Command Input 2 Activation on NAC polarity reversal (factory default) ⁴
7	not used	
8	Local Generation of Evacuation Tone (or voice message if FC-MGM is installed) if audio riser fails ^{5, 6}	Disable Local Generation of Evacuation Tone if audio riser fails (factory default)

Table 2.3 S2 DIP Switch Settings on Distributed Audio Panel Motherboard

- 1 NFPA 72 requires that speakers used as alarm notification appliances on fire alarm systems not be used for nonemergency purposes. Consult with the Local AHJ for authorization to use background music. Only 20 watts of power can be supplied per amplifier if background music is enabled.
- 2 Background music is disabled during AC loss conditions to preserve battery power.
- 3 For ACC-25/50DAZS, Background Music is **prohibited**.
- 4 When CMD1 and CMD2 are configured for reverse polarity, the NAC cannot be Coded.
- 5 If the FC-MGM is installed, set the Message Repeat setting to Infinite (FC-MGM SW1: 6, 7 & 8 = ON) for proper operation.
- 6 For proper backup operation during riser loss conditions, the message repeat setting in the ACC-25/50ZS panel must be set to infinite (refer to the *ACC-25/50 Series Manual P/N: 51889* for additional information).

2.3 S3 - Battery Charger Switch on Distributed Audio Motherboard

This switch controls whether the ACC-25/50DA Distributed Audio Panel will charge the system batteries or if an external battery charger will be used.

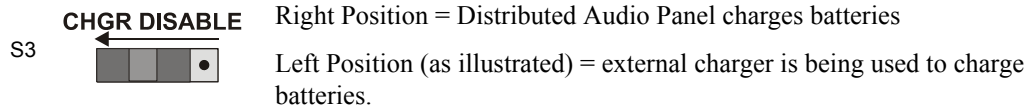

NOTE: The Distributed Audio Panel still indicates battery fault conditions even when internal battery charger is not used.

2.4 ACC-ZPM Zone Page Module

The ACC-ZPM Zone Page Module has two rotary address switches S2 and S3 which are used to set the EIA-485 address of the module for communication with the ACC-25/50ZS/T over the Zone System serial link.

2.4.1 S1 DIP Switch Settings on ACC-ZPM

S1 DIP switch is not used. *All switches are factory set to the OFF position and must remain OFF.*

2.4.2 S2 and S3 Addressing Rotary Switches

Two addressing switches are located at the bottom right of the ACC-ZPM Zone Page Module. The switches are used to set the EIA-485 address of the ACC-ZPM to allow communication between it and the ACC-25/50ZS/T. This communication link allows the ACC-25/50ZS/T to control the speaker circuits.

To set the address, use a small nonconductive flat-blade screw driver to turn the switch dial so the arrow points to the correct address number. The factory default setting is S3 = 0 and S2 = 1. The following illustration shows the switches set for address 01 with S3 (Tens) set to 0 and S2 (Ones) set to 1.

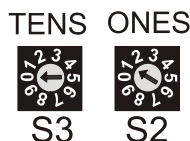

Figure 2.3 ACC-ZPM Addressing Switches

ACC-ZPM Addressing for Style Y (Class B) Audio Circuits

The ACC-ZPMK, which is located in the main ACC-25/50ZS/T Audio Panel, is set to address 01 (as illustrated in Figure 2.3) for communication with the FACP via the ACS link and will control Style Y (Class B) Audio Zones 1-8. The ACC-ZPM modules located in the ACC-25/50DAZS Distributed Audio Panels connected to the ACC-25/50ZS/T Audio Panel, must be set to consecutive addresses, starting with address 01, and will control Style Y (Class B) Audio Zones 9-16 and 17-24 as detailed in the following table.

Module	Address (S2 & S3)	Style Y (Class B) Audio Zone
ACC-ZPMK	01	1 - 8
ACC-ZPM (1st)	01	9 - 16
ACC-ZPM (2nd)	02	17 - 24



NOTE: Switch SW2 on the ACC-ZSM module is set to Class B on all ACC-ZSM(s). See 'ACC-ZSM Zone Splitter Module' on page 30.

ACC-ZPM Addressing for Style Z (Class A) Audio Circuits

The ACC-ZPMK, which is located in the main ACC-25/50ZS/T Audio Panel, is set to address 01 (as illustrated in Figure 2.3) for communication with the FACP via the ACS link and will control Style Z (Class A) Audio Zones 1 - 4. The ACC-ZPM modules located in the ACC-25/50DAZS Distributed Audio Panels connected to the ACC-25/50ZS/T Audio Panel, must be set to consecutive addresses, starting with address 01, and will control Style Z (Class A) Audio Zones 5-8, 9-12, 13-16, 17-20 and 21-24 as detailed in the following table.

Module	Address (S2 & S3)	Style Z (Class A) Audio Zone
ACC-ZPMK	01	1 - 4
ACC-ZPM (1st)	01	5 - 8
ACC-ZPM (2nd)	02	9 - 12
ACC-ZPM (3rd)	03	13 - 16
ACC-ZPM (4th)	04	17 - 20
ACC-ZPM (5th)	05	21 - 24



NOTE: Switch SW2 on the ACC-ZSM module is set to Class A on all ACC-ZSM(s). See 'ACC-ZSM Zone Splitter Module' on page 30.

2.5 ACC-ZSM Zone Splitter Module

Two switches on the ACC-ZSM Zone Splitter Module are used to configure the speaker circuits connected to it.

- SW1 - used to configure the circuits for split amplifier application. Setting the switch to the AAM 1 & 2 position directs the audio from Amplifier 1 to the first two Class A circuits or first four Class B circuits, and the audio from Amplifier 2 to the next two Class A circuits or next four Class B circuits. Setting the switch to the AAM1 position sends the audio from Amplifier 1 to all circuits. **IMPORTANT!** Set SW1 to AAM1 when Amplifier 2 is configured to backup Amplifier 1.
- SW2 - used to configure all circuits for Class A (Style Z) or Class B (Style Y) operation.

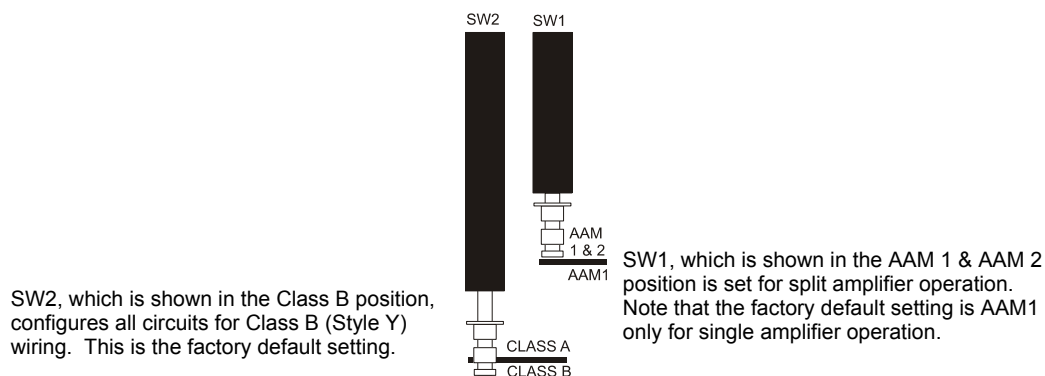

Figure 2.4 ACC-ZSM Zone Splitter Module Switch Configuration

2.6 Switch SW1 on ACC-AAM25 Audio Amplifier Module

When the amplifier is mounted in the secondary location (connector P2) on the main circuit board, switch S1 on the ACC-AAM25 is used to configure the amplifier for backup applications. Positioning switch S1 to the Up (Backup On) position sets the amplifier to act as a backup to the primary amplifier installed in the system. Positioning switch S1 to the Down position configures the amplifier to act as an additional system amplifier. See Section “Audio Amplifier Module (ACC-AAM25)” on page 46, for the location of the switch on the ACC-AAM25 board and Section “One Speaker Circuit With Backup” on page 62, for details on wiring the amplifiers for backup applications.

2.7 Switch SW1 Settings on Optional FC-MGM Module

SW1 - DIP Switch Settings

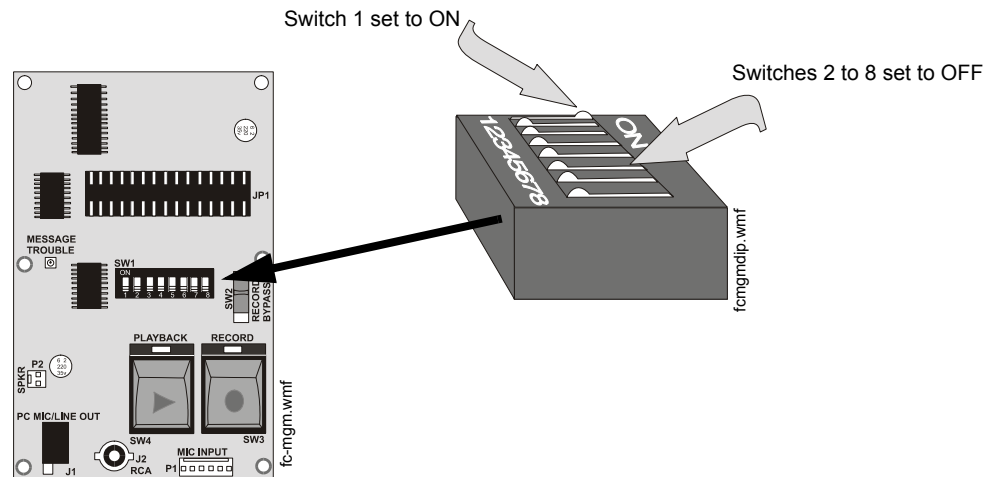

Figure 2.5 Field Programming Switches on FC-MGM Module

Custom messages can be recorded from four different audio sources:

- ✓ PC microphone
- ✓ PC line out
- ✓ Microphone (P/N:FC-MICROPHONE)
- ✓ RCA jack connected to an audio source



NOTE: Only *one* of the four audio sources can be connected at one time.

FC-MGM SW1 DIP switch settings are as follows:

- Switch 1 - used to select an input for digital voice message recording:
 - ON = select alternate sources for message recording
 - OFF = select RCA Jack for message recording (factory default)
- Switch 2 - used to configure the mini Audio Jack for digital voice message recording from either a PC microphone or a PC audio output card:
 - ON = select PC line out for message recording
 - OFF = select PC microphone for message recording (factory default)
- Switch 3 - used to enable recording of digital voice message:
 - OFF = disable recording of message (factory default)
 - ON = enable recording of message
- Switch 4 - used to determine if a tone will be generated before the message is transmitted:
 - OFF = No tone before message
 - ON = Tone before message (factory default setting)
- Switch 5 - used to determine if a tone will be generated after the message is generated:
 - OFF = No tone after message
 - ON = Tone after message (factory default setting)

- Switch 6, 7 and 8 - used to determine the number of times the voice message will repeat.

SWITCH 6	SWITCH 7	SWITCH 8	NUMBER OF TIMES TO REPEAT DIGITAL VOICE MESSAGE
ON	OFF	OFF	3
OFF	ON	OFF	3
ON	ON	OFF	6 (factory default)
OFF	OFF	ON	8
ON	ON	ON	INFINITE (until FACP trigger is reset)

Table 2.4 Switch Settings for Message Repeat

SW2 - Record Bypass Switch (on optional FC-MGM Module)

This switch, when placed in the down position, prevents accidental erasure of stored voice messages. See 'Operating Instructions' on page 52 for additional information.



•UP Position = The stored digital voice message may be overwritten with a new one.



•Down Position = The stored digital voice message can not be overwritten (factory default setting).

Section 3: Installation

3.1 Mounting

The cabinet may be surface mounted. The door is removable during the installation period by opening and lifting it off the hinges. The cabinet mounts using two key slots at the top of the backbox and two additional 0.250" diameter holes located at the bottom.

Carefully unpack the system and check for shipping damage. Mount the cabinet in a clean, dry, vibration-free area where extreme temperatures are not encountered. The area should be readily accessible with sufficient room to easily install and maintain the panel. Locate the top of the cabinet approximately five feet above the floor with the hinge mounting on the right. Determine the number of conductors required for the devices to be installed. Sufficient knockouts are provided for wiring convenience. Select the appropriate knockout(s) and pull the required conductors into the box. Note that knockouts are also located on the back of the cabinet. All wiring should be in accordance with the National and/or Local codes for fire alarm systems.

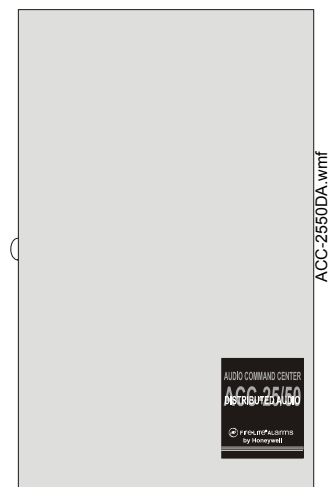

Figure 3.1 ACC-25/50DA Cabinet

3.2 Backbox Installation

Surface Mounting



CAUTION: STATIC SENSITIVE COMPONENTS

THE CIRCUIT BOARD CONTAINS STATIC-SENSITIVE COMPONENTS. ALWAYS GROUND YOURSELF WITH A PROPER WRIST STRAP BEFORE HANDLING ANY BOARDS SO THAT STATIC CHARGES ARE REMOVED FROM THE BODY. USE STATIC SUPPRESSIVE PACKAGING TO PROTECT ELECTRONIC ASSEMBLIES.

1. Open the door and lift the door off the pin hinges.
2. Remove the main circuit board and transformer from the backbox before installation. Set the board and transformers aside in a safe, clean place. *Avoid static discharge which may damage static sensitive components on the board.*
3. Mark and predrill holes for the top two backbox keyhole mounting bolts using the dimensions shown.
4. Install two upper fasteners in the wall with the screw heads protruding.
5. Using the upper 'keyholes', mount the backbox over the two screws.
6. Mark and drill the lower two holes.
7. Install the remaining fasteners and tighten all fasteners to complete backbox mounting.
8. Carefully reinstall the main circuit board and transformer, using appropriate precautions to prevent damage to components due to static discharge.

9. Draw wires through the respective knockout locations.

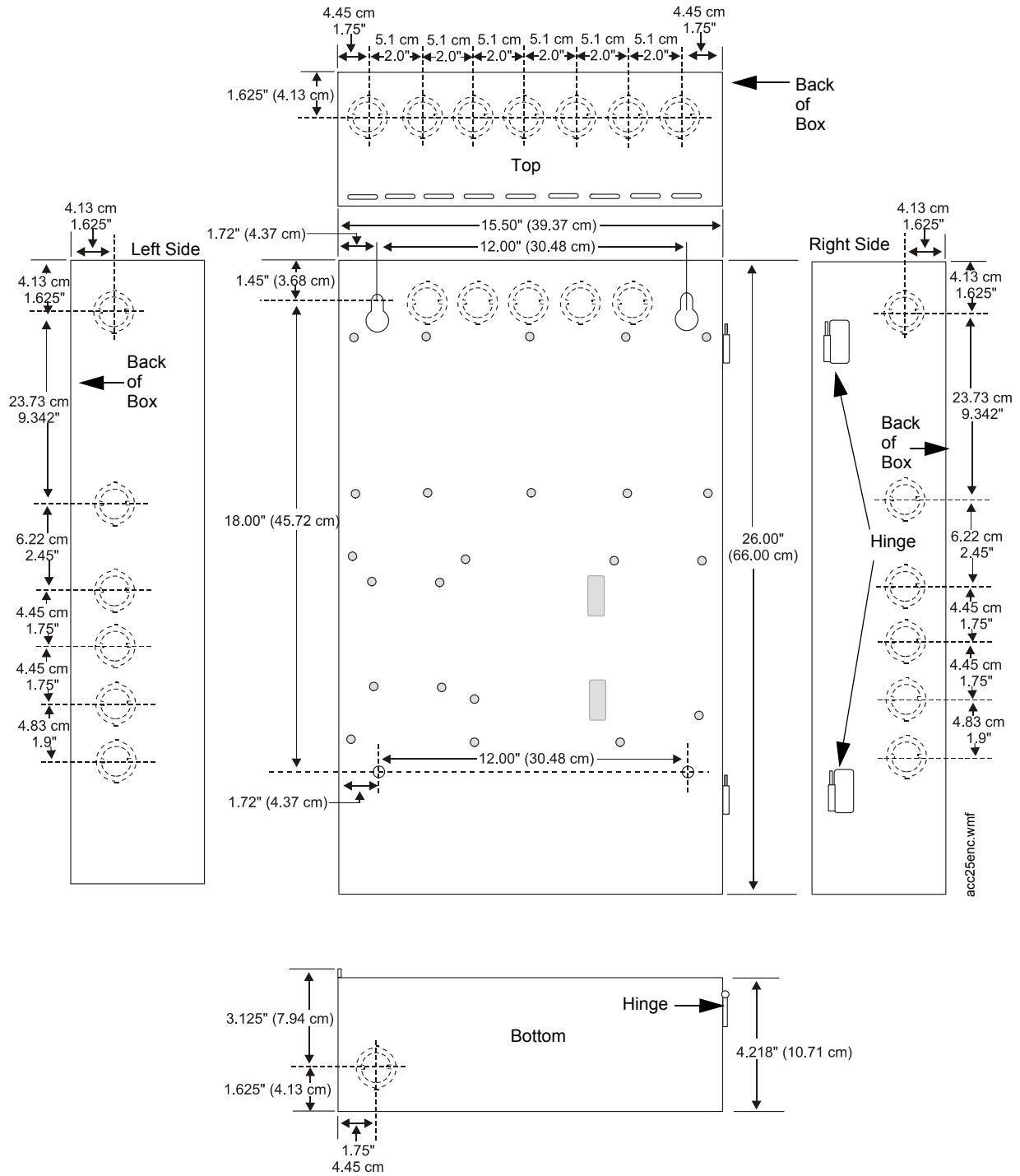

Figure 3.2 Cabinet Dimensions & Knockout Locations

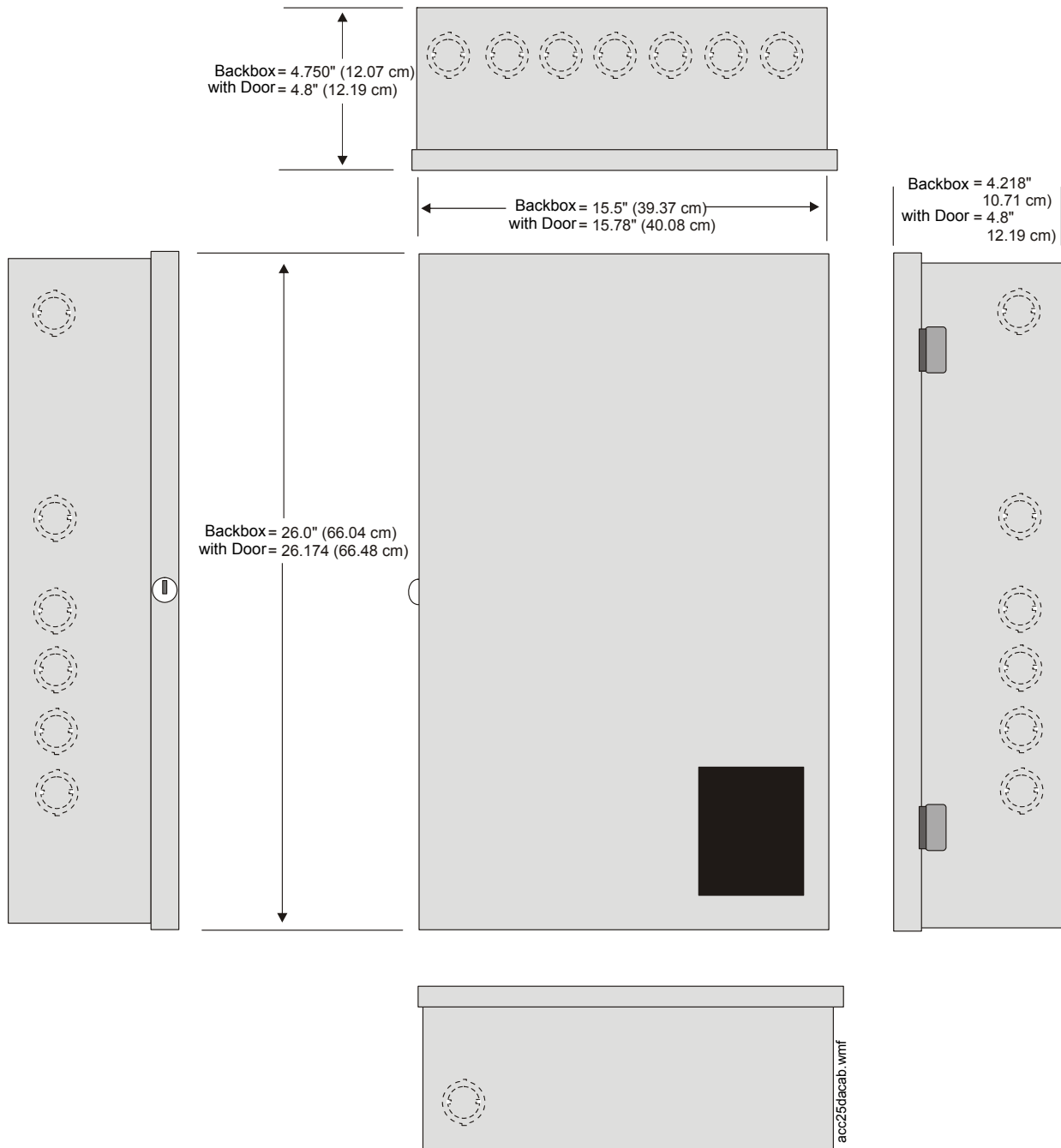

Figure 3.3 Distributed Audio Panel Backbox

3.2.1 Transformer Installation

**CAUTION: DISCONNECT POWER**

BEFORE INSTALLING ANY MODULES OR CABLES, MAKE CERTAIN ALL POWER (AC AND DC) HAS BEEN REMOVED.

1. Locate four threaded mounting studs in the bottom left corner of the backbox (refer to backbox illustration below).
2. Position the Transformer Assembly with the top and bottom mounting brackets on the mounting studs, with cable assembly oriented to the top as illustrated below.
3. Secure the Transformer to the studs with the four supplied nuts. Do not tighten one of the nuts until the next step.
4. Connect a wire from a solid earth ground to one of the Transformer mounting studs and tighten the nut. This connection is necessary in order to provide proper lightning and transient protection for the panel.
5. Plug Transformer cable assembly into connector P10 which is located in the lower left side of the main circuit board. Note that the Transformer cable connector is keyed to prevent incorrect connection.
6. Complete the installation by connecting the AC power wires to Hot, Neutral and Earth terminals of TB10 on the main circuit board.
7. If batteries are being used, connect the batteries (18 AH maximum) to connector P11 located to the bottom left of the main circuit board.
8. Apply power to the panel.

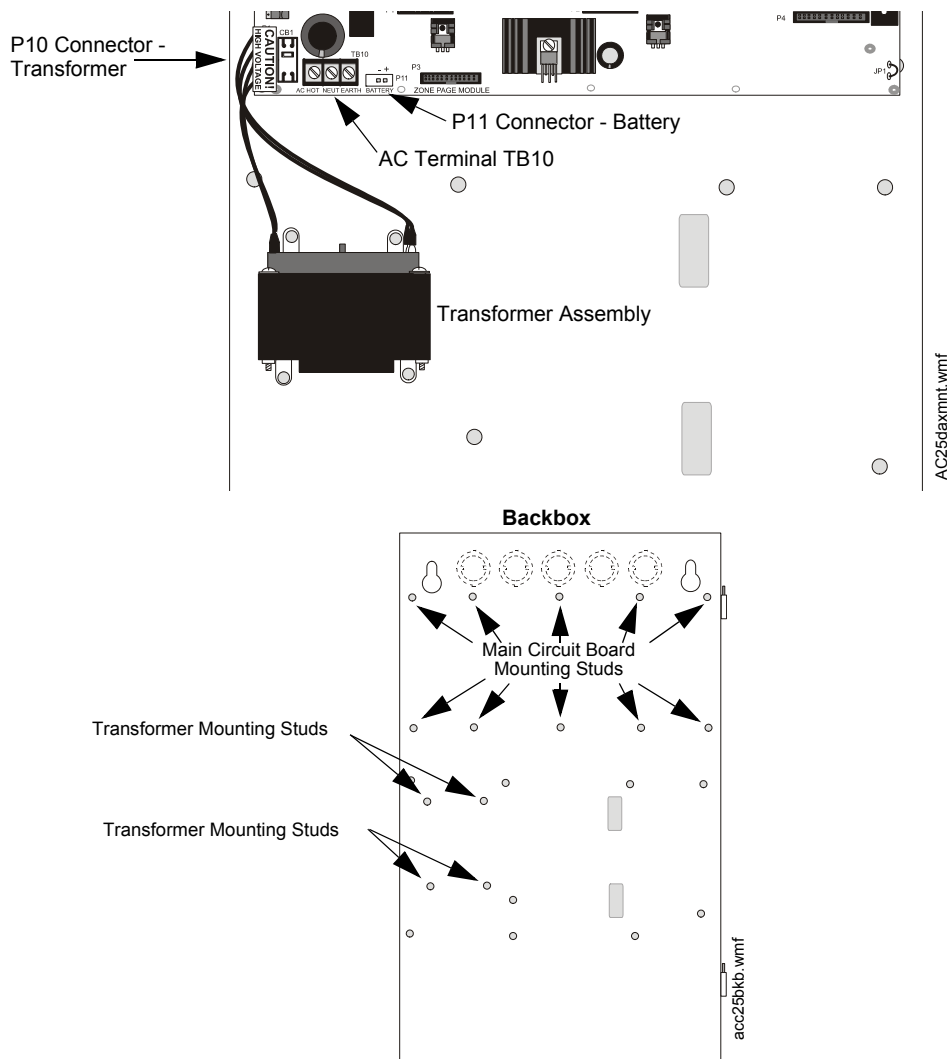

Figure 3.4 Installation of Power Supply Transformer

3.3 Operating Power



CAUTION: DISCONNECT POWER

SEVERAL DIFFERENT SOURCES OF POWER CAN BE CONNECTED TO THIS PANEL. DISCONNECT ALL SOURCES OF POWER BEFORE SERVICING. THE PANEL AND ASSOCIATED EQUIPMENT MAY BE DAMAGED BY REMOVING AND/OR INSERTING CARDS, MODULES OR INTERCONNECTING CABLES WHILE THIS UNIT IS ENERGIZED. ALSO, MANY COMPONENTS ARE STATIC SENSITIVE WHICH REQUIRE THE USE OF PROPER GROUNDING TECHNIQUES.

AC Power and Earth Ground Connection

Primary power source is 120 VAC, 60 Hz, 1.57 amp for the ACC-25/50DA & ACC-25/50DAZS. Overcurrent protection for this circuit must comply with Article 760 of the National Electrical Code (NEC) and/or local codes. Make certain that the AC mains circuit breaker is off before making any wiring connections between the mains and the panel. Run a pair of wires (with ground conductor) from the protected premises main breaker box to TB10 of the main circuit board. Use 14 AWG (1.6 mm O.D.) or heavier gauge wire with 600V insulation. No other equipment may be

connected to this circuit and it may not contain any power disconnect devices. A separate Earth Ground connection must be made to ensure proper panel operation and lightning and transient protection. Connect the Earth Ground wire (minimum 14 AWG) to one of the transformer mounting studs. Do not use conduit for the Earth Ground connection since this does not provide reliable protection.

Secondary Power Source (Batteries)

Observe polarity when connecting the batteries. Connect the battery cable to P11 on the main circuit board, using the plug-in connector and cable provided. The battery charger is current-limited and capable of recharging sealed lead acid type batteries (See Figure 3.5 for battery orientation). The charger shuts off when the system is in alarm. page 72 for calculation of the correct battery rating.



CAUTION: SULFURIC ACID

BATTERIES CONTAINS SULFURIC ACID WHICH CAN CAUSE SEVERE BURNS TO THE SKIN AND EYES, AND CAN DESTROY FABRICS. IF CONTACT IS MADE WITH SULFURIC ACID, IMMEDIATELY FLUSH THE SKIN OR EYES WITH WATER FOR 15 MINUTES AND SEEK IMMEDIATE MEDICAL ATTENTION.

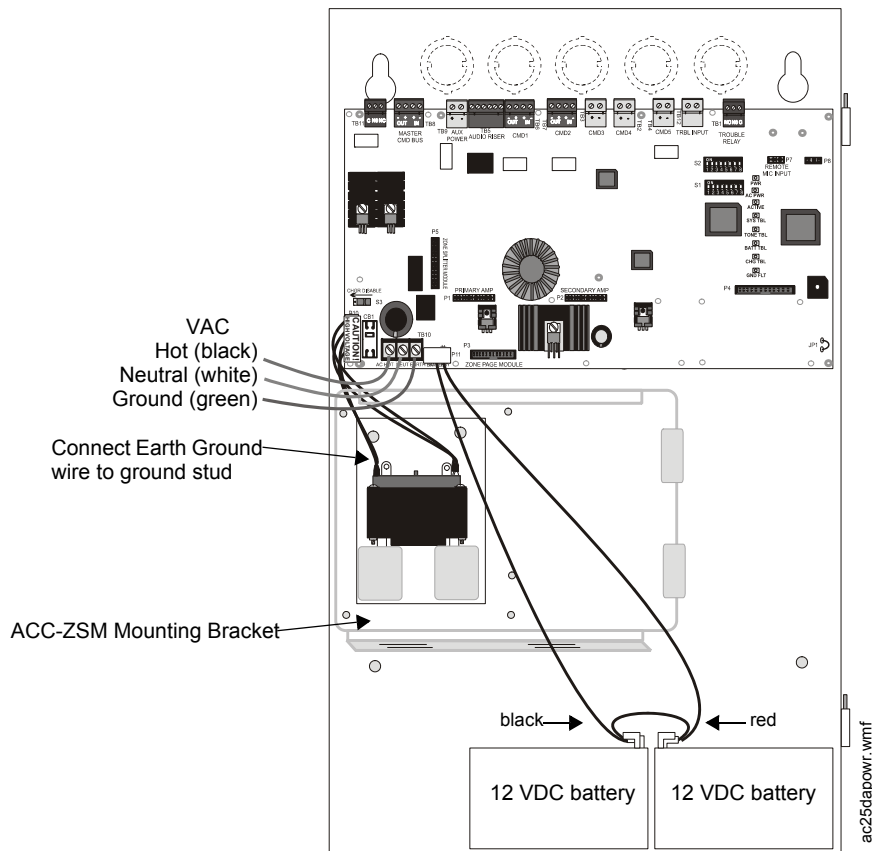

Figure 3.5 Operating Power Connections

3.4 Auxiliary DC Power Output Connections

The Special Application Auxiliary DC power output (35 mA @ 24 VDC) is power-limited, nonrettable power suitable for powering control modules and End-of Line Power supervision relays. See the *Device Compatibility Document* for compatible devices.

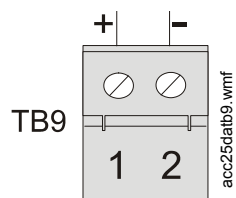

Figure 3.6 Auxiliary Power Connection

3.5 Input Circuits

3.5.1 Master Command Bus

The Master Command Bus Input circuit, when used with the ACC-25/50 Series, can be used to add paging flexibility. All field wiring for each circuit is power-limited and supervised for opens and ground faults. Note that zero impedance to ground will be indicated as a ground fault.

The Master Command Bus Input circuit is triggered by a reverse polarity signal such as the one from the Master Command Output Bus on the ACC-25/50 Series. Master Command input and output terminals are provided to allow connection to additional audio distribution panels.

When connecting the Master Command Output of ACC-25/50 Series to the Master Command Bus Input of distributed audio panels, the wiring must be supervised by a 4.7K EOL resistor connected across the out terminals of Master Command Bus Output on the last panel.

In Example 1 illustrated below, the Master Command bus is activated during paging, which routes paging audio from the riser to the Distributed Audio Panel speakers.

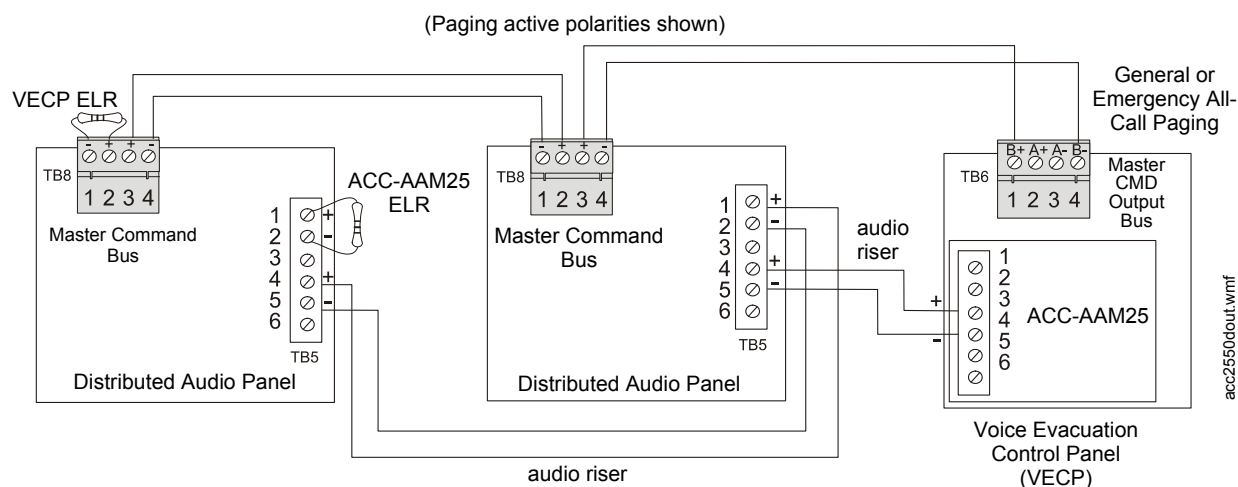

Figure 3.7 Example 1 - Activating Multiple Distributed Audio Panels with Master CMD Output Bus

The maximum line resistance from the main ACC-25/50 Series to the last Distributed Audio Panel is 130 ohms (65 ohms per conductor).



NOTE: The ACC-25/50DAZS uses the Zone System serial link for paging operations, therefore Master Command Bus connections are only used with ACC-25/50DA panels.

3.5.2 CMD Input Circuits

The Distributed Audio Panel has five Command Input circuits, which are used to activate the panel amplifiers which, in turn, transmit an audio signal over the system speakers. All field wiring for the circuits is power-limited and supervised for opens and ground faults. Note that a ground fault is indicated when there is zero impedance to ground.

CMD1 and CMD2 Command Input circuits can be independently field programmed to be triggered by a contact closure or by the reverse polarity of a Notification Appliance Circuit. (**IMPORTANT!** When CMD1 and CMD2 are configured for reverse polarity, the NAC cannot be Coded). Input and output terminals are provided for CMD1 and CMD2 to allow placement of the Distributed Audio Panel anywhere along a Notification Appliance Circuit allowing nondedicated use of host FACP NAC for triggering. CMD1 has relay contacts (maximum current 2.0 amps) before the out terminals which will open the outgoing NAC circuit during a Distributed Audio Panel trouble condition. This causes an NAC trouble at the host FACP. Note that CMD1 and CMD2 configurations can be independently set so that both circuits are triggered by the same type of input or by different types of inputs (see Figure 3.8 on page 40).

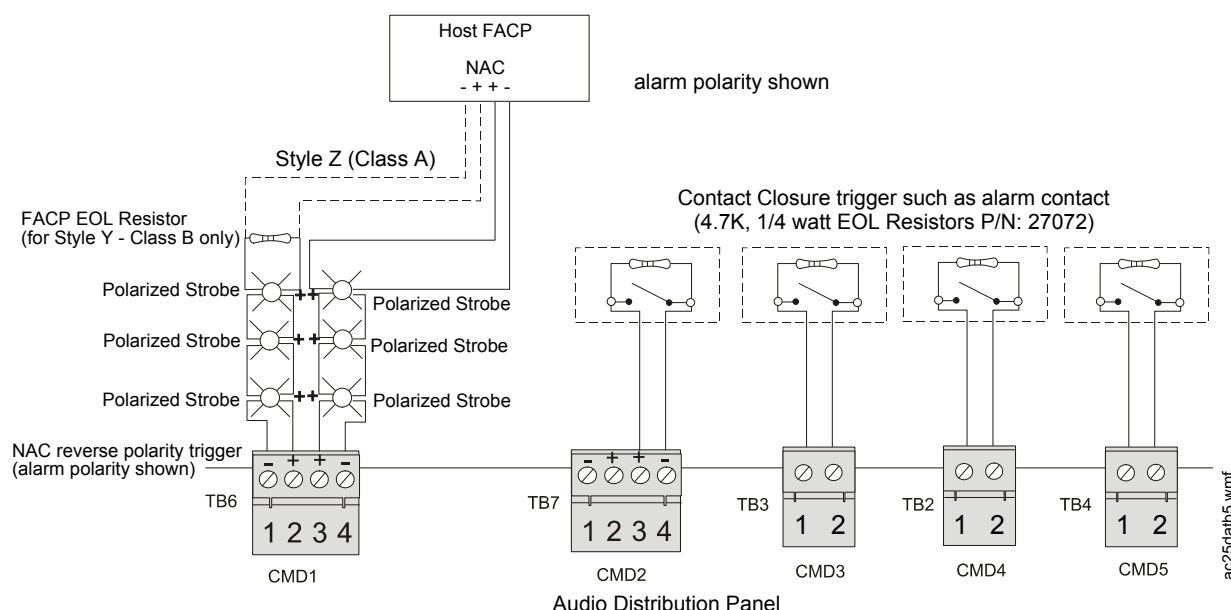

Figure 3.8 Command Input Circuits

CMD1 is programmed for reverse polarity and CMD2 is programmed for contact closure. CMD3, CMD4 and CMD5 Command Input circuits are triggered by a contact closure only.

3.5.3 Trouble Contact Input

The Trouble Contact Input is a nonsupervised, non-isolated input which can be used to monitor the trouble contacts of remote battery chargers, power supplies, etc. The maximum contact closure operation @ 30VDC current is 1.2 mA.



NOTE: Trouble Input is not suitable for AC Failure Report.

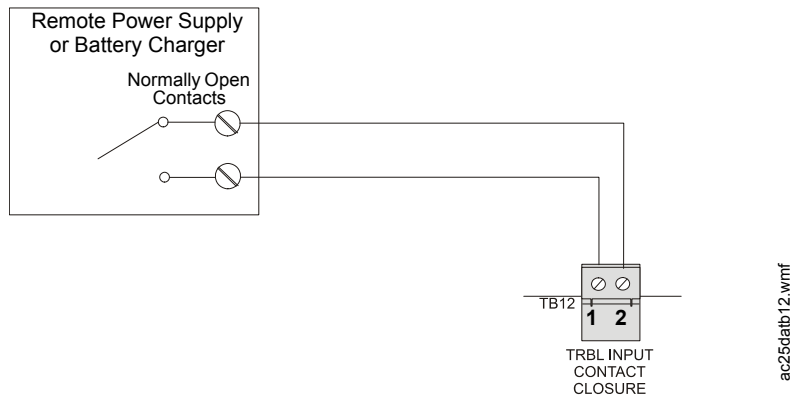

Figure 3.9 Trouble Contact Input Terminal

3.6 Output Circuits

3.6.1 Trouble Relay - TB1

The main circuit board provides a Form-C Trouble relay, for independent monitoring, rated for 2.0 amps @ 30 VDC (resistive) and 0.6 amp @ 30 VAC (resistive). This relay is ‘fail safe’, meaning that it is normally energized. Should system power shut off, this relay will deenergize, transferring its contacts.

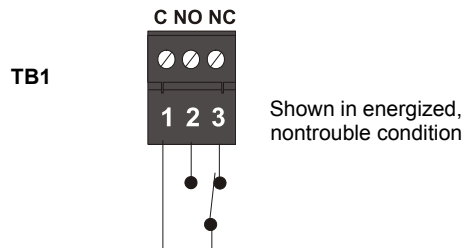

Figure 3.10 Trouble Relay

3.6.2 AC Power Loss Relay - TB11

The main circuit board provides a Form-C AC Power Loss relay rated for 2.0 amps @ 30 VDC (resistive) and 0.6 amps @ 30 VAC (resistive).

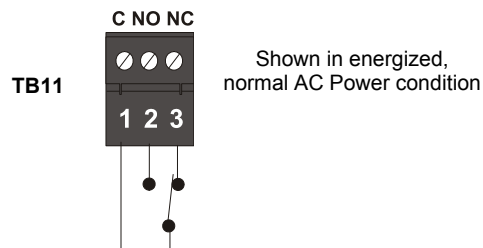

Figure 3.11 AC Power Loss Relay

3.6.3 Notification Appliance Circuit (Speakers)

Each Amplifier Module provides one Notification Appliance Circuit for speakers. The circuit can be wired Style Y (Class B) or Style Z (Class A). Each supervised and power-limited circuit is capable of 25 watts of power. The maximum total capacitance for each speaker circuit cannot exceed 250 μ F. Refer to the *Device Compatibility Document* for a listing of compatible speakers.



CAUTION: OBSERVE POLARITY

MATCH PROPER POLARITY CONNECTIONS TO FIELD WIRING AND SPEAKERS. POLARITY SHOWN IS IN THE STANDBY AND ALARM CONDITIONS.

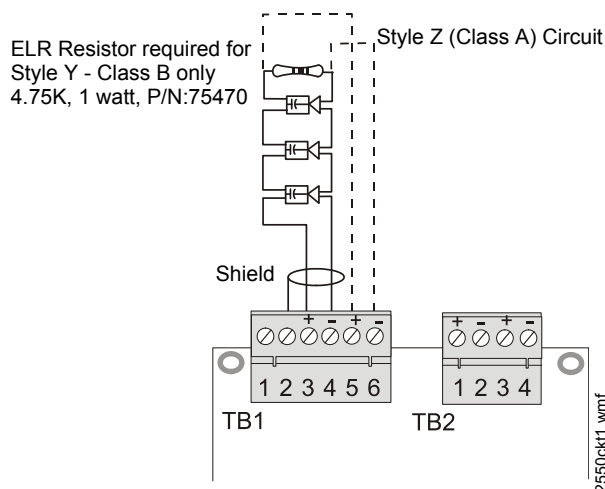

Figure 3.12 Speaker Circuit Connections

Shielded cable is not required, however, shielded cable will reduce RFI/EMI emissions and susceptibility. For additional information, refer to “Wiring Requirements” on page 78.

3.6.4 ACC-ZPM Zone Page Module - Zone System Serial Link

The ACC-ZPM Zone Page Module provides control of the speaker circuits connected to the ACC-ZSM Zone Splitter Module. In order to provide program control, an EIA-485 link must be established between the ACC-ZPM and the ACC-ZPMK located in the ACC-25/50ZS Panel. This is accomplished by wiring TB1 on the Zone Page Module to TB2 on the ACC-ZPMK. *Riser conductors must be installed in accordance with the survivability from attack by fire requirements in National Fire Alarm Code, NFPA 72.* Circuit wiring requires a ferrite bead as illustrated in Figure 3.13.

Note that the ACC-ZPM must be set to an address between 01 and 05.

3.6.5 ACC-ZSM Zone Splitter Module

The ACC-ZSM Zone Splitter Module provides connections for four Style Z (Class A) or eight Style Y (Class B) speaker circuits. Circuits are configured by setting switch SW2 on the ACC-ZSM to the Class A or Class B position (refer to Section “ACC-ZSM Zone Splitter Module” on page 30).



CAUTION: OBSERVE WIRING

FOR CORRECT SUPERVISION IN THE SPLIT AMPLIFIER CONFIGURATION, ACC-ZSM TB2 PINS 1 & 2 MUST CONNECT TO ACC-AAM25 #1 AND ACC-ZSM TB9 PINS 1 & 2 MUST CONNECT TO ACC-AAM25 #2.

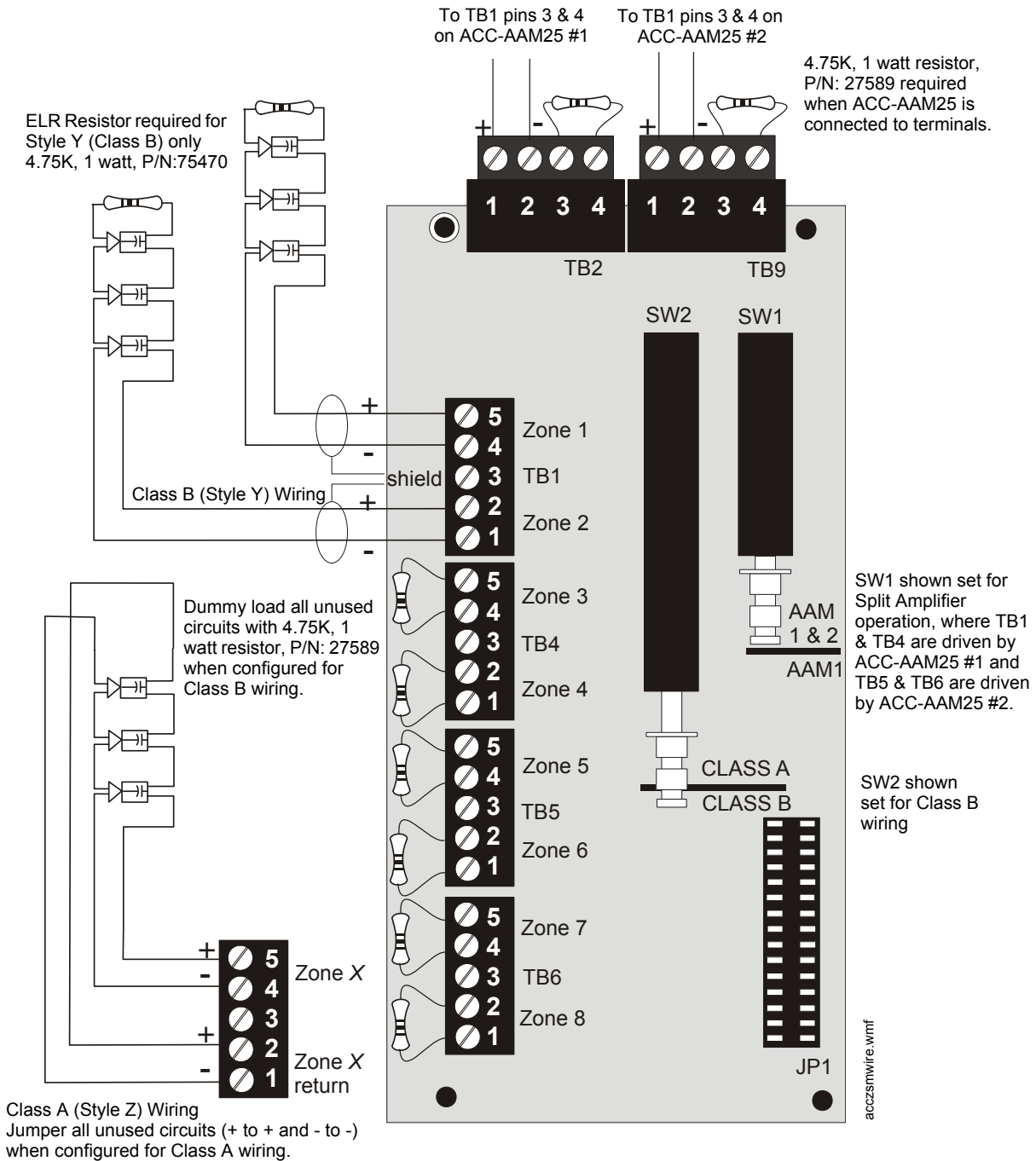

Figure 3.14 Zone Splitter Module

3.7 UL Power-limited Wiring Requirements

Power-limited and nonpower-limited circuit wiring must remain separated in the cabinet. All power-limited circuit wiring must remain at least 0.25" away from any nonpower-limited circuit wiring. Furthermore, all power-limited and nonpower-limited circuit wiring must enter and exit the cabinet through different knockouts and/or conduits. A typical wiring diagram for the Distributed Audio Panel with two speaker circuits is shown below.

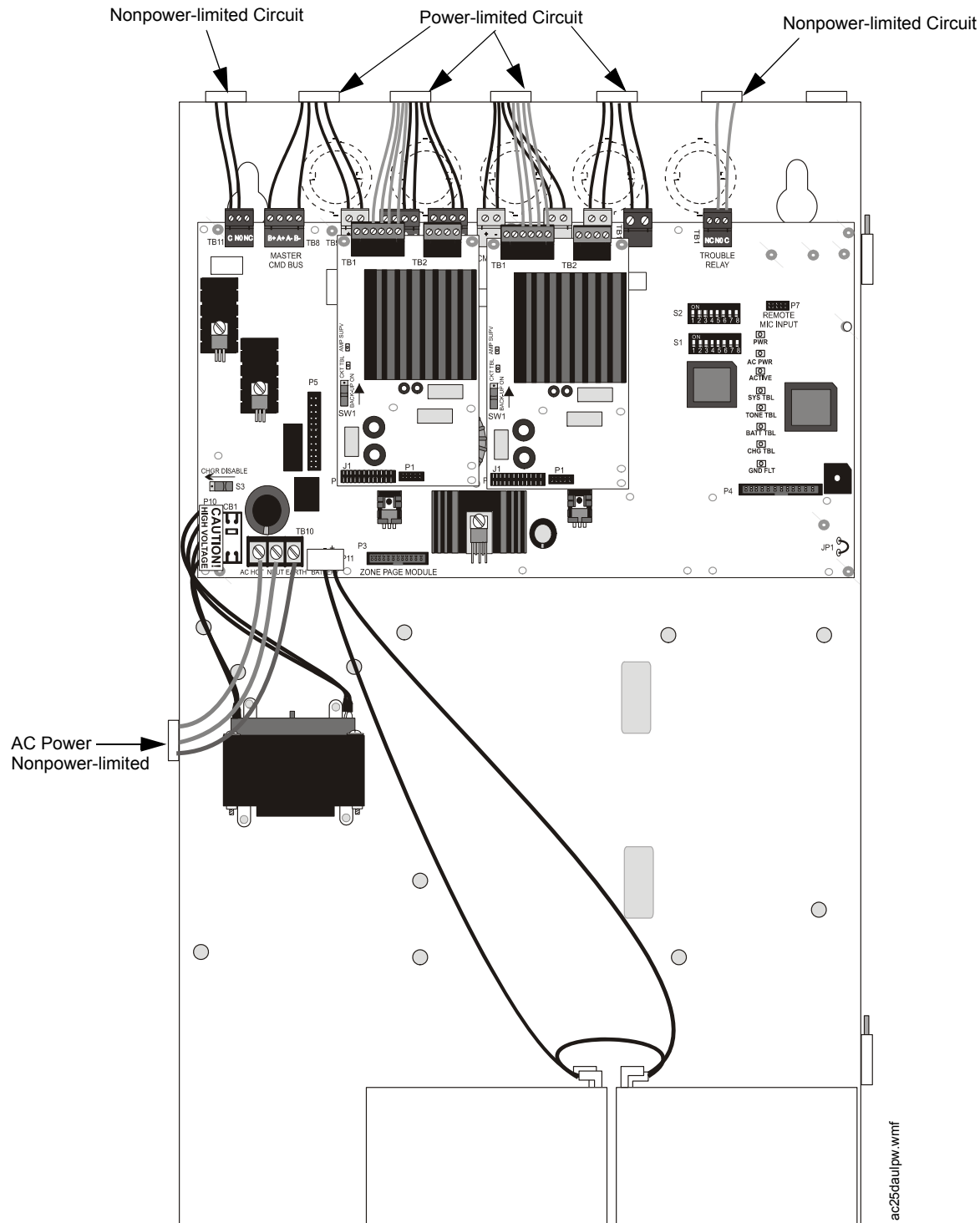

Figure 3.15 Typical Wiring Diagram for UL Power-limited Requirements

3.8 Installation of Option Modules

3.8.1 Audio Amplifier Module (ACC-AAM25)

The optional audio amplifier module is identical to the module provided with the factory standard panel configuration. It can be used to provide a second 25 watt speaker circuit, increasing the total Distributed Audio Panel power to 50 watts, or it can be used as a backup amplifier. LEDs on the amplifier module are for Amp Supervision (green - indicates amp functional) and Circuit Trouble (yellow - indicates wiring fault or amplifier fail). Connector J1 of the audio amplifier module plugs into connector P2 located at the bottom center of the main circuit board.



CAUTION: DISCONNECT POWER / STATIC SENSITIVE DEVICES

BEFORE INSTALLING ANY MODULES, MAKE CERTAIN ALL POWER (AC AND DC) HAS BEEN REMOVED. IN ADDITION, CIRCUIT BOARDS CONTAIN STATIC-SENSITIVE COMPONENTS, THEREFORE MAKE CERTAIN PROPER GROUNDING PROCEDURES ARE FOLLOWED.

1. For ease of access, all wiring should be connected to the terminals on the main circuit board terminal blocks prior to installing the secondary Audio Amplifier Module.
2. Remove mounting screw shown, from the main circuit board, and save (refer to illustration below).
3. Install one supplied metal standoff in location from which mounting screw was removed in Step 2.
4. Install the Audio Amplifier Module by carefully aligning the amplifier's J1 connector with the P2 connector on the main circuit board. Press the Module securely into place making certain not to bend or break any connector pins.
5. Secure the Audio Amplifier Module with the supplied screws plus the screw removed in Step 2. It is important to secure the module with the metal screws in order to help protect against electrical transients.
6. Configure the Audio Amplifier for primary or backup amplifier operation by setting switch S1 on the amplifier:
 - (1) Position switch S1 in the DOWN position for primary operation which adds the new amplifier's 25 watts to total system power (50 watts total).
 - (2) Position switch S1 in the UP 'Backup On' position to configure the amplifier as a backup in the event the primary amplifier fails. **IMPORTANT!** ACC-25/50DAZS ONLY - Set SW1 on the ACC-ZSM to AAM1 for backup configuration.
7. Check to make certain the factory installed jumpers are in place on P1 of the Audio Amplifier Module(s). Do not remove unless installing the FC-XRM70 Transformer Module. See Figure 3.17 on page 48.

- Connect field wiring to newly installed amplifier. Figure 3.12 on page 42 for illustration of speaker connections if amplifier is being used to expand system power to 50 watts (i.e. providing dual 25 watt speaker circuits). Figure 5.3 on page 62 for illustration of connections if amplifier is being used as a backup.

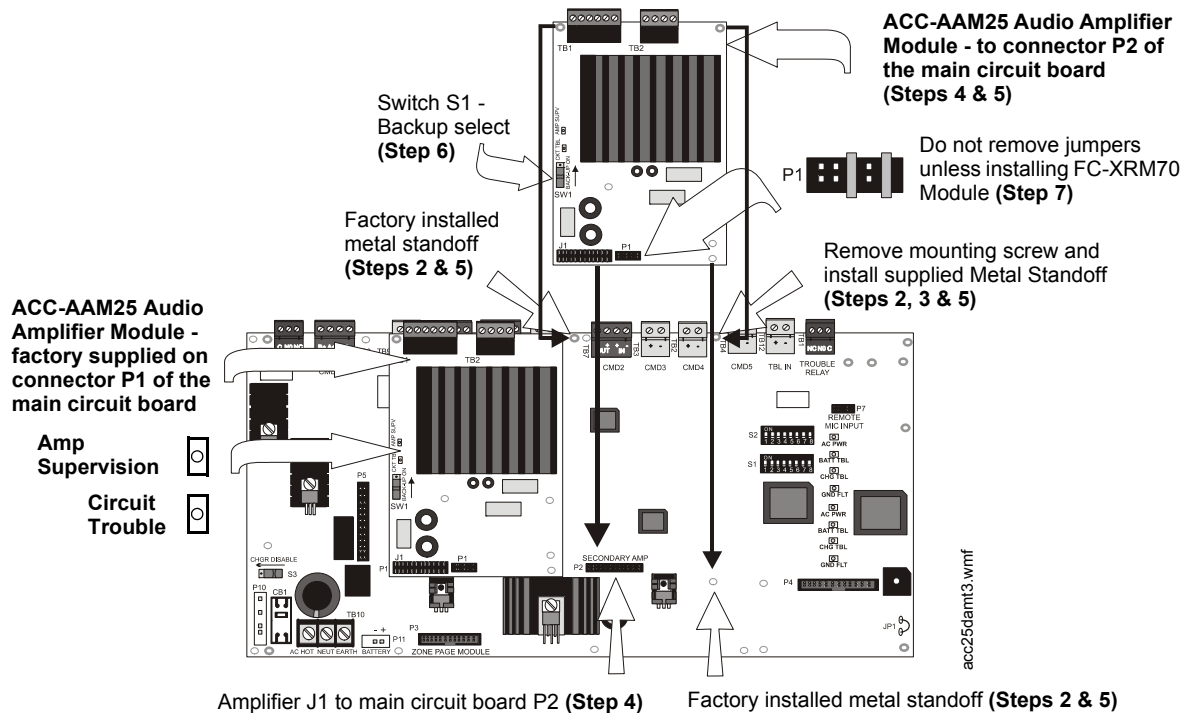

Figure 3.16 Installation of Optional Audio Amplifier

3.8.2 70.7 V_{RMS} Transformer Module (FC-XRM70)

The 70.7 V_{RMS} Transformer Module can be used to convert the 25 V_{RMS} amplifiers for installations where 70.7 V_{RMS} speakers already exist or are to be installed. Speaker wiring continues to be supervised during standby, alarm and while background music is playing when transformer is installed. Transformer connector J1 connects to amplifier connector P1.



CAUTION: DISCONNECT POWER

BEFORE INSTALLING ANY MODULES, MAKE CERTAIN ALL POWER (AC AND DC) HAS BEEN REMOVED.

- Carefully remove the ACC-AAM25 Audio Amplifier Module(s) from the main circuit board. Figure 3.16 on page 47 for installation procedures and reverse the steps.
- Install the three standoffs supplied with the FC-XRM70 Module by inserting each supplied screw into the three holes on the solder side of the ACC-AAM25 Audio Amplifier Module(s). Secure each standoff in place with the screws. Refer to Figure 3.17 for the location of the mounting holes.
- Reinstall the Audio Amplifier Module(s) following the procedure accompanying Figure 3.16.
- Remove the two factory installed jumpers from connector P1 of the Audio Amplifier Module(s). Refer to the illustration in Figure 3.17.
- Carefully align the J1 connector on the FC-XRM70 Transformer Module(s) with the P1 connector on the Audio Amplifier Module and press securely into place. Make certain the pins are properly aligned to prevent bending or breaking of pins.

- Secure the FC-XRM70 Transformer Module(s) to the Audio Amplifier Module(s) with the supplied screws.

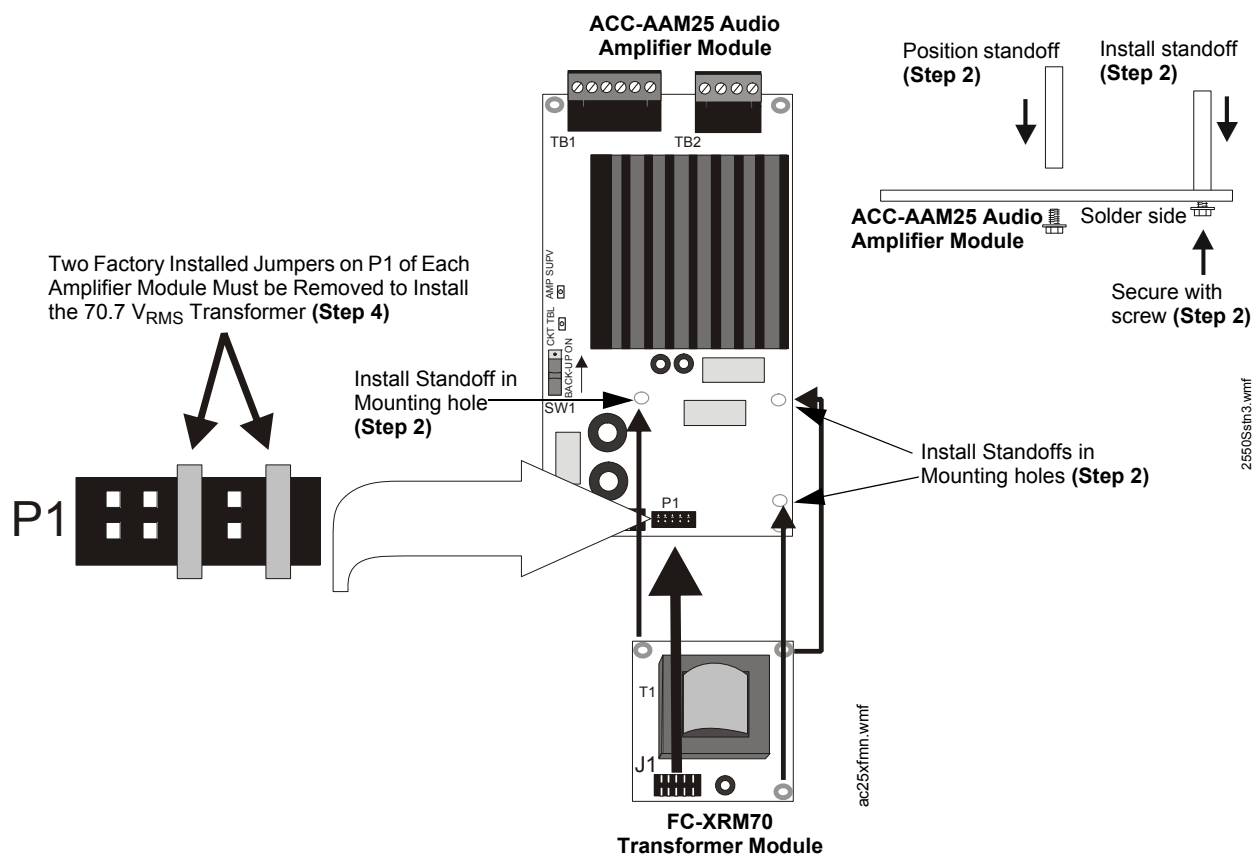

Figure 3.17 70.7 V_{RMS} Transformer Module Installation

3.8.3 FC-MGM Message Generator Module

The optional FC-MGM Message Generator Module connects to the distributed audio panel by plugging JP1 into connector P4 which is located in the lower right section of the main circuit board. The FC-MGM provides local primary or backup message capabilities. The factory programmed voice evacuation message can be changed in the field by connecting a microphone, a tape player to the RCA Jack or a personal computer audio card output to the mini Jack resident on the FC-MGM. In addition, built-in tone generators can be programmed to provide a tone before and after the message or as backup on message failure. DIP switches on the main circuit board and FC-MGM module are used to program and configure the evacuation message and/or tones. Refer to “Switch SW1 Settings on Optional FC-MGM Module” on page 31, “S1 DIP Switch Settings on Distributed Audio Motherboard” on page 26 and “S2 DIP Switch Settings on Distributed Audio Motherboard” on page 28.



CAUTION: DISCONNECT POWER

BEFORE INSTALLING ANY MODULES, MAKE CERTAIN ALL POWER (AC AND DC) HAS BEEN REMOVED.

- Carefully align connector JP1 on the FC-MGM module with the pins of connector P4 on the main circuit board.
- Press the FC-MGM module firmly into place on connector P4, being careful not to bend any pins.

3. Make certain the module is properly seated on the standoffs.
4. Secure the FC-MGM with the supplied screws.

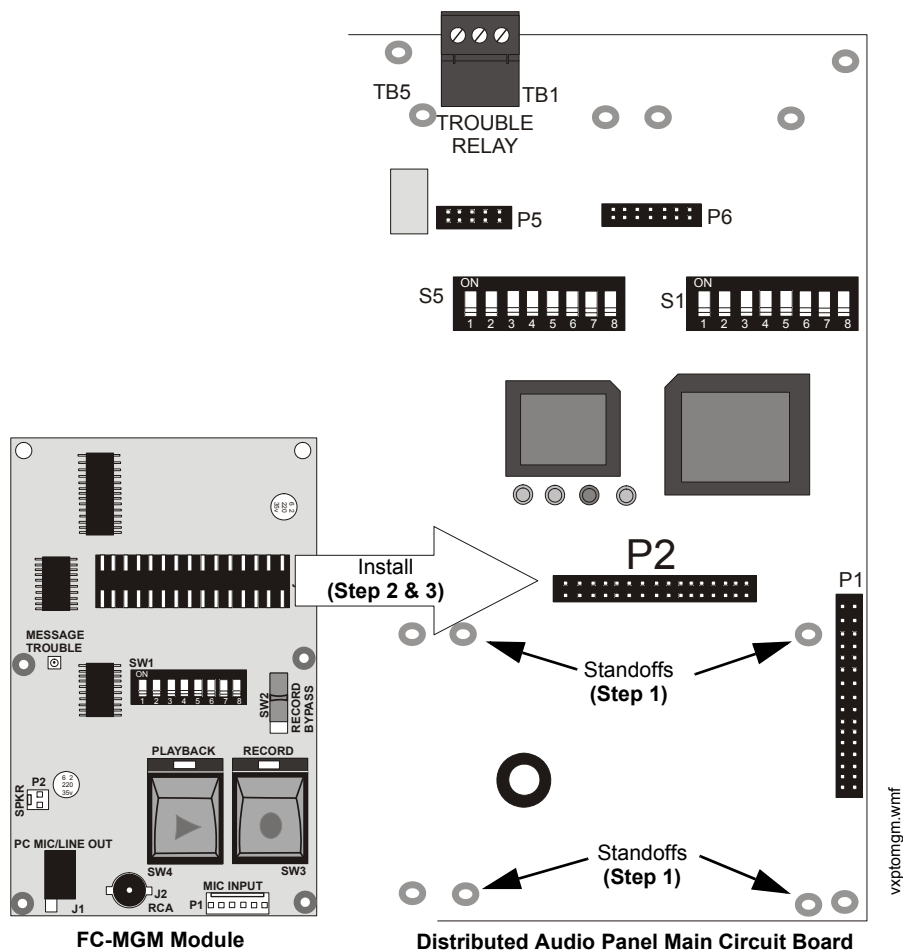

Figure 3.18 FC-MGM Module Installation

3.8.4 FC-LPS Local Playback Speaker Module

The Local Playback Speaker Module can be used to monitor the recorded digital message without transmitting the message over the system speakers. The speaker module plugs into FC-MGM circuit board. This optional module is necessary to take advantage of the Playback feature.

The Speaker Module is connected by simply plugging the module connector into P2 of the FC-MGM module. The Speaker Module may be temporarily installed during the test period.

1. Plug the FC-LPS Local Playback Speaker Module's polarized connector into connector P2 on the FC-MGM circuit board.
2. Allow the speaker to carefully hang down from the main circuit board being careful not to short any components on the board.
3. When testing is completed, remove the speaker connector from P2 on the FC-MGM.

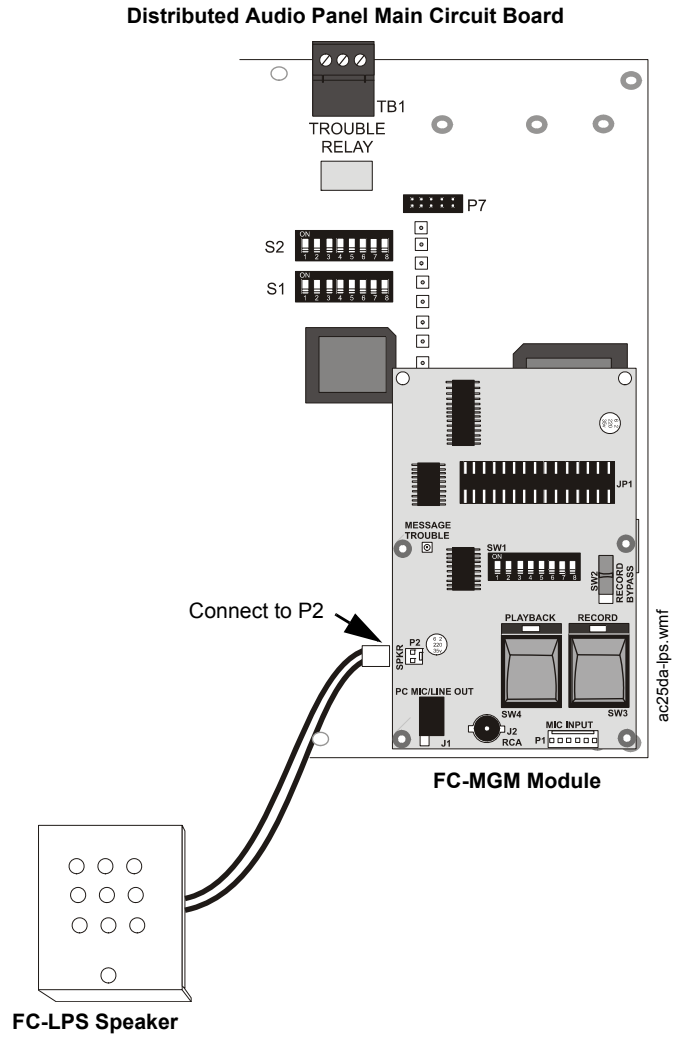

Figure 3.19 FC-LPS Installation

Notes

Section 4: Operating Instructions

4.1 Message Recording

4.1.1 Record Push Button (on optional FC-MGM Module)

The switch labeled Record is used for recording a customized message.

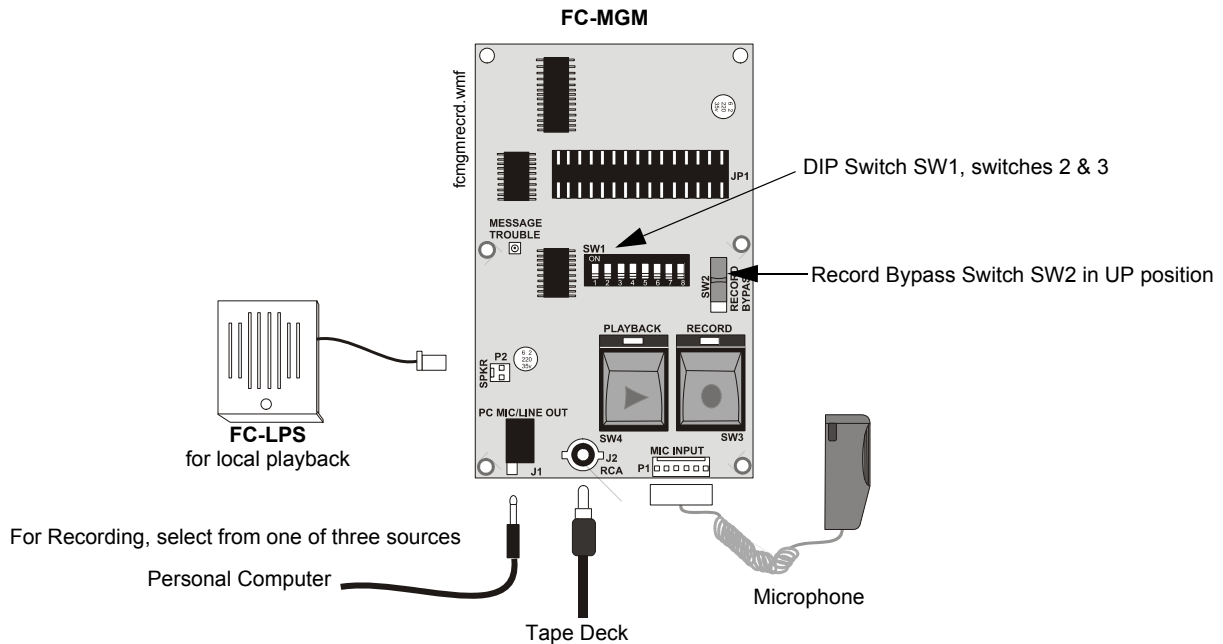

Figure 4.1 FC-MGM Recording Options

Recording Instructions

Recording a custom message into the distributed audio panel requires that the voice message be input via a microphone (P/N: FC-MICROPHONE) connected to P1 on the FC-MGM, PC microphone, PC audio out connected to J1 on the FC-MGM or another audio source connected to RCA jack J2. Switch settings in this section are for the FC-MGM module SW1 DIP switch. After recording a new voice message, wait approximately one minute for internal supervision to take place before broadcasting the new message over the building speakers.

1. Confirm the Message Control Settings On S1 DIP switches 7 and 8 located on the Distributed Audio Panel motherboard. These settings will determine the number of messages that can be recorded and the duration of each. Table 2.2 on page 27. *Note that every time these switch settings are changed, the message(s) must be rerecorded.*
2. Enable recording by setting SW1 switch 3 on the FC-MGM module to the ON position. The Record button is now ready to be used in record operation.
3. Select the record input source by setting SW1 switch 1 on the FC-MGM module to the OFF position if recording via the RCA jack, or to the ON position if recording via other sources.
4. Configure the mini audio jack, if being used, by setting SW1 switch 2 on the FC-MGM module to the ON position if recording via PC line out or to the OFF position if recording via PC microphone.
5. Slide the Record Bypass switch SW2 on the FC-MGM module to the UP position to enable the message storage device.

6. Note the following while recording:
 - During the message selection process, the Record LED will repeat a flash rate in the following manner:
 - Initial Record button press to select message #1 - ¼ second flash rate
 - Press Record button a 2nd time to select message #2 - two ¼ second flashes
 - Press Record button a 3rd time to select message #3 - three ¼ second flashes
 - Press Record button a 4th time to select message #4 - four ¼ second flashes
 - Press Record button a 5th time extinguishes the Record LED and terminates the record process
 - The total flash interval time is 9 seconds
 - To alert the user that there is only two seconds of record time remaining, the LED on the Record button will change from steady-on to flashing.
 - The System Trouble LED and Trouble Relay will be on while recording. The system will not respond to CMD inputs or Zone System serial link controls from the ACC-25/50ZS/T while recording.
 - It is not necessary to fill the entire record time. The time limits represent the maximum time allotted.
 - Factory default messages are replaced with the custom message recordings from the External Audio Input Jacks or microphone.
7. Press the button labeled 'Record' the respective number of times to select the appropriate message to record as described in Step 6. The Record LED will flash as described above. After 9 seconds, the Record LED will switch to steady on, at which point the recording of the voice message may commence.
8. At the end of recording, the Record button must be pressed again to signal the end of the recorded message. Avoid long pauses at the end of the message by promptly pressing the Record button when the voice message input has stopped. *Note that it is not necessary to fill the entire 60 second record time. The time limit represents the maximum time allotted. If the Record button is not pressed to signal the end of the voice recording, the unit automatically ends the message at the time out period.*
9. Disable recording by setting SW1 switch 3 to the OFF position.
10. Playback the recorded messages for accuracy. This may be done via the 'Playback' key or by creating an alarm or evacuate condition. The Playback feature allows for reviewing the message locally via the FC-LPS option module without generating the message through the amplifiers.



CAUTION: OBSERVE SWITCH POSITION

BE CERTAIN TO SLIDE THE RECORD BYPASS SWITCH SW2 TO THE DOWN POSITION WHEN RECORDING IS COMPLETED. THIS WILL PREVENT ACCIDENTAL RERECORDING OR DELETION OF THE STORED MESSAGE. IT IS NOT POSSIBLE TO RECORD WITH THE SW2 RECORD BYPASS SWITCH IN THE DOWN POSITION.

4.2 Playback Button

The Playback button can be used to review the stored voice message. By connecting the optional Local Playback Speaker Module (FC-LPS), the message can be heard without transmitting it over the system speakers.

Message Playback

1. Control the Message Control Settings on S1 DIP switches 7 and 8 located on the Distributed Audio Panel motherboard. These settings will determine the number of messages that can be played-back. Table 2.2 on page 27.

2. Press the Playback button to automatically start message #1. Press the Playback button a second time to fast-forward to the 2nd message, a 3rd time for message #3, and a 4th time for message #4.
3. During Playback, the following will also occur:
 - The green LED on the Playback button will be illuminated.
 - The message will play until the end or until the Playback button is pressed to advance to the next message or terminate if it's the last message.

Note that the voice message will playback only once.

4.2.1 LEDs on Main Circuit Board

Power

A green LED that remains on while DC power to the main circuit board is within correct limits. *If this indicator fails to light under normal conditions, service the system immediately.*

AC Power

A green LED that remains on while AC power is within correct limits. *If this indicator fails to light under normal conditions, check for AC power and service the system immediately.*

Active

A green LED that turns on when the system is activated into alarm.

System Trouble

A yellow LED that turns on steady to indicate a system trouble.

Tone Trouble

A yellow LED that turns on steady to indicate that the local tone generator is not functioning correctly.

Battery Trouble

A yellow LED that turns on steady when the battery is disconnected or battery voltage drops below acceptable level.

Charger Trouble

This yellow LED turns on steady when the battery charger voltage falls below an acceptable level.

Ground Fault

This yellow LED turns on steady when a ground fault condition is detected on the system. Zero impedance to ground will cause a ground fault indication.

Remote Microphone Trouble (Optional FC-MIM Microphone Interface Module)

This yellow LED turns on steady when a remote microphone trouble is detected from the FC-RM or wiring.

4.2.2 LEDs on Optional Message Generator Module (FC-MGM)

Message Generator Trouble (Optional FC-MGM)

This yellow LED turns on steady when the supervised message generator fails or falls below acceptable levels.

Record (Optional FC-MGM)

This green LED is used as a status indicator during the record process.

Playback Active (Optional FC-MGM)

This green LED turns on steady when the message generator is outputting a message.

4.2.3 LEDs on Audio Amplifier Module

Amp Supv - Supervision (Audio Amplifier Module)

This green LED (one on each amplifier), when on steady, indicates that the amplifier is fully functional. The Distributed Audio Panel constantly tests the amplifier to verify proper operation.

Circuit Trouble (Audio Amplifier Module)

This yellow LED (one on each amplifier) turns on steady when a trouble is detected in the amplifier or to indicate an open or short circuit on the field wiring attached to the amplifier output terminals.

4.2.4 LEDs on ACC-ZPM (ACC-25/50DAZS Only)

ACC COMM

This green LED remains on if communication with the ACC-25/50ZS/T main panel is active. It extinguishes if communication is lost.

4.3 Operation

The Distributed Audio Panel continuously monitors system status. When no system alarm or local trouble conditions exist, all LEDs are off except the amplifier supervision LED(s), the Power LED and the AC Power LED located on the main circuit board and the ACC LED on the ACC-ZPM module installed in an ACC-25/50DAZS. The Notification Appliance Circuits (speakers) are off and all relays are in their normal state. Zone activations and local troubles are announced by the ACC-25/50 Series panel if connected to the Distributed Audio Panel.

4.3.1 Fire Alarm

The Distributed Audio Panel will, upon detection of an alarm condition (CMD1, CMD2, CMD3, CMD4, or CMD5 Inputs active or via the ACS):

- ✓ Turn on the Active LED steady
- ✓ Turn on the appropriate Notification Appliance Circuit speakers
- ✓ Turn on the appropriate Audio Amplifier(s)
- ✓ Route audio riser or tone/message to appropriate speaker circuit

4.3.2 Fire Alarm Restoral

- ✓ Turn off the Active LED
- ✓ Turn off the Notification Appliance Circuits
- ✓ Turn off the Audio Amplifiers
- ✓ Turn off the digital voice message or tone at its present point in transmission

4.3.3 General Page Using Optional Remote Microphone (ACC-25/50DA Only)

Pressing the remote microphone push-to-talk switch will direct paging audio to all speaker circuits located at the Distributed Audio Panel.

4.3.4 Emergency Page Using Optional Remote Microphone (ACC-25/50DA Only)

Pressing the remote microphone push-to-talk switch will interrupt the tone/voice message and direct paging audio to all speaker circuits located at the ACC-25/50DA Panel.

4.3.5 Trouble Condition Response

All trouble conditions are fully supervised in standby and alarm unless otherwise noted and will cause the following to occur (note that response to AC loss will depend on the setting of S2 switch 2 as shown in Table 2.3 on page 28):

- ✓ Deenergize the trouble relay causing the contacts to transfer
- ✓ Turn on the system Trouble LED
- ✓ Open CMD1 input - ONLY if CMD1 is not in the alarm state



NOTE: If the audio panel is configured as an ACC-25/50DAZS zone system, CMD1 will not open for troubles since all troubles are transmitted from the ACC-25/50DAZS to the ACC-25/50ZS/T via the ACC control serial link

In addition to the above trouble responses, the following troubles will cause the specific responses noted:

AC Loss

- Turn off the AC Power LED on the main circuit board
- Deenergize AC Loss Relay on the main circuit board
- Deenergize Form-C Trouble and CMD1 contacts if S2 Switch 2 is OFF (refer to Table 2.3 on page 28)

Battery Trouble (low or no battery)

- Turn on the Battery Trouble LED on the main circuit board

Charger Trouble

- Turn on the Charger Trouble LED on the main circuit board

Ground Fault

- Turn on the Ground Fault LED on the main circuit board to indicate zero impedance to ground

Tone Generator Fault

- Turn on the Tone Generator Trouble LED on the main circuit board

Message Generator Trouble (optional FC-MGM)

- Turn on the Message Generator Trouble LED on the FC-MGM

CMD1 or CMD2 (Indicated by the System Trouble LED)

- Both inputs are supervised for open circuit condition when unit is programmed for Normally Open contacts, otherwise supervision is provided by the host Fire Alarm Control Panel NAC output

CMD3, CMD4, and CMD5 (Indicated by the System Trouble LED)

- All inputs are supervised for open circuit condition

Background Music

- When background music option is enabled via S2 DIP switch 3, the Distributed Audio Panel will constantly monitor the external audio riser signal. Both amplifiers and speaker wiring continue to be fully supervised when background music is output from the Distributed Audio Panel. Amplifier faults are reported after 75 seconds. Note that when AC power is lost, the Distributed Audio Panel will shut off background music to conserve batteries.



NOTE: The local Authority Having Jurisdiction must approve the use of background music. Background music is not available with the ACC-25/50DAZS.

Amplifier Fault

- Both amplifiers are constantly monitored for proper functionality. Should either amplifier fail, the AMP SUPV LED will turn off and the Circuit Trouble LED will turn on. When the system is configured for backup, failure of the primary amplifier will cause the backup amplifier to be switched in.

NAC (Speaker) Output

- The wiring to each amplifier is supervised for opens and shorts at all times in standby and while in alarm or when background music is enabled. A wiring fault will cause the circuit Trouble LED located on each amplifier module to turn on. It should be noted that the green AMP SUPV LED may remain on for wiring faults.
- The ACC-ZSM wiring to each speaker circuit is supervised for opens and shorts in standby and for shorts while in alarm. A wiring fault will cause the zone/circuit Trouble LED on the ACC-ZPMK at the main ACC-25/50 Series panel corresponding to the affected circuit to turn on.



NOTE: The local Authority Having Jurisdiction must approve the use of background music. Background music is not available with the ACC-25/50DAZS.

ACC-ZPM Zone Page Module

- The Zone System serial link wiring between the ACC-ZPM and ACC-25/50ZS/T is supervised. A loss of communication on the Zone System (EIA-485) serial link will cause a system trouble on the ACC-25/50ZS/T main panel and extinguish the ACC COMM LED.
- The ribbon cable between the ACC-ZPM and the motherboard is supervised. A loss of communication will cause the ACC Comm LED to extinguish on the ACC-ZPM module on the ACC-25/50DAZS and cause a system fault at the ACC-25/50ZS/T main panel.

Remote Microphone

- The Remote Microphone Module and associated wiring are supervised for faults by the panel.
 - ✓ The Trouble LED located on the FC-MIM Microphone Interface Module, which is mounted on the Distributed Audio Panel panel, will illuminate on a trouble condition.

Power ON LED

- A green LED that remains on while power is within correct limits. If this indicator fails to light under normal conditions, check for AC and battery power and service the system immediately.

4.3.6 Trouble Condition Restoral

All trouble condition restorals will cause the following to occur:

- Reenergize the trouble relay returning contacts to normal position
- Turn off the system Trouble LED
- Close CMD1 input

In addition to the previous trouble condition restorals, the following specific restorals will occur:

AC restoral

- Turn on the AC PWR LED on the main circuit board
- Reenergize the AC Loss Relay on the main circuit board returning contacts to normal position

Battery restoral

- Turn off the Battery Trouble LED on the main circuit board

Ground Fault cleared

- Turn off the Ground Fault LED on the main circuit board

Tone Generator restoral

- Turn off the Tone Generator Trouble LED on the main circuit board

Message Generator restoral (optional FC-MGM)

- Turn off the Message Generator Trouble LED on the FC-MGM

Amplifier restoral

- The AMP SUPV LED will turn on and the Circuit Trouble LED will turn off. When the system is configured for backup, restoral of the primary amplifier will cause the backup amplifier to be switched out.

NAC (Speaker) Output restoral

- The wiring to each amplifier is supervised for opens and shorts at all times in standby and while in alarm or when background music is enabled*. A restoral of a wiring fault will cause the circuit Trouble LED located on each amplifier module to turn off. It should be noted that the green AMP SUPV LED is on.
- The ACC-ZSM wiring to each speaker circuit is supervised for opens and shorts in standby and for shorts while in alarm. Restoral of a wiring fault will cause the zone/circuit Trouble LED on the ACC-ZPMK in the ACC-25/50ZS/T main panel corresponding to the affected circuit to turn off.



NOTE: The local Authority Having Jurisdiction must approve the use of background music. Background music is not available with the ACC-25/50DAZS.

ACC-ZPM Zone Page Module restoral

- The Zone System serial link wiring between the ACC-ZPM and ACC-25/50ZS/T is supervised. Restoral of communication on the Zone System (EIA-485) serial link will cause the system Trouble LED to turn off on the ACC-25/50ZS/T main panel.
- The ribbon cable between the ACC-ZPM and audio panel is supervised. Restoral of communication will cause the ACC Comm LED to turn on at the ACC-ZPM module on the ACC-25/50DAZS and clear the system fault at the ACC-25/50ZS/T main panel.

Remote Microphone restoral

- Turn off the Remote Microphone Trouble LED located on the FC-MIM module

Battery Charger

- Turn off the Battery Charger LED on the main circuit board

Section 5: Application Examples

The ACC-25/50DA is a Distributed Audio Panel which can be used, with a variety of Fire Alarm Control Panels, to provide emergency audio messages. This chapter contains a few application examples and is not meant to provide a comprehensive list of all possible Distributed Audio Panel applications. Please refer to the appropriate application example when following the guidelines below for installation and setup of various audio system configurations. These guidelines assume that the speaker cabling has already been connected to each ACC-25/50DA(ZS).

5.1 ACC-25/50 & ACC-25/50DA Step-by-Step Install/Setup

1. Connect the output of the ACC-AAM25 located in the ACC-25/50 to the Audio Riser Input of each ACC-25/50DA to feed the audio to each distributed panel.
2. Connect the Master Command Output of the ACC-25/50 to the Master Command Inputs of each ACC-25/50DA for All-Call paging control.
3. Connect the CMD Inputs 1-5 of the ACC-25/50 and the CMD Inputs 1-5 of each ACC-25/50DA to the FACP as required for automatic control.
4. Set S2 DIP switches on the ACC-25/50DA motherboard as required for AC Loss Reporting, Background music, CMD input trigger type, and Local Evacuation Backup.
5. Set S1 DIP switches on the ACC-25/50DA motherboard as required for Tone/Message Control. If the FC-MGM is installed, configure SW1 DIP switches for Leading/Trailing Tone and Message repeat cycle.
6. Set DIP switches 1, 2 and 3 on S3 of the ACC-25/50 motherboard for Single Zone with activation of 2-5 messages.
7. Record any new messages into the ACC-25/50ZS and the FC-MGM on the ACC-25/50DA if required.
8. Faults are monitored by the FACP via the CMD1 Relay, Trouble Relay, and AC Loss Relay.

5.2 ACC-25/50ZS/T & ACC-25/50DAZS Step-by-Step Install/Setup

1. Connect the output of the ACC-AAM25 located in the ACC-25/50ZS/T to the Audio Riser Input of each ACC-25/50DAZS to feed the audio to each distributed panel.
2. Connect the EIA-485 serial communications link wiring from the ACC-25/50ZS/T to the ACC-25/50DAZS for manual and automatic control.
3. Set the address wheels on the ACC-ZPM in the ACC-25/50DAZS for address 01-05, where ACC-25/50DAZS #1=01, ACC-25/50DAZS #2=02 and so on.
4. Set DIP switches 6, 7, & 8 on S1 of the ACC-ZPMK (in the ACC-25/50ZS/T) for operation with the number of ACC-25/50DAZS panels (1-5) installed.
5. Set SW1 on the ACC-ZSM of each ACC-25/50DAZS for one or two Audio Amplifier (ACC-AAM25) configuration.
6. Set SW2 on the ACC-ZSM on each ACC-25/50DAZS for Style Y (Class B) or Style Z (Class A) speaker circuit wiring.
7. Set S2 DIP switches on the ACC-25/50DAZS motherboard as required for AC Loss Reporting and Local Evacuation Backup.
8. Set S1 DIP switches on the ACC-25/50DAZS motherboard as required for Tone/Message Control if Local Evacuation Backup is configured. If the FC-MGM is installed, configure SW1 DIP switch for Leading/Trailing Tone and Message repeat cycle.
9. Set DIP switches 1, 2, & 3 on S3 of the ACC-25/50ZS/T motherboard for Single Zone with activation of 2-5 messages.

10. Record any new messages into the ACC-25/50ZS/T and the FC-MGM on the ACC-25/50DAZS if required.
11. Connect the ACC-25/50ZS/T to the FACP as described in the ACC-25/50ZS/T manual.
12. Faults on the ACC-25/50DAZS are uploaded to the ACC-25/50ZS/T via the Zone System Serial Link, processed, and then uploaded to the FACP via the ACS Link.

5.3 One Speaker Circuit

The base configuration of the ACC-25/50DA utilizes a single 25 watt speaker circuit.

5.3.1 Single Channel

In this application, single channel audio from the riser input is routed to the ACC-25/50DA speaker circuit. This is accomplished by using only the CMD1 input for activation.

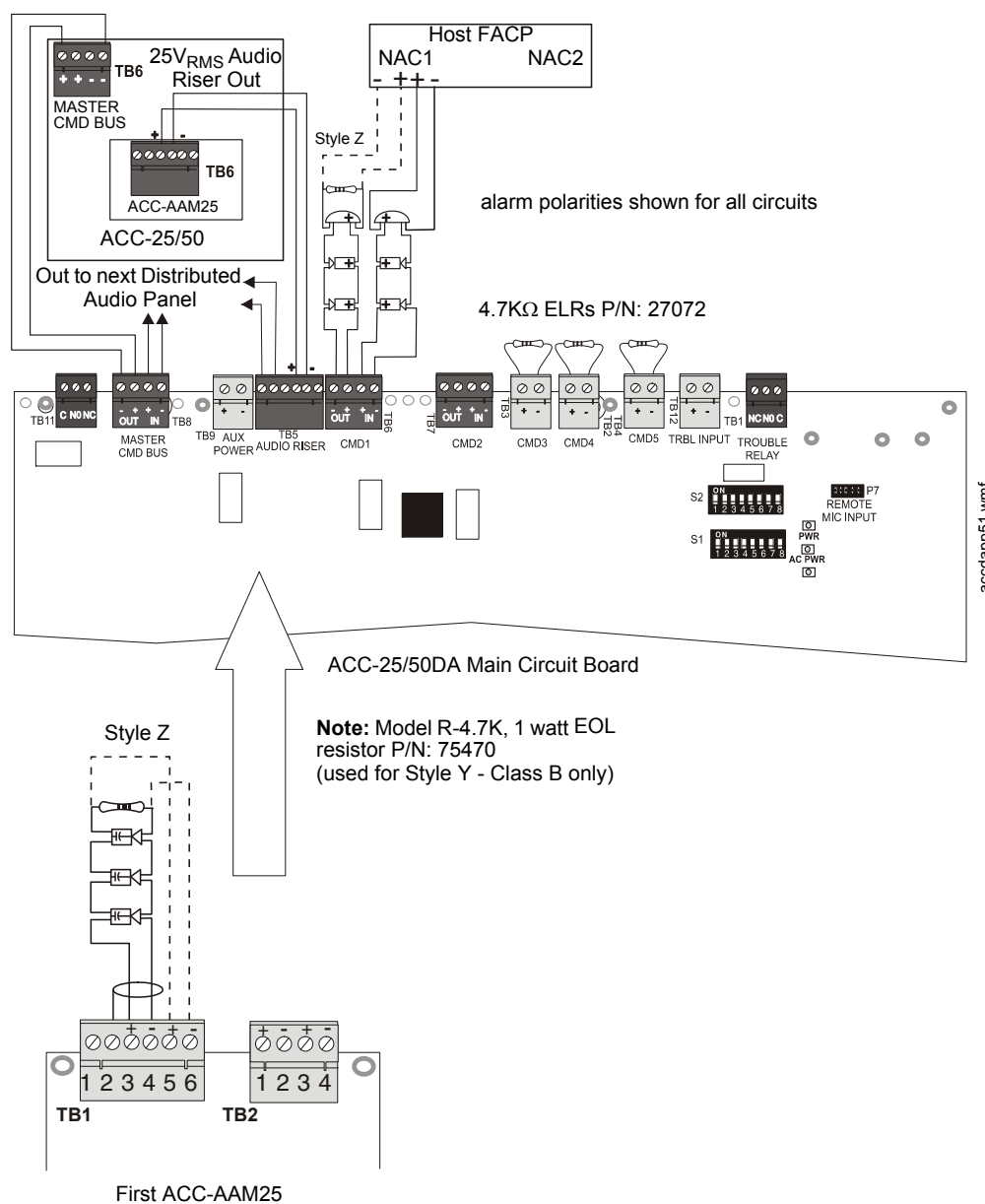

Figure 5.1 One 25 Watt Speaker Circuit - Single Channel

5.3.2 Dual Channel

This application provides two channels of input audio that can be directed to the ACC-25/50DA speaker circuit. The FACP can control the CMD1 and CMD2 inputs on the ACC-25/50DA to route riser audio from the ACC-25/50 or select the ACC-25/50DA onboard tone generator or optional message generator (FC-MGM) to be routed to the speaker circuit.

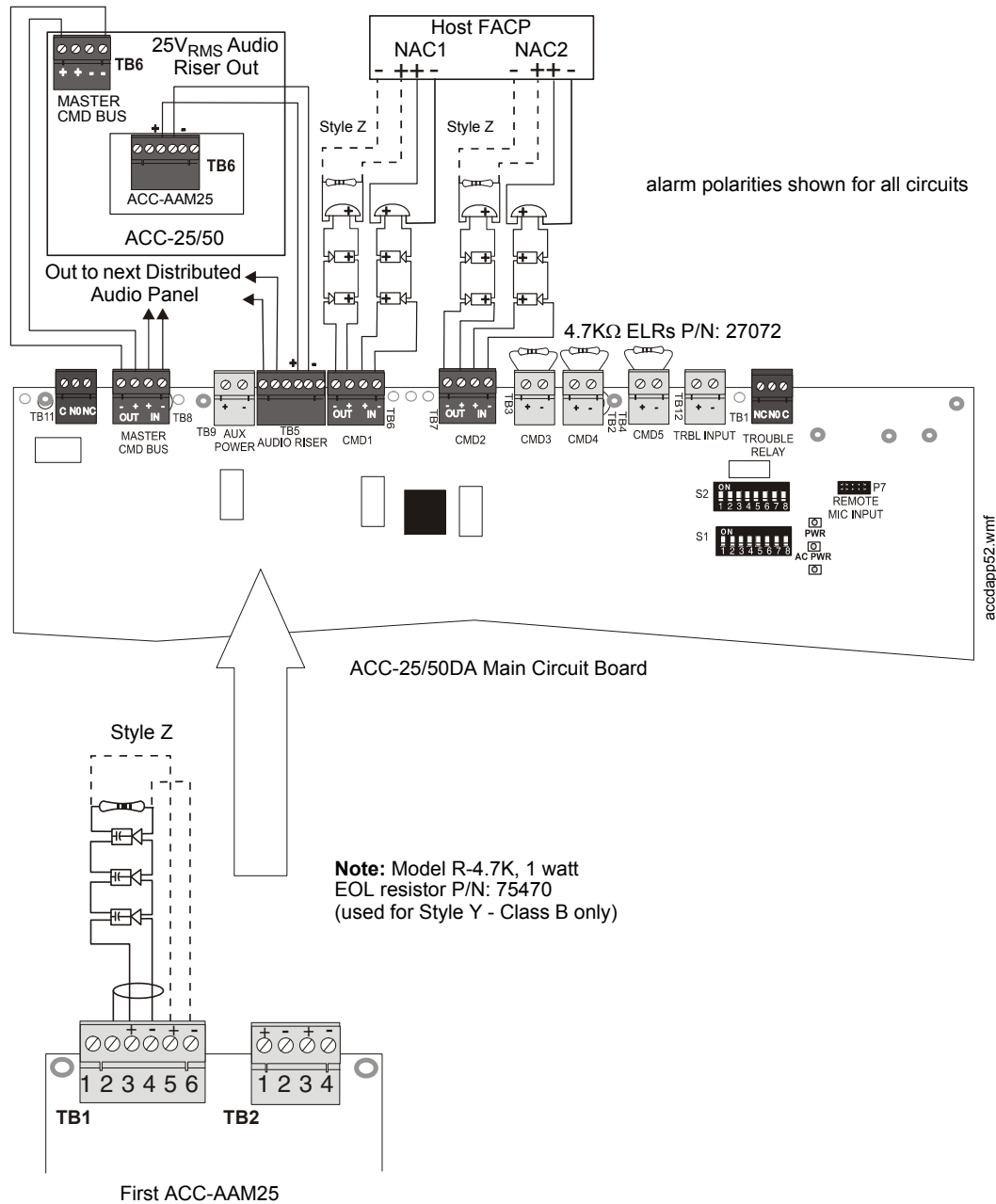

Figure 5.2 One 25 Watt Speaker Circuit - Dual Channel

5.4 One Speaker Circuit With Backup

Another application consists of one distributed audio panel with one amplifier and a single speaker circuit. A second amplifier can be installed as a backup if desired. This configuration is suitable for small area requiring no more than 25 watts of output power.

Backup Amplifier switch S1 is set to the 'Backup ON' position. 18 AWG or larger jumpers connect the Backup Amplifier TB2 Terminal 3 and Main Amplifier TB2 Terminal 1 as well as Backup Amplifier TB2 Terminal 4 and Main Amplifier TB2 Terminal 2. Upon failure of the first or main amplifier, the audio from the backup amplifier will be switched out to the speakers.

Note that in the optional 70.7 V_{RMS} configuration, only the amplifier is backed-up; the FC-XRM70 coupling transformer is not. For this reason, it is not necessary to install an FC-XRM70 transformer module on the backup amplifier.

5.4.1 Single Channel

In this application, single channel audio from the riser input is routed to the ACC-25/50DA speaker circuit. This is accomplished by using only the CMD1 input for activation.

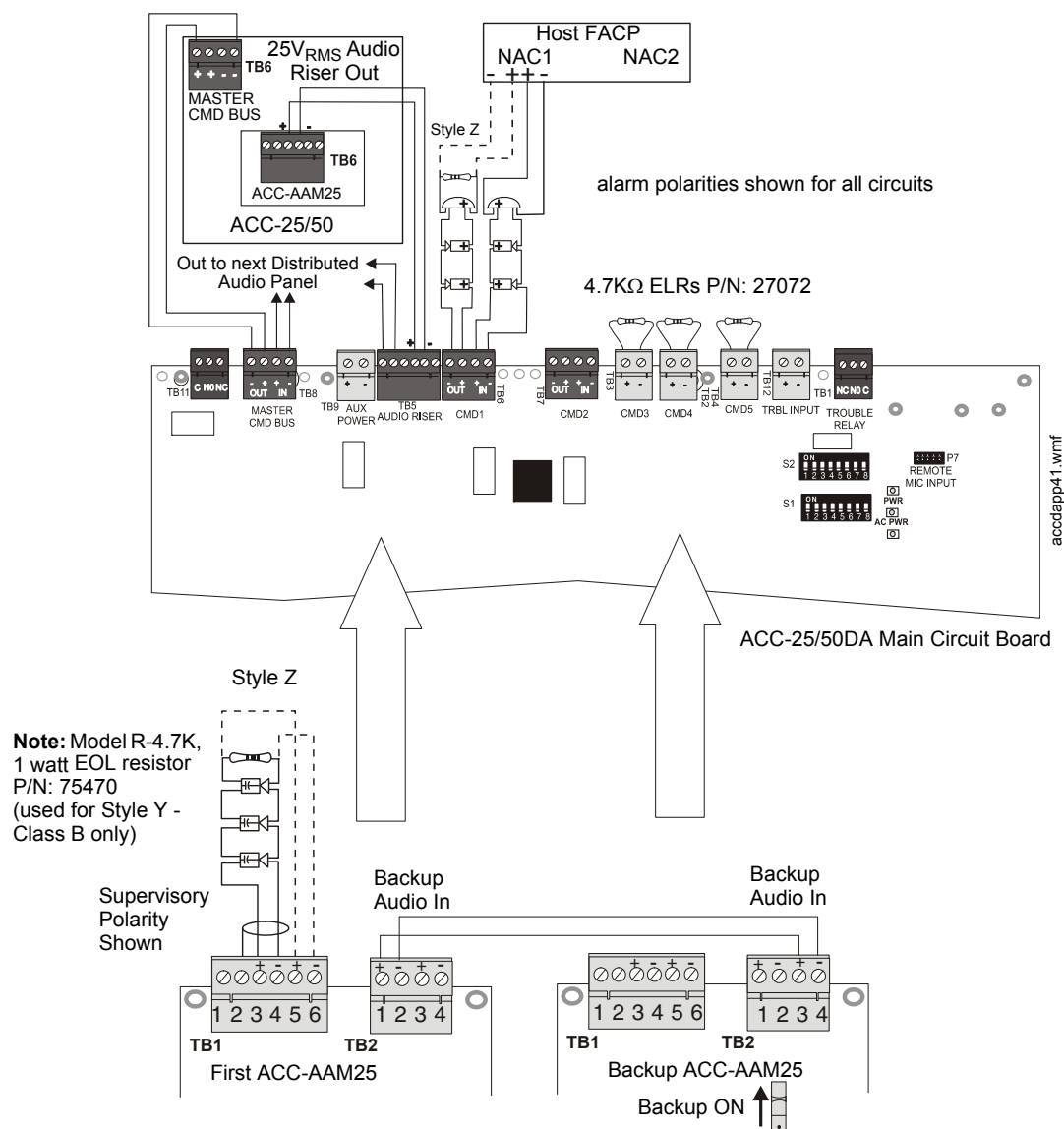

Figure 5.3 One 25 Watt Speaker Circuit With Backup - Single Channel

5.4.2 Dual Channel

This application provides two channels of input audio that can be directed to the ACC-25/50DA speaker circuit. The FACP can control the CMD1 and CMD2 inputs on the ACC-25/50DA to route riser audio from the ACC-25/50 or select the ACC-25/50DA onboard tone generator or optional message generator (FC-MGM) to be routed to the speaker circuit.

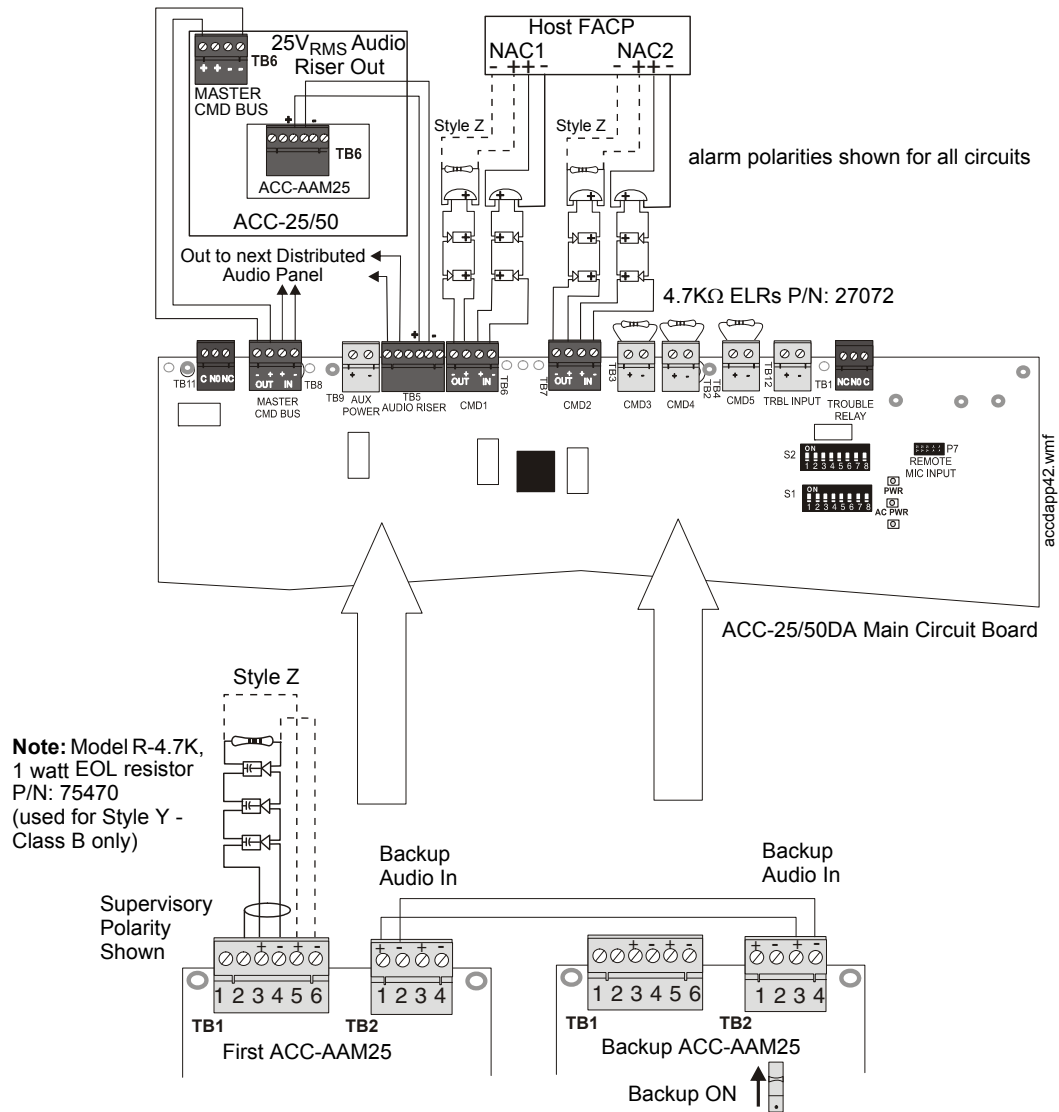

Figure 5.4 One 25 Watt Speaker Circuit With Backup - Dual Channel

5.5 Two Speaker Circuits

5.5.1 Single Channel

In this application, single channel audio from the riser input is routed to both speaker circuits on the ACC-25/50DA. This is accomplished by using only the CMD1 input for activation.

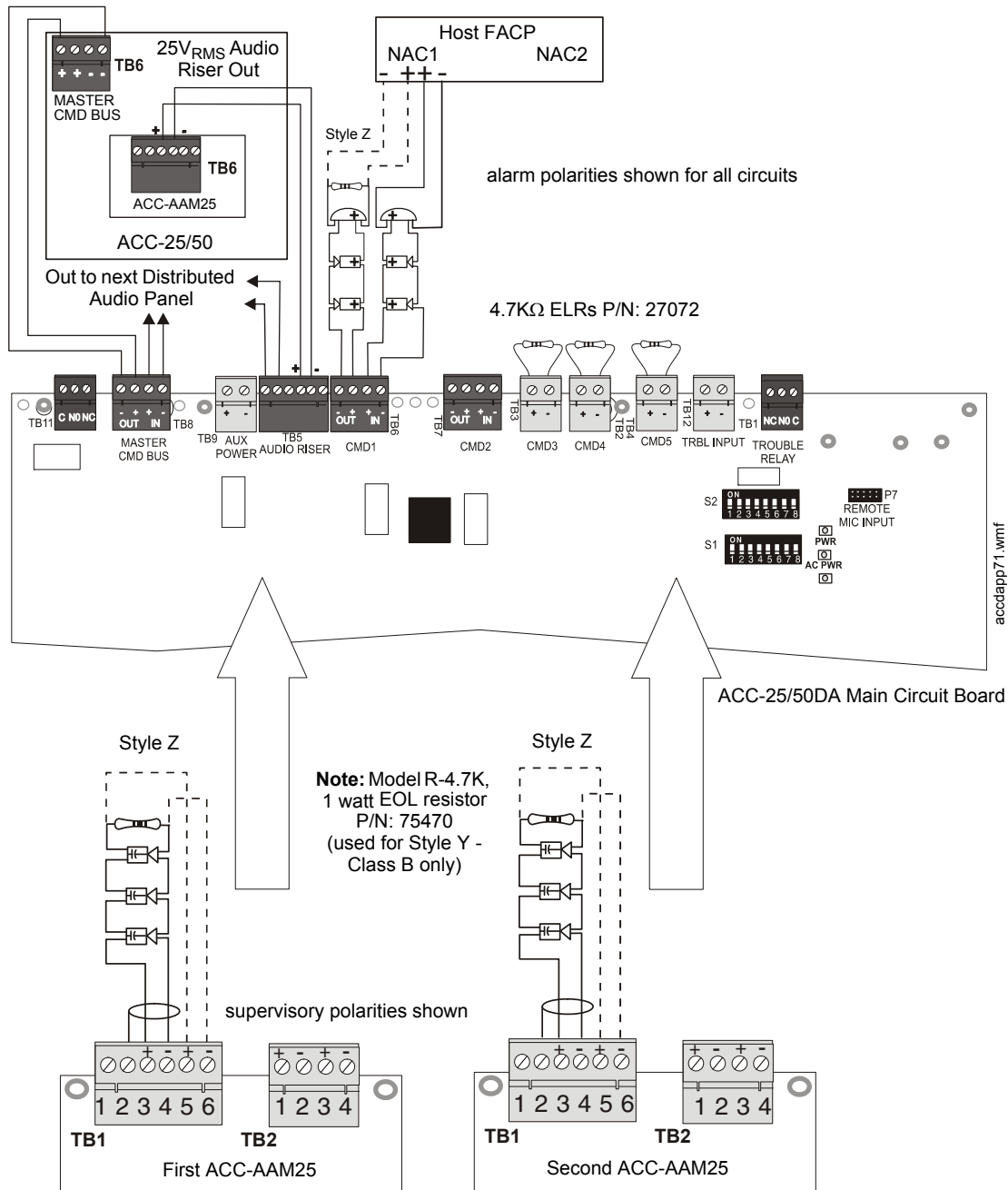

Figure 5.5 Two Speaker Circuits - Single Channel

5.5.2 Dual Channel

This application provides two channels of input audio that can be directed to both ACC-25/50DA speaker circuits. The FACP can control the CMD1 and CMD2 inputs on the ACC-25/50DA to route riser audio from the ACC-25/50 or select the ACC-25/50DA onboard tone generator or optional message generator (FC-MGM) to be routed to the speaker circuit.

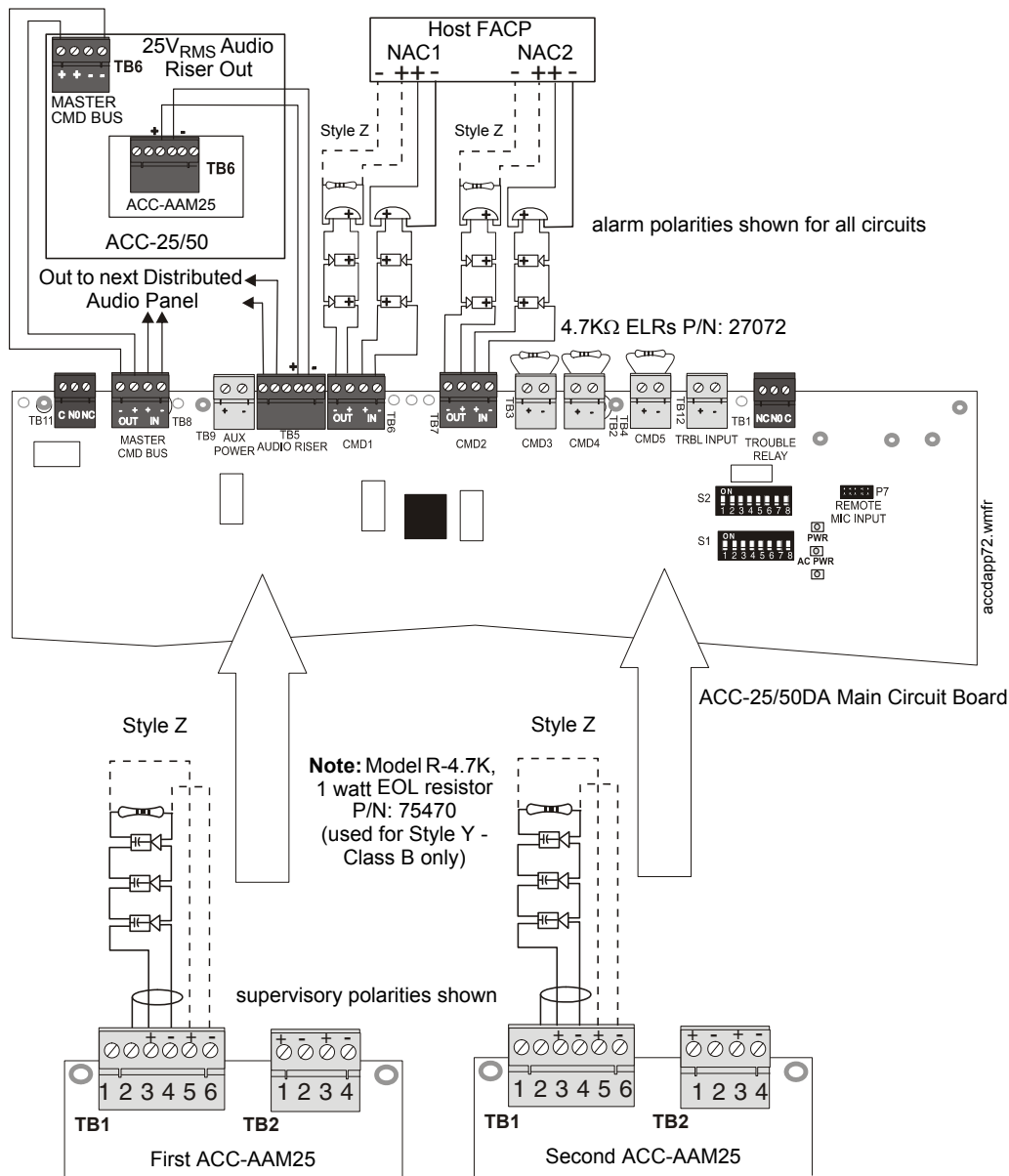

Figure 5.6 Two Speaker Circuits - Dual Channel

5.6 ACC-25/50DA High-Power, Multi-floor Application

The ACC-25/50DA panel provides *distributed* message generation:

- Fire floor selects the audio riser from the ACC-25/50
- Adjacent floors select tone/message from the ACC-25/50DA
- Master Command Bus provides All-Call Page trigger

Input Trigger	Output Trigger
CMD1	Audio Riser from ACC-25/50
CMD2	ACC-25/50DA

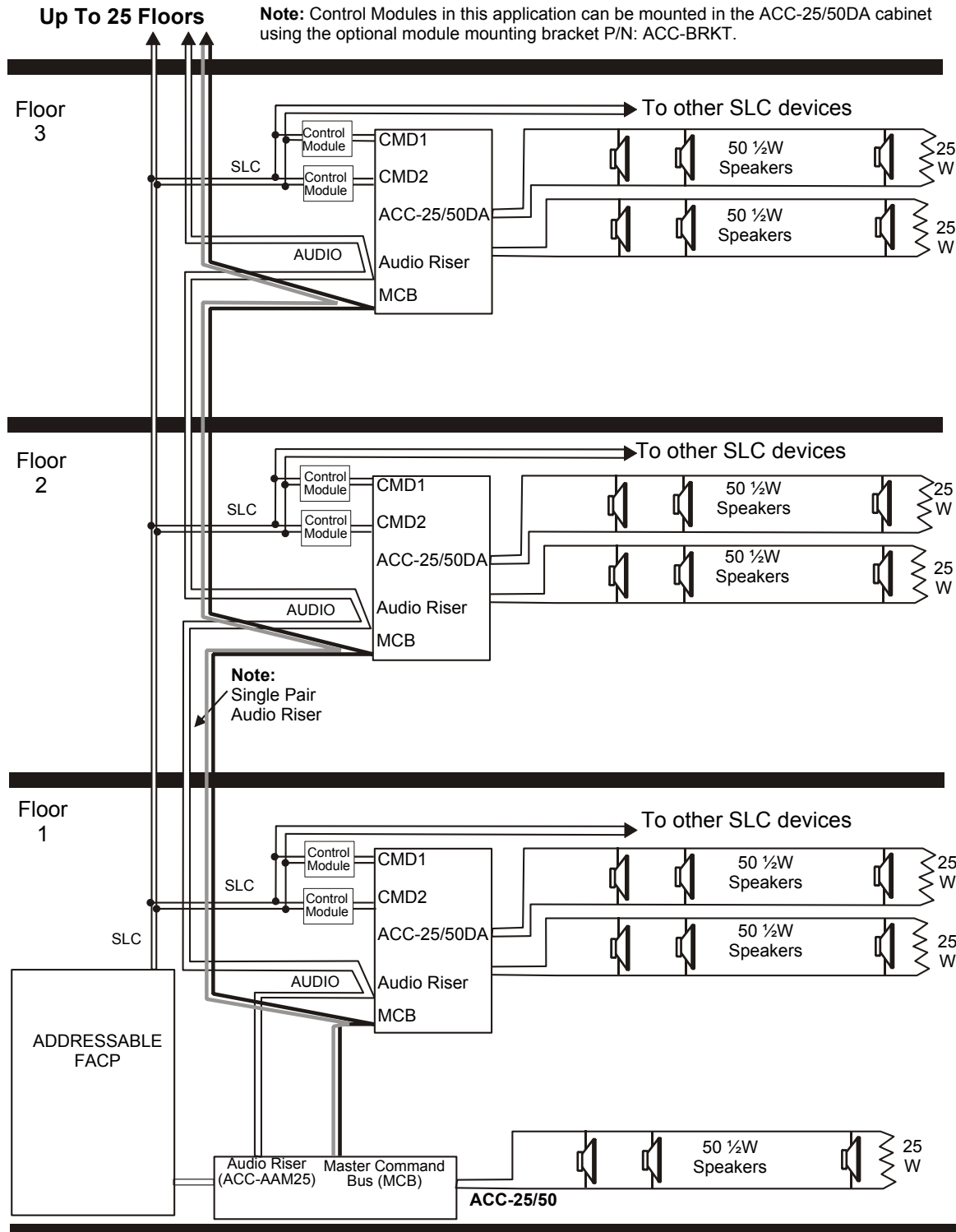

accodadis2a.wmf

5.7 ACC-25/50 Series and ACC-25/50DA Installation

ACC-25/50 Series Connection to Multiple ACC-25/50DA Distributed Audio Panels (see Table 2.2 on page 27 for Message Control switch settings and ACC 25/50 Manual Doc. 51889).

This application consists of one ACC-25/50 Series and two ACC-25/50DA panels, supplying 150 watts of output power. The addressable FACP directs one of the five voice messages to both ACC-25/50 Series speaker circuits and also manages the routing of audio in the ACC-25/50DA panels via the control modules on the SLC Loop. Audio from the first amplifier of the ACC-25/50 Series is input to the ACC-25/50DA via the audio riser.

The ACC-25/50 Series is configured for single zone operation when S3 DIP switches 1 and 3 are set to ON and DIP switch 2 is set to OFF. This causes CMD1 to activate the Fire Message, CMD2 to activate the Fire Alert Message, CMD3 to activate the Tornado Message, CMD4 to activate the Chemical Spill Message, and CMD5 to activate the All Clear Message. The FACP can route the message generated by the ACC-25/50 Series to the speaker circuits of the ACC-25/50DA by activating the control module connected to CMD1 of the ACC-25/50DA or it can select the ACC-25/50DA local message by activating the control module connected to CMD2.

All Call paging is possible by pressing the All Call button on the keypad of the ACC-25/50 Series. This will activate the ACC-25/50DA speaker circuits. Keying the microphone will allow announcements to be made on all speaker circuits.

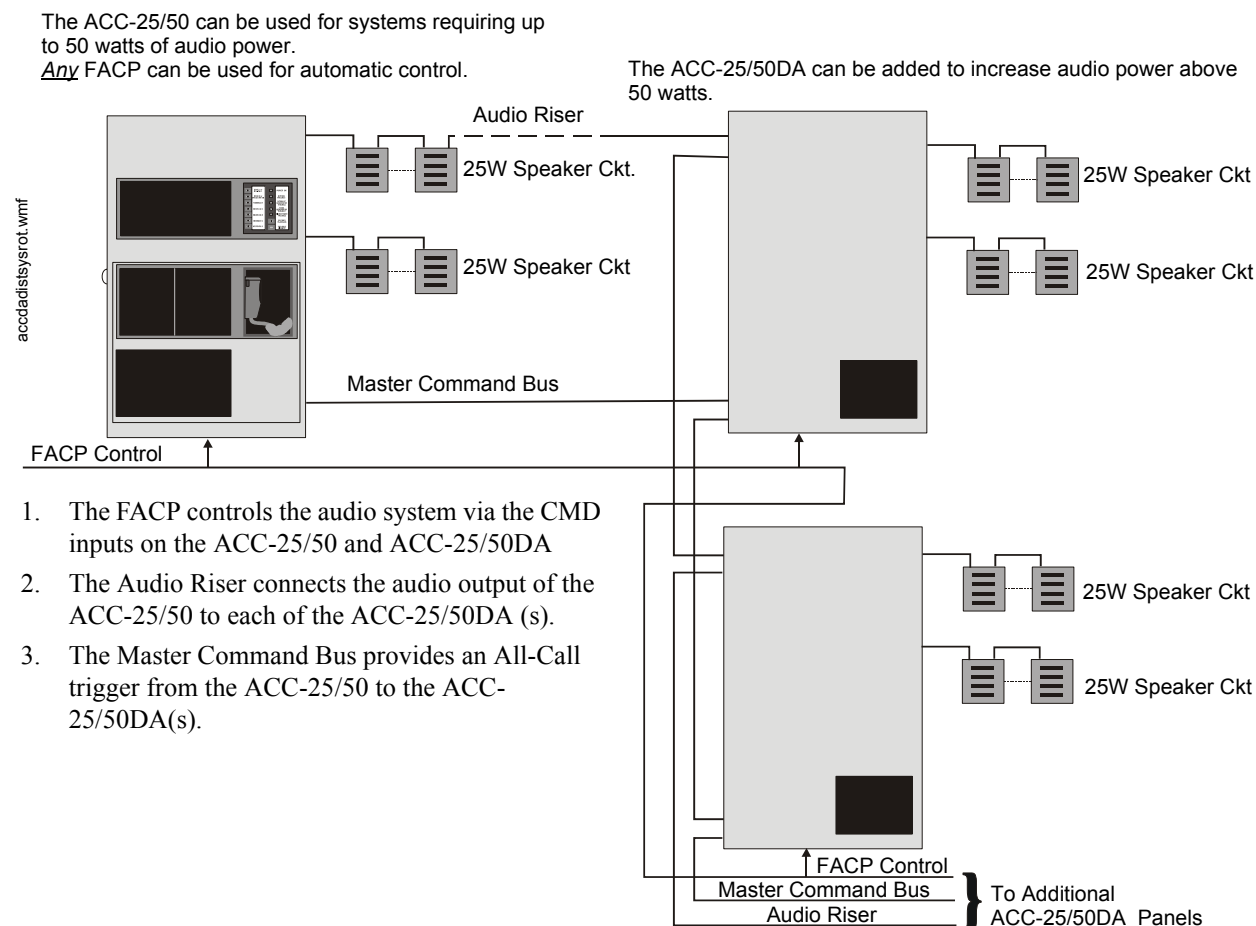
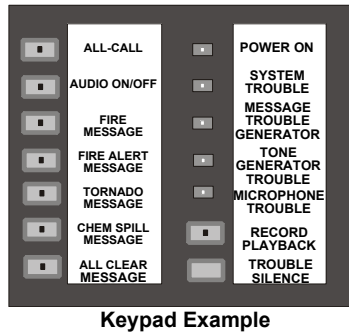

Figure 5.8 ACC-25/50DA Installation



Note: Typical illustration of an addressable control panel and addressable control modules. Refer to the Command Input Specification in Section 1.2, 'Specifications' on page 17, for the voltage range.

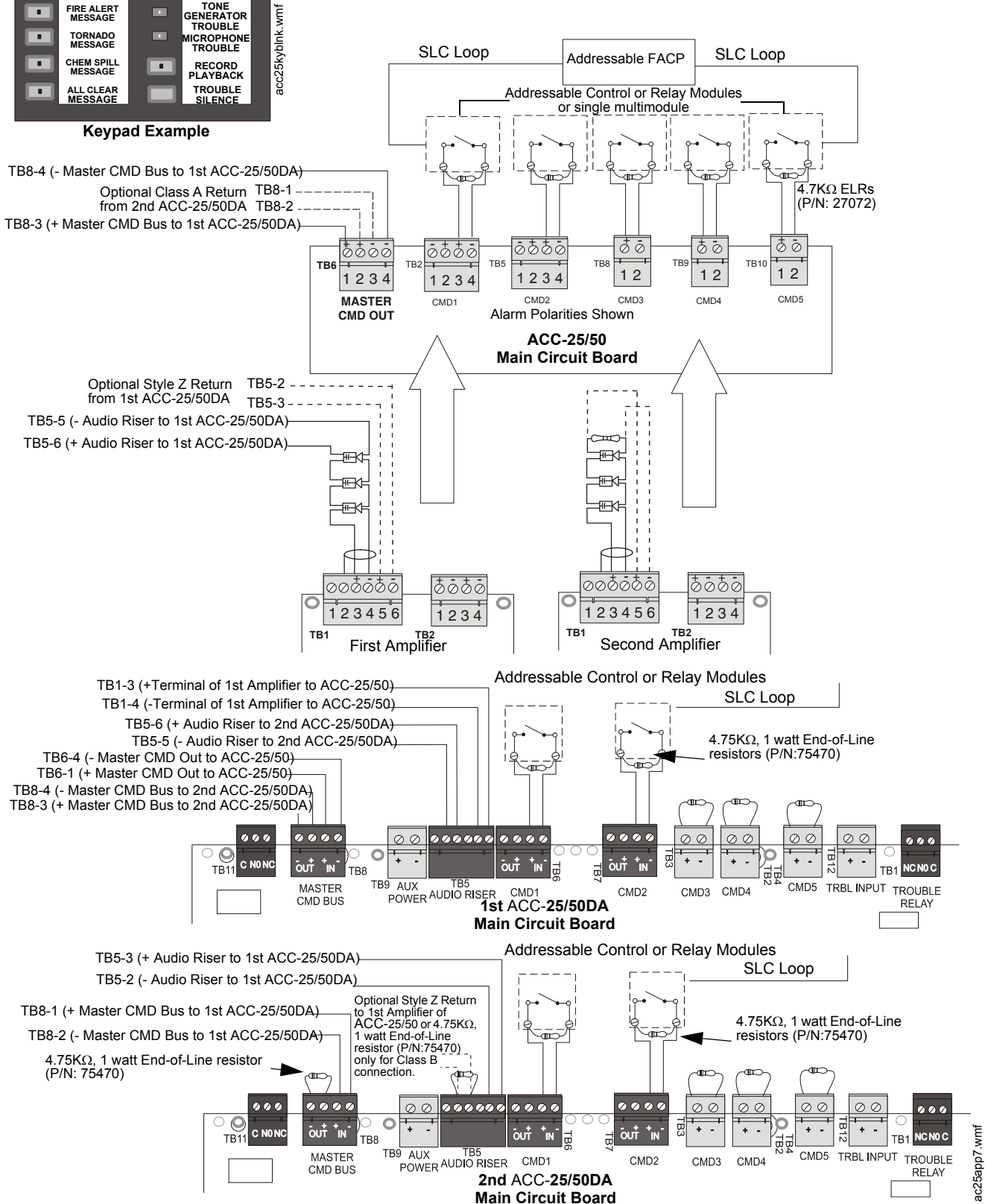

Figure 5.8 ACC-25/50 Series and ACC-25/50DA Installation

5.8 16 Theater Cineplex Utilizing ACC-25/50ZS/T

In this application, the Fire Protection System consists of one ACC-25/50ZS/T with one ACC-25/50DAZS, 16 zones and an addressable FACP. Each one of the 16 movie theaters is wired and assigned as a speaker circuit. The FACP is programmed for Software Zone 33 for Theater 1 through Software Zone 49 for Theater 16. Software Zone 32 is programmed to activate all speaker circuits (All-Call). In addition, the Fire Evacuation Message (Message #1) is entered into Software Zones 32 - 49.

Automatic control by the FACP is provided through the ACS link to the ACC-25/50ZS/T. Manual control is possible via the keypad in the ACC-25/50ZS/T. Control of Audio Zones 9 - 16 is sent through the ACC Control Serial Link to the ACC-25/50DAZS. Alarm and Paging audio from the ACC-25/50ZS/T is delivered to Audio Zones 9 - 16 (ACC-25/50DAZS) by way of the Audio Riser.

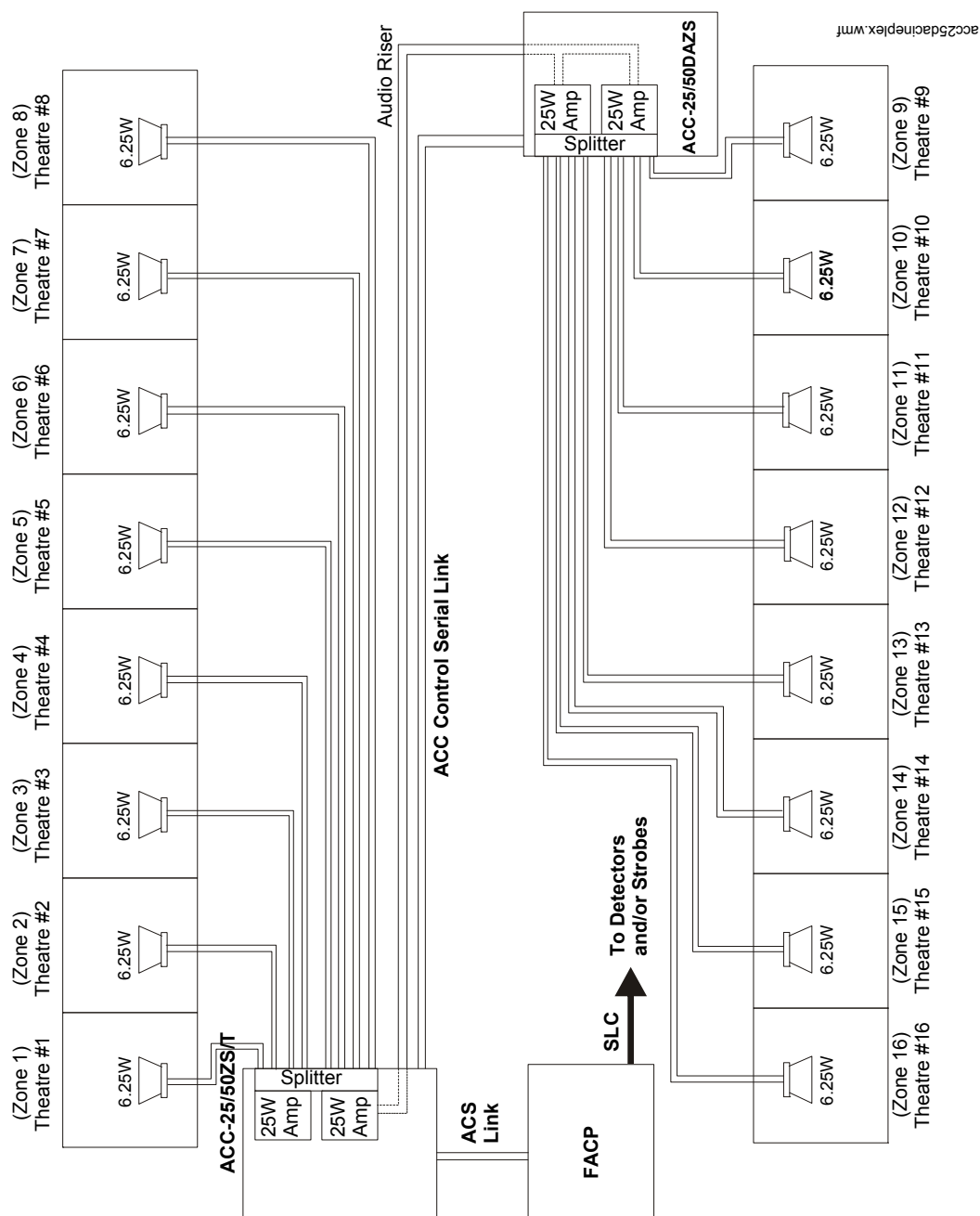

Figure 5.9 16 Theatre Cineplex

5.9 Audio Command Center 24 Zone System

In this application, the Fire Protection System consists of one ACC-25/50ZS/T panel with two ACC-25/50DAZS panels, 24 zones and an FACP. Automatic control by the FACP is provided through the ANN-BUS or ACS link to the ACC-25/50ZS/T. Manual control is possible via the keypad in the ACC-25/50ZS/T. Control of Audio Zones 9 - 24 is sent through the ACC Control Serial Link to the ACC-25/50DAZS Distributed Audio Panels. Alarm and Paging audio from the ACC-25/50ZS/T is delivered to Audio Zones 9 - 24 (ACC-25/50DAZS panels) by way of the Audio Riser.

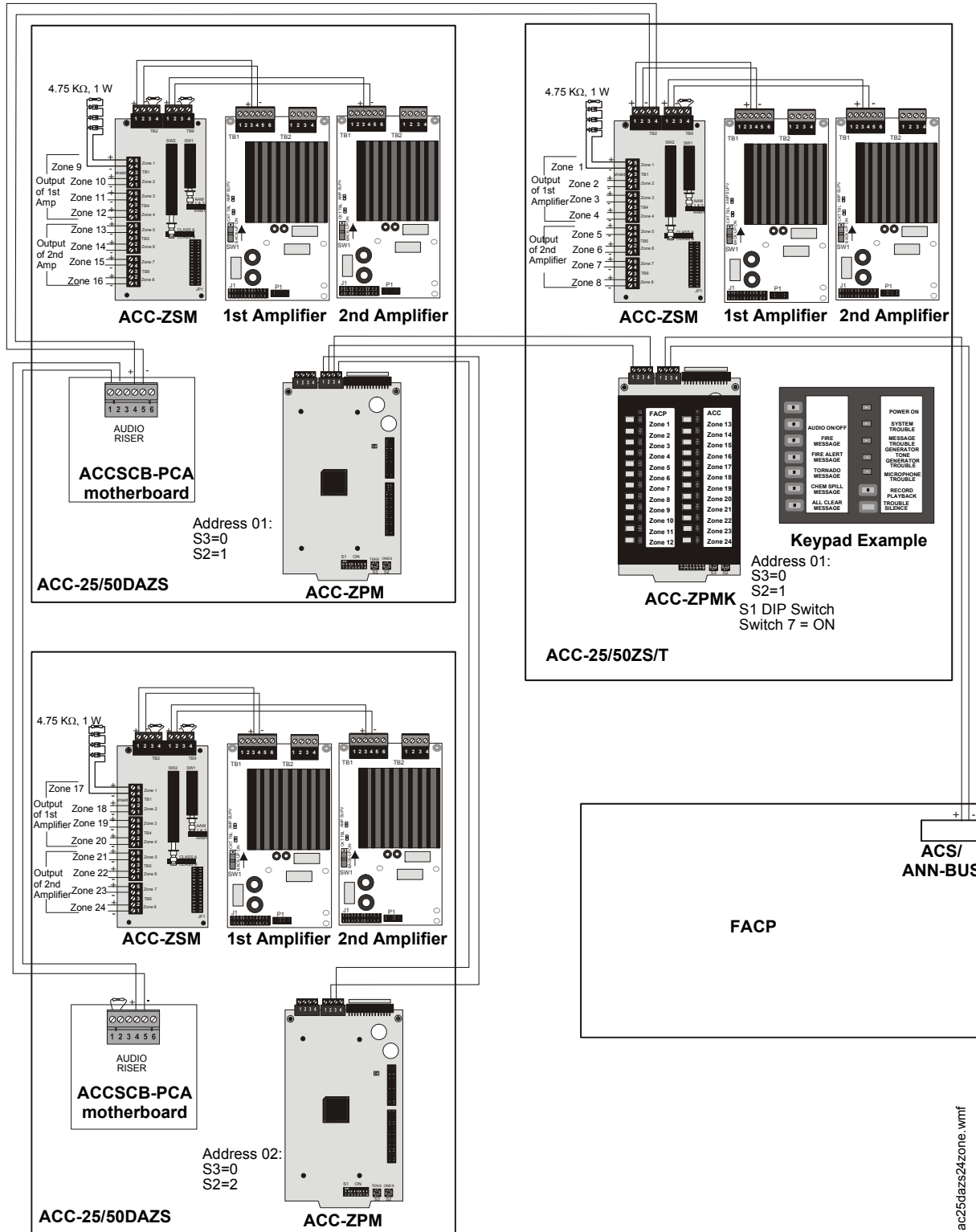

Figure 5.10 24 Zone System

acc25dazs24zone.wmf

Section 6: Power Supply Calculations

6.1 Overview

This section contains instructions and tables for calculating power supply currents in alarm and standby conditions. This is a four-step process, consisting of the following:

1. Calculating the total amount of AC branch circuit current required to operate the system
2. Calculating the power supply load current for non-fire and fire alarm conditions and calculating the secondary (battery) load
3. Calculating the size of batteries required to support the system if an AC power loss occurs
4. Selecting the proper batteries for your system

6.2 Calculating the AC Branch Circuit

The audio distribution panel requires connection to a separate, dedicated AC branch circuit, which must be labeled **FIRE ALARM**. This branch circuit must connect to the line side of the main power feed of the protected premises. No other non-fire alarm equipment may be powered from the fire alarm branch circuit. The branch circuit wire must run continuously, without any disconnect devices, from the power source to the transponder. Overcurrent protection for this circuit must comply with Article 760 of the National Electrical Codes as well as local codes. Use 14 AWG (2.00 mm²) wire with 600 volt insulation for this branch circuit.

The ACC-25/50DA & ACC-25/50DAZS require 1.57 amps from the AC branch circuit.

6.3 Calculating the System Current Draw

6.3.1 Overview

The secondary power source (batteries) must be able to power the system during a primary power loss. To calculate the non-fire alarm load on the secondary power source, use Calculation Column 1 in Table 6.2. The ACC-25/50DA must support a larger load current during a fire alarm condition and primary power loss. To calculate the fire alarm load on the secondary power source, use Calculation Column 2 in Table 6.2.

When calculating current draw and the battery size, note the following:

- ‘Primary’ indicates that the audio panel is being powered by AC.
- ‘Secondary’ indicates that the audio panel is being powered by battery backup during AC failure.
- All currents are given in amperes (A) and refer to the DC current being supplied by the panel. Table 6.1 shows how to convert milliamperes and microamperes to full amperes.

To convert....	Multiply	Example
Milliamperes (mA) to amperes (A)	mA x 0.001	3 mA x 0.001 = 0.003 A
Microamperes (µA) to amperes (A)	µA x 0.000001	300 µA x 0.000001 = 0.0003 A

Table 6.1 Converting to Full Amperes

6.3.2 How to use Table 6.2 to calculate system current draws

1. Enter the quantity of devices in both columns.
2. Enter the DC current draw where required. Refer to the *Device Compatibility Document* for compatible devices and their current draw.
3. Calculate the current draws for each in both columns.
4. Sum the total current for each column.
5. Copy the totals from Column 1 and Column 2 to Table 6.3 on page 74.

Following are the types of current that can be entered into Table 6.2:

- ✓ **Calculation Column 1** - The standby current load that the audio panel must support (from the batteries) during a non-fire alarm condition and a loss of AC power.
- ✓ **Calculation Column 2** - The alarm current draw that the audio panel must support (from the batteries) during a fire alarm condition and a loss of AC power

Table 6.2 contains two columns for calculating current draws. For each column, calculate the current and enter the total (in amps) in the bottom row. When finished, copy the totals from Calculation Column 1 and Calculation Column 2 to Table 6.3 on page 74.

Device Type	Calculation Column 1 Secondary, Non-Fire Alarm Current (amps)			Calculation Column 2 Secondary, Fire Alarm Current (amps)		
	Qty	X [current draw] =	total	Qty	X [current draw] =	total
ACC-25/50DA consisting of: Main Circuit Board and one ACC-AAM25 Audio Amplifier		X [0.285]			X [2.385]	
ACC-25/50DA consisting of Main Circuit Board, one ACC-AAM25 Audio Amplifier, one ACC-ZPM Zone Page Module and one ACC-ZSM Zone Splitter Module	1	X [0.440]	= []	1	X [2.505]	= []
ACC-AAM25 Audio Amplifier Module ¹	[] (1 max.)	X [0.065]=	[]	[]	X [2.00]=	[]
FC-RM Remote Microphone Module with ² FC-MIM Microphone Interface Module	[] (1 max.)	X [0.006]=	[]	[]	X [0.030]=	[]
ACC-ZPM Zone Page Module	[]	X[0.059]=	[]	[]	X[0.059]=	[]
ACC-ZSM Zone Splitter Module	[]	X[0.005]=	[]	[]	X[0.063]=	[]
Power Supervision Relays	[]	X []=	[]	[]	X []=	[]
Additional Current Draw from TB9 Special Application Auxiliary Power Output (0.035 amps maximum)	[]	X []=	[]	[]	X []=	[]
Sum each column for totals		Secondary non-alarm:		Secondary alarm:		

Table 6.2 System Current Draw Calculations

- 1 In backup configurations, the optional ACC-AAM25 draws no current in alarm.
- 2 Refer to the *Device Compatibility Document* for compatible devices and their current draws.
- 3 The FC-XRM70 Transformer Module draws no current in standby or alarm.
- 4 The FC-LPS Local Playback Speaker Module draws no current in standby or alarm.
- 5 The ACC-25/50DA will turn off the background music in the event AC power is lost in order to conserve battery power.

6.4 Calculating the Battery Size

Use Table 6.3 to calculate the total Standby and Alarm load in ampere hours (AH). This total load determines the battery size (in AH), required to support the ACC-25/50DA under the loss of AC power. Complete Table 6.3 as follows:

1. Enter the totals from Table 6.2 on page 73 Calculation Columns 1 and 2 where shown.
2. Enter the NFPA Standby and Alarm times (refer to Section 6.4.1, 'NFPA Battery Requirements').
3. Calculate the ampere hours for Standby and Alarm, then sum the Standby and Alarm ampere hours.
4. Multiply the sum by the derating factor of 1.2 to get the proper battery size (in AH).
5. Write the ampere hour requirements on the Protected Premises label located inside the cabinet door.

Secondary Standby Load (total from Table 6.2 Calculation Column 1) []	Required Standby Time (24 or 60 hours) []	=	AH
Secondary Alarm Load (total from Table 6.2 Calculation Column 2) []	Required Alarm Time (for 5 min., enter 0.084, for 10 min., enter 0.168, for 15 min., enter 0.250) []	=	AH
Sum of Standby and Alarm Ampere Hours		=	AH
Multiply by the Derating Factor		X 1.2	
Battery Size, Total Ampere Hours Required		=	AH

Table 6.3 Total Secondary Power Requirements at 24 VDC

6.4.1 NFPA Battery Requirements

NFPA requires 24 hours of standby plus 15 minutes activation for audio systems. The total ampere hours required cannot exceed 18 AH with an internal charger. An external charger can be used to increase the total ampere hours (internal charger must be disabled).

6.4.2 Selecting and Locating Batteries

Select batteries that meet or exceed the total ampere hours calculated in Table 6.3. The audio panel can charge batteries in the 7 AH to 18 AH range. The ACC-25/50DA Series can house up to 18 AH batteries.

Notes

Appendix A: Digital Voice Messages

The ACC-25/50DA FC-MGM module provides a 60 second record time which allows for a single fire message of 60 seconds length, two 30 second messages, three 20 second messages or four 15 second messages, which may be field programmed. Refer to Section 4.1.1, 'Record Push Button (on optional FC-MGM Module)' on page 52. The FC-MGM is provided with a factory recorded single 'primary' message which can be changed in the field. The prerecorded message (female voice) is:

“May I have your attention please. May I have your attention please. The signal you have just heard indicates a report of a fire in this building. Please proceed to the nearest exit and leave the building. Do not reenter the building unless directed to do so by the proper authorities.”

New messages can be recorded in the field. Be certain to get the approval of the Local Authority Having Jurisdiction prior to recording new messages. Following are some examples of messages which may be recorded in the field:

- “May I have your attention please. May I have your attention please. There has been a fire reported on your floor. There has been a fire reported on your floor. Please proceed to the stairways and exit the building. Do not use the elevators.”
- “May I have your attention please. May I have your attention please. There has been a fire alarm reported in the building. There has been a fire alarm reported in the building. Please proceed to the stairways and exit the building. Do not use the elevators, but proceed to the stairways and exit the building.”
- “May I have your attention please. May I have your attention please. A tornado warning has been issued for this area. A tornado warning has been issued for this area. Please take all appropriate safety actions at this time.”
- “May I have your attention please. May I have your attention please. A hurricane warning has been issued for this area. A hurricane warning has been issued for this area. Please take all appropriate safety actions at this time.”
- “May I have your attention please. May I have your attention please. An emergency condition exists on this floor. An emergency condition exists on this floor. Please proceed to the stairways and exit the building. Do not use the elevators.”
- “May I have your attention. This is an emergency. Please walk to the nearest exit and go to your assembly areas and await further instructions. This is an emergency.”
- “Your attention please. The fire alarm in this building has been activated. Please cease operations immediately and proceed into the nearest fire exit. Descend to street level and leave the building. Do not use the elevator.”
- “There has been a Fire Emergency reported in this building. Proceed calmly to fire stairs. Do not use elevators. Do not contact the front desk unless evacuation assistance is required. Proceed directly to fire stairs. Fire personnel will assist disabled and elderly from the fire stairs. Floor Wardens report status by fire phone.”
- “May I have your attention please. There has been a Fire Emergency reported in the building. While this is being verified, please leave the building by the nearest exit or exit stairway.”
- “Attention. Your attention please. The building emergency condition has been cleared. You may return to your normal activities. The building emergency has been cleared. You may return to your normal activities.”
- “Your attention please. A severe weather warning has been received. Please walk to the nearest safe area and wait for further instructions. Elevator lobbies, stairwells, bathrooms and auditoriums are designated safe areas in the event of severe weather. Stay away from windows and glass. Do not use the elevators.”

Appendix B: Addressable Module Connections

When configured with an addressable FACP such as the MS-9200UDLS, MS-9600(UD)LS, MS-9200UD, MS-9200C(E), or MS-9600, the ACC-25/50DA may be triggered either by an FACP main NAC output or from addressable control modules. Figure B.1 illustrates CMD1 triggered by an addressable control module. The addressable control module may trigger the ACC-25/50DA via reverse polarity (shown) or relay contact. The FACP monitors the ACC-25/50DA for faults while in the standby or alarm state by wiring a monitor module to the trouble contacts as shown in Figure B.1. Activation of the addressable control module is controlled by the FACP. Refer to the appropriate FACP manual for additional information.

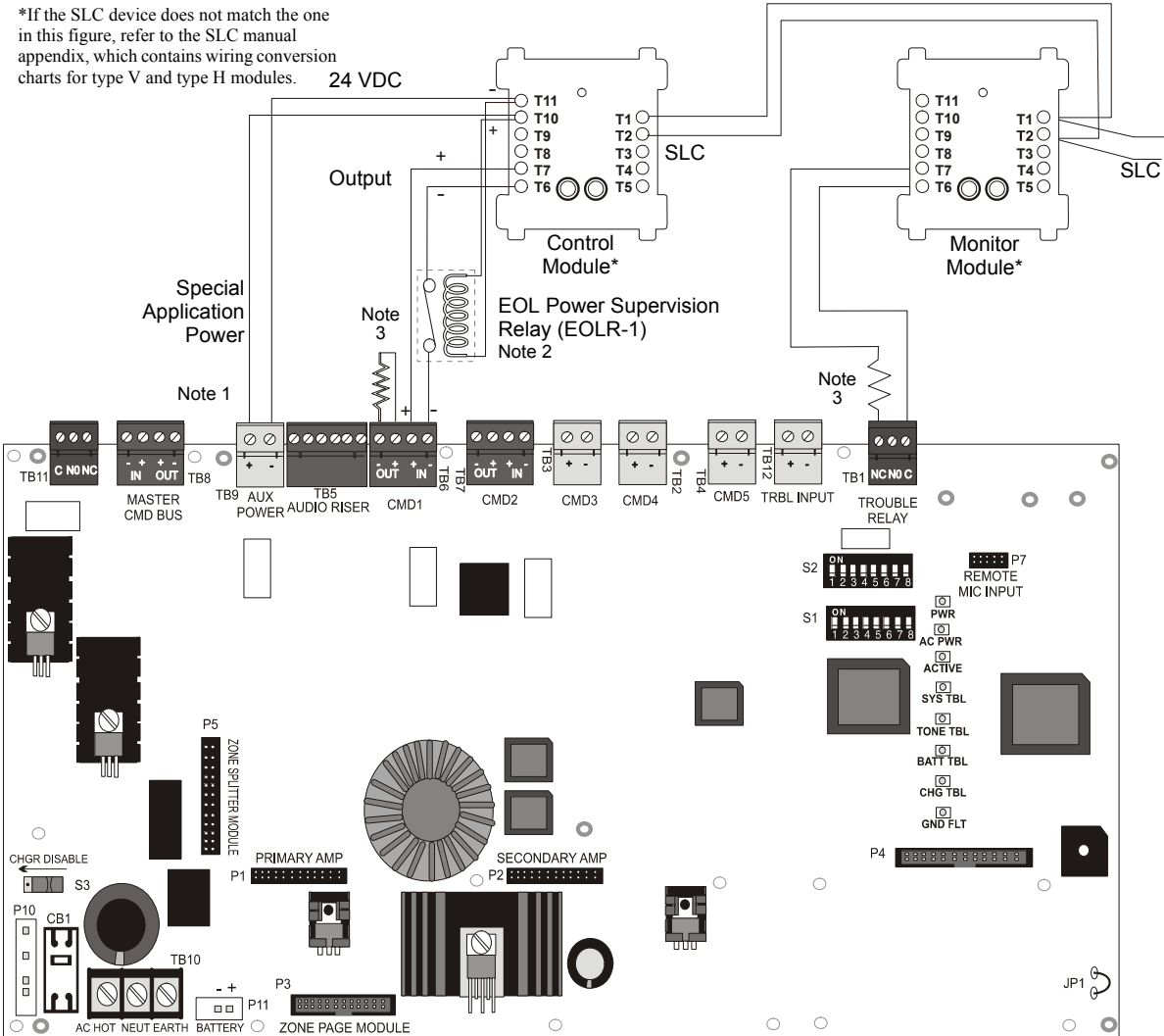

Figure B.1 Addressable Module Connections

Notes:

1. Auxiliary Power terminals for special application power only. Wiring must remain in the room.
2. Supervise the wiring between the ACC-25/50DA Series Auxiliary Power output and the control module with an EOL relay (EOLR-1)
3. End-of-Line resistor supplied with modules.

Appendix C: Wiring Requirements

Connecting external system accessories to the ACC-25/50DA main circuits must be carefully considered to ensure proper operation. It is important to use the correct type of wire, wire gauge and wire run length per each circuit. Refer to the following table to specify wire requirements and limitations.



NOTE: If an SLC loop is to be run in conduit with ACC-25/50DA Notification Appliance Circuits, the risk of encountering problems can be greatly reduced by using twisted, shielded cable on the SLC and NACs.

CIRCUIT CONNECTIONS		WIRE REQUIREMENTS		
Circuit Type	Circuit Function	Wire Type & Limitations	Recommended Maximum Distance (Feet)	Wire Gauge
AC Power TB3 (nonpower-limited)	Primary Power Input to Distributed Audio Panel, AC Voltage	See Note ¹	Power Supplied must be: 120 VAC, 60 HZ, 1.57 amps or 240 VAC, 50/60 Hz, 0.75 amps (see Note ¹)	Terminals Support 12-18 AWG (see Note ¹)
Audio Output ACC-AAM25 Module TB1 and ACC-ZSM Module (power-limited)	Notification Appliance Circuit	See Note ² Untwisted, unshielded or twisted, shielded	See Note ³	12 - 18 AWG
ACC-ZPM Module	ACS (EIA-485 Circuit)	See Note ² Twisted or twisted shielded	4,000 feet	12 - 18 AWG
CMD1 and CMD2 Main Board TB6 and TB7 (nonpower-limited)	Triggers Distributed Audio Panel	See Note ¹ Untwisted, unshielded or twisted, shielded	Depends on Output (trigger) Circuit 9 - 32 VDC, 1.6 mA for polarity reversal relay must be rated at 0.5 amp, 24 VDC	12 - 18 AWG
CMD3, CMD4 and CMD5 Main Board TB2, TB3 and TB4	Triggers Distributed Audio Panel	See Note ¹ Untwisted, unshielded or twisted, shielded	Depends on Output (trigger) Circuit from contact device	12 - 18 AWG
Main Board TB8 Master Command Bus Reverse Polarity (power-limited)	Input/Output Trigger for Multiple Distributed Audio Panel configurations	Untwisted, unshielded	200 ohms maximum	12 - 18 AWG
Trouble Relay Main Board TB1 (nonpower-limited)	Trouble Output	Maximum Current 2 amps	Depends on Input Circuit	12 - 18 AWG
AC Loss Relay Main Board TB11 (nonpower-limited)	AC Loss Output	Maximum Current 2 amps	Depends on Input Circuit	12 - 18 AWG

Table C.1 Distributed Audio Panel Wiring Requirements

- 1 Refer to NEC Standards.
- 2 Twisted, shielded wire is recommended for maximum protection against EMI and AFI emissions and susceptibility.
- 3 Must also meet NFPA 72 Standards for minimum and maximum sound levels.

Index

A

AC branch circuit
 calculation 72

AC Loss Relay 12, 14, 17, 21, 41
 Contact Rating 21, 41

AC Loss Response 56

AC Power 17
 see also Power On 54
 see also Primary Power 37
 wiring 37

ACC 67

ACC-25/50
 see also voice evacuation panel 11

ACC-25/50DA
 see also Audio•Command•Center•25/
 50DA 11

ACC-25/50ZS Modules 16

ACC-25/50ZS/T 16

ACC-AAM25 17, 22, 23
 Installation 46
 see also Audio Amplifier 11

ACC-ZPM 21
 installation 42
 programming 25, 28
 see also Zone Page Module 18

ACC-ZPM specification 18

ACC-ZPMK
 LEDs 57
 see also Zone Page Module 11

ACC-ZSM
 installation 44
 see also Zone Splitter Module 11, 18
 specification 18
 switch settings 30
 wiring 44

Addressable Module Connections 77

addressing 29

Amplifier Fault 57

Amplifier Supervision 20, 22
 LED 55

Application 12, 59

applications 62, 66

Audio Amplifier Module 17, 22, 23
 Installation 46
 Jumper 46, 47
 see also ACC-AAM25 11
 Switch S1 46

Audio Conversion Module 23
 Installation 47
 see also audio transformer module 12
 see also FC-XRM70 22

Audio Input 19, 20
 Input Current 19

 Input Impedance 19
 Input Voltage 19

audio input 31

Audio Input Jack 20

audio jack
 configuration 31, 52

Audio Power 12
 25 watts 12, 18
 50 watts 12

audio source 31

audio transformer module 11

AUDIO•COMMAND•CENTER•25/50DA
 see also ACC-25/50DA 11
 see also Distributed Audio Panel 11

Auxiliary Power 12
 Connection 39
 see also Specific Application Power 19,
 21, 39

B

Backbox Installation 33

Background Music 12, 25, 56

Backup
 Audio Amplifier 18, 23, 46
 Audio Amplifier Switch S1 18

Battery 17, 22
 Calculations 72
 Charger 21, 22
 Charger Capacity 17
 Charging Circuit 17
 Precaution 38
 see also Secondary Power 38

Battery Charger Switch
 see also S4 28

battery requirements
 NFPA 74

battery selection 74

battery size
 calculation 74

Battery Trouble LED 54

Battery Trouble Response 56

board layout 14

C

Cabinet 22
 Dimensions 34

calculating
 AC branch circuit 72
 battery size 74
 system current draw 72

Charger Trouble LED 54

Charger Trouble Response 56

- Chime Tone **12**
 - Circuit **20**
 - Nonpower-limited **45**
 - power-limited **45**
 - Circuit Trouble LED **20, 55**
 - Class A **22**
 - Class B **22**
 - CMD **40**
 - see also Command Input Circuit **12**
 - CMD Activation
 - Contact Closure **40**
 - NAC Polarity Reversal **40**
 - CMD1 **20, 40, 56**
 - see also Command Input Circuit **17**
 - CMD2 **20, 40, 56**
 - see also Command Input Circuit **17**
 - CMD3 **20, 40, 56**
 - see also Command Input Circuit **17**
 - CMD4 **20, 40, 56**
 - see also Command Input Circuit **17**
 - CMD5 **20, 40, 56**
 - see also Command Input Circuit **17**
 - Command Input Circuit **12, 17, 40**
 - Contact Closure Current **17**
 - End-of-Line Resistor 4.7K **17**
 - Operating Voltage **17**
 - Reverse Polarity Current **17**
 - see also CMD **11, 20**
 - components, standard **11**
 - Contact Rating
 - AC Loss Relay **17**
 - System Trouble Relay **19**
 - Contact-closure **17**
 - Control
 - see also Push-button **52**
- D**
- DIP Switches
 - S1 **25, 26**
 - S2 **25**
 - S5 **28**
 - Distributed Audio Panel **20**
 - Backbox **35**
- E**
- Earth Ground Connection **37**
 - EIA-485
 - addressing **29**
 - End-of-Line Resistor
 - Audio Amplifier 4.75K **18**
 - Command Input Circuit 4.7K **17**
- F**
- FC-LPS
 - see also Local Playback Speaker **21, 23**
 - see also Local Playback Speaker Module **49**
 - FC-MGM **31, 32**
 - DIP switch setting **31**
 - installation **48**
 - see also Message Generator Module **48**
 - FC-MIM **23**
 - see also Microphone Interface Module **13, 19, 21**
 - FC-RM **23**
 - see also Remote Microphone **13, 19, 21**
 - FC-XRM70 **22, 23**
 - Installation **46, 47**
 - see also Audio Conversion Module **22**
 - see also Transformer Module **47**
 - Fire Alarm Control Panel
 - see also FACP **11**
 - Fire Alarm Operation **55**
 - Fire Alarm Restoral **55**
 - Form-C **14**
 - see also Relay **41**
 - see Relay **19, 21**
- G**
- Ground Fault LED **54**
 - Ground Fault Response **56**
- H**
- Hi-Lo Tone **12**
- I**
- Indicator
 - see also LED **20, 52**
 - Input Circuit **20, 39**
 - Installation
 - Transformer **36**
- J**
- Jumper
 - Audio Amplifier **18**
- K**
- Knockout Locations
 - Cabinet **34**
- L**
- LED **20, 22, 46**
 - AC Power **54**
 - Amplifier Supervision **20, 55**
 - Battery Trouble **54**
 - Charger Trouble **54**
 - Circuit Trouble **20, 55**
 - Ground Fault **54**

- Power On **20**
- Remote Microphone Trouble **54**
- System Trouble **20**
- Tone Generator Trouble **20**
- Local Playback Speaker **13, 21, 23**
- Local Playback Speaker Module **49**

M

- Main Circuit Board **21**
- Master CMD Out **18**
 - current **18**
 - Operating Voltage **18**
 - Short Circuit Current **18**
- Master Command Bus **39**
 - End-of-Line Resistor **39**
- Master Command Bus Output **21**
 - current **21**
 - voltage **21**
- message
 - playback **53**
 - primary and backup **48**
 - recording **52**
 - repeat **54**
- Message Generator Module **48**
- Message Generator Trouble Response **56**
- message playback **53**
- message review **49**
- message storage
 - enable **52**
- Messages
 - Sample **76**
- Microphone Interface Module **19, 23**
 - see also FC-MIM **13, 21**
- Modules
 - Optional **46**
- Mounting
 - surface **33**
- Mounting Cabinet
 - Surface Mount **33**
- Mounting Panel **33**

N

- NAC **11, 40, 42, 58**
 - Operation **57**
 - see also Notification Appliance Circuit **11, 21**
 - Style Y **12, 21**
 - Style Z **12, 21**
- Nonpower-limited Circuit **45**
- Notification Appliance Circuit **11, 12, 20, 40, 42**
 - see also NAC **21**

O

- Operation **55**
- Option Modules **23, 46**

- Output Circuit **21**

P

- paging **39**
- PC Jack **20**
- Power **12, 19, 37, 57**
 - see also AC power **17**
 - see also Specific Application Power **21**
- Power On LED **20**
- Power Supply **22**
 - calculations **72**
- Power-limited Circuit **17, 18, 22, 45**
- Primary Power
 - see also AC power **37**
- Product Description **11**
- Product Features **12**
- Programming **17, 20, 25, 40**
 - ACC-ZPM **25**
 - DIP Switches **25**
 - S1 DIP Switch **26**
 - S5 DIP Switch **28**

R

- RCA Jack **19**
 - see also Audio Input **19**
- record
 - enable **52**
 - input source **52**
- record bypass switch **32, 52**
- record enable
 - digital voice message **31**
- record message **52**
 - instructions **52**
- Relay **12, 21**
 - AC Loss **17**
 - AC Power Loss **41**
 - AC power loss **12**
 - system trouble **12**
 - Trouble **19, 41**
- Remote Microphone **23**
 - Operation **57**
 - see also FC-RM **13, 19, 21**
- Remote Microphone Trouble LED **54**
- resistance
 - maximum between panels **39**
- resistor
 - End-of-Line **39**

S

- S1
 - DIP Switch Settings **26**
- S4
 - see also Battery Charger Switch **28**
- Secondary Power
 - see also Battery **38**

Selecting **74**
 single speaker circuit with backup **62**
 Slow-Whoop Tone **12**
 Speaker Circuit **12, 18, 42**
 End-of-Line Resistor 4.75K **18**
 Operating Voltage **18**
 see also NAC **12**
 Style Y **18**
 Style Z **18**
 special application power **12**
 Specific Application Power **19, 39**
 see also Auxiliary Power **21, 39**
 Specifications **17**
 split amplifier **30**
 Steady Tone **12**
 Style Y **22**
 Style Z **22**
 Supervision **11, 18, 22**
 Surface Mount **33**
 SW1 DIP switch settings **31**
 SW2
 Record Bypass Switch **32**
 Switch
 Functions **52**
 S1 Audio Amplifier **18**
 switch
 FC-MGM configuration **48**
 system current draw
 calculation **72, 73**
 system status **55**
 System Trouble LED **20**

T

Tone **12**
 Generator **12**
 Tone Generator Fault Response **56**
 Tone Generator Trouble LED **20**
 tone transmission **31**
 Transformer **14**
 Transformer Conversion Module
 Installation **46**
 Transformer Installation **36**
 Transformer Module
 70.7 volt Conversion **47**
 see also FC-XRM70 **47**
 Trouble Relay **12, 14, 19, 21, 41**
 Contact Rating **19, 21, 41**
 Trouble Response **56**
 Trouble Restoral **57**

U

UL Power-limited Wiring **45**

V

voice evacuation panel

 see also ACC-25/50DA **11**
 voice message
 repeat **32**

W

Wiring Requirements **78**

Z

Zone Page Module **18, 21**
 installation **42**
 programming **28**
 see also ACC-ZPM **11**
 Zone Splitter Module **18**
 see also ACC-ZSM **11**
 switch settings **30**
 wiring **44**

Manufacturer Warranties and Limitation of Liability

Manufacturer Warranties. Subject to the limitations set forth herein, Manufacturer warrants that the Products manufactured by it in its Northford, Connecticut facility and sold by it to its authorized Distributors shall be free, under normal use and service, from defects in material and workmanship for a period of thirty six months (36) months from the date of manufacture (effective Jan. 1, 2009). The Products manufactured and sold by Manufacturer are date stamped at the time of production. Manufacturer does not warrant Products that are not manufactured by it in its Northford, Connecticut facility but assigns to its Distributor, to the extent possible, any warranty offered by the manufacturer of such product. This warranty shall be void if a Product is altered, serviced or repaired by anyone other than Manufacturer or its authorized Distributors. This warranty shall also be void if there is a failure to maintain the Products and the systems in which they operate in proper working conditions.

MANUFACTURER MAKES NO FURTHER WARRANTIES, AND DISCLAIMS ANY AND ALL OTHER WARRANTIES, EITHER EXPRESSED OR IMPLIED, WITH RESPECT TO THE PRODUCTS, TRADEMARKS, PROGRAMS AND SERVICES RENDERED BY MANUFACTURER INCLUDING WITHOUT LIMITATION, INFRINGEMENT, TITLE, MERCHANTABILITY, OR FITNESS FOR ANY PARTICULAR PURPOSE. MANUFACTURER SHALL NOT BE LIABLE FOR ANY PERSONAL INJURY OR DEATH WHICH MAY ARISE IN THE COURSE OF, OR AS A RESULT OF, PERSONAL, COMMERCIAL OR INDUSTRIAL USES OF ITS PRODUCTS.

This document constitutes the only warranty made by Manufacturer with respect to its products and replaces all previous warranties and is the only warranty made by Manufacturer. No increase or alteration, written or verbal, of the obligation of this warranty is authorized. Manufacturer does not represent that its products will prevent any loss by fire or otherwise.

Warranty Claims. Manufacturer shall replace or repair, at Manufacturer's discretion, each part returned by its authorized Distributor and acknowledged by Manufacturer to be defective, provided that such part shall have been returned to Manufacturer with all charges prepaid and the authorized Distributor has completed Manufacturer's Return Material Authorization form. The replacement part shall come from Manufacturer's stock and may be new or refurbished. THE FOREGOING IS DISTRIBUTOR'S SOLE AND EXCLUSIVE REMEDY IN THE EVENT OF A WARRANTY CLAIM.

Warn-HL-08-2009.fm



World Headquarters
1 Firelite Place
Northford, CT 06472-1653 USA
203-484-7161
fax 203-484-7118

www.firelite.com

ISO 9001
CERTIFIED
ENGINEERING & MANUFACTURING
QUALITY SYSTEMS