



ECLIPSE-32 MATRIX

INSTRUCTION MANUAL

Eclipse-32 Matrix Instruction Manual
© 2007, 2009 Vitec Group Communications Ltd. All rights reserved.

Part Number 810315Z Rev. 7

Vitec Group Communications LLC
850 Marina Village Parkway
Alameda, CA 94501
U.S.A.

Vitec Group Communications Ltd
7400 Beach Drive
Cambridge Research Park
Cambridshire
United Kingdom
CB25 9TP

The Vitec Group plc
Beijing Representative Office
Room 706, Tower B
Derun Building, YongAn Dongli A No.3
Jianwai Ave., Chaoyang District
Beijing, P.R.China 100022

® Clear-Com, CellCom/FreeSpeak and the Clear-Com Communication Systems logo are registered trademarks of The Vitec Group plc.

Website: www.clearcom.com

CONTENTS

INTRODUCTION	1-1
The Eclipse-32 Matrix	1-1
Intelligent Linking	1-2
High Speed Link	1-2
IFB Support	1-3
Powerful Programming Features	1-3
Individual Level Control	1-4
Excellent Audio Quality	1-4
Robust and Compatible	1-4
Eclipse-32 Applications	1-5
System Basics	1-5
Matrix Hardware	1-5
Power Supplies	1-5
Rear-Panel Connectors (“Ports”)	1-6
Eclipse Configuration Software (ECS)	1-6
Remote Intercom Panels and Accessory Panels	1-6
Remote Interfaces	1-7
OPERATING AN ECLIPSE-32 MATRIX	2-1
Storing and Retrieving Configurations	2-1
Front-Panel Controls and Lights	2-1
PC Connector	2-2
Reset Button	2-2
OK Light	2-2
Configuration “Config” Button	2-2
Configuration Status Lights	2-2
Power Supply Alarm Lights (1 and 2)	2-3
LAN Status Lights	2-3
Port Status Lights	2-3
Default IP Address	2-3
Connecting the Matrix to Remote Devices	2-4
Connecting to AC Power	2-5
Connecting to Panels and Interfaces	2-5
Connecting to General-Purpose Outputs	2-5
Connecting to General-Purpose Inputs	2-6
Connecting to a GPI/RLY Interface	2-6
Linking to a Second Eclipse-32 Matrix	2-7

Connecting to a Local Area Network	2-7
INSTALLING AN ECLIPSE-32 MATRIX	3-1
Verifying the Shipment	3-1
Unpacking the System	3-1
Installing the Eclipse-32 Matrix	3-1
Battery Backup	3-2
Wiring the Matrix to Remote Devices	3-2
Wiring to AC Mains Power	3-3
Wiring to Panels and Interfaces	3-3
4-Pair Analog	3-3
Wiring to 4-Wire Equipment	3-4
2-Pair Analog	3-4
Single-Pair Digital	3-6
Wiring General-Purpose Outputs	3-6
Wiring General-Purpose Inputs	3-7
Non-Isolated Mode	3-8
Opto-Isolated Mode	3-8
Pin Assignments for General-Purpose Inputs Connector	3-10
Wiring to a GPI/RLY Interface	3-10
RLY-6 Interface Wiring	3-11
GPI-6 Interface Wiring	3-13
Wiring to a Second Eclipse Matrix	3-15
Wiring to a Local Area Network	3-17
Wiring to a Computer	3-18
MAINTENANCE	4-1
Recommended Spare Parts	4-1
Dual, Independent Power Supplies	4-1
SPECIFICATIONS	5-1
GLOSSARY	6-1
Eclipse Manuals	6-5
Software Manuals	6-5
Hardware Manuals	6-5
LIMITED WARRANTY	W-I
TECHNICAL SUPPORT & REPAIR POLICY	W-V
TECHNICAL SUPPORT POLICY	W-v

RETURN MATERIAL AUTHORIZATION POLICYW-vi
REPAIR POLICY W-viii

IMPORTANT SAFETY INSTRUCTIONS

Please read and follow these instructions before operating this product.



1. Read these instructions.
2. Keep these instructions.
3. Heed all warnings.
4. Follow all instructions.
5. Do not use this apparatus near water.
6. Clean only with dry cloth.
7. Do not block any ventilation openings. Install in accordance with the manufacturer's instructions.
8. Do not install near any heat sources such as radiators, heat registers, stoves, or other apparatus (including amplifiers) that produce heat.
9. Do not defeat the safety purpose of the polarized or grounding-type plug. A polarized plug has two blades, with one wider than the other. A grounding-type plug has two blades and a third grounding prong. The wide blade or the third prong are provided for your safety. If the provided plug does not fit into your outlet, consult an electrician for replacement of the obsolete outlet.
10. Protect the power cord from being walked on or pinched particularly at plugs, convenience receptacles, and the point where they exit from the apparatus.
11. Only use attachments/accessories specified by the manufacturer.
12. Use only with the cart, stand, tripod, bracket, or table specified by the manufacturer, or sold with the apparatus. When a cart is used, use caution when moving the cart/apparatus combination to avoid injury from tip-over.
13. Unplug this apparatus during lightning storms or when unused for long periods of time.
14. Refer all servicing to qualified service personnel. Servicing is required when the apparatus has been damaged in any way, such as power-supply cord or plug is damaged, liquid has been spilled or objects have fallen into the apparatus, the apparatus has been exposed to rain or moisture, does not operate normally, or has been dropped.
15. **WARNING:** To reduce the risk of fire or electric shock, do not expose this product to rain or moisture.

Please familiarize yourself with the safety symbols in Figure 1. When you see these symbols on this product, they warn you of the potential danger of electric shock if the main station is used improperly. They also refer you to important operating and maintenance instructions in the manual.

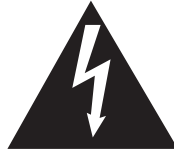

This symbol alerts you to the presence of uninsulated dangerous voltage within the product's enclosure that might be of sufficient magnitude to constitute a risk of electric shock. Do not open the product's case.



This symbol informs you that important operating and maintenance instructions are included in the literature accompanying this product.

Figure 2-1: Safety Symbols

EMC AND SAFETY

The Eclipse-32 matrix meets all relevant CE, FCC, UL, and CSA specifications set out below:

EN55103-1 Electromagnetic compatibility. Product family standard for audio, video, audio-visual, and entertainment lighting control apparatus for professional use. Part 1: Emissions.

EN55103-2 Electromagnetic compatibility. Product family standard for audio, video, audio-visual, and entertainment lighting control apparatus for professional use. Part 2: Immunity.

UL 60065-7, CAN/CSA-C22.2 No.60065-3, IEC 60065-7 Safety requirements.

And thereby compliance with the requirement of Electromagnetic Compatibility Directive 2004/108/EC and Low Voltage Directive 2006/95/EC

This device complies with Part 15 of the FCC Rules. Operation is subject to the following two conditions: (1) this device may not cause harmful interference, and (2) this device must accept any interference received, including interference that may cause undesired operation.



INTRODUCTION

THE ECLIPSE-32 MATRIX

The Eclipse family of communications products includes the Eclipse-32 digital matrix intercom, which offers 32 full-duplex communication ports, plus four extra 4-wire ports, in a one rack unit (1 RU) chassis. The Eclipse-32 matrix supports the same V-Series panels, i-stations, 4000 series panels, ICS digital matrix panels and interfaces as its larger counterparts, the Eclipse Omega and Median matrices, and is programmed and controlled with the same Eclipse Configuration System (ECS) software.

Two Eclipse-32 matrices can be joined together to form an intelligently linked non-blocking 64-port system in two rack units (2 RU) using a single RJ-45 “base loop” connection. The Eclipse-32 matrix also provides two power supplies for fail-safe redundancy, and onboard general-purpose inputs and outputs.

The Eclipse-32 matrix is built around the powerful Motorola 8260 processor, giving it the same processing power as the larger Eclipse Omega and Median matrices.

This manual refers to facilities in the Eclipse 4.2 software release.

The Eclipse-32 digital matrix intercom features 32 full-duplex communications ports, plus four 4-wire ports. The matrix fits in one rack unit (1 RU) of a standard Electronic Industry Association equipment rack.

Features of the Eclipse-32 matrix include:

- Thirty-six ports in one rack unit (1 RU), including four 4-wire ports.
- Eight onboard relays and eight onboard GPIs.
- Non-blocking 64-port system created by connecting two matrices with the high-speed link.
- Intelligent linking of up to 15 matrices using the 4-wire trunks and a LAN.
- Two power supplies for fail-safe redundancy.
- Seamless interfacing.
- DTMF inward access.
- Programmable VOX.
- Individual level control.
- Intuitive ECS programming software.
- Remote matrix access via Internet/Ethernet.
- Frequency response of 30 Hz to 22 kHz, ± 3 dB.
- SNR and crosstalk > -70 dB.

INTELLIGENT LINKING

An intelligent link may be used to connect an Eclipse-32 to other Eclipse-32, Eclipse Pico, Eclipse Median or Eclipse Omega matrices. Up to 15 matrices may be connected. The linking between matrices is via dedicated trunk lines between ports on the linked systems.

This capability is in addition to the high-speed link which connects two Eclipse-32 matrices into one non-blocking 64-port system subject to the condition described below.

Two Eclipse-32 matrices that are connected using a high-speed link cannot also be connected together with a trunk line. In this case trunk lines should only be used to connect such Eclipse-32 systems to other matrices.

Any port within the matrix may be used as a trunk line, and carries one full-duplex communications path between the matrices. Typically the number of trunk lines would equal the anticipated simultaneous communications between matrices. The system will intelligently use and release these lines to route the communications traffic between panels connected with the various matrices, routing the calls through available open trunks.

HIGH SPEED LINK

A high speed link is used to connect two Eclipse-32 matrices together via the Base Loop Connector to create a 64-port non-blocking system. The high speed link operates by 'mapping' the physical ports (0-35) of the remote system onto a second set of virtual ports on the local system (36-71). A panel on the local system can listen to a panel on the remote system simply by listening to the virtual port for that panel.

If a panel on the remote system opens a talk path to a panel on the local system a message is sent via the link instructing the local system to create the required audio path from the remote system to the local panel.

The ethernet link is required to pass key labels between the systems as well as receive configuration data from ECS.

A diagram of High Speed Link operation is shown in Figure 1-1.

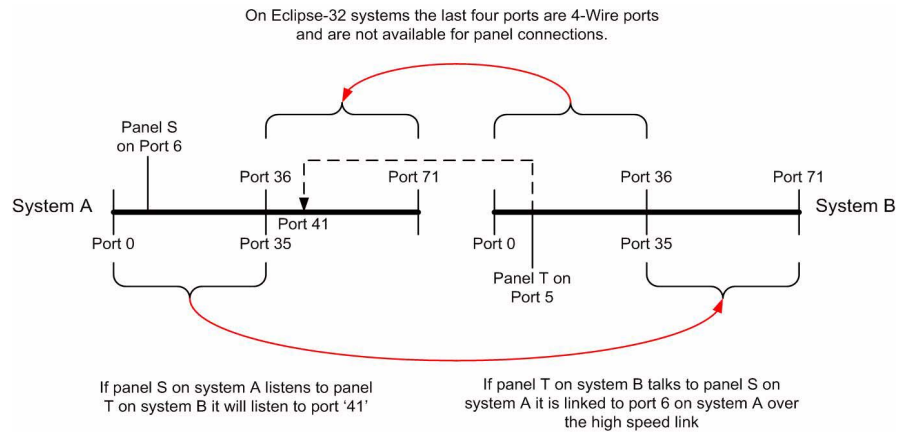

Figure 1-1: High Speed Link Operation

IFB Support

The High Speed Link supports the use of remote callers to IFB destinations between the linked systems. When a remote caller opens an audio path to an IFB destination the source for that IFB will be dimmed as normal.

The High Speed Link will support the use of Local IFB where Assignment Panels can assign sources to an IFB locally. This option may be enabled in ECS (Advanced Settings > AP Panel Options > IFB Assignment).

POWERFUL PROGRAMMING FEATURES

The Eclipse Configuration System is a powerful programming software suite that covers all aspects of the Eclipse-32, Eclipse Pico, Eclipse Median and Eclipse Omega digital intercom matrices. From creating user labels for panel key assignments, to configuring interfaces, assigning routes, and adjusting system levels, the intuitive software makes the process transparent and relatively simple to control.

A series of pull-down menus eases navigation through the software. Visual representations of intercom panels allow drag-and-drop placement of labels onto the panel keys.

Software features include:

- Global and local IFBs
- Programmable VOX
- DTMF inward access
- Activation of relays, routes, and DTMF sequences via controls
- Global and individual key latch disable
- Configuration of matrix and panel relays

- Forced listens (normally made routes)
- Port I/O level control
- Local and global ISO routes
- Control labels

The Eclipse-32 matrix allows TCP/IP access to the system for updates. The system may be accessed remotely for programming or to retrieve configurations. Up to four full-system configurations may be stored in the Eclipse-32 matrix, and an unlimited number of configurations may be backed up on a computer and downloaded to the matrix as needed.

INDIVIDUAL LEVEL CONTROL

Both incoming and outgoing volume levels can be adjusted for each device connected to an Eclipse-32 port, which allows the Eclipse-32 to be connected to a wide variety of panels and communications devices either directly via the port or via interfaces. On the panels, individual listen-level controls allow the operator to adjust the level of each key to provide a customized audio “mix”.

EXCELLENT AUDIO QUALITY

The Eclipse-32 matrix features industry-leading 24-bit, 48 kHz audio sampling, yielding a frequency response of 30 Hz to 22 kHz, ± 3 dB. With a signal-to-noise ratio better than -70 dB, and crosstalk better than -70 dB, the audio among panels, interfaces, and other system inputs and outputs is clean and distinct. Level adjustments are in 0.355 dB steps, which will sound completely smooth to the user.

ROBUST AND COMPATIBLE

The Eclipse-32 matrix houses two independent power supplies. These may be connected to a main and backup power source for redundancy. In the unlikely event of the failure of one of these power supplies, the second supply will automatically take over. The Eclipse-32 is robust even in the face of a major power outage. In the event of a complete power interruption the system will return with all previously set talk and listen paths in place when power is restored.

The Eclipse-32 matrix is fully compatible with Clear-Com’s modular matrix interface modules and frames. It can transparently interface with telephones, two-way radios, camera and 2-wire intercoms, 4-wire devices, and audio sources. Eclipse-32 is also compatible with most of the matrix intercom panels, including the V-Series, ICS-92, ICS-2003, 4000 series, and i-stations.

ECLIPSE-32 APPLICATIONS

The Eclipse-32 is the perfect solution for high-quality full-duplex communications requiring a moderate number of ports in a compact 1-RU form. With the ability to expand to 64 ports in 2 RU, tasks such as mobile production, small to mid-sized studio integration, and sports and performing facilities communications are easily realized. Intelligent linking to other Eclipse 32 and Eclipse Omega matrices adds to its ability to be the core of a comprehensive communications system.

SYSTEM BASICS

A complete Eclipse-32 system consists of a central matrix and the remote audio devices—intercom panels, interfaces, 4-wire equipment—connected to it. Each element of the Eclipse-32 system is briefly described in this chapter and more fully described later in this manual and in the Eclipse set of manuals.

The Eclipse set of manuals includes the overview manual *Eclipse Matrix Installation Manual* (part 810298Z), as well as individual manuals for each matrix, panel, and interface in the system.

MATRIX HARDWARE

The Eclipse-32 matrix is 19 inches wide and one rack unit high (26.9 cm x 48.3 cm). It installs in a standard Electronics Industry Association equipment rack. No parts of the unit are removable without it being taken out of service.

The matrix's front panel provides pushbuttons and indicator lights for operating the system, while the back panel holds the RJ-45 connectors, or "ports," for connecting remote intercom panels and interfaces to the system. The next chapter describes the matrix's operation in more detail.

Note: The term "central matrix" is used to differentiate the system's core hardware and software from the connected intercom panels and interfaces. The central matrix itself consists of the matrix hardware and configuration software.

POWER SUPPLIES

An Eclipse-32 matrix has two internal power supply units. One power supply unit can power the entire matrix; the second unit provides a backup in case of failure or damage to the first unit.

In addition, the two supplies have separate IEC connectors to AC mains, and are designed for completely automatic and transparent changeover between supplies in the event of a power outage in one of the AC mains circuits.

A power-supply failure sensor is connected to a warning light, allowing power anomalies to be diagnosed.

REAR-PANEL CONNECTORS (“PORTS”)

The Eclipse-32 matrix connects to remote devices such as intercom panels, interfaces, general purpose inputs and outputs, local area networks, and other matrices through its rear-panel hardware connectors.

A rear-panel RJ-45 connector to which cable is connect to run from the matrix to a panel or interface is called a “port”. Shielded category-5 cable is connected to a “port” to carry signals from the Eclipse-32 matrix to connected remote intercom panels or interfaces. Later chapters of this manual discuss these connections in detail.

ECLIPSE CONFIGURATION SOFTWARE (ECS)

The Eclipse Configuration System (ECS) software controls the operation of the matrix by sending electronic signals to the Eclipse-32 matrix, which then relays the signals to the remotely connected panels and interfaces.

“Configuration Maps”—which are the operating parameters of complete system setups can be created on the ECS computer. The Eclipse Configuration System programming software stores the created configurations on the computer’s hard disk using a relational database which holds up to two gigabytes of configuration data and is able to store over 100,000 complex system configurations. ECS can then upload four complete configurations from the computer to the Eclipse-32 matrix’s operational memory to retrieve and activate directly from the matrix when needed.

The Eclipse Configuration System software runs on the following versions of Windows: Windows 2000, Windows XP, Windows Server 2003 and Windows Vista (with restrictions). When running ECS on Windows operating systems, the client and server can run on separate machines connected over a network.

The Eclipse Configuration System can be used to create point-to-point and fixed group or party-line communications among the connected remote audio devices, assign a “label” to each port/panel, and inhibit or enable features at any connected remote panel. The Eclipse Configuration System can be set up to run on a client/server model over a network allowing the matrix to be controlled remotely.

REMOTE INTERCOM PANELS AND ACCESSORY PANELS

All analog intercom panels connect to the central matrix via shielded category-5 cable terminated with RJ-45 connectors. Digital panels connect to the central matrix through AES-6 or DIG-2 digital module interfaces. Digital panels require double-shielded 24 AWG conductor category-6 enhanced (CAT-6E) cable to connect to a DIG-2 interface or coaxial cable to connect to the AES-6-CX rear card. For further

details on connecting digital panels to the Eclipse-32 please refer to the appropriate product manual.

The following intercom panels are compatible with the Eclipse-32 matrix system:

- V-Series panels, including expansion panels
- i-Station family, including expansion panels
- ICS-2003 intercom panel, including expansion panels
- ICS-52 and ICS-92 intercom panels, including expansion panels
- ICS-62 and ICS-102 intercom panels, including expansion panels
- ICS-1008 and ICS-1016 intercom panels, including expansion panels

Each of these panels is described in its own manual. For a full description of the operation, installation and maintenance of a panel, please refer to the appropriate panel manual.

REMOTE INTERFACES

Interface modules convert the 4-wire signals of a central matrix port to other types of signals that communicate with devices such as telephones, camera intercoms, two-way radios, and so on. In this way non-4-wire devices can communicate with the central matrix.

Each interface module has hardware connectors to connect to both the central matrix and to the external device that communicates with the central matrix. Most interface modules connect to the central matrix via shielded category-5 cable terminated with RJ-45 connectors. The DIG-2 digital interface module, however, connects to the central matrix via double-shielded 24 AWG conductor category-6 enhanced (CAT-6E) STP cable.

The type of cable used to connect the interface module to the non-4-wire device varies with the device. Each of these connections is described more fully in the individual manual for each interface.

The following interface modules are compatible with the Eclipse-32 matrix:

- TEL-14 telephone interface module
- CCI-22 dual party-line interface module.
- FOR-22 four-wire interface module.
- GPI-6 general purpose inputs interface module.
- RLY-6 relay (general-purpose outputs) interface module.
- DIG-2 digital interface module.
- AES-6 digital interface module.

Each of these interfaces is described in its own manual. For a full description of the operation, installation, and maintenance of an interface, please refer to the individual manual for that interface.

2

OPERATING AN ECLIPSE-32 MATRIX

STORING AND RETRIEVING CONFIGURATIONS

No parts of the Eclipse -32 matrix are removable without taking the unit out of service.

A “configuration map” is a complete set of operating parameters for the matrix system which includes talk and listen paths for each connected intercom panel. Depending upon the remote interfaces installed, the configuration map can also include more sophisticated features such as paging, call signaling, interrupt foldback (IFB), ISO, groups, automatic DTMF dialing, routing, and many other features.

The system manager creates a configuration in the Eclipse Configuration System programming software and then uploads the configuration to the Eclipse-32 matrix’s operational memory through the software. The Eclipse-32 matrix’s operational memory holds up to four complete configurations. From the controls on the matrix’s front panel the system manager may select which configuration to apply at any given time.

In the event of a power failure, the Eclipse-32 system can automatically restore itself to full functioning by retrieving configuration information from its non-volatile operational memory.

FRONT-PANEL CONTROLS AND LIGHTS

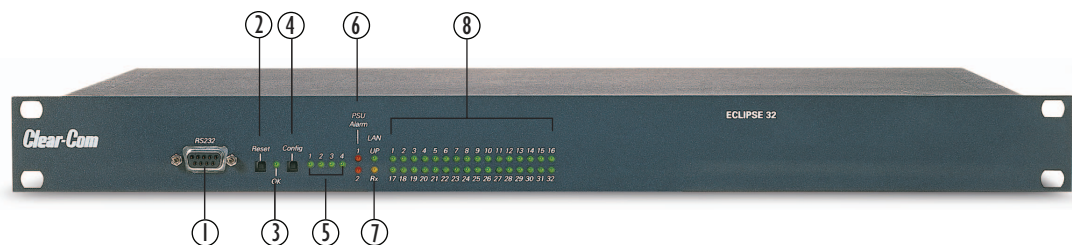

- 1 PC connector for computer
- 2 Reset button
- 3 OK light
- 4 Configuration ("config") button to select among onboard configurations

- 5 Configuration status lights to indicate currently active configuration
- 6 Power supply alarm lights (1 and 2)
- 7 LAN status lights
- 8 Port status lights

Figure 2-1: Front Panel of Eclipse-32 Matrix

① PC CONNECTOR

The female 9-pin D-type socket labeled “PC” connects the matrix to an external computer.

② RESET BUTTON

Pressing the reset button causes the matrix to stop its current activity and to restart. The same configuration that was active before the matrix was reset will be active after it is reset.

During the reset, configuration information reloads to the matrix’s operational memory from its non-volatile memory and the matrix starts running again from the beginning.

③ OK LIGHT

When flashing, the “OK” light indicates that the Eclipse-32 matrix is running normally.

④ CONFIGURATION “CONFIG” BUTTON

The Eclipse-32 matrix can hold four complete system configurations in its operational memory. Any one of the four configurations can be activated using the CONFIG button on the matrix front panel.

When one of the four configurations is active, its front-panel light illuminates steadily.

To select a new configuration

1. Repeatedly tap the CONFIG button until the desired configuration’s light (1,2,3, or 4) starts flashing.
2. While the desired configuration’s light flashes, press and hold the configuration button for three seconds, until the light stops flashing, and illuminates steadily.

The selected configuration then becomes the system’s active operational configuration.

If an invalid or blank configuration is chosen all four configuration lights steadily illuminate at the same time for about a second. The currently active configuration will continue to operate and its front-panel light steadily illuminates after the other lights go out.

⑤ CONFIGURATION STATUS LIGHTS

The four configuration status lights indicate which of the four onboard configurations is currently active. The currently active configuration’s light illuminates steadily.

⑥ POWER SUPPLY ALARM LIGHTS (1 AND 2)

An Eclipse-32 matrix has two internal power supply units. One power supply unit can power an entire matrix; the second unit provides a backup in case of an equipment failure.

In addition, the two supplies have separate IEC connectors to AC mains power, and are designed for completely automatic and transparent changeover between supplies in the event of an outage on one of the AC mains circuits.

The front-panel alarm lights do not illuminate under normal operating conditions.

The following conditions cause a power-supply alarm light to illuminate:

- If any of the voltages produced by the first power supply unit fall below normal levels.
- If any of the voltages produced by the second power supply unit fall below normal levels.

Once the power-supply fault condition is no longer present, the power-supply alarm light goes out.

⑦ LAN STATUS LIGHTS

When a local area network is connected to the matrix's LAN port, the LAN UP light steadily illuminates to indicate that the Eclipse-32 matrix is connected to a local area network. The Rx light flashes when data is being received.

⑧ PORT STATUS LIGHTS

Each port status light corresponds to an RJ-45 connector on the matrix's rear panel to which an external device, such as an intercom panel or interface, is connected. An illuminated port light indicates that a device is connected to that port, and that communications are running properly between the port and the matrix.

DEFAULT IP ADDRESS

From Eclipse 4.2 release onwards a factory default IP address (172.16.2.100) is set up in the matrix firmware which will always be available via an IP reset. This ensures that once the matrix firmware is loaded it will always be possible to access the matrix via ethernet even if the current IP address is not known.

To carry out an IP reset it is necessary to remove the cover of the Eclipse-32 in order to access the three reset switches positioned at the front left of the main circuit board (viewed from the front of the unit) shown in Figure 2-2. To carry out an IP reset press and hold the

rightmost two switches (nearest the side of the case) simultaneously and then press and release the 'RESET' button at the front of the unit, then release the internal switches. The unit will then be reset to the factory default IP address.

The unit cover should be replaced immediately the operation is completed.

Warning: As the unit must be powered when resetting the IP address this operation should only be carried out by qualified service personnel.

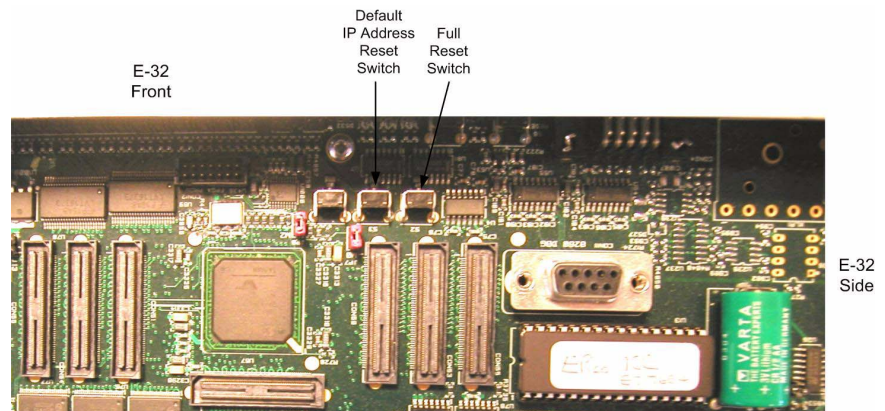

Figure 2-2: Eclipse-32 Reset Buttons

CONNECTING THE MATRIX TO REMOTE DEVICES

The Eclipse-32 matrix connects to remote devices such as intercom panels, interfaces, general purpose inputs and outputs, local area networks, and other matrices through its rear-panel hardware connectors.

The following sections describe the rear-panel connectors. The Installation Chapter of this manual gives pin assignments for each connector.

Note: General Purpose Outputs are also referred to as “relays.”

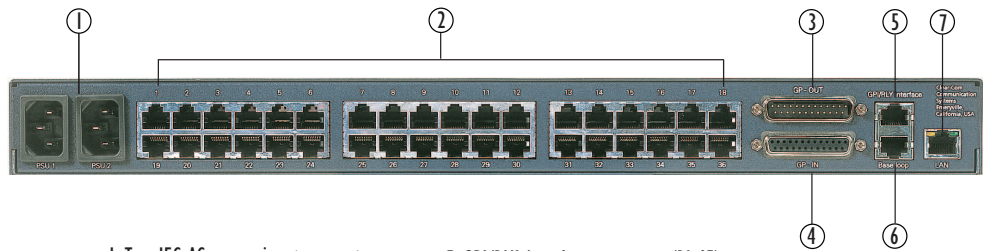

- 1 Two IEC AC power input connectors, (1 per power-supply unit)
- 2 RJ-45 port connectors (36)
- 3 General purpose outputs connector (male, 25-pin, D-type)
- 4 General purpose inputs connector (female, 25-pin, D-type)
- 5 GPI/RLY interface connector (RJ-45)
- 6 Base loop connector (RJ-45)
- 7 LAN connector (RJ-45)

Figure 2-3: Rear Panel of an Eclipse-32 Matrix

① CONNECTING TO AC POWER

An Eclipse-32 matrix's rear panel contains two IEC AC power input sockets for connecting AC mains power to the two power supplies. Each IEC socket connects cable to one power supply, operating at an input voltage of 100 to 240 volts, between 50 and 60 hertz.

② CONNECTING TO PANELS AND INTERFACES

An Eclipse-32 matrix's rear panel contains 36 RJ-45 sockets for connecting the matrix to remote intercom panels and interfaces. These sockets are often called “ports”. Each port socket is given a number on the rear-panel for easy identification.

All ports contain a voice detection mechanism (“VOX”) that is programmed from the Eclipse Configuration System software. VOX detection allows the panel operator to know when the audio on a particular channel has exceeded a threshold. This is particularly useful for channels that are inactive periodically, so that the panel operator is visually cued in the software when audio appears on the line.

Note: A shielded cable should be used.

③ CONNECTING TO GENERAL-PURPOSE OUTPUTS

The male 25-pin D-type socket labeled “GP OUT” allows the Eclipse-32 matrix to be connected to eight general purpose outputs (GPOs). General-purpose outputs are single-pole double-throw relays with contact ratings of 30 VDC (volts direct current) at 1 ampere.

A general purpose output or “relay” is a switch that is controlled remotely. The relay is programmed in the Eclipse Configuration System software to close a contact whenever an intercom panel’s key is pressed. When the contact is closed, it completes an electronic circuit’s signal path so that a remote device, such as a light, is powered.

A GPO can be programmed to mute a speaker, to turn on an applause light, to turn on a door lock, or to perform a variety of other functions. For example, to get the attention of a panel operator working in a high-noise environment such as a control booth a relay can be programmed to switch on a light at the panel each time the panel receives an incoming call to ensure that the call will not be missed.

Note: If the GP-OUT port is used the following filter must be fitted between the PROC-RCC socket and the cable:

**CINCH FA-25PS/1-LF 25W D-type in-line 1000pF filter
(UK supplier: Farnell 111-4108)**

Note: A shielded cable should be used.

④ CONNECTING TO GENERAL-PURPOSE INPUTS

The female 25-pin D-type socket labeled “GP IN” allows the Eclipse-32 matrix to be connected to eight general purpose inputs (GPIs).

An external logic device—such as an external foot switch, a panel-mounted switch, or the logic output of some other device— can be connected to the “GP IN” connector. When the external logic device is activated, it sends a control signal into the matrix to perform one of several preset functions, such as turning an intercom panel’s microphone on or off, muting a microphone’s output, or turning a panel’s speaker off. The function to perform, and the panel upon which it is performed is programmed from the Eclipse Configuration System software.

Note: A shielded cable should be used.

⑤ CONNECTING TO A GPI/RLY INTERFACE

The RJ-45 socket labeled “GPI/RLY Interface” connects the Eclipse-32 matrix to a GPI-6 or RLY-6 card. The GPI-6 provides six general-purpose opto-isolated logic inputs. The RLY-6 card provides six single-pole, double-throw relay outputs.

Both card types mount in either an IMF-3 interface frame or an IMF-102 interface frame. Up to ten GPI-6 or RLY-6 cards can be operated at one time from the matrix by daisy-chaining the cards together. Each card has an IN and an OUT connector for this purpose.

The RLY-6 and GPI-6 cards connect to the GPI/RLY interface connector using shielded category-5 cable. For more information about the GPI-6 and RLY-6 cards, consult their respective manuals.

Note: If this port is used a ferrite must be added to the socket end of the cable. A suitable ferrite is Würth Elektronik part: 74271132.

Note: A shielded cable should be used.

⑥ LINKING TO A SECOND ECLIPSE-32 MATRIX

Shielded category-5 (CAT-5) cable is connected from the “base loop” socket of one Eclipse-32 matrix to the “base loop” socket of a second Eclipse-32 matrix to form one non-blocking 64-port Eclipse matrix system. The cable connecting the two matrices can be up to 1 meter (3.28 feet) long.

The link is activated from the “My Systems” screen in the Eclipse Configuration System.

Note: To transfer data between two linked E-32 matrices using the high-speed link the Ethernet ports must be connected with either a cross-over shielded CAT-5 cable or a with a hub or switch using conventional shielded CAT-5 cable.

⑦ CONNECTING TO A LOCAL AREA NETWORK

The RJ-45 socket labeled “LAN” connects a local area network (LAN) to the Eclipse-32 matrix through a standard Ethernet connection.

Note: If this port is used a ferrite must be added to the socket end of each cable. A suitable ferrite is Würth Elektronik part: 74271132.

Note: A shielded CAT-5 cable should be used.

3

INSTALLING AN ECLIPSE-32 MATRIX

VERIFYING THE SHIPMENT

When the Eclipse-32 system is received inspect the boxes for shipping damage. Report any shipping damage to the carrier. The Eclipse-32 distributor is not responsible for shipping damage.

Check the packing list and verify that every item on the list has been received. Save all packing materials in the event any items need to be returned.

UNPACKING THE SYSTEM

The system will include an Eclipse-32 matrix which contains the hardware, and the software for the system. The user will need to supply:

- A standard 19 inch wide (48.26 cm) Electronics Industry Association rack in which to install the matrix.
- A personal computer to run the Eclipse Configuration System programming software (ECS). The Eclipse Configuration System software runs on Windows 2000, Windows XP, Windows Server 2003 and Windows Vista (with restrictions). When running ECS on Windows operating systems, the client and server can run on separate machines connected over a network.
- Shielded category-5 cables to connect to panels and interfaces.

INSTALLING THE ECLIPSE-32 MATRIX

The following overview gives a summary of the steps required to install an Eclipse-32 matrix. More detailed information on each step is provided in the sections that follow.

To install an Eclipse-32 matrix

1. Remove the Eclipse-32 matrix from its shipping carton.
2. Place the matrix in a standard Electronic Industry Association equipment rack.
3. Leave at least 2 inches (51 mm) of clearance on all sides of the matrix to ensure proper airflow. Do not block ventilation vents.
4. Connect the power supplies to AC mains power using the IEC connectors on the matrix's rear panel. The matrix has two separate AC power entry connectors for the two separate power supplies in the system.

A fully equipped Eclipse-32 matrix requires 100 to 240 VAC at 50 to 60 Hz with a maximum dissipation of 400 watts.

BATTERY BACKUP

The Eclipse-32 matrix is fitted with a non-rechargeable battery to maintain the system memory that stores the configuration maps and other system data in the event of power failure or the unit being switched off for a period of time.

The Eclipse-32 battery is normally a 1/2AA 3V VARTA 6127-201-301 and would be fitted on shipment. This has a capacity of 970mAh and a life of approximately 252 days.

Note: If the matrix is stored for more than three months, or if the AC power to the matrix is regularly turned off (as in Outside Broadcast vans), a qualified service person should be contacted to disconnect the CPU backup battery before storing the matrix. Disconnecting the backup battery preserves battery life. Only a qualified service person should attempt to disconnect the battery. To contact a qualified service person, please see the information in the Warranty chapter.

WIRING THE MATRIX TO REMOTE DEVICES

The matrix holds the circuitry for connecting to, and communicating with, the following:

- Thirty-two intercom panels or interfaces
- Eight general purpose outputs (GPOs or relays)
- Eight general purpose inputs (GPIs)
- Up to ten external GPI/RLY interfaces
- An additional Eclipse-32 matrix to form a 64-port linked system
- A local area network (LAN) connection for Ethernet-based communication with a network
- An external computer

The following sections describe the wiring for these connections.

Note: The instruction manual “Installing an Eclipse Matrix Installation Manual” (part 810298Z) gives complete details about wiring remote devices to the matrix. The manual also discusses RJ-45 cables and other types of cable required for system installation.

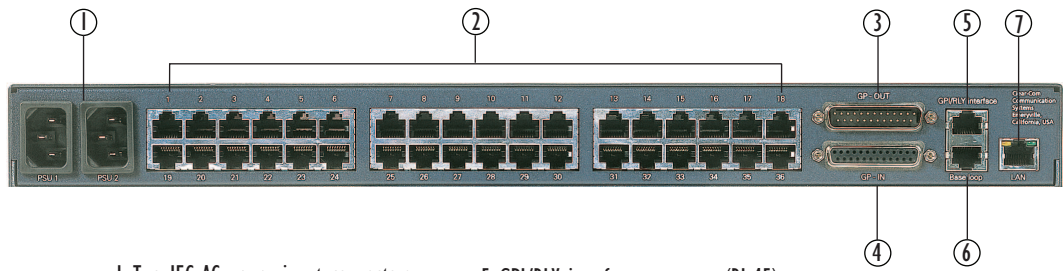

- | | |
|--|---------------------------------------|
| 1 Two IEC AC power input connectors,
(1 per power-supply unit) | 5 GPI/RLY interface connector (RJ-45) |
| 2 RJ-45 port connectors (36) | 6 Base loop connector (RJ-45) |
| 3 General purpose outputs connector
(male, 25-pin, D-type) | 7 LAN connector (RJ-45) |
| 4 General purpose inputs connector
(female, 25-pin, D-type) | |

Figure 3-1: Wiring Interfaces to Rear-Panel Connectors

① WIRING TO AC MAINS POWER

The Eclipse-32 matrix has two IEC mains AC power connectors that provide separate power inputs for the redundant power supplies. If each AC input is connected to a different mains AC branch, one power supply will continue to operate if the other supply's main AC branch fails.

② WIRING TO PANELS AND INTERFACES

Eclipse uses a 4-pair (analog) or single-pair (digital) wiring scheme between the matrix and panels. All Eclipse panels have built-in RJ-45 connectors.

4-Pair Analog

Four-pair analog wiring is done with shielded CAT5 RJ-45 cable.

- Pair 1 transmits analog audio from the matrix to the panel.
- Pair 2 transmits digital data from the panel back to the matrix.
- Pair 3 transmits audio from the panel to the matrix.
- Pair 4 transmits digital data from the matrix back to the panel.

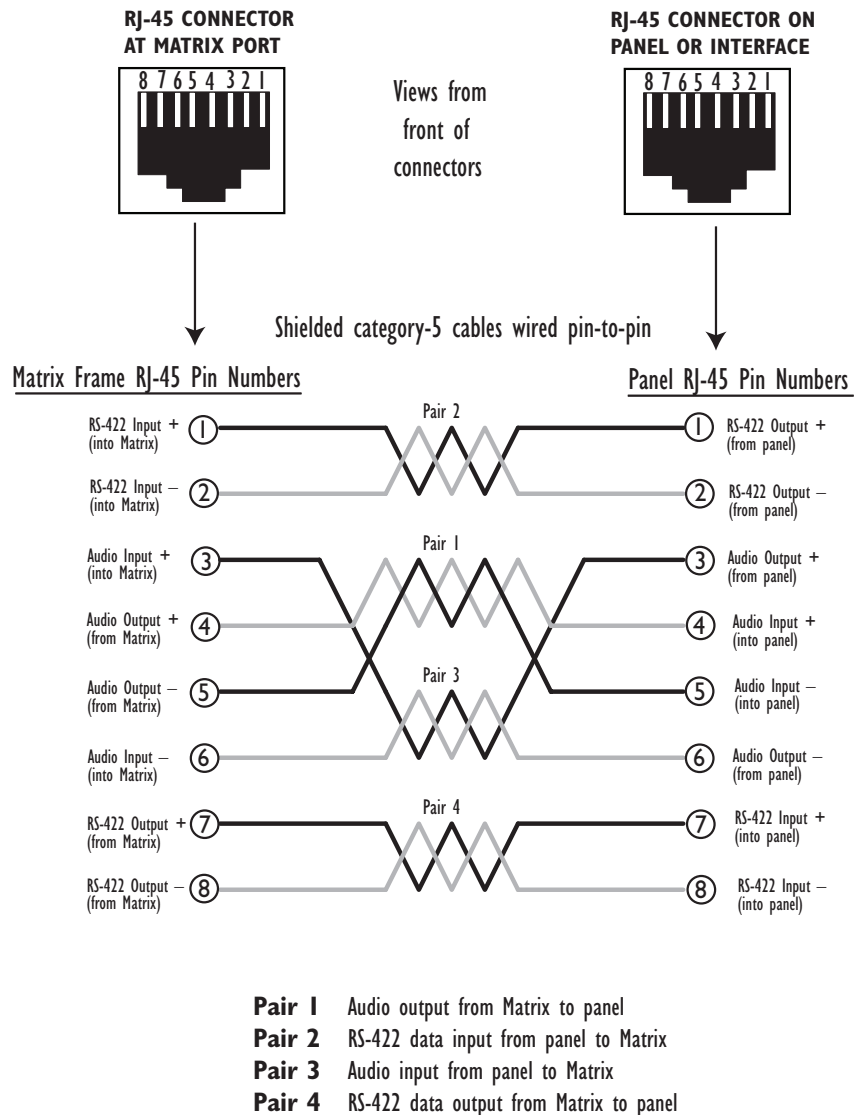

Figure 3-2: Wiring Matrix to Analog Panel Using RJ-45

③ WIRING TO 4-WIRE EQUIPMENT

Eclipse-32 uses a 2-pair analog wiring scheme between the matrix and 4-wire equipment. The wiring scheme shown in Figure 3-3 below is for 4-wire equipment with an RJ-45 connector. For 4-wire equipment with other types of connector the pin connections should be changed in accordance with the installation specification for the 4-wire equipment.

2-Pair Analog

Two-pair analog wiring to 4-wire equipment is done with shielded CAT5 RJ-45 cable if CAT5 cable is used or another suitable type of cable depending on the 4-wire equipment.

- Pair 1 is not used.
- Pair 2 transmits digital data from the 4-wire equipment back to the matrix.
- Pair 3 transmits audio from the 4-wire equipment to the matrix.
- Pair 4 is not used.

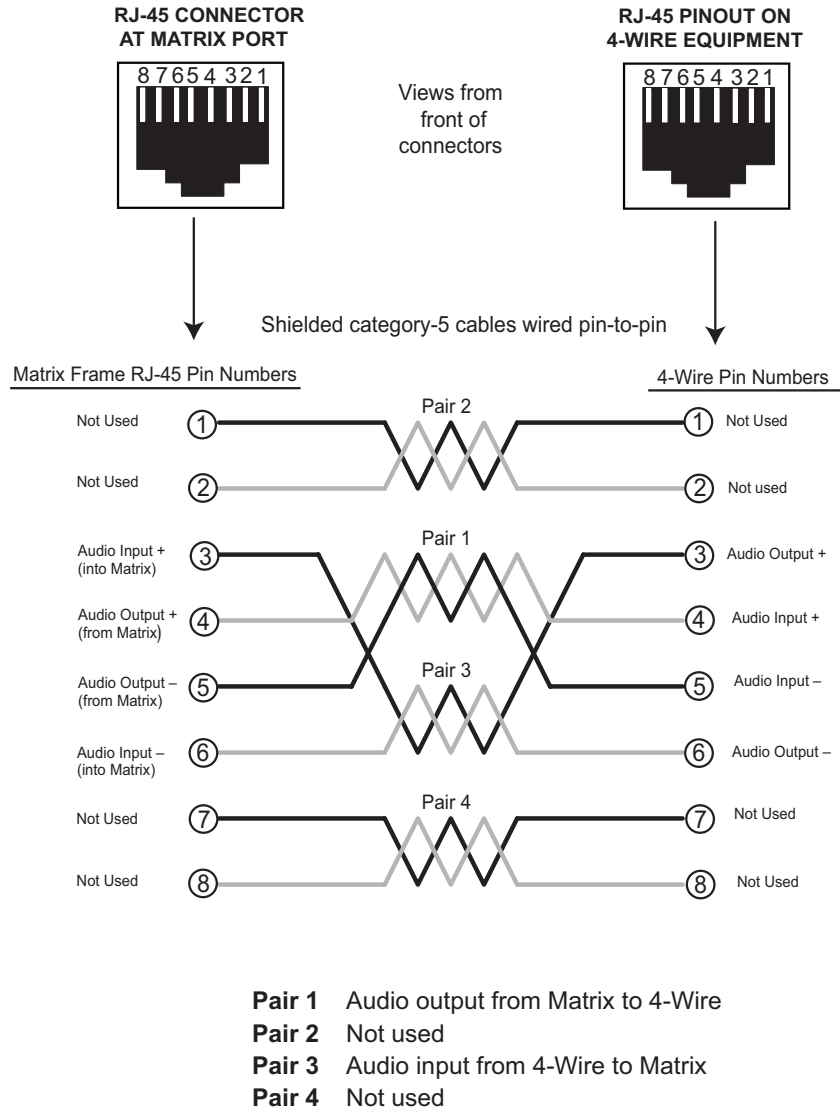

Figure 3-3: Wiring Matrix to 4-Wire Equipment Using RJ-45

Single-Pair Digital

Single-pair digital wiring is accomplished with double-shielded 24 AWG conductor CAT-6E enhanced STP cable in the case of a DIG-2 interface or CAT5 cable for the AES-6-CX interface. Pair 1 transmits and receives multiplexed digital and analog between the matrix frame and the panel.

Note: Ensure that the “select” switch on the panel’s rear is in the correct position for the intended use.

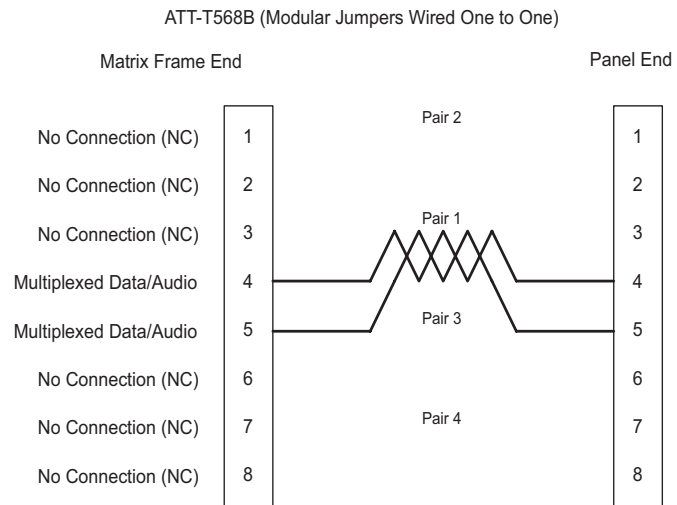

Figure 3-4: Wiring Matrix to Digital Panel Using RJ-45

④ WIRING GENERAL-PURPOSE OUTPUTS

The DB-25 connector labeled “GP OUT” allows connection to the Eclipse-32 matrix’s eight double-pole double-throw (DPDT) relays with contact ratings of 30 VDC at 1A.

Each general-purpose output has a relay inside the Eclipse-32 matrix. When a general-purpose output is inactive, the associated “common” pin on the GP OUT connector will be shorted to the relevant “normally closed” pin. When a general-purpose output becomes active, the short between the “common” pin and the “normally closed” pin is broken and a new connection is made between the “common” pin and the “normally open” pin.

DB-25 Male Connector

PIN	DESCRIPTION
1	RELAY 1 Common
2	RELAY 1 Normally Closed
3	RELAY 1 Normally Open
4	RELAY 2 Common
5	RELAY 2 Normally Closed
6	RELAY 2 Normally Open
7	RELAY 3 Common
8	RELAY 3 Normally Closed
9	RELAY 3 Normally Open
10	RELAY 4 Common
11	RELAY 4 Normally Closed
12	RELAY 4 Normally Open
13	GROUND
14	RELAY 5 Common
15	RELAY 5 Normally Closed
16	RELAY 5 Normally Open
17	RELAY 6 Common
18	RELAY 6 Normally Closed
19	RELAY 6 Normally Open
20	RELAY 7 Common
21	RELAY 7 Normally Closed
22	RELAY 7 Normally Open
23	RELAY 8 Common
24	RELAY 8 Normally Closed
25	RELAY 8 Normally Open

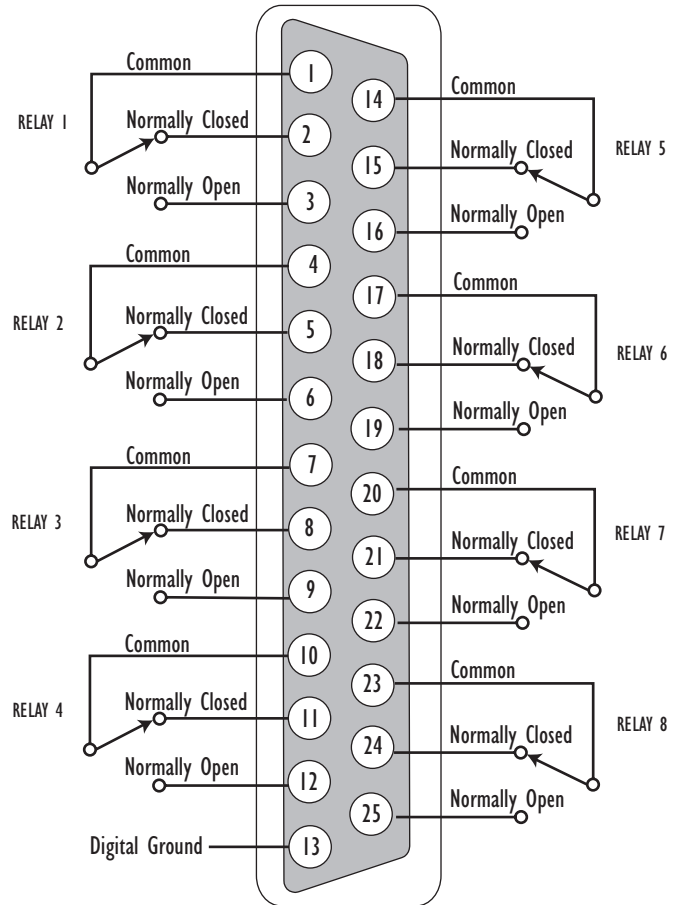

30 VDC at 1 Ampere

Figure 3-5: Pin Configuration of the General-Purpose Outputs Connector

⑤ WIRING GENERAL-PURPOSE INPUTS

The DB-25 connector labeled “GP IN” connects the matrix to eight local general-purpose inputs (GPIs).

When delivered from the factory, the general purpose inputs operate in non-isolated mode. The non-isolated mode does not require that the externally connected equipment powers the general-purpose input. The current is supplied by a voltage output on the “GP IN” connector.

Non-Isolated Mode

Figure 3-6 shows the non-isolated connection.

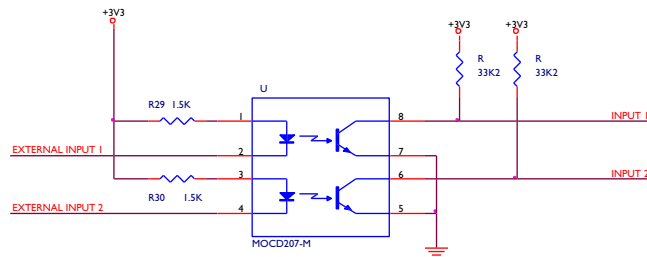

Figure 3-6: Non-Isolated Connection to Eclipse-32 GPI Connector

To cause an input to detect an active signal current must be sent from the relevant input pin.

The external device should draw no current to cause an inactive input and at least 5 mA to cause an active input. The opto-isolator drive line contains a 1.5 kOhm resistor to limit the current through the opto-isolator. It is therefore possible to connect the input pins directly to a ground pin to cause an active input.

The voltage level at the external input pin should not be allowed to go below ground or above +6 V with respect to ground.

Opto-Isolated Mode

If required the Eclipse-32 matrix can be operated in fully opto-isolated mode. The unit must be taken out of service and powered down before this change is made.

To operate the Eclipse-32 matrix in opto-isolated mode

1. If the Eclipse-32 unit is connected to AC power, disconnect it from AC power.
2. Remove the top cover of the Eclipse-32 matrix by unscrewing the 12 M3 x 6 flat screws and lifting the cover upwards.
3. On the internal circuit board, move the jumper located under the heading “J6” from pins 2-3 (marked “INT”) to pins 1-2 (marked “ISO”).

⚠ Warning: A circuit board’s components include CMOS chips that are sensitive to static electricity. Before touching the matrix’s circuit board touch a grounded metal object, such as any unpainted surface on the matrix, to dissipate static electricity. When handling a circuit board, be careful not to bend any of the board’s connector pins or component leads.

Figure 3-7 shows the opto-isolated connection.

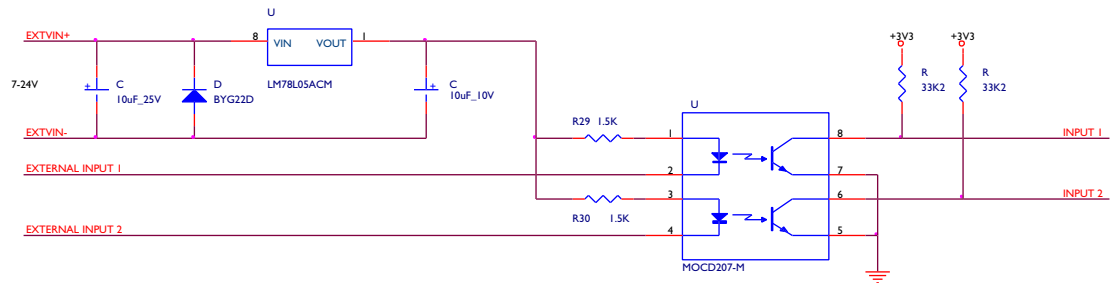

Figure 3-7: Opto-Isolated Connection to Eclipse-32 GPI Connector

In this mode, a DC voltage of between 7 and 24 volts is required at the EXTVIN+ pin with relation to the EXTVIN– pin. To cause an input to detect an active signal current must be sent from the relevant input pin.

The external device should draw no current to cause an inactive input and at least 5 mA to cause an active input. The opto-isolator drive line contains a 1.5 kOhm resistor to limit the current through the opto-isolator. It is therefore possible to connect the input pins directly to the EXTVIN– level to cause an active input.

The voltage level at the external input pin should not be allowed to go below EXTVIN– or above +6 V with respect to EXTVIN–.

Pin Assignments for General-Purpose Inputs Connector

DB-25 Female Connector

PIN	DESCRIPTION
1	Logic Input 1
2	Logic Input 2
3	Logic Input 3
4	Logic Input 4
5	N/A
6	N/A
7	N/A
8	N/A
9	Ground
10	Ground
11	Ground
12	Ground
13	Ground
14	Logic Input 5
15	Logic Input 6
16	Logic Input 7
17	Logic Input 8
18	N/A
19	N/A
20	N/A
21	N/A
22	Voltage In+
23	Voltage In+
24	Voltage In-
25	Voltage In-

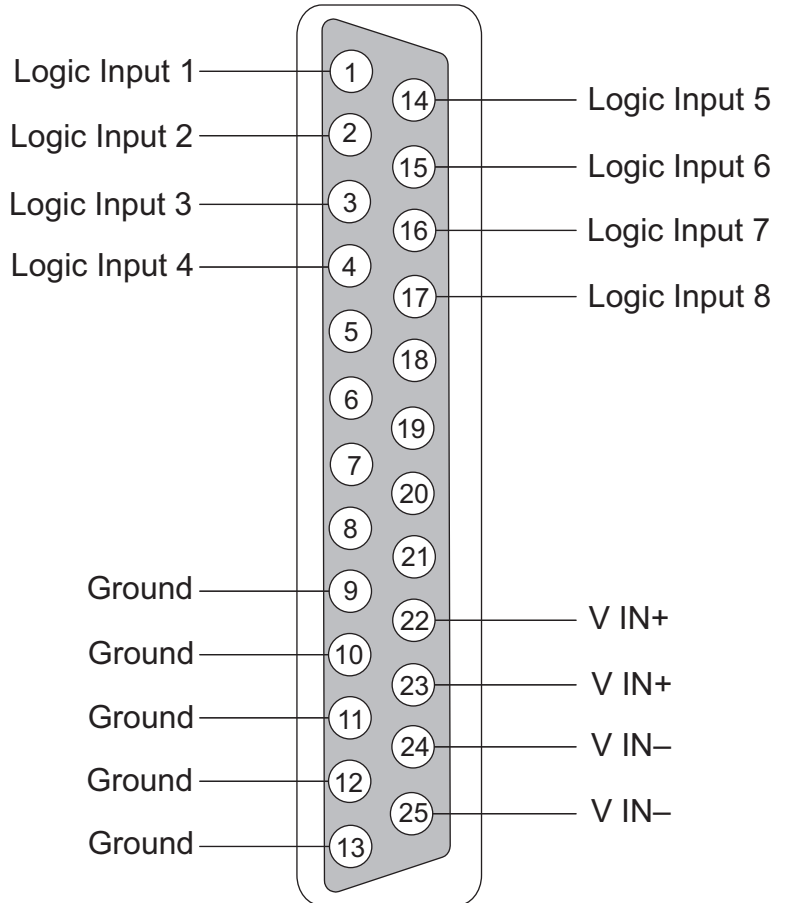

Figure 3-8: Pin Assignments for Eclipse-32 GPI Connector

⑥ WIRING TO A GPI/RLY INTERFACE

The RJ-45 connector labeled “GPI/RLY” connects up to 10 RLY-6 or GPI-6 interfaces to the matrix. RLY-6 and GPI-6 interfaces can be mixed together up to the total limit of 60 items. Five RLY-6 and five GPI-6 interfaces would provide 30 relays and 30 inputs for a total of 60 inputs and outputs.

Note: If both GPI-6 and RLY-6 interfaces are used the GPI-6 interfaces are required to be placed first in the daisy chain.

The following sections give an overview of the wiring of these interfaces. For more detailed discussion of wiring of interfaces in general, see the manual *Eclipse Matrix Installation Manual* (part 810298Z).

RLY-6 Interface Wiring

The RLY-6 relay interface module connects up to six programmable relays to the matrix so that each relay is directly controlled from the matrix. Multiple RLY-6 interfaces can be daisy chained to provide connection of up to 60 relays to the matrix.

IMF-3 Interface Module Frame Wiring

To Matrix

To connect the RLY-6 interface to the matrix, plug one end of an RJ-45 cable (eight wires with no reversal) into the GPI/RLY INTERFACE connector on the back of the matrix. Plug the other end into the top RJ-45 (CH. A MATRIX) connector for the RLY-6.

To connect an additional RLY-6 interface, plug one end of a short RJ-45 cable into the lower RJ-45 (CH. B MATRIX) for the first RLY-6. Then, plug the other end into the top RJ-45 (CH. A MATRIX) connector for the additional RLY-6. Additional RLY-6 interfaces are added in the same way, using daisy-chain wiring. If there are multiple RLY-6 interfaces, the relays in the first will be numbered 1 through 6, the second will be numbered 7 through 12, etc. If both GPI-6 and RLY-6 interfaces are used in the frame the GPI-6 interfaces must be placed before the RLY-6 interfaces (see Figure 3-9 below).

The maximum combined length of all the RJ-45 cables should not exceed 20 ft. (6 m).

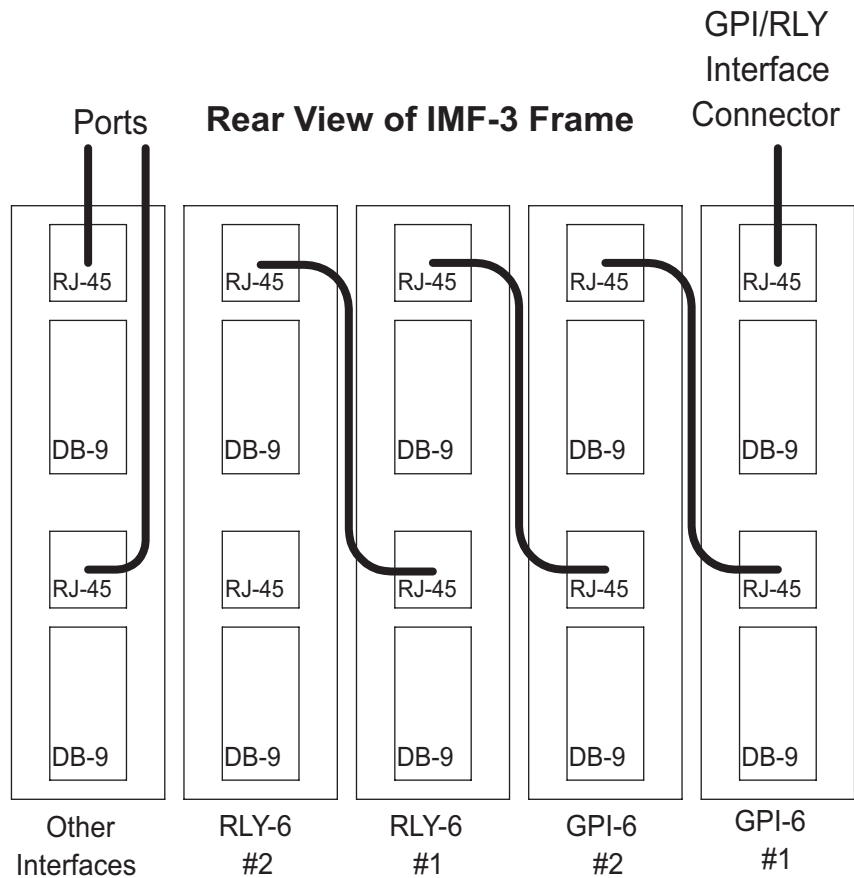

Figure 3-9: Rear View of IMF-3 Frame

To External Device

To connect external devices to the RLY-6 interface, use the two DB-9M connectors on the rear cable assembly panel for the interface. Figure 3-10 shows the pin assignment of these connectors as viewed from the matrix side of the connector.

If a DB-9F is plugged into the connector labeled CH. A I/O, relays 1 to 3 are available on that connector. The connector labeled CH. B I/O has the contacts for relays 4 to 6. In Figure 3-10, the labels on the pins apply to either connector. Example: #1/4 COM refers to the wiper of relay 1 if it is connected to CH. A and the wiper of relay 4 if it is connected to CH. B.

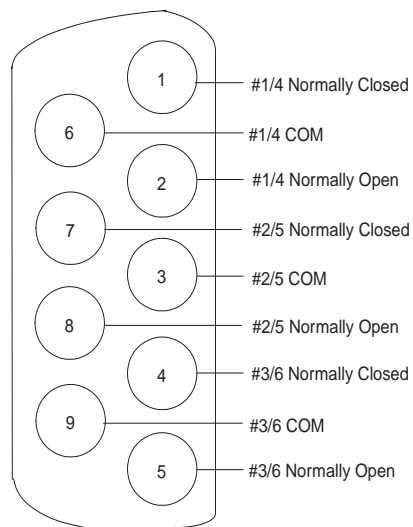

Figure 3-10: RLY-6 Interface DB-9M Connector Pinout

IMF-102 Interface Module Frame Wiring

The wiring of a RLY-6 interface that is placed in an IMF-102 interface frame is the same as the wiring for a RLY-6 interface placed in an IMF-3 interface frame. The only difference is that an IMF-102 interface frame houses only two interfaces, and they are mounted horizontally rather than vertically in the frame.

Refer to the respective manuals for these interfaces and frames in the Eclipse manual set for more information.

Configuration

To associate a relay to a label use the Eclipse Configuration System (ECS) as described in the ECS manual.

GPI-6 Interface Wiring

The GPI-6 input interface module connects up to six programmable inputs to the matrix so that each input can control a predefined matrix function. Multiple GPI-6 interfaces can be daisy-chained to provide connection of up to 60 inputs to the matrix. RLY-6 and GPI-6 interfaces can be mixed together up to the total limit of 60 items. Five RLY-6 and five GPI-6 interfaces would provide 30 relays and 30 inputs for a total of 60 inputs and outputs. If both GPI-6 and RLY-6 interfaces are used the GPI-6 interfaces are required to be placed first in the daisy chain.

IMF-3 Interface Module Frame Wiring

To Matrix

To connect the GPI-6 to the matrix, plug one end of an RJ-45 cable (eight wires with no reversal) into the GPI/RLY INTERFACE connector on the back of the matrix. Plug the other end into the top RJ-45 (CH. A MATRIX) connector for the GPI-6.

To connect an additional GPI-6 interface, plug one end of a short RJ-45 cable into the lower RJ-45 (CH. B MATRIX) for the first GPI-6. Then, plug the other end into the top RJ-45 (CH. A MATRIX) connector for the additional GPI-6. Additional GPI-6 interfaces are added in the same way, using daisy-chain wiring. If multiple GPI-6 interfaces are required the inputs in the first will be numbered 1 through 6, the inputs in the second will be numbered 7 through 12, etc. RLY-6 interfaces can be mixed in this daisy-chained scheme. The maximum combined length of all the RJ-45 cables should not exceed 20 ft. (6 m).

To External Device

To connect external devices to the GPI-6 interface, use the two DB-9M connectors on the rear cable assembly panel for the interface. Figure 3-11 shows the pin assignment of these connectors as viewed from the matrix side of the connector.

If a DB-9F is plugged into the connector labeled CH. A I/O, inputs 1 through 3 are available on that connector. The connector labeled CH. B I/O has inputs 4 through 6. In Figure 3-11, the labels on the pins apply to either connector.

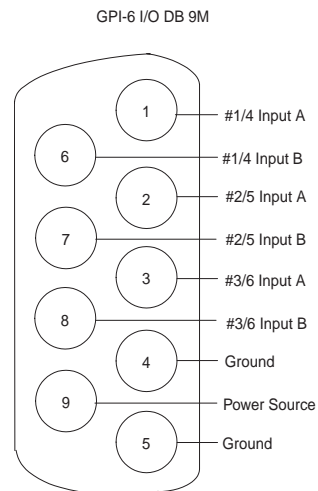

Figure 3-11: GPI-6 Interface DB-9M Connector Pinout

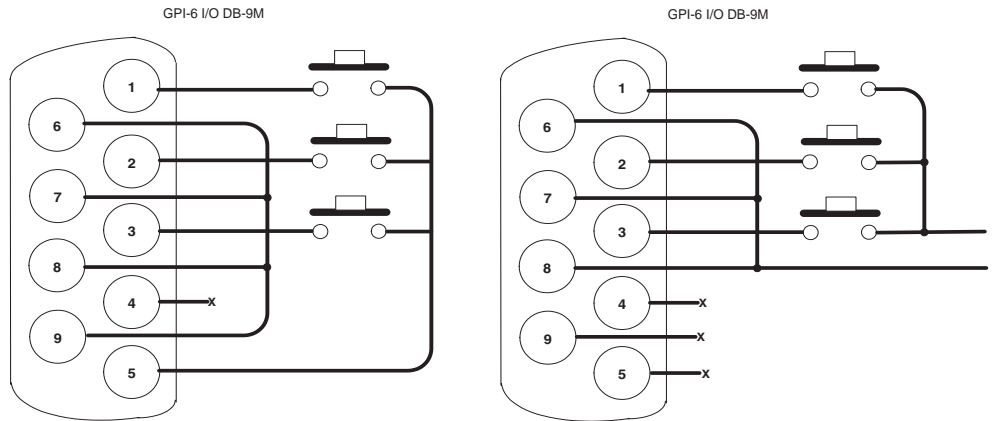

Figure 3-12: GPI-6 Application Examples

Figure 3-11 and Figure 3-12 show how to connect switches or contacts using the power source provided by the GPI-6 module or powering switches from external sources. Each input can be wired to be isolated from each other as a further variation.

IMF-102 Interface Module Frame Wiring

The wiring of a GPI-6 interface that is placed in an IMF-102 interface frame is the same as the wiring for a GPI-6 interface placed in an IMF-3 interface frame. The only difference is that an IMF-102 interface frame houses only two interfaces, and they are mounted horizontally rather than vertically in the frame.

Refer to the respective manuals for these interfaces and frames in the Eclipse manual set for more information.

Configuration

To define an input function, use the Eclipse Configuration System program, as described in its manual.

⑦ WIRING TO A SECOND ECLIPSE MATRIX

The RJ-45 connector labeled “Base Loop” connects the Eclipse-32 matrix to a second Eclipse-32 matrix’s “Base Loop” connector to form one non-blocking 64 port Eclipse system.

To make this connection, use a specially constructed screened CAT-5 cable of maximum length 1 meter (3.28 feet). The cable is wired as shown in Table 3-1.

NOTE: If the ECS computer does not have a serial port, and only offers USB, adapters are generally available from computer parts suppliers.

Cable end 1	wire color	cable end 2
Pin 1	white/orange	Pin 3
Pin 2	orange	Pin 6
Pin 3	white/green	Pin 1
Pin 4	blue	Pin 4
Pin 5	white/blue	Pin 5
Pin 6	green	Pin 2
Pin 7	white/brown	Pin 7
Pin 8	brown	Pin 8

Table 3-1: Pin Configuration of Base Loop Connector

⑧ WIRING TO A LOCAL AREA NETWORK

The LAN connector has standard Ethernet pin assignments.

LAN1 and LAN2
Ethernet RJ-45 Connectors

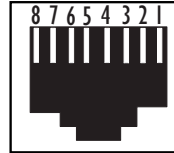

PIN	FUNCTION
1	Transmit data +
2	Transmit data -
3	Receive data +
4	Unused
5	Unused
6	Receive data -
7	Unused
8	Unused

Figure 3-13: Pin Assignments for LAN Connector

WIRING TO A COMPUTER

The DB-9 connector labeled “PC” connects the Eclipse-32 matrix to an external computer. This connector is located on the Eclipse-32 matrix’s front panel.

To connect a computer to the matrix, run cable from the matrix’s “PC” connector to the PC’s serial port. The maximum recommended length of the cable is approximately 10 feet (3 meters).

A computer has either a 9-pin serial port or a 25-pin serial port. Figure 3-14 shows the wiring for a 9-pin port. Figure 3-15 shows the wiring for a 25-pin port.

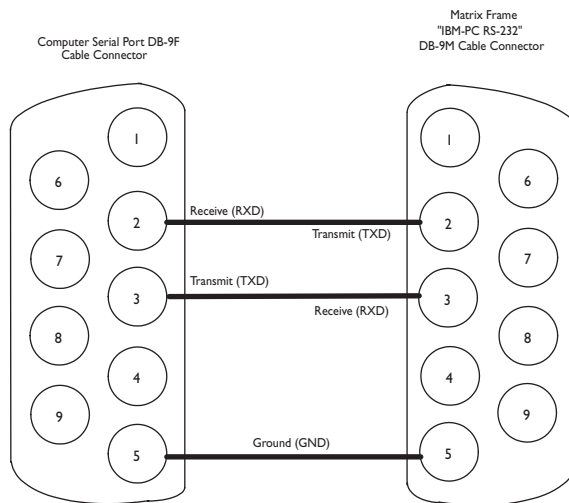

Figure 3-14: Wiring the Matrix DB-9M to a DB-9F Computer Serial Port Connector

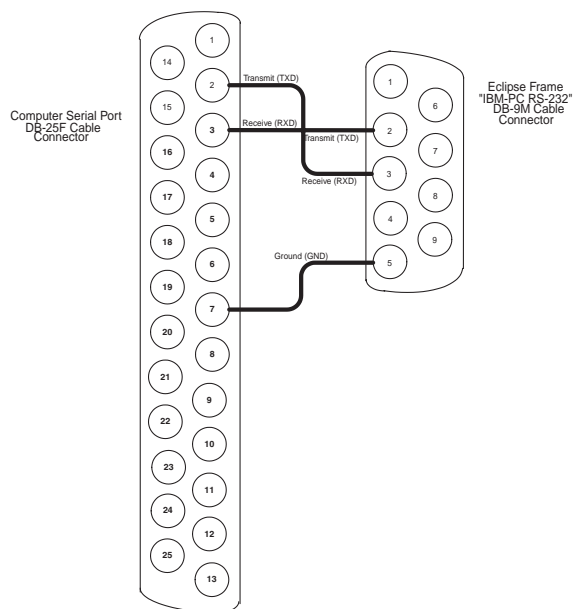

Figure 3-15: Wiring the Matrix DB-9M to a DB-25F Computer Serial Port Connector

4 MAINTENANCE

RECOMMENDED SPARE PARTS

To facilitate quick repair of the system with minimum downtime, Clear-Com recommends keeping the following spare system components in good working condition at all times:

- One of each type of intercom panel in the system
- One of each type of interface in the system

Due to the complexity of the system, field service generally should be limited to isolating the specific component of the system with the problem.

DUAL, INDEPENDENT POWER SUPPLIES

The Eclipse-32 matrix includes two internal power supply units. One power supply unit can power an entire matrix; the second unit provides a backup in case of an equipment failure.

In addition, the two supplies have separate IEC connectors to AC mains power, and are designed for completely automatic and transparent changeover between supplies in the event of a power failure on one of the AC branches.

5

SPECIFICATIONS

dBu is an absolute measurement. 0 dBu is referenced to 0.775 volts RMS

General

Height	44 mm or 1.75 inches (1 RU)
Width	482 mm (19 inches)
Depth	300 mm (12 inches)
Weight	5 kg max.
Power Consumption	60W Max. per inlet
Number of Panel Compatible Ports	32
Number of Analog Audio Ports	4
Number of Expansion Modules	1
Number of Power Supply Units	2
Maximum Number of Ports Per System	72 with 2 Eclipse-32 units; 64 panel ports

Matrix Performance

Sample Rate	48 kHz
Resolution	24 bit
Frequency Response @ 48 kHz sampling	30 Hz – 22 kHz \pm 3 dBu
Crosstalk (adjacent channel)	<-70 dBu
Nominal Level	0 dBu
Matrix headroom	18 dBu
Distortion	<0.05 %, @ 0 dBu, 300 Hz to 10 kHz; <0.1 %, @ 0 dBu, 100 Hz to 20 kHz
Off Noise	<-98 dBu relative to +18 dBu, 20 Hz - 22kHz
On Noise	<-83 dB relative to +18 dBu, 20 Hz - 22 kHz
Key Response, Intra-System	<40 ms for audio route
Linked Systems	<60 ms for audio between matrices
Temperature	0 to +40 ° C, ambient; -55 ° to +70 ° C, storage
Humidity, Maximum	90% non-condensing

Matrix Interfaces

GPI inputs	8 total; opto-isolated
GPI outputs (relays)	8 total; isolated relay contacts
GPI connector	25-pin D-type socket on rear panel
GPO connector	25-pin D-type plug on rear panel
External GPI-6/RLY-6	RJ-45 on rear panel

Network	10/100 Base-T Ethernet maximum distance: 100 meters connector RJ-45
Serial PC	RS-232 Baud rate: 57600 Maximum distance: 10 meters Number of ports: 1 Connector: 9-way D-type socket on front

System Programming

Crosspoint Level Control	0.355 dB steps
Input Level Control	0.355 dB steps
Output Level Control	0.355 dB steps
VOX Input Detection Threshold	0 dB to – 40 dB adjustable

Minimum PC Requirements

Processor	Pentium III 600 MHz
Memory	512 MB RAM
Hard Disk	500 MB free space
Input Devices	CD-ROM Drive
Display Resolution	SVGA
User Entry	Keyboard, Mouse
Ports	2 serial ports and/or network IEEE 802.3 Ethernet card
Network	IEEE 802.3 Ethernet Card
Operating Systems	Windows 2000 / Windows XP / Windows 2003 Server / Windows Vista (with restrictions)

Recommended PC Requirements

Processor	Pentium III 800 MHz or greater
Memory	1GB or greater
Free Space	500 MB
Display Resolution	1600 X 1200
Operating Systems	Windows 2000 / Windows XP / Windows 2003 Server / Windows Vista (with restrictions)

Power Supply Unit

Quantity	2 per matrix
Mounting	Internal
AC Power Input	IEC (1 per PSU)
Input Voltage	AC 100 V to 240 V, 50/60 Hz
Power Consumption	60 W maximum
Alarm Indicators	LEDs viewable from front of rack

Supported Panels and Interfaces: ICS-1008, ICS-1016, ICS-52, ICS-92, ICS-62, ICS-102, IMF-102, ICS-2003, i-Station family, XPL-22, XPL-12, IMF-3, TEL-14, CCI-22, FOR-22, RLY-6, GPI-6, DIG-2, AES-6, 4000 Series II Panels, V-Series Panels.

Notice About Specifications

While Clear-Com makes every attempt to maintain the accuracy of the information contained in its product manuals, that information is subject to change without notice. Performance specifications included in this manual are design-center specifications and are included for customer guidance and to facilitate system installation. Actual operating performance may vary.

6 GLOSSARY

Analog Port Any of the Eclipse matrix's analog input/output RJ-45 connectors that are used to connect cable from the matrix to panels and interfaces. Each "port" connects to a separate audio channel in the matrix intercom system.

Bus A bus is the channel or path between the components in the matrix along which electrical signals flow to carry information from one component to the next. In the Eclipse matrix the bus is located in the etched surface of the midplane.

Call Signal A call signal is an electronic signal sent from one panel or interface to another. A call signal can be audible and/or visual. Typically a call signal is sent to get the attention of a panel operator who may have turned down their intercom speaker's volume or removed their headset. It can also be sent to activate an electronic relay.

Category-5 cable EIA/TIA 568 category specification relating to network cabling. Shielded category-5 cabling is required for Eclipse matrix wiring.

CellCom Digital wireless communications product. Sold under the CellCom name in USA and as FreeSpeak in Europe and Asia.

Central Matrix The term "central matrix" is used to differentiate the central hardware and software of the intercom system from the connected audio devices. The central matrix consists of:

1. The metal housing for the circuit cards and power supplies.
2. The circuit cards.
3. The power supplies.
4. The rear panel connectors which connect the matrix's hardware to panels and interfaces.

Destination A device such as an intercom panel, beltpack, or interface to which audio signals are sent. The device from which audio signals are sent is called a "source".

Duplex All real-time communication between individuals talking face to face is full duplex, meaning that they can both talk and listen simultaneously. The Eclipse Omega matrix provides full-duplex audio.

ECS Eclipse Configuration System. Software program that guides the operation of the central matrix circuit cards and connected panels.

EMS Element Management System. Software program that is used to manage the Concert server system resources.

Ethernet International standard which describes how information is transmitted across a network. Provides for the efficient organization of network components.

Fiber-optic Cable A fiber-optic cable consists of a glass core covered with a reflective material called “cladding” and several layers of buffer coating to protect the cable from the environment. A laser sends light pulses through the glass core to the other end of the cable.

FreeSpeak Digital wireless communications product. Sold under the FreeSpeak name in Europe and Asia and CellCom in USA.

Full Duplex Refers to transmission of signals in two directions simultaneously.

IFB “Interruptible Foldback”. The term “foldback” refers to sending “program” audio, or some other audio mix, back to announcers while they are on the air. Doing so allows announcers to monitor themselves, other announcers, videotapes of commercials, or some mix of sources, while they on the air. This is typically found in television news and live broadcast events.

Announcers typically wear a small ear piece so they can hear the selected foldback audio mix. When a director wants to give directions to an announcer on air, or to announce changes in the program, the director must “interrupt” the foldback. To do this, the director uses a channel specifically set up to interrupt the foldback audio.

Interface Module A piece of electronic hardware designed to convert the 4-wire signals of a central matrix port to some other form of communication, such as 2-wire party line, telephone, etc. The interface module is connected to a central matrix port. The external non-4-wire device is then connected to the interface module.

ISO The ISO function, short for “panel ISOLation”, allows a panel operator to call a destination and interrupt all of that destination’s other audio paths and establish a private conversation. When the call is completed the destination’s audio pathways are restored to their original state before the interruption.

IV-R Instant Voice Router. Software that routes digital audio data between Concert users and between Concert users and Eclipse systems.

Label A label is an alphanumeric name of up to five characters that identifies a source, destination, or control function accessed by an intercom panel. Labels appear in the displays of the intercom panel. Labels can identify panels, ports interfaced to other external equipment, fixed groups, party lines, and special control functions.

Mode A term used to describe a light path through a fiber as in multimode or single mode.

Multimode Fiber-optic Cable The glass core of a multimode fiber is larger than the core of a single mode fiber, which causes the transmitted light beam to disperse as it travels through the core. Single mode fiber, with its smaller core, concentrates the light beam so that it carries signals further. Multimode fiber was the first type of fiber offered

by manufacturers. Single-mode fiber evolved as production methods improved.

Multiplexing The process by which two or more signals are transmitted over a single communications channel. Examples include time division and wavelength division multiplexing.

Nanometer (nm) Common unit of measure for wavelength. One billionth of a meter.

Non-volatile Memory Data stored in the CPU's firmware (ROM) that is not lost when the power is turned off.

Optical Signal A laser at one end of a fiber-optic cable pulses on or off to send a light signal through the glass core of the cable to the other end of the cable. Because the light signals are binary (on or off), the signal is digital.

Panel Also referred to as "station" in some cases (usually older manuals). Any intelligent intercom device connected to the rear-panel analog ports of the central matrix. This term does not refer to devices connected through interface modules.

Port Any of the input/output connections (RJ-45 connectors) on the back panel of the central matrix. These connectors and the attached cables connect the central matrix to remote intercom devices. The term "port" emphasizes that the connection is a "portal" between the central matrix and the remote intercom devices.

Program Any separate audio source that is fed into the intercom channels. In television applications, for example, "program" audio is the audio that is broadcast on air.

Rack Unit or RU Standardized unit of mounting space on a rack panel. Each rack unit is 1.75 inches (44.45 mm) of vertical mounting space. Therefore 1 RU is 1.75 inches (44.45 mm) of vertical mounting space, 2 RU is 3.5 inches (88.9 mm), 3 RU is 5.25 inches (133.35 mm), and so on.

Remote Panel Any intelligent intercom device connected to the back-panel ports of the central matrix. This term does not refer to devices connected through interfaces.

Sidetone The sound of the panel operator's own voice heard in their own earphone as they speak.

Single-mode Fiber-optic Cable The glass core of a single-mode fiber is smaller in diameter than the core of a multimode fiber, so that the light signal transmitted over the core is more concentrated than with multimode fiber, which allows the signal to travel further. Single-mode fiber evolved from multimode fiber as production methods improved.

Source In this manual, the term "source" refers to a device—such as an intercom panel, interface, or beltpack—that sends audio into the matrix. The device to which audio is sent is called a "destination".

VOX In the Eclipse system, when audio at a panel exceeds a threshold, a light switches on at the panel's port card to visually cue the operator. The threshold level is set in the Eclipse Configuration Software.

V-Series Communications panels used with Eclipse systems providing advanced facilities. Available in rack mount and desktop formats.

Wavelength-division Multiplexing (WDM) A method of multiplexing optical signals developed for use on fiber-optic cable. Each signal is assigned a particular wavelength on the light spectrum and therefore many signals can be transmitted simultaneously without interfering with each other.

ECLIPSE MANUALS

The following manuals are available covering Eclipse products and accessories.

SOFTWARE MANUALS

Eclipse Configuration System (ECS) Instruction Manual - 810299Z

Eclipse Logic Maestro Instruction Manual - 810414Z

Eclipse Production Maestro Quick Start Guide - 810409Z

Eclipse Production Maestro Installation and User Guide - 810410Z

Eclipse DECTSync Manual - 810412Z

Eclipse Host Computer Interface (HCI) Manual - 810413Z

HARDWARE MANUALS

Eclipse Omega Matrix Instruction Manual - 810290Z

Eclipse Median Matrix Instruction Manual - 810347Z

Eclipse PiCo Matrix Instruction Manual - 810348Z

Eclipse-32 Matrix Instruction Manual - 810315Z

Eclipse Matrix Installation Manual - 810298Z

Eclipse Upgrade Reference Manual - 810377Z

Eclipse V-Series Panels User Manual - 810365Z

Eclipse FOR-22 4-Wire Interface Instruction Manual - 810306Z

Eclipse CCI-22 Party Line Interface Instruction Manual - 810307Z

Eclipse TEL-14 Telephone Interface Instruction Manual - 810308Z

Eclipse GPI-6 General Purpose Inputs Instruction Manual - 810309Z

Eclipse RLY-6 General Purpose Outputs Instruction Manual - 810310Z

DIG-2 Digital Interface Instruction Manual - 810311Z

IMF-3, IMF-102, DIF-102 Interface Module Frame Instruction Manual - 810313Z

Eclipse AES-6 Digital Interface Instruction Manual - 810383Z

Eclipse BAL-8 Isolation Interface Instruction Manual - 810403Z

Eclipse V-Series AES-3 Option Card Installation Instructions - 810388Z

Eclipse V-Series XLR-7M Upgrade Instructions - 810405Z

Eclipse V-Series T-Adapter Installation Instructions - 810406Z

Eclipse FIM-202D Fiber Interface Instruction Manual - 810385Z

Eclipse FIM-102 Fiber Interface Instruction Manual - 810319Z
Eclipse FIM-108 Fiber Interface Instruction Manual - 810291Z
Eclipse 4000 Series II Panels Installation Guide - STA0530Z
Eclipse 4000 Series II Panels User Guide - STA0531Z
Eclipse ICS 1008E/1016E Panels Instruction Manual - 810404Z
Eclipse ICS 102/62 Panels Instruction Manual - 810302Z
Eclipse ICS 2003 Panel Instruction Manual 810303Z
Eclipse ICS 92/52 Panels Instruction Manual - 810301Z
Eclipse i-Station Instruction Manual - 810305Z
Eclipse ICS-21 Speaker Panel Instruction Manual - 810263Z
Eclipse ICS-22 Speaker Panel Instruction Manual - 810264Z
Eclipse ICS-24 Headset Panel Instruction Manual - 810265Z
Eclipse Digital Wireless Beltpack Instruction Manual - 810376Z

LIMITED WARRANTY

This document details the Clear-Com Standard Limited Warranty for all new products for sale within all regions with the exception of Military, Aerospace, and Government (MAG).

EXCEPT AS SET FORTH HEREIN ("LIMITED WARRANTY"), CLEAR-COM MAKES NO OTHER WARRANTIES, EXPRESS, IMPLIED OR STATUTORY, INCLUDING WITHOUT LIMITATION ANY WARRANTIES OF MERCHANTABILITY, NONINFRINGEMENT OF THIRD PARTY RIGHTS, OR FITNESS FOR A PARTICULAR PURPOSE, ALL OF WHICH ARE EXPRESSLY DISCLAIMED.

1. **Standard Limited Warranty.** Clear-Com Communication Systems ("Clear-Com") warrants its products, including supplied accessories, against defects in material or workmanship for the time periods as set forth below provided it was purchased from an authorized Clear-Com dealer or distributor.

a) Pursuant to this Limited Warranty, Clear-Com will, at its option:

- i) repair the product using new or refurbished parts, or;
- ii) replace the product with a new or refurbished product.

b) Remedies: In the event of a defect, the rights detailed in 1 (a) are your exclusive remedies. For purposes of this Limited Warranty, "refurbished" means a product or part that has been returned to its original specifications.

c) Standard Warranty Period (by Product):

- i) All Clear-Com brand systems and products, including belt packs, have a Limited Warranty of two years, with the exception of;
 - (1) Cables, accessories, components & consumable items have a Limited Warranty of 90 days.
 - (2) Any Clear-Com product that has been classified as obsolete at the time of sale has a Limited Warranty of 90 days from sales and will be replaced with the same product or a sales credit will be issued, at the sole discretion of Clear-Com.
 - (3) Headsets, handsets, microphones, and associated spare parts, as well as UHF wireless IFB products, have a Limited Warranty of one year.
 - (4) UHF WBS Analog wireless intercom systems have a Limited Warranty of three years.

- (5) All software products, including Concert (Client and Server), ECS, Production Maestro and Logic Maestro are warranted for one year and shall substantially conform to published specifications. The media on which the Software is furnished is warranted to be free of defects in material and workmanship (under normal use) for a period of one year.
 - (6) Any Clear-Com products that are listed within the last time buy period have the same Limited Warranty for their type 1.i.1 - 1.i.5 as above.
- d) Any Clear-Com product that is repaired or supplied as a replacement under the terms of this Limited Warranty shall inherit the remaining warranty period from the original product.
- e) Standard Warranty Period Start Date
- i) Dealer / Distributor Sales: In view of Dealer or Distributor stocking practices, the Standard Warranty Period for products sold through Dealers or Distributors will commence from the Clear-Com invoice date and will include an automatic extension of three months. Any valid warranty claim within the Standard Warranty Period as determined by the Clear-Com invoice date will be covered without further supporting evidence. All warranty claims after this date must be supported by the Customer's proof of purchase that demonstrates the product is still within the Standard Warranty Period (as detailed in Section 1.c.i above, plus the automatic three month extension) from their purchase date.
 - ii) Direct Sales: The Standard Warranty Period will commence from the date the product was shipped from Clear-Com to the Customer. The Standard Warranty Period start date for contracts that include commissioning will be the date of the Site Acceptance Test (SAT) or one month from conclusion of the commissioning project, whichever is earlier.
- f) Invalidation of Warranty
- i) This Limited Warranty shall be invalidated if the product's outer case has been opened and internal modifications have been made or damage has occurred, or upon the occurrence of other damage or failure not attributable to normal wear and tear. Authorized modifications with Clear-Com's express written permission will not invalidate the warranty.
- g) Software Updates
- i) Software Updates are released periodically to correct discovered program bugs. During the Warranty Period, software updates are available to Customers free of charge.

h) Software Upgrades

- i) Software Upgrades include new Features and/or Functional Enhancements and are not included as part of the Standard Warranty but may be purchased at the published rates.
- ii) Note: In the absence of a Software Update containing a program correction and no available workaround to mitigate the problem, at the discretion of Service, Sales, Engineering, or Product Management, the Customer may be provided a Software Upgrade under warranty.

2. **Exclusions.** Services do not cover damage or failure caused by any occurrence beyond Clear-Com's reasonable control, including without limitation acts of God, fire, flooding, earthquake, lightning, failure of electric power or air conditioning, neglect, misuse, improper operation, war, government regulations, supply shortages, riots, sabotage, terrorism, unauthorized modifications or repair, strikes, labor disputes or any product failure that Clear-Com determines is not a result of failure in the Services provided by Clear-Com. Further Services excluded from this Agreement include: services required due to errors or omissions in Customer purchase orders; installation or maintenance of wiring, circuits, electrical conduits or devices external to the products; replacement or reconditioning of products which, in Clear-Com's opinion cannot be reliably maintained or properly serviced due to excessive wear or deterioration; Customer's failure to maintain the installation site in accordance with the environmental specifications of the products; or service on products removed from the location originally specified by Customer and/or reinstalled without the prior written approval of Clear-Com. Customer will pay Clear-Com's then current published charges to restore such Covered Products to a condition eligible for further service under this Agreement. Clear-Com shall be excused from and shall not be liable for any failure or delay in performance under this Agreement due to the foregoing or any causes beyond its reasonable control.

3. **Limitation of Liability.** IN NO EVENT WILL CLEAR-COM BE LIABLE UNDER THIS AGREEMENT FOR ANY INDIRECT, SPECIAL, INCIDENTAL OR CONSEQUENTIAL DAMAGES (INCLUDING WITHOUT LIMITATION LOST PROFITS), REGARDLESS OF THE FORM OF ACTION, EVEN IF ADVISED IN ADVANCE OF THE POSSIBILITY OF SUCH DAMAGES.

4. **Assignment.** Neither party may assign this Agreement or any portion thereof without the prior written consent of the other, except in the event of a merger, sale of all or substantially all of the assets or other corporate reorganization.

5. **Ownership of replaced parts or product.** All replaced parts or products become the property of Clear-Com.

6. **Entire Agreement.** This Agreement constitutes the entire agreement between the parties with respect to the subject matter hereof, and supersedes all prior or contemporaneous proposals, oral or written, and all other communications between them relating to the subject matter of this Agreement.

TECHNICAL SUPPORT & REPAIR POLICY

NOVEMBER 1, 2008

In order to ensure that your experience with Clear-Com and our World Class products is as beneficial, effective and efficient as possible, we would like to define the policies and share some "best practices" that can accelerate any problem solving processes which we may find necessary and to enhance your customer service experience. Our Technical Support, Return Material Authorization, and Repair Policies are set forth below. These Policies are subject to revision and constantly evolve in order to address our Customers' and the Market's needs. Accordingly these are provided by way of guidance and for information only and may be changed at anytime with or without Notice.

TECHNICAL SUPPORT POLICY

- a) Telephone, online, and e-mail technical support will be provided by the Customer Service Center free of charge during the Warranty Period.

- b) Technical support will be provided free of charge for all software products under the following conditions:
 - i) The application, operating, and embedded software is installed on a product covered by Clear-Com's Limited Warranty, and:
 - (1) The software is at the current release level; or,

 - (2) The software is one (1) version removed from current.

 - ii) Older versions of software will receive "best-effort" support, but will not be updated to correct reported bugs or add requested functionality.

- c) For Technical Support:
 - i) North and South America, (inc. Canada, Mexico, and the Caribbean) & US Military:
 - Hours: 0800 - 1700 Pacific Time
 - Days: Monday - Friday
 - Tel: +1 510 337 6600
 - Email: CustomerServicesUS@vitecgroup.com

 - ii) Europe, the Middle East and Africa:
 - Hours: 0800 - midnight Central European Time

Days: Monday - Friday
Tel: +49 40 853 999 700
Email: TechnicalSupportEMEA@vitecgroup.com

iii) Asia-Pacific:

Hours: 0800 - 1700 Pacific Time
Days: Monday - Friday
Tel: +1 510 337 6600
Email: CustomerServicesAPAC@vitecgroup.com

d) Email Technical Support is available for all Clear-Com branded products free of charge for the life of the product, or two years after a product has been classified as obsolete, whichever comes first.

e) Support for Distributor and Dealer Sales

i) Distributors and Dealers may utilize the Customer Service Centers once a system has been installed and commissioned. Clear-Com Systems and Applications Engineers will provide support to the Distributor from the pre-sales stage through to satisfactory installation for new system purchases. Customers will be encouraged to contact their Dealer or Distributor with their installation and technical support enquires rather than using the Customer Service Centers directly.

f) Support for Direct Sales

i) Customers may utilize the Customer Service Centers once a system has been installed and commissioned by Clear-Com Systems and Applications Engineers, or in the case of project installations, once the Project Team has completed the hand-over to the Support Centers.

RETURN MATERIAL AUTHORIZATION POLICY

- a) Authorizations: All products returned to Clear-Com or a Clear-Com Authorized Service Partner must be identified by a Return Material Authorization (RMA) number.
- b) The Customer will be provided with an RMA number upon contacting Clear-Com Sales Support as instructed below.
- c) The RMA number must be obtained from Clear-Com via phone or email prior to returning product to the Service Center. Product received by the Service Center without a proper RMA number is subject to return to the Customer at the Customer's expense.

- d) Damaged equipment will be repaired at the Customer's expense.
- e) Returns are subject to a 15% restocking fee.
- f) Advance Warranty Replacements (AWRs);
 - i) *During the first 30 days of the Standard Warranty Period:* Once the equipment fault has been verified by Clear-Com or its authorized representative, Clear-Com will ship a new replacement product. The Customer will be provided with an RMA number and be required to return the faulty equipment within 14 days of receipt of the replacement or will be invoiced for the list price of a new product.
 - ii) *During days 31-90 of the Standard Warranty Period:* Once the equipment fault has been verified by Clear-Com or its authorized representative, Clear-Com will ship a like-new, fully refurbished replacement product. The Customer will be provided with an RMA number and be required to return the faulty equipment within 14 days of receipt of the replacement or will be invoiced for the list price of a new product.
 - iii) To obtain an RMA number or request an AWR:
 - (1) North and South America, Asia-Pacific, and US Military:

Hours:	0800 - 1700 Pacific Time
Days:	Monday - Friday
Tel:	+1 510 337 6600
Email:	SalesSupportUS@vitecgroup.com
 - (2) Europe, the Middle East and Africa:

Hours:	0800 - 1700 GMT + 1
Days:	Monday - Friday
Tel:	+ 44 1223 815000
Email:	SalesSupportEMEA@vitecgroup.com
 - iv) Note: AWRs are not available for UHF WBS Analog wireless intercom systems. UHF WBS Analog wireless intercom systems out-of-box failures must be returned to Alameda for repair.
 - v) Note: Out-of-box failures returned after 90 days will be repaired and not replaced unless approved by Clear-Com Management.
 - vi) Note: AWRs are not available after 90 days of receipt of product unless an AWR Warranty Extension is purchased at the time of product purchase.

- vii) Note: Shipping charges, including duties, taxes, and insurance (optional), to Clear-Com's factory is the responsibility of the Customer. Shipping AWRs from Clear-Com is at Clear-Com's expense (normal ground or international economy delivery). Requests for expedited shipping (E.g. "Next-Day Air") and insurance are the responsibility of the Customer.

REPAIR POLICY

- a) Repair Authorizations: All products sent to Clear-Com or a Clear-Com Authorized Service Partner for repair must be identified by a Repair Authorization (RA) number (see above).
- b) The Customer will be provided with an RA number upon contacting Clear-Com Customer Services as instructed below.
- c) The RA number must be obtained from Clear-Com via phone or email prior to returning product to the Service Center. Product received by the Service Center without a proper RA number is subject to return to the Customer at the Customer's expense.
- d) Return for Repair
 - i) Customers are required to ship equipment at their own cost (including transportation, packing, transit, insurance, taxes and duties) to Clear-Com's designated location for repair.
 - (1) Clear-Com will pay for the equipment to be returned to the Customer when it is repaired under warranty.
 - (2) Shipping from Clear-Com is normal ground delivery or international economy. Requests for expedited shipping (E.g. "Next-Day Air") and insurance are the responsibility of the Customer.
 - ii) **Clear-Com does not provide temporary replacement equipment ("loaner") during the period the product is at the factory for repair.** Customers should consider a potential prolonged outage during the repair cycle, and if required for continuous operations purchase minimum spare equipment required or purchase an AWR Warranty Extension.
 - iii) No individual parts or subassemblies will be provided under warranty, and warranty repairs will be completed only by Clear-Com or its Authorized Service Partners.
 - iv) Customers requesting a non-warranty repair will be provided an estimate of the total repair cost prior to the return of the equipment. In the event that Clear-Com is unable to estimate

the cost of repair, the Customer may elect to return the product to the factory for an estimate. The Customer is responsible for shipping costs both to and from the factory in the event they choose not to accept the estimate.

v) The Customer must provide either a purchase order for the repair work, or will be required to make an advance payment (as a debit against the Dealer's line of credit, or credit card) prior to the repaired product being returned to the Customer.

vi) For requesting a Repair Authorization number:

(1) North and South America, Asia-Pacific, and US Military:

Hours: 0800 - 1700 Pacific Time
Days: Monday - Friday
Tel: +1 510 337 6600
Email: CustomerServicesUS@vitecgroup.com

(2) Europe, the Middle East and Africa:

Hours: 0800 - midnight Central European Time
Days: Monday - Friday
Tel: +49 40 853 999 700
Email: TechnicalSupportEMEA@vitecgroup.com

vii) Note: Clear-Com's Limited Warranty does not cover normal wear and tear. The Customer will be charged the full cost of the repair if their equipment has been tampered with by non-approved personnel, or has been subject to damage through electrical failure, liquid damage or mishandling. The Customer Service Center will provide the Customer with a cost estimate for any such repairs prior to undertaking the work.