

# **Mark bass**

**BASS at its BEST**

[www.markbass.it](http://www.markbass.it)

OWNER'S MANUAL

R500

# R 500

## OWNER'S MANUAL



### 1. INTRODUCTION

Congratulations on purchasing one of the world's best bass amplifiers! Markbass amps are built to the highest standards by a small team of skilled technicians in San Giovanni Teatino, Italy.

We have spent many years researching not only the highest-quality technologies for bass amp design and construction, but also the practical needs of the working bassist. The end result is a product that combines outstanding sound quality with intuitive features, attractive design and extreme reliability—all in one impossibly lightweight unit.

This amp will allow your instrument to speak in its natural voice, faithfully conveying your musical ideas to your audience with stunning clarity.

Your amplifier has passed rigorous product testing and should survive even the toughest of environments on the road and rehearsal halls.

Nonetheless, please treat it with care and you will be rewarded with many, many years of glorious, rich, powerful bass tone!

If the clarity and power of this amp inspire you to play better music, we will have succeeded in our mission. Good luck and enjoy your new best friend!

Sincerely, Markbass

## 1.1 A WORD FROM MARCO DE VIRGILIIS

When I began to develop the Markbass concept in Italy several years ago I had one objective in mind: to produce a top-quality bass amp that would meet the needs of professional bass players everywhere. I wanted my amps to be compact and lightweight, yet able to handle the low frequencies that today's four, five and six string passive and active basses are capable of producing. Thanks to modern technology and the availability of high-quality components like low-profile toroidal transformers, neodymium speakers and so on, I was able to accomplish this.

The Markbass amplifier circuitry is designed specifically not to color the sound of the bass but to faithfully reproduce the unique tonal qualities of whatever instrument is played through it. I have worked very closely with many high-profile professional bass players around the world to fine-tune the Markbass product line.

I am confident that the Markbass line of amps and cabinets is now ready to satisfy the needs of bass players all over the world.

Thanks for choosing Markbass; I hope you will find your new amp to be an inspiring upgrade to your sound!

We encourage you to use your Markbass gear in all kinds of musical situations—and please help us to continue developing our products by sending your comments to [info@markbass.it](mailto:info@markbass.it).

And above all, enjoy the music.

Marco De Virgiliis

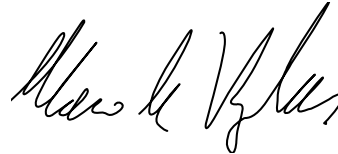

MARKBASS - ITALY

[www.markbass.it](http://www.markbass.it)



## 2. IMPORTANT SAFETY INSTRUCTIONS

- 1) Read these instructions;
- 2) Keep these instructions;
- 3) Heed all warnings;
- 4) Follow all instructions;
- 5) Do not use this apparatus near water;
- 6) Clean only with dry cloth;
- 7) Do not block any ventilation openings. Install in accordance with the manufacturer's instructions;
- 8) Do not install near any heat sources such as radiators, heat registers, stoves, or other apparatus (including amplifiers) that produce heat;
- 9) Do not defeat the safety purpose of the polarized or ground-type plug. A polarized plug has two blades with one wider than the other. A grounding type plug has two blades and a third grounding prong. The wide blade or the third prong are provided for your safety. If the provided plug does not fit into your outlet, consult an electrician for replacement of the obsolete outlet;
- 10) Protect the power cord from being walked on or pinched, particularly at plugs, convenience receptacles, and the point where they exit from the apparatus;
- 11) Only use attachments/accessories specified by the manufacturer;
- 12) Unplug this apparatus during lightning storms or when unused for long periods of time;
- 13) Refer all servicing to qualified service personnel. Servicing is required when the apparatus has been damaged in any way, such as when power-supply cord or plug is damaged, liquid has been spilled or objects have fallen into the apparatus, or when the apparatus has been exposed to rain or moisture, does not operate normally, or has been dropped;
- 14) "Warning: to reduce the risk of fire or electric shock, do not expose this apparatus to rain or moisture; and objects filled with liquids, such as vases, should not be placed on this apparatus";
- 15) The socket outlet shall be installed near the equipment and shall be easily accessible;
- 16) The power cord must be unplugged prior to servicing.

## 2. PRÉCAUTIONS D'EMPLOI

- 1) Lire ces instructions;
- 2) Conserver ces instructions;
- 3) Suivre tous les conseils d'utilisations;
- 4) Suivre toutes les instructions;
- 5) Ne pas utiliser cet appareil au bord de l'eau;
- 6) Nettoyer uniquement avec un chiffon humide;
- 7) Ne pas bloquer le système de ventilation. Installer conformément aux instructions du fabricant;
- 8) Ne pas installer l'appareil près d'une source de chaleur tel qu'un radiateur, un fourneau, ou bien un autre appareil qui produit de la chaleur;
- 9) Ne pas modifier le système de sécurité de la fiche polarisée ou de la fiche pour les prises de terre. Une fiche polarisée a deux broches, l'une étant plus distante de l'autre. Une fiche pour prise de terre a deux broches et une pointe pour la masse. La broche plus distante et la pointe pour la masse ont été installées pour votre sécurité. Si la fiche fournie ne rentre pas dans votre prise de courant consulter un électricien pour la substitution;
- 10) Protéger le cordon d'alimentation afin qu'il ne soit pas piétiné ou écrasé tout particulièrement au niveau des fiches, des prises de courant femelles, et des parties qui sortent de l'appareil;
- 11) Utiliser uniquement les accessoires recommandés par le fabricant;
- 12) Ne pas brancher l'appareil en cas d'orage accompagné d'éclairs. Le débrancher en cas de non utilisation prolongée;
- 13) S'adresser à un service assistance agréé si l'appareil a subi des dommages, si le cordon d'alimentation ou la fiche a été endommagé, si un liquide a été renversé sur l'appareil ou bien si un objet est tombé dans l'appareil, si ce dernier a été exposé à la pluie ou à l'humidité, s'il ne fonctionne pas correctement ou s'il est tombé;
- 14) "Avertissement: pour réduire le risque du feu ou de décharge électrique, n'exposez pas cet appareil à la pluie ou l'humidité et les objets remplis de liquides; tels que des vases, ne devraient pas être placés sur cet appareil";
- 15) La prise de courant doit être installée près de l'appareil et doit être facilement accessible;
- 16) La fiche principale doit être débranchée avant toute opération d'entretien.

## MORE INFORMATION

For warranty and service information, please contact your local Markbass distributor (contact information available at [www.markbass.it](http://www.markbass.it)). For more technical information, please visit us at [www.markbass.it](http://www.markbass.it) and fill out the form on the Contact Us page. We hope you enjoy your amp and use it to make great music!



"The Lightning Flash with arrowhead symbol within an equilateral triangle, is intended to alert the user to the presence of uninsulated "dangerous voltage" within the product enclosure that may be of sufficient magnitude to constitute a risk of shock to persons."



"The exclamation point within an equilateral triangle is intended to alert the user to the presence of important operating and maintenance (servicing) instructions in the literature accompanying the product."

### 3. R500 PRODUCT OVERVIEW

The Markbass R500 is a high-quality bass amplifier with a tube preamp and an analog power amp, which delivers 500W of power into a 4 ohm cabinet, or 300W into an 8 ohm cabinet.

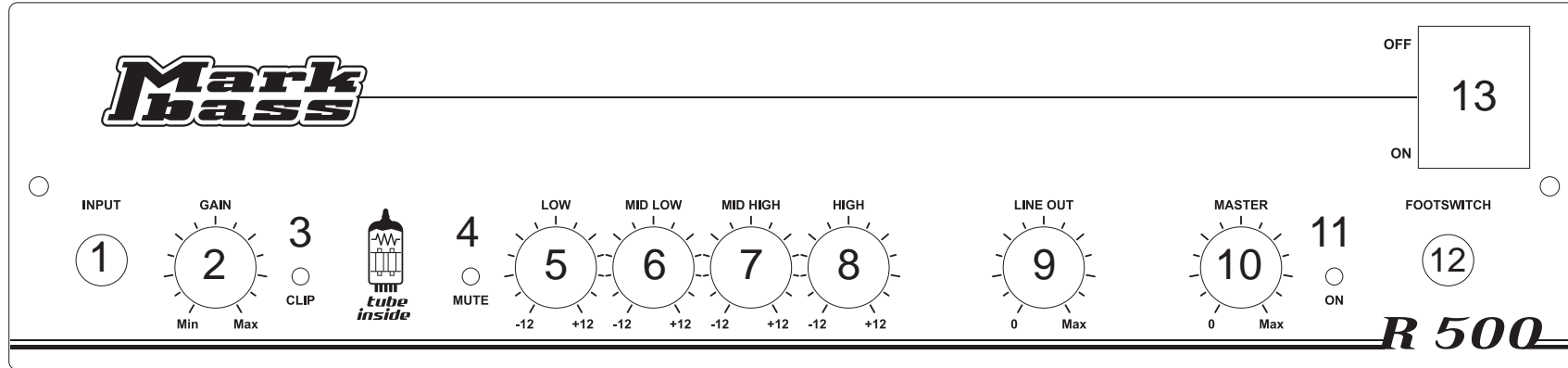

#### 3.1 R500 FRONT PANEL

##### INPUT

The input jack can be used for both passive and active basses.

##### GAIN and MASTER

There are two knobs on the front panel of the R500 that control the volume of your bass. The GAIN (2) control determines how much signal is passed through the preamp stage of the unit, which includes the preamp tube, the equalization circuits and the effects loop. The MASTER (10) volume regulates how much output comes out of the power amp into your cabinet. If playing through the amp causes the blue 'CLIP' (3) light to turn on at all, you should turn down the GAIN (2) if you want to avoid distortion.

When you first plug into the amp, start with the GAIN (2) and MASTER (10) controls set at their lowest levels, in other words turned all the way counter-clockwise. Then, turn your instrument's volume up to its full level and play as hard as you do in your most aggressive moments, and turn up the GAIN (2) control until the blue light starts illuminating. Next, back off on the GAIN (2) just enough so that the light stays off as you play. This method will result in the optimal gain setting for the bass you're playing. Different basses have different output levels, mostly depending on their pickups—and in the case of active basses, the instrument's onboard preamp and EQ settings.

Once you've set the GAIN (2) level, use your MASTER (10) knob to control the volume of your bass. If you wish to play with a distorted sound, turn up the GAIN (2) until you find the desired amount of distortion, then use the MASTER (10) to control your volume.

##### LINE OUT

This LINE OUT (9) knob controls the volume level of the rear XLR LINE OUT (21), which is connected to the mixing console in live or studio situations.

## EQUALIZATION

Markbass amps are designed to faithfully reproduce the natural sound of your bass. If you have a good instrument, very little equalization (EQ) if any should be required. Bass guitars produce a surprisingly wide range of frequencies from extremely low frequencies that are more felt than heard, to extremely high frequencies that pass through your cabinet's tweeter and are barely audible to the human ear. As you experiment with your EQ settings, you will notice that all the different frequency ranges play essential roles in making up your bass tone:

LOW frequencies constitute music's sonic foundation—they give power to your sound, physically resonating your listeners' bodies (and yours!), sometimes even causing people to move and dance!

LOW MIDs (MID LOW or Mid Frequency Low) make your bass sound loud, projecting the sound over long distances, filling the room.

HIGH MIDs (MID HIGH or Mid Frequency High) convey the pitch of the notes that you play. Clarity of this range ensures that the melodies in your bass lines are heard. If detail is missing in this range, your melodic contribution to the music will suffer.

HIGH frequencies carry the percussive content of your playing, the attack of your notes, the sound of your finger or pick passing over the string, fret noise, and in the case of slap bass, the 'tick' noise produced when the strings bounce off the frets.

If any one of these frequency ranges is neglected or poorly represented by your amp, you are not hearing an accurate representation of the sound that your bass is generating.

Since these amps have been designed to give you clear, detailed and musical sound at all frequencies, when the amp is set 'flat' with all EQ knobs at 12 o'clock you should hear a very true mirror of the sound of your bass.

However, the following circumstances will require you to use equalization:

1. The signal from your bass is lacking output level in one of the frequency ranges described above.
2. The room or venue you're playing in has poor acoustics and excites a certain frequency. For example, if you're playing on a hollow stage, certain low frequencies may sound disproportionately loud or out-of-control, and you may notice that every time you play a certain note, it sounds much louder than all the others. In these cases the offending frequency needs to be identified and reduced.
3. You're seeking to alter the basic sound of your instrument in order to achieve a particular musical effect.

Equalization should be treated as fine-tuning. Spend some time listening to your bass through the amp with all the EQ controls in the neutral (12 o'clock) position before you start changing the settings. You're likely to need little or no equalization!

However, if and when equalization is required, you will find this amp's EQ controls to be powerful.

The LOW (5) EQ control is set to a center frequency of 80 Hz. This means that it either boosts or cuts the volume of the frequencies around 80 Hz, to a maximum of 12 decibels.

The LOW-MID (MID LOW) (6) EQ control boosts or cuts the frequencies around 400 Hz, by as much as 12 decibels.

The HIGH-MID (MID HIGH) (7) EQ control boosts or cuts the frequencies around 800 Hz, by as much as 12 decibels.

The HIGH (8) EQ control boosts or cuts the frequencies around 3 kHz, by as much as 12 decibels.

### 3.2 R500 REAR PANEL

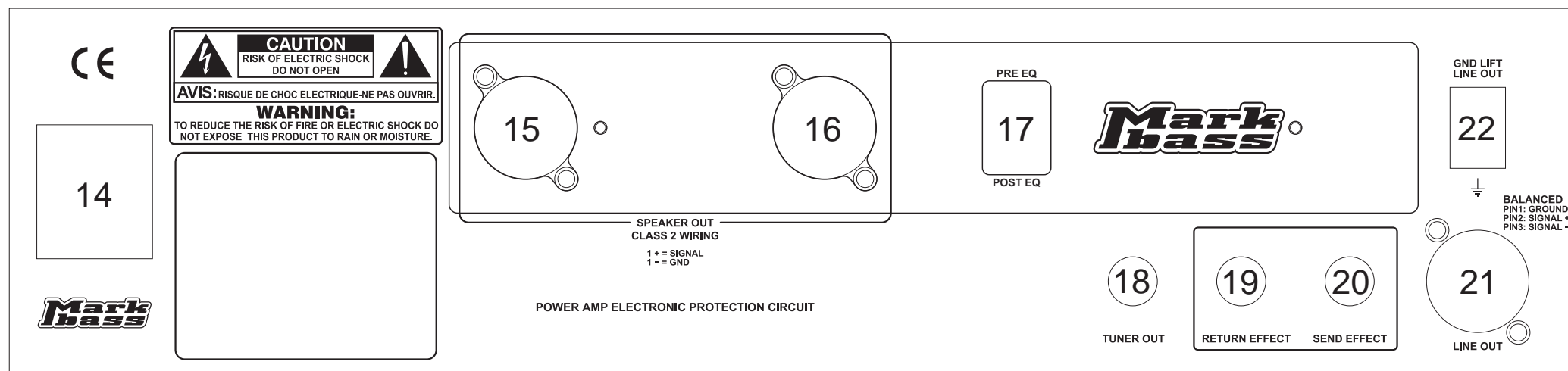

#### SPEAKER OUT

The R500 can be connected to one or two speaker cabinets using either 1/4" speaker cables (do not use instrument cables) or speakon speaker cables. The two high-quality Neutrik SPEAKON COMBO jacks (15,16) are designed to accept either of these connection types. The minimum load is 4 ohms. If you connect two cabinets, the impedance of each cab must be 8 ohms or higher. If you connect a 4 ohm cabinet, you cannot connect a second cabinet. The R500 delivers 300W of power into an 8 ohm cabinet, or 500W into a 4 ohm cabinet.

#### LINE OUT

The balanced XLR (21) output allows you to connect your amplifier directly to a mixing console (either in live situations or in a recording studio) without the need of a DI box. Simply connect a standard XLR cable from this output to the soundboard/mixing console, or a snake connected to the board/console. If the soundman/engineer needs more or less signal from you, simply turn the front panel LINE OUT (9) control up or down as necessary.

#### PRE EQ / POST EQ

This SWITCH (17) determines whether the signal that leaves the LINE OUT XLR (21) is affected by your amplifier's EQ settings or not. In most cases, you will find that sound engineers prefer to receive a pre-EQ signal. Note that the line out signal includes whatever effects you've connected through the effects loop.

#### GROUND LIFT

Occasionally when you're playing live and using the LINE OUT (21), the soundman will detect a hum from your amp's signal. This is almost always due to a grounding problem related to your power source; you will likely eliminate this hum simply by flipping the GROUND LIFT (22) switch.

#### TUNER OUT

The TUNER OUT (18) is an unbalanced signal that can be sent to a tuner, allowing you to tune as you play without passing your signal through pedals, which can degrade the quality of your signal. You can also use this output to send your signal on to another amp, or any kind of recording unit that doesn't require a balanced signal.

#### EFFECT SEND AND RETURN

If you use effect pedals or rack gear, you can route them through the SEND EFFECT (20) and RETURN EFFECT (19) jacks on the rear panel of the amp. The effects loop is wired in parallel—this means that if something happens to your effects chain (a battery dies or a cable gives out, for example) while you're playing, you will not lose your main signal. If desired, however, the effects loop can be easily modified by authorized service personnel to operate in series.

#### FOOTSWITCH

The R500's optional footswitch has one on/off switch. This is a mute control that interrupts the output signal from your amp, but allows it through to a tuner, should you have one plugged into the rear panel. This is handy if you need to tune discreetly during live performance. The blue LED (4) on the front panel illuminates when this switch is activated.



### 3.4 R500 TECHNICAL DETAILS

INPUTS		OTHER	
INPUT	impedance: 500 Kohm, max. voltage: 9 Vpp	HEIGHT	2 rack units (3.36 in. / 86 mm)
RETURN EFFECT	impedance: 33 Kohm, max. voltage: 12 Vpp	WIDTH	14.21 in. / 36.8 cm (19 in. / 48.3 cm with rack ears)
CONTROLS		DEPTH	11.89 in. / 30.2 cm
GAIN	-80 dB to +25 dB range	WEIGHT	8.16 lbs / 3.7 kg
LINE OUT	level control on front panel	OUTPUT POWER	300W RMS @ 8 ohms, 500W RMS @ 4 ohms
PRE/POST EQ (for line out)	switch on rear panel	POWER REQUIREMENT	100V; 120V; 230V; 240V 50/60Hz (Voltage is factory preset according to region of sale and can be modified by authorized Markbass service technicians)
GROUND LIFT	switch on rear panel		
MASTER VOLUME			
EQUALIZATION			
LOW	center frequency: 80 Hz; level: $\pm 12$ dB		
MID LOW	center frequency: 400 Hz; level: $\pm 12$ dB		
MID HIGH	center frequency: 800 Hz; level: $\pm 12$ dB		
HIGH	center frequency: 3 kHz; level: $\pm 12$ dB		
OUTPUTS		FUSE	
SEND EFFECTS	unbalanced, max. voltage 12 Vpp	230V	4A 250V T 5x20
TUNER OUT	unbalanced, max. voltage 2 Vpp	240V	4A 250V T 5x20
LINE OUT	balanced XLR, max. voltage 25 Vpp	120V	8A 250V T 5x20
SPEAKER OUT	speakon / 1/4" (x2)	100V	10A 250V T 5x20
FOOTSWITCH	mute		

### 3.5 R500 BLOCK DIAGRAM

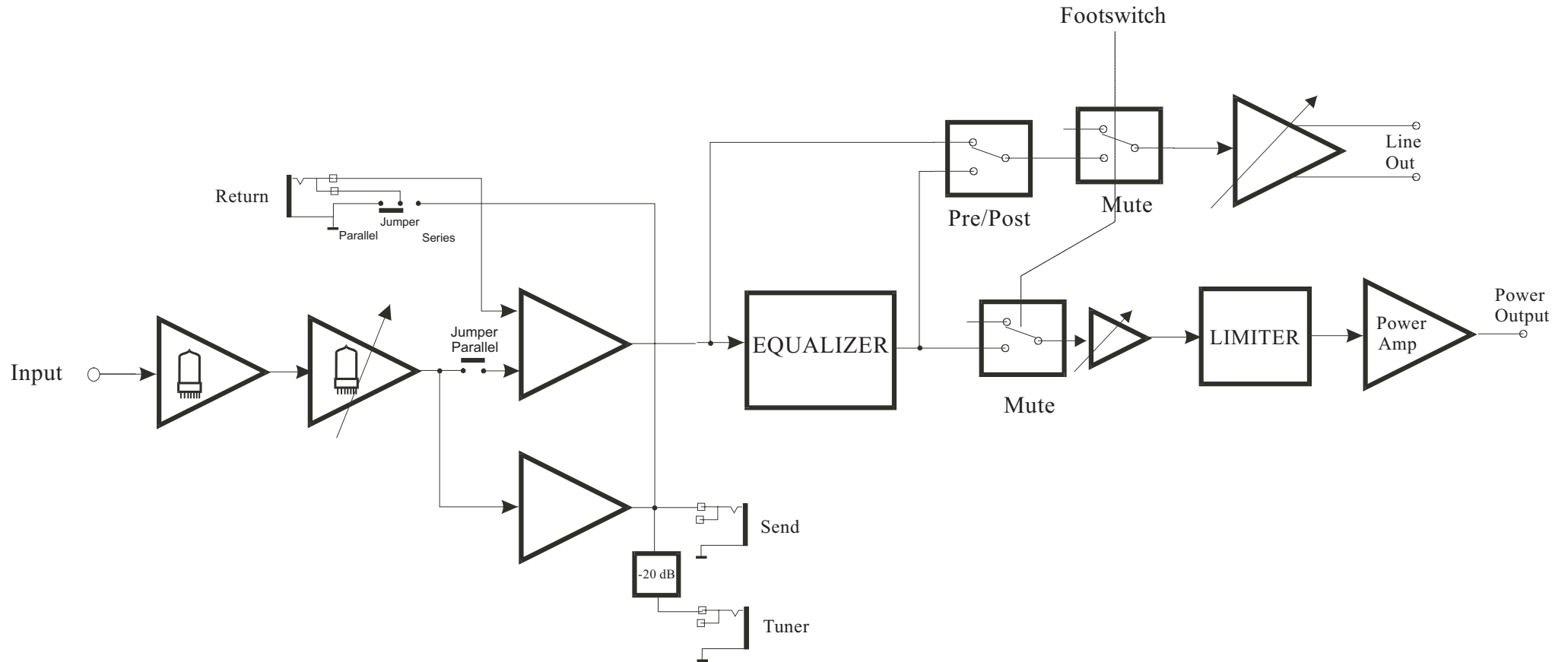

### 3.6 R500 EQ GRAPHS

LOW

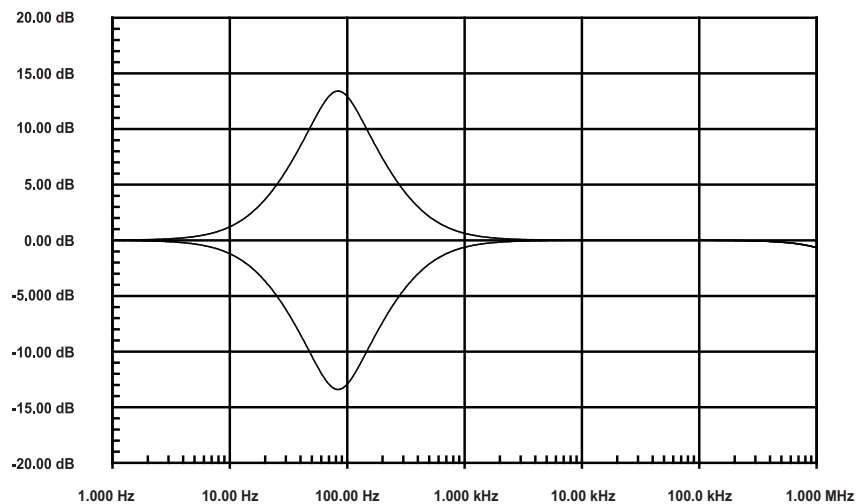

MID LOW

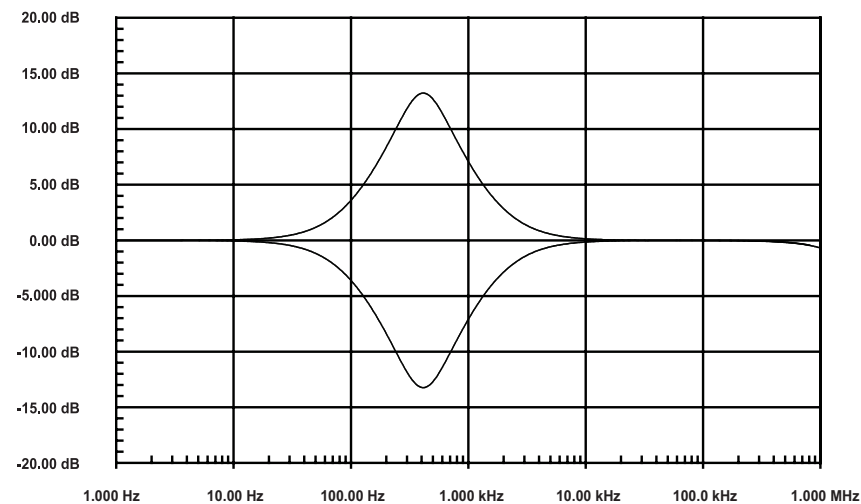

MID HIGH

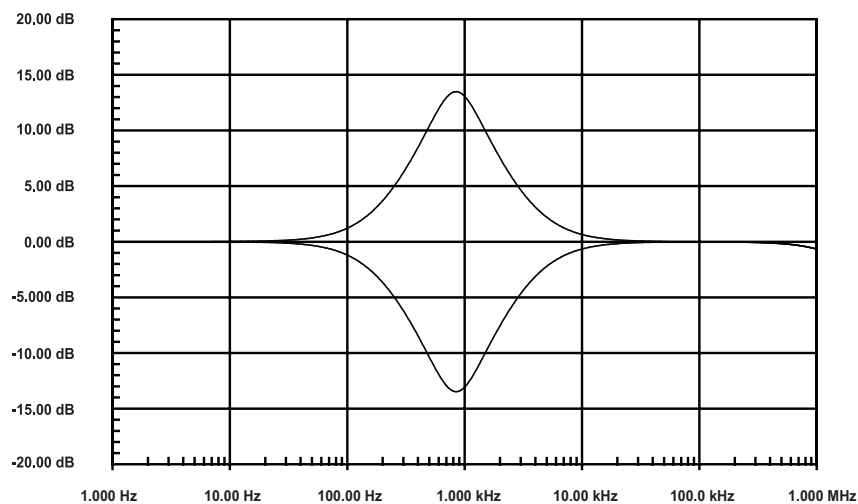

HIGH

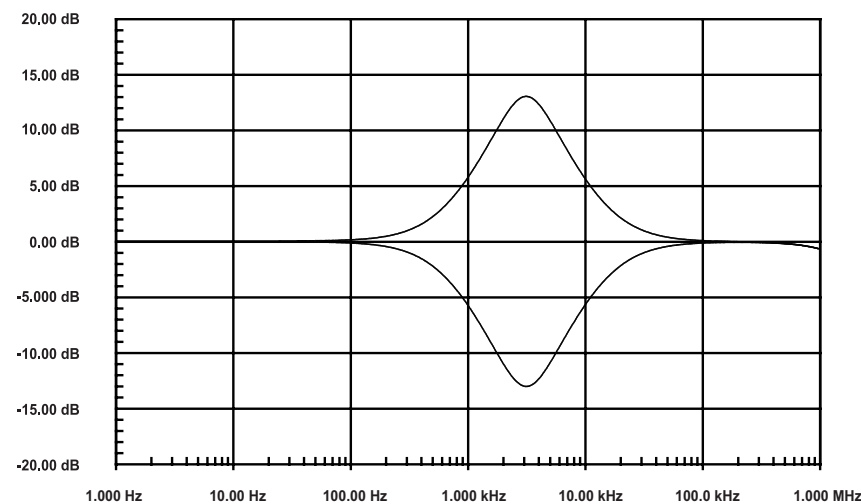

Product specifications are subject to change without notice

The logo for Markbass, featuring the brand name in a bold, italicized, sans-serif font with a white outline and a black drop shadow. The letters are closely spaced and have a slight slant.

**BASS** at its **BEST**

[www.markbass.it](http://www.markbass.it)