



## HEATING SYSTEMS

### COUNTERFLOW OIL MODELS

Takes Less Horizontal Space

#### Standard Features:

- Fan and limit control switch
- Breaker disconnect box
- Blower motor:
  - 200: 3/4 HP-7 Amp
  - 300: 3/4 HP-7 Amp
  - 400: 1 HP-9.2 Amp

\*Based on 80% efficiency

#### Siebring Warranty:

- 10 years on heat exchanger (prorated)
- 1 year on components (replacement of parts only)

#### Options:

- 2-stage fuel pump (21 ft. lift)
- Low temperature thermostat (30°)

Item #	Description	Price
22-2641	Siebring Counterflow Oil Fired Heater 203CFSM	Call for pricing
22-2642	Siebring Counterflow Oil Fired Heater 304CFSM	Call for pricing
22-2643	Siebring Counterflow Oil Fired Heater 404CFSM	Call for pricing

Shipped direct from factory. Freight to be added. Call for pricing.



### WASTE OIL HEATERS

Also available. Call for more info.

### ROYAL HEAT GAS MODEL

Gas Model (LP or Natural) in 240-360 Thousand BTU Oil Models Available

#### Standard Equipment:

- Jet/Vortex combustion design
- Easy-out burner service tray
- Draft diverter included
- Horizontally-directed air flow pattern
- Jets easily cleaned- no plugging
- Stainless steel baffling

Case	240	360
Width	27"	31"
Overall width	31"	35"
Length	27"	31"
Overall length	48"	54"
Height	48"	48"
Overall height	51"	51"
Weight	640 lbs.	780 lbs.

#### Siebring Warranty:

- 10 years on heat exchanger (prorated)
- 1 year on components (replacement of parts only)

Item #	Description	Price
22-2830	Royal 240 Gas Heater	Call for pricing
22-2835	Royal 360 Gas Heater	Call for pricing

Shipped direct from factory. Freight to be added. Call for pricing.



### CORRECT WAY TO VENT A GRAVITY VENTED GAS HEATER

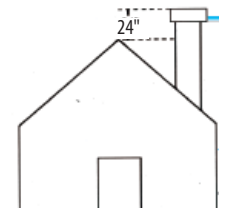
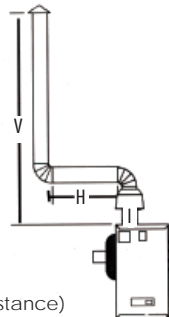
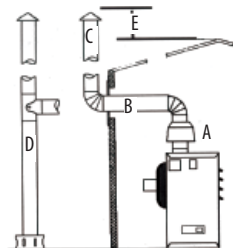

- A. Draft Diverter
- B. Horizontal Flue ( Must slope up at 1/4" per foot)
- C. Vertical Flue ( Must be at least twice as tall as the horizontal distance)
- D. Alternate stack design for free standing support
- E. Chimney should extend at least 2-4 feet above high point of roof
- "V"- Verticle Chimney Height ( "V" must be at least twice as long as "H"
- "H"- Horizontal Pipe (Must slope upwards from the furnace 1/4" per foot of horizontal distance.)
- "I"- Draft 0.02 to 0.03 inches of water column. Measure below diverter

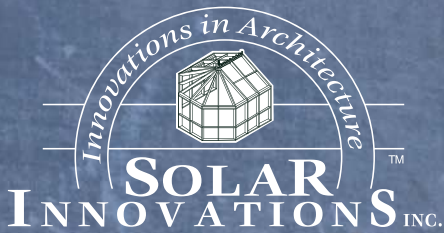

Commercial spaces designated with commercial greenhouses by Solar Innovations® allow for a truly unique shopping experience. Commercial greenhouses can extend far beyond the florist's shop to include grocery stores, convenience stores, libraries, and shopping centers, just to name a few. These extraordinary focal points allow for environmental growth and convenience for many businesses across the country.

Solar Innovations® commercial greenhouses allow our customers to improve their internal and external viewing abilities, thus improving overall safety at the greenhouse application. These thermally-enhanced structures provide a consistent growing environment, as well as comfort and versatility. Because of their structural integrity and overall development, Solar Innovations® greenhouses utilize energy as efficiently as any structure in the industry today.

## Working with **progressive vendors** to find **solutions** for our customers!



BIO-FUEL TECHNOLOGIES LLC ("BFT") is the exclusive United States Distributor for the BFT Chain Gate Boiler. Our system design incorporates the three components required for efficient combustion of solid fuel; they are: time, temperature and turbulence. The combination of over-fire air and the air passing through the fuel bed provides turbulence required for rapid and complete combustion of solid fuel. The Chain Gate Stoker design has a significant advantage over other systems. The system provides a large area of the chain grate that is conservatively designed to assure a complete combustion of solid fuel.

*What do you have to burn?*



Large wood chips w/turkey manure (ready for firing)



Touch Pad Control Panel



10,000,000 BTU Hot Water Boiler heating a greenhouse

## HEATER HANGER KITS

Each kit contains all items you will need to hang your heater.

Item #	Description	Price
22-3055	Double Leg Heater Hanger Hanging columns and bar, * truss braces, split tees and hardware. * Truss braces should be angled to gable end for proper fit.	\$200.74
22-3060	4-point Double Leg Heater Hanger Hanging columns and bar, * truss braces, split tees and hardware.	\$250.79

### Double Leg Heater Hanger Kit 2 Point mounting arrangement

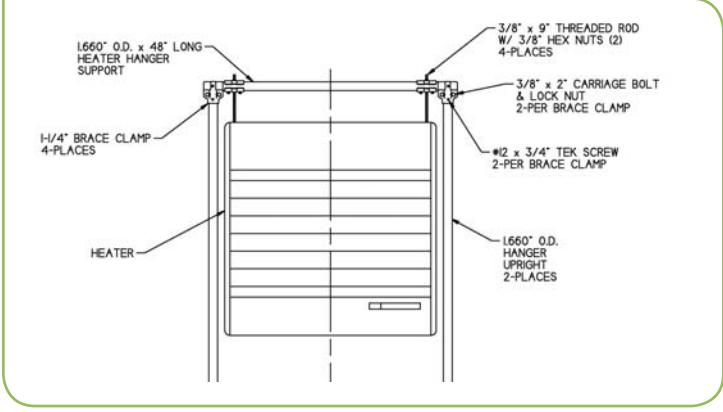

### Double Leg Heater Hanger Kit 4 Point mounting arrangement



## MATERIAL HANDLING SOLUTIONS



## GET ON THE **Fastrak**

- Complete system with individual components
- Reduces labor costs & increases productivity
- Economically priced for quick payback
- Carts adjust for seasonal crop changes
- Easily retrofits to existing structures
- American made & built to last

### FASTRAK SYSTEMS

All Fastrak Systems need to be priced out per job and a Fastrak Data Sheet needs to be submitted.

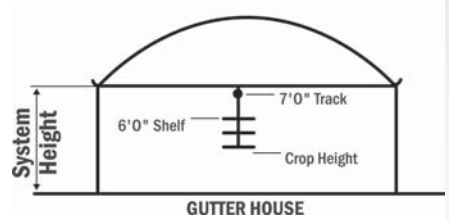
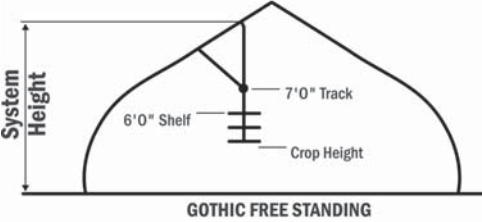
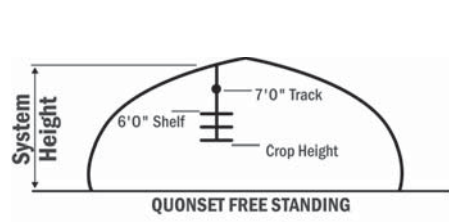



### Your Extended Forecast:

**93% Efficiency with 100% Chance of Savings.**

### HIGH-EFFICIENCY CONDENSING GAS-FIRED SEPARATED COMBUSTION UNIT HEATERS

**IN COMPARISON, THERE'S NO COMPARISON.**

Modine's Effinity93 (model PTC) condensing unit heater line is the most efficient gas-fired, condensing unit heater in North America.

With six models available — from 135,000 to 310,000 BTU/hr — all operating at 93% efficiency, the Effinity93 will dramatically lower energy costs through decreased fuel consumption.



### Propeller Unit Heater Model PTC General Performance Data

Model PTC Sizes						
	135	155	180	215	260	310
Btu/Hr Input	135,000	155,000	180,000	215,000	260,000	310,000
Btu/Hr Output	125,550	144,150	167,400	199,950	241,800	288,300
CFM @ 70°F	2160	2510	3020	3865	4585	5400
Outlet Velocity (FPM)	719	835	676	699	831	765
Air Temp Rise (°F)	54	53	51	48	49	49
Max Mounting Height (ft.)	14	17	15	17	20	19
Heat Throw (ft.) @ Max Mtg Ht	51	59	53	60	70	67
Motor Type	PSC	PSC	PSC	PSC	PSC	PSC
Motor HP	1/3	1/3	1/3	1/2	3/4	3/4
Motor RPM	1075	1075	1075	1075	1125	1125

### GAS-FIRED, POWER-EXHAUSTED, LOW PROFILE (Also available in Separated-Combustion)

Propeller	Model Number					
	HD 30	HD 45	HD 60	HD 75	HD 100	HD 125
Btu/Hr Input	30,000	45,000	60,000	75,000	100,000	125,000
Btu/Hr Output	24,000	36,000	48,000	60,000	80,000	100,000
Vent Dia. (in.)*	3 or 5	3 or 5	3 or 5	3 or 5	4 or 6	4 or 6
CFM @ 70°F	505	720	990	1,160	1,490	1,980
Air Temp Rise (°F)	44	46	45	48	50	47
Max Mounting Height (ft.)**	10	10	12	14	12	16
Heat Throw (ft.)**	25	27	36	38	42	56
Motor HP	1/25	1/15	1/12	1/12	1/12	1/8



- 80% Thermal Efficiency
- Horizontal or vertical venting
- Field convertible to propane
- Low profile casing
- Direct spark ignition
- 100% Shut-off with continuous retry
- Mounting brackets supplied
- Commercial or residential applications

\*Vent size varies depending upon application.

\*\*At 65°F ambient temperature and unit fired at full-rated input. Mounting height is measured from floor to bottom of unit.

## GAS-FIRED, POWER-EXHAUSTED HIGH-EFFICIENCY II™ UNIT HEATERS

(Also available in Separated-Combustion)

- 80% Thermal efficiency
- Rotating power exhaust
- Horizontal or vertical venting
- Field-convertible to propane
- Field-adjustable level hanging
- Intermittent pilot ignition, 100% shut-off with continuous retry



### Important Note:

Do not locate ANY gas-fired unit in the areas where chlorinated, halogenated, or acid vapors are present in the atmosphere. We strongly recommend each unit be controlled by its own thermostat. See page 59

Propeller		Model Number						
		PDP 150	PDP 175	PDP 200	PDP 250	PDP 300	PDP 350	PDP 400
Btu/Hr Input	For power exhausted models rated 30,000 to 125,000 Btu/hr, please see the previous page.	150,000	175,000	200,000	250,000	300,000	350,000	400,000
Btu/Hr Output		120,000	140,000	160,000	200,000	240,000	280,000	320,000
Vent Dia (In.)		5	5	5	6	6	6	6
CFM @ 70°F		2180	2550	2870	3700	4460	4870	5440
Air Temp Rise (°F)		51	51	52	50	50	53	54
Max Mounting Height (ft)		16	17	15	19	21	20	19
Heat Throw (ft)*		55	59	51	67	74	70	69
Motor HP		1/8	1/6	1/6	1/3	1/2	3/4	3/4

Many sizes in stock. Call for more information.

\* At 65° ambient temperature and unit fired at full-rated input. Mounting height is measured from floor to bottom of unit.

## HORIZONTAL POWER VENTED UNIT HEATER

Introducing the new horizontal power vented, PTP unit heater line. The PTP delivers 80% thermal efficiency in a small business-friendly package. This unit features a stainless steel tubular heat exchanger as standard on all units with a 10-year heat exchanger warranty that provides customers with a peace of mind. The PTP is available in 7 models sizes - 150,000 to 400,000 BTU/hr.



## STEAM AND HOT WATER UNIT HEATERS



Proven for greenhouse, industrial and commercial application. Has adjustable horizontal air deflector blades. Vertical deflector blades are optionally available for complete directional control. Horizontal units available with top/bottom inlet/outlet piping connections.



Verticals are designed for overhead and out-of-the-way mounting. Four deflector types are available for various air distribution patterns... from high, jet-like beam to low, broad, gentle cone. V models have copper tubes, VN models have cupro nickel tubes.



## INDOOR AIR SOLUTIONS

### Warning:

Installation instructions must be strictly followed for all Modine units to avoid damage.



Shown with optional diffuser

**BEAMFLICKER-E SYSTEM**

Photoperiod Control Day-Length Extension

Replaces traditional incandescent — Up to 30' x 80' coverage

A single, centrally-located, stationary fixture providing enough photoperiod control light for an entire greenhouse. Cost efficient, saves up to 80% in energy costs versus traditional incandescent lighting.

**Electrical Specifications**

Input Voltage: 120, 240

**Cost Comparison**

Beamflicker™	Incandescent
400 or 600 watts	7000 - 10,000 watts
Red	Far Red
24,000 Hrs Life	1000 Hrs Life
Easy to install	Cost to install
Virtually maintenance free	-
Cost to run 10¢ / Day	\$3.20 / Day

Item #	Wattage	at 120 Volts	at 240 Volts	Price
93-2400	400 watt	3.8 amps	1.7 amps	\$920.80
93-2600	600 watt	5.5 amps	2.6 amps	1,064.12



**E-BALLAST**

Higher light output compared to traditional magnetic ballasts.

More Lumens — Completely Silent  
 Fast Start Up — Maintenance Free

PARsource "E" Ballast - is factory tested for 12 hours to ensure reliability. The "E" is microprocessor-controlled. It automatically adjusts for Halide or Sodium, guaranteeing proper performance with every bulb. RF shielded output cord, automatic safety cut-off circuitry, lightweight - under 20 pounds.

**T5 FLUORESCENT**  
 High Lumen, Low Profile

The multifaceted T5 Reflector System puts out more than double the light energy of normal fluorescent lighting systems. T5's stay cool to the touch so they can be used in low clearance rack systems. Available in several light spectrums for specific plant growth needs.

- High output tubes
- Extremely energy efficient
- Includes all bulbs
- Fully assembled
- Lightweight aluminum housing
- Hangs easily, 4-tube weighs under 10 lbs.
- Low profile
- 10,000 hour bulb life
- Rapid start, no noise
- 2-year warranty

**Great for:**  
 Germination Chambers  
 Under Bench Lighting  
 Tissue Culture  
 Growing Racks

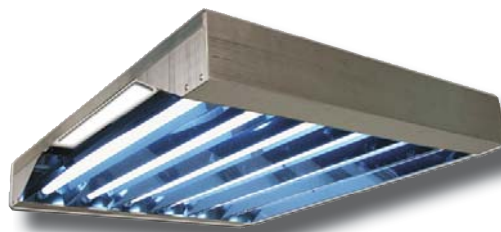

T5 Specs	4 Tube	6 Tube	8 Tube	12 Tube
Lumen Output	up to 20,000 total	up to 30,000 total	up to 40,000 total	up to 60,000 total
Amperage	1.98 amps	2.85 amps	3.78 amps	5.40 amps

T5 Sizes	4 Tube	6 Tube	8 Tube	12 Tube
Size	3"H x 13.5"W x 46"L	3"H x 19.5"W x 46"L	3"H x 26"W x 46"L	3"H x 39"W x 47"L
Weight	21.5 lbs	26.5 lbs	31.5 lbs	52 lbs

# SUPPLEMENTAL LIGHTING

## HSE DAYLIGHT FIXTURES

The fixture gives practically the same light spectrum as daylight, which makes this fixture perfect for use in places without natural daylight, such as growing rooms at research stations or in industrial buildings. For urban farming the fixture utilizes an energy efficient electronic ballast which ensures a long life span. The fixture therefore fully complies with the sustainability demands placed on equipment today.



HSE Daylight

Contact Our Office for Pricing

## HSE 600 & 1000 WATT FIXTURES

With the HSE 600W & 1000W fixtures, P.L. Light Systems is proud to utilize electronic ballast technologies with increased efficiency and prolonged life. The HSE series of fixtures were developed in anticipation of the need for higher light levels within greenhouses while improving energy conservation.

Contact Our Office for Pricing



HSE NXT2



HSE 600W Lamp

## METAL HALIDE FIXTURES

Standard Features on all Metal Halide Fixtures include:

- Fitted tempered glass reflector covering
- Heat dissipating extruded aluminum body with ventilation openings
- Compact body reduces shading effect
- Available in 120, 208, 240, 277, 347, and 480 volts
- C.S.A. and U.L. approved Metal Halide Fixtures

Contact Our Office for Pricing



PL3000 Fixtures Available in: High Pressure Sodium Lamp & Metal Halide Fixture

## HIGH PRESSURE SODIUM FIXTURES PL2000 & PL3000

High Pressure Sodium Fixtures are actually available in 250W, 400W, 400W SUPER, 600W, 1000W.

Standard Features on all HPS Fixtures include:

- Improved collar design for easy installation and removal of all reflectors
- Heat dissipating extruded aluminum body with ventilation openings
- Available in 120, 208, 240, 277, 347, and 480 volts
- Compact body reduces shading effect
- C.S.A. and U.L. approved

Item #	Description	1-3	4-up
40-1015	High Pressure Sodium Fixture 400W 115V	\$282.40	\$256.14
40-1076	Phillips 400W HPS Bulb	25.45	22.78

## HORTI LED HSE R/B

The HSE HortiLED R/B Production Module is designed specifically for crops grown within multi-layer cultivation systems. Growers can utilize this LED Lighting system to accurately promote positive growth for their plants. Through the use of high powered wide angle LED's the HSE HortiLED's can be installed closer to the crops resulting in more growing surfaces with increased uniformity. Available in 120cm (4') and 150cm (5') lengths.

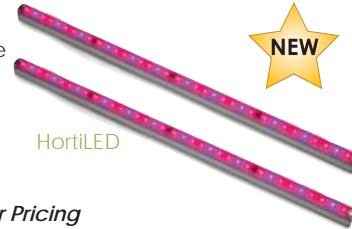

HortiLED

Contact Our Office for Pricing

## MORE LIGHT, LESS ENERGY - HS2000

With the HS2000, P.L. Light Systems has made a great move forward in terms of efficiency, quality and reliability. The HS2000 is one of the most up-to-date, all-in-one fixtures on the market today.

- 600 Watt - 208/240/277 as well as 480 Volt system

Contact Our Office for Pricing



HS2000 Lamp

## REMOTE FIXTURES (special order)

Standard Features on all Remote Fixtures include:

- Receptacle and plug for the 15' cord between the fixture and lamp
- Durable steel body with ventilation openings for maximum cooling
- Available in 120, 208, 240, 277, 347 and 480 volts
- Standard mounting hardware for lamp and reflector
- Standard 120V or 240V power cord
- One year warranty on the light bulb
- Two year warranty on all fixtures
- C.S.A. and U.L. approved

Remote Fixtures



Contact our office for pricing



Alpha



Zeta



Beta



Superwide



Deep



Midi



Wide



Delta



Maxima

Reflectors

### G-STAT4

Upgrade from thermostats and cut your expenses with the G-STAT4. Using a simple, centralized control eliminates competition between your heating and cooling equipment, saving you money and energy.



Requires a contactor panel.

**Features:**

- 4 stages of heating or cooling or a combination of both
- 2 temperature setpoint periods (day and night)
- Solar-shielded temperature sensor with 75' of shielded cable
- LCD screen displays current temperature, mode and output status
- Keypad provides easy operation • Fahrenheit or Celsius scale
- NEMA 4 enclosure, 9" x 5.5" x 3" (228 x 140 x 76 mm)

**Benefits:**

- Easy to install and operate
- Improves crop quality by providing more accurate temperature monitoring
- Reduces fuel costs by centralizing temperature sensor
- Prevents heating and cooling from running simultaneously
- Simplifies control and maintenance
- Increases productivity
- Requires 1amp @ 115 VAC / Shipping Wt. 7 lb

**No. 24-3600 \$459.53**

Contactor Panel Options			
24-3605	1 SPDT 1HP 120V M-5500	\$138.01	
24-3607	2 SPDT 1HP 120V M-5505	163.07	
24-3609	3 SPDT 1HP 120V M-5510	190.63	
24-3611	4 SPDT 1HP 120V M-5515	218.12	

**Day / Night settings help SAVE on your heating**

### ENVIROSTEP™

There's no better combination of power and value than the EnviroSTEP. This integrated control offer precise control of all aspects of your climate: temperature, humidity, light level, CO2 and watering based on VPD.



**Features:**

- Single zone control
- 3 set point temperature periods: day, night and DIF
- 12 relay outputs with manual override switches
- 2 analog outputs (0 to 10VDC) to control variable-speed equipment
- Records the status of all inputs and outputs
- Alarm notification: temperature, RH and power failure
- Largest display in the industry; has menu-driven choices & graphic functions
- Keypad for easy operation
- This is an approved energy saving device

**Includes:**

- Solar-guarded aspirated temperature and humidity sensor and 100' of cable
- Solar-shielded outdoor temperature sensor with 25' of cable

**No. M-4840\* \$1,995.04**

### STEP UP CONTROL™

STEP Up to improved control and increased profits. This control is an approved energy saving device.



**Features:**

- Single zone control
- 6 stages: 2 stages of heating and 4 stages of cooling
- 3 set point temperature periods: day, night and DIF; auto adjusts based on sunrise and sunset
- Timed override switches in addition to the manual override toggle switches
- Large menu-driven screen displays current temperature, time, date, grow weeks, equipment status
- Records and stores temperature data
- Modulates vents and curtains
- Logs and graphs data
- Alarm output

**Includes:**

- Solar-guarded aspirated temperature sensor and 100' of cable

Item #	Description	Price
M-5000*	STEP UP Control Requires either M-5001 or M5640	\$612.01
M-5001*	STEP UP Override Relay Panel	495.01
M-5640*	STEP UP Contactor Panel	Call for price

### STEP 50 A™

Growers choose this control because it is rugged and easy to operate —just turn the day and night knob to the desired temperature and the STEP 50A will do the rest.



**Features:**

- Single zone control
- 5 stages: 2 stages of heating and 3 stages of cooling
- Day and night temperature settings — simply turn the two knobs to indicate the desired temperatures
- Controls most heating and cooling equipment
- Energy savings through programmable lockout of stages
- Modulating output voltage for proportional steam and hot water valves
- Equipment comes on gradually after a power failure
- Color-coded manual override toggle switches
- Replaceable 10 amp DPDT load relays, can operate a wide variety of equipment — these relays reduce the cost of your contactor panel

**Includes:**

- Solar-guarded aspirated temperature sensor and 100' of cable

**No. M-4010\* \$1,170.02**

*\*Items not stocked. Prices FOB factory*



## POWER PULL ENERGY CURTAIN

Save 30-40% on energy costs. It's an efficient way to cool, control light and heat loss. This truss-to-truss system does not stress the greenhouse and has minimal maintenance.

- Positive drive rack and pinion system — no cable to re-tension
- Fabric glides between stationary stainless steel lines
- Slow-moving system optimizes management of cold air spill
- Built-in safety limits protect your system
- Durable fabric
- Small bundle size ensures minimal shade
- Positive seal when closed
- Flexible design, easy installation for new projects or retrofitting



Pleasant View Garden in NH, dual curtain system



### 3 RPM VC 2000 VENT DRIVE

- 1/5 Horsepower – TEFC, Continuous Duty
- 115 Volt - 60 Hz - 2.5 amp
- 1600 RPM; Total gear reduction 550:1; final output 3 RPM
- Output torque 1500 in. lb. / 169 Nm VC 100A Vent Drive
- Lifts up to 325' of 4' polycarbonate roof ridge vent or 400' of 4' polycarbonate side vent
- Thermal overload protection – automatic reset
- Quick reversing
- Adjustable torque limit switch assembly
- Output gear reducer: worm gear with tapered roller bearing on output shaft immersed in synthetic grease
- Dual output shaft

Item #	Description	Price
M-1550*	VC - 2000 / ILS 1 3/8" O.D. Shaft 3 RPM Drive Unit (no control)	\$1,210.02
M-1555*	VC - 2000 / ILS 1 3/8" O.D. Shaft 3 RPM Drive Unit (no control)	1,210.02
M-1001*	LST Lead Control	240.00
M-1003*	2R Follower Control	195.00

Prices FOB factory



### VC 100A VENT DRIVE

- 1/20 Horsepower TENV, Continuous Duty
- 15 Volt - 60 Hz - .68 amp
- 1600 RPM motor; Total gear reduction 1900:1; final output .84 RPM
- Output torque 500 in. lb. / 56 Nm
- Lifts up to 75' of 4' polycarbonate roof ridge vent or 125' of 4' polycarbonate side vent
- Thermal overload protection – automatic reset
- Quick reversing
- Adjustable torque limit switch assembly
- Output gear reducer: worm gear with tapered roller bearing on output shaft immersed in synthetic grease
- Dual output shaft

Item #	Description	Price
M-1090*	VC - 100A / ILS 1 3/8" O.D. Shaft Drive Unit (no control)	\$970.02
M-1092*	VC - 100A / ILS 1 3/8" O.D. Shaft Drive Unit (no control)	970.02
M-1001*	LST Lead Control	240.00
M-1003*	2R Follower Control	195.00

Prices FOB factory

## ALUMINUM RACK AND PINION



Call for pricing

- Zinc pinion gear with shoulders to bear the weight and extend the life
- Wide housing allows for movement in the vents prevents binding
- Freedom from corrosion: stainless clevis pins, cotter pins, set screws, cast sash brackets and tough Nylatron bearings
- Easy alignment: racks work even when the vent is not perfectly square
- Arm and housing are manufactured from aluminum alloy for strength and freedom from corrosion they have precision-cut teeth

## STEEL RACK AND PINION



Call for pricing

- Rack arms are a heavy galvanized steel u-channel cut
- Corrosion-proof pinion gear
- Pinion houses are galvanized steel
- Rust-free plastic-free rollers and self-lubricating bronze journal bearings

## VERSATILE VENT



- Wadsworth's most flexible and capable vent control. It can be used with any type of environmental control or as a stand-alone unit if you don't have a temperature control.

### Features:

- Manual override toggle switches
  - Includes a transformer and relays
- Does not include Aspirator

No. M-1465\* \$610.01

## VERSATILE VENT COMPLETE PACKAGE



If you don't have a temperature control, the Versatile Vent is available with a temperature sensor.

- It will open your vent or rollup in three increments: 25%, 50% and 100%.

### Features:

- Manual override toggle switches
- Displays temperature, vents position, and has an alarm output

### Includes:

- Aspirated temperature

No. M-1460\* \$690.01

\*Items not stocked. Prices FOB factory

# MICRO GROW

## GREENHOUSE SYSTEMS, INC.



Offers a wide variety of Environmental controls!  
Contact you Griffin sales rep for a complete listing.

### GROWMASTER GROWCOM

#### Single Zone Advanced Computer Control

Enjoy the same precision control of our Growmaster Procom a single zone environment with our Growcom system. We have packed the most common environmental control equipment in use in a single zone control system. The Growcom can also be used with our Growlink Windows based software. A Zone Temperature Sensor, as well as a Solar Sensor, come with the Growcom. The Growcom features four separate daily operation modes including DIF. Low voltage 24 VAC operation.



#### Growmaster Growcom Features

- Use as a stand alone system, or with your PC with our Growlink system
- Cooling, air circulation, ventilation, and shading equipment
- All heating equipment including hot water valves and boilers
- Optional fogging and dehumidify with humidity sensor available
- Full alarm functions and sensor history record and display for 30 seconds

Item #	Price
24-5000	\$1,595.00

### GROWMASTER GROWMATE

#### For Smaller Installations

The Growmate offers many of the very same features as the Growmate Plus. It is designed for smaller greenhouses, but offers exacting computer-based control of cooling, heating, and air circulation equipment. DIF settings, separate day and night temperature control, and manual override switches are standard features. Low voltage 24 VAC operation.



#### Growmaster Growmate Features

- Accurate microprocessor control
- Large digital display and convenient program switches
- Three cooling stages, two heating stages
- Air circulation output for HAF fans
- DIF operations are standard

Item #	Price
24-5024	\$995.00

### GROWMASTER PROCOM

#### Precision Control, Multiple Zone Capability, Easy Operation

Years of research and development have resulted in the Growmaster Procom being the system of choice for hundreds of commercial and research greenhouse growing operations throughout the world. From a single zone of operation, to complex multiple zone applications, the Procom delivers time and time again. The Procom features "state of the art" control algorithms based on internal conditions as modes including DIF. Manual override switches are located on the front panel for ease of use. A large informative display constantly updates as to all greenhouse conditions and equipment operations. Enclosed in a NEMA 12, lockable non-metallic enclosure with a clear cover, the Procom is easy to use and easy to install on new and existing projects. Low voltage 24 VAC operation.



#### Growmaster Procom Features

- Energy saving features for commercial growers
- Precise automation for research applications
- Sensor history record and display for 30 days
- State of the art software and equipment operations
- Irrigation and misting control based on time, VPD, or soil moisture
- Accurate microprocessor control of your entire environment
- Fully expandable with additional sensor input and output modules
- Add your PC to your Procom system for endless possibilities

Item #	Price
24-5005	\$1,995.00

### GROWMASTER GROWMATE PLUS

#### Affordable, Accurate, Control

If you think that computer based greenhouse control systems are expensive, the Growmate line of products will enlighten you. An affordable choice for many growing operations, the Growmate Plus puts the power of a microprocessor based control system in your hands at a price that anyone can afford. All temperature settings can be adjusted independently for day and night heating and cooling, as well as DIF settings. A large and informative display assists in programming, while providing a constant readout of all sensors. Manual override switches for all outputs are conveniently located on the front panel. Growmate Plus includes a temperature sensor and photocell. An optional humidity sensor is available for accurate and true dehumidify functions. Low voltage 24 VAC operations.



#### Growmaster Procom Features

- Accurate microprocessor control
- Large digital display and convenient program switches
- Five cooling stages, two heating stages
- Air circulation output for HAF fans
- DIF operations are standard
- Optional humidity sensor available

Item #	Price
24-5025	\$1,295.00

All Items on this page are not stocked.  
Prices are FOB Factory.

## DRAMM/MICROFAN MECHANICAL THERMOSTATS

Dramm / Microfan mechanical thermostats are designed with rough environments in mind. These high quality thermostats are perfect for any situation where harsh conditions may damage less durable equipment. Protected in durable PVC housing, these thermostats offer stainless steel coil sensors and accuracy to 1° C.

### Features:

- Durable PVC housing
- Unlimited accuracy
- Non-corrosive construction
- Sealed wiring strain relief
- Single-stage or two-stage



T42-SV Double Stage Thermostat

T41-SV Single Stage Thermostat

Item #	Description	Price
24-2300	T41-SV Single Stage Thermostat	\$63.55
24-2305	T42-SV Double Stage Thermostat	111.72

## GREENHOUSE THERMOSTATS

(weather-proof Line Voltage)

- 16 Full load amp rating at 120 Volt
- 30° to 110°F



Portable Single Stage Thermostat (prewired)



Double Stage Thermostat

Single Stage Thermostat

Item #	Vendor #	Description	Price
24-6001	KJ16110	Single Stage Thermostat	\$33.70
24-6002	KT16110	Double Stage Thermostat	89.68
24-6010	KP16110	Portable (prewired) Single Stage Thermostat (comes with 8' cord)	60.47

## PLUG IN TIMER

The Intermatic Heavy Duty Grounded Timer plugs right into a standard wall outlet. 24 hour grounded plug in timer.

Easy to use - plug the timer into a wall outlet - no wiring involved - then plug your lights, pump, heater, AC or whatever (120V) into the timer.

Three on/off settings (EXTRA CLIPS FOR MORE THAN TWO AVAILABLE IN ACCESSORIES). Rated at 15FLA resistive and 1,875 watts tungsten and inductive. Will work with one 1000 watt grow light or 12 FLA motor or 12 amp AC/heater.

No. 24-6025 \$26.53





Twenty Years Experience Designing Heating Systems for All Types of Growing Environments

- Hot water boilers
- Heat exchangers
- EPDM rubber tube bench-top heating
- EPDM rubber tube in-ground heating
- Twin-fin aluminum tube heating
- Multi-fin aluminum tube heating

## GREENHOUSE HEATING SYSTEMS



## HOT WATER HEATING SYSTEMS

Delta T hot water heating systems utilize the physics of heat to efficiently heat plants. Putting the heat under the plant allows the heat source to react faster to temperature changes at the plant level. Heating from below offers a more constant temperature, better plant quality, and lowers heating costs.

### Delta Tubes

Delta Tube heating systems are designed with the grower in mind. Key benefits include durability, low maintenance, low volume, and fast response.



### Delta Tube™ SD

This system provides the best growing environment for propagators, plug producers and general growing. Healthy, more uniform plants plus at least 20% fuel savings make this system the grower's choice. Uses Delta T quality synthetic tubing that will not break down under ultraviolet rays.



### Delta Tube™ LD

Large diameter EPDM rubber tube in-ground heating system is ideal for larger ranges. The system excels in the nursery industry and is very economical for starter houses because it can save you 20% or more over conventional forced air heating. Uses DeltaT high quality synthetic tubing that will not break down under ultraviolet rays.



### Delta Tube™ HD

The Delta Tube HD is a high density polyethylene floor heating system that is an excellent choice for heating warehouses, retail areas, potting areas, and greenhouses. It installs easily. And because the tubing is installed directly into the concrete floor, it doesn't get in the way. It is great for areas where run-off is a concern. Special manifolds are concealed in a 2' x 3' box in the floor. No tubing is left exposed. We also supply PEX tubing with oxygen barrier.



### Delta-Fin™ TF 1 & 2

Heats the greenhouse from below the bench, allowing for maximum temperature control and accelerated plant growth. Proven effective by many of the largest plug growers in the country. The reduced BTU's per foot and added material result in even heat being transmitted to plants. In addition, Delta-Fin TF 1 & 2 offers low water volume, high efficiency, aluminum construction, no rusting, and long life.



### Delta-Fin™ Multi Fin

The grower's choice for uniform convection heating. It is constructed of aluminum to dissipate heat quickly, resulting in energy savings. The external surface of 100 linear feet of Delta-Fin is approximately the same as 844 feet of 2" pipe to produce the same amount of heat as it would take 100 linear feet of 2" Delta-Fin. Its high BTU output means you need fewer units.

## WEB600 MONITORING SYSTEM

Provides flexible web-based remote monitoring at an affordable price. Keep track of critical temperatures and other conditions and be notified immediately when current values exceed the normal range. Completely standalone and easy to use, the Web600 can be used for monitoring cold food storage, medical cold storage, and other temperature sensitive areas like computer rooms and data centers. In addition to temperature monitoring, the Web600 can also read values from humidity sensors, air quality sensors, water leak detection sensors and much more.

- Alarm e-mail / text messages
- Up to eight people can be contacted
- Web programming
- Connect up to six external sensors



Item #	Description	Price
24-3165	WEB600	\$393.58
24-3170	External Battery Backup Module	78.26

## SENSAPHONE™

### Security Monitoring System

- Phone line needed for operation
- Continually monitors major environmental conditions
- Provides instant, verbal communication
- Lets you listen in to "live" sounds in your house
- Keeps working, even if there's a power failure
- Automatically dials up to 4 numbers, 32 digits
- A snap to install

The Sensaphone system allows you to establish two-way communication and direct security monitoring of your property, even when there's no one there.

It calls to tell you there's a problem and reports on:

- Power failure
- Temperature changes

### Detection Options Available:

- Fire and smoke
- Leaks or flooding
- Intruders...and more



Sensaphone™

Item #	Vendor #	Description	Price
24-3145	FGD 400	Sensaphone Model #400	\$428.93
24-3130	FGD 0100	Remote Temperature Sensor	21.60
24-3135	FGD 0067	Surge Suppressor w/ modem/FAX suppression	26.92
60FGD0101	FGD 0101	Weatherproof Temperature Sensor	31.52

## THERMALARM III

Thermalarm III is a temperature sensitive instrument containing an ambient temperature-indicating hand and two adjustable side hands for limiting the temperature range. When properly installed it will trigger a 6 to 12-volt alarm system when the temperature reaches a predetermined high or low setting.

- Hermetically sealed contacts
- Improved corrosion resistance
- Easily adjusted set hands
- Quicker response to temperature changes



Thermalarm III

Item #	Description	Price
24-2125	ThermAlarm III	\$62.79

## TEMP° ALERT®

Temp° Alert® will automatically ring a bell in your home or activate a greenhouse alarm system such as the Sensaphone® when the temperature in your greenhouse drops below or rises above your preset temperature limits.



Temp° Alert®

No. 24-4125      \$67.24



**GREENHOUSE SHADE CLOTH**

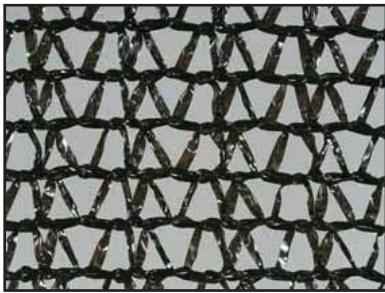

**GREENHOUSE SHADE CLOTH - BLACK 50% & 70%**

Provides shade in greenhouses and nurseries to flowers, vegetables and trees. Our quality knitted greenhouse shade cloth provides crop protection for UV and heat sensitive plants. The material is lightweight and has dramatically more strength. The tough lockstitch knitted construction resists rips, tears and fraying. Suitable to spread above greenhouse tops. Variety of widths available for custom cut lengths for quick delivery to you.

Widths available: 12', 20', 26' and 32'. We will custom cut to the length you need. In-stock for immediate delivery. \*\$25 cutting charge on orders under \$100.

Item #	Description	Per Linear ft.		
		1 - 49	50 - 99	100 +
81-810050	26 ft wide 50% knitted	\$4.82	\$4.33	\$3.85



**CUSTOM MADE SHADE CLOTH - 30-80% AVAILABLE**

Shade cloth can be custom ordered in to your specifications! Wide range of shade percentages available depending on your need. Grommets can be added to any order. Contact our office for details and to place your order. Please note that custom shade orders are non-refundable. Allow 4 weeks for delivery. F.O.B. factory on all orders.

\*\$25 service charge on orders under \$75.

**NYLON CABLE TIES**



- 11" non-releasable nylon cable ties
- U.V. treated
- Use with drip irrigation
- Use for shade cloth application

Item #	Price
30-2825	\$10.21



Use these durable clips for securing shade cloths, plastics, and fabrics.

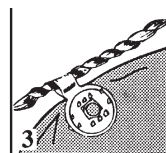

Secure materials by pressing Clip together.

**Green.tek**

The ultimate gripper-fastener for almost any netting, fabric or film!

- Use it and re-use it over and over



Item #	Description	Price
30-3025	CLIP-ITS	\$ 0.27

Item #	Description	Price
30-3034	Double S hook	\$ 0.24
30-3035	Shark Bite gripper-fastener	\$ 0.53



## KOOL-RAY CLASSIC LIQUID SHADING

KOOL RAY is back by popular demand in its "classic" Ezy-Off Formula. KOOL RAY CLASSIC may be its new name but its formula is the original and reliable KOOL RAY Ezy-Off.

KOOL RAY CLASSIC is specifically designed to lower inside greenhouse temperatures during the warmer spring and summer growing seasons. During the course of the year, CLASSIC's environmentally friendly ingredients will slowly wear off (weather permitting) allowing for increased light levels as the daylight decreases. CLASSIC works best when spray applied.

Item #	Description	Size	1-3	4-up
16-3160	Kool-Ray Classic White	1 gal.	\$30.37	\$27.33
16-3162	Kool-Ray Classic White	5 gal.	122.04	109.84
16-3164	Kool-Ray Classic Green	1 gal.	34.20	30.78
16-3166	Kool-Ray Classic Green	5 gal.	137.87	124.08
16-3150	X-tra Stick Binder	1 qt.	11.47	
16-3155	X-tra Stick Binder	1 gal.	39.99	

### Bedding Putty

Item #	Description	1-9	10-up
16-2055	Puttylastic Cartridges	\$10.55	\$9.49



X-tra Stick Binder

A 1:8 dilution will cover 1575 sq. ft. with a 30% reduction of light.

**ReduSol Xtra-** ReduSol Xtra has been especially developed for applications where the coat of white-wash applied to the greenhouse must last for a whole season. ReduSol Xtra provides an attractive white, even shading coat which can be easily removed using ReduClean at the end of the season.

- Optimal shading effect
- Outstanding weather resistance
- Easy to apply
- Removable with ReduClean

**ReduHeat** transmits a high percentage of PAR-light and greatly reflects near infrared light.

### ReduHeat

- A favorable shift towards more PAR light and less heat
- Very easy to remove with ReduClean
- A high red to far-red ratio of transmitted light for a stronger crop
- Highly water resistant

**ReduClean-** ReduClean products have been specially developed for the easy removal of ReduSol Xtra. ReduClean is economical to use and has a negligible corrosive effect when diluted according to directions. ReduClean removes ReduSol Xtra from glass, polycarbonate, and plastic film.

**ReduClean on glass, acrylic and polycarbonate-** Allow the product to act for approximately 10 minutes and then remove ReduSol Xtra with water. First, wet the surfaces thoroughly with water, allow to soak. Shading coats on glass surfaces can also be removed by the rain.

**ReduClean on plastic film-** After waiting about 5-10 minutes for the ReduClean to work, the ReduSol Xtra can be removed with water. First, wet the surfaces thoroughly with water, allow to soak, and then rinse with plenty of water.

**IMPORTANT-** (ReduClean on plastic film only)

- Do not let the diluted ReduClean dry on the applied surfaces.
- Always rinse off with water. A rain shower will not be effective.

Mixture Ratio	ReduSolXtra (gal)	Water (gal)	Shading % dry	Shading % wet
1:2	1.5	2.9	82	61
1:2.5	1.2	3.3	78	56
1:4	0.9	3.7	72	47
1:5	0.7	3.9	67	41
1:6.5	0.6	4.1	58	35
1:9.5	0.45	4.3	44	25
1:14	0.3	4.5	23	12

Item #	Description	Price
16-3230	15 L ReduSol Xtra White Shading Compound	\$127.21
16-3240	15 L ReduHeat	358.71
16-3285	25 L ReduClean Glass Shade Remover	281.88

See page 62 for Shade Cloth



## ReduSol Xtra ReduHeat ReduClean





# Hydroponics

**Griffin is a full line supplier of all your hydroponic needs.**

