

# Comfort Digisystem User Manual

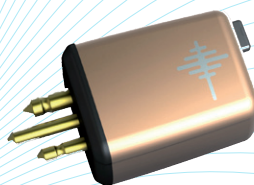

## Comfort Digisystem Receiver DT10



English



**Comfort Audio**  
HEAR THE FUTURE

# User Manual

<b>Table of Contents</b>	<b>Page</b>
Introduction Comfort Digisystem	3
Presentation of the Receiver DT10	3
Overview - Receiver DT10	4
Check the hearing instrument's input	5
Getting started	7
Acoustic indication, sound signals	8
Modes in the Receiver DT10	8
Output for user with different input types and programs in the hearing instrument	9
Pairing	12
Trouble shooting	14
Service and warranty	15
Technical data	15
Important safety instructions	16

## Introduction to the Comfort Digisystem

Thank you for choosing Comfort Digisystem. Our products are easy to use and give you crystal clear sound.

Before using the product, please read this manual carefully.

The Comfort Digisystem products feature SecureStream Technology – a unique, patented digital technology allowing eavesdrop-secure radio transfer in real time.

### Comfort Digisystem Receiver DT10 — the world's first digital mini receiver

The Comfort Digisystem Receiver DT10 is a digital mini receiver that you can easily connect to any hearing aid with a standard three-pin Europlug audio shoe.

The receiver weighs 1,5 gram and is powered by the hearing instrument's battery. To minimize energy consumption, the mini receiver is equipped with an optional auto-sleep feature.

Together with existing microphones and receivers in the Comfort Digisystem assortment, the Receiver DT10 provides clear speech perception.

The Receiver DT10 is the world's first mini receiver, taking full advantage of digital technology in enabling outstanding sound reproduction.

The optional professional tool Programmer DT05 can be used to configure the Receiver DT10.

The Programmer DT05 also makes it easy to test the Receiver DT10 with or without a hearing instrument.

## Overview - Receiver DT10

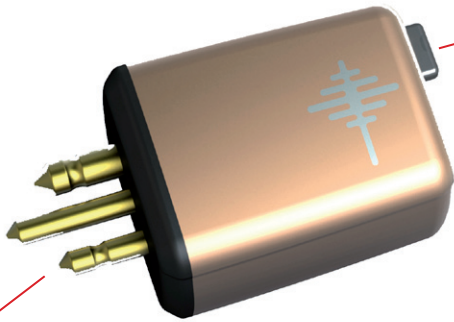

### **Europlug**

For connecting to the audio shoe on a hearing instrument or to the socket on the Programmer DT05.

### **Push-button**

For toggling between different listening modes and activating pairing mode.

## Check the hearing instrument's input

To be able to use the Receiver DT10, check if — and how — the hearing instrument supports the use of a mini receiver:

**1.** The hearing instrument must be equipped with an **audio shoe with a powered Europlug socket** made for mini receiver use. This connects the Receiver DT10 to the hearing instrument and also supplies the DT10 with power from the hearing instrument's battery. The received audio signal will then be transferred from the Receiver DT10 to the hearing instrument through the audio shoe.

**2a.** If the hearing instrument is equipped with a **Programmable DAI input (DPAI)**, programming of the hearing instrument might be necessary (check with audiologist or hearing instrument manufacturer). In this case the push-button on the Receiver DT10 cannot switch between the R and R+M modes. This is instead done by using different listening programs in the hearing instrument.

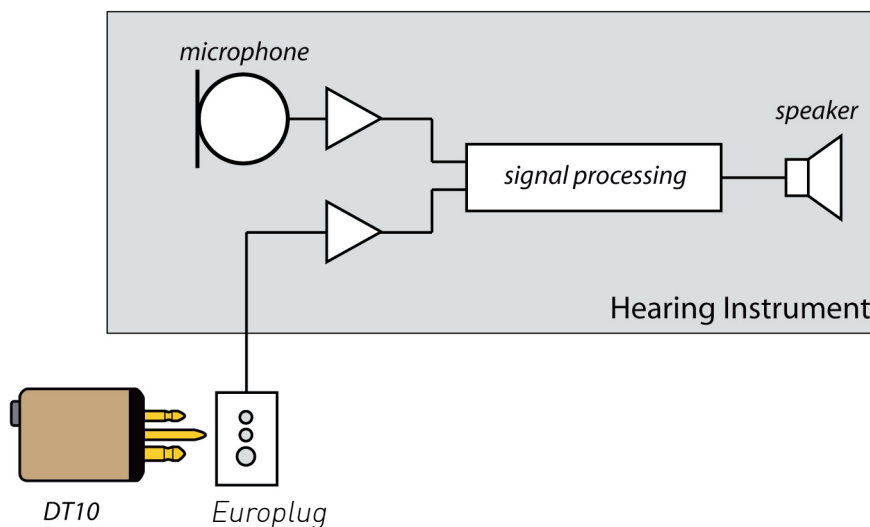

**TIP!** The volume of the Receiver DT10's R and R+M mode can be set individually by using the Programmer DT05. This makes it possible to use the push-button as a simple volume control in combination with a hearing instrument with Programmable DAI input (DPAI).

**2b.** If the hearing instrument is equipped with a **DAI input** (check with audiologist or hearing instrument manufacturer), no programming of the hearing instrument is necessary. The Receiver DT10 works with the Microphone (M) listening program on your hearing instrument. By setting up the Receiver DT10 with the Programmer DT05, the push-button on the Receiver DT10 can be used to select the listening mode: Radio only (R mode) or Radio + Hearing instrument microphone (R+M mode).

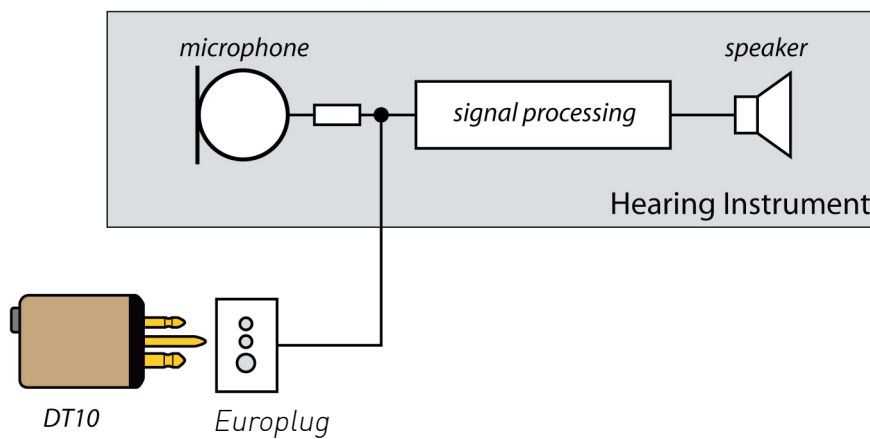

## Getting started

Connect the Receiver DT10 to the audio shoe on the hearing instrument. Check that the audio shoe is connected to the hearing instrument according to the manufacturer's instructions.

Make sure that the Receiver DT10 is fitted in the correct manner and push the Euro-plug completely into the socket of the audio shoe.

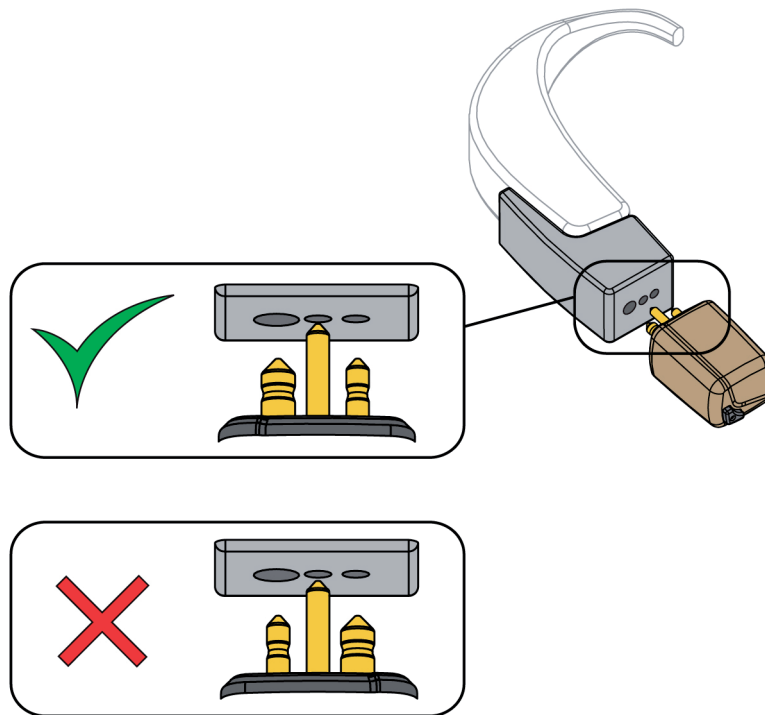





The Receiver DT10 is powered by the hearing instrument's battery. Make sure that the battery is fresh. If you are unsure, replace the battery.

The Receiver DT10 will start automatically when it's connected to the hearing instrument. Briefly press the push-button on the Receiver DT10 to turn it on or off again.

## Acoustic indication, sound signals

The following is a description of the acoustic indications (sound signals). The sound signals consist of various combinations of two different tones: one high pitch tone (1000 Hz) and one low pitch tone (500 Hz), and two different tone lengths.

Action:	Sound signal:	Indicate this:
Button pressed briefly	Short high pitch	 Selecting mode or turning on
Button pressed briefly	Short high pitch x 2 + long low pitch	 Turning off
Button pressed 2 sec.	Short low pitch + short high pitch	 Pairing mode
Pairing	Short high pitch x 2	 Successful pairing
Pairing	Long high pitch + long low pitch	 Pairing failed

## Listening modes in the Receiver DT10

The available listening modes in the Receiver DT10 can be setup in different configurations:

<b>R</b>	Default setting
<b>R+M</b>	Setup with Programmer DT05 is necessary
<b>R and R+M</b>	Setup with Programmer DT05 is necessary

The Programmer DT05 is used to configure and enable or disable different listening modes in the Receiver DT10. The push-button on the Receiver DT10 is used to toggle between the activated listening modes. It is also possible to disable the push-button completely.



## Output for user with different input types and programs in the hearing instrument

Different hearing instrument electrical input types and available programs in the hearing instrument will result in different output for the user. Output for the user is shown in the white sections of the charts below.

### Receiver DT10 with R mode enabled (default setting)

The chart below shows the output (what the user can hear) when Receiver DT10 listening mode R is enabled in combination with different input types and programs in the HI.

When pressing the push button on the Receiver DT10, the listening mode is shifted in the following sequence:

	Receiver DT10 push-button	
	Off	R mode
<b>Hearing instrument:</b>		
<b>DAI input</b>	Off	Radio only
<b>Programmable DAI input</b> DAI + M program	Off	Radio + HI microphone
<b>Programmable DAI input</b> DAI program only	Off	Radio only

### Receiver DT10 with R+M mode enabled and R mode disabled

The chart below shows the output (what the user can hear) when Receiver DT10 listening mode R+M is enabled, in combination with different input types and programs in the HI.

When pressing the push-button on the Receiver DT10, the listening mode is shifted in the following sequence:

	Receiver DT10 push-button	
	Off	R+M mode
<b>Hearing instrument:</b>		
<b>DAI input</b>	Off	Radio + HI microphone
<b>Programmable DAI input</b> DAI + M program	Off	Radio + HI microphone
<b>Programmable DAI input</b> DAI program only	Off	Radio only

## Receiver DT10 with both R and R+M modes enabled

The chart below shows the output (what the user can hear) when Receiver DT10 listening modes R and R+M both are enabled, in combination with different input types and programs in the HI.

When pressing the push-button on the Receiver DT10, the listening mode is shifted in the following sequence:

Hearing instrument:	Receiver DT10 push-button		
	Off	R mode	R+M mode
DAI input	Off	Radio only	Radio + HI microphone
Programmable DAI input DAI + M program	Off	Radio + HI microphone *	Radio + HI microphone *
Programmable DAI input DAI program only	Off	Radio only *	Radio only *

\* When using this setup in combination with Programmable DAI input (DPAI), the level of the two modes (R+M and R) can be programmed individually to serve as a volume control.

### **Note! Difference in volume can occur**

When using a hearing aid with Programmable DAI input (DPAI) and having both R and R+M modes in the Receiver DT10 enabled there can be a difference in volume between the R and R+M modes even if the Receiver DT10 has been programmed with identical output levels for the two modes. The reason for this difference is that the output level in the Receiver DT10 is affected by the input impedance of the hearing instrument.

The difference in output level can vary between different hearing instruments - usually the output level will be slightly higher in the R+M mode. An adjustment might be done with the Programmer DT05 in order to meet the users requirements.

## Pairing

The Receiver DT10 can receive but not transmit pairing information. To pair the Receiver DT10 with your Comfort Digisystem transmitter the Receiver DT10 must be connected either to your hearing instrument or to the Programmer DT05.



Press the push-button on the Receiver DT10 for 2 seconds to activate pairing mode.

When pairing mode is activated, you receive an acoustic indication: 



Send the pairing information within 15 seconds.

To interrupt pairing mode, briefly press the push-button.





### **Example 1: Pairing a Receiver DT10 into an existing Comfort Digisystem consisting of one Conference Microphone DC20 and one Receiver DH10:**

1. Connect the Receiver DT10 to the hearing instrument's audio shoe according to the instructions.
2. Initiate pairing mode in the DT10 by pressing the push-buttons for 2 seconds. Acoustic indication: 
3. Start the Conference Microphone DC20.
4. Rapidly press the pairing button on the DC20 twice. The display on the DC20 responds with the text Sending info.
5. The Receiver DT10 confirms successful pairing with an acoustic indication: 

### **Example 2: Make a new eavesdrop secure configuration with one Microphone DM80 and two hearing instruments with Receiver DT10s:**

1. Connect the Receiver DT10s to the hearing instrument's audio shoes according to the instructions.
2. Activate pairing mode in the two DT10's by pressing the push-buttons for 2 seconds. Acoustic indication: 
3. Start the Microphone DM80 and open the menu. Select *Communication/Pairing/New code key* and answer Yes to the question of whether you want to create a new code key and transmit it.
4. The Receiver DT10s confirm successful pairing with an acoustic indication: 

**Example 3: Make a new eavesdrop secure configuration with one Microphone DM80 and two Receiver DT10s using the Programmer DT05:**

1. Put one of the Receiver DT10s into the Programmer DT05.
2. Start the Programmer DT05 and connect headphones or a neck loop to be able to listen.
3. Activate pairing mode for the DT10 by pressing the push-button for 2 seconds.  
In the headphones/neckloop you receive an acoustic indication: 
4. Start the Microphone DM80 and open the menu. Select *Communication/Pairing/New code key* and answer *Yes* to the question of whether you want to create a new code key and transmit it.
5. The Receiver DT10 confirms successful pairing with an acoustic indication: 
6. Remove the paired DT10 and connect the other DT10 into the Programmer DT05.
7. Activate pairing mode on the DT10 by pressing the push-button for 2 seconds.  
In the headphones/neckloop you receive an acoustic indication: 
8. Open the menu on the DM80 and select *Communication/Pairing/Send info*.
9. The Receiver DT10 confirms successful pairing with an acoustic indication: 

## Trouble shooting

### The receiver does not start

1. Check that the correct listening program is selected on the hearing instrument.
2. Make sure the Receiver DT10 is correctly connected to the hearing instrument's audio shoe. Also check the connection between the audio shoe and the hearing instrument.
3. Make sure all connecting surfaces are clean.
4. Check/replace the hearing instrument's battery.
5. Remember to press the push-button briefly to switch the DT10 on.

### Poor speech intelligibility

The distance between the transmitter and the receiver may be too long. The range is around 15 meters.

The distance between the microphone and the talking person may also be too long; move the microphone closer to the talking person.

Try changing the channel/environment.

### Poor range and interference

In some environments, such as in buildings with a lot of concrete, iron or sheer metal structures, the range may be reduced.

There may also be electronic equipment nearby causing interference. Change the channel.

### No sound

Check that the transmitter and the receiver are set to the same channel.

### Loud hissing noise

Check that the Comfort Digisystem units you are using are paired together. If *Auto sleep* is enabled, the Receiver DT10 goes into sleep mode if there is no radio signal. But if another radio signal (with the same frequency you are using) is present, the Receiver DT10 might start again automatically. This could cause a loud hissing noise and that's why *Auto sleep* should be used with caution.

## Service and warranty

Comfort Audio AB accords a limited warranty for two years as of the date of delivery. This covers all defects of manufacture and materials. For accessories the warranty period is 90 days as of the date of delivery. Local agreements or regulations may exist.

Defects caused by careless handling or intervention inside the product or its accessories are not covered by the warranty.

It is perfectly normal that the battery's capacity decreases gradually. Battery lifetime depends on how the product is used. Contact your point of purchase when it is time to change the battery.

## Technical data

Radio transmission:	SST - SecureStream Technology
Frequency range:	F1 operates in 850-872 MHz
Range:	Approx. 15 m
Dimensions:	9,7 x 11,2 x 21,3 mm
Weight:	1,5 g



## Important safety instructions — read before using your product

- 1) Read these instructions.
- 2) Keep these instructions.
- 3) Heed all warnings.
- 4) Follow all instructions.
- 5) Do not use this apparatus near water.
- 6) Clean only with dry cloth.
- 7) Do not use near any heat sources such as radiators heat registers stoves, or other apparatus (including amplifiers) that produce heat.
- 8) Do not defeat the safety purpose of the polarized or grounding plug. A polarized plug has two blades with one wider than the other. A grounding plug has two blades and a third grounding prong. The wide blade or the third prong is provided for your safety. If the provided plug does not fit your electrical outlet, consult an electrician for replacement of the incorrect outlet — (only when using polarized plug).
- 9) Protect the power cord from being walked on or pinched particularly at plugs convenience receptacles. and the point where they exit from the apparatus.
- 10) Only use attachments/accessories specified by Comfort Audio AB.
- 11) Unplug this apparatus during lightning storms or when unused for long periods of time.
- 12) Refer all servicing to qualified service personnel. Servicing is required when the apparatus has been damaged in any way (such as if a liquid has been spilled on the apparatus, the apparatus has been subject to impact by another object or dropped or the apparatus has been exposed to rain or moisture) or does not operate normally.
- 13) Start listening at a low volume.



- 14) Too high a volume can seriously damage your hearing.
- 15) Don't disassemble the product.
- 16) Should the product break open because of damage, service should only be done by qualified service personnel.
- 17) Never use a transmitter or receiver set to a non-permitted frequency. Check with the frequency regulatory agency in the country where the equipment is to be used.
- 18) The product contains sensitive electronic equipment and must be handled carefully.
- 19) Never charge product in closed, unaired spaces such as handbags, cases or other closed storage bags.
- 20) Only use batteries and power supply specified by Comfort Audio AB.
- 21) You must not change the battery yourself; please contact your point of purchase.
- 22) **CAUTION!** Danger of explosion if battery is incorrectly replaced.
- 23) The product must not be exposed to excessive heat such as sunshine, open flames or the like.
- 24) Products include radio transmitters. Do not use products where the use of electronic equipment is not permitted, such as on airplanes.
- 25) The necklace should not be used if there is a risk of getting stuck, e.g. in a machine or other objects.
- 26) Keep small parts out of reach of children and animals. Choking hazard if swallowed.
- 26) Do not leave the product unloaded for too long, the battery could get damaged.
- 27) Do not keep the product connected to the charger if it is not used for a longer period.

*Subject to change*







## **Manufactured by:**

### **Comfort Audio AB**

Box154, SE-301 05 Halmstad, Sweden  
Tfn +46 35 260 16 00 Fax +46 35 260 16 50  
info@comfortaudio.com www.comfortaudio.com