

Starlight D1363D

User Manual Version #2: Camera with ICON Menu

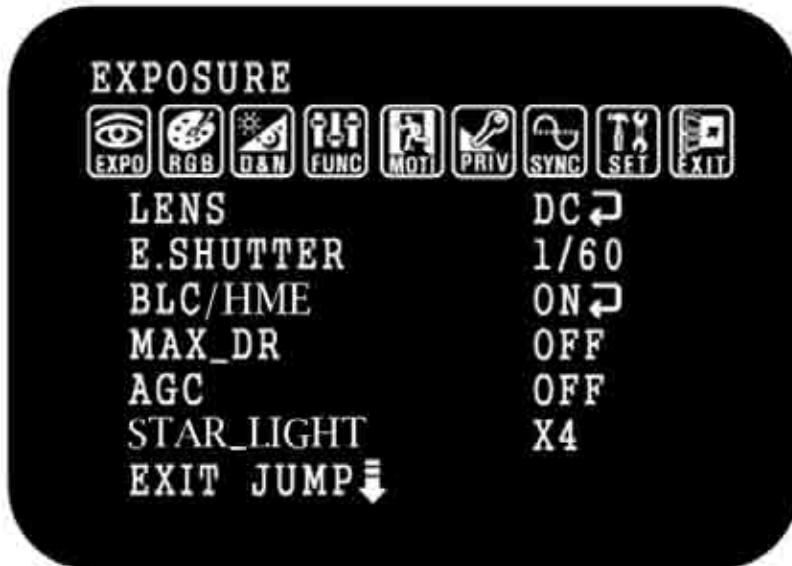

PRECAUTIONS

- Do not open or modify.
- Do not open the case except during maintenance and installation, for it may be dangerous and can cause damages.
- Do not put objects into the unit.
- Keep metal objects and flammable substances from entering the camera. It can cause fire, short-circuits, or other damages.
- Be careful when handling the unit.
- To prevent damages, do not drop the camera or subject it to shock or vibration.
- Do not install near electric or magnetic fields.
- Protect from humidity and dust.
- Protect from high temperature.
- Be careful when installing near the ceiling of a kitchen or a boiler room, as the temperature may rise to high levels.
- Cleaning
- To remove dirt from the case, moisten a soft cloth with a soft detergent solution and wipe.
- Mounting Surface
- The material of the mounting surface must be strong enough to support the camera.

FCC COMPLIANCE

This equipment has been tested and found to comply with the limits for a Class B digital device, pursuant to Part 15 of the **FCC** rules. These limits are designed to Provide reasonable protection against harmful interference .when the equipment is operated in a residential environment. This equipment generates, uses, and radiates radio frequency energy; and if it is not installed and used in accordance with the instruction manual, it may cause harmful interference to radio communications.

WARNING: Changes or modifications are not expressly approved by the manufacture.

TROUBLESHOOTING

Before sending your camera for repair, check the following or contact our technical specialist.

No VIDEO

Check the coaxial cable and make sure it is connected securely.

Check the lens' iris adjustment at the menu setup of the camera.

Check the power supply and make sure the camera has the proper voltage and current.

Out-of-Focus VIDEO

Check the clear dome cover and the lens for dirt or fingerprints. Use a soft cloth and gently clean.

Check the lens manual focal and zoom adjustment. Field test monitor is recommended.

FEATURES

- 1/3" Sony Super HAD II CCD
- High Resolution 560 TV Lines
- 3.3 ~ 12mm Varifocal Auto Iris Lens
- Electronic Day and Night
- Star-Light (Super Low Light Technology)
- DRC (Dynamic Range Compressor)
Dark spots in images particularly become more visible without overexposing the bright spots to create one perfect image.
- 3D-DNR (3D Digital Noise Reduction)
Produces less noise and more color during low-light application.
- HME (Highlight Mask Exposure)
Masks overly exposed light to produce a true video image of any environment.
- BLC (Back Light Compensation)
- Programmable Privacy Zone (6) & Motion Detection
- Easy Icon Driven OSD Menu with Built-In Joystick
- Auto Sensing 12VDC or 24VAC with Line Lock
- No Fog or Condensation under Any Weather Condition

DIMENSION (mm) & POWER REQUIREMENT

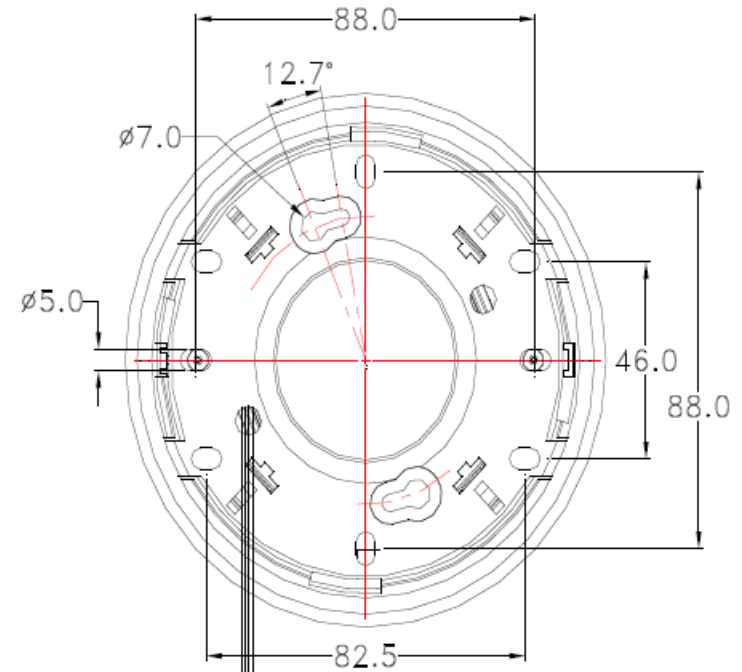
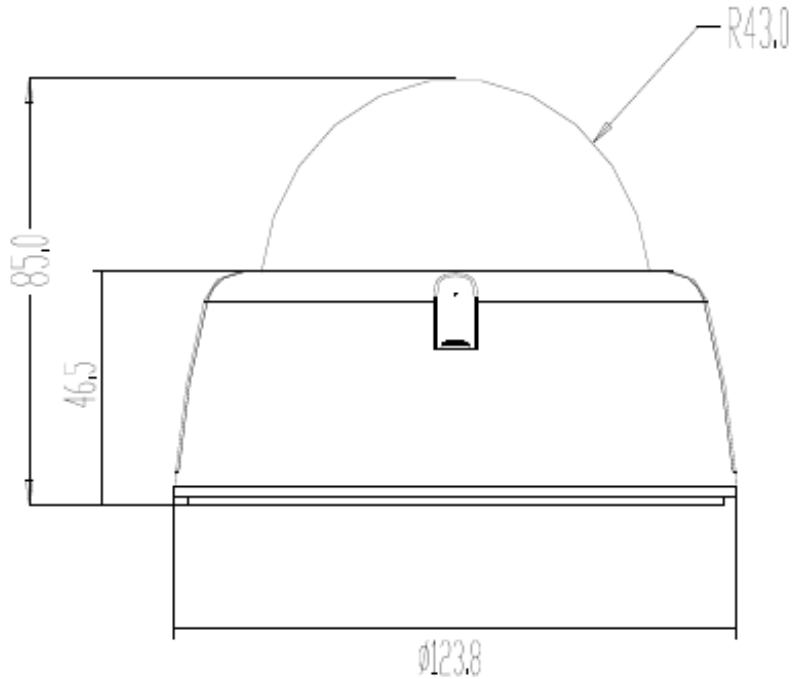

POWER REQUIREMENT:

12VDC @1A
24VAC @ .500mA

Power Wire Maximum Distance

Wire Gauge	12VDC	24VAC
24 AWG	80ft	323ft
22 AWG	128ft	513ft
20 AWG	203ft	815ft
18 AWG	323ft	1295ft
16 AWG	514ft	2056ft
14 AWG	816ft	3264ft
12 AWG	1295ft	5183ft
10 AWG	2057ft	8228ft

COAXIAL CABLE TYPE MAXIMUM DISTANCE

RG59/ U	750feet
RG6/U	1,000feet
RG11/U	1,500feet

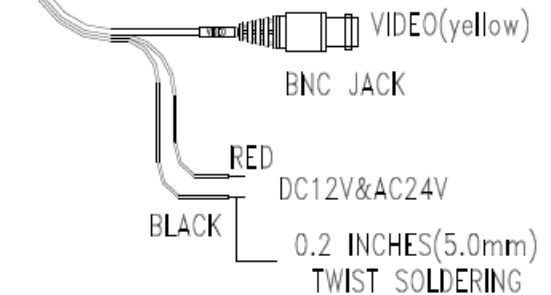

INSTALLATION

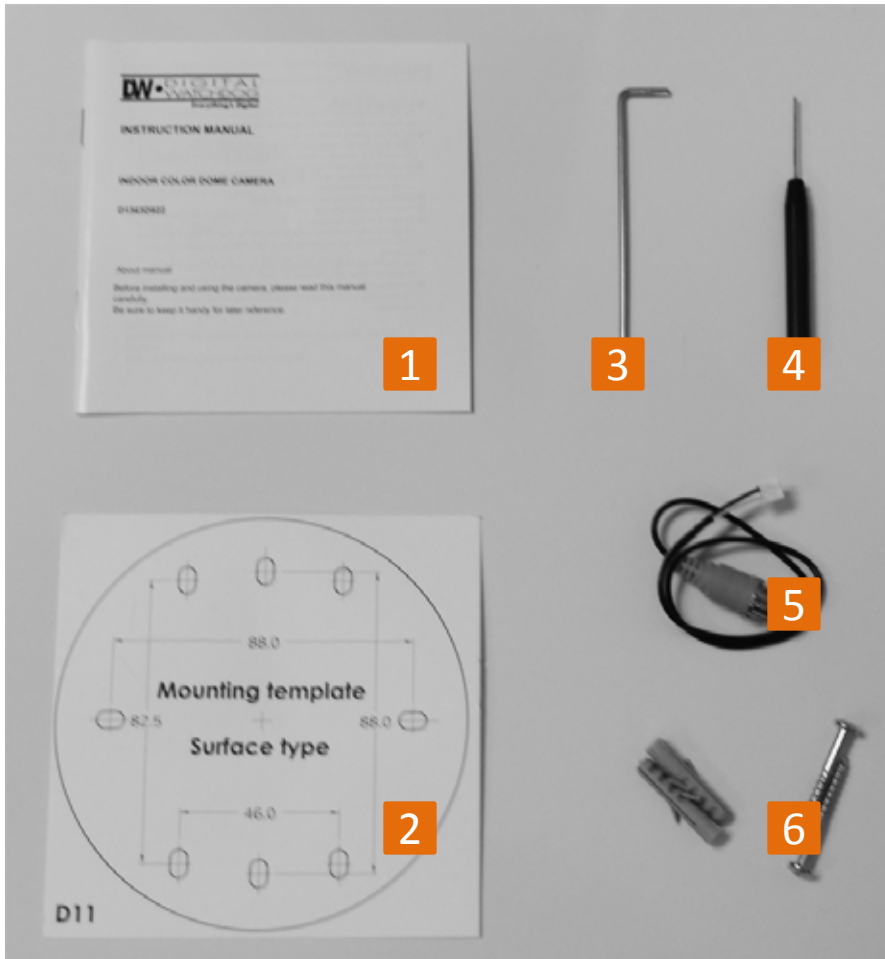

Included with DW Indoor Dome Camera:

1. User Manual
2. Mounting Template
3. Security L-Key
4. Single Sided Hex Key
5. Secondary BNC Cable for a Field Monitor
6. Two (2) Screws and Two (2) Dry Wall Anchors

Camera Installation

Use the mounting template to mount the camera.

Using the security L-key to loosen the four screws that secure the vandal proof dome cover, Remove the vandal proof dome cover to access the screw holes to mount the camera.

NOTE: Keep the lens and the vandal proof cover free from dust or fingerprint.

INSTALLATION

- A. Loosen the fixing screw using the L-Wrench.
- B. Separate the upper case and base case.
- C. Loosen the inner screws using a screwdriver.
- D. Detach the gimbal from the base case.
- E. Cut a hole in the ceiling for routing the cables.
- F. Place the camera horizontally on the ceiling.
Drill the screw holes at the marked two positions.
- G. Pass the power cable and video cable from the camera unit through the cable hole in the ceiling.
- H. Align the screw holes of the camera unit with the holes in the ceiling.
Secure the camera with the two screws.
- I. Fix the gimbal to the base.
- J. Install and adjust the camera unit.
- K. Adjust the dome to show the lens through the camera window. Attach to the base.
- L. Put the upper case and the base together
- M. Tighten the screw to fasten the upper case and base case.

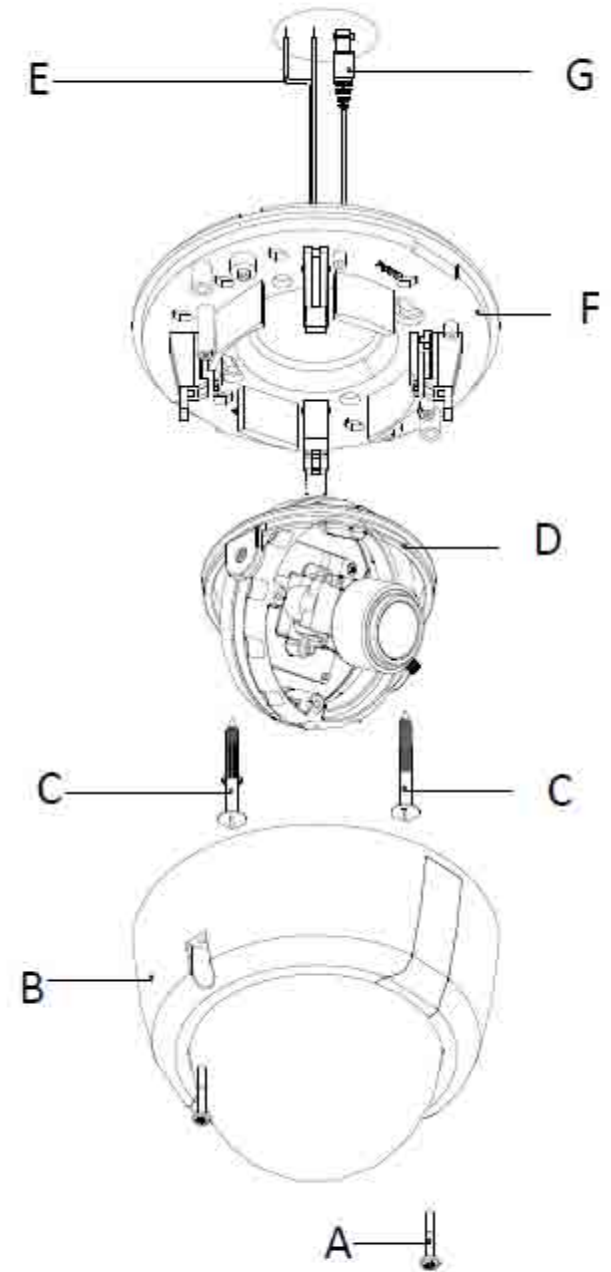

CONNECTION

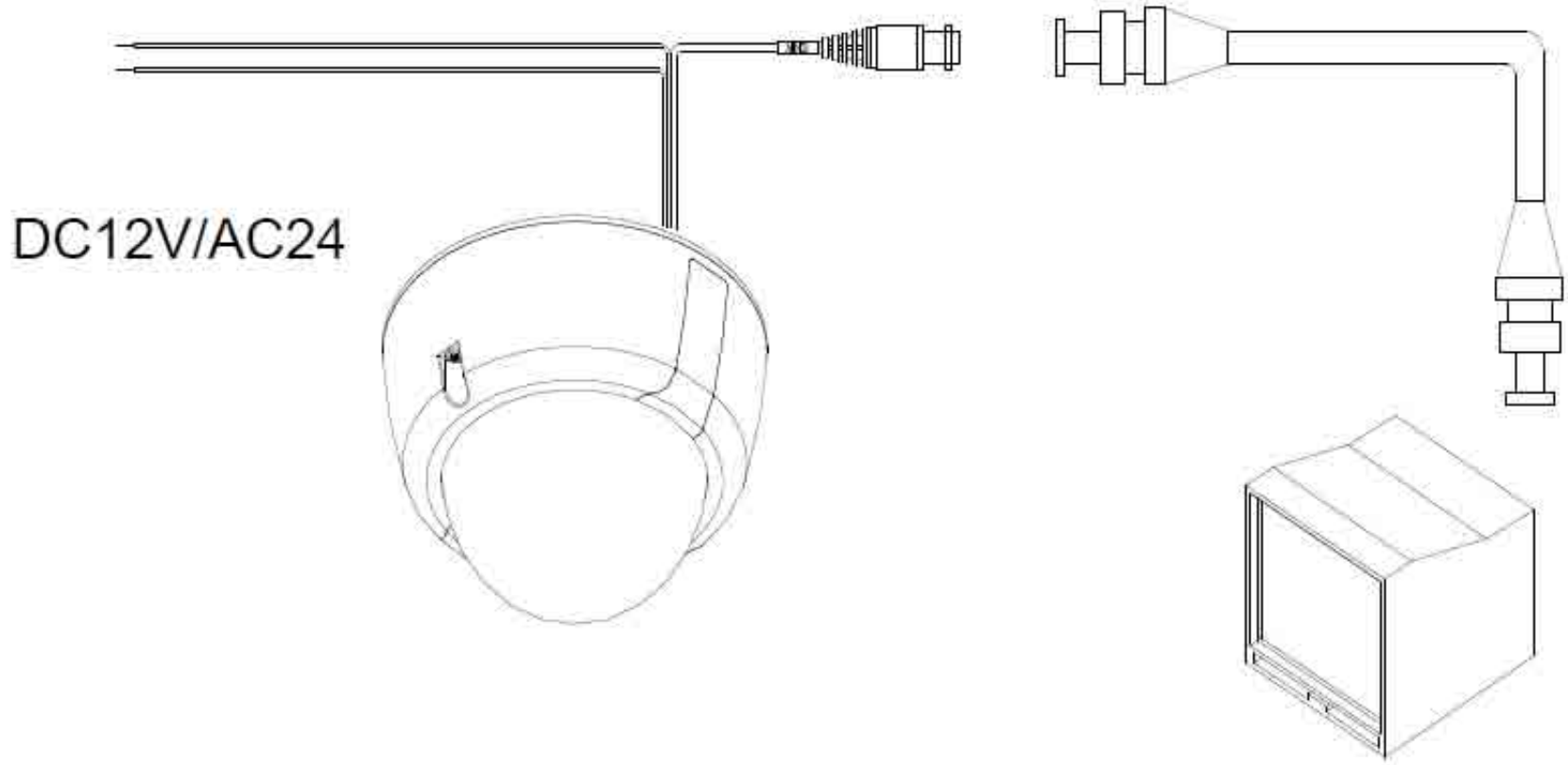

LENS ADJUSTMENT

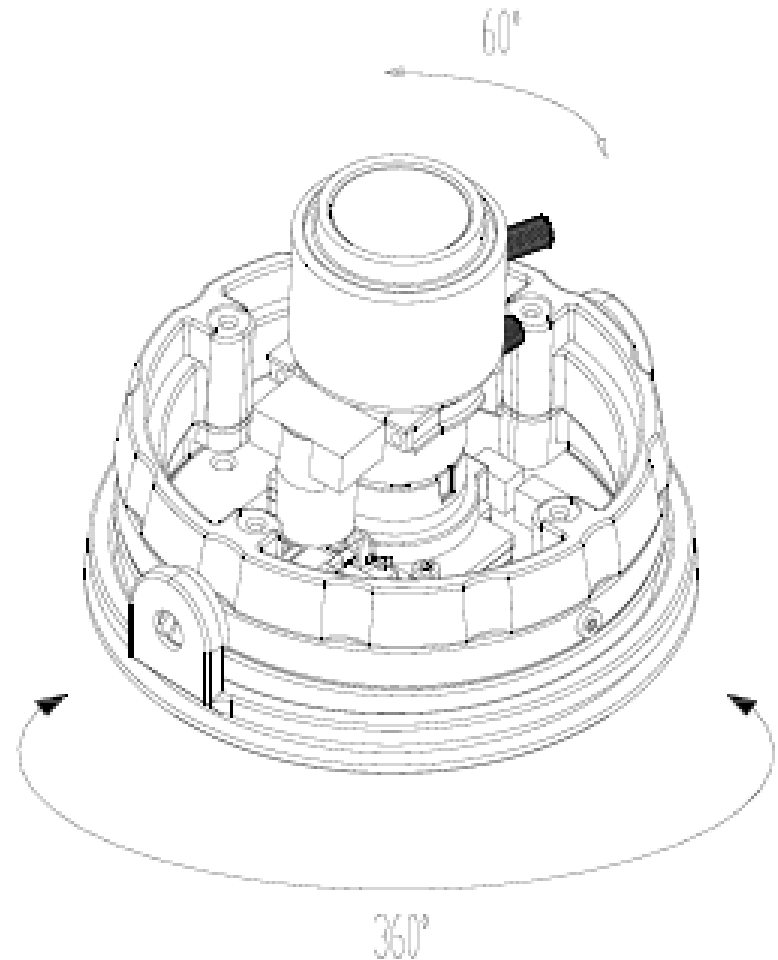

- A. Adjust the panning (360°) and tilt (60°) positions.
- B. Use the Zoom lever to set the zoom position.
- C. Use the Focus lever to set the focus.

SETTING THE CAMERA

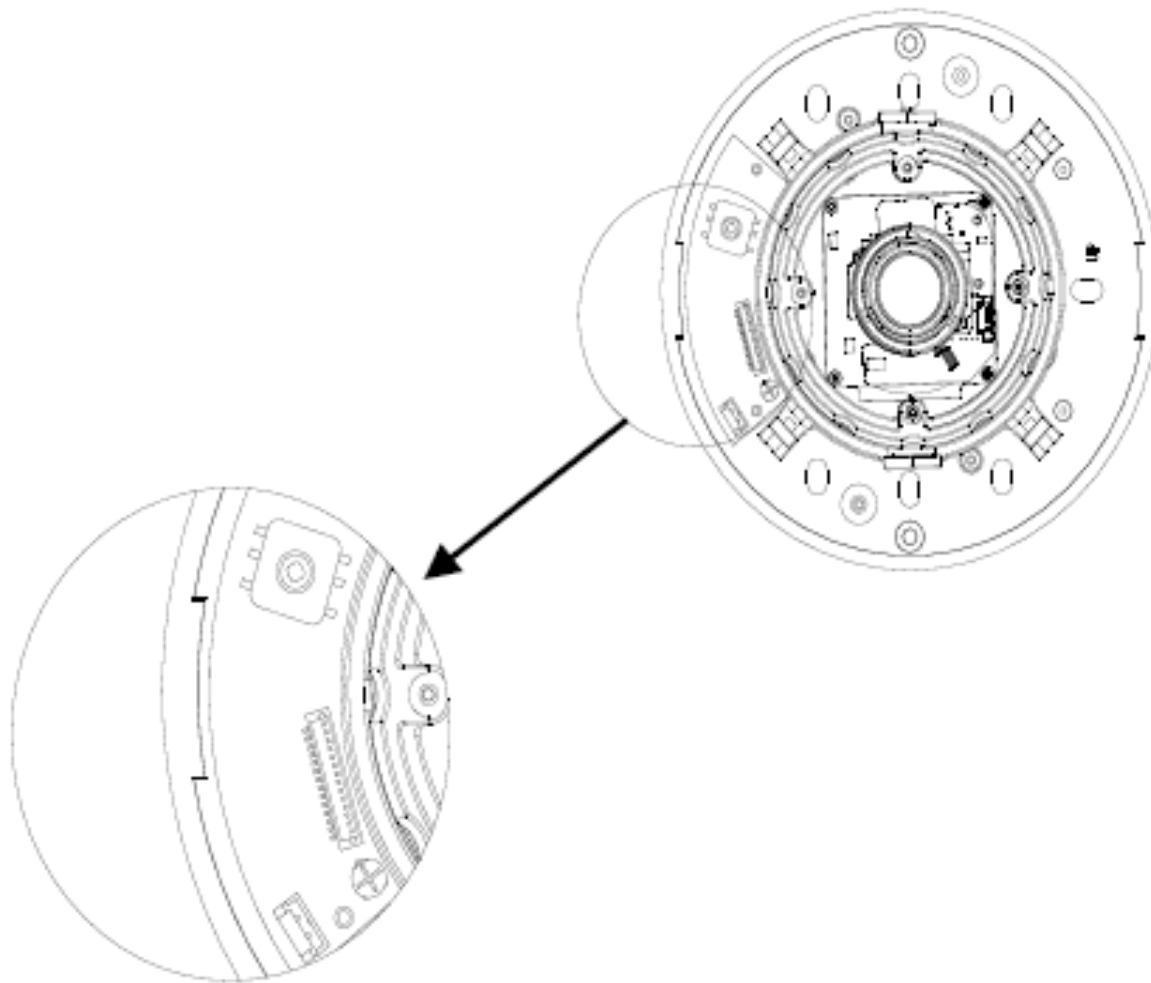

EXPOSURE

LENS	DC (0~100) / MANUAL / VIDEO. (DC Lens is recommended.)
SHUTTER	1/160 / 1/100 / FLC / 1/250 ~ 10000 / SENS-UP x2 ~ x250
BLC	OFF / ON BLC (Back Light Compensation)
AGC	HIGH / MIDDLE / LOW / OFF AGC (Auto Gain Control)
MAX-DR	OFF / ON (0 ~ 20) (Electronic Wide Dynamic Range)
STAR-LIGHT	AUTO (x2 ~ x250) / OFF (x32 is recommended.)
EXIT JUMP	EXIT / SAVE&EXIT / FACTORY RESET

COLOR

WB MODE	AWC / ATW / MANUAL / PUSH LOCK
R-Y GAIN	0 ~ 100
B-Y GAIN	0 ~ 100

DAY & NIGHT

Day & Night Mode	<p>AUTO / COLOR / BW / EX-CONT</p> <p>COLOR ----> BW : Switching from color to BW; if the number is higher, the camera will only switch during a super low light condition. BW ----> COLOR : Switching from BW to color; this number should always be lower than COLOR to BW Read Time: Time interval to switch from Color to Black-and-White</p>
	COLOR
	B&W: (BURST:OFF/ON) When the burst is OFF will make less noise
C-SUP	Color Suppression :Color will be reduced at low illumination, if the C-SUP Level is higher. 0 ~ 100 (Not Available when DNR is On.)
A-SUP	Aperture Suppression : The sharpness of the edges will be reduced at low illumination, if A-SUP Level is higher. 0 ~ 100 (Not Available when DNR is On.)
EXIT JUMP	EXIT / SAVE&EXIT / FACTORY SET

FUNCTION

MIRROR	OFF / MIRROR / V-FLIP / ROTATE
SHARPNESS	0 ~ 31
GAMMA	0.05 ~ 1.00 / USER
FREEZE	OFF / ON
NEGATIVE	OFF / ON
3D-DNR	OFF / LOW / MIDDLE / HIGH 3D-DNR (3D Digital Noise Reduction)
D-ZOOM	OFF / ON (x1.0 ~ x32 PTZ)
SLC	OFF / ON SLC (Side Light Compensation)
HME	OFF / ON HME (Highlight Masking Exposure)
DIS	OFF / ON DIS (Digital Image Stabilizer)
EXIT JUMP	EXIT / SAVE&EXIT / FACTORY SET

MOTION (OMNI-Focus Lens Only)

MOTION	OFF / ON
	SET WINDOW
	ALL SET (Set the Entire Screen)
	ALL CLEAR (Clear the Entire Screen)
	SENSITIVITY (1 ~ 120)
	SHOW INDICATOR (OFF / ICON / TRACE)
	DELAY OUT (1 ~ 15) Motion Alarm Zoom-In Delay
EXIT JUMP	EXIT / SAVE&EXIT / FACTORY SET

PRIVACY

MASK 1 OFF / ON 

MASK 2 OFF / ON 

MASK 3 OFF / ON 

MASK 4 OFF / ON 

MASK 5 OFF / ON 

MASK 6 OFF / ON 

EXIT JUMP

EXIT / SAVE&EXIT / FACTORY SET

SETUP

CAMERA ID

0 ~ 255

TITLE

OFF / ON

DPC

OFF / AUTO
DPC (Dead Pixels Cancellation)

MONITOR

CRT / LCD

LANGUAGE

English, Japanese, Chinese

BAUDRATE

2400 / 4800 / 9600 / 14400 / 19200 / 38400.
Protocol is Pelco-D (fixed cannot be changed; hardcoded into the DSP)

OMNI LENS

OFF / 1 ~ 10 (for OMNI-PLUS CAMERA only)

EXIT JUMP

EXIT / SAVE&EXIT / FACTORY SET

SYNC

SYNC

INTERNAL / AUTO

V-PHASE

0 ~ 199

EXIT JUMP

EXIT / SAVE & EXIT / FACTORY SET

EXIT

EXIT

Exit the menu

SAVE&EXIT

Exit the menu and save the setting

FACTORY SET

Reset the menu setting to factory default

SPECIFICATIONS:



5436 W Crenshaw St. Tampa, FL 33634

Tel: 866-446-3595 / 813-888-9555

Fax: 813-888-9262

www.Digital-Watchdog.com

technicalsupport@dwcc.tv

Technical Support Hours: Monday-Friday

8:30am to 8:00pm Eastern Time



Camera TYPE	Color / BW	D1363D
	Mount	Surface
Image	Device	Super HAD II CCD
	Size	1/3"
	Pixels-Total	811(H) x 508 (V)
Scanning	Pixels-Effective	768(H) x 494 (V)
	System	525 line, 2:1Interlace
	Horizontal Frequency Internal Mode	15,734Hz
	Vertical Frequency Internal Mode	59.94Hz
Min. Scene Illumination	F1.2 x256 Star-Light	0.14 Lux 0.0005 Lux in Color
Functions	BLC	ON / OFF
	AGC	HIGH / MIDDLE / LOW /OFF
	DRC	OFF / INDOOR / OUTDOOR
	Mirror	OFF / MIRROR / V-FLIP / ROTATE
	STAR-LIGHT	AUTO (x2 ~ x250) / OFF
	3D-DNR	OFF / ON (0~100)
	HME	OFF / ON
	Privacy Zone	6 Programmable Zone / Size
	Lens	Focal Length
Resolution	Horizontal	560 TV Lines [Color]; 580 TV Lines [BW]
Video Output	VBS 1.0Vp-p	VBS 1.0Vp-p(75 Load)
S/N Ratio	S/N Ratio	50dB
OSD	OSD	YES
Environmental Conditions	Operating Temperature	-10°C ~ +55°C(14°F ~ 131°F)
	Humidity	Less than 90%
Power	Power Requirement	12VDC / 24VAC
	Power Consumption	1.96 [W] / 2.2 [W]
Physical Specifications	Dimensions	85 x 123.8 mm
	Weight	0.6bs
	Nema Type	IP66
	Certifications	FCC, RoHS, CE

Starlight D1363D, D1363D922 Indoor Dome Camera

User Manual Version #1:
Camera without ICON Menu



ABOUT MANUAL

Before installing and using the camera, please read this manual carefully.

Be sure to keep it handy for future reference.

OSD SWITCH FUNCTIONS

SETUP	
LENS	[DC] - Brightness (DC Lens is recommended.)
	Manual. Shutter is available.
SHUTTER	FLK (Flicker Free)
	ESC (Electronic Shutter Control) - Brightness Adjustment
	Manual Adjustment
WHITE BALANCE	ATW 1800K ~10500K (ATW is recommended).
	Manual Adjustment
	AWC (Auto White Balance)
BACKLIGHT	OFF / LOW / MIDDLE / HIGH
AGC	NORMAL / HIGH / OFF (When the AGC is Off, DNR is not available.)
DNR	LOW / MIDDLE / HIGH / OFF
SENS-UP	AUTO x2 ~ x128 / OFF
SPECIAL	
CAMERA ID	OFF / ON
DAY NIGHT	AUTO / BW / EXTERNAL / COLOR
SYNC	INTERNAL / LINE
MOTION DETECTION	OFF / ON
PRIVACY	OFF / ON
MIRROR	OFF / ON
SHARPNESS	OFF / ON Level Adjustment
RESET	
RETURN	Return to main setup.

SPECIFICATIONS:



5436 W Crenshaw St. Tampa, FL 33634

Tel: 866-446-3595 / 813-888-9555

Fax: 813-888-9262

www.Digital-Watchdog.com

technicalsupport@dwcc.tv

**Technical Support Hours: Monday-Friday
8:30am to 8:00pm Eastern Time**



Model	D1363D, D1363D922	
	Mount	Surface
Image	Device	1/3" Super HAD CCD
	Pixels-Total	811(H) x 508(V)
	Pixels-Effective	768(H) x 494(V)
Scanning	System	525 line, 2:1Interlace
	Horizontal Frequency Internal Mode	15,734Hz
	Vertical Frequency Internal Mode	59.94Hz
OSD Functions	Day & Night	AUTO / COLOR / BW
	Sens-up	AUTO / OFF (x128)
	DNR	OFF / LOW / MIDDLE / HIGH
	AGC	ON / OFF (Gain Adjust)
	AWB	ATW / AWC / Manual
	Motion Detection	ON / OFF (Area / Sensitivity)
	Privacy Zone	4 Programmable Zone / Size
Lens	Focal Length	3.3 ~ 12mm
		9 ~ 22mm
Resolution	Horizontal	540 TV Lines
Video Output	VBS 1.0Vp-p	VBS 1.0Vp-p(75 Load)
S/N Ratio	S/N Ratio	50dB
Environmental Conditions	Operating Temperature	-10℃ ~ +55℃(14°F ~ 131°F)
	Humidity	Less than 90%
Power	Power Requirement	12VDC / 24VAC
	Power Consumption	12VDC: 222mA 24VAC: 198mA
Physical Specification	Dimensions(W x H)	123.8 x 85mm
	Weight	1.0 lbs
Certifications	CE, FCC, RoHS	Certified