

AT-8900 SERIES

HARDWARE REFERENCE

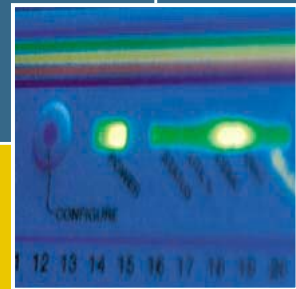
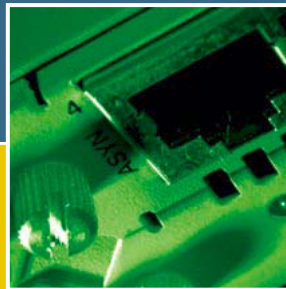
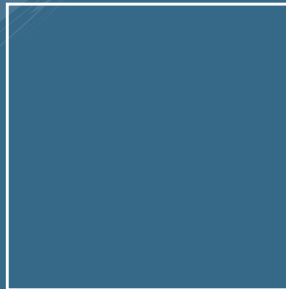

AT-8900 Series Hardware Reference
Document Number C613-03075-00 REV A.

Copyright © 2003 Allied Telesyn International, Corp. 18900 North Creek Parkway, Suite 200, Bothell, WA 98011, USA.

All rights reserved. No part of this publication may be reproduced without prior written permission from Allied Telesyn.

Allied Telesyn International, Corp. reserves the right to make changes in specifications and other information contained in this document without prior written notice. The information provided herein is subject to change without notice. In no event shall Allied Telesyn be liable for any incidental, special, indirect, or consequential damages whatsoever, including but not limited to lost profits, arising out of or related to this manual or the information contained herein, even if Allied Telesyn has been advised of, known, or should have known, the possibility of such damages.

All trademarks are the property of their respective owners

Contents

Contents	1
Models Covered By This Reference	2
Why You Should Read This Reference	2
Where To Find More Information	3
Hardware Description	3
Switch Overview	3
AT-8900 Series Switch Models	5
AT-8948	5
Online Documentation	6
Accessing the CD-ROM and Online Documentation	6
AT-TFTP Server	7
Using Windows Terminal and Windows Hyperterminal	8
Switch Start-up	11
To log In	11
To access help	12
Start-up Procedures	12
RS-232 Terminal Port (ASYNO)	15
Useful Cables	16
RS-232 Terminal and Modem Cables	16
Cables for RJ-45 Ethernet LAN Interfaces	17
Test Facility	19
Ethernet LAN Port Tests	19
Other Interface Tests	22
Power Supply Units (PSUs)	23
Port, Connector, and Cable Combinations	24
Troubleshooting	24
LEDs and What They Mean	24
Check these first	26
Some common problems and how to solve them	27
Expansion Options	28
SFP transceivers	28
Compact Flash	29
Dual In-line Memory Modules (DIMMs)	32
Restricted Procedures	32
Lithium Battery	32
Installing DIMM	32
Testing DIMM	35
Diagnostics	36
Contacting Us	38

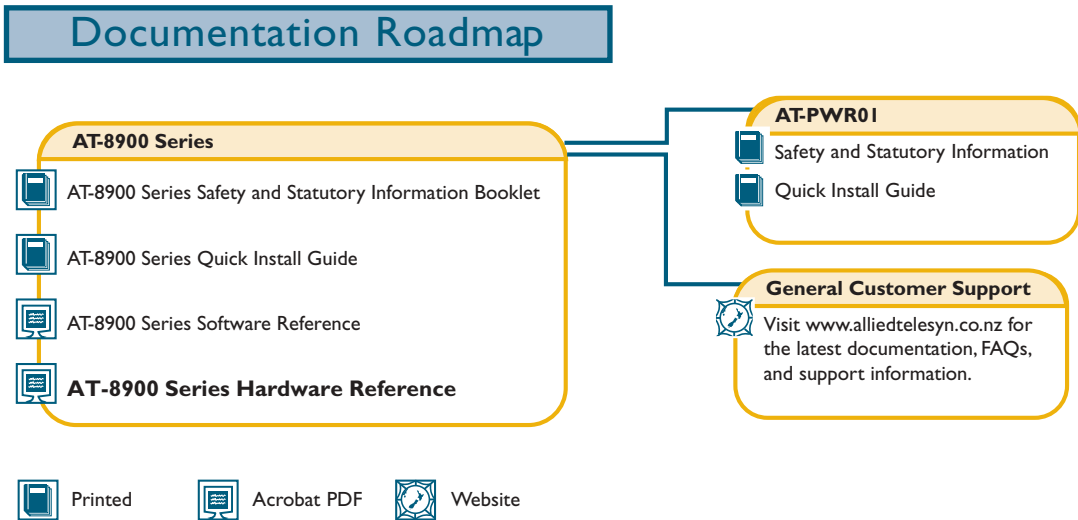

Models Covered By This Reference

This Hardware Reference includes information on the following products:

- AT-8948
- AT-PWR01 (AC power supply unit)
- AT-PWR01 (DC power supply unit)
- AT-FAN01 (fan only module)

The latest AT-8900 Series Hardware Reference can be found at <http://www.alliedtelesyn.co.nz/support/at8900>.

Why You Should Read This Reference

This Reference provides hardware related information for AT-8900 Series switches, including information on Power Supply Units.

The Reference has two primary aims:

1. To familiarise you with the hardware features of AT-8900 Series switches and their Power Supply Units (PSU) units.
2. To assist you with setting up and maintaining your AT-8900 Series switch and PSU units.



Keep this Reference (or its CD-ROM) in a safe place, you will need it if you purchase switch expansion options (DIMM) in the future.



This Reference does not cover software configuration or software installation procedures. For information on software, refer to the AT-8900 Series Software Reference.

Where To Find More Information

The Documentation and Tools CD-ROM bundled with each switch contains the complete Document Set for AT-8900 Series switches and their power supply units, as well as tools for switch management. This includes the following:

- The *AT-8900 Series Statutory and Safety Information booklet*, which provides safety and statutory information for the AT-8900 switch.
- The *AT-PWR01 Statutory and Safety Information booklet*, which provides safety and statutory information for the power supply units.
- The *AT-8900 Series Quick Install Guide*, which outlines the procedure for installing switch units.
- The *AT-PWR01 Quick Install Guide*, which outlines the procedure for installing power supply units and fan only modules.
- The *AT-8900 Series Software Reference*, which provides detailed information on configuring the Switch and its software.

The documents listed here can also be downloaded from the AT-8900 Series Support Site at <http://www.alliedtelesyn.co.nz/support/at8900>.

Hardware Description

This section provides an overview of hardware features for the AT-8900 Series switches.

Switch Overview

Developed to meet the exceptionally high performance demands of high end applications, AT-8900 Series switches deliver wire-speed switching performance, in a robust 1U rack mount platform.

The AT-8900 Series switches have:

- 4 Small form-factor pluggable (SFP) Gigabit Ethernet uplink sockets
- 48 10/100BASE-T RJ-45 ports bridging traditional copper/fibre divides
- 1 compact flash socket

And these features are accessible on the front panel of the switch.

In addition, dual hot-swappable load-sharing power supplies provide space saving reliability and redundancy, perfect for the high-density rack environment where space is at a premium.

Dimensions

- Height = 44.5 mm (plus 5.1 mm if the rubber feet are used)
- Width = 440 mm (excluding rack-mounting brackets)
- Depth = 440 mm (excluding PSU handles)
- Weight = Not more than 8.5 kg (includes single PSU and PSU fan only module)

Mounting System

- 1U rack mounting

Environmental Conditions

- Operating temperature range: 0 to 50° C (32 to 122° F)
- Storage temperature range: -25 to 75° C (-13 to 167° F)
- Relative humidity range: 5 to 95% non-condensing
- Operational altitude: 3,050 metres maximum (10,000 feet)

Regulatory Standards

AC models

- EMC: EN55022 class A, FCC class A, and VCCI class A
- EN61000-3 levels 2 (Harmonics), and 3 (Flicker)
- Immunity testing to EN55024
- Safety: UL60950, CAN/CSA-C22.2 NO. 60950-00, EN60950, AS/NZS3260
- Certification: UL, cUL, TUV

DC models

- EMC: EN55022 class A, FCC class A, and VCCI class A
- Immunity testing to EN55024
- Safety: UL60950, CAN/CSA-C22.2 NO. 60950-00, EN60950, AS/NZS3260
- Certification: UL, cUL, TUV

LEDs

- Port and System status LEDs
- For a complete list of LEDs and their functions, see “LEDs and What They Mean” on page 24

Power Supply Unit

- PSUs are hot-swappable and load share

AC models

- Universal 100/240 VAC 47/63 Hz input
- Maximum continuous current draw, 2.2A at 100V, 1.1A at 230V
- Maximum inrush current (cold start at 25° C/77° F), 70A at 240V, 32A at 115V

DC models

- 40 to 60 V, 48 V nominal
- Supports either positive grounded or negative grounded operation
- Maximum continuous current draw, 3.9A at 36v
- Maximum standby current, 100mA

Switching Core

- Application-Specific Integrated Circuit (ASIC) switch chip
- Non-blocking L2 and L3 IP Switching
- 256K IPv4 address table
- 4K multicast table
- 4K logical Layer 3 interfaces
- Shared 32 MByte DDR-SDRAM packet buffer

Processing Core

- 400 MHz RISC Processor
- 128 MBytes Synchronous DRAM (expandable to 256 MByte or 512 MByte with DIMM)
- 32 MBytes of fixed flash
- Compact flash socket for hot swappable expansion of flash memory up to 128 MBytes
- 512kBytes of SRAM
- 32/66 PCI bus for 32bit/33MHz
- Silicon ID chip storing serial number, board ID, and MAC address

Asynchronous Serial Port

- Up to 115 kbps
- Universal Asynchronous Receiver Transmitter (UART)
- Standard RJ-45 connector
- Hardware-flow control

AT-8900 Series Switch Models

This section provides hardware descriptions for individual switch models.

AT-8948

(See Figure 1 on page 6)

- 48-port 10/100BASE-T (RJ-45 connectors), MDI or MDIX, full or half duplex
- 4-port 1000BASE-X SFP uplink sockets, full duplex
- Compact flash socket
- One DIMM socket for expansion of Synchronous DRAM
- Auto-negotiating Layer 3 Managed Switch
- Hot-swappable load sharing PSUs
- AC or DC PSU options

Figure 1: Front and rear panels of the AT-8948.

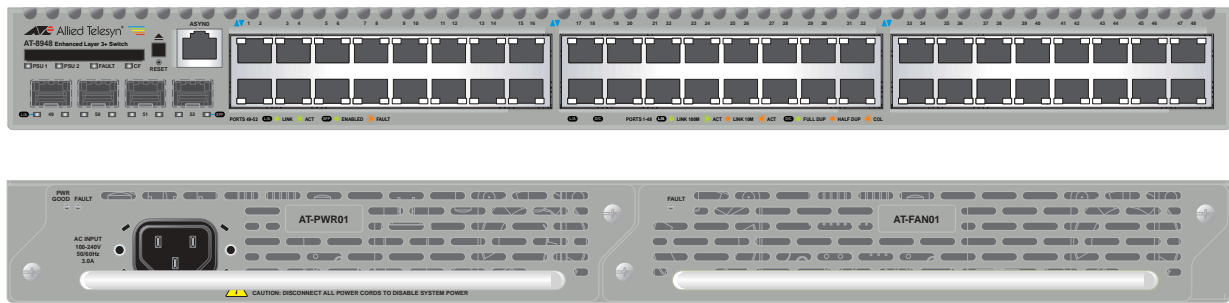

Online Documentation

This section provides a step-by-step guide to accessing online documentation. Your computer must have Adobe Acrobat Reader installed to view online documentation.

Accessing the CD-ROM and Online Documentation

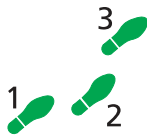

Follow these steps to access the CD-ROM and online documentation:

1. Insert the Documentation and Tools CD-ROM in the CD-ROM drive.

2. If the Welcome screen does not appear.

Select "Run" from the Start Menu (Windows 95, 98, 2000 or NT 4.0).

Type `d:\start.exe` (where d: is the CD-ROM drive letter) and click OK.

3. To view a document.

Click on the document title.

4. To navigate around PDF documents.

Use the toolbar buttons, keyboard shortcuts, or commands from the Document menu to page through the document.

Click on a bookmark, thumbnail or hypertext link to jump to a specific section or topic.

Use the Search command to search for keywords or phrases.

For more information about using the Adobe Acrobat Reader, select "Reader Guide" from the Help menu.

5. To install any of the tools included on the CD-ROM.

Click on a link in the Welcome screen.

AT-TFTP Server

This section provides information on how to access and use AT-TFTP Server. AT-TFTP Server can be used to transfer configuration files as well as to download software patches and releases.

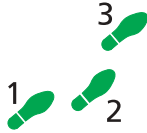

To use AT-TFTP Server, follow these steps:

1. If AT-TFTP Server has not yet been installed.

Install it now from the AT-8900 Series Documentation and Tools CD-ROM.

Choose AT-TFTP Server from the Start > Programs > Allied Telesyn > AT-TFTP Server menu.

2. To set preferences for the AT-TFTP Server.

Select "Options" from the File menu to display the "Set Preferences" dialog box.

The "Default file transfer directory" field specifies the directory that AT-TFTP Server will read from or write to for file requests that do not include a directory specification.

To prevent unauthorised access to private directories, enter a path name in the "Restrict to directory" field. AT-TFTP Server will use only the specified directory, even if file requests contain references to other directories.

Select "Read only" to prevent files being written to the PC. To use the PC to archive scripts created using the switch's CREATE CONFIG command, select "Read Write".

Make any required changes and click "OK".

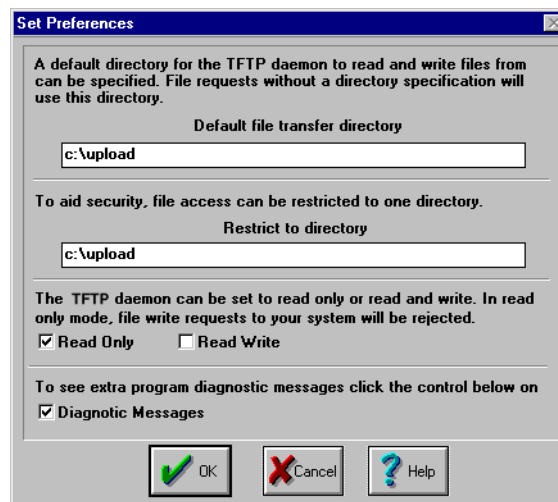

3. To load a file from AT-TFTP Server to the Switch.

On a terminal connected to the RS-232 Terminal Port (ASYN0), type the command:

```
LOAD METHOD=TFTP FILE=filename SERVER=ipadd DEST=FLASH
```

where *filename* is the name of the file to download and *ipadd* is the IP address of the PC running AT-TFTP Server.

4. To save a TFTP Server log.

Select "Save As" from the File menu.

TFTP requests are logged to the AT-TFTP Server main window.

Using Windows Terminal and Windows Hyperterminal

You can use a PC running terminal emulation software as the manager console, instead of a terminal. There are many terminal emulation applications available for PCs, but the most readily available are the Terminal and HyperTerminal applications included in Microsoft Windows 95, 98, 2000, and Windows NT 4.0. In standard Windows installations, HyperTerminal is located in the Start > Programs > Accessories menu.

The key to successful use of terminal emulation software with the switch is to configure the software and switch with matching communications parameters. The following procedures describe how to configure Windows Terminal and HyperTerminal for the default RS-232 ASYN0 settings on the switch, but the same principles apply to other terminal emulation programs.

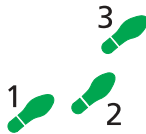

To configure Windows HyperTerminal for Windows 95, 98, 2000, & NT 4.0.

1. In Windows, select:

- Programs > Accessories > HyperTerminal.
- Double-click the Hypertrm.exe icon.

2. In the Connection Description dialog box:

- Enter a name for the connection (e.g., AT89001)
- Select an icon from the scrolling list.
- Click "OK".

3. In the Phone Number dialog box:

From the "Connect using:" drop-down list, select:

- "Direct to Com *n*" Where "COM *n*" is the COM port on the PC used to connect to the switch.
- Click "OK".



4. In the COMn Properties dialog box, set:

- Bits per second: 9600.
- Data bits: 8.
- Parity: None.
- Stop bits: 1.
- Flow control: Hardware.
- Click “OK”.

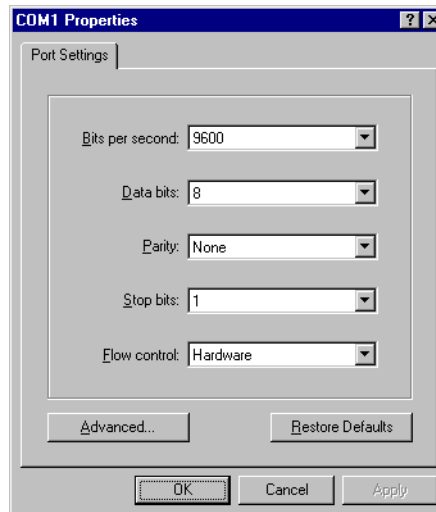
**5. From the File menu, select:**

- “Properties”

In the Connection Properties dialog box, click the Settings tab and set:

- “Function, arrow, and ctrl keys act as” to “Terminal keys”
- “Emulation” to VT100.



6. Click "ASCII Setup" to display the ASCII Setup dialog box. Uncheck:
- "Echo typed characters locally".
 - "Append line feeds to incoming line ends".

Set other parameters as required.

- Click "OK" twice to close all dialog boxes.

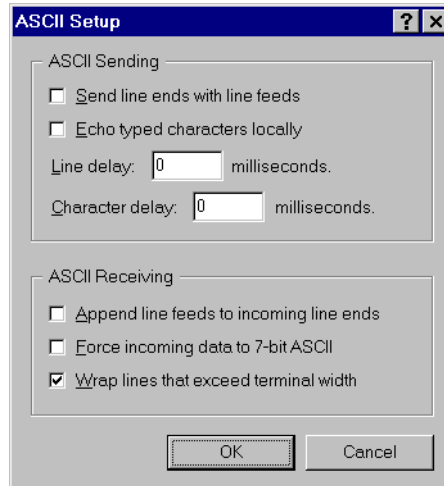

7. Save the current session. From the File menu, select:
- "Save".

This creates a connection icon with the name you assigned in the HyperTerminal group. To use the configuration:

- Double-click the connection icon in the HyperTerminal group.

When the HyperTerminal window appears, press:

- [Enter] a couple of times.

The switch's log in prompt will appear.

Switch Start-up

This section outlines the log in and start-up procedures for your switch. Although the switch will perform basic switching operations without being configured, you will need to go through these log in and start-up procedures if you wish to configure the switch and access its full layer 3 switching capabilities.

Before you can log in, the switch's chassis must have at least one power supply unit installed and operational, with either a power supply unit or fan only module installed in the other bay.

To log In

To log in you must first connect the switch to a terminal or PC. This can be done using the RS-232 Terminal Port (ASYN0). A terminal cable suitable for use with ASYN0 is supplied with each switch.

Using the supplied terminal cable, or a cable you have made by following the instructions in "Useful Cables" on page 16, connect your terminal or PC to ASYN0 on the switch.

Set the communication parameters on your terminal or terminal emulation program to:

- Baud rate: 9600
- Data bits: 8
- Parity: None
- Stop bits: 1
- Flow control: Hardware

See "Using Windows Terminal and Windows Hyperterminal" on page 8 for more information on configuring emulation software.

Ensure that any power switches are in the On position and that the switch is receiving power.

After the switch has booted, the log in prompt appears. If the log in prompt doesn't appear, press [Enter] two or three times.

When the switch boots for the first time it automatically creates an account with manager privileges. The account has the log in name "manager" and the password is "friend".

At the log in prompt, enter the log in name and password.

```
Log in: manager
```

```
Password: friend
```

The switch's command prompt appears and you can now configure the switch using the command line interface.



Change the password as soon as possible. Leaving the manager account with the default password is a serious security risk. Make sure that you remember the new password as there is no way to retrieve the password if it is lost.

Use the following command to change the account password:

```
set password
```

See the *AT-8900 Series Software Reference* for more information on configuring the switch.

To access help

Before help is used for the first time, the help files must be defined.

To define the files, enter:

```
set help=help-filename
```

where *help-filename* is the name of a help file stored in flash.

To see a list of files stored in flash, enter:

```
show file
```

Help files have an HLP extension.

To display a list of help topics, enter:

```
help
```

To display help on a specific topic, enter:

```
help topic
```

Alternatively, type a question mark (?) at the end of a partially completed command to see a list of valid options.

Start-up Procedures

When the switch starts up following either a power cycle or an operator-initiated reboot (using the Reset button or RESTART command), a series of start-up messages is sent to the terminal or PC connected to ASYN0 (Figure 2 on page 12).

Figure 2: Switch start-up messages.

```
INFO: Self tests beginning.
INFO: RAM test beginning.
PASS: RAM test, 131072k bytes found.
INFO: BBR tests beginning.
PASS: BBR test, 512k bytes found.
INFO: Self tests complete
INFO: Downloading switch software.
Force EPROM download (Y) ?
INFO: Initial download succeeded
INFO: Executing configuration script <boot.cfg>
INFO: Switch startup complete

Manager >
```

After the self tests are complete, the manager is given the option of forcing a mandatory boot from the EPROM (flash) release. The message:

```
Force EPROM download (Y)?
```

is displayed on the terminal or PC connected to ASYN0 and the switch pauses. If a key is not pressed within a few seconds, the start-up process will continue and all steps in the sequence will be executed. Pressing selected keys on the terminal immediately after the “Force EPROM download” message is displayed will change the switch start-up process (Table 1 on page 13).

Table 1: Switch start-up sequence keystrokes.

Pressing key...	Forces the switch to...
[Y]	Load the EPROM release, with no patch.
[S]	Start with the default configuration. Any boot script is ignored.
[Ctrl/D]	Enter diagnostics mode.

During the start-up process the switch will generate four different types of messages. All messages are preceded by one of the words INFO, PASS, FAIL, or ERROR. The significance of these words is shown in Table 2 on page 13.

Table 2: Switch start-up message classes.

Message	Meaning
INFO	An action will be taken by the system.
PASS	A test has been completed successfully.
ERROR	An error message that a test has failed, but the system will continue to operate.
FAIL	An error message that a fatal error condition has caused the system to halt in an unrecoverable fashion.

The possible messages and their meanings are:

INFO: Self tests beginning.

The code loader tests are about to begin.

INFO: RAM test beginning.

The RAM tests are about to begin.

PASS: RAM test, 131072k bytes found.

The RAM test passed, and the indicated amount of memory was found and will be used by the switch.

ERROR: RAM test 5. Error address = 00345678.

A RAM test failed, at the given address. In the example, it was the fifth test run. The RAM test repeats until it passes, so a number of messages like this may appear. This fault means that the memory system is faulty. If the fault continues, contact your Authorised Allied Telesyn distributor or reseller immediately.

INFO: BBR tests beginning.

The BBR battery tests are about to begin.

PASS: BBR test. Battery OK.

The BBR battery tests passed.

ERROR: BBR Battery low.

The BBR battery test failed, indicating that the battery is running low. The BBR battery will need to be replaced. Contact your Authorised Allied Telesyn distributor or reseller.

PASS: BBR test, 512k bytes found.

The BBR size/location test passed, with the indicated amount of BBR found.

FAIL: BBR test. Error address = 12345678.

The BBR size/location test failed at the given location. The test at this location failed, indicating the end of memory, but a valid location was discovered in the 255 long words following this location. The BBR system will need to be replaced. Contact your Authorised Allied Telesyn distributor or reseller.

FAIL: BBR test, only 16k bytes found.

The BBR size/location test completed, but only the displayed amount of memory was found. This amount is less than the minimum required to run the switch software.

INFO: Self tests complete.

The start-up tests have finished.

INFO: Downloading switch software.

The process of downloading the switch software and vector table from ROM is about to begin.

ERROR: Code load retried.

FAIL: Code load failed.

The load of the code from ROM to RAM failed. The load is retried a number of times. Each time a failure occurs, the ERROR message is displayed. If the maximum number of attempts is reached, the FAIL message is displayed.

INFO: Initial download succeeded.

The start-up tests and download are complete, and the switch software is about to be started. If the default install is a compressed release, the release will now be decompressed. This may take a few seconds.

INFO: Downloading compressed release. This may take up to 1 minute...

INFO: Loading software into memory. This may take up to 1 minute...

The main switch software is about to be loaded into RAM. If the release is a compressed release, the release will be decompressed.

INFO: Executing configuration script <script-name>

The configuration commands stored in <script-name> are being executed. If an error is found in the script, one or more ERROR messages will be displayed.

INFO: Switch startup complete.

The start-up process is complete and the switch will now perform basic switching operations. Further configuration will be necessary if you wish to access the switch's full layer 3 switching capabilities. See the *AT-8900 Series Software Reference* for detailed information on configuring the switch.

RS-232 Terminal Port (ASYN0)

This section introduces the switch's RS-232 Terminal Port (ASYN0), including its pin assignment and purpose.

The RS-232 ASYN0 Terminal Port is used to connect the switch to a management device for initial configuration and switch management tasks. This allows the switch's software to be accessed from a terminal, or a PC running terminal emulation software. You can also use ASYN0 to establish a network connection from a remote site using SLIP and a modem.

ASYN0 has an RJ-45 socket with an industry recognised pinout. This requires the use of a straight-through RJ-45 cable with an RJ-45 DB9F connector when connecting the switch to a terminal or PC. The socket is wired as a DTE and the pin roles are shown in Figure 3 on page 15 and listed in Table 3 on page 15.

See "Useful Cables" on page 16 for more information on suitable cables to use with ASYN0.

Figure 3: RS-232 Terminal Port Pin Numbers

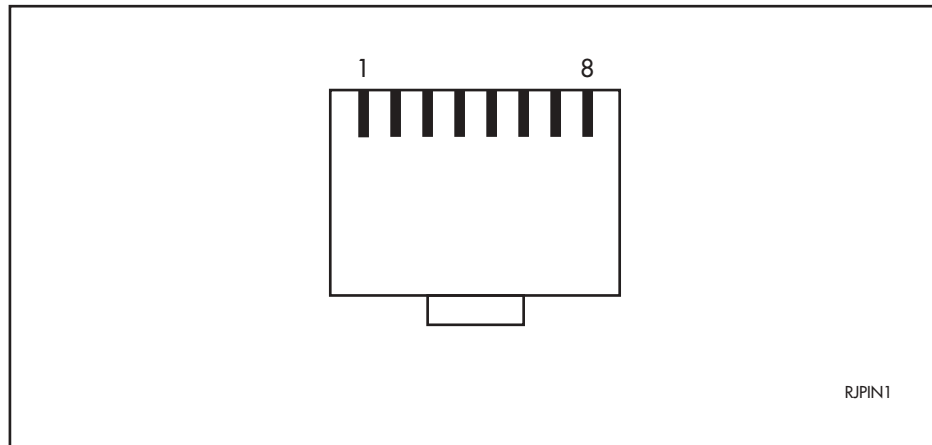

Table 3: Internal DTE pin roles.

Pin	Role
1	RTS
2	DTR ¹
3	TXD
4	GND
5	GND
6	RXD
7	DSR ¹
8	CTS

1. DTR and DSR are connected together but have no other internal connection.

Useful Cables

This section describes how to make management, test, and network cables for use with the switch's RS-232 (ASYN0) and RJ-45 interfaces.

RS-232 Terminal and Modem Cables

The list of terminal and modem cables described in this section is shown in Table 4 on page 16.

Table 4: Terminal and modem cable descriptions.

Cable type	Description
RS-232 RJ-45 to DB9 female terminal cable	Figure 4 on page 16
RS-232 RJ-45 to DB9 male modem cable	Figure 5 on page 17

How to wire cables to connect a standard VT100 compatible terminal, or a modem, to ASYN0 is shown in Figure 4 on page 16, and Figure 5 on page 17.

Figure 4: Pin wiring diagram for a standard DB9 male to female terminal cable.

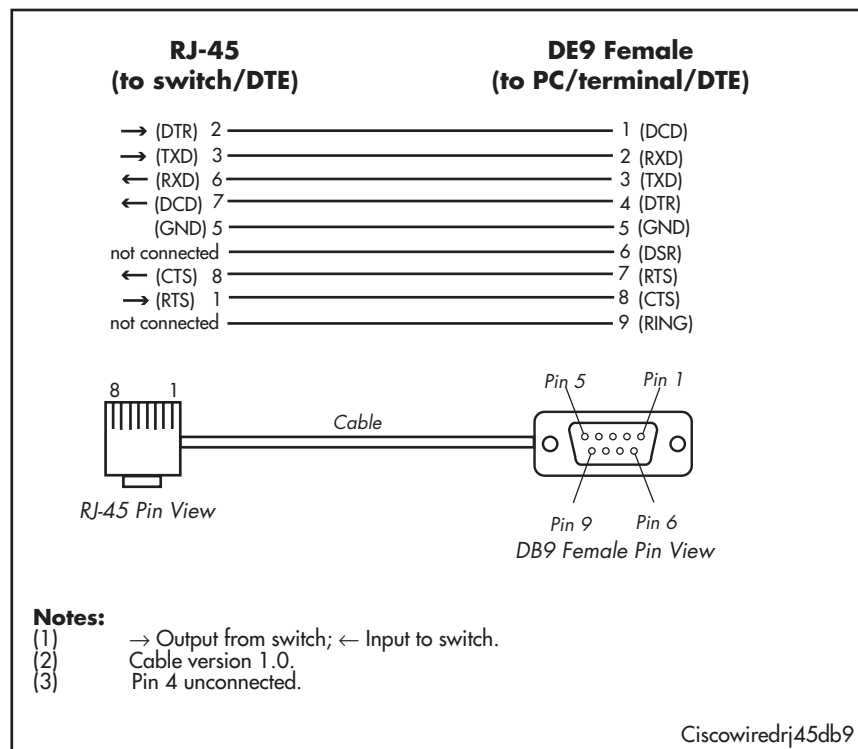
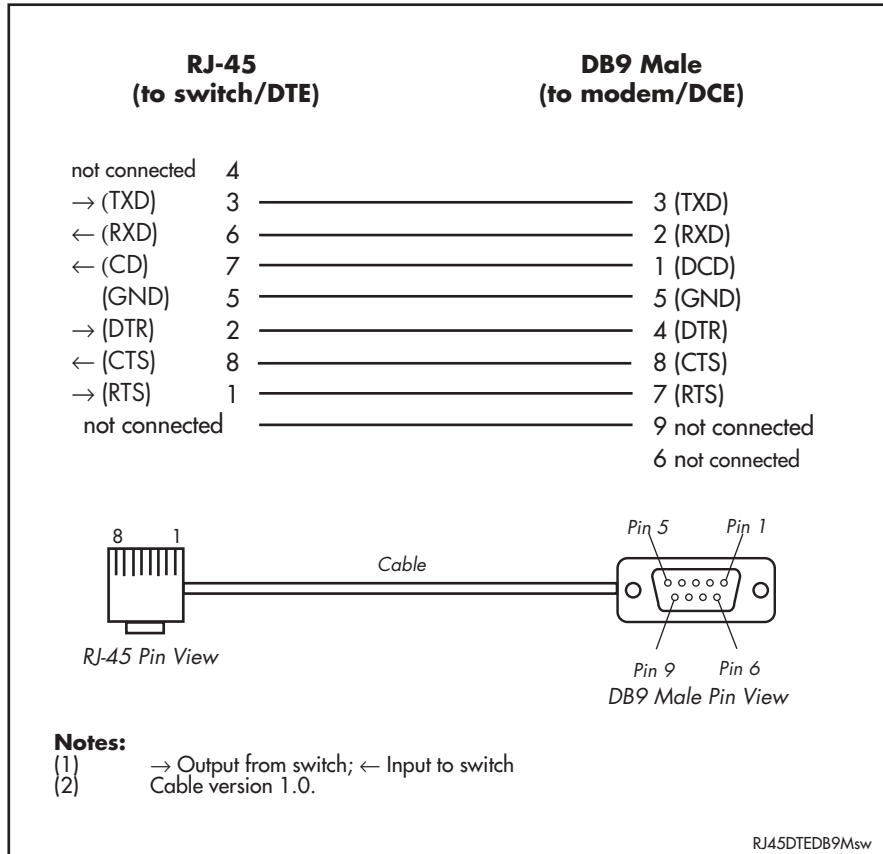

Figure 5: Pin wiring diagram for a DCE RS-232 Terminal Port (DB9 male connector) male to male modem cable.



More information on pin assignments for the RS-232 Terminal Port can be found in “RS-232 Terminal Port (ASYN0)” on page 15.

Cables for RJ-45 Ethernet LAN Interfaces

For 10BASE-T/100BASE-TX/1000BASE-T (10/100/1000BASE) connections, a twisted pair cable with four pairs and RJ-45 connectors must be used.

The cables used for network connections and testing of RJ-45 interfaces are listed in Table 5 on page 17.



Caution. Do not plug a phone jack into any RJ-45 port. Doing so could damage the switch. Use only twisted pair cables with RJ-45 connectors.

Table 5: Cables for RJ-45 LAN interfaces.

Purpose	Interface type	Cable type	Pairs	Pin assignment
Network	10/100/1000BASE	Straight through	Four	Table 6 on page 18
Test	10/100/1000BASE	Crossover or straight through	Four	Table 7 on page 19 or Table 6 on page 18

Pin assignments

For twisted pair cables each pair is identified by two different colours. For example, one wire might be red, and the other red with a white stripe. An RJ-45 connector must be fitted to both ends of the cable. Figure 6 on page 18 illustrates the pin layout for RJ-45 connectors.

Figure 6: RJ-45 Pin layout.

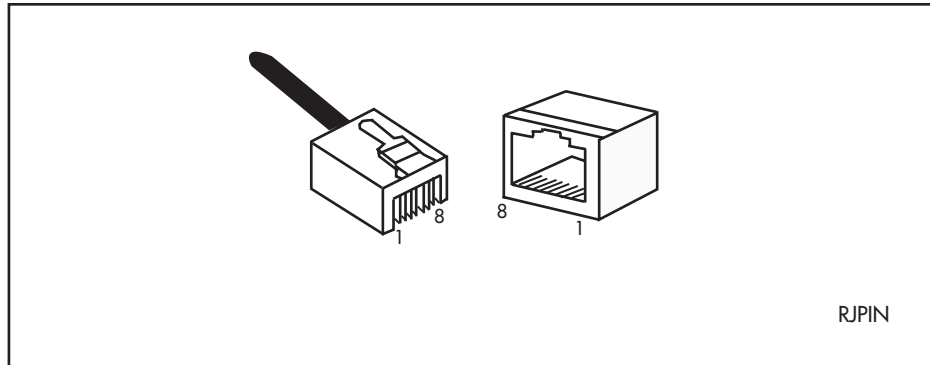

1000BASE straight through cable

For 1000BASE network connections, all four pairs are used and the cable is wired in a straight-through configuration. This cable can also be used, in conjunction with the software test facility, to test 1000BASE network ports. Table 6 on page 18 lists the pin assignments.

Table 6: Pin assignments, 10/100/1000BASE-T RJ-45 four pair straight-through cable.

End 1		End 2	
Pin	Pair	Pin	Pair
1	Pair 1+	1	Pair 1+
2	Pair 1-	2	Pair 1-
3	Pair 2+	3	Pair 2+
6	Pair 2-	6	Pair 2-
4	Pair 3+	4	Pair 3+
5	Pair 3-	5	Pair 3-
7	Pair 4+	7	Pair 4+
8	Pair 4-	8	Pair 4-

1000BASE crossover cable

For 1000BASE test cables, all four pairs are used and the cable is wired in either a crossover or straight-through configuration. Table 7 on page 19 lists the pin assignments for a crossover cable.

Table 7: Pin assignments, 10/100/1000BASE-T RJ-45 four pair crossover cable .

End 1		End 2	
Pin	Pair	Pin	Pair
1	Pair 1+	1	Pair 2+
2	Pair 1-	2	Pair 2-
3	Pair 2+	3	Pair 1+
6	Pair 2-	6	Pair 1-
4	Pair 3+	4	Pair 4+
5	Pair 3-	5	Pair 4-
7	Pair 4+	7	Pair 3+
8	Pair 4-	8	Pair 3-

Test Facility

This section introduces the Test Facility. The Test Facility is built into all AT-8900 Series software. For detailed information on operating the Test Facility, see the *Test Facility* chapter of the *AT-8900 Series Software Reference*.

Any interfaces being tested are dedicated to the Test Facility. The Test Facility can be thought of as a specialised interface module like PPP or Frame Relay.



Before using the test facility, disable any configurations (SET CONFIGURATION=NONE) and restart or reboot the switch.

Ethernet LAN Port Tests

A crossover cable is required to run an Ethernet LAN test. See “Useful Cables” on page 16 for details of how to make a suitable cable. To start the test, loop a four-pair crossover or straight-through cable between any two RJ-45 ports and enter:

```
ENABLE TEST INT=ALL
```

All interfaces connected by crossover cables are tested. Test results are displayed with the command:

```
SHOW TEST
```

which produces a display like that shown in Figure on page 20. A more detailed output (with frame counts) can be displayed with the command:

```
SHOW TEST COUNT
```

which is shown in Figure on page 21.

Figure 7: Example output from the SHOW TEST command .

Board	ID	Bay	Board Name	Rev	Serial number	
Base	201		AT-8948	P3-1	58364519	
Interface	State	Result	Type	Duration (minutes)	Details Data(%OK)	Control
port1	no test	-	-	-	-	-
port2	no test	-	-	-	-	-
port3	no test	-	-	-	-	-
port4	no test	-	-	-	-	-
port5	complete	good	ALL	1	good(100.0)	-
port6	no test	-	-	-	-	-
port7	testing	wait 2 minutes	ALL	< 1	good(100.0)	-
port8	no test	-	-	-	-	-
port9	no test	-	-	-	-	-
port10	no test	-	-	-	-	-
port11	no test	-	-	-	-	-
port12	no test	-	-	-	-	-
port13	no test	-	-	-	-	-
port14	no test	-	-	-	-	-
port15	no test	-	-	-	-	-
port16	no test	-	-	-	-	-
port17	no test	-	-	-	-	-
port18	no test	-	-	-	-	-
port19	no test	-	-	-	-	-
port20	no test	-	-	-	-	-
port21	no test	-	-	-	-	-
port22	no test	-	-	-	-	-
port23	no test	-	-	-	-	-
port24	no test	-	-	-	-	-
port25	no test	-	-	-	-	-
port26	no test	-	-	-	-	-
port27	no test	-	-	-	-	-
port28	no test	-	-	-	-	-
port29	no test	-	-	-	-	-
port30	no test	-	-	-	-	-
port31	no test	-	-	-	-	-
port32	no test	-	-	-	-	-
port33	no test	-	-	-	-	-
port34	no test	-	-	-	-	-
port35	no test	-	-	-	-	-
port36	no test	-	-	-	-	-
port37	no test	-	-	-	-	-
port38	no test	-	-	-	-	-
port39	no test	-	-	-	-	-
port40	no test	-	-	-	-	-
port41	no test	-	-	-	-	-
port42	no test	-	-	-	-	-
port43	no test	-	-	-	-	-
port44	no test	-	-	-	-	-
port45	no test	-	-	-	-	-
port46	no test	-	-	-	-	-

Figure 7: Example output from the SHOW TEST command (Continued).

port47	no test	-	-	-	-	-	-
port48	no test	-	-	-	-	-	-
port49	no test	-	-	-	-	-	-
port50	no test	-	-	-	-	-	-
port51	no test	-	-	-	-	-	-
port52	no test	-	-	-	-	-	-

asyn0	no test	-	-	-	-	-	-

Figure 8: Example output for the SHOW TEST COUNT command .

Board	ID	Bay	Board Name	Rev	Serial number		
Base	201		AT-8948	P3-1	58364519		

Interface	State	Type	Duration (minutes)	Tx	Frame Counters	RxBad	

port1	no test	-	-	-	-	-	
port2	no test	-	-	-	-	-	
port3	no test	-	-	-	-	-	
port4	no test	-	-	-	-	-	
port5	complete	ALL	1	000100567	000100566	000100566	000000000
port6	no test	-	-	-	-	-	
port7	testing	ALL	1	000107521	000107520	000107520	000000000
port8	no test	-	-	-	-	-	
port9	no test	-	-	-	-	-	
port10	no test	-	-	-	-	-	
port11	no test	-	-	-	-	-	
port12	no test	-	-	-	-	-	
port13	no test	-	-	-	-	-	
port14	no test	-	-	-	-	-	
port15	no test	-	-	-	-	-	
port16	no test	-	-	-	-	-	
port17	no test	-	-	-	-	-	
port18	no test	-	-	-	-	-	
port19	no test	-	-	-	-	-	
port20	no test	-	-	-	-	-	
port21	no test	-	-	-	-	-	
port22	no test	-	-	-	-	-	
port23	no test	-	-	-	-	-	
port24	no test	-	-	-	-	-	
port25	no test	-	-	-	-	-	
port26	no test	-	-	-	-	-	

Figure 8: Example output for the SHOW TEST COUNT command (Continued).

port27	no test	-	-	-	-	-	-
port28	no test	-	-	-	-	-	-
port29	no test	-	-	-	-	-	-
port30	no test	-	-	-	-	-	-
port31	no test	-	-	-	-	-	-
port32	no test	-	-	-	-	-	-
port33	no test	-	-	-	-	-	-
port34	no test	-	-	-	-	-	-
port35	no test	-	-	-	-	-	-
port36	no test	-	-	-	-	-	-
port37	no test	-	-	-	-	-	-
port38	no test	-	-	-	-	-	-
port39	no test	-	-	-	-	-	-
port40	no test	-	-	-	-	-	-
port41	no test	-	-	-	-	-	-
port42	no test	-	-	-	-	-	-
port43	no test	-	-	-	-	-	-
port44	no test	-	-	-	-	-	-
port45	no test	-	-	-	-	-	-
port46	no test	-	-	-	-	-	-
port47	no test	-	-	-	-	-	-
port48	no test	-	-	-	-	-	-
port49	no test	-	-	-	-	-	-
port50	no test	-	-	-	-	-	-
port51	no test	-	-	-	-	-	-
port52	no test	-	-	-	-	-	-
asyn0	no test	-	-	-	-	-	-

Other Interface Tests

Refer to the *Test Facility* of the *AT-8900 Series Software Reference* for information on testing other interfaces.



If a test fails, please contact your Authorised Allied Telesyn distributor or reseller.

Power Supply Units (PSUs)

At the rear of the AT-8900 Series switch chassis there are two power supply bays. AT-8900 Series switches allow for either one or two power supplies to be fitted (see Figure 9 on page 23). PSUs are hot-swappable and when two PSUs are fitted in a AT-8900 Series switch they will load share. PSUs contain fans needed to cool the AT-8900 Series switch. If only one power supply is fitted, a fan only module (FOM) must be fitted in the second power supply bay. Fitting two PSUs allows for power supply redundancy.

Figure 9: Rear panel of the AT-8948.

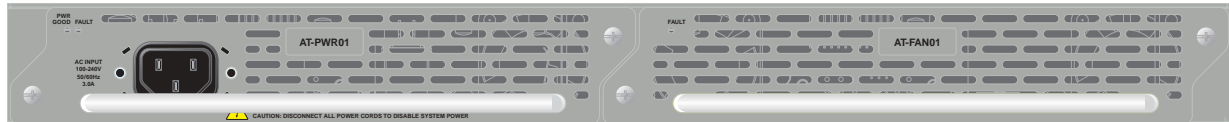

AC and DC power supplies are available. However, combinations of AC and DC power supplies are not supported. The AT-8900 Series switch will come with one PSU and one FOM as standard, with the second PSU being optional.

Each PSU and FOM will contain an EPROM allowing for command line interface identification of the modules. The EPROM will contain information including the type of module, serial number and revision of the PSU. This information will be available through the command line interface.



To order additional power supply units, contact your authorised Allied Telesyn distributor or reseller for more information, or visit <http://www.alliedtelesyn.co.nz/support/at8900>.

The PSUs and the FOM that can be fitted in AT-8900 Series switches are:

- AT-PWR01 (AC power supply unit)
- AT-PWR01 (DC power supply unit)
- AT-FAN01 (fan only module)

For PSU specifications see “Power Supply Unit” on page 4.

LEDs

- For each PSU bay there is one dual colour (green/red) LED situated on the front panel of the AT-8900 switch to indicate power supply status
- There are two LEDs on the rear panel of each PSU. An illuminated green LED indicates power good. An illuminated red LED indicates either fan failure or temperature exceeds the specified limit of 75 °C (167° F)

Controls

- Run/Standby switch DC version only
- Power switch recessed to prevent unintentional operation

Dimensions

- Height: 40.9 mm
- Width: 193 mm
- Depth: 130 mm

See the *AT-PWR01 Quick Install Guide* for information about Power Supply Unit and Fan Only Module installation procedures.

Port, Connector, and Cable Combinations

This section provides cabling guidelines for each switch model.

Table 8: Cable guidelines for AT-8900 Series switches.

Model	Port Type	Connector Type	Cable Type ¹	Maximum Cable Length
AT-8948	10BASE-T/100BASE-TX	RJ-45	CAT5 CAT5E	120 m Max
AT-8948	1000BASE-X	Varies with SFP	Refer to SFP user documentation	Refer to SFP user documentation

1. Refer to the IEEE 802.3 standards for further cable information.

Troubleshooting

This section provides information on how to detect and resolve problems with AT-8900 Series switches.

Other sources of useful troubleshooting information are:

- <http://www.alliedtelesyn.co.nz/support/at8900>
- The *AT-8900 Series Software Reference*.

LEDs and What They Mean

The following tables outline how LEDs on AT-8900 switches report faults and operational activities.

System LEDs

Table 9: System LEDs found on all AT-8900 Series Switches.

LED	State	Function
PSU 1	Green	PSU 1 is installed and supplying power to the switch, and voltage output is within specification.
	Red	PSU 1 is installed in the switch and a fan has failed, or the PSU has exceeded the recommend temperature threshold of 75° C (167° F). A FOM is installed in the switch and a fan has failed.
	Not lit	A FOM is installed and fan is good, or the bay is empty.
PSU 2	Green	PSU 2 is installed and supplying power to the switch, and voltage output is within specification.
	Red	PSU 2 is installed in the switch and a fan has failed, or the PSU has exceeded the recommend temperature threshold of 75° C (167° F). A FOM is installed in the switch and a fan has failed.
	Not lit	A FOM is installed and fan is good, or the bay is empty.
Fault	Red	The switch or management software is malfunctioning
	1 Flash	A switch fan has failed or is operating below the recommended speed
	6 Flashes	The switch's temperature has exceeded the recommended threshold
CF	Green	The compact flash memory is active. Do not eject the flash memory module

AT-8948 Port LEDs

Table 10: SFP Port LEDs on the AT-8948.

LED	State	Function
L/A (Link activity)	Green	A 1000 Mbps link is open. The link is operating in full duplex mode.
	Flashing green	1000 Mbps full duplex activity is occurring.
SFP (status)	Green	A SFP transceiver is installed.
	Flashing amber	A SFP transceiver is installed but there is a transmission fault.

Table 11: 10/100BASE-T Port LEDs on the AT-8948.

LED	State	Function
L/A (Link activity)	Green	A 100 Mbps link is open.
	Flashing green	100 Mbps activity is occurring.
	Amber	A 10 Mbps link is open.
	Flashing amber	10 Mbps activity is occurring..
D/C (Duplex/collision)	Green	The port is operating in full duplex mode.
	Amber	The port is operating in half duplex mode.
	Flashing amber	Collisions are occurring.

PSU and FOM LEDs

Table 12: LEDs on the AT-PWR01 and AT-FAN01.

LED	State	Function
Fault	Red	There is a fan failure or the temperature has exceeded the specified limit of 75° C (167° F).
PWR	Green	A PSU is installed in the switch and is receiving power. The FOM does not have this LED.

Check these first

1. Check the power cord connections.
2. Check that the power supply voltage is stable.
3. Check that the correct data cables are being used and that their connections are secure.
4. Make sure that other network devices are working properly.
5. Use the SHOW INSTALL command to check that the latest software release is loaded. See the *AT-8900 Series Software Reference* for more information about obtaining the latest software release.
6. If the switch is malfunctioning, reboot it by pressing the recessed Reset button or entering the command RESTART REBOOT. Alternatively, shut down and restart the switch using its power switch (AC models) or run/standby switch (DC models).

Some common problems and how to solve them

Link/Activity LED on any port is off

This can indicate:

- A loose data cable.
- The device at the other end of the connection is not working properly or is turned off.
- The data cable is not wired correctly.
- The network administrator has manually disabled the port through the software.
- The port's selected transmission mode does not match that of the attached device.

Perform the following steps in sequence:

1. Make sure the data cable connections are secure.
2. Make sure the device at the other end of the connection is switched on and working properly.
3. Check that the data cable is wired correctly.
4. If you can, log in and check the port status. See "To log In" on page 11 for more information on how to log in.
5. If the port is Enabled, make sure the transmission speed matches that of the connected device (auto-negotiating, full or half-duplex).



If the port is disabled, someone has used the software to manually disable it. You should find out why the port was disabled before enabling it.

Power LED is off

This can indicate:

- A loose power cord.
- A power supply failure.
- A FOM is installed in that bay.

Perform the following steps in sequence:

1. Check that the power cord connections are secure.
2. Check that all switches and circuit protection devices are in the ON position.
3. Ensure that the supply voltage is within the operational range (100 to 240 VAC 47 to 63 Hz for AC models, 36 to 72 VDC for DC models).

Fault LED is on

This can indicate:

- There is a problem with the switch.
- The switch or management software is malfunctioning.
- A hardware fault is preventing switch start-up.

Perform the following steps in sequence:

1. Check “LEDs and What They Mean” on page 24 for descriptions and explanations of LED flashing sequences.
2. Reset the switch by pressing the recessed RESET button on the front panel.
3. If you were attempting to download software or manage the switch via the RS-232 Terminal Port, check that connections between the Terminal Port and local terminal or PC are secure.

If you cannot access the switch’s software because of a faulty RS-232 Terminal Port connection, you can still manage the switch via Telnet or SNMP until the problem is fixed.

4. Download the latest software release. See the *AT-8900 Series Software Reference* for more information on how to obtain the latest software release.

Expansion Options

This section provides an overview of the expansion options for AT-8900 Series Switches. The following expansion options were available when this Reference was written. See your Authorised Allied Telesyn distributor or reseller, or visit <http://www.alliedtelesyn.co.nz/support/at8900> to see if any new options are available.

SFP transceivers

AT-8900 Series switches have 4 1000BASE-X small form-factor pluggable (SFP) uplink sockets on their front panel. SFP transceivers allow users to interchange port types to meet changing network requirements. SFP transceivers are hot swappable, fixed at full-duplex and fixed at a speed of 1Gbps. SFP transceivers can be purchased when a switch is purchased, or can be ordered separately as needed.



A range of SFP transceivers have been tested and approved for use with the AT-8900 Series Switches. Contact your authorised Allied Telesyn distributor or reseller for more information.

The following SFP transceivers have been approved for use with AT-8900 Series switches:

- AT-MG8T 100m Base-T SFP
- AT-MG8SX 300m SX SFP
- AT-MG8ZX 70km ZX SFP

For the latest list of approved SFP transceivers, visit <http://www.alliedtelesyn.co.nz/support/at8900>.

Installing and removing a SFP transceiver



Invisible laser radiation from disconnected fibres or connectors may be emitted. Do not look into SFP cables or transceivers.

To install a SFP transceiver:

- Slide the SFP transceiver into the SFP socket
- Press the SFP transceiver firmly into place

To remove a SFP transceiver:

- Pull the button at the bottom of the SFP transceiver in to delatch the SFP transceiver (See Figure 10 on page 29)
- Pull the SFP transceiver gently out of the SFP socket

Figure 10: SFP transceiver.

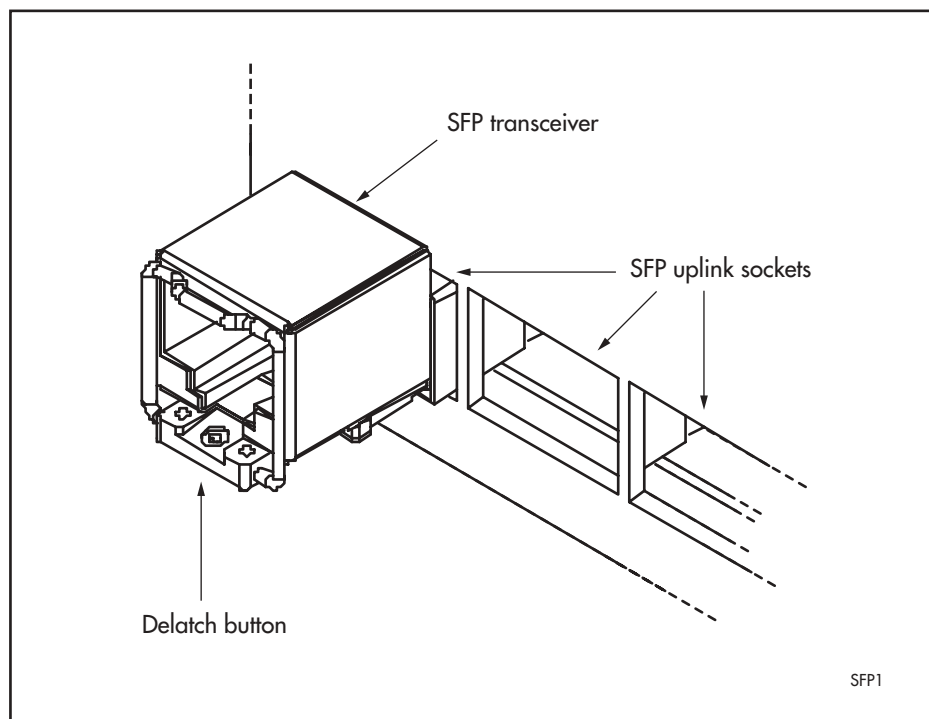

Compact Flash

AT-8900 Series switches have a compact flash socket on their front panel. Compact flash cards increase the flash memory available for file storage.

Compact flash files can be manipulated using the command line interface. Any type of data, including releases, patches, GUIs and configurations can be stored on compact flash cards. However, release, patch, and GUI files cannot be run directly from compact flash. These files must be loaded into either NVS or onboard flash.



Data contained on compact flash cards can be read with any compliant reader. Do not keep sensitive data, for example keys, on compact flash cards.

The following compact flash cards have been approved for use with the AT-8900 Series switch:

- AT-CF032A-*nnn* 32MB CompactFlash card
- AT-CF128A-*nnn* 128MB CompactFlash card

Where *n* is the number of cards in a package, less than 1000. A package containing one card is 001.

For the latest list of approved compact flash cards, visit <http://www.alliedtelesyn.co.nz/support/at8900>.



Compact flash cards used on the switch must support a hardware access time of no more than 100 nanoseconds. If a compact flash card does not meet the 100 nanosecond requirement it may not work as this is the maximum bus timing allowed.

Installing and removing a compact flash card

Compact flash cards can be inserted into the compact flash slot at any time. CLI messages are displayed when a card is inserted or removed. It takes approximately two seconds for an inserted card to be initialised. Messages notify the user when a card has been inserted:

```
Info (1106257): Compact flash card inserted.
```

and when the card is ready for use:

```
Info (1106268): Compact flash card initialisation successful.
```

A message notifies the user if the compact flash card is not compatible with the switch:

```
Info (3106300): Compact flash card initialisation
unsuccessful.
```

When compact flash is in use, the compact flash Activity LED on the rear panel of the switch is green.



Do not remove the compact flash card when it is being written to (that is, when the compact flash Activity LED is lit). Doing so will corrupt data on the file being written.

Testing a compact flash card

To display information about the basic state of a compact flash card, including card size, file count and serial number, insert the card and enter the command:

```
SHOW CFLASH
```

To display cluster ranges on a card, insert the card and enter:

```
SHOW CFLASH TEST
```

Figure 11 on page 31 shows a sample output.

Figure 11: Output from the SHOW CFLASH TEST command, when no test is running.

```
Clusters available for testing
  Ranges:
    [42645--61944]
  Number of free clusters = 19300
  Number of ranges       = 1
  Number of used clusters = 42645
```

To test a card, insert the card and enter:

```
ENABLE CFLASH TEST START=startnumber END=endnumber
```

where *startnumber* and *endnumber* are positive integers within a cluster range. The endnumber must be higher than the startnumber. Cluster ranges are displayed in the output of the SHOW CFLASH TEST command (Figure 11 on page 31).

The test software will read the file allocation table and display a list of free sectors. Sectors can be tested as single sectors or as a range. The test will consist of a write/read/verify cycle.

To stop the test, use the command:

```
DISABLE CFLASH TEST
```

To display the testing process while a test is in process, enter:

```
SHOW CFLASH TEST
```

Figure 12 on page 31 shows a sample output.

Figure 12: Output from the SHOW CFLASH TEST command, when a test is running.

```
Test Progress
  Starting cluster      = 700
  Ending cluster       = 1700
  Current cluster      = 1185

  Passed clusters number = 485
  Passed sectors number  = 1940

  Failed clusters number = 0
  Failed sectors number  = 0
  Used Clusters encountered = 0

  Duration..... 4417 ms
```

If used when testing is not active, the previous command displays blank cluster ranges on a compact flash card (Figure 11 on page 31).

Error messages are displayed when a file write fails. Failure could be due to the card being removed or an error in the card.

Dual In-line Memory Modules (DIMMs)

Synchronous DRAM for AT-8900 Series switches is provided by a single DIMM.

The following DIMM have been approved for use with the AT-8900 Series switch:

- AT-SD128A-00 128MB SDRAM (installed at factory)
- AT-SD256A-00 256MB SDRAM (upgrade)
- AT-SD512A-00 512MB SDRAM (upgrade)



Only Allied Telesyn supplied DIMMS have been tested and approved for use with AT-8900 Series switches. Using DIMM that has not been approved may cause unreliable operation and will invalidate the switch's warranty.

To check how much DIMM is installed, enter

```
SHOW SWITCH
```

For information on installing DIMM, see “Restricted Procedures” on page 32.

Restricted Procedures

This section contains procedures that should only be performed by authorised service personnel. Unauthorised use of procedures in this section may cause danger of injury from electric shock, damage to the switch, and invalidation of the product warranty.

If you would like to know more about the procedures outlined in this section, please contact your authorised Allied Telesyn distributor or reseller.

Lithium Battery

The lithium battery should only be changed by authorised service personnel.



There is a danger of explosion if the battery incorrectly replaced. Replace only with the same or equivalent type recommended by the manufacturer. Dispose of used batteries according to the manufacturer's instructions.

Installing DIMM

AT-8900 Series switches have one DIMM slot. The slot can be populated with either a 128 MByte DIMM, 256 MByte DIMM, or 512 MByte DIMM.



Only Allied Telesyn supplied DIMMS have been tested and approved for use with AT-8900 Series switches. Using DIMM that has not been approved may cause unreliable operation and will invalidate the switch's warranty.



For AT-8900 Series switches, DIMM should only be installed by authorised service personnel. Unauthorised opening of the switch's lid may cause danger of injury from electric shock, damage to the switch, and invalidation of the product warranty.

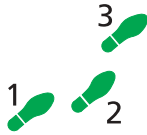

To install DIMM in an AT-8900 series switch:

1. Avoid injury by working in a safe environment.

The workspace should be free of hazards, and there should be sufficient room to lay out the switch, DIMM, and tools.

2. Disconnect the mains power cord.



Before removing the switch's lid the power cord(s) to the PSU(s) should be disconnected to reduce risk of electrical shock.

3. Remove all interface cables.

4. Remove the switch's lid.

The switch may need to be removed from any rack mounting system before its lid can be removed.

Using a posidrive screwdriver, remove the 7 screws that secure the switch's lid. There are 3 screws located in countersunk holes on each side of the lid, and 1 screw at the top.

5. Prepare the DIMMs.

In an antistatic environment, remove the DIMM from its packing material. Be sure to observe ESD precautions.



Do not attempt to install DIMM without observing correct antistatic procedures. Failure to do so may damage the DIMM and switch. If you are unsure what the correct procedures are, contact your authorised Allied Telesyn distributor or reseller.

6. To remove an existing DIMM.



Before removing the switch's lid the power cord(s) to the PSU(s) should be disconnected to reduce risk of electrical shock.

The DIMM is held in place by two retaining latches, one latch at each end of the DIMM slot. Release these latches and carefully pull the DIMM from the DIMM slot.

The DIMM slot's location is shown in Figure 13 on page 34.

Figure 13: AT-8900 Series DIMM slot.

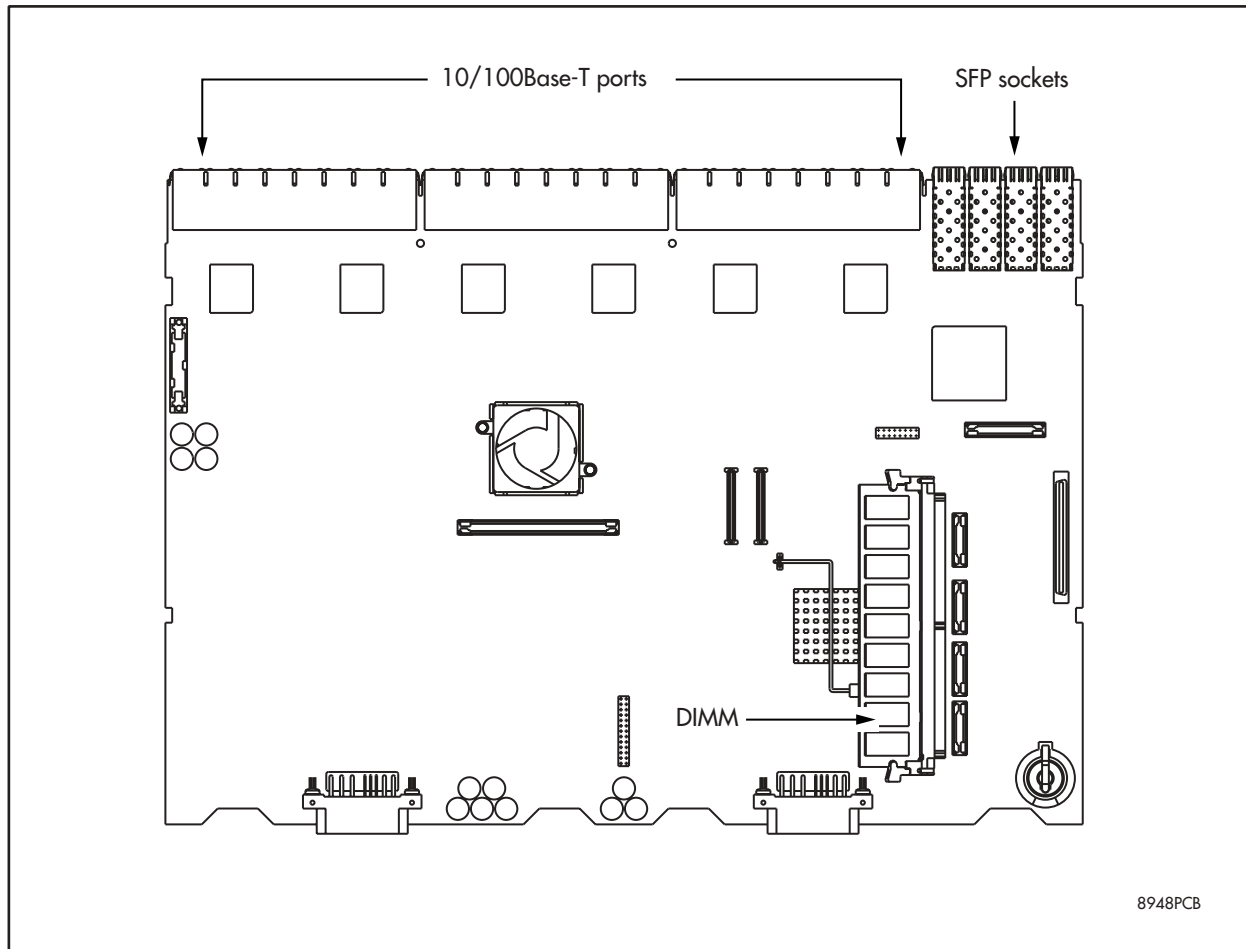

7. Align and insert the DIMM.

Holding a DIMM at an angle of about 30 degrees from horizontal, align the notches on its connector strips with the notches on an empty DIMM slot (see Figure 14 on page 35).

Insert the DIMM into the DIMM slot, sliding it along the two DIMM guides until the retaining latches automatically click into place. The latches should hold the DIMM firmly in place.

Figure 14: Installing DIMM.

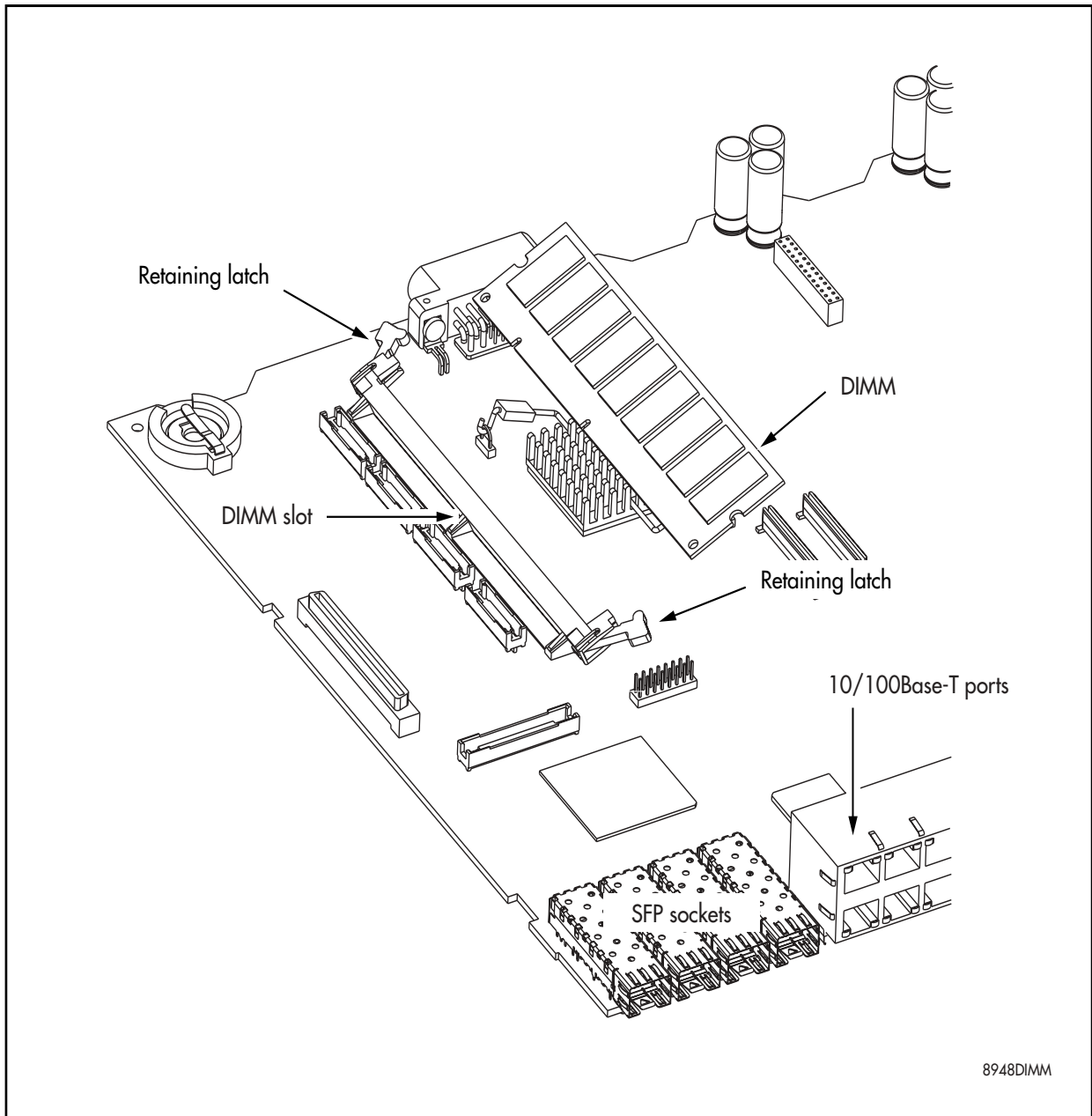

Testing DIMM

The switch is unlikely to boot unless the DIMM is correctly installed. If the switch does boot but you suspect the DIMM is malfunctioning, enter the command:

```
SHOW SYSTEM
```

to display the system information shown in Figure 15 on page 36. In the output's memory section there should be an entry showing the size of DRAM. If the DRAM size is less than the size of DIMM that has been installed, then the switch has not correctly detected the DIMM. The most likely cause is that the DIMM connector is not plugged into its slot correctly. Repeat the installation process, paying particular attention to the DIMM insertion step.

After repeating the installation, use the SHOW SYSTEM command again, and if the display is still not correct, contact your authorised Allied Telesyn distributor or reseller.



If you have any difficulty with the DIMM at any time, contact your authorised Allied Telesyn distributor or reseller and quote the serial numbers of both the base card on the switch and the DIMM. The switch's serial numbers and revision details can be read using the SHOW SYSTEM command. It's a good idea to record this information for later reference.

Figure 15: Example output from the SHOW SYSTEM command for an AT-9800 Series switch, showing DRAM.

```

Switch System Status                               Time 11:53:52 Date 08-Oct-2003.
Board      ID  Bay Board Name                          Rev      Serial number
-----
Base       201   AT-8948                          P3-1     58366529
-----
Memory -   DRAM : 65536 kB   FLASH : 15360 kB
-----
SysDescription
Allied Telesyn AT-8948 version 2.6.1-00 20-Aug-2003
SysContact

SysLocation

SysName

SysDistName

SysUpTime
124284 ( 00:20:42 )
Boot Image      : at8948bt.fbr size 618504 25-Aug-2003
Software Version: 2.6.1-00 20-Aug-2003
Release Version : 2.6.1-00 20-Aug-2003
Release built   : Oct 7 2003 at 10:19:06
Patch Installed : NONE
Territory       : usa
Help File       : help.hlp

Main PSU        : On           Main Fan         : On
RPS Monitor     : Off

Current Temperature : 29 C

Configuration
Boot configuration file: snoopy.cfg (exists)
Current configuration: snoopy.cfg

Security Mode    : Disabled

Warning (2048284): No patches found.

```

Diagnostics

The switch software includes a set of diagnostic programs. These programs perform basic level checks of all system components. They do not run in conjunction with the normal operating code, and require that the system be

totally dedicated to their use. A detailed knowledge of the way the switch hardware functions is necessary if diagnostics are to be used effectively.



The switch will not perform switching operations if diagnostics are running.



This section is not intended as a guide to the diagnostics software. Diagnostics are designed to be run by service personnel only. For more information, contact your Authorised Allied Telesyn distributor or reseller.

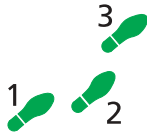

To enable diagnostics mode:

1. Connect a terminal to the RS-232 Terminal Port (ASYN0).

Using a terminal cable, connect a terminal to the RS-232 Port (ASYN0) on the switch. See “Useful Cables” on page 16 for more information on terminal cables.

Set the terminal communication parameters to the following:

- Baud rate: 9600
- Data bits: 8
- Parity: None
- Stop bits: 1
- Flow control: Hardware

2. Restart the switch.

Restart the switch, using an unbent paper clip, or something of similar dimensions, to operate the recessed reset button on the switch’s front panel, or by using the terminal to log in and enter the command:

```
RESTART REBOOT
```

See “To log In” on page 11 for more information on how to log in.

3. Enable diagnostics mode during start-up.

During the switch start-up process, at the prompt:

```
Force EPROM download (Y)?
```

press [Ctrl/D] on the terminal to enter diagnostics mode. A banner page will be displayed on the terminal (see Figure 16 on page 38). This can be used to check that the terminal is correctly connected.



Performing a Full flash Test or erasing flash will delete all configuration and release files. Make sure you know how to reload these files before erasing flash or performing a flash test.

Figure 16: AT-8900 Series diagnostics banner page.

```
* * * Diagnostic Mode * * *  
  
version: 16-Mar-1998  
  
Main Menu:  
0. Restart  
1. Full RAM test  
2. ROM checksum test  
5. Battery backed RAM test  
Enter selection ==>
```

To run a diagnostic program, enter the corresponding letter or number (or key). There are several sub-menus to cover all the available options. Table 13 on page 38 lists the control keys for diagnostic operations.

Table 13: Basic commands for running the diagnostics.

Key	Function
Q	Quits any running tests and displays the banner page.
S	Prints a summary of test results so far.

A reasonable understanding of the system's structure is needed to operate diagnostics and interpret the results.

To restore the switch to normal operation, use a pen or pencil to operate the recessed reset button on the front panel, or press "0" (zero) to restart.

Contacting Us

With locations covering all of the established markets in North America, Latin America and Europe, Allied Telesyn provides localized sales and technical support worldwide. To find our representative nearest you, visit Allied Telesyn on the web at: <http://www.alliedtelesyn.com>.